

Boxster

Owner's Manual

ATTENTION:
Read everything
in this manual
before operating
your Scooter



The Ultimate In Style & Performance[®]

Pride
Mobility Products Corp.

Exeter, PA
St. Catharines, ON

1-800-800-8586

www.pridemobility.com

SAFETY GUIDELINES

Please read and follow all instructions in this owner's manual before attempting to operate your Scooter for the first time. If there is anything in this manual you do not understand, or if you require additional assistance for set-up, contact your local authorized Pride provider.

Using your Pride product safely depends upon your diligence in following the warnings, cautions, and instructions in this owner's manual. Using your Pride product safely also depends upon your own good judgement and/or common sense, as well as that of your provider, caregiver, and/or healthcare professional. Pride is not responsible for injuries and/or damage resulting from any person's failure to follow the warnings, cautions, and instructions in this owner's manual. Pride is not responsible for injuries and/or damage resulting from any person's failure to exercise good judgement and/or common sense.

The symbols below are used throughout this owner's manual to identify warnings and cautions. It is very important for you to read and understand them completely.



WARNING! Failure to heed the warnings in this owner's manual may result in personal injury.



CAUTION! Failure to heed the cautions in this owner's manual may result in damage to your Scooter.

CONTENTS

I. INTRODUCTION	4
II. SAFETY	6
III. EMI/RFI	9
IV. SPECIFICATIONS	12
V. DESCRIPTION	14
VI. BATTERIES AND CHARGING	19
VII. OPERATION	23
VIII.COMFORT ADJUSTMENTS	25
IX. DISASSEMBLY AND ASSEMBLY	27
X. BASIC TROUBLESHOOTING	29
XI. CARE AND MAINTENANCE	30
XII. OPTIONAL ACCESSORIES	31
XIII.WARRANTY	32



Boxster

I. INTRODUCTION

Welcome to Pride Mobility Products Corporation (Pride). Congratulations on the purchase of your new Pride Scooter. Your scooter design combines the most advanced state-of-the-art components with modern, attractive styling. We are certain that the design features and trouble-free operation will add convenience to your daily living and ensure complete satisfaction.

At Pride, your safety is important to us. **Please read and follow all of the instructions in this manual before you attempt to operate your scooter for the first time.** These instructions were produced for your benefit. Your understanding of these instructions is essential for the safe operation of your new Pride Scooter.

Pride is not liable for damage to property or personal injury arising out of the unsafe use of a Pride Scooter. Pride is also not liable for any property damage or personal injury arising out of the failure of any person and/or user to follow the instructions and recommendations set forth in this manual or any other instructions or recommendations contained in other scooter related literature issued by Pride or contained on the Pride Scooter itself.

This owner's manual is compiled from the latest specifications and product information available at the time of publication. We reserve the right to make changes as they become necessary. Any changes to our products may cause slight variations between the illustrations and explanations in this manual and the product you have purchased.

If you experience any problems with your scooter that you are not able to solve, or if you do not feel capable of safely following any of the instructions and/or recommendations contained in this manual, please contact your authorized Pride Provider for assistance.

Once you understand how to operate and take care of your scooter, we are certain that it will give you years of trouble-free service and enjoyment.

Information Exchange

We want to hear your questions, comments, and suggestions regarding this manual. We would also like to hear about the safety and reliability of your new Pride Scooter, and the service you received from your authorized Pride Provider.

Please notify us of any change of address so we can keep you apprised of important information regarding safety, new products, and new options that can increase your ability to use and enjoy your Pride Scooter. Please feel free to write us at the address below:

Pride Mobility Products Corporation
Attn: Customer Care Department
182 Susquehanna Avenue
Exeter, PA 18643-2694

customer@pridemobility.com
1-800-424-8205

I. INTRODUCTION

Pride Owners Club

As a Pride product owner, you are invited to register your product's warranty and enroll in the Pride Owners Club. You may do so by filling out and returning your enclosed registration card or by visiting Pride's web site at www.pridemobility.com. As a registered member, each time you visit our site you will have access to the most interactive and honest educational venue available today for people with mobility needs, their families, and friends.

From our home page, click on the button that reads "Owners Club" to enter a page dedicated to current and potential Pride product owners. You will gain access to interviews, stories, recreation ideas, daily living tips, product and funding information, and interactive message boards. Message boards invite you to speak with other Pride customers as well as Pride representatives who are available to assist you with any questions or concerns you may have.

My Authorized Pride Provider Is:

Name: _____

Address: _____

Phone Number: _____

Quick Reference Information:

Scooter Model: _____

Serial Number: _____

Purchase Date: _____

NOTE: If you ever lose or misplace your product registration card or this owner's manual, contact us and we will be glad to send you a new one immediately.

II. SAFETY

As you begin to use your Boxster during your daily activities, you will encounter situations that, at first, may require some practice to negotiate on your Boxster PMV. Simply take your time as you operate your Boxster and you will soon be in full and confident control as you maneuver through doorways, on and off of elevators, up and down ramps, and over moderate terrain.

DOORS

- Determine if the door opens toward or away from you.
- Use your hand to turn the knob or push the handle or push-bar.
- Drive your Boxster gently and slowly forward to push the door open; or drive your Boxster gently and slowly backwards to pull the door open.

ELEVATORS

Modern elevators have a door-edge safety mechanism that, when pushed, reopens the elevator door(s).

- If you are in the doorway of an elevator when the door(s) begin to close, push on the rubber door edge or allow the rubber door edge to contact the PMV and the door will reopen.
- Use care that pocketbooks, packages, or Boxster accessories do not become caught in the elevator doors.

RAMPS AND OTHER INCLINES

More and more buildings have ramps with specified degrees of inclination. These ramps are designed for easy and safe PMV access. Some ramps may have turning switchbacks that require good cornering skills on your Boxster.

- Take wide swings with your Boxster's front wheels around any tight corners. If you do that, the Boxster's rear wheels will follow a wide arc. Do not cut the corner short, and do not bump into or get hung up on any railing corners.
- When driving down a ramp, keep the Boxster's speed adjustment dial (see V. "Description") set to the tortoise (slowest speed setting) to ensure a safely controlled descent.
- Never drive your Boxster across the side of a hill or diagonally up or down a hill, and do not stop, if possible, while driving up or down an incline.
- Avoid sudden stops and starts.

Other inclines may be natural or, if man-made, not designed specifically for PMVs. Figure 1 illustrates your Boxster's stability and its ability to climb grades under various weight loads and under controlled testing conditions.

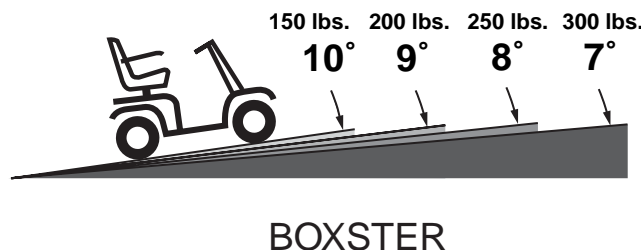

Figure 1. Maximum Recommended Incline Angle

II. SAFETY

These tests were conducted with the Boxster's seat in the highest position and adjusted backward on the seat base to its farthest rearward position. Use this information as a guideline. Your Boxster's ability to travel up inclines is affected by your weight, your PMV's speed, your angle of approach to the incline, and your PMV setup.

- When you approach an incline, it is best to lean forward. See figures 2 and 3. This shifts the center of gravity of you and your Boxster toward the front of the PMV for improved stability.



WARNING! Do not exceed the incline guidelines or any other specifications presented in this manual.



Figure 2. Normal Driving Position

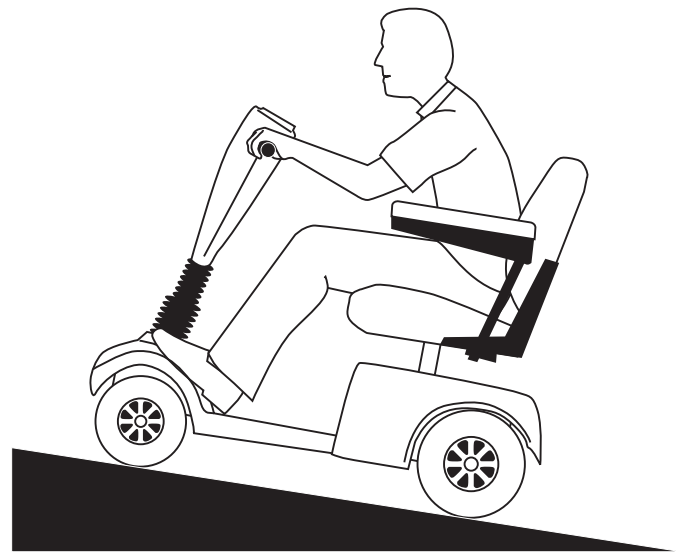

Figure 3. Increased Stability Driving Position

DRIVING SURFACES

Your Boxster was designed to provide optimum stability under normal driving conditions; dry, level surfaces composed of concrete or asphalt. However, Pride recognizes the fact that there will be times when you will operate your Boxster on surfaces other than concrete or asphalt. So we have also designed your Boxster to perform admirably on packed soil, grass, and gravel.

- Feel free to use your Boxster safely on lawns and in park areas.
- Avoid tall grass that can entangle the running gear.
- Packed soil and gravel, such as driveways or roads, will present no problem for your Boxster.
- Avoid loosely packed gravel and sand.
- If you feel unsure about a driving surface, avoid that surface.

II. SAFETY

SAFETY PRECAUTIONS

- Do not operate your new Boxster for the first time without completely reading and understanding this owner's manual.
- Do not carry passengers on your Boxster.
- If your Boxster is equipped with a reclining seat, DO NOT operate the vehicle with the seat in the reclined position.
- Do not leave the key in the key switch when your Boxster is unattended.
- Make certain that the seat is locked into place and that the key is removed from the key switch before getting on or off of your Boxster. Make certain that the seat is in a locked position when you are operating your Boxster.
- Reduce your Boxster's speed when you are operating it on uneven terrain and soft surfaces.
- Reduce your Boxster's speed when you are driving it around a corner.
- Never drive your Boxster across the side of a hill or diagonally up or down a hill, and do not stop, if possible, while driving up or down an incline.
- Proceed with extreme caution as you approach the downgrade of a ramp or other incline and when driving near a raised surface or unprotected ledges and drop-offs (curbs, porches, stairs, etc.).
- Never remove your Boxster's anti-tip wheels or modify the Boxster in any way that is not authorized by Pride.
- Use extreme caution when operating your Boxster on busy streets and in parking lots or shopping malls and never ride your Boxster where you cannot safely and legally walk. Consult local municipal or state agencies with regard to operating your Boxster on public roadways.
- Do not operate your Boxster while you are under the influence of alcohol.
- Check with your physician if you are taking any medications that may affect your ability to operate your Boxster safely.
- Keep your hands on the tiller and your feet on the floorboard when you are operating your Boxster.
- Make certain that the tires are properly inflated (30 psi).
- Never use your Boxster PMV as a seat in a moving vehicle.
- Make certain that the Boxster's batteries are properly secured when you are transporting your PMV in another vehicle.
- Disconnect your Boxster's batteries if you will not be using the PMV for more than 48 hours.
- Battery posts, terminals and related accessories contain lead and lead compounds. Wash hands after handling.

WARNING! Do not expose the electronics to any type of moisture at any time (rain, snow, mist, or washing the PMV). Such exposure can damage the electronics. Never attempt to ride a PMV that has been exposed to moisture until it has dried thoroughly.



Do not operate or store the PMV where it may be exposed to inclement weather conditions such as rain, snow, mist, and below-freezing temperatures (such as storage on an outside car/van lift). Attempting to operate the PMV in such conditions can damage the electronics and potentially result in loss of control.

Do not operate a PMV in icy or slippery conditions or on salted surfaces (i.e., walks or roads). Such use may result in an accident, personal injury, or adversely affect the performance and/or safety of your PMV.

Always protect batteries from freezing temperatures and never charge a frozen battery. This will damage the battery and may cause personal injury. Attempting to charge a battery in freezing conditions does not prevent a battery from freezing.

III. EMI/RFI

EMI/RFI WARNINGS

Laboratory tests performed by the Food and Drug Administration (FDA) have shown that radio waves can cause unintended motion of electric PMVs. Radio waves are a form of electromagnetic energy (EM). When electromagnetic energy adversely affects the operation of an electrical device, that adverse effect is called *Electromagnetic Interference (EMI) or Radio Frequency Interference (RFI)*.

EMI/RFI FREQUENTLY ASKED QUESTIONS (FAQS)

The following FAQs summarize what you should know about EMI/RFI. Use this information to minimize the risk that EMI/RFI will adversely affect your Boxster.

Where do radio waves come from?

Radio waves are emitted from the antennas of cellular phones, mobile two-way radios (such as walkie-talkies and CBs), radio stations, TV stations, amateur radio (HAM) transmitters, wireless computer links, microwave sources, and paging transmitters. Radio waves are a form of EM. Because EM is more intense closer to transmitting antennas (sources of emission), the EM fields from two-way radios are of special concern to electric PMV users.

If EMI/RFI affects my Boxster, what kind of motion should I expect?

This is difficult to predict. The answer would depend on a number of factors:

- The strength of the radio waves.
- The construction of your particular Boxster.
- The location of your Boxster (whether it is on level ground or on an incline).
- Whether or not your Boxster is in motion.

The motion of any electric PMV affected by EMI/RFI can be erratic. The PMV may come to a sudden stop or move in an uncontrolled manner. Also, it is possible for EMI/RFI to release the brakes of an electric PMV. Some intense EMI/RFI can even damage the control system components of an electric PMV.

Is there any way to know for certain whether or not radio waves are the cause of any unintended motion of my Boxster?

Unfortunately, EMI/RFI may be difficult to recognize, since the signals from radio sources are invisible and may be intermittent. However, the FDA recommends that you report all incidents of unintended motion or unintended brake release of your electric PMV to the PMV's manufacturer and, if possible, determine whether or not there was a radio wave source nearby at the time of the incident.

One precaution you can take against inadvertent motion of your Boxster is to make certain that you or someone else is not the cause of the unintended motion.

- Turn off your Boxster by removing the key from the key switch when you are getting on or off of your Boxster.
- Never leave the key in the key switch of an unattended Boxster.
- By following these steps, you greatly reduce the risk of you or anyone else inadvertently bumping the throttle control levers and causing the Boxster to move unintentionally.

III. EMI/RFI

Has anyone been injured by the erratic, unintended motion of an electric PMV?

The FDA has reports of injuries that resulted from uncontrolled motion of electric PMVs, but it is not clear just how many of those injuries were actually caused by EMI/RFI.

Are all PMVs susceptible to EMI/RFI?

Each make and model of electric PMV differs in its ability to resist EMI/RFI. That is, each PMV has a particular level of resistance to EMI/RFI. This resistance is measured in volts per meter (V/m). A higher resistance level offers greater protection against EMI/RFI. In other words, an electric PMV with a high resistance level is less likely to be affected by a strong radio source than is an electric PMV with a low resistance level.

What is the FDA doing about the problem?

The FDA has written to electric PMVs manufacturers and requested that those manufacturers test their new PMV models to be certain that they provide a reasonable degree of resistance against EMI/RFI. The FDA has stated that all newly manufactured models of electric PMVs should have a resistance level of at least 20 V/m. This resistance level provides a reasonable degree of protection against the common sources of EMI/RFI.

The FDA has also requested or recommended that:

- Electric PMV manufacturers clearly label new products with that product's resistance level or state that the resistance level is not known.
- The labeling or informational material supplied with new electric PMVs must explain what the resistance level means and warn users about the possibility of EMI/RFI and how to avoid it.
- Electric PMV manufacturers undertake an educational program to inform electrical PMV users and their caregivers about the problems associated with EMI/RFI and about the actions they can take to minimize the risk of EMI/RFI.
- While there is no exact way to tell if your PMV is totally safe, an immunity level of 20 V/m (May 1994) is generally achievable and useful. Adding accessories and components or modifying the unit may change the susceptibility to EMI/RFI.

What can I do to find out if my Boxster is likely to be affected by EMI/RFI?

If you have had your Boxster for some time and have not experienced any unintended motion, it is not likely that you will have a problem in the future. However, it is always possible that EMI problems could arise if you are close to a source of radio waves. Therefore, it is very important for you to be alert to this possibility. The Boxster PMV meets or exceeds a resistance level of at least 20 V/m.

What can I do to reduce the risk of my Boxster being affected by EMI/RFI?

Here are some precautions you can take:

- Do not turn on or use hand-held personal communications devices, such as citizen's band (CB) radios and cellular phones, while your Boxster is turned on.
- Be aware of nearby radio wave transmitters, such as radio or TV stations and hand-held or mobile two-way radios. Try not to operate your Boxster too close to those transmitters. For example, if you are on an electric PMV with a resistance level of at least 20 V/m, you should remain at least three feet from a hand-held two-way radio and at least ten feet from a mobile two-way radio.

III. EMI/RFI

- Be aware that adding accessories and/or components, or modifying your Boxster in any way, may change its EMI/RFI resistance level and may make it more susceptible to interference from radio wave sources.

What should I do if my Boxster moves unexpectedly?

If unintended motion or unintended brake release occurs, turn off your Boxster (by removing the key) as soon as it is safe to do so.

If my Boxster moves unintentionally, where should I report the incident?

Call our headquarters at 1-800-800-8586 to report the incident.

IV. SPECIFICATIONS

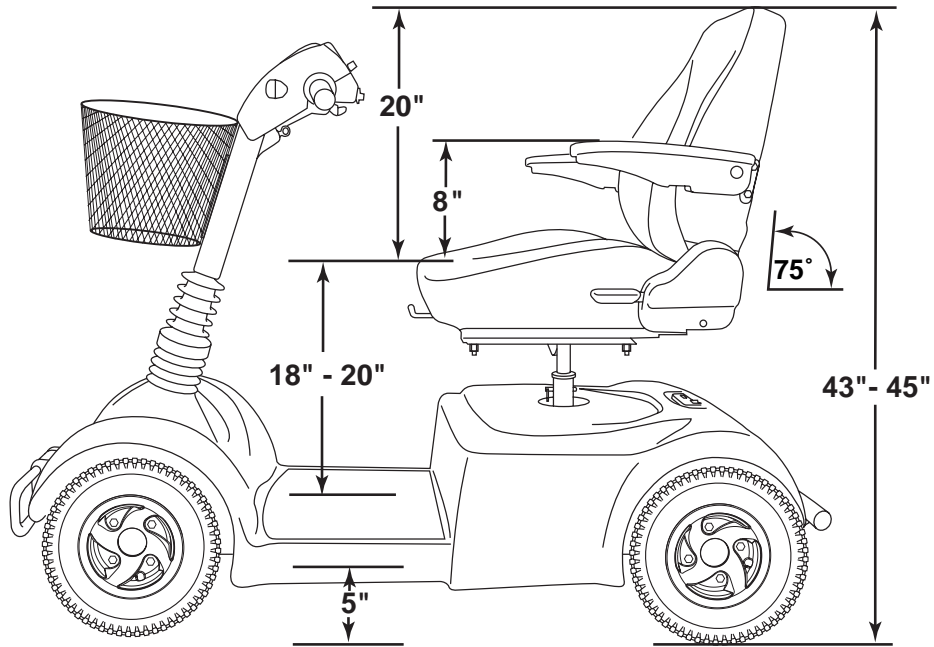
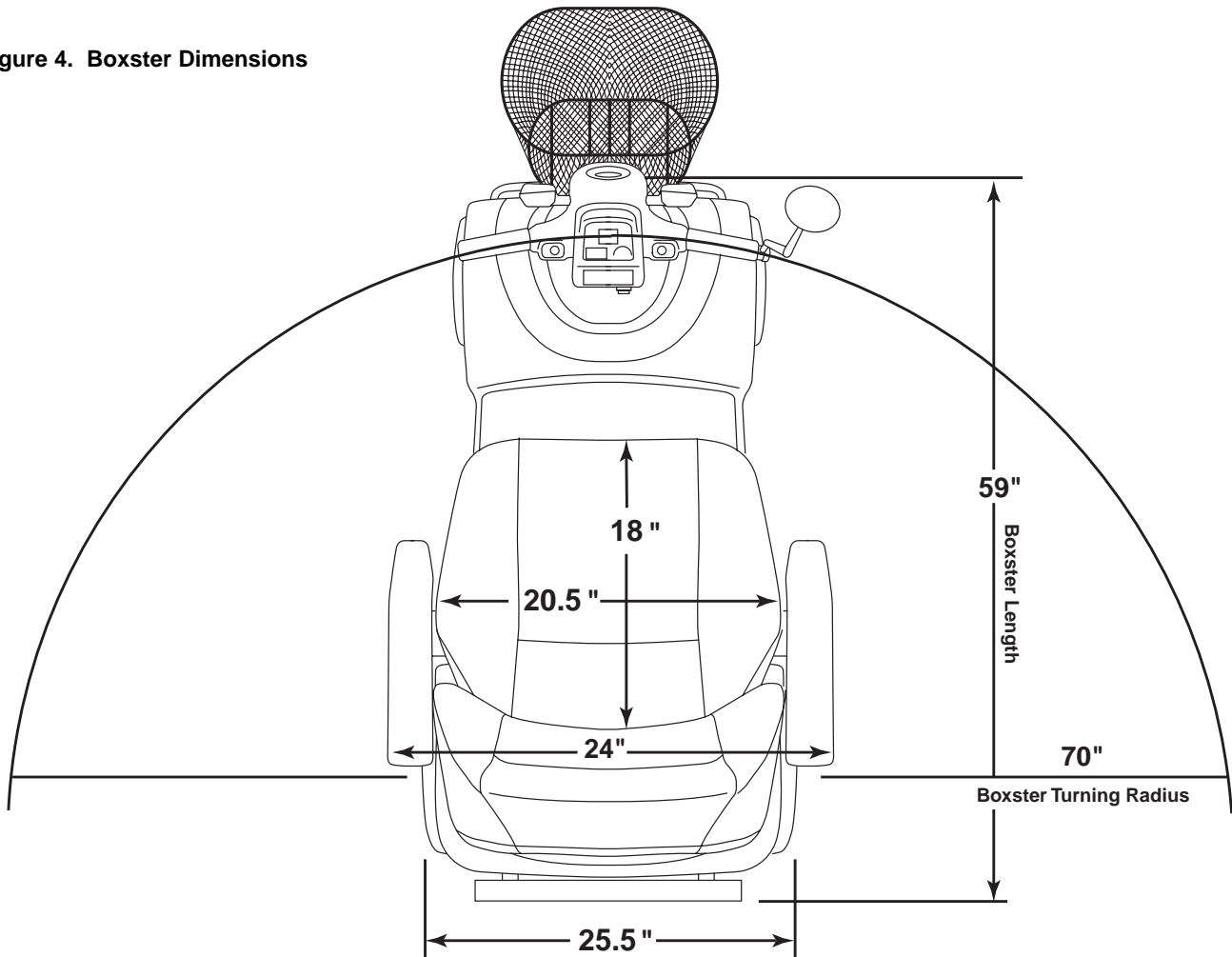

Figure 4. Boxster Dimensions



IV. SPECIFICATIONS

Specifications	
Model Numbers	PMV520CRED; PMV520VBLU; PMV520HGRN; PMV520OBLK
Length	59 in. (56 in. without front & rear bumpers)
Width	25.5 in.
Tires	Type: Pneumatic: 4 in. x 13 in.
Weight Capacity	300 lbs. maximum
Battery Type (Batteries not included)	Two 12V, 32 AH, U-1 type, SLA (Sealed Lead Acid) two 12V, 40AH SLA; two 12V, 45AH NF-22, SLA; or two 12V, 55AH NF-22, SLA
Horsepower	2.0 hp (peak)
Charger	Onboard 3-amp Charger
Speed (Maximum)	Variable up to 8.0 mph
Maximum Grade	See figures 1 through 4
Range	20-25 miles w/32 AH batteries; 25-30 miles w/40 AH batteries 30-35-miles w/NF-22-45AH batteries; 35-40-miles w/NF-22-55AH batteries
Turning Radius	70 in.
Body Colors	Painted: Candy Apple Red, Viper Blue, or Hunter Green, Onyx Black
Seating	Style: High back w/reclining mechanism and user-adjustable sliding seat mechanism Dimensions: 20.5 in. width (usable) 20 in. height (usable) X 18 in. depth (usable) Seat Cover Material: Gray vinyl Armrests: Black molded rubber User Adjustable seat height from ground: 24.5 in.– 26.5 in. User Adjustable seat height from scooter deck: 18 in. – 20 in.
Included Features	Full dynamic front/rear suspension; triple-sized battery compartment (for use of U-1, 40 AH, or NF-22); standard front and rear bumpers; high-back seat with user adjustable recline angle, armrests, and sliding mechanism; external freewheel release lever; external circuit breaker; easily accessible battery charger A/C plug receptacle; recessed tiller headlight; front basket; onboard accessory bracket; microprocessor based motor controller; energy saving auto shutoff feature
Brakes	Electronic regenerative braking and electromechanical disc brake
Rear Wheel Drive	Transaxle, 24V
Wheels	Black
Tiller Type	Adjustable
Free Wheel Mechanism	Freewheel release lever located upon upper-right rear portion of rear shroud
Weight of Scooter	Total Weight of Boxster (with two 12V 32AH batteries = 226 lbs.) Total Weight of Boxster (with two 12V 40AH batteries = 241 lbs.) Total Weight of Boxster (with two 12V 45AH batteries = 252 lbs.) Total Weight of Boxster (with two 12V 55AH batteries = 258 lbs.) Total Weight of Boxster (without batteries = 176 lbs.) Component breakdown: Front section without batteries or basket: 57.0 lbs. Rear section without rear shroud: 66.0 lbs. Rear plastic shroud: 5.0 lbs. Seat: 46.5 lbs. Basket: 1.5 lbs. Batteries: (Note: two batteries are required per scooter) 12V, 32 AH - 25.0 lbs. (each) 12V, 40 AH - 32.5 lbs. (each) 12V, 45 AH - 38.0 lbs. (each) 12V, 55 AH - 41.0 lbs. (each)
Front-to-Rear Lockup	Lock pin and dual camlock lever system
Ground Clearance	5.0 in.
Optional Accessories	Rear basket; safety flag

V. DESCRIPTION

Your Boxster is a motorized electric PMV designed to enhance your personal mobility. Your Boxster is an indoor/outdoor PMV designed to travel primarily on smooth surfaces such as sidewalks, roads, parking lots, floors, and driveways. For easy transportation or storage, you can disassemble your Boxster into seven components. See figure 5.



Figure 5. Seven Boxster Components

CONTROL CONSOLE ASSEMBLY

The control console assembly houses all the controls you need to drive your Boxster including the key switch, the speed adjustment dial, the throttle control lever, the battery condition meter, the horn button, turn signal buttons, the 4 to 8 switch, and the light switch. See figure 6.

Do not expose the control console assembly to moisture. In the event that the console does become exposed to moisture, do not attempt to operate your Boxster until the control console assembly has thoroughly dried.

KEY SWITCH

- Insert the key into the key switch and turn it clockwise to power up (turn on) your Boxster.
- Turn the key counterclockwise to power down (turn off) your Boxster.



WARNING! If the key is removed from the key switch while your Boxster is in motion, the electronic brakes will engage and your Boxster will come to an abrupt stop!

V. DESCRIPTION

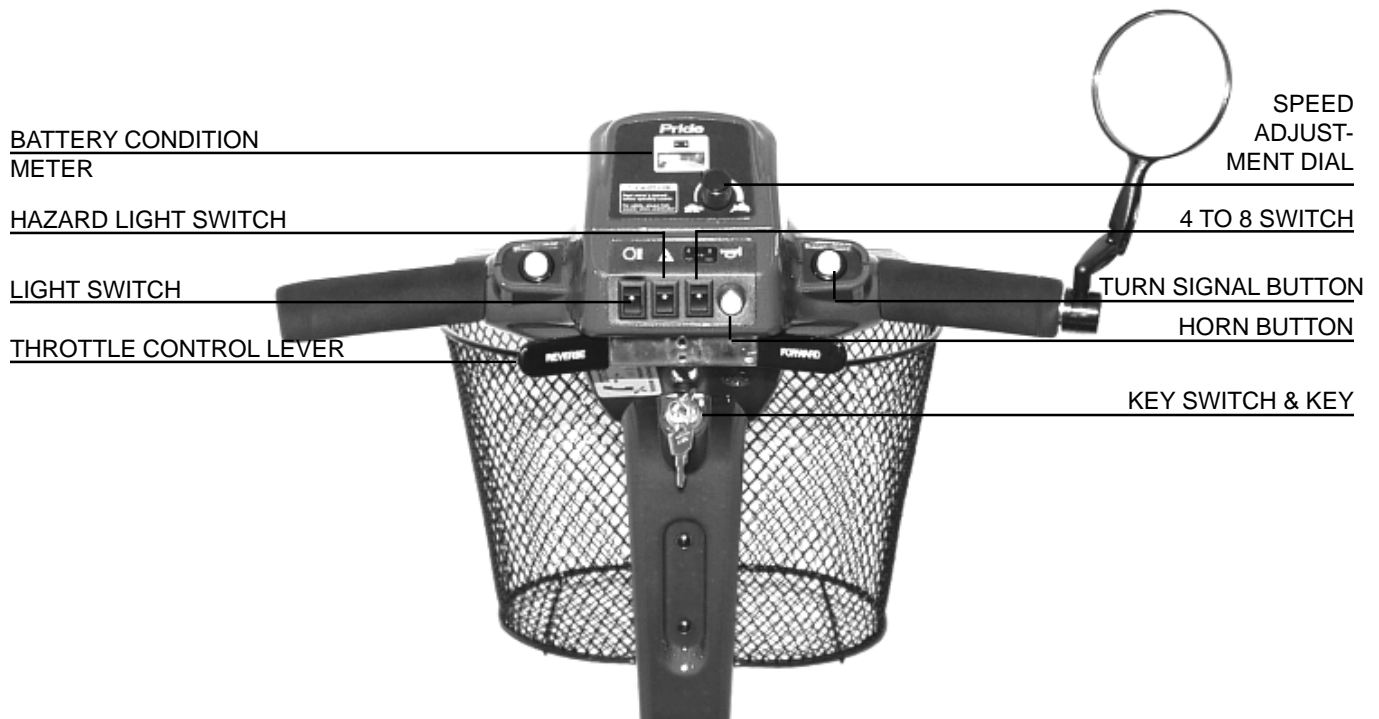

Figure 6. Control Console Assembly

SPEED ADJUSTMENT DIAL

- This dial allows you to pre-select and limit your Boxster's top speed.
- The image of the tortoise represents the slowest speed setting.
- The image of the hare represents the fastest speed setting.

4MPH - 8MPH SWITCH

This switch limits the Boxster's top speed to either 4 or 8 mph.

THROTTLE CONTROL LEVER

- This lever allows you to control the forward speed and the reverse speed of your Boxster up to the maximum speed preset at the speed adjustment dial.
- Place your right hand on the right hand-grip and your left hand on the left hand-grip.
- Use your right thumb to push the right side of the lever to disengage your Boxster's brake and move forward.
- Release the lever and allow your Boxster to come to a complete stop before pushing the other side of the lever to move in reverse.
- When the throttle is completely released, it automatically returns to the center "stop" position and engages your Boxster's brake.

V. DESCRIPTION

BATTERY CONDITION METER

Whenever you have the key fully inserted, this meter gives an approximate reading of your Boxster's battery voltage.

HORN BUTTON

- The key must be fully inserted into the key switch for the horn to be operational.
- This button activates a warning horn.
- Do not hesitate to use the warning horn when you feel its use will prevent accident or injury.

LIGHT SWITCH

- This switch controls your Boxster's headlight system.
- Press this switch once to turn on the light.
- Press it again to turn off the light.

HAZARD LIGHT SWITCH

The hazard light switch operates the 4-way flashers

- Press this switch once to turn on the lights.
- Press it again to turn off the lights.

TURN SIGNAL BUTTONS

These buttons control the turn signals on the tiller and rear shroud of your Boxster.

- Press the turn signal button once to active the lights.
- The turn signal automatically shuts off within a few seconds after the button has been pushed.

V. DESCRIPTION

REAR SECTION

The on-board battery charger, the charger power cord receptacle, the anti-tip wheels, the batteries (not shown), the electronic controller module, the main circuit breaker reset button, the manual freewheel lever, and the motor/transaxle assembly are located on the rear section of your Boxster. See figure 7. See IX. “Disassembly and Assembly” for instructions on removing the rear shroud.

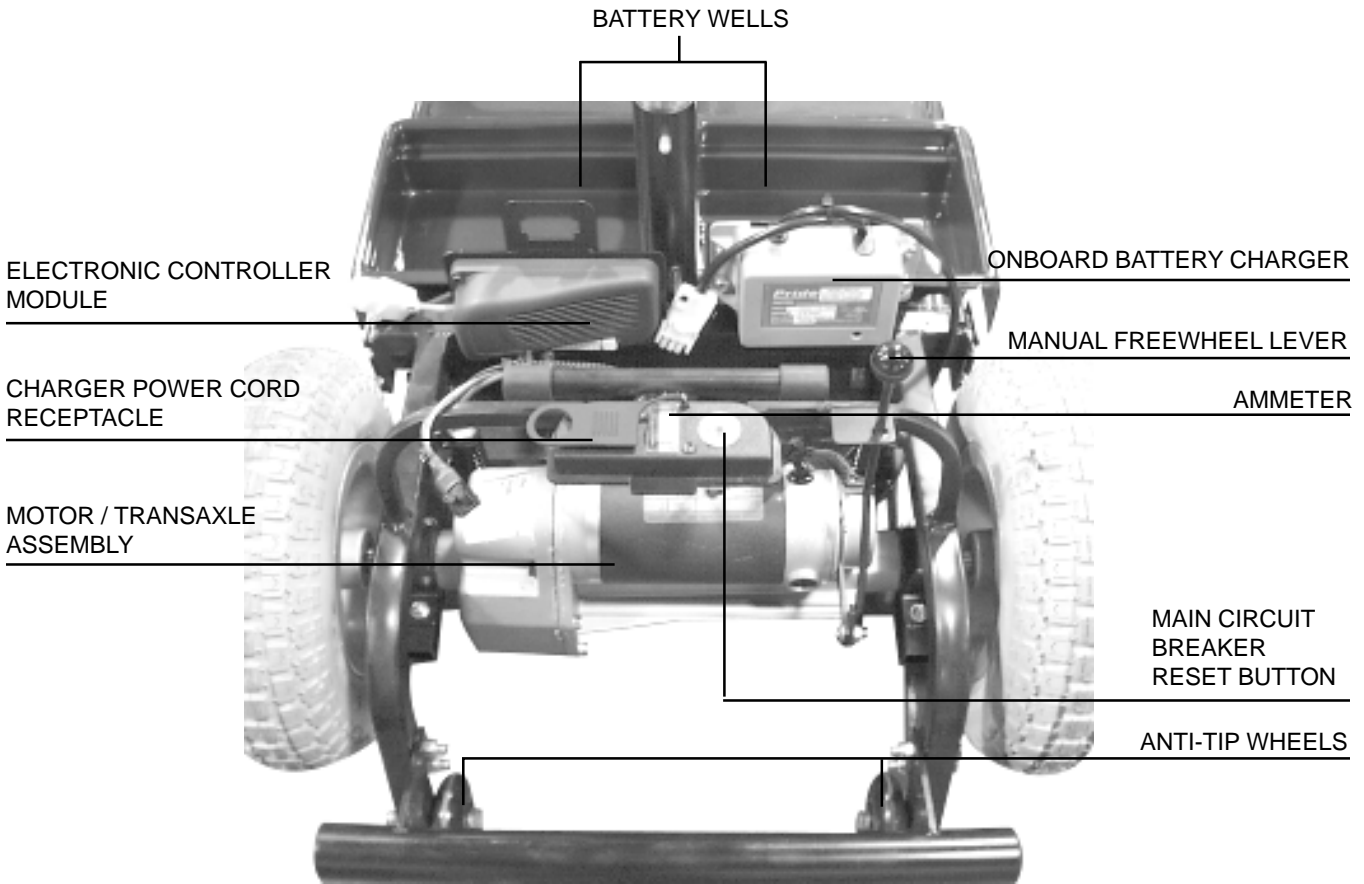

Figure 7. Rear Section

ON-BOARD BATTERY CHARGER

The on-board battery charger converts household current (AC) to direct current (DC) and charges the batteries of your Boxster. See VI. “Batteries and Charging.” The charger is located behind the batteries and at the forward right corner of the rear section. The charger is a gray-colored box with a green LED on the exterior of the case. The charger power cord plugs into your Boxster’s battery charger by means of a receptacle located on the rear section of your Boxster, near the manual freewheel lever and the main circuit breaker reset button. See figure 7.

AMMETER

You can check the charge of you batteries by looking at the ammeter, which is located between the main circuit reset button and the charger power cord receptacle. See figure 7. The battery charger must be plugged into a wall outlet to obtain a reading. When the amperage reading is at or near zero (0) amps, the battery charging is complete.

V. DESCRIPTION

BATTERIES

The batteries store the electrical energy that powers your Boxster. See VI. “Batteries and Charging.”

ELECTRONIC CONTROLLER MODULE

The electronic controller module is located behind the batteries and at the forward left corner of the Boxster’s rear section. This module receives electrical signals from the control console assembly controls and sends power to the motor, the brakes, the light, and the lighting system.

MAIN CIRCUIT BREAKER

When the voltage in your Boxster’s batteries becomes low or your Boxster is heavily strained because of excessive loads or steep inclines, the main circuit breaker may trip to protect your Boxster’s motor and electronics from damage. The main circuit breaker is mounted on the rear section of the Boxster, near the manual freewheel lever. See figure 7.

- The main circuit breaker reset button pops out when the breaker trips.
- When the breaker trips, the entire electrical system of your Boxster is shut down.
- Allow a minute or so for your Boxster’s electronics to “rest.”
- Push in the reset button to reset the breaker.
- If the breaker trips frequently, you may need to charge your batteries more often. You may also need to have your Boxster provider perform a load test on your Boxster’s batteries.
- If the main circuit breaker trips repeatedly, see your authorized Pride provider for service.

MANUAL FREEWHEEL LEVER

Whenever you need or want to push your Boxster for short distances, you can put it in manual freewheel mode.



WARNING! Before placing your Boxster into or taking it out of freewheel mode, make certain that the key is removed from the key switch. Even though the motor of your Boxster is disengaged from the drive system when your PMV is put in manual freewheel mode, the motor can still run if the throttle lever is pushed. Never sit on a PMV when it is in freewheel mode. Never put a PMV in freewheel mode on any incline.

- The manual freewheel lever is located on the end of the motor/transaxle assembly at the right rear of the Boxster. See figure 7.
- Pull up on the manual freewheel lever to disable the drive system and the brake system.
- You will then be able to push your Boxster.
- Push down on the manual freewheel lever to reengage the drive system and the brake system and to take your Boxster out of freewheel mode.

MOTOR/TRANSAXLE ASSEMBLY

The motor/transaxle assembly consists of a geared transmission and differential. This one piece, direct drive, fully sealed assembly provides quiet operation with maximum power and long life. See figure 7.

ANTI-TIP WHEELS

The anti-tip wheels are an integral and important safety feature of your Boxster. Do not, under any circumstances, remove the anti-tip wheels from your Boxster. See figure 7.

VI. BATTERIES AND CHARGING

Your Boxster uses two long-lasting, 12-volt, deep-cycle batteries that are sealed and maintenance free. They are recharged by an on-board 3-amp charging system designed for ease of use and convenience. See figure 7.

- Charge your Boxster's batteries prior to using it for the first time.
- Keep your batteries fully charged to keep your Boxster running trouble free.

Follow these easy steps to charge your batteries safely:



WARNING! Never use an extension cord to plug in your battery charger. Plug the charger directly into a properly wired standard wall outlet.

WARNING! Removal of the grounding prong can create an electrical hazard. If necessary properly install an approved 3-prong adaptor to an electrical outlet having 2-pronged plug access. Failure to heed could result in personal injury and or property damage.

1. Position your Boxster close to a standard wall outlet.
2. Remove the key from the key switch.
3. Make certain that the freewheel lever is in the down (drive) position.
4. Plug the charger power cord into the charger power cord receptacle at the rear of your Boxster. See figure 7.
5. Extend the charger power cord and plug it into the wall outlet.
6. We recommend that you charge your Boxster's batteries for 8 to 14 hours.
7. You can, if you wish, periodically check the battery condition meter by inserting the key in the key switch, examining the battery condition meter, and then removing the key. See figure 6. As the batteries charge, the battery condition meter approaches the 100% reading.
8. When the batteries are fully charged, unplug the charger power cord from the wall outlet and then from the charger power cord receptacle.
9. Place the charger power cord in a safe place for future use.

BATTERIES AND CHARGING - FREQUENTLY ASKED QUESTIONS (FAQS)

How does the charger work?

When your Boxster's battery voltage is low, the charger works extra and sends more electrical current to the batteries to bring up their charge. As the voltage of the batteries approaches a full charge, the charger works less to complete the charging cycle by sending less and less electrical current to the batteries. When the batteries are fully charged, the current being sent to them from the charger is at nearly zero amperage. Therefore, when the charger is plugged in, it maintains the charge on your Boxster's batteries, but it does not overcharge them. We do not recommend that you charge your Boxster's batteries for more than 24 consecutive hours.

Can I use a different charger?

For the safest, most efficient and balanced charging of your Boxster's batteries, we prefer and highly recommend the simultaneous charging of both batteries by use of the on-board battery charger.

VI. BATTERIES AND CHARGING

What does the LED on the Onboard Battery Charger indicate?

The green LED turns on after the batteries have been fully charged. In some instances, the green LED may stay on after the charger has been unplugged from the wall outlet. Although users may perceive this as a charger malfunction, it is a normal condition. The green LED goes off when the batteries reach 26 VDC, which may take a few minutes.

How often must I charge the batteries?

Two major factors must be considered when deciding how often to charge your Boxster's batteries.

- All day PMV use on a daily basis.
- Infrequent or sporadic PMV use.

With these considerations in mind, you can determine just how often and for how long you should charge your Boxster's batteries. We designed the on-board charger so that it does not overcharge your PMV's batteries. However, you may encounter some problems if you do not charge your batteries often enough and if you do not charge them on a regular basis. Following the five guidelines below will provide safe and reliable battery operation and charging.

1. If you use your Boxster daily, charge its batteries as soon as you finish using it for the day. Your Boxster will be ready each morning to give you a "full day" of service. We recommend that you charge your Boxster batteries for 8 to 14 hours after daily use.
2. If you use your Boxster once a week or less, charge its batteries at least once a week for 12 to 14 hours at a time.
3. Keep your Boxster's batteries fully charged.
4. Avoid deeply discharging your Boxster's batteries.
5. Do not charge your Boxster's batteries for more than 24 consecutive hours.

How can I get maximum range or distance per charge?

Rarely will you have ideal driving conditions; smooth, flat, hard driving surfaces with no wind or curves. You will often face hills, sidewalk cracks, uneven and loosely packed surfaces, curves, and wind. All of these driving conditions affect the distance or running time per battery charge. Below are a few suggestions for obtaining the maximum range per battery charge.

- Always fully charge your Boxster's batteries prior to your daily use.
- Maintain 30 psi (pounds per square inch) in all of your Boxster's tires.
- Plan your route ahead to avoid as many hills, cracked, broken, or soft surfaces as possible.
- Limit your baggage weight to essential items.
- Try to maintain an even speed while your Boxster is in motion.
- Avoid stop-and-go driving.

What type and size of battery should I use?

We recommend deep-cycle batteries that are sealed and maintenance free. Both Sealed Lead Acid (SLA) and Gel Cell are deep-cycle batteries that offer similar performance in your Boxster. Do not use wet-cell batteries, which have removable caps.

NOTE: Do not remove the caps from sealed batteries. Water cannot be added to sealed batteries. Cap removal voids the battery warranty and may cause damage to the batteries and to your Boxster.

VI. BATTERIES AND CHARGING

Use these specifications to reorder deep-cycle batteries:

Type: Deep-cycle (sealed lead-acid, or gel cell)
Size: U-1, 40 AH, or NF-22
Voltage: 12 volts each
Amperage: 32 AH, 40 AH, 45 AH, 55 AH (amp hours)

TO CHANGE A BATTERY IN YOUR BOXSTER:



WARNING! Battery posts, terminals and related accessories contain lead and lead compounds. Wash hands after handling.

1. Remove the seat and the rear shroud. See IX “Disassembly and Assembly.”
2. Remove the battery tie-down strap.
3. Disconnect the battery cables from the electronic controller module.
4. Disconnect the battery cables from the battery terminals.
5. Remove the old battery.
6. Place a new battery in the battery well.
7. Connect the red battery cable to the positive (+) battery terminal.
8. Connect the black battery cable to the negative (-) battery terminal.
9. Reconnect the battery cables to the electronic controller module.
10. Fasten the battery tie-down strap.
11. Reinstall the rear shroud and the seat.

Why do my new batteries seem weak?

Deep-cycle batteries employ a different chemical technology than is used in car batteries, nickel-cadmium batteries (nicads), or in other common battery types. Deep-cycle batteries are specifically designed to provide power, drain down their charge, and then accept a relatively quick recharge.

We work closely with our battery manufacturers to provide batteries that best suit your PMV’s specific electrical demands. Fresh batteries arrive daily at Pride and are shipped fully charged to our customers. During shipping, the batteries may encounter temperature extremes that may influence their initial performance. Heat diminishes the charge on the battery; cold slows the available power and extends the time needed to recharge the battery.

It may take a few days for the temperature of your Boxster’s batteries to stabilize and adjust to their new room or ambient temperature.

VI. BATTERIES AND CHARGING

More importantly, it takes a few charging cycles (a partial drain followed by a full recharge) to establish the critical chemical balance that is essential to a deep-cycle battery's peak performance and long life.

Follow these steps to break in your Boxster's new batteries for maximum efficiency and life.

1. Fully recharge any new battery prior to its initial use. This charging cycle brings the battery up to about 88% of its peak performance level.
2. Operate your new Boxster in familiar and safe areas. Drive slowly at first, and do not travel too far from your home or familiar surroundings until you have become accustomed to your Boxster's controls and have properly broken in your PMV's batteries.
3. Fully recharge the batteries. They should now be at over 90% of their peak performance level.
4. Operate your Boxster again.
5. Fully recharge the batteries again.
6. After four or five charging cycles, the batteries are able to receive a charge of 100% of their peak performance level and are able to last for an extended period of time.

How can I ensure maximum battery life?

Fully charged deep-cycle batteries provide reliable performance and extended battery life. Keep your Boxster's batteries fully charged whenever possible. Batteries that are regularly and deeply discharged, infrequently charged, or stored without a full charge may be permanently damaged, causing unreliable performance and limited life.

How should I store my Boxster and its batteries?

If you plan on not using your Boxster for an extended period of time, it is best to:

- Fully charge its batteries prior to storage.
- Disconnect the battery harnesses from the electronic controller module.
- Store your Boxster in a warm dry environment.
- Avoid storing your Boxster where it will be exposed to temperature extremes.



WARNING! If your Boxster's batteries do become frozen, do not attempt to charge them. Cold or frozen batteries should be allowed to warm up for several days prior to recharging.

For prolonged storage, you may wish to place several boards under the frame of your Boxster to raise the PMV off of the ground. This takes the weight off of the tires and prevents the possibility of flat spots from developing on the areas of the tires in contact with the ground.

What about public transportation?

If you intend to use public transportation while using your PMV, you must contact in advance the transportation provider to determine their specific requirements.

VII. OPERATION

GETTING ON YOUR BOXSTER

1. Make certain that the key is removed from the key switch.
2. Stand at the side of your Boxster.
3. Push down on the seat lock lever and rotate the seat until it is facing you.
4. Make certain that the seat is locked securely in position.
5. Position yourself comfortably and securely in the seat.
6. Push down on the seat lock lever and rotate the seat until you are facing forward.
7. Make certain that the seat is locked securely in position.
8. Make certain that your feet are safely on the floorboard.

Follow the checklist below. Familiarize yourself with this checklist, since some of the checks must be performed before you get on your Boxster.

PRE-RIDE ADJUSTMENTS AND CHECKS

- Have you fully charged the batteries? See VI. “Batteries and Charging.”
- Is the manual freewheel lever in the down (drive) position? See V. “Description.”
- Never leave the manual freewheel lever pulled up unless you are manually pushing your Boxster.
- Is your proposed path clear of people, pets, and obstacles?
- Have you planned your route to avoid adverse terrain and as many inclines as possible?
- Are you positioned comfortably in the seat? See “Getting On Your Boxster” above.
- Is the seat at the proper height? See VIII. “Comfort Adjustments.”
- Is the seat locked securely in place? See VIII. “Comfort Adjustments.”
- Is the tiller handle at a comfortable setting and locked securely in place? See VIII. “Comfort Adjustments.”
- Is the key fully inserted into the key switch? See V. “Description.”
- Is the speed adjustment dial set to a lower setting? See V. “Description.”
- Are you grasping the handgrips with a thumb resting on each side of the throttle lever? See V. “Description.”
- Does your Boxster’s horn work properly?

OPERATING YOUR BOXSTER

After planning your route:

- Adjust the speed adjustment dial on the control console assembly to your desired level of speed.
- Press your thumb against the appropriate side of the throttle lever.
- The electric brake automatically disengages and the Boxster accelerates smoothly to the speed preselected at the speed adjustment dial.

WHETHER YOU ARE DRIVING FORWARD OR IN REVERSE:

- Pulling on the left handgrip steers your Boxster to the left.
- Pulling on the right handgrip steers your Boxster to the right.
- Move the tiller to the center position to drive straight ahead.
- Releasing the throttle lever causes your Boxster to decelerate and come to a complete stop.
- The electric brake automatically engages when your Boxster comes to a stop.

VII. OPERATION

NOTE: The rear wheel drive transaxle gives your Boxster maximum traction with minimal steering effort on your part.

GETTING OFF OF YOUR BOXSTER

1. Bring your Boxster to a complete stop.
2. Make certain that the key is removed from the key switch.
3. Push down on the seat lock lever and rotate the seat until you are facing toward the side of your Boxster.
4. Make certain that seat is locked securely in position.
5. Carefully and safely get out of the seat and stand to the side of your Boxster.
6. You may wish to leave the seat facing to the side to facilitate getting on your Boxster the next time you are going to operate it.

AUTO SHUTOFF FEATURE

The Boxster is equipped with an energy saving auto shutoff feature.

- If the Boxster key is left inserted and the PMV remains inactive for approximately 20 minutes, the PMV will shut down. This feature is designed to preserve battery life.

To restore power back to the Boxster:

- Remove the key from the key switch.
- Insert the key back into the key switch.

Your Boxster will now resume normal operation.

VIII. COMFORT ADJUSTMENTS

TILLER ANGLE ADJUSTMENT



WARNING! Remove the key before adjusting the tiller.

You can adjust the tiller to many positions. The tiller adjustment lever locks the tiller in place. It has a spring-loaded mechanism that enables you to rotate it and change its position.

1. Turn the tiller adjustment lever counterclockwise until it is loose. If the tiller adjustment lever comes in contact with the tiller basket, pull it outward, turn it clockwise, and release it. Continue to loosen until the tiller is able to move. See figures 8A and 8B.
2. Move the tiller to a comfortable position.
3. Turn the tiller adjustment lever clockwise until it is tight. If the tiller adjustment lever comes in contact with the tiller basket, pull it outward, turn it counterclockwise, and release it. Continue to turn the lever until it is tight. The tiller may be lowered to the center of the floorboard and locked in place for storage. See IX. "Disassembly and Assembly."

(TILLER BOOT SHADOWED FOR CLARITY)

TILLER ADJUSTMENT
LEVER

TILLER BOOT

RELEASE BUTTON

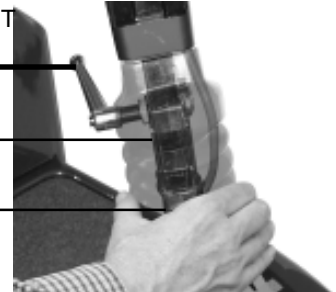

Figure 8a. Adjusting the Tiller Angle

LEVER (TILLER BOOT REMOVED FOR
CLARITY)

PULL OUT TO
REPOSITION



Figure 8b. Reposition Tiller Adjustment

SEAT HEIGHT ADJUSTMENT

The seat can be repositioned to one of three different heights. See figure 9.

1. Remove the seat from your Boxster. See IX. "Disassembly and Assembly."
2. Use the attached ring to pull and remove the ball detent pin from the lower seat post.
3. Raise or lower the upper seat post to the desired seat height.
4. While holding the upper seat post at that height, match up the holes in the upper seat post and the lower seat post.
5. Fully insert the ball detent pin.
6. Replace the seat.

UPPER SEAT POST

LOCATING HOLES

BALL DETENT PIN

LOWER SEAT POST

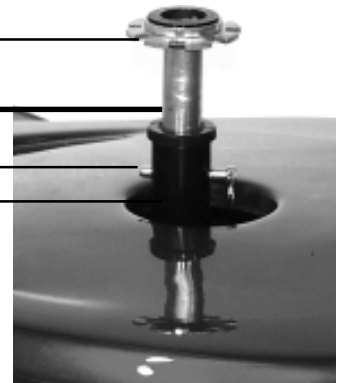

Figure 9. Seat Height Adjustment

VIII. COMFORT ADJUSTMENTS

FRONT-TO-BACK SEAT ADJUSTMENT

You can reposition the Boxster's seat forward or rearward to adjust the distance between the seat and the tiller. See figure 10.

1. Disengage the seat sliding lever.
2. While holding the lever up, slide the seat forward or rearward.
3. Release the seat sliding lever once the seat is in the desired position.

SEAT ROTATION

The seat lock lever locks the seat in one of different positions. See figure 10.

1. Pull up on the seat lock lever to unlock the seat.
2. Rotate the seat to the desired position.
3. Release the seat lock lever to lock the seat securely in place.

SEATBACK ADJUSTMENT

To adjust your Boxster's reclining seat, perform these steps. See figure 11.

1. While pulling up on the seat recline lever, lean forward or backward to adjust the seatback.
2. Release the seat reclining lever once the seat is in a comfortable riding position.



WARNING! Always keep your back pressed firmly against the seatback while adjusting the angle.



WARNING! Do not operate the Boxster with the seat in the reclined position.

ARMREST ANGLE ADJUSTMENT

The armrests of your Boxster can be adjusted upward or downward. See figure 12.

By turning the adjustment dial, the armrest will either raise or lower. The armrests also pivot upward to make getting on and off of your Boxster easier.

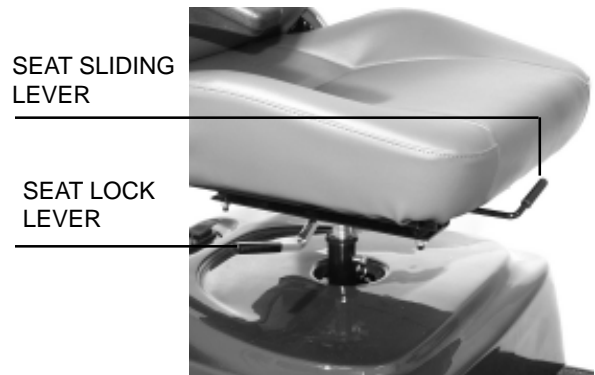

Figure 10. Sliding Seat Adjustment



Figure 11. Seatback Adjustment Lever



Figure 12. Armrest Angle Adjustment

IX. DISASSEMBLY AND ASSEMBLY

The Boxster requires no tools for disassembly. Always disassemble or assemble your Boxster on a level, dry surface with sufficient room for you to work and move around your PMV. Keep in mind that the disassembled sections of the Boxster will take up more floor space than the assembled Boxster.

DISASSEMBLY

1. Remove the key from the key switch.
2. Pull up on the manual freewheel lever. Putting your Boxster in freewheel may make it easier for you to maneuver the rear section because the drive wheels are free to turn.
3. Make certain that the seat is locked into position (see VIII. "Comfort Adjustments") and lift the seat up and off of your Boxster.
4. Gently lift the rear shroud off of your Boxster. The rear shroud is held in place with Velcro.
5. Disconnect the battery straps, then unplug both battery harnesses. See figure 13.
6. Lift both batteries from the battery wells.



CAUTION! Failing to unplug both battery harnesses and the front-to-rear connector prior to further disassembly could result in permanent damage to your Boxster.

7. Unplug the large, white, 9-pin front-to-rear connector that connects the control console assembly harness to the electronic controller module harness. See figure 14.
8. Turn the tiller adjustment lever counterclockwise until it is loose. Pull the rubber boot upward to expose the tiller release buttons. With one hand on the rear of the tiller, carefully depress both tiller release buttons while slowly lowering the tiller to the center of the floorboard. See figure 8A.
9. Remove the ball detent pin from the frame. See figure 15.
10. Move the camlocks to the unlocked, (vertical), position. See figure 15.
11. With one hand on the seat pedestal and one hand on the front frame handle, gently slide the front and rear sections apart. See figure 16.

UNPLUG
HERE



Figure 13. Battery Harnesses

UNPLUG
HERE



Figure 14. Front-to-Rear Connector

UNLOCKED
POSITION

BALL DETENT
PIN

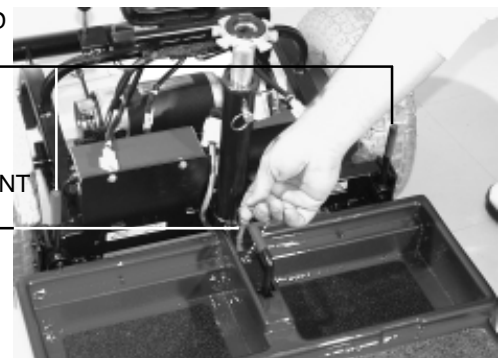

Figure 15. Frame Locking Levers / Ball Detent Pin

IX. DISASSEMBLY AND ASSEMBLY

ASSEMBLY

1. Pull up on the manual freewheel lever. Putting your Boxster in freewheel may make it easier for you to maneuver the rear section because the drive wheels are free to turn. See figure 7.
2. Position the front and rear sections of your Boxster as shown in figure 16.
3. Align the lower slots on the rear of the front section to the corresponding pegs on the front of the rear section. See figure 17.
4. Gently push the front section of your Boxster towards the rear section until the curved locking brackets are fully connected onto the rear pegs.
5. Insert the ball detent pin.
6. Place the frame locking levers in the locked position. See figure 18.
7. Raise the tiller to the upright position by turning the tiller adjustment lever until it is loose. Raise the tiller to the desired position. Verify that the tiller release buttons are reengaged, and the tiller adjustment lever is tight.
8. Connect the large, white, 9-pin front-to-rear connector (located on the harness coming out of the Boxster's front section) to the connector's mating socket (found near the front of the Boxster's rear section). See figure 14.
9. Place the batteries in the battery wells (see figure 18) then reconnect the battery straps.
10. Connect the 2-pin battery harnesses into the mating harnesses that extend from the electronic controller module. See figure 13.
11. Gently place the rear shroud over the seat pedestal and slide it down into position. The Velcro fasteners will hold it in place.
12. Carefully lift the seat and slide the seat post (on the bottom of the seat frame) into the seat pedestal.
13. Rotate the seat until it locks into place to complete the assembly of your Boxster.

POSITION FRONT AND REAR SECTIONS

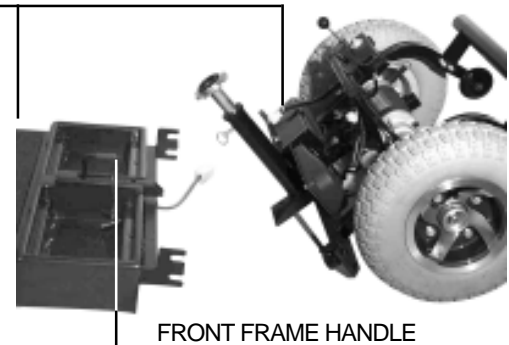

Figure 16. Front and Rear Sections

CONNECT FRAME HALVES HERE

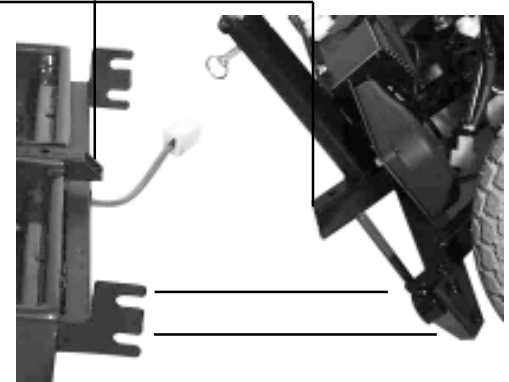

Figure 17. Frame Lock

LOCKED POSITION

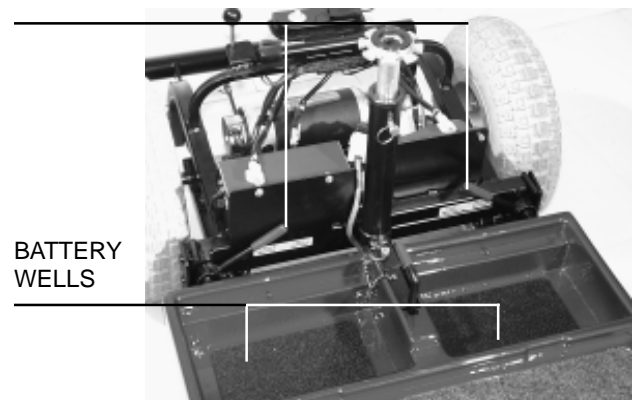

Figure 18. Frame Locking Levers

X. BASIC TROUBLESHOOTING

Any electromechanical device occasionally requires some troubleshooting. However, most of the problems that may arise can usually be solved with a bit of thought and common sense. Many of these problems occur because the batteries are not fully charged or because the batteries are worn down and can no longer hold a charge.

What if all the systems on my Boxster seem to be “dead”?

- Make certain that the key is fully inserted in the key switch.
- Check that the batteries are fully charged. See VI. “Batteries and Charging.”
- Push in to reset the main circuit breaker. See V. “Description.”
- Make certain that both battery harnesses are firmly connected to the electronic controller module and to the battery terminals. See IX. “Disassembly and Assembly.”
- Make sure that the front-to-rear harness connector is firmly connected. See IX. “Disassembly and Assembly.”
- Be sure that the auto shutoff feature has not been activated. See VII. “Operation.”

What if the motor runs but my Boxster does not move?

- Your Boxster was probably left in manual freewheel mode.
- When the freewheel lever is pulled up, the brakes are disengaged and all power to the transaxle is cut. Push down the freewheel lever to restore normal operation to your Boxster. See V. “Description.”

What if the main circuit breaker repeatedly trips? See V. “Description.”

- Charge the Boxster’s batteries more frequently. See VI. “Batteries and Charging.”
- If the problem continues, have both of your Boxster’s batteries load tested by your authorized Pride provider.
- Or, battery load testers are available at most automotive parts stores. Follow the directions supplied with the load tester. See VI. “Batteries and Charging” or IV. “Specifications” for information about your Boxster’s battery type.

What if the battery condition meter dips way down and the motor surges or hesitates when I press my Boxster’s throttle control lever? See V. “Description.”

- Fully charge your Boxster’s batteries. See VI. “Batteries and Charging.”
- Have your authorized Pride provider load test each battery.
- Or, see the previous troubleshooting question for load testing the batteries yourself.

If you experience any problems with your Boxster that you are not able to handle, immediately contact your authorized Pride provider for information, maintenance, and service.

XI. CARE AND MAINTENANCE

Your Boxster requires a minimal amount of care and maintenance. If you do not feel confident of your ability to perform the maintenance listed below, you may schedule inspection and maintenance at your authorized Pride provider.

The following areas require periodic inspection and care and maintenance.

TIRE PRESSURE:

We recommend that the tire pressure be maintained at 30 psi. For optimum PMV performance, do not exceed that pressure; overinflating a tire can cause it to explode.

TIRE CONDITION AND TREAD WEAR:

Regularly inspect your Boxster's tires for signs of wear. Using a rubber conditioner on your Boxster's tires helps to preserve them.

Do not put rubber conditioner on tread area of tires. The tires may become dangerously slippery.

REMOVABLE FLOORMAT:

Your Boxster's carpet floor mat is held on with Velcro fasteners. It can be removed, cleaned, and reinstalled as necessary.

EXTERIOR SURFACES:

Bumpers and trim also benefit from an occasional application of rubber or vinyl conditioner.

Do not use a rubber or vinyl conditioner on the Boxster's vinyl seat; the seat may become dangerously slippery.

BATTERY TERMINAL CONNECTIONS:

- Make certain that the terminal connections remain tight and uncorroded.
- The batteries must sit flat in the battery wells.
- The battery terminals should face the rear of the Boxster.

WIRING HARNESES:

- Regularly check all wiring connections.
- Regularly check all wiring insulation, including the charger power cord, for wear or damage.
- Repair or replace any damaged connector, connection, or insulation that you find before using your Boxster again.

ABS PLASTIC SHROUDS:

The front console shroud and the rear shroud are formed from durable ABS plastic and coated with an advanced formula urethane paint. A light application of car wax helps the shrouds retain their high gloss.

AXLE BEARINGS AND THE MOTOR/TRANSAXLE ASSEMBLY:

These items are all prelubricated, sealed, and require no subsequent lubrication.

CONSOLE, CHARGER, AND ELECTRONIC CONTROLLER MODULE:

Keep these areas free of moisture. If any of these items do become exposed to moisture, let them dry thoroughly before operating your Boxster again.

STORAGE:

See VI. "Batteries and Charging."

XII. OPTIONAL ACCESSORIES

For information concerning these optional accessories see your authorized Pride provider.



• Flag



• Rear Basket

XIII. WARRANTY

THREE-YEAR LIMITED WARRANTY

Structural frame components; including platform, fork, seat post, and frame.

Drive train; including transaxle, motor, and brake.

First year: 100% replacement of parts cost

Second year: 67% replacement of parts cost

Third year: 50% replacement of parts cost

THREE-YEAR WARRANTY EXCEPTIONS

Transaxle: In cases where there is an increase in the operational noise level, the warranty does not apply. (The increase in operational noise level usually occurs due to abusive and excessive strain on the PMV.)

Motor: If damage occurs to the motor commutator as a result of not replacing the motor brushes after heavy wear to the brushes. Motor brushes are wear items and are not warranted.

Motor brake: Three-year warranty for the electrical function of the motor brake. Brake pads are a wear item and will not be warranted.

ONE-YEAR LIMITED WARRANTY

For one year from the date of purchase, Pride will repair or replace, at our option, to the original purchaser, free of charge, any part found upon examination by an authorized representative of Pride to be defective in material and/or workmanship.

The battery is warranted by the battery manufacturer. The battery is not warranted by Pride.

Warranty service can be performed by a provider authorized by Pride or by Pride. Do not return faulty parts to Pride without prior consent. All transportation costs and shipping damage incurred while submitting parts for repair or replacement are the responsibility of the original purchaser.

WARRANTY EXCLUSIONS

- ABS plastic shrouds and footrest covers (wear items and not warranted)
- Batteries (the battery manufacturer provides a six-month limited warranty)
- Tires and tire tubes (wear items and not warranted)
- Upholstery and seating (wear items and not warranted)
- Repairs and/or modifications made to any part of the PMV without specific and prior consent from Pride
- Circumstances beyond the control of Pride
- Damage caused by:
 - √ Battery fluid spillage or leakage
 - √ Abuse, misuse, accident, or negligence
 - √ Improper operation, maintenance, or storage
 - √ Commercial use or use other than normal
- Labor, service calls, shipping, and other charges incurred for repair of the product

XIII. WARRANTY

There is no other express warranty.

Implied warranties, including those of merchantability and fitness for a particular purpose, are limited to one (1) year from the date of original purchase and to the extent permitted by law. Any and all implied warranties are excluded. This is the exclusive remedy. Liabilities for consequential damages under any and all warranties are excluded.

Some states do not allow limitations on how long an implied warranty lasts or do not allow the exclusion of limitation of incidental or consequential damages. So, the above limitation or exclusion may not apply to you.

The warranty gives you specific rights, and you may also have other rights, which vary from state to state.

Please fill out the warranty card and mail it to Pride. Doing so aids Pride in providing you with the best possible technical and customer service.

NOTES



Pride
Mobility Products Corp.

182 Susquehanna Avenue
Exeter, PA 18643
1-800-800-8586

www.pridemobility.com