



# Installation and Operation Manual

## **BISTRO LINE**

Gas-Fired Stone Hearth Oven  
*Commercial Dual Burner, Pita Oven Models*



**BISTRO 4836 (PITA OVEN)**  
WS-BL-4836-RFG-LR-(NG, LP)

**BISTRO 4343 (PITA OVEN)**  
WS-BL-4343-RFG-LR-(NG, LP)

**BISTRO 4355 (PITA OVEN)**  
WS-BL-4355-RFG-LR-(NG, LP)

**CUSTOM MODELS (PITA OVEN)**

CS-REC-8-RFG-LR-(NG, LP)

CS-REC-9-RFG-LR-(NG, LP)

CS-REC-11-RFG-LR-(NG, LP)



**WoodStone**

**wood stone corporation**  
1801 w. bakerview rd.  
bellingham, wa 98226 usa

tf. 800.988.8103  
t. 360.650.1111  
f. 360.650.1166

**woodstone-corp.com**  
Revised April 2015  
Doc no: M0028.02



### TABLE OF CONTENTS

TABLE OF CONTENTS . . . . .	2
DUAL BURNER OVEN . . . . .	3
CAUTIONS AND WARNINGS . . . . .	4
BL-4836-LR (REC-8) SPECIFICATIONS . . . . .	6
BL-4343-LR (REC-9) SPECIFICATIONS . . . . .	7
BL-4355-LR (REC-11) SPECIFICATIONS . . . . .	8
MOVING THE OVEN . . . . .	9
INSTALLATION CLEARANCES . . . . .	10
OVEN VENTING . . . . .	11
HOOD SPECIFICATIONS . . . . .	12
DISASSEMBLY . . . . .	13
LIFTING THE OVEN . . . . .	15
EXPLODED PARTS DIAGRAM . . . . .	17
ASSEMBLY . . . . .	18
CONTROLLER . . . . .	24
INITIAL START-UP . . . . .	25
OVEN OPERATION . . . . .	26
DAILY MAINTENANCE . . . . .	27
TROUBLESHOOTING GUIDE . . . . .	28
120 VAC ELECTRICAL DIAGRAM . . . . .	29
240 VAC ELECTRICAL DIAGRAM . . . . .	30
INTERLOCK DIAGRAM . . . . .	31
LIMITED WARRANTY . . . . .	32



### INSTALLATION AND OPERATION MANUAL FOR THE WOOD STONE DUAL BURNER BISTRO

#### NATURAL GAS OR PROPANE FUELED DUAL BURNER STONE HEARTH OVEN

**WS-BL-4836-RFG-LR-(NG OR LP)**

**WS-BL-4343-RFG-LR-(NG OR LP)**

**WS-BL-4355-RFG-LR-(NG OR LP)**

**CS-REC-8-RFG-LR-(NG OR LP)**

**CS-REC-9-RFG-LR-(NG OR LP)**

**CS-REC-11-RFG-LR-(NG OR LP)**

#### ADDITIONAL COPIES AVAILABLE UPON REQUEST



Shown: BL-4343-RFG-LR



### INSTALLATION AND OPERATION MANUAL FOR THE WOOD STONE DUAL BURNER BISTRO NATURAL GAS (NG) OR PROPANE (LP) FUELED DUAL BURNER STONE HEARTH OVEN

**WS-BL-4343-RFG-LR-(NG OR LP),**

**WS-BL-4355-RFG-LR-(NG OR LP),**

**WS-BL-4836-RFG-LR-(NG OR LP),**

**CS-REC-(8, 9, 11)-RFG-LR-(NG OR LP)**

#### RETAIN THIS MANUAL FOR FUTURE REFERENCE

Additional copies of this manual at [woodstone-corp.com](http://woodstone-corp.com).

For prompt responses to service/maintenance questions, call us at @ 1-800-988-8103.

#### READ ALL INSTRUCTIONS BEFORE INSTALLING AND USING THIS APPLIANCE

Please read this entire manual before you install the oven. Failure to follow instructions may result in property damage, bodily injury or even death. Contact your local building or fire officials about restrictions and installation inspection in your area.

**WARNING:** Improper installation, adjustment, alteration, service or maintenance can result in property damage, injury or death. Read the installation, operation and maintenance instructions thoroughly before installing or servicing this equipment.

**AVERTISSEMENT:** L'installation, le réglage, la modification, la réparation ou l'entretien incorrect de cet appareil peut causer des dommages matériels, de blessures ou la mort. Lire attentivement les instructions d'installation, de fonctionnement et d'entretien avant de procéder à son installation ou entretien.

**IMPORTANT:** Consult your local gas supplier for a statement outlining a procedure to be followed in the event you smell gas. Post the statement in a prominent location.

When this oven is not properly installed, a fire may result. To reduce the risk of fire, follow the installation instructions. It is recommended that this oven be installed, maintained and serviced by authorized professionals.

**WARNING:** This product must be installed by a licensed plumber or gas fitter when installed within the Commonwealth of Massachusetts.



**A MAJOR CAUSE OF OVEN RELATED FIRES IS A FAILURE TO MAINTAIN REQUIRED CLEARANCES TO COMBUSTIBLE MATERIAL. IT IS OF UTMOST IMPORTANCE THAT THIS OVEN BE INSTALLED ONLY IN ACCORDANCE WITH THESE INSTRUCTIONS.**

**FOR YOUR SAFETY:** Do not store or use gasoline or other flammable vapors or liquids in the vicinity of this or any other appliance.

**POUR VOTRE SÉCURITÉ:** Ne pas entreposer ni utiliser d'essence ou d'autres vapeurs de liquides inflammables ou des liquides dans les environs de ce ou de tout autre appareil.



This appliance is for professional use by qualified personnel. This appliance must be installed by qualified persons in accordance with the regulations in force. This appliance must be installed with sufficient ventilation to prevent the occurrence of unacceptable concentrations of substances harmful to health in the room in which it is installed. This appliance needs an unobstructed flow of fresh air for satisfactory combustion and must be installed in a suitably ventilated room in accordance with current regulations. This appliance should be serviced by qualified personnel at least every 12 months, or sooner if heavy use is expected.

### SAVE THE INSTRUCTIONS

Wood Stone's Gas-Fired Bistro Dual Burner ovens have been tested and approved by Intertek Testing Services and are ETL listed to ANSI Z83.11b-2009 / CSA 1.8b-2009 and to NSF/ANSI Standard 4 - 2009.



Intertek



Intertek



Plan view

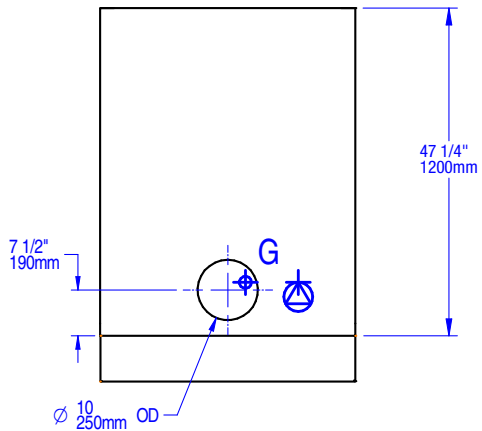

Rear view

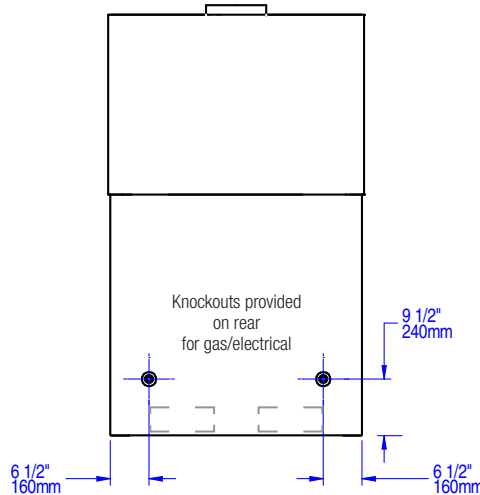

- Air intake: Do not facade or cover over
- Must be left removable for service

**Actual weight**

**1,650 lbs.**

**Shipping weight**

**1,800 lbs.**

Front view

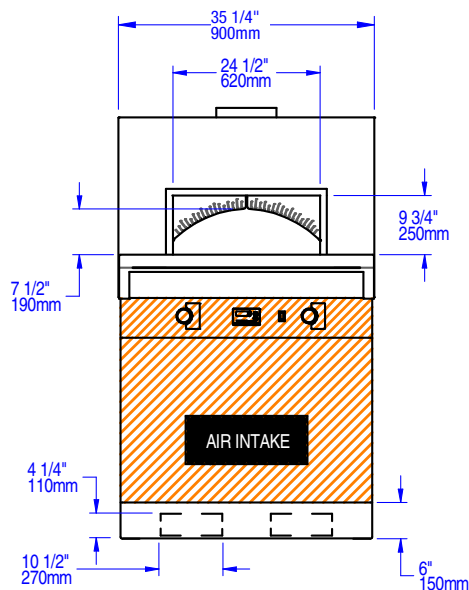

Side view

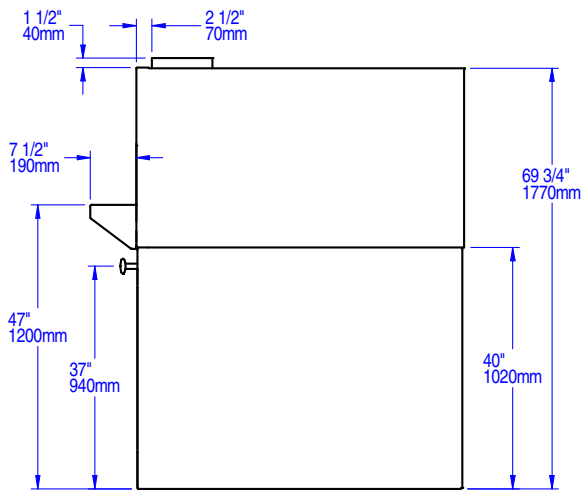

**UTILITIES SPECIFICATIONS**

**Gas:** 3/4 inch FNPT gas inlet  $\phi$ G  
105,000 BTU/hr Natural Gas (NG)  
OR  
100,000 BTU/hr Propane (LP)

**Maximum gas inlet pressure**  
1/2 psi (14 inches W.C.)

**Electrical**

120 VAC, 2 A, 50/60 Hz  $\text{⚡}$   
Optional: 240 VAC, 1 A, 50/60 Hz  
All utility connections made on the back of the oven control box. Remove front or rear panel for access. Use utility knockouts (provided) to route gas and electrical supplies. Refer to data plate when installing.

**Venting:** The Dual Burner Bistro has a 10" O.D. flue collar and can be direct connected to a power-ventilated, grease-rated chimney or can be vented with a Listed Type 1 exhaust hood, or one constructed in accordance with NFPA 96 and all relevant local and national codes. The oven must be vented in accordance with all relevant local and national codes, and in a manner acceptable to the authority having jurisdiction.



Plan view

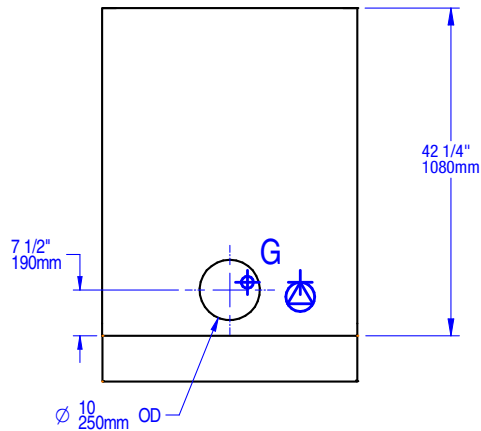

Rear view

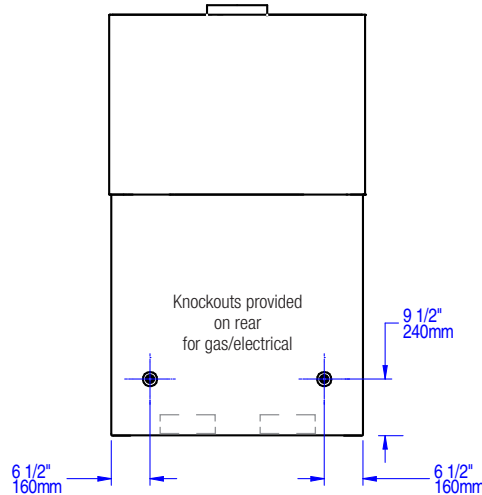

- Air intake: Do not facade or cover over
- Must be left removable for service

**Actual weight**  
**1,650 lbs.**

**Shipping weight**  
**2,100 lbs.**

Front view

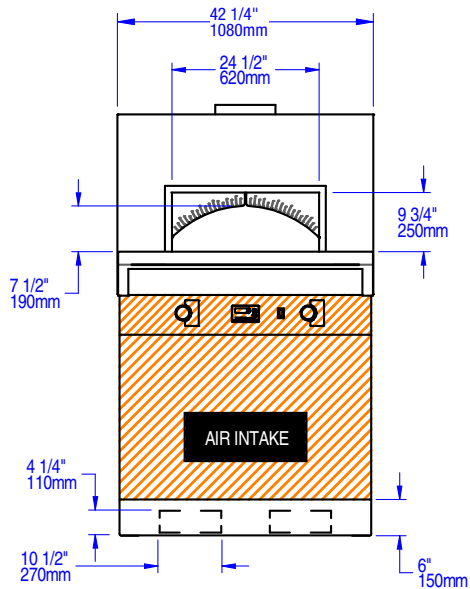

Side view

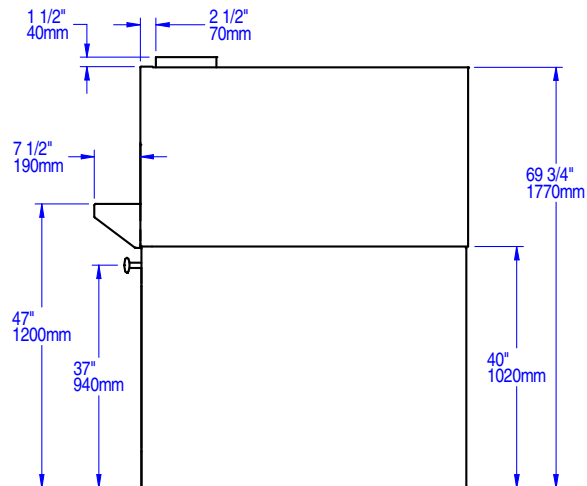

### UTILITIES SPECIFICATIONS

**Gas:** 3/4 inch FNPT gas inlet  $\phi$  G  
105,000 BTU/hr Natural Gas (NG)  
OR  
100,000 BTU/hr Propane (LP)  
**Maximum gas inlet pressure**  
1/2 psi (14 inches W.C.)

### Electrical

120 VAC, 2 A, 60 Hz  $\text{⚡}$   
Optional: 240 VAC, 1 A, 60 Hz  
All utility connections made on the back of the oven control box. Remove front or rear panel for access. Use utility knockouts (provided) to route gas and electrical supplies. Refer to data plate when installing.

**Venting:** The Dual Burner Bistro has a 10" O.D. flue collar and can be direct connected to a power-ventilated, grease-rated chimney or can be vented with a Listed Type 1 exhaust hood, or one constructed in accordance with NFPA 96 and all relevant local and national codes. The oven must be vented in accordance with all relevant local and national codes, and in a manner acceptable to the authority having jurisdiction.



Plan view

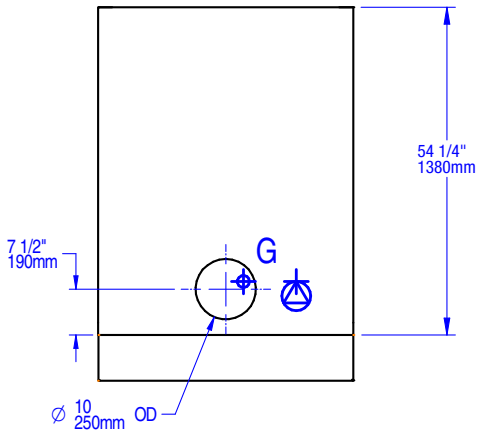

Rear view

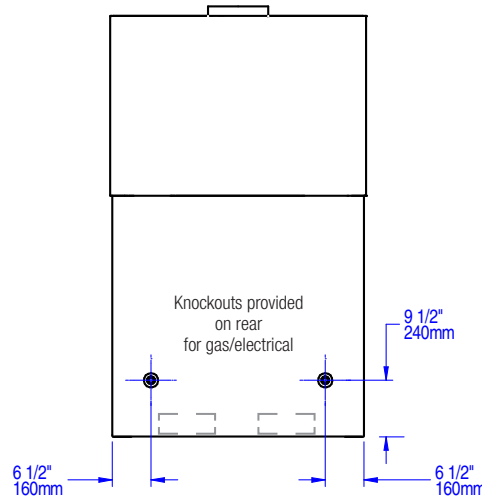

- Air intake: Do not facade or cover over
- Must be left removable for service

**Actual weight**  
**2,200 lbs.**

**Shipping weight**  
**2,500 lbs.**

Front view

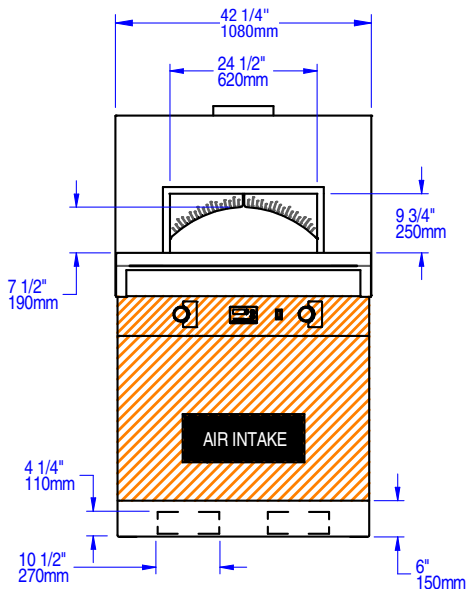

Side view

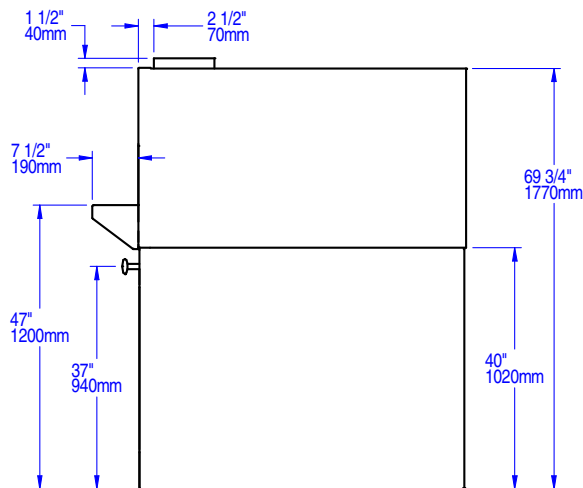

**UTILITIES SPECIFICATIONS**

**Gas:** 3/4 inch FNPT gas inlet  $\phi$  G  
151,000 BTU/hr Natural Gas (NG)  
OR  
151,000 BTU/hr Propane (LP)

**Maximum gas inlet pressure**  
1/2 psi (14 inches W.C.)

**Electrical**

120 VAC, 2 A, 60 Hz  $\text{\textcircled{P}}$   
Optional: 240 VAC, 1 A, 60 Hz  
All utility connections made on the back of the oven control box. Remove front or rear panel for access. Use utility knockouts (provided) to route gas and electrical supplies. Refer to data plate when installing.

**Venting:** The Dual Burner Bistro has a 10" O.D. flue collar and can be direct connected to a power-ventilated, grease-rated chimney or can be vented with a Listed Type 1 exhaust hood, or one constructed in accordance with NFPA 96 and all relevant local and national codes. The oven must be vented in accordance with all relevant local and national codes, and in a manner acceptable to the authority having jurisdiction.





The oven can be moved over a flat surface with a pallet jack using the **LOWER** forklift pockets. If the oven is to be installed against a wall, you may need to leave access to the back of the oven to complete the utility connections.

### PLACING THE OVEN

The oven must be installed on a flat level surface. The weight of the oven is carried by the full perimeter of the oven stand. If it is necessary to shim the oven for leveling purposes, it is critical that the shim material be metal, and that the shims are installed in such a way that the full perimeter of the stand is solidly supported. Any gaps created by shimming between the oven and the floor must be sealed for proper ventilation. **Failure to solidly support the full perimeter of the oven stand can result in costly damage to the oven and will void the warranty.**

The floor design and construction must be adequate to handle the weight of the oven.  
Please see [woodstone-corp.com/installation\\_footprints.htm](http://woodstone-corp.com/installation_footprints.htm) for floor loading information.

### FORKLIFT REQUIREMENTS

The oven is very top-heavy. **IF THE OVEN TIPS IT CAN CAUSE SEVERE INJURY OR DEATH! NEVER ATTEMPT TO USE A HAND TRUCK TO MOVE THE OVEN.** The oven should only be moved using a pallet jack on a **LEVEL FLOOR**. If the oven must be moved over an inclined surface, a forklift or other suitable means should be employed. If the installer does not have the equipment or experience required to move the **oven safely, we recommend you secure the services of a qualified rigging company.**

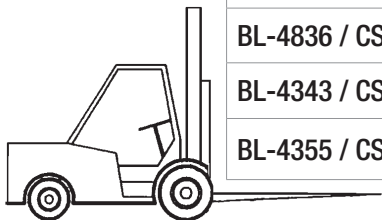

Model	Shipping Weight (lbs/kg)	Required Forklift Capacity (lbs/kg)	Minimum Fork Length (ft/m)
BL-4836 / CS-REC-8	1,800lbs / 862kg	3,200lbs / 1,451kg	5' / 1.5M
BL-4343 / CS-REC-9	2,100lbs / 953kg		
BL-4355 / CS-REC-11	2,500lbs / 1,134 kg		

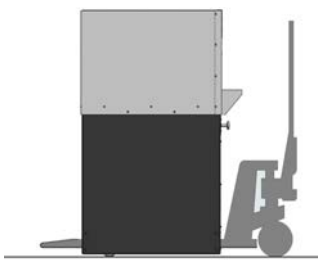

The oven should only be moved using a pallet jack on a **LEVEL FLOOR**. If the oven must be moved over an inclined surface, a forklift or other suitable means should be employed.

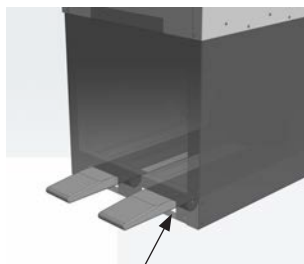

Make sure the pallet jack wheels do not contact the underside of the fork pocket when lifting to avoid damaging the stand.

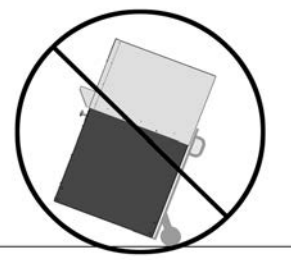

Never attempt to use a hand truck to move the oven.



**WARNING:** Do not pack required air spaces (clearance) with insulation or other material.  
**EN AVERTISSANT** - n'emballez pas les espaces aériens requis avec l'isolation ou tout autre matériel.  
When non-combustible building materials contact the body of the oven, the clearances to combustibles are transferred to those non-combustibles.



**WARNING:** Installation and servicing of this product could expose you to glasswool/ceramic fibers as well as calcium silicate dust. **ALWAYS WEAR RESPIRATORY AND EYE PROTECTION WHEN INSTALLING OR SERVICING THIS APPLIANCE.** Please read this entire manual before you install the oven. Failure to follow instructions may result in property damage, bodily injury or even death. Contact your local building or fire officials about restrictions and installation inspection in your area.

### CLEARANCES

1. The Wood Stone Bistro oven should have a **minimum 1-inch clearance to combustibles from all sides, 6-inch clearance to combustibles from the top, and 6-inch clearance from the exhaust transition and flue collar.** Any facade wall built 6 inches to either side of the doorway and above must be of non-combustible construction. If building a facade that will contact the oven, use completely non-combustible materials. Please note that standard Drywall (or Sheetrock) is considered a limited combustible. Any walls perpendicular to the front of the oven in the area 30 inches to either side of the doorway and 36 inches in front of the oven should have a non-combustible surface.
2. This oven should be installed on a non-combustible floor surface. For use only on noncombustible floors (installé sur un plancher incombustible seulement). The non-combustible floor surface must extend 36 inches in front of and 30 inches to either side of the oven doorway.

**NOTICE:** For stucco-ready appliances (model numbers ending in "-S"), the same clearances as described above apply. Non-combustible stucco mix must be used and applied to a minimum thickness of 1".

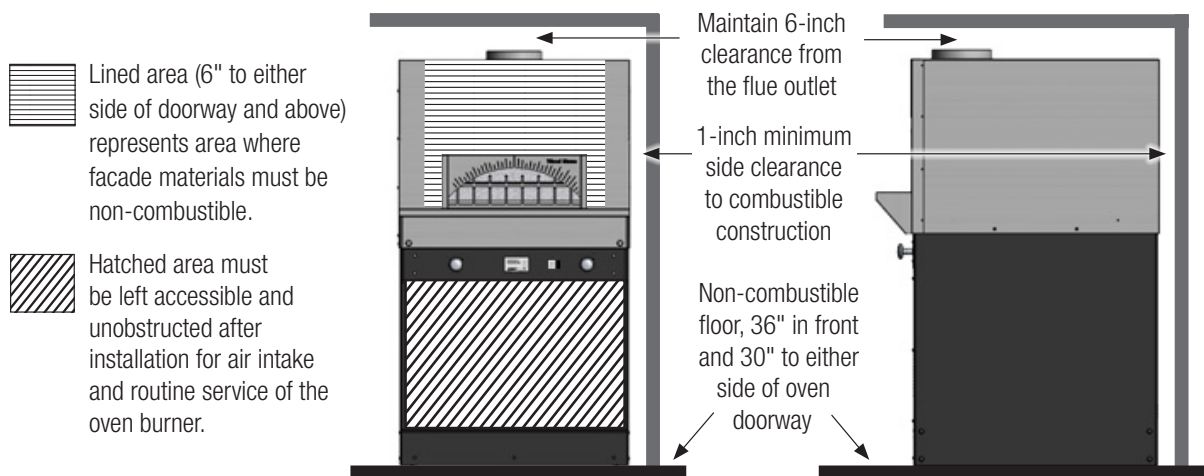



All of the combustion products and cooking vapors from all Dual Burner Bistros pass through the 10-inch diameter flue collar located on top of the oven at the front. The oven can be connected to a power-ventilated, grease-rated chimney, or placed under a Listed Type 1 exhaust hood. Installation of the exhaust hood should be in accordance with the Standard for Ventilation Control and Fire Protection of Commercial Cooking Operations, NFPA 96.

**THIS OVEN IS NOT INTENDED TO BURN SOLID FUEL.  
DO NOT BURN ANY TYPE OF SOLID FUEL IN THIS OVEN.**

The following are the manufacturer's recommendations for venting Wood Stone Dual Burner Bistro model ovens. It is never appropriate to use "B vent" in any part of an exhaust system connected to a Wood Stone oven. All duct material must be manufactured to the specifications of a grease duct. The venting system should be cleaned and inspected at least every 3 months.

**THERE ARE TWO VENTING OPTIONS:**

1. A Listed building heating appliance chimney, also listed as a grease duct connected directly to the oven flue collar and provided with a power ventilator listed for restaurant appliance exhaust and rated for operation at a minimum of 300 °F. Use a stack or curb mounted fan. Wood Stone does not recommend the use of an in-line fan. A field built grease duct installed and constructed according to the requirements spelled out in NFPA 96, or the International Mechanical Code.  
A static pressure of -0.1 inches water column is necessary at the oven flue collar to ensure proper flue temperatures at the fan. The airflow required to attain this static pressure will be approximately 400 CFM. The exhaust fan must be turned on any time the oven is running. See instructions for optional interlocking of the oven to the fan at the end of this manual.
2. A Listed Type 1 exhaust hood or one that is constructed and installed in accordance with all relevant local and national Codes. Wood Stone offers eyebrow-type hoods designed specifically for Wood Stone ovens. See specification sheet on ventilators for Wood Stone ovens.

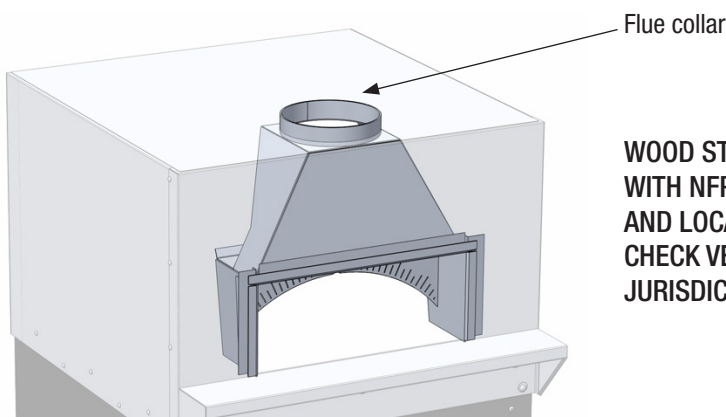

**WOOD STONE OVENS SHOULD BE VENTED IN ACCORDANCE WITH NFPA 96 AND/OR ALL PERTINENT NATIONAL, REGIONAL AND LOCAL CODES CONCERNING SUCH APPLIANCES. CHECK VENTING PLANS WITH THE AUTHORITY HAVING JURISDICTION BEFORE PROCEEDING WITH INSTALLATION.**

**Wood Stone Hoods by Gaylord Specifications**  
**Required CFM - 625 CFM**  
**Static Pressure - 0.80" W.C.**  
**Duct Collar - 7" x 7" I.D.**

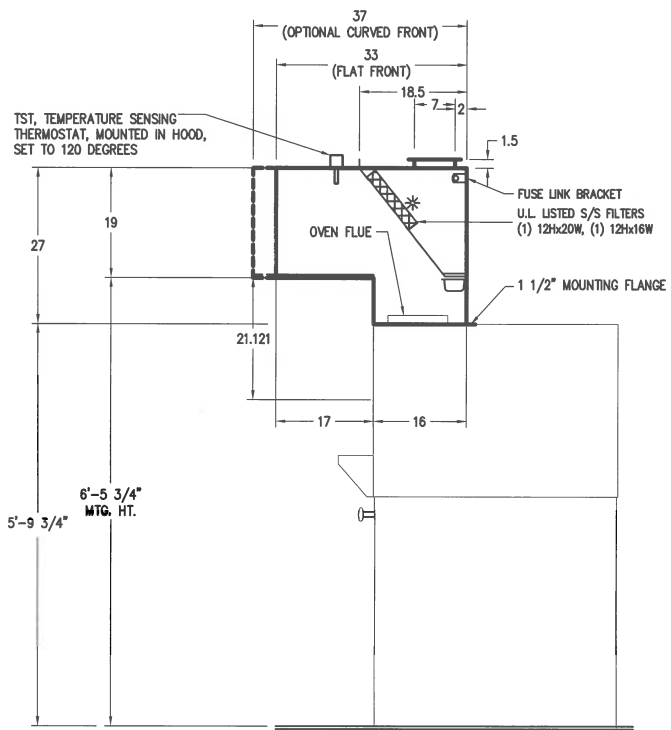
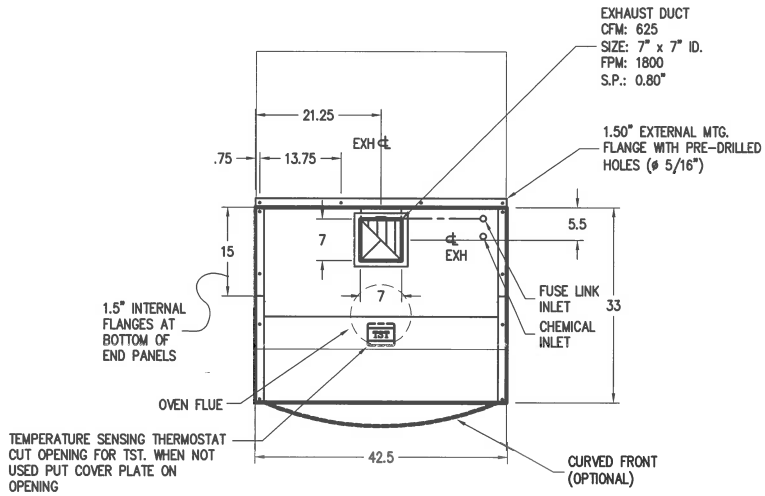



### DISASSEMBLING THE APPLIANCE TO MOVE THROUGH A NARROW DOOR OR PASSAGEWAY

1. Disconnect utility connections at rear of Control Box as described.

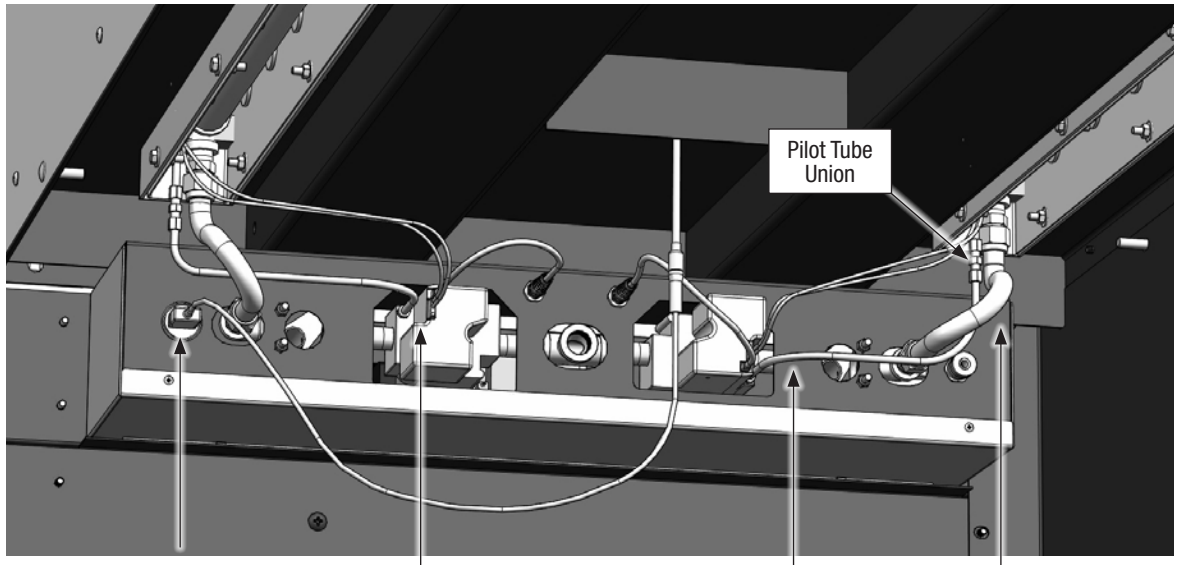

Unplug Thermocouple wire from Control Panel, coil it and tape it under the oven to prevent damage while moving the main body.

**DO NOT REMOVE THERMOCOUPLE FROM OVEN FLOOR.**

Unplug Igniter Wires (L&R) from the Gas Valves/Control Panel, coil them up and tuck them into the Burner.

Disconnect Pilot Tubes at the Gas Valves and at the Union (L&R). Carefully bend the remaining length of tube from the Pilot up inside the Burner Assembly to protect it.

Remove the Flexible Gas Connectors from Burners (L&R).

2. To begin disassembly of the Mantle, remove the 4 screws from the Mantle Faceplate Cover.

3. Remove 3 Bolts across the oven face and 2 Carriage Bolts on either end that hold the Mantle in place, and remove the mantle. It may be necessary to cut the silicone at the joint between the Mantle and the oven.

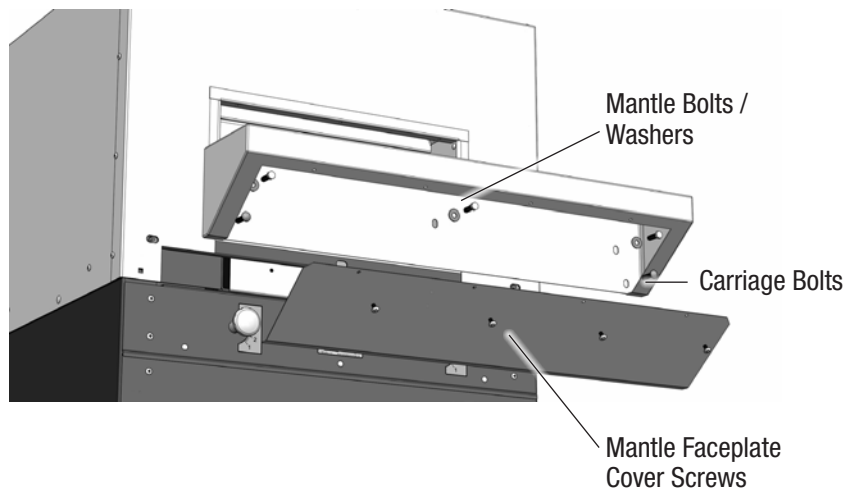



4. Remove the 4 1/4-20 screws securing the Control Box and slide it out from the oven.

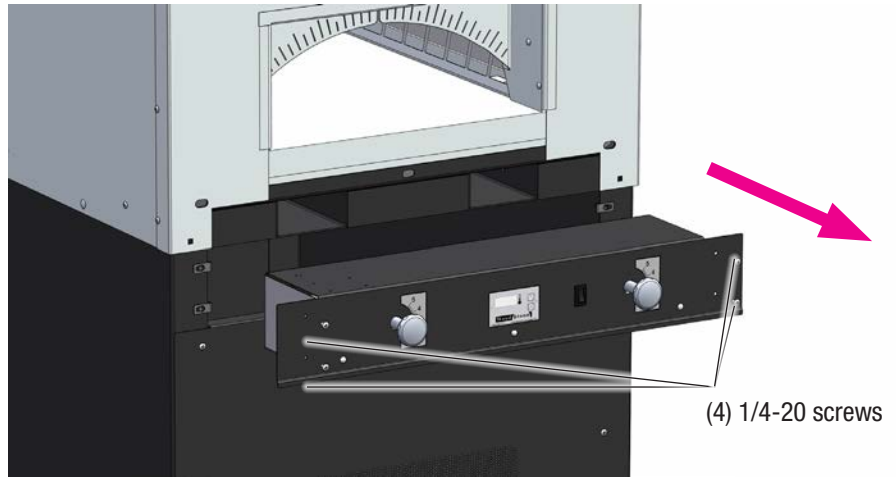

5. Using the upper forklift pockets, support the oven with a forklift or other suitable device. Remove the bolts that attach the oven body to the stand. Lift the oven off of the stand and place it on blocks as shown in Step 1 in LIFTING THE OVEN section. Follow the instructions in the LIFTING THE OVEN section for tilting and moving the main body. Disassemble the stand if necessary. Follow the assembly instructions in the ASSEMBLY section to reassemble the oven.

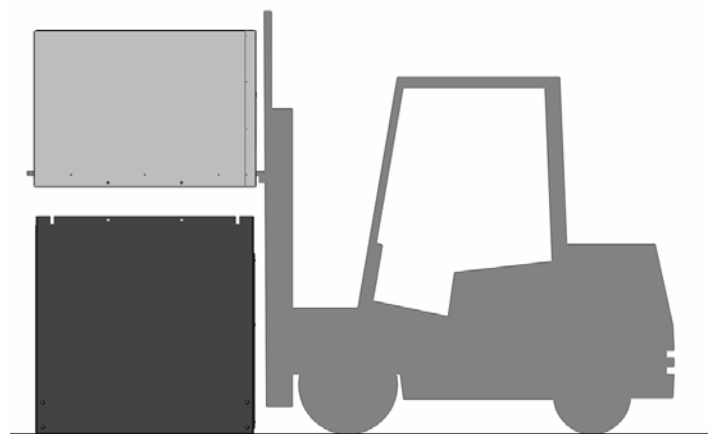



### MOVING A DISASSEMBLED BISTRO OVEN THROUGH A NARROW DOOR OR PASSAGEWAY USING THE OPTIONAL LIFTING SYSTEM

An optional Lifting System is available from Wood Stone to facilitate tipping the oven body onto its back and lifting it. When turned on its back, the upper oven portion of Bistro 4343, 4355 and 4836 (REC-(8, 9, 11)) will be approximately 32 inches wide. This will allow for easier access through small passages.

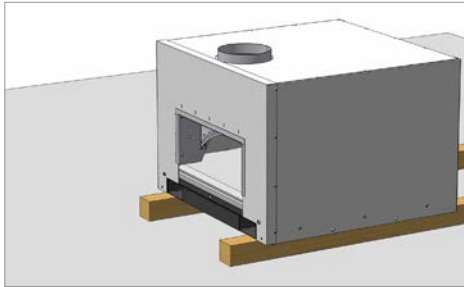

1. Use a forklift or other suitable lifting means to set the oven body onto 4x4" blocks oriented as shown. Refer to DISASSEMBLY section of manual for disassembly instructions.

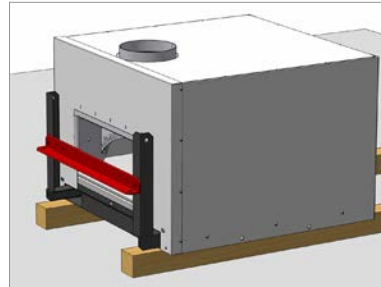

4. Attach the Crosspiece using the hardware provided. See drawing below for placement of bolts on various models.  
Tighten all Pickeye and Crosspiece bolts.

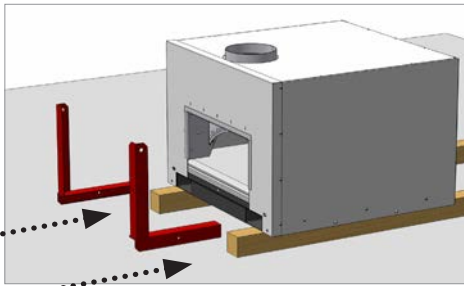

2. Insert the left & right Pickeye Inserts of the Lifting System into the forklift pockets from the oven front.

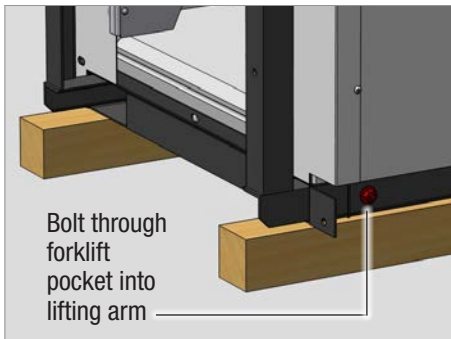
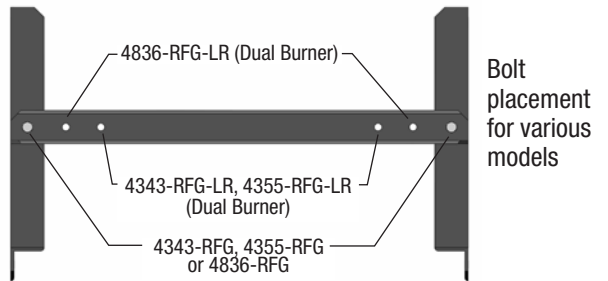

Oven cut-away view showing right Pickeye Insert of Lifting System in forklift pocket

Bolt through forklift pocket into lifting arm

3. Loosely bolt each Pickeye Insert to the forklift pocket as shown in the cut-away view to above.

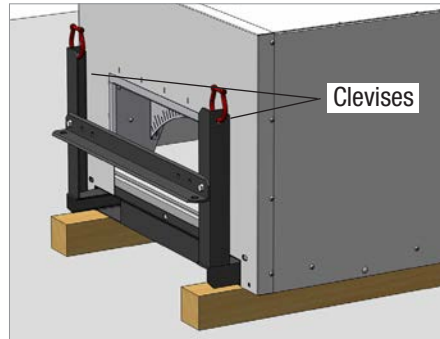

Clevises

5. Install a clevis in the Top Hole of each Pickeye Insert of the Lifting System.

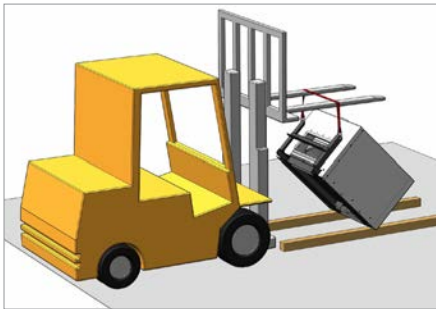

6. Attach strap to the clevises at the top of each Pickeye Insert. Using an appropriate hoist or lift, tilt the oven on its back, onto 4x4" blocks.

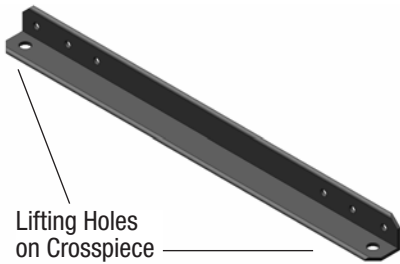

7. Change the position of the clevises to the Lifting Holes on the Crosspiece and attach straps.



8. Lift the oven straight up and position pallet jack under the oven.  
Lower the oven, on its back, onto the pallet jack.

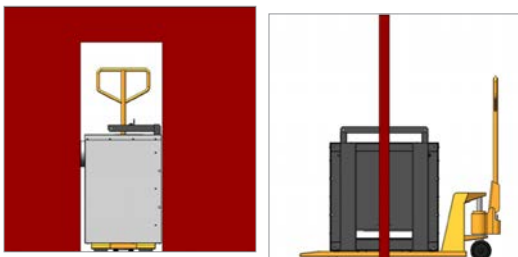

9. The oven can now be moved through a narrow doorway or passageway.

**DANGER:** Never attempt to move the oven in this manner on any type of incline or sloped floor.



10. Once the oven is on the other side of the passageway, attach strap to the clevises at the Lifting Holes on the Crosspiece and, with a gantry crane, lift the oven straight up.  
Remove pallet jack.  
Lower the oven onto 4x4" blocks.



11. Move strap to the clevises at the top of the Pickeye Inserts and tilt the oven down onto the 4x4" blocks positioned as shown.  
Remove the Lifting System from the oven.



12. Run straps through forklift pockets and up to a Spreader Bar.  
**Note:** The Spreader Bar must be wide enough so the straps clear the body of the oven.  
Lift the oven straight up and remove the 4x4" blocks.



13. Maneuver oven stand into position under the oven using pallet jack.  
Lower oven and secure oven to stand with bolts.





With the exception of the temporary Shipping Panel, all parts shown below, including the Rear Panel, **MUST** be installed to ensure the safe and proper operation of the oven.

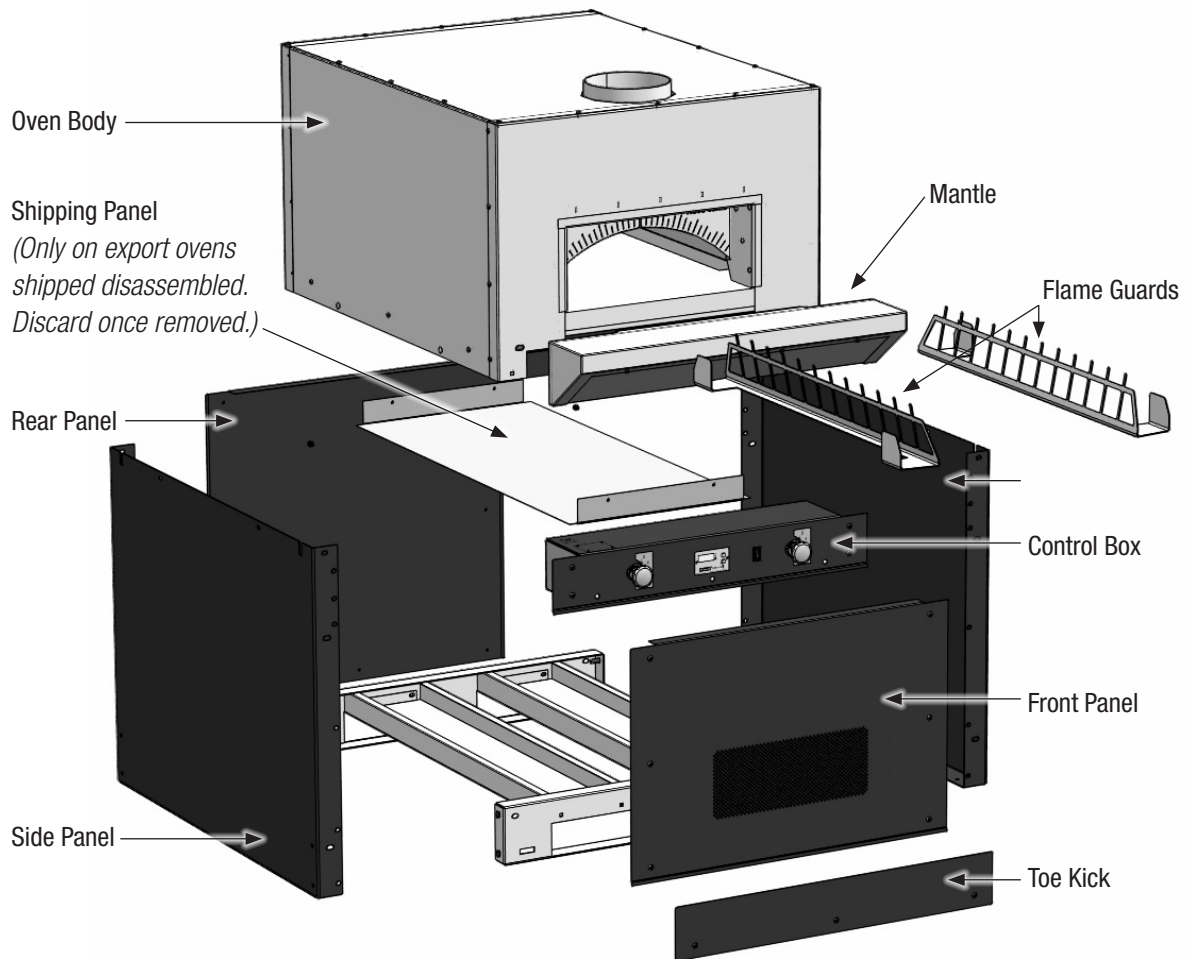



Follow these instructions only if the oven was shipped disassembled, or disassembled to move through a narrow door or passageway.

The oven must be installed on a flat level surface. The weight of the oven is carried by the full perimeter of the oven stand. If it is necessary to shim the oven for leveling purposes, it is critical that the shim material be metal, and that the shims are installed in such a way that the full perimeter of the stand is solidly supported. Any gaps created by shimming between the oven and the floor must be sealed for proper ventilation. Failure to solidly support the full perimeter of the oven stand can result in costly damage to the oven and will void the warranty.

The floor design and construction must be adequate to handle the weight of the oven. Please see [woodstone-corp.com/installation\\_footprints.htm](http://woodstone-corp.com/installation_footprints.htm) for floor loading information.

1. Lay out pieces.

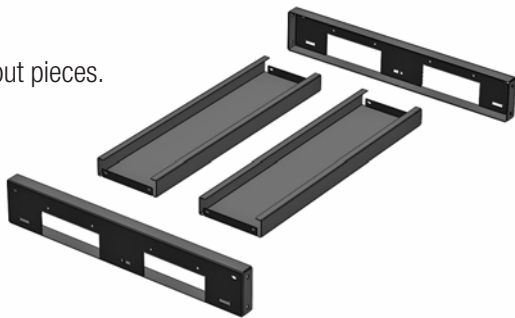

2. Use the 3/8" x 1" carriage bolts to assemble the stand. Be sure to use the washers provided and to tighten nuts and bolts securely.

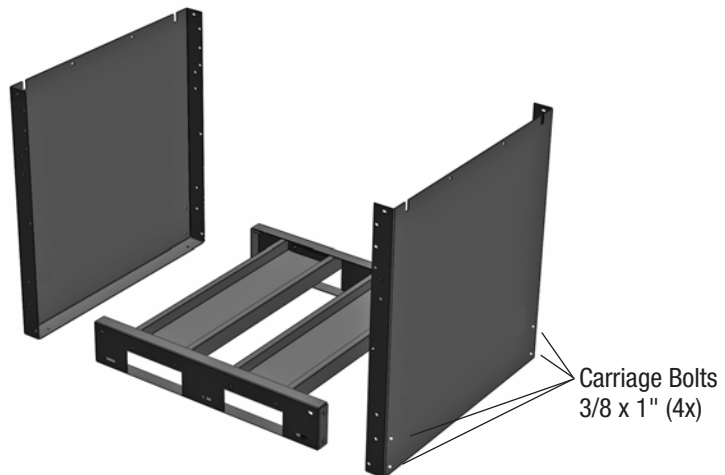

3. Using a forklift or other suitable lifting device, carefully lower the body of the oven on to the stand so that the bolt holes line up. While supporting the oven with the lift, install the 3/8-inch x 1-inch carriage bolts. Use the washers provided and tighten all nuts securely. Be sure to use the forklift pockets when lifting the body of the oven.

**NOTE:** Oven ships with temporary 'X' braces across the front and back. Leave the 'X' bracing in place until the rear panel is installed.

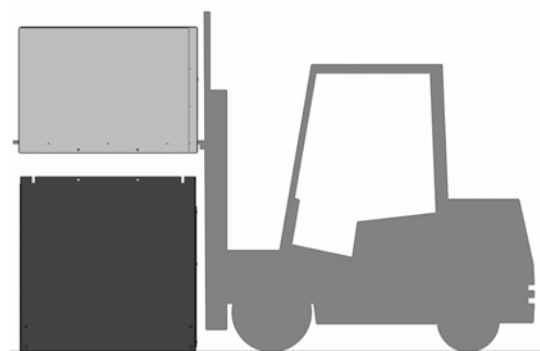

4. After the oven body is bolted to the stand, the oven can be moved into place with a pallet jack using the LOWER forklift pockets. If the oven is to be installed against a wall, leave access to the back of the oven until the assembly is completed. See CAUTIONS on next page.



**CAUTION:** The oven is very top-heavy. IF THE OVEN TIPS IT CAN CAUSE SEVERE INJURY OR DEATH! The oven should only be moved using a pallet jack on a LEVEL FLOOR. Do not attempt to move the oven with a hand truck. If the oven must be moved over an inclined surface, a forklift or other suitable means should be employed. If the installer does not have the equipment or experience required to move the oven safely, we recommend you secure the services of a qualified rigging company.

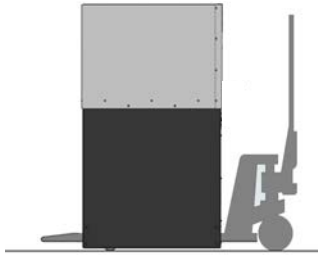

The oven should only be moved using a pallet jack on a LEVEL FLOOR. If the oven must be moved over an inclined surface, a forklift or other suitable means should be employed.

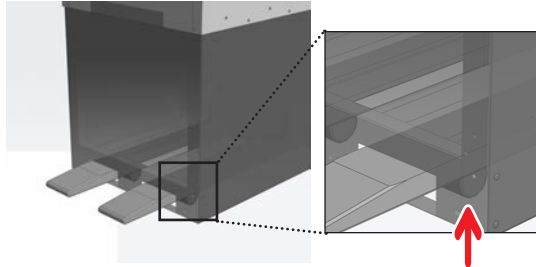

Make sure the pallet jack wheels do not contact the underside of the fork pocket when lifting to avoid damaging the stand.



Never attempt to use a hand truck to move the oven.

- Attach the Control Box to the oven using (4) 1/4-20 screws. The Control Box should be oriented so the Flame Height Control Knob is on the left side.

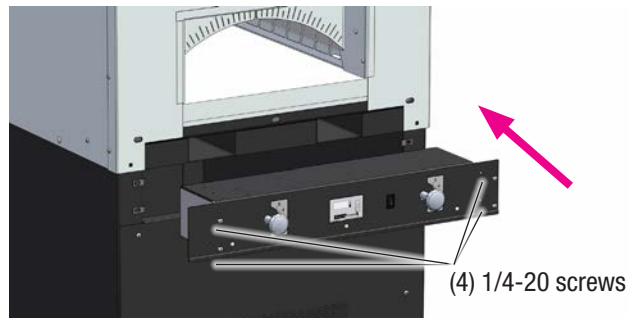

- Connect Burner Assembly components and Thermocouple at the rear of the Control Box.

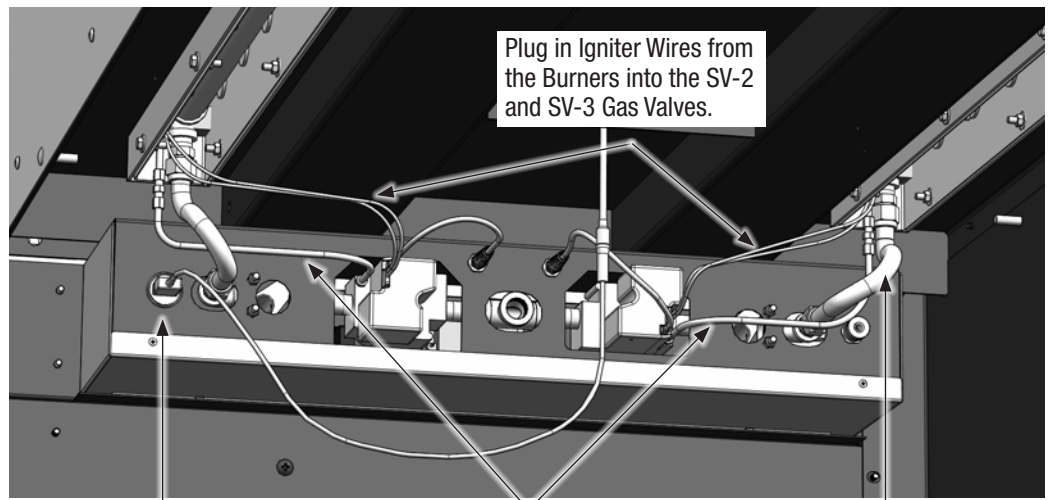

Plug in Thermocouple Wire here.

Attach flexible Pilot Tubes between the SV-2 & SV-3 Gas Valves and left & right Burners. Tighten the fitting firmly.

Use Flexible Gas Pipe provided to connect the Burner, left and right.



7. Install the Mantle. Fasten using 3 bolts / washers and 2 carriage bolts (see illustration).

If the oven has been supplied with a granite mantle, affix the granite slab to the mounting bracket using a generous amount of the adhesive provided.

8. Place the Mantle Faceplate Cover over the open area under the top of the Mantle. Install the cover plate using the 4 screws provided.

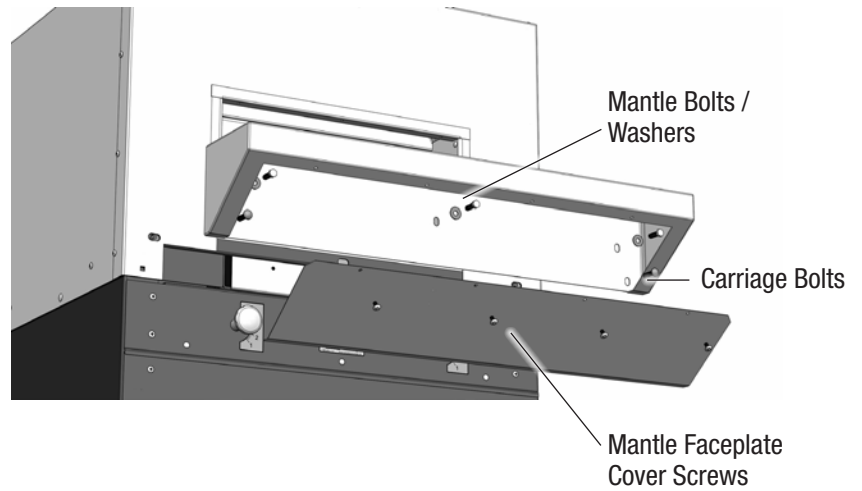

9. Run a bead of high temperature silicone (provided) along visible joints where the mantle and the oven intersect—in the front and down both sides of the oven (right side not shown).

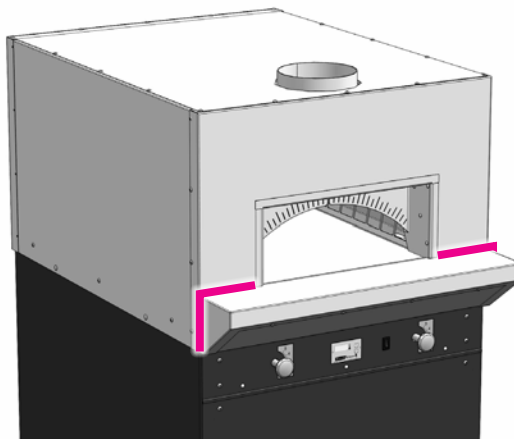

10. Reinstall the Burner Guards. The lower tab of the guard fits into the front of the burner opening.

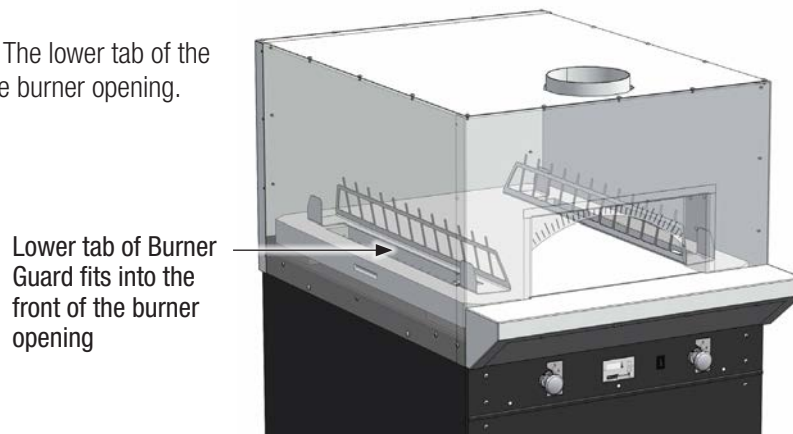

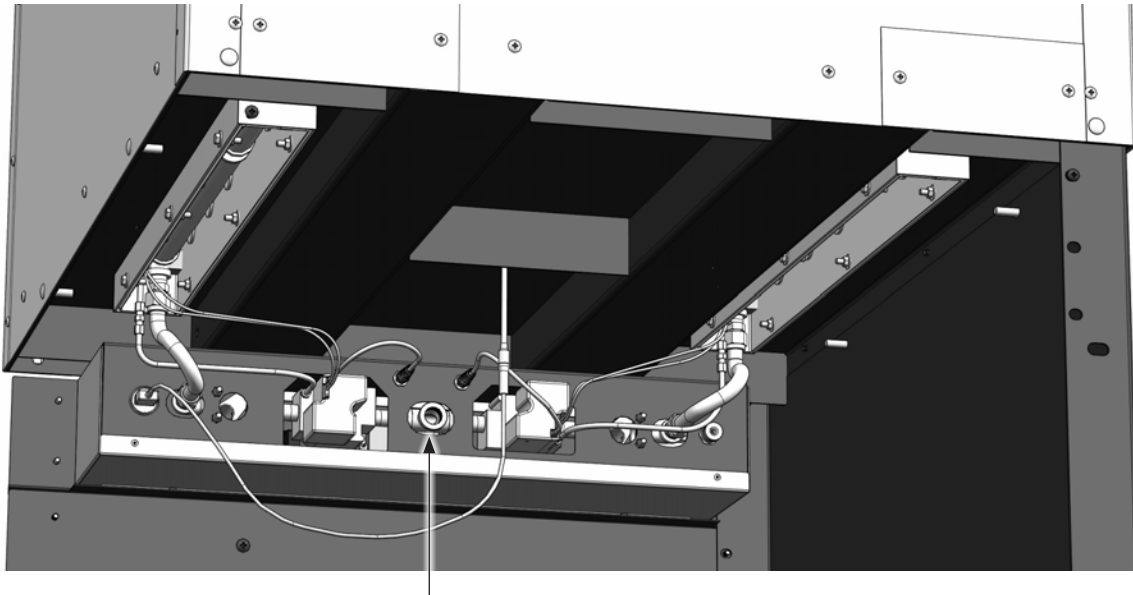

Connect the incoming gas supply to the 3/4-inch FNPT gas inlet.

For non-plug models, make the electrical connection to the terminals in Junction Box. Correct voltage is specified on the Junction Box and the Equipment Data Plate.

11. Make gas connection at the rear of the Control Box. Gas and electrical connections must comply with all relevant national and local codes, and in a manner acceptable to the authority having jurisdiction.

Knockouts are provided on the rear of the oven stand for the incoming gas and electrical supplies. If necessary, holes may be drilled in a side panel for the incoming gas and electrical. Gas and electrical supplies should be routed in such a way that they do not interfere with the removal of the oven burner, or block the access to the space under the oven for service. The area beneath the burner needs to be kept clear of conduit and piping to allow for removal of the burner for service. **The rear panel must be installed!** A 3/4-inch full-flow gas shut-off valve should be installed on the gas supply near the oven in such a way that it is readily accessible.

**This appliance must be electrically grounded in accordance with local code, or in the absence of local code, with the national electrical code, ANSI/NFPA 70, or the Canadian Electrical Code, CSA C22.2, as applicable.**

An electrical diagram is provided inside the bottom cover of the Control Box, and at the end of this manual.



The installation must conform with local codes, or in the absence of local codes with the National Fuel Gas Code, ANSI 223.1 or Natural Gas Installation Code, CAN/CGA-B149.1, as applicable.

1. The appliance and its individual shutoff valve (supplied by others) must be disconnected from the gas supply piping system during any pressure testing of that system at test pressures in excess of 1/2 psi (3.45 kPa).
2. The appliance must be isolated from the gas supply piping system by closing its individual manual shutoff valve (supplied by others) during any pressure testing of the gas supply system at test pressures equal to or less than 1/2 psi (3.45 kPa).

The incoming gas supply pressure must not exceed 1/2 psi (14 inches W.C.). If the incoming gas pressure exceeds 1/2 psi, an external gas regulator must be installed in the supply line. If the supply pressure is less than 1/2 psi, no external regulator is required.

The installer should bleed any air out of the gas line supplying the oven. All gas connections and fittings on the oven should be leak checked with an approved soap solution.

### CHECKING THE BURNER MANIFOLD PRESSURES

The burner manifold pressures have been set at the factory. However, they should be checked by the installer. The pressures should be checked at the outlet tap on each Honeywell gas valve, located on the back of the control box. Once the manometer is connected, turn the oven on and use the knob on the oven to adjust the flame to its maximum height. Then check the manifold pressure.

#### All Models

Natural Gas (NG): 4.5" W.C.

Propane (LG): 10" W.C.

This information can also be found on the data plate located beneath the oven.

### FRONT AND REAR PANEL INSTALLATION

Install the rear panel, front panel, and toe kick using the 1/4-20 screws provided. The front panel on the oven must not be covered, so as to allow access for service to the oven components. The oven should be bolted to the floor using the holes provided at the base of the stand.

**NOTE:** Rear panel must be installed for the proper functioning of the oven.



### INSTALLATION OF OPTIONAL STORAGE BOX

1. Install Toe Kick (w/ perforations) using (3) provided 1/4-20 screws **(a)**.
2. Slide Storage Box into front of oven, flush to side panel flanges and Toe Kick. Fasten using (4) provided 1/4-20 screws **(b)**.
3. Tuck Storage Box Connector under control panel and over top of Storage Box. Fasten using (2) provided 1/4-20 screws **(c)**.

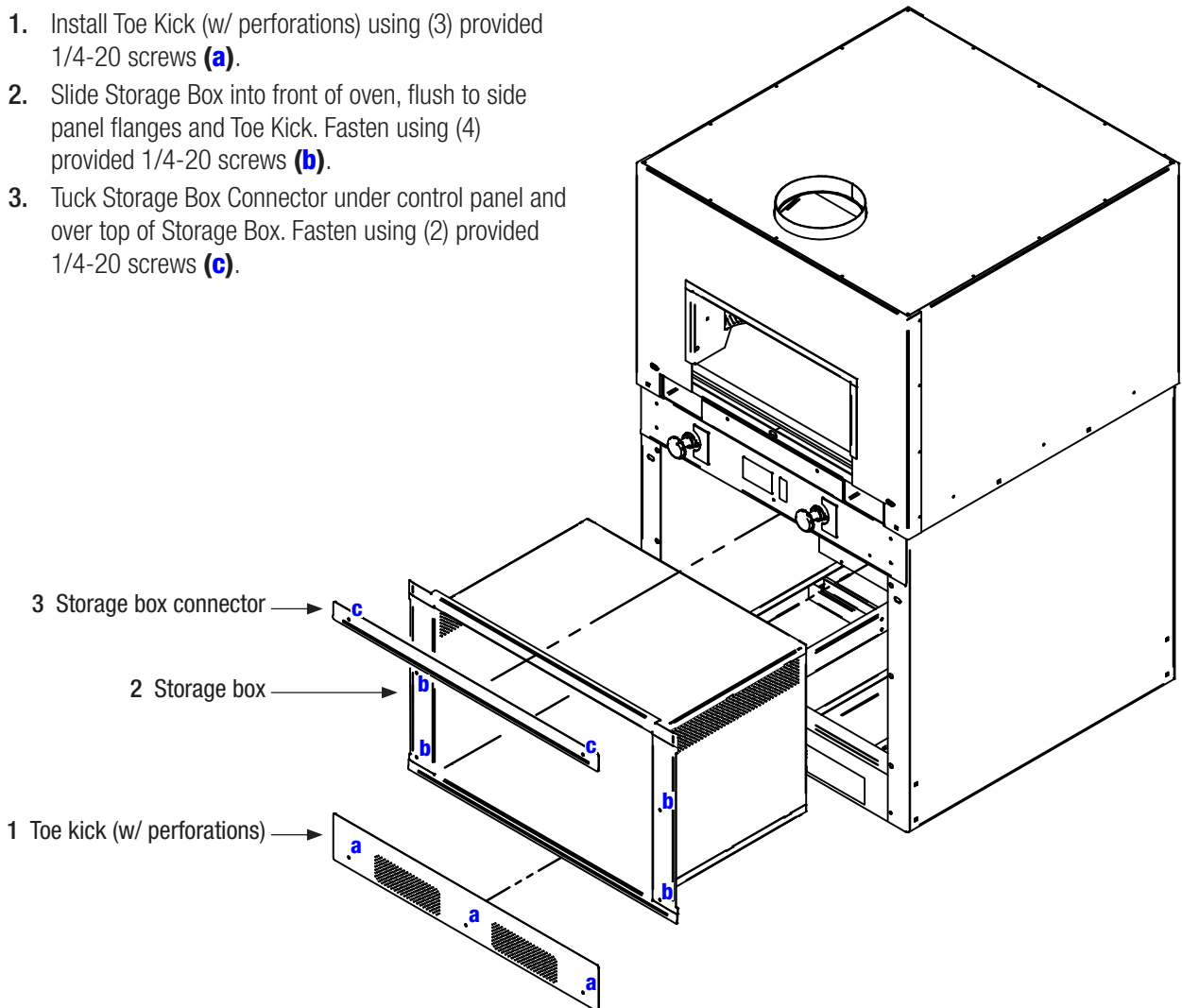

### CONTROLLER FUNCTIONS

**Hearth Temperature**  
The floor (hearth) temperature will be displayed when the oven is turned on. Sensor is embedded 1" below hearth surface. Display will read "LO" when the temperature is below 100 °F.



**Temperature units**  
Press and hold to switch between Fahrenheit and Celsius.

**ON/OFF button**  
Press to turn display on and off.

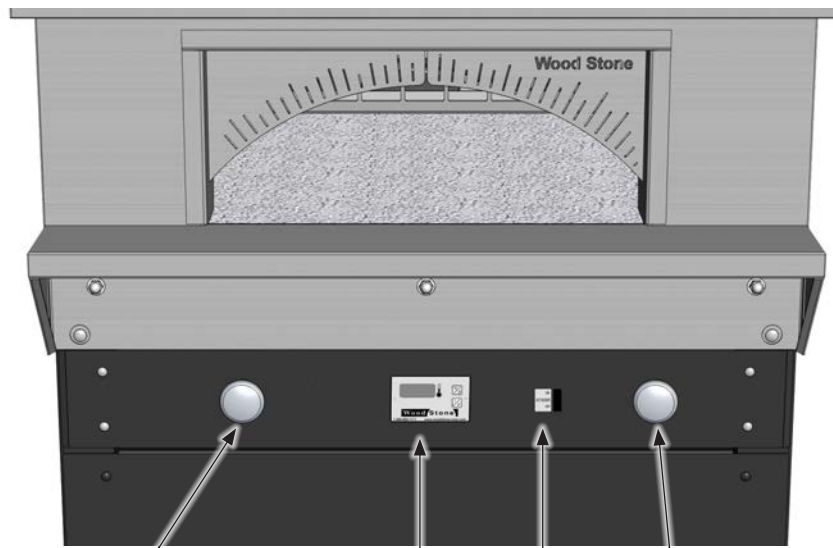

**Flame Height Control Knob (left)**  
Use these knobs to raise/lower the flame to control the oven temperature. Dual burner models have (2) knobs which are linked together (see Burner Disable Switch at right).

**Controller**

**Flame Height Control Knob (right)**  
**Burner Disable Switch**  
Use this switch to disable one of the burners (specify which burner will be disabled at time of order).





### INITIAL OVEN START-UP FOR DUAL BURNER BISTRO MODELS

#### FIRST DAY

1. Make sure main gas supply is on (valve parallel with gas line).
2. Push I/O button on controller. It may take a while for the gas to purge all the air from the gas lines. (Verify both burners light. If only one is lite, check that the Burner Disable switch on the front panel is in the ON position.)
3. Once the burners ignite, make sure the flames are at their lowest setting and allow the oven to operate at this setting for about 8 hours, or until the temperature reaches 450 °F.

#### SECOND DAY

1. Turn the radiant flames all the way up until the desired cooking temperature is achieved.

#### IMPORTANT NOTE ON DUAL BURNER MODELS:

The (2) flame height control knobs are linked together for ease of use. Turning either knob will raise or lower both flames. If you wish to unlink the knobs for individual control of each burner, please contact the factory for instructions.

#### NIGHT HEAT RETENTION DOOR

The night door should be removed whenever the oven is turned ON.

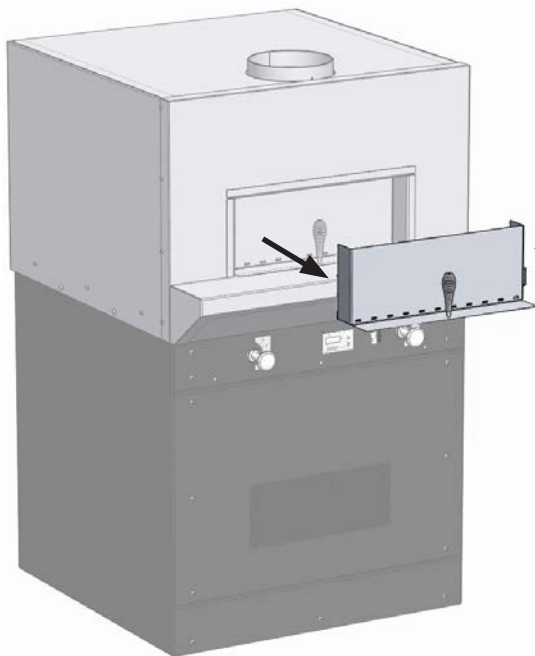

Night Heat Retention Door

**NOTE:** Never operate this appliance with the (optional) stainless steel Night Heat Retention Door in place. This option is for heat retention only, and should only be used when the appliance is turned off.



### GENERAL DAILY OVEN OPERATION

The oven floor temperature is displayed on the controller readout.

### END OF THE DAY

Push I/O button on the controller. All gas will go off, even the pilots. When the oven is turned off, use the Night Heat Retention Door to help retain heat in the oven. The night door is placed into the oven doorway.

### BEGINNING OF THE DAY

Make sure the Night Heat Retention door is removed. Push I/O button and turn the radiant flames to their highest setting. Oven should reach the desired cooking temperature within 2 hours. Use the Flame Height Control Knob to control the amount of heat in the oven.

See [woodstone-corp.com](http://woodstone-corp.com) for detailed information on cooking in your Wood Stone oven.

### CLEANING THE OVEN

1. As needed (twice per hour), use the floor brush to sweep stray food debris to the doorway, where it can be easily removed with a dough cutter or spatula.
2. As needed, swab the deck using a damp (not wet) rag wrapped around the floor brush. Take care not to brush debris into the radiant flame burners.

**DO NOT POUR OR SPRAY LIQUIDS ONTO THE OVEN DECK OR INTO THE OVEN INTERIOR  
AS THIS CAN DAMAGE THE CERAMIC AND WILL VOID THE WARRANTY.**



### OVEN INTERIOR

Wood Stone recommends the use of long-handled brushes for sweeping up surface debris that will accumulate on the floor of the oven during use. Use a natural fiber brush—always brushing away from the radiant burner wells. For deeper cleaning, use a brass bristled brush. The oven floor can be then cleaned with a damp rag wrapped around the brass bristled brush head. (Wood Stone offers an assortment of oven brushes available through your dealer. Specification sheets may be viewed on the Wood Stone website under Tools & Accessories.)

**TAKE CARE NOT TO BRUSH DEBRIS INTO THE RADIANT FLAME BURNERS.**

### OVEN EXTERIOR (DOORWAY AND MANTLE)

All exterior stainless steel surfaces should be cleaned as necessary using an approved mild detergent, hot water and a soft cloth or sponge. Stubborn residues may be removed using a non-metallic scouring pad. When scouring stainless steel surfaces, scrub with the grain of the metal to prevent scratching.

**DO NOT POUR OR SPRAY LIQUIDS ONTO THE OVEN DECK OR INTO THE OVEN INTERIOR**

**AS THIS CAN DAMAGE THE CERAMIC AND WILL VOID THE WARRANTY.**

**IMPORTANT: DO NOT USE EXCESSIVE AMOUNTS OF LIQUID WHEN WIPING  
ON OR AROUND THE OVEN CONTROL BOX.**

### THERMAL CLEANING

If a Wood Stone gas-fired oven is operated at low temperatures (below 525 °F), you may notice a buildup on the oven floor. Note that this floor buildup may be perceived as the floor flaking away. If you operate the oven below 450 °F you may also notice some buildup on the interior walls and/or ceiling of the oven. To remove any buildup that has accumulated inside of the oven, simply turn the radiant flame to its highest setting. Monitor the floor temperature displayed on the controller. When the floor reaches 650 °F, lower the flame slightly so as to maintain the oven floor temperature near 650 °F for about an hour. Heavy accumulations may require more time. Heavy accumulations on the floor may require some additional scraping with a utility peel or a floor scraping tool. Once the oven appears clean, allow the oven to return to normal operating temperatures and continue normal operation.



PROBLEM	CAUSE/SOLUTION
Controller will not turn on	<ol style="list-style-type: none"> <li>Incoming power to oven turned off. Check circuit breaker for circuit supplying the oven. Check that any wall switches external to the oven that control oven power are turned on. Check that any interlocks external to the oven are turned on.</li> <li>If controller still does not turn on, please contact Wood Stone for assistance.</li> </ol>
Flame does not light	<ol style="list-style-type: none"> <li>Check gas is turned on to the oven, and gas shut-off valve is turned all the way on.</li> <li>Debris in burner. Burner may require cleaning. Contact Wood Stone for assistance.</li> <li>Damaged igniter or gas valve. Contact Wood Stone for assistance.</li> </ol> <p>If the oven is being started for the first time:</p> <ul style="list-style-type: none"> <li>- Has all air been bled from the gas line?</li> <li>- Is the switch on the SV-2 and SV-3 valve in the ON position?</li> </ul> <p><b>NOTE:</b> Valves are locate on the back of the control box, beneath the oven.</p>
Flame cuts out	<ol style="list-style-type: none"> <li>Debris in burner.</li> <li>Oven is being run with the night door in place. Night Heat Retention Door must be removed whenever the oven is turned on.</li> <li>Wind blowing into the oven, or other venting issues.</li> </ol>
Display reads "OPEN"	<ol style="list-style-type: none"> <li>Thermocouple is not plugged into control box.</li> <li>Damaged thermocouple. Contact Wood Stone for assistance.</li> </ol>

Please contact Wood Stone at 1-800-988-8103 should service be necessary, or if you have any questions about your oven. Our service hours are 8am to 4:30pm Pacific Standard Time. Follow the recorded instructions for Emergency Service if you require assistance during non-business hours. A Wood Stone technician will promptly respond to your call.



### DUAL BURNER BISTRO - ALL MODELS 120 VAC ELECTRICAL DIAGRAM

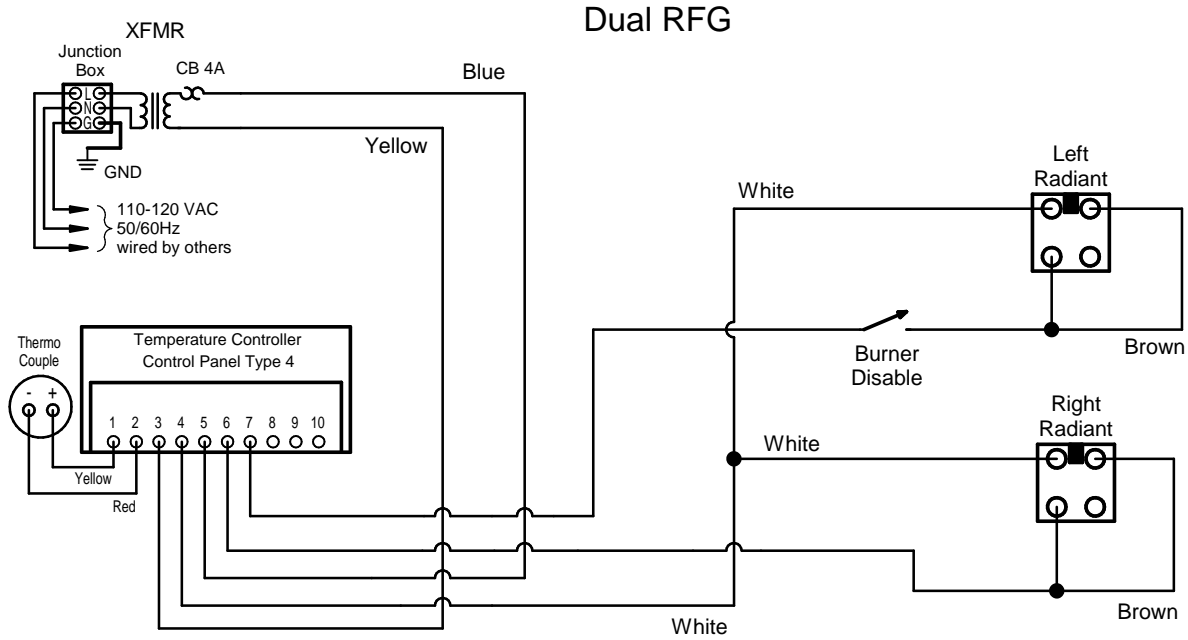

Bellingham, WA +1(360)650-1111 [www.woodstone-corp.com](http://www.woodstone-corp.com)

DIAG #: WD075 Rev. 1  
DATE: 11/12/2014



An ongoing program of product improvement may require us to change specifications without notice. **WS-BL-RFG-LR, Revised April 2015.**  
Doc no: M0028.02

**wood stone corporation**  
1801 w. bakerview rd.  
bellingham, wa 98226 usa

tf. 800.988.8103  
t. 360.650.1111  
f. 360.650.1166

[info@woodstone-corp.com](mailto:info@woodstone-corp.com) or visit [woodstone-corp.com](http://woodstone-corp.com)



### DUAL BURNER BISTRO - ALL MODELS 240 VAC ELECTRICAL DIAGRAM

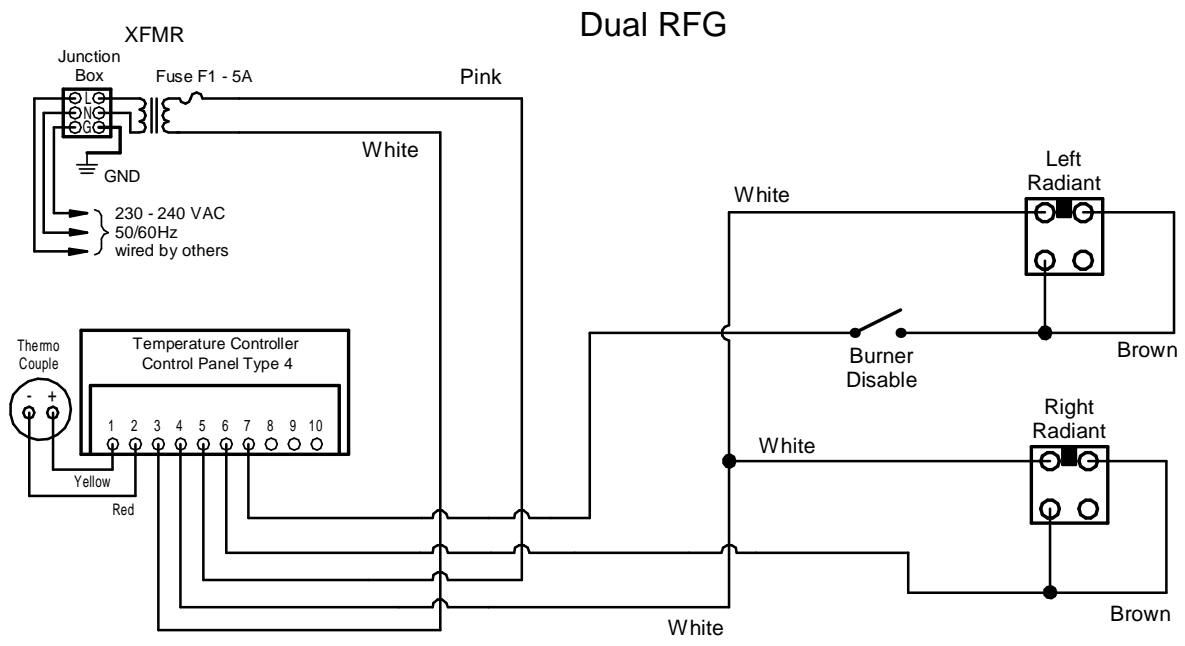

Bellingham, WA +1(360)650-1111 [www.woodstone-corp.com](http://www.woodstone-corp.com)

**DIAG #:** WD078 Rev. 0  
**DATE:** 7/17/2014



An ongoing program of product improvement may require us to change specifications without notice. **WS-BL-RFG-LR, Revised April 2015.**  
**Doc no: M0028.02**

**wood stone corporation** tf. 800.988.8103  
1801 w. bakerview rd. t. 360.650.1111  
bellingham, wa 98226 usa f. 360.650.1166  
**info@woodstone-corp.com** or visit **woodstone-corp.com**



### INTERLOCK OF OVEN CONTROL TO AN EXHAUST FAN

This connection is intended to interrupt power to the oven until the fan is turned on.

*Wired by others*

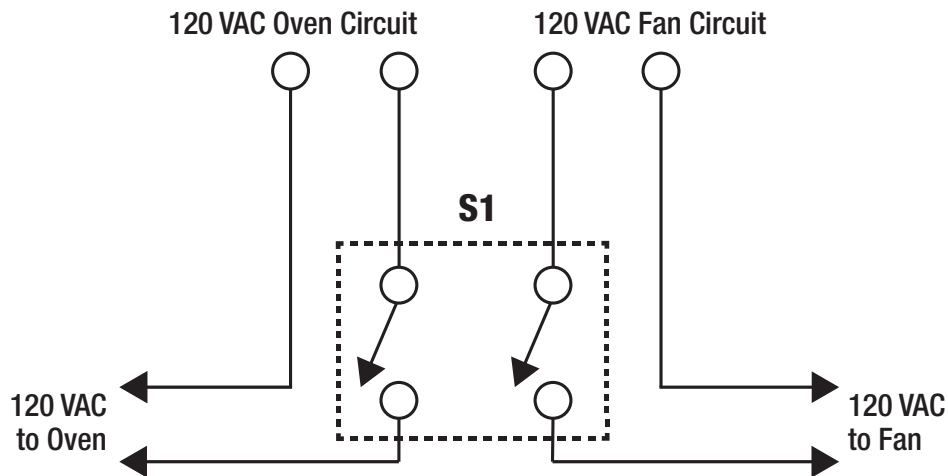

S1 is a Double Pole, Single Throw (DPST) switch provided by others.

S1 is a double pole, single throw switch (provided by others) that interrupts in-coming power to both the oven and the fan. The intent is to prevent the operation of the oven's gas burner in the event the fan is shut off.

Any interruption of the power to the oven will cause the oven (including all burners and pilots) to shut off, and it will be necessary to restart the oven by pressing the start switch once power is restored.

For additional interlock options, see the Wood Stone Interlock Options supplement in the Manuals section on the website, [woodstone-corp.com](http://woodstone-corp.com), or contact Wood Stone for additional information.



### ALL WARRANTY SERVICE MUST BE PRE-APPROVED BY WOOD STONE

Wood Stone warrants its equipment to the original purchaser against defects in material or manufacture for a period of one year from the original date of purchase, subject to the following exclusions and limitations.

Please contact the factory first at 1.800.988.8103 or 1.360.650.1111, seven days a week. Our normal business hours are 8am to 4:30pm PST Monday–Friday. If calling during non-business hours, follow the recorded instructions for emergency service and a Wood Stone technician will get back to you promptly.

#### EXCLUSIONS

The warranties provided by Wood Stone do not apply in the following instances:

1. In the event that the equipment is improperly installed. Proper installation is the responsibility of the installer; proper installation procedures are prescribed by the Wood Stone Installation and Operation Manual.
2. In the event the equipment is improperly or inadequately maintained. Proper maintenance is the responsibility of the user; proper maintenance procedures are prescribed in the Wood Stone Installation and Operation Manual. Burner problems resulting from debris or ash in the burner well will not be covered by the warranty. Call with questions regarding maintenance frequency.
3. In the event that the failure or malfunction of the appliance or any part thereof is caused by abnormal or improper use or is otherwise not attributable to defect in material or manufacture.
4. In the event that the appliance, by whatever cause, has been materially altered from the condition in which it left the factory.
5. In the event that the rating plate has been removed, altered or obliterated.
6. On parts that would be normally worn or replaced under normal conditions.
7. Normal cracking due to expansion and contraction stress relief in the ceramic firebox.
8. In wood-fired equipment configurations, in the event that pressed log products of any type have been burned in the equipment.
9. In coal-fired oven configurations, in the event any type of coal other than anthracite coal fuel has been used.
10. Damage resulting from the use of chemical cleaning products in the oven, as well as any damage from liquids or chemicals, including water, being poured or sprayed into the oven.

If any oral statements have been made regarding this appliance, such statements do not constitute warranties and are not part of the contract of sale. This Limited Warranty constitutes the complete, final and exclusive statement with regard to warranties.

**THIS LIMITED WARRANTY IS EXCLUSIVE AND IN LIEU OF ALL OTHER WARRANTIES WHETHER WRITTEN, ORAL OR IMPLIED, INCLUDING, BUT NOT LIMITED TO, ANY WARRANTY OF MERCHANTABILITY OR FITNESS FOR PARTICULAR PURPOSE OR WARRANTY AGAINST LATENT DEFECTS.**

#### LIMITATIONS OF LIABILITY

In the event of warranty claim or otherwise, the sole obligation of Wood Stone shall be the repair and/or replacement, at the option of Wood Stone, of the appliance or component or part thereof. Such repair or replacement shall be at the expense of Wood Stone with the exception of travel over 100 miles or two hours, overtime, and holiday charges which shall be at the expense of the purchaser. Any repair or replacement under this warranty does not constitute an extension of the original warranty for any period of the appliance or for any component or part thereof. Parts to be replaced under this warranty will be repaired or replaced at the option of Wood Stone with new or functionally operative parts. The liability of Wood Stone on any claim of any kind, including claims based on warranty, expressed or implied, contract, negligence, strict liability or any other theories shall be solely and exclusively the repair or replacement of the product as stated herein, and such liability shall not include, and purchaser specifically renounces any rights to recover, special, incidental, consequential or other damages of any kind whatsoever, including, but not limited to, injuries to persons or damage to property, loss of profits or anticipated profits, or loss of use of the product.

#### TO SECURE WARRANTY SERVICE

If you claim a defect covered by this Limited Warranty, contact:

Wood Stone Corporation, Attn: Service Department, 1801 W. Bakerview Rd., Bellingham, WA 98226 USA  
Phone 1.800.988.8103 or 1.360.650.1111



An ongoing program of product improvement may require us to change specifications without notice. **WS-BL-RFG-LR, Revised April 2015.**  
Doc no: M0028.02

**wood stone corporation**  
1801 w. bakerview rd.  
bellingham, wa 98226 usa

tf. 800.988.8103  
t. 360.650.1111  
f. 360.650.1166

**info@woodstone-corp.com** or visit **woodstone-corp.com**