

## Introduction

### Features and Functions

The CLW-DIM1 (-DIM1) is a stand-alone wall box dimmer that can also act as a Cresnet® device that reports to a Crestron® control processor. The CLW-DIM1 has two preset lighting levels that can be adjusted (refer to note below). The CLW-DIM1 also includes two isolated, non-polarized Cresnet wires (plus a ground wire) for connecting to the Cresnet network over a twisted pair wire with shield.

**NOTE:** The two preset levels are noted as Preset 1-High and Preset 1- Low. “Preset 1-High” is usually used for turning lights on to full brightness while preset “Preset 1-Low” is usually used for turning the lights off. Although “Preset 1-High” and “Preset 1-Low” are usually used for “On” and “Off” respectively, the light level for each preset can be customized by the user. Refer to “Operating Button and Switch” on page 5 for more information on customizing light levels.

The CLW-DIM1 features a three-position mode selection switch. Refer to “Operating Button and Switch” on page 5 for more information. In the absence of Cresnet communications, the dimmer can still be used to control lighting.

The CLW-DIMS1 (-DIMS1) is similar to the -DIM1 with the added capability of working with a slave unit (CLW-SLVD1) in a multi-switch / single circuit application.

The CLW-SLVD1 (-SLVD1) is a slave unit that when used in conjunction with the -DIMS1 acts as an additional dimmer control point in a multi-dimmer / single circuit application. It does not connect to a Cresnet system and cannot be used without a -DIMS1. The -SLVD1 does not have a mode selection switch and is not programmable. It emulates the operation of the -DIMS1 to which it is connected.

The -DIM1, -DIMS1, and -SLVD1 are available in white, almond, and black. White units are designated by part numbers ending in “W”. Almond units are designated by part numbers ending in “A”. Black units are designated by part numbers ending in “B”. Each dimmer can be covered with a decorative faceplate (not supplied).

## Specifications

Following are specifications for the -DIM1, -DIMS1, and -SLVD1.

### CLW-DIM1, CLW-DIMS1, & CLS-SLVD1 Specifications

SPECIFICATION	DETAILS
Power Requirements	Line Power, 120 VAC, 60 Hz
Default Net ID	-DIM1: 80 -DIMS1: 81
Switch Type	Dimmer
Load Type	Incandescent, Tungsten-Halogen, Magnetic Low Voltage
2-Series Control System Update File <sup>1,2</sup>	Version 3.117 or later
Load Ratings <sup>3</sup>	
Incandescent/Tungsten Halogen	-DIM1: 1000W -DIMS1: 1000W -SLVD1: N/A
Magnetic Low Voltage <sup>4</sup>	-DIM1: 1000VA/750W -DIMS1: 1000VA/750W -SLVD1: N/A
Operating Temperature and Humidity	32°F to 104°F (0°C to 40°C) 10 to 90% Relative Humidity (Non-Condensing)
Dimensions and Weight	-DIM1 and -DIMS1: Height: 4.13 in (10.48 cm) Width: 2.38 in (6.03 cm) Depth: 1.91 in (4.85 cm) Weight: 4.9 oz (0.67 kg) -SLVD1: Height: 4.13 in (10.48 cm) Width: 1.75 in (4.45 cm) Depth: 1.91 in (4.85 cm) Weight: 3.6 oz (0.50 kg)

1. The latest versions can be obtained from the Downloads | Software Updates section of the Crestron website ([www.crestron.com](http://www.crestron.com)). Refer to NOTE below.
2. Crestron 2-Series control systems include the AV2 and PRO2. Consult the latest Crestron Product Catalog for a complete list of 2-Series control systems.
3. Refer to Derating Charts for Multigang Installations on page 3.
4. VA ratings are for input power to the transformer. If you do not know the input power requirement of the transformer, use the bulb’s wattage rating to determine proper rating.

**NOTE:** Crestron software and any files on the website are for Authorized Crestron dealers and Crestron Authorized Independent Programmers (CAIP) only. New users may be required to register to obtain access to certain areas of the site (including the FTP site).

## Physical Description

The -DIM1 and -DIMS1 contain one large pushbutton, a light emitting diode (LED) with software adjustable brightness\*, and a three-position slider-switch, shown after this paragraph. The -SLVD1 is similar to the -DIM1 and -DIMS1 but does not have the slider-switch. Line voltage connections are made at the rear of the dimmer. Three Class 2 low voltage wires, located on the front of the switch provide a Cresnet connection to a control system. The wires are routed to the bottom of the unit for placement outside of the wall box.

\* LED brightness can only be adjusted through Crestron programming software.

*CLW-DIM1/-DIMS1 (L) and CLW-SLVD1 (R) shown in white*



*Physical view of CLW-DIM1/-DIMS1 (clockwise from top; Top, Side, and Front)*

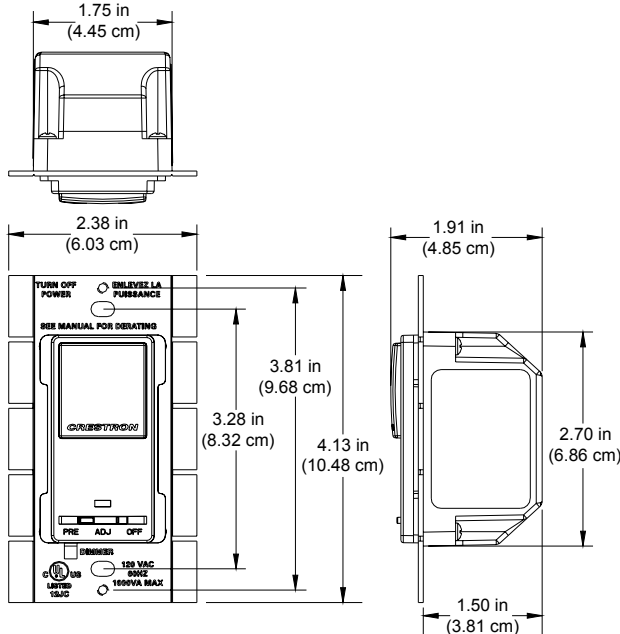

*Physical view of CLW-SLVD1 (clockwise from top; Top, Side, and Front)*

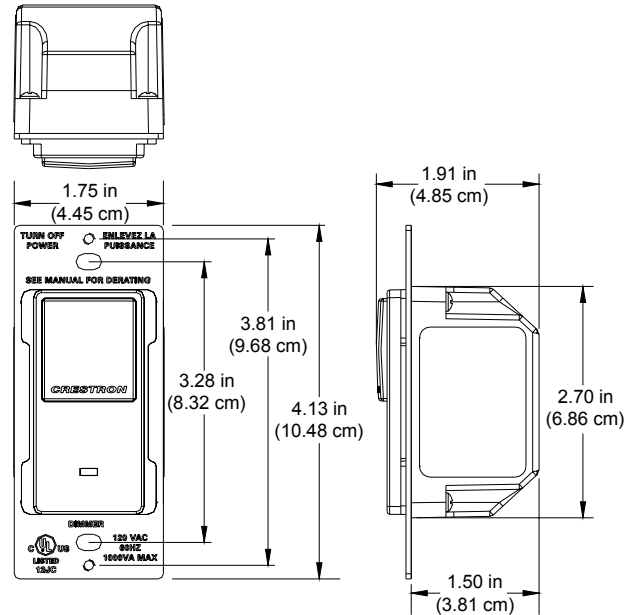

The -DIM1, -DIMS1, and -SLVD1 mount in a standard wallbox and are covered using a decorative faceplate (not included).

## Industry Compliance

This unit has been manufactured to comply with UL's Standards for Safety in Canada and the United States. Formal approval is pending.

## Important Notes

**Read before installation.**

- Codes: Install in accordance with all local and national electrical codes.

Alternate wiring methods may be used for the Class 2 wiring connection. The 2002 National Electrical Code (Article 725-55) prohibits Class 2 conductors of the -DIM1, -DIMS1, and -SLVD1 to occupy the same outlet box as the power conductors. The exception is Part D of Section 725.55 of the 2002 National Electrical Code, which allows a device's power conductors to be installed near (0.25 inch minimum spacing) associated Class 2 conductors in the same outlet box. Consult the 2002 National Electrical Code Handbook and your local electrical inspector before proceeding.

Do not use the supplied butt-splice connectors if the Class 2 conductors are to be installed in the wallbox with the power conductors. Use approved connectors (supplied by others) to make Class 2 connections inside the wallbox.

- **CAUTION:** TO REDUCE THE RISK OF OVERHEATING AND POSSIBLE DAMAGE TO OTHER EQUIPMENT, DO NOT INSTALL TO CONTROL A RECEPTACLE OR A MOTOR OPERATED APPLIANCE (i.e. BATH FAN).
- **Wiring:** Use copper wire only. For supply connections, use wires rated for at least 75°C.
- **Lamp Type:** The -DIM1, -DIMS1, and -SLVD1 are designed for use with permanently installed incandescent, magnetic low voltage, or tungsten-halogen only.
- **Temperature:** The -DIM1, -DIMS1, and -SLVD1 are designed to be used where temperatures are between 32° to 104°F (0° to 40°C).
- **Wallboxes:** Devices mount in standard wallboxes. For easy installation, Crestron recommends using 3 ½” deep wallboxes. Several devices can be installed in one wall box (multigang). This requires the removal of side sections (refer to diagram on page 3) and the derating of the dimming device. For a smooth appearance, one-piece multigang faceplates (not supplied) can be installed.
- **Other Switch Devices:** Mechanical 3- or 4-way switches will not work with the -DIM1, -DIMS1, or -SLVD1.
- **Spacing:** If mounting one device above another, leave at least 4 ½” vertical space between them.
- **Low Voltage Applications:** Use with core and coil (magnetic) low voltage transformers only. Do not use any solid-state electronic low voltage transformers.

Operation of a low voltage circuit with all lamps inoperative or removed may result in current flow in excess of normal levels. To avoid transformer overheating and premature transformer failure, Crestron recommends the following:

- Do not operate low voltage circuits without operative lamps in place.
- Replace burned-out lamps as quickly as possible.
- Use transformers that incorporate thermal protection or fuse transformer primary windings to prevent transformer failure due to overcurrent.

## Multigang Installations

In multigang installations, several controls are grouped horizontally in one wallbox. For a smooth appearance, one-piece multigang faceplates (not supplied) can be installed.

1. When combining controls in a wallbox, remove inner side sections prior to wiring (refer to the following figure).

### Inner Sections of Multiganged Switches

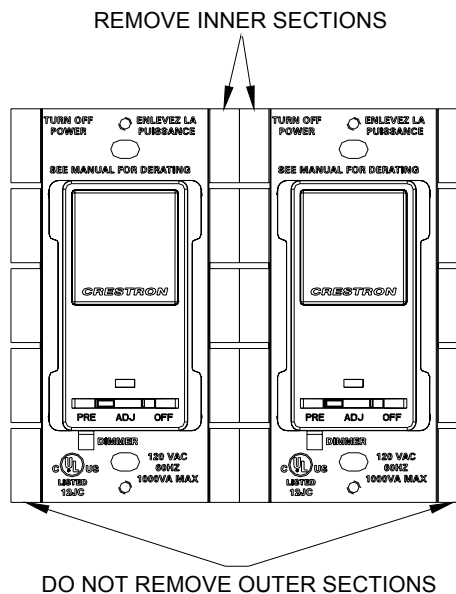

The load capacity must also be derated. The following charts provide derating information for various applications.

### Derating Information for Incandescent and Tungsten Halogen Applications

Part Number	No Side Removed	One Side Removed	Two Sides Removed
-DIM1	1000W	600W	400W
-DIMS1	1000W	600W	400W
-SLVD1	No Derating Necessary		

### Derating Information for Magnetic Low Voltage Applications\*

Part Number	No Side Removed	One Side Removed	Two Sides Removed
-DIM1	1000VA/750W	600VA/450W	400VA/300W
-DIMS1	1000VA/750W	600VA/450W	400VA/300W
-SLVD1	No Derating Necessary		

\* VA ratings are for input power to the transformer. If you do not know the input power requirement of the transformer, use the bulb's wattage rating to determine proper rating.

2. To remove a side section, bend the side section back and forth with a pair of pliers until the section breaks off from the mounting plate. Use a file or sandpaper to remove any excess metal.

## Prewire for Master Application

Each device has two Class 2 low voltage wires (plus a ground wire) that provide a Cresnet connection over shielded twisted-pair to a Crestron control system. These wires are routed to the bottom of the device for connection outside of the wallbox. The low voltage wires are pulled from each device location to the Crestron control system or a Crestron connection block device. Use #22 AWG, twisted, shielded, 2-conductor wire. Wiring can be daisy chained, T-tapped, or home run back to the control system. Refer to the following wiring diagram.

### Wiring Diagram of CLW device to Cresnet

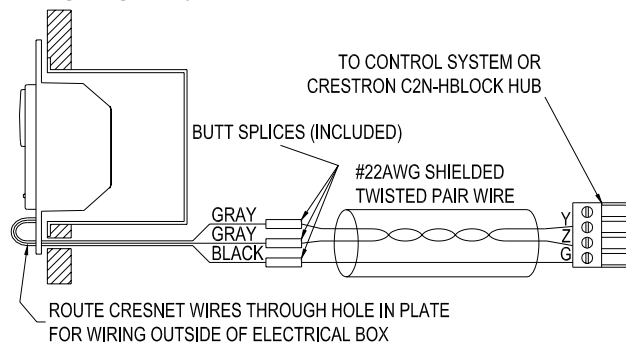

**NOTE:** The GRAY (Cresnet) wires are not polarized. These wires can be connected to either the Y or Z line on a Cresnet port.

**NOTE:** The BLACK wire (Cresnet ground) should not be grounded with the GREEN (Ground) wire on the -DIM1/-DIMS1.

**NOTE:** Crestron recommends using *Cresnet-DM* cable for connecting the -DIM1 and -DIMS1 to the Cresnet network.

## Installation

**NOTE:** The -DIMS1 must be installed in the same wallbox that contains the connections to the load.

**NOTE:** The -DIM1, -DIMS1, and -SLVD1 require a neutral wire for operation. If no neutral is present, contact a licensed electrician for installation or contact Crestron Customer Service for alternative wiring options.

**WARNING:** Turn off power at the circuit breaker. Installing with power on can result in serious personal injury and damage to the device.

**NOTE:** New installations should be checked for short circuits prior to installing the -DIM1, -DIMS1, or -SLVD1. With power off, close the circuit and restore power. If the lights do not work or a breaker trips, check and correct the wiring or fixture (if necessary). Install the -DIM1, -DIMS1, or -SLVD1 only when the short is no

longer present. **The warranty is void if the -DIM1, -DIMS1, or -SLVD1 is installed and operated with a shorted load.**

1. Turn power off at the circuit breaker.
2. If installing multiple dimmers (-DIM1 or -DIMS1), note the serial number on each device and make sure they are being installed in the proper location.
3. Pull Class 2 low voltage wires through a hole in the drywall located outside of the electrical box, to the Crestron control system or a Crestron connection block device. Leave wires outside of the wallbox for connection to the -DIM1 or -DIMS1.

**NOTE:** Alternate wiring methods may be used for the Class 2 wiring connection. Refer to section 725-55, Part D of the 2002 National Electric Code.

4. Wire the device for the appropriate application. Choose either “CLW-DIM1 / CLW-DIMS1 Wiring” or “CLW-DIMS1 with CLW-SLVD1 Wiring”, shown on this page and the following page.

**NOTE:** Alternative wiring methods can be obtained from the Dealer/Tech Resources | Design Center section of the Crestron website ([http://www.crestron.com/dealer-tech\\_resources/design\\_center/hot\\_design\\_tips\\_and\\_diagrams/tech\\_sales\\_tips/](http://www.crestron.com/dealer-tech_resources/design_center/hot_design_tips_and_diagrams/tech_sales_tips/)).

## CLW-DIM1 / CLW-DIMS1 Wiring

**NOTE:** The -DIM1 and -DIMS1 require a neutral wire for operation. If no neutral is present, contact a licensed electrician for installation or contact Crestron customer service for alternative wiring options.

The following wiring diagram illustrates installation of the -DIM1 or -DIMS1.

### Wiring Diagram for CLW-DIM1 (L) or CLW-DIMS1 (R)

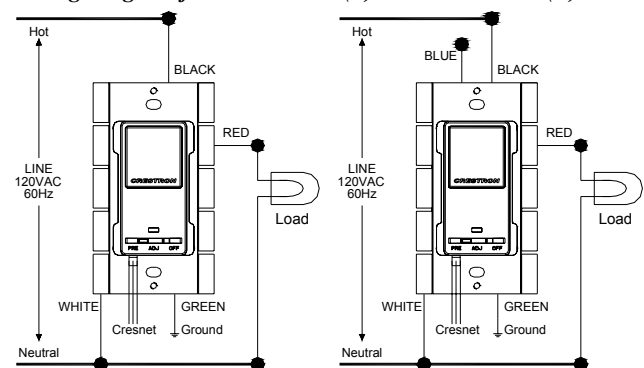

# CRESTRON® CLW-DIM1, DIMS1, & SLVD1(W/A/B)

**NOTE:** The RED (Load) and BLACK (Hot) wires are #14 AWG. The BLUE (Slave) and WHITE (Neutral) wires are #18 AWG. The GREEN (Ground) wire is #16 AWG. The GRAY (Cresnet) wires are #22 AWG. The BLACK wire (Cresnet ground) paired with the GRAY (Cresnet) wires is #22 AWG.

## CLW-DIMS1 with CLW-SLVD1 Wiring

**NOTE:** The -DIMS1 must be installed in the same wallbox that contains the connections to the load.

The following wiring diagram illustrates installation of the -DIMS1 with multiple -SLVD1s.

*Wiring Diagram of CLW-DIMS1 with multiple CLW-SLVD1s*

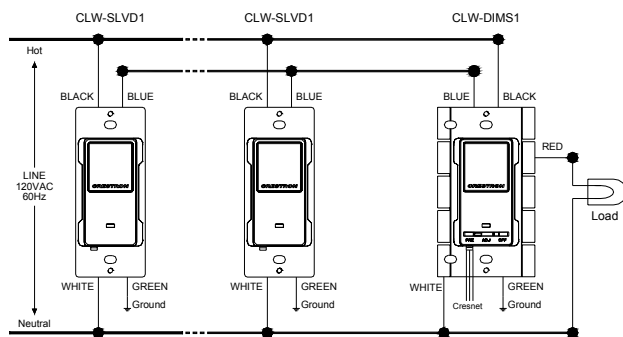

**NOTE:** Do not connect the BLUE (Slave) wire to the Black (Hot) or RED (Load) wires.

**NOTE:** The RED (Load) and BLACK (Hot) wires are #14 AWG. The BLUE (Slave) and WHITE (Neutral) wires are #18 AWG. The GREEN (Ground) wire is #16 AWG. The GRAY (Cresnet) wires are #22 AWG. The BLACK wire (Cresnet ground) paired with the GRAY (Cresnet) wires is #22 AWG.

**NOTE:** If a -DIMS1 is installed without a -SLVD1, the BLUE lead (Slave) should be capped.

5. Splice the gray wires of the -DIM1 or -DIMS1 to the Class 2 low voltage wires connected to the Crestron control system or a Crestron connection block device. Push the wires and the splices into a hole in the drywall to provide the necessary separation.
6. Push all Class 1 power wires back into the wallbox and fasten the device to the wallbox with the provided screws.
7. Attach decorative faceplate.
8. Restore power.

## Operating Button and Switch

The -DIM1, -DIMS1, and -SLVD1 have one large pushbutton. The -DIM1 and -DIMS1 also have a three-position mode selection switch. The function of the pushbutton is determined by the position of the mode selection switch. Refer to the following diagram.

**NOTE:** The -SLVD1 does not have a mode selection switch. It will act in the same mode as the -DIMS1.

*Buttons of CLW-DIM1, -DIMS1, and -SLVD1*

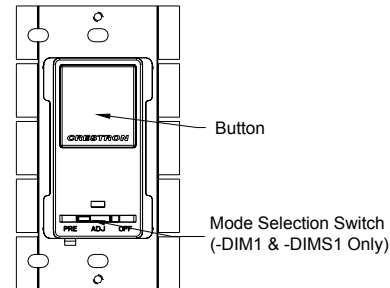

### OFF

When the mode selection switch is in the “OFF” position, the pushbutton will not have any function and the load is disconnected from the power source. This **must** be used when changing light bulbs to ensure that the load is fully disconnected from power.

### ADJ

When the mode selection switch is in the “ADJ” position, the pushbutton is used to switch between the “Preset 1-High” and “Preset 1-Low” presets (typically “On” and “Off”) as well as adjust the lighting level. Tap the pushbutton to fade up or down to either of the two preset lighting levels. Tap the pushbutton while the lighting level is fading to jump directly to the preset lighting level without fading. (i.e., tapping while the lighting level is fading up will jump to the “Preset 1-High” level without fading, tapping while the lighting level is fading down will jump to the “Preset 1-Low” level without fading). While the light is off, double-tap the pushbutton to jump directly to the “Preset 1-High” lighting level without fading.

The lighting level can be adjusted by pressing and holding the pushbutton. After a ½ second, the lighting level will ramp up or down. The lighting level will stop at maximum brightness (100%) if the lighting level was ramping up or minimum brightness (0%) if the lighting level was ramping down. To continue ramping the lighting level in the opposite direction, release the pushbutton, then press and hold the pushbutton again.

When the desired lighting level is reached, release the pushbutton.

If the lighting level is to be stored as a preset, move the mode selection switch to the PRE position. Press and hold the pushbutton until the LED flashes.

## PRE

**NOTE:** Before storing a preset, the lighting must be adjusted to the desired level while in the ADJ mode.

When the switch is in the PRE position, it is in the preset mode and can be used to recall and/or store preset lighting levels. The pushbutton is used to recall and/or store the “Preset 1-High” and “Preset 1-Low” presets. Pressing and releasing the pushbutton will fade to the preset lighting level over a preset amount of time\*. Tapping the pushbutton while the light is fading will cause the light level to “jump” directly to the preset without fading. Pressing and holding the pushbutton until the LED flashes will store the current lighting level.

\* The preset fade time can only be adjusted through Crestron programming software.

To store preset values for “Preset 1-High” and “Preset 1-Low”; while in the PRE mode, recall the lighting level to be changed. Switch to the ADJ mode and adjust the lighting to the desired level. Move the mode selection switch to PRE. Press and hold the pushbutton until the LED flashes to store the new preset value.

**NOTE:** If a new preset value for “Preset 1-High” is lower than the stored value for “Preset 1-Low”, the previously stored value for “Preset 1-Low” becomes “Preset 1-High”. Similarly, if a new preset value for “Preset 1-Low” is higher than the value stored for “Preset 1-High”, the previously stored value for “Preset 1-High” becomes “Preset 1-Low”.

**NOTE:** The default preset light values for each preset are:

- Preset 1-High: 100%
- Preset 1-Low: 0%

**NOTE:** The device may be warm to the touch during operation. This is normal.

## Restoring Default Settings

To restore the dimmer’s default settings for lighting levels, preset fade time (two seconds), and ramp time (five seconds), move the mode selection switch to the PRE position. While holding the pushbutton, move the mode selection switch to the ADJ position and back to the PRE position. Release the pushbutton. The LED will flash to confirm that the default values have been restored.

## Return and Warranty Policies

### Merchandise Returns / Repair Service

1. No merchandise may be returned for credit, exchange, or service without prior authorization from CRESTRON. To obtain warranty service for CRESTRON products, contact the factory and request an RMA (Return Merchandise Authorization) number. Enclose a note specifying the nature of the problem, name and phone number of contact person, RMA number, and return address.
2. Products may be returned for credit, exchange, or service with a CRESTRON Return Merchandise Authorization (RMA) number. Authorized returns must be shipped freight prepaid to CRESTRON, 6 Volvo Drive, Rockleigh, N.J, or its authorized subsidiaries, with RMA number clearly marked on the outside of all cartons. Shipments arriving freight collect or without an RMA number shall be subject to refusal. CRESTRON reserves the right in its sole and absolute discretion to charge a 15% restocking fee, plus shipping costs, on any products returned with an RMA.
3. Return freight charges following repair of items under warranty shall be paid by CRESTRON, shipping by standard ground carrier. In the event repairs are found to be non-warranty, return freight costs shall be paid by the purchaser.

### CRESTRON Limited Warranty

CRESTRON ELECTRONICS, Inc. warrants its products to be free from manufacturing defects in materials and workmanship under normal use for a period of three (3) years from the date of purchase from CRESTRON, with the following exceptions: disk drives and any other moving or rotating mechanical parts, pan/tilt heads and power supplies are covered for a period of one (1) year; touchscreen display and overlay components are covered for 90 days; batteries and incandescent lamps are not covered.

This warranty extends to products purchased directly from CRESTRON or an authorized CRESTRON dealer. Purchasers should inquire of the dealer regarding the nature and extent of the dealer’s warranty, if any.

CRESTRON shall not be liable to honor the terms of this warranty if the product has been used in any application other than that for which it was intended, or if it has been subjected to misuse, accidental damage, modification, or improper installation procedures. Furthermore, this warranty does not cover any product that has had the serial number altered, defaced, or removed.

This warranty shall be the sole and exclusive remedy to the original purchaser. In no event shall CRESTRON be liable for incidental or consequential damages of any kind (property or economic damages inclusive) arising from the sale or use of this equipment. CRESTRON is not liable for any claim made by a third party or made by the purchaser for a third party.

CRESTRON shall, at its option, repair or replace any product found defective, without charge for parts or labor. Repaired or replaced equipment and parts supplied under this warranty shall be covered only by the unexpired portion of the warranty.

Except as expressly set forth in this warranty, CRESTRON makes no other warranties, expressed or implied, nor authorizes any other party to offer any warranty, including any implied warranties of merchantability or fitness for a particular purpose. Any implied warranties that may be imposed by law are limited to the terms of this limited warranty. This warranty statement supercedes all previous warranties.

#### Trademark Information

All brand names, product names, and trademarks are the sole property of their respective owners. Windows is a registered trademark of Microsoft Corporation. Windows95/98/Me/XP and WindowsNT/2000 are trademarks of Microsoft Corporation.