

# PollCat NetLink-VIP & NLJ-VIP

---

Pollable Call Accounting Terminals



## User's Guide





## Warnings and Cautions: INSTALLATION INSTRUCTIONS



### **SECURE RACKING**

---

If Secure Racked units are installed in a closed or multi-unit rack assembly, they may require further evaluation by Certification Agencies. The following items must be considered.

1. The ambient within the rack may be greater than room ambient. Installation should be such that the amount of air flow required for safe operation is not compromised. The maximum temperature for the equipment in this environment is 45°C. Consideration should be given to the maximum rated ambient.
2. Installation should be such that a hazardous stability condition is not achieved due to uneven loading.

### **INPUT SUPPLY**

---

1. Check nameplate ratings to assure there is no overloading of supply circuits that could have an effect on overcurrent protection and supply wiring.
2. When installing 48 VDC rated equipment, it must be installed only per the following conditions:
  - A. Connect the equipment to a 48 VDC supply source that is electrically isolated from the alternating current source. The 48 VDC source is to be connected to a 48 VDC SELV source.
  - B. Input wiring to terminal block must be routed and secured in such a manner that it is protected from damage and stress. Do not route wiring past sharp edges or moving parts.
  - C. A readily accessible disconnect device, with a 3 mm minimum contact gap, shall be incorporated in the fixed wiring.

### **GROUNDING**

---

Reliable earthing of this equipment must be maintained. Particular attention should be given to supply connections when connecting to power strips, rather than direct connections to the branch circuit.

### **No Serviceable Parts Inside; Authorized Service Personnel Only**

---

Do not attempt to repair or service this device yourself. Internal components must be serviced by authorized personnel only.

- **Shock Hazard - Do Not Enter**

### **Disconnect Power**

---

If any of the following events are noted, immediately disconnect the unit from the outlet and contact qualified service personnel:

1. If the power cord becomes frayed or damaged.
2. If liquid has been spilled into the device or if the device has been exposed to rain or water.

## **FCC Part 15 Regulation**

---

This equipment has been tested and found to comply with the limits for a Class A digital device, pursuant to part 15 of the FCC Rules. These limits are designed to provide reasonable protection against harmful interference when the equipment is operated in a commercial environment. This equipment generates, uses, and can radiate radio frequency energy and, if not installed and used in accordance with the instruction manual, may cause harmful interference to radio communications. Operation of this equipment in a residential area is likely to cause harmful interference in which case the user will be required to correct the interference at his own expense.

This device complies with part 15 of the FCC Rules. Operation is subject to the following two conditions: (1) This device may not cause harmful interference, and (2) this device must accept any interference received, including interference that may cause undesired operation

**WARNING: Changes or modifications to this unit not expressly approved by the party responsible for compliance could void the user's authority to operate the equipment**

## **Industry Canada**

---

This Class A digital apparatus complies with Canadian ICES-003.

Cet appareil numérique de la classe A est conforme à la norme NMB-003 du Canada.

This product meets the applicable Industry Canada technical specifications

The Ringer Equivalence Number is an indication of the maximum number of devices allowed to be connected to a telephone interface. The termination on an interface may consist of any combination of devices subject only to the requirement that the sum of the RENs of all the devices does not exceed five

# Table of Contents

---

<b>1. Introduction</b> .....	<b>1-1</b>
<b>2. Unit Description</b> .....	<b>2-1</b>
2.1. Front Panel Indicators .....	2-1
2.2. Back Panel .....	2-2
<b>3. Quick Start Guide</b> .....	<b>3-1</b>
3.1. Hardware Installation .....	3-1
3.1.1. Apply Power to the VIP .....	3-1
3.1.2. Connect your PC to the VIP .....	3-1
3.2. Communicating with the VIP .....	3-2
3.2.1. Access via Console Port or Modem .....	3-2
3.2.2. Access via Network .....	3-3
3.3. Connect your PBX to the VIP .....	3-4
<b>4. Hardware Installation</b> .....	<b>4-1</b>
4.1. Connect the VIP to Power Supply .....	4-1
4.1.1. AC Powered Units .....	4-1
4.1.2. DC Powered Units .....	4-2
4.2. Set-Up Switches .....	4-2
4.2.1. Default Baud Rate for Console Port (Sw1, Sw2, Sw3) .....	4-2
4.2.2. Default Baud Rate for PBX Port A, PBX Port B, and AUX Port (Sw4, Sw5) .....	4-3
4.2.3. Dialback Security Mode (Sw6) .....	4-3
4.2.4. Console Port Password (Sw7) .....	4-3
4.2.5. Power Up Default (Sw8) .....	4-4
4.3. Reset to Defaults .....	4-5
4.4. Connecting Cables and Phone Line .....	4-6
4.4.1. PBX Inputs A and B and AUX Port .....	4-7
4.4.2. Modem Port .....	4-7
4.4.3. Console Port .....	4-7
4.4.4. Network Port .....	4-7
<b>5. Configuration</b> .....	<b>5-1</b>
5.1. Access to the Command Mode .....	5-1
5.2. Menu System Conventions .....	5-3
5.2.1. Script Access to Menu Functions .....	5-3
5.3. Set System Parameters .....	5-4
5.4. Port Configuration .....	5-6
5.4.1. PBX Port A and PBX Port B .....	5-6
5.4.1.1. Field Suppression; The Lucent Switch Feature .....	5-8
5.4.2. Auxiliary Port Configuration .....	5-10
5.4.3. Console Port Configuration .....	5-12
5.4.4. Modem Port Configuration .....	5-15
5.4.4.1. Dialback Security .....	5-19
5.4.5. Network Port Configuration .....	5-20
5.4.5.1. The Email & Text Messaging Parameters Menu .....	5-23
5.4.5.2. The Ping Function .....	5-25
5.4.6. PBX IP Port Configuration .....	5-26
<b>6. Menu System Description</b> .....	<b>6-1</b>
6.1. Firmware Tree .....	6-1

---

- 7. Status Screens . . . . . 7-1**
  - 7.1. Buffer Status Screen . . . . . 7-2
  - 7.2. File List Screen . . . . . 7-3
  - 7.3. System Status Screen . . . . . 7-4
  - 7.4. Scheduled Action Status Screens . . . . . 7-5
  - 7.5. Dialback Security Status Screen . . . . . 7-6
  - 7.6. Data Filters & Alarms Status Screen. . . . . 7-7
  - 7.7. Alarm Condition Status Screen. . . . . 7-9
  - 7.8. PBX Inactivity Alarm Status Screens . . . . . 7-10
  - 7.9. 80% Full Alarm Status Screen . . . . . 7-12
  - 7.10. Input Contact Alarm Status Screen . . . . . 7-13
  - 7.11. Reason for Action Screen . . . . . 7-14
  - 7.12. PBX Port Status Screens . . . . . 7-15
  - 7.13. Auxiliary Port Status Screen . . . . . 7-16
  - 7.14. Console Port Status Screen . . . . . 7-17
  - 7.15. Modem Port Status Screen . . . . . 7-19
  - 7.16. Network Port Status Screen . . . . . 7-21
  - 7.17. Network Status Screen . . . . . 7-23
  - 7.18. PBX IP Port Status . . . . . 7-24
  - 7.19. Alarm Filter Clue Status Screens . . . . . 7-25
  
- 8. The Data Filters . . . . . 8-1**
  - 8.1. The Data Filter Configuration Menus . . . . . 8-1
  - 8.2. Defining the Data Filter Format . . . . . 8-2
  - 8.3. Defining Data Filter Clues . . . . . 8-4
  - 8.4. Logical and Relational Operators . . . . . 8-6
    - 8.4.1. Logical AND/OR Conditions . . . . . 8-7
      - 8.4.1.1. Logical AND Conditions . . . . . 8-7
      - 8.4.1.2. Logical OR Conditions . . . . . 8-7
    - 8.4.2. The "Contains String" Operator . . . . . 8-8
  - 8.5. Real-Time Variables . . . . . 8-8
  - 8.6. Assigning the Data Filter to a Port . . . . . 8-9
  - 8.7. Data Filter Definition Examples . . . . . 8-9
  
- 9. The Alarm Filters (Toll Fraud Detection) . . . . . 9-1**
  - 9.1. Common Types of Suspect Phone Activity. . . . . 9-1
  - 9.2. The Alarm Configuration Menu . . . . . 9-2
    - 9.2.1. Default Alarm Filter Actions . . . . . 9-2
  - 9.3. The Alarm Filter Configuration Menus. . . . . 9-5
  - 9.4. Defining the Alarm Filter Format . . . . . 9-6
  - 9.5. Defining the Alarm Filter Clues . . . . . 9-8
    - 9.5.1. Alarm Clue Definition . . . . . 9-9
    - 9.5.2. Editing and Deleting Clues . . . . . 9-10
  - 9.6. Logical and Relational Operators . . . . . 9-11
    - 9.6.1. Logical AND/OR Conditions . . . . . 9-11
      - 9.6.1.1. Logical AND Conditions . . . . . 9-11
      - 9.6.1.2. Logical OR Conditions . . . . . 9-12
    - 9.6.2. The "Contains String" Operator . . . . . 9-12
  - 9.7. Real Time Variables . . . . . 9-13
  - 9.8. Assigning the Alarm Filter to a Port . . . . . 9-14
  - 9.9. Match Parameter Definition Examples . . . . . 9-14
  
- 10. PBX Inactivity Alarms . . . . . 10-1**
  - 10.1. Schedules and Timers . . . . . 10-1
  - 10.2. Enabling the PBX Inactivity Alarm . . . . . 10-2

---

<b>11. The 80% Full Alarm</b>	<b>11-1</b>
<b>12. The Input Contact Alarms</b>	<b>12-1</b>
12.1. The Optional I/O Monitor	12-1
12.2. Configuring the Input Contact Alarm	12-2
<b>13. Alarm Actions</b>	<b>13-1</b>
13.1. Alarm Actions for Alarm Filter Clues	13-2
13.2. Alarm Action Summary	13-2
13.2.1. None (No Alarm Action)	13-2
13.2.2. Callout	13-3
13.2.3. Alphanumeric Page	13-3
13.2.4. Numeric Page	13-4
13.2.5. SNMP Trap	13-4
13.2.6. Output Contact	13-5
13.2.7. Console	13-5
13.2.8. Email/Text Message	13-6
13.3. The Auto Execute Function	13-7
<b>14. Scheduled Actions</b>	<b>14-1</b>
<b>15. Saving VIP Parameters</b>	<b>15-1</b>
15.1. Saving Parameters to Flash Memory	15-1
15.2. Saving and Restoring Parameters from an ASCII File	15-2
15.2.1. Saving Parameters to an ASCII File (Menu Driven Method)	15-2
15.2.2. Saving Parameters to an ASCII File (Command Driven Method)	15-3
15.3. Configuring the VIP with Saved Parameters	15-5
<b>16. Buffer Functions (Polling)</b>	<b>16-1</b>
16.1. Memory Partitions and Shared Data	16-1
16.1.1. Partitions and Files	16-2
16.1.2. Setting the Partition	16-4
16.1.3. Releasing the Partition	16-5
16.2. Menu Driven Data Release	16-6
16.2.1. The Buffer Functions Menu	16-6
16.2.2. Read Session Parameters	16-8
16.3. Command Driven Data Release	16-9
16.3.1. Command ^B00 (Set/Release Partition)	16-10
16.3.2. The ^B01 Command Line	16-11
16.3.3. Command ^B01 Examples	16-12
16.3.4. Other Commands Used During Data Release	16-13
16.4. Retrieving Data Using FTP Push	16-14
16.4.1. File Names Created by FTP Push	16-19
16.4.2. FTP Push Start Time	16-21
16.5. The FTP Server Feature	16-22
16.5.1. Configuring the FTP Server Feature	16-22
16.5.2. Retrieving Data Using FTP Server	16-24
16.5.3. File Names for the FTP Server Function	16-28
16.5.4. Commands Supported by FTP Server	16-29
16.5.5. Response Messages Generated by the FTP Server Function	16-30
16.6. The Auto Delete Function	16-32
16.7. Zmodem Data Release Mode	16-32

---

<b>17. Other Menu Functions</b> .....	<b>17-1</b>
17.1. System Functions .....	17-1
17.1.1. Security Level .....	17-1
17.1.2. Pass-Through Mode .....	17-2
17.1.3. Monitor Mode .....	17-3
17.1.4. Clear Alarm Condition .....	17-3
17.1.5. Clear Alarm Counters .....	17-4
17.1.6. Download Parameters .....	17-4
17.1.7. Audit Trail .....	17-5
17.1.8. Upload Firmware .....	17-6
17.2. System Diagnostics .....	17-8
17.2.1. Load and Test Memory .....	17-8
17.2.2. Send Test Message .....	17-8
17.2.3. Test Pager .....	17-9
17.2.4. Send Test SNMP Trap(s) .....	17-10
17.3. Default Parameters .....	17-10
<b>18. TCP Port Options</b> .....	<b>18-1</b>
18.1. Standard Telnet Protocol & Raw Socket Mode .....	18-1
18.2. Telnet Pass-Through .....	18-2
18.3. Real Time Mode .....	18-3
18.4. Selective Read .....	18-5
18.5. Multiple Telnet Connections .....	18-7
18.5.1. Conflicts with Other Command Ports .....	18-8
<b>19. Command Reference Guide</b> .....	<b>19-1</b>
19.1. Command Mode Access .....	19-1
19.2. Command Syntax .....	19-2
19.3. Command Help .....	19-3
19.4. Command Summary .....	19-4

**Appendices**

<b>A. Specifications</b> .....	<b>Apx-1</b>
A.1. NetLink-VIP Specifications .....	Apx-1
A.2. NLJ-VIP (NetLink Jr.-VIP) Specifications .....	Apx-2
<b>B. Description of System Interfaces</b> .....	<b>Apx-3</b>
B.1. Input Ports (PBX A, PBX B, AUX) (DB9 Male; DTE) .....	Apx-3
B.2. Console Port (DB-25 Female; DCE) .....	Apx-4
B.2.1. Console Port to 25-Pin PC .....	Apx-4
B.2.2. Console Port to 9-Pin PC .....	Apx-4
<b>C. Supervisor Functions and User Functions</b> .....	<b>Apx-5</b>
<b>D. Alarm Clue Definition Tips</b> .....	<b>Apx-7</b>
<b>E. Customer Service</b> .....	<b>Apx-10</b>
<b>G. ^Bxx Command Summary</b> .....	<b>Apx-11</b>
<b>Index</b> .....	<b>Index-1</b>



---

**List of Figures**

2.1.	Front Panel Indicators (NetLink-VIP Shown)	2-1
2.2.	Back Panel (NetLink-VIP Model)	2-2
2.3.	Back Panel (NLJ-VIP Model)	2-2
3.1.	The Main Menu	3-2
3.2.	The Network Parameters Menu	3-3
4.1.	DC Terminal Block Assembly	4-2
5.1.	Main Menu	5-1
5.2.	System Parameters Menu	5-4
5.3.	Port Selector Menu	5-6
5.4.	PBX Port Configuration Menu (Port A Shown)	5-7
5.5.	Field Suppression: The Lucent Switch Option	5-8
5.6.	Auxiliary Port Configuration Menu	5-10
5.7.	Console Port Configuration	5-12
5.8.	Modem Port Configuration Menu	5-15
5.9.	Dialback Security Configuration Screen	5-19
5.10.	Network Configuration Menu	5-20
5.11.	The Send Email Configuration Menu	5-23
5.12.	The Ping Configuration Menu	5-25
5.13.	The PBX IP Port Configuration Menu	5-26
7.1.	Status Display Menu	7-1
7.2.	Buffer Status Screen	7-2
7.3.	File List (Sample Values Shown)	7-3
7.4.	System Status Screen	7-4
7.5.	Scheduled Action Status Screen (Schedule 1 Shown)	7-5
7.6.	Dialback Security Status Screen	7-6
7.7.	Data Filters & Alarms Status Screen	7-7
7.8.	Alarm Condition Status Screen	7-9
7.9.	PBX Inactivity Alarm Status Screen (Alarm 1 Shown)	7-10
7.10.	80% Full Alarm Status Screen	7-12
7.11.	Input Contact Alarm Status Screen	7-13
7.12.	Reason for Action Screen	7-14
7.13.	PBX Port Status Screen (PBX Port A Shown)	7-15
7.14.	Auxiliary Port Screen	7-16
7.15.	Console Port Status Screen	7-17
7.16.	Modem Port Status Screen	7-19
7.17.	Network Port Status Screen	7-21
7.18.	Network Status Screen	7-23
7.19.	PBX IP Port Status Screen	7-24
7.20.	Alarm Filter Clue Status Screen (PBX Port A, Alarm Filter 1 Shown)	7-25
8.1.	Data Filter Configuration Menu (Data Filter 1 Shown)	8-2
8.2.	Data Filter Format Definition Menu	8-3
8.3.	Data Filter Format Definition Example	8-4
8.4.	The “Contains String” Operator Example	8-8
8.5.	Data Filter Example 1	8-10
8.6.	Data Filter Example 2	8-11
8.7.	Data Filter Example 3	8-11
8.8.	Data Filter Example 4	8-12
9.1.	Alarm Configuration Menu	9-2
9.2.	Alarm Filter Configuration Menu (Alarm Filter 1 Shown)	9-5

## List of Figures (Continued)

9.3. Alarm Filter Format Definition Screen	9-7
9.4. Alarm Filter Format Definition Example	9-7
9.5. Alarm Clue Definition Menu	9-9
9.6. Alarm Filter Format; "Contains String" Example	9-12
9.7. Alarm Filter Format; Match Parameters Example 1	9-15
9.8. Alarm Filter Format; Match Parameters Example 2	9-16
9.9. Alarm Filter Format; Match Parameters Example 3	9-17
9.10. Alarm Filter Format; Match Parameters Example 4	9-18
10.1. PBX Inactivity Alarm Set-Up Menu (Alarm 1 Shown)	10-3
11.1. The 80% Full Alarm Configuration Menu	11-2
12.1. The Alarm Configuration Menu	12-2
12.2. Input Contact Alarm Configuration Menu (Contact 1 Shown)	12-3
14.1. Scheduled Action Configuration Menu (Schedule 1 Shown)	14-2
15.1. System Functions Menu	15-3
16.1. Data Partitions and Files (NetLink-VIP)	16-2
16.2. Data Partitions and Files (NLJ-VIP)	16-2
16.3. Buffer Functions Menu	16-7
16.4. Set Read Session Parameters Menu	16-8
16.5. FTP Push Configuration Menu	16-14
16.6. FTP Push File Names	16-19
16.7. FTP Server Configuration Menu (Defaults Shown)	16-22
16.8. FTP Server Example	16-26
16.9. FTP Server File Names	16-28
17.1. System Functions Menu	17-1
17.2. System Diagnostics Menu	17-8
17.3. Pager Test Menu	17-9
19.1. Command Help Screen	19-3
19.2. More Command Help	19-3
B.1. Data Input Ports (PBX A, PBX B & AUX)	Apx-3
B.2. Console Port to 25-Pin PC	Apx-4
B.3. Console Port to 9 Pin PC	Apx-4

# 1. Introduction

---

The PollCat NetLink-VIP and PollCat NetLink Jr.-VIP (NLJ-VIP) Call Accounting Terminals are highly reliable, PBX data recorders designed for SMDR/CDR data collection and alarm monitoring. Collected call records can be retrieved via TCP/IP network, via FTP client, via modem, or by a local PC connected directly to the VIP unit.

In addition to storing call data, the VIP can also monitor call records for suspicious phone activity or critical alarm conditions. When an alarm is detected, the unit can immediately notify the proper personnel by pager, modem, or SNMP trap. The VIP also provides secure access to connected serial devices such as PBX maintenance ports or Console/AUX ports.

## **Network and Modem Access**

All command functions, including data retrieval and unit configuration, can be accessed via network, modem or local PC. When the VIP is installed in a TCP/IP environment, Telnet is used to access the command mode. If out-of-band access is required, you can also dial-up the VIP's internal modem. Stored data can be reliably retrieved using your terminal emulation program, an FTP client or Zmodem protocol. Password protection and dialback security prevent unauthorized access to control functions.

## **Nonvolatile Flash Memory**

The VIP uses reliable, low-cost flash memory to store call records and operating parameters. This eliminates the need to check and replace depleted batteries. If power to the unit is lost or interrupted, stored data can be retained indefinitely without worrying about low or dead batteries. The VIP is available with 512 K to 64 Megabytes of internal memory. For NetLink-VIP units only, if more memory is needed later, additional memory modules can be easily snapped into place.

## **SNMP Traps**

Alarm messages, memory full status, and a variety of other conditions can be reported to your network manager via standard SNMP traps. SNMP Traps can be used to provide notification when an alarm event occurs, or to perform a wellness check at user selected time intervals.

## Up to Four PBX Inputs

The NetLink-VIP includes four separate data input ports; two PBX ports, an Auxiliary Port and the PBX IP Port. This allows the unit to collect data from four different sources. The Auxiliary Port can be connected to a third PBX, or other data generating device, or used to pass commands to a connected device such as WTI's IPS-800 Internet Power Switch. Communication parameters can be individually defined for each port. When the unit is polled, data from the three ports can either be combined, or read separately. Note that the NLJ-VIP includes only two input ports; the PBX A Port and the PBX IP Port.

## NetLink-VIP Units and NLJ-VIP Units

This User's Guide discusses both NetLink-VIP units and NLJ-VIP (NetLink Jr.-VIP) units. Throughout this User's Guide, both units are referred to as "VIP." The NetLink-VIP includes four input ports, and is also available with expanded memory and the Input Contact option. The NLJ-VIP includes two input ports and 512K of flash memory. All other features function identically, except where noted.

## Disclaimer on Toll Fraud

---

We do not guarantee that if you use the VIP, you will not become the victim of toll fraud. We provide this device to assist you in minimizing your exposure to such losses. By monitoring call records as they are received, you can potentially catch calls that should not be made before they escalate and cost you large sums of money. However, responding to alarms and determining what is fraud and abuse are still up to you. Western Telematic, Incorporated assumes no responsibility for any losses due to improper use of this product.

## Typographic Conventions

---

In this user's guide, typefaces and characters are used as follows:

- |                            |  |
|----------------------------|--|
| <b>^</b> (e.g. <b>^B</b> ) | Indicates a key combination used to invoke a command. For example, " <b>^B</b> " (Control B) indicates that the <b>[Ctrl]</b> key and <b>[B]</b> key should be pressed simultaneously. |
| <b>COURIER FONT</b>        | Indicates characters typed on the keyboard. For example, <b>^B16</b> or <b>^B01</b> .  |
| <b>[Bold Font]</b>         | Text set in bold face and enclosed in square brackets indicates a specific key. For example, <b>[Enter]</b> or <b>[Esc]</b> .  |

## 2. Unit Description

### 2.1. Front Panel Indicators

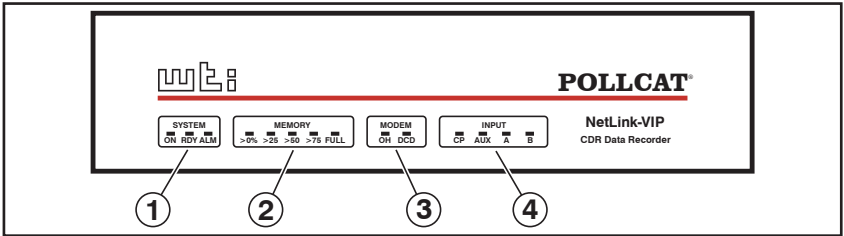

Figure 2.1: Front Panel Indicators (NetLink-VIP Shown)

- ① **SYSTEM Indicators:**
  - **ON:** Lights when AC Power is applied to the unit.
  - **RDY:** Flashes slowly to indicate the unit is operational.
  - **ALM:** Lights when a Toll Fraud Alarm or PBX Inactivity Alarm is triggered.
- ② **MEMORY Indicators:** A bank of five LEDs which light to indicate approximate memory usage.
- ③ **MODEM Indicators:** Two LEDs which indicate modem conditions as follows:
  - **OH:** (Off Hook) Lights when modem is off-hook.
  - **DCD:** (Data Carrier Detect) Lights when carrier is detected.
- ④ **INPUT Indicators:** A bank of four LEDs which indicate data reception as follows:
  - **CP:** Lights when commands are received via the Console Port.
  - **AUX:** Lights when data is received via the AUX Port.
  - **A:** Lights when data is received via PBX Port A.
  - **B:** Lights when data is received via PBX Port B.

**Note:** The NLJ-VIP Model does not include the "B" or "AUX" input ports or LED indicators for these ports.

## 2.2. Back Panel

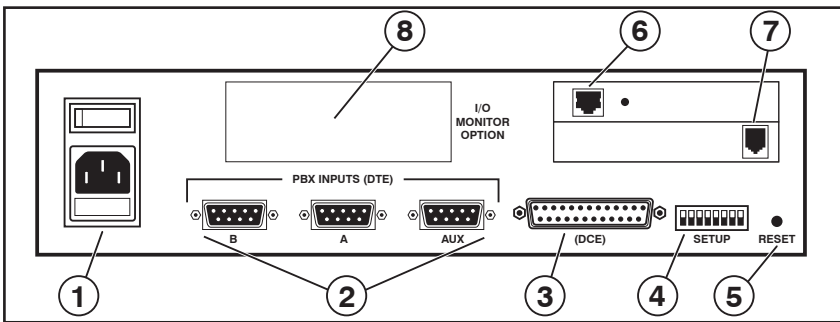

Figure 2.2: Back Panel (NetLink-VIP Model)

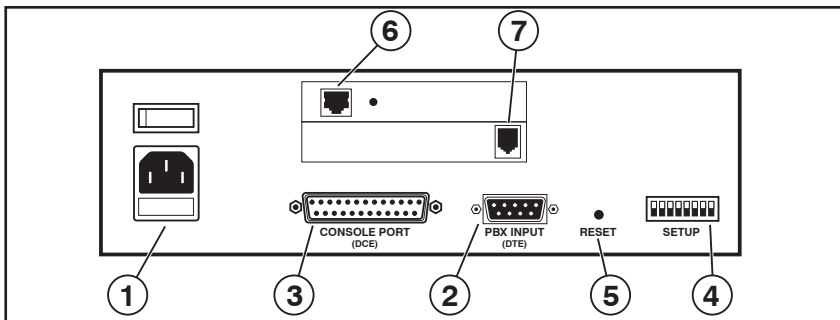

Figure 2.3: Back Panel (NLJ-VIP Model)

- ① **AC Power Components:** (AC Units Only) On/Off Switch and Power Cable receptacle. DC units include a terminal block assembly (Figure 4.1) in place of the power cable receptacle.
- ② **PBX Input Connector(s):** DB9 Connector(s) (DTE) used for connection to your PBX SMDR Port(s).

### Notes:

- NetLink-VIP Models include three PBX Input Connectors for Port A, Port B and the AUX Port.
- NetLink-Jr.-VIP models include only one PBX Input Connector and do not include the AUX Port.
- The AUX Port on the NetLink-VIP model can be connected to a PBX, or used to pass commands to a connected device.

- ③ **Console Port:** For connection to a local PC or terminal.

- ④ **Set-Up Switches:** A bank of eight dip switches that are used to select default options and communication settings.
- ⑤ **Reset Button:** Used to reset the VIP to defaults and clear memory as described in Section 4.3.
- ⑥ **Network Port:** A 10Base-T connector with LED indicator(s). When a network connection is present, the LINK indicator will light.
- ⑦ **Modem Port:** For connection to a telecommunications line.
- ⑧ **I/O Monitor:** (Not Shown - Option for NetLink-VIP Model only) The optional I/O monitor allows the NetLink-VIP to monitor externally supplied signals, and open or close contacts in response to alarms or according to a user-defined schedule.





## 3. Quick Start Guide

---

This Quick Start Guide describes a simplified installation procedure for the VIP hardware, which will allow you to communicate with the unit in order to demonstrate basic features and check for proper operation.

Note that this Quick Start Guide does not provide a detailed description of unit configuration, or discuss advanced operating features in detail. In order to take full advantage of the complete range of features offered by the unit, it is recommended to review the remainder of this User's Guide after performing the Quick Start procedure.

### 3.1. Hardware Installation

---

#### 3.1.1. Apply Power to the VIP

Refer to the power rating nameplate on the VIP back panel, and then connect the unit to an appropriate power source. The VIP features a self-adjusting power supply that automatically adapts for 115 or 230 VAC operation. Set the Master Power Switch on the VIP back panel to the ON position; the front panel indicators should light. After a brief pause, the RDY indicator should begin to flash, indicating that the unit is ready to receive commands.

#### 3.1.2. Connect your PC to the VIP

In order to configure the VIP unit, invoke commands or retrieve data, you must first access the VIP command mode. The VIP offers three different methods for activating the command mode; from a local PC that is cable connected directly to the VIP Console Port, from a remote PC that communicates with the VIP via modem, or from a remote PC that communicates with the VIP via Ethernet connection. To connect your PC to the VIP, proceed as follows:

- **Control via Network:** Connect your 10Base-T or 100Base-T network interface to the VIP's Network Port.
- **Control via Console Port:** Use the supplied null modem cable to connect your PC COM port to the VIP's Console Port.
- **Control via Modem:** Connect your phone line to the VIP's Modem Port.

**Note:** The VIP features a 10Base-T, half duplex Interface. When connecting to a 100Base-T interface, most router switches will autosense to determine if the device is 100Base-T or 10Base-T, and then configure the network interface accordingly. If your router switch does not autosense, the network interface port must be manually set to 10Base-T, half duplex mode.

```
PollCat NetLink-VIP Main Menu:      Supervisor Mode

FUNCTIONS:                          CONFIGURATION:

1. Status Displays                  21. Default Parameters
2. Buffer Functions                 22. Port Configuration
3. System Functions                23. System Parameters
4. System Diagnostics              24. Scheduled Action Parameters
5. ^Bxx Command Help               25. Alarm Configuration
6. Recall Parameters               26. Data Filter Configuration
7. Save Parameters                 27. FTP Push Configuration
8. Exit Command Mode              28. FTP Server Configuration

Enter selection ...
```

Figure 3.1: The Main Menu

## 3.2. Communicating with the VIP

---

The command mode can be accessed via the Console Port, network connection or Modem. Note however, that before you can communicate with the unit via network, you must first access command mode via Modem or Console Port and define certain network parameters.

### 3.2.1. Access via Console Port or Modem

To access command mode via Console Port or Modem, proceed as follows:

1. **Console Port (Local Access):** This is the simplest way to access the VIP command mode. Your system communicates with the VIP via a direct cable connection to the Console Port.
  - a) Start your communications program (e.g., Hyperterminal or Tera Term Pro<sup>®</sup>) and press **[Enter]**. The VIP will respond with the "POLL-CAT-NETLINK" (Password) prompt.
  - b) Key in your password and press **[Enter]**. The default Supervisor password is "SUPER" (all uppercase, no quotes.)
2. **Access Via Modem:** Start your communications program and dial the number for the phone line that is connected to the VIP.
  - a) After the carrier is detected, the VIP will respond with the "POLL-CAT-NETLINK" (Password) prompt.
  - b) Key in your password and press **[Enter]**. The default Supervisor password is "SUPER" (all uppercase, no quotes.)

**Note:** The VIP will allow 5 attempts to enter a valid password. If a valid password is not entered in 5 attempts, the unit will disconnect.

After a brief pause, the "READY" message will be sent. Press **[Enter]** to display the VIP Main Menu as shown in Figure 3.1.

```

NETWORK PORT:          NIC Installed

COMMUNICATION SETTINGS
1. IP Address:         192.168.168.168
2. Subnet Mask:        255.255.255.0
3. Gateway Addr:      (undefined)
4. SNMP Manager 1:    (undefined)
5. SNMP Manager 2:    (undefined)
6. SNMP Community:    public
7. Reset Network
8. Send MSS:           1460
9. Send Email
10. Ping

GENERAL PARAMETERS
11. Command Echo:     On
12. Response Type:    Inhibit Menu
13. "Sure" Prompt:    On
14. CMD Timeout:      15 Mins
15. Audit Trail:      Off

ACTION PARAMETERS
16. Action Delay:     10 Secs
Enter selection, Press <ESC> to return to previous menu ...

OUTPUT PARAMETERS
21. Output Mode:      ASCII Record
22. Data on ^B01:     On
23. Hold End Data:    On
24. Line # Tag:       Off
25. Send Compress:    Off
26. Auto Delete:      On

OUTPUT PARAMETERS (BINARY BLOCK)
27. Transmit Att:     3
28. Transmit Delay:   5 Secs
29. DLE Stuffing:     Off

```

Figure 3.2: The Network Parameters Menu

### 3.2.2. Access via Network

Before you can communicate with the VIP via network, you must first access command mode via the Console Port or Modem, and set up network parameters as described below.

1. **Access Command Mode:** Access the VIP command mode via Console Port or Modem as described in the previous section. When the READY message appears, press **[Enter]** to display the main menu.
2. **Configure the Network Port:** At the Main Menu, type **22** and press **[Enter]** to display the Port Configuration Menu. At the Port Configuration Menu, type **6** and press **[Enter]** to display the Network Port Configuration menu (Figure 3.2):

**Note:** Consult your network administrator to determine appropriate IP settings.

- a) **IP Address:** Type **1** and press **[Enter]**. (**Default = undefined.**)
  - b) **Subnet Mask:** Type **2** and press **[Enter]**. (**Default = 255.255.255.0**)
  - c) **Gateway Address:** Type **3** and press **[Enter]** (If needed.) (**Default = undefined.**)
3. **Save Configuration Parameters and Exit Command Mode:** Press the **[Esc]** key several times to return to the main menu. From the main menu, type **7** and press **[Enter]** to save the network parameters entered in Step 2 above. After parameters have been saved, type **8** and press **[Enter]** to exit from command mode.

4. **Access Command Mode via Network:** Start your communications program, and then key the VIP's IP address (defined in Step 2a) into the address field. Select TCP Port 23 and then click OK or press **[Enter]**.
  - a) The "POLLCAT-NETLINK" (Password) prompt will be displayed. The default Supervisor password is "SUPER" (all uppercase, no quotes.)
  - b) After a brief pause, the READY message will be displayed. Press **[Enter]** to display the VIP main menu.

After you have successfully accessed command mode, you are then ready to connect your PBX, configure the VIP unit and begin collecting data.

### **3.3. Connect your PBX to the VIP**

---

VIP units can collect data via cable from up to three local PBX units, and can also collect data via network connection to a remote PBX unit. PollCat NetLink-VIP units provide three PBX input ports for cable connection to local PBX units, and NLJ-VIP units provide one PBX input port for cable connection to a local PBX unit. Both VIP models include one PBX IP Input port to allow data to be collected via network.

- **Connecting a PBX to the VIP PBX Input Port:** Use an appropriate data cable to connect your PBX SMDR port to the VIP's PBX Input Port. The serial PBX Input Port is a male, DB9 connector, wired in a DTE configuration. The type of cable used will vary, depending on the configuration of your PBX. For a description of VIP's PBX Input Port interface, please refer to Appendix B. Section 5.4.1 describes the procedure for configuring the PBX input port(s).
- **Connecting to a PBX via the Network Port (PBX-IP Port):** Refer to your PBX user's guide, and then configure your RSP compatible PBX to send data to the IP address for the VIP unit (defined in Step 2a in Section 3.2.2.) In the default configuration, the VIP will receive data via port number 9000. Section 5.4.6 describes the procedure for configuring the PBX IP port.

This completes the Quick Start Guide for the VIP. Prior to placing the unit into operation, it is recommended to refer to the remainder of this User's Guide for complete installation, configuration and operation procedures. If you have further questions regarding the VIP unit, please contact WTI Customer Support as described in Appendix E.

## 4. Hardware Installation

---

The hardware installation procedure includes the following steps:

1. Connect the VIP unit to an appropriate power supply (see Section 4.1).
2. Use the Set-Up Switches to select default communication parameters and options (see Section 4.2).
3. Reset the VIP unit and clear the flash memory (see Section 4.3).
4. Connect the data cables, network cable and telephone line (see Section 4.4)

### 4.1. Connect the VIP to Power Supply

---

#### Notes:

- When Switch 8 is UP (enable Power Up Default) and there is a power interruption, baud rates will return to the default values selected by Set-Up Switches 1 through 5.
- After configuring the unit with menu selected parameters, you may wish to return Set-Up Switch 8 to the DOWN position. This will cause the VIP to use menu selected parameters whenever the unit is powered off and on.



**CAUTION:** This device should only be operated with the type of power source indicated on the instrument nameplate. If you are not sure of the type of power service available, please contact your local power company.



#### 4.1.1. AC Powered Units

Plug the power cable into the receptacle on the VIP back panel. The VIP features a self-adjusting power supply that automatically adapts for 115 or 230 VAC. Place the AC Power Switch in the ON position to apply power, the ON indicator will light and the RDY indicator will flash.

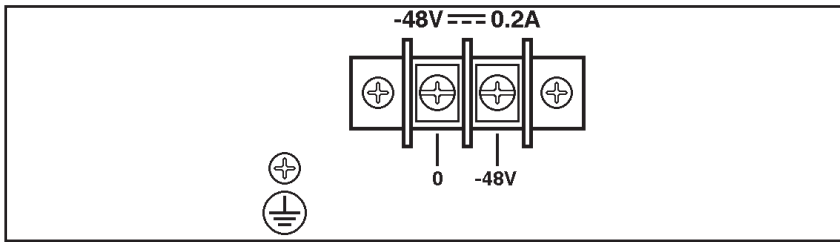

Figure 4.1: DC Terminal Block Assembly

### 4.1.2. DC Powered Units

Attach the wires from your -48V DC power source (0.2 Amp Max.) to the screw terminals, and then connect your ground line to the ground screw.

## 4.2. Set-Up Switches

The Set-Up Switches select default communication parameters and enable options such as Dialback Security, the Console Port Password, and Power Up Default. Note that operating parameters are selected via the port configuration menus as described in Section 5.4.

### 4.2.1. Default Baud Rate for Console Port (Sw1, Sw2, Sw3)

Set-Up Switches One, Two, and Three select the default Baud Rate for the Console Port. After the VIP is installed, the Port Configuration menu (Main Menu, item 22) can be used to select the operating baud rate for the Console Port.

Baud	Switch 1	Switch 2	Switch 3
9600 *	Down	Down	Down
38.4 K	Up	Down	Down
19.2 K	Down	Up	Down
4800	Up	Up	Down
2400	Down	Down	Up
1200	Up	Down	Up
600	Down	Up	Up
300	Up	Up	Up

\* = Factory Setting

### 4.2.2. Default Baud Rate for PBX Port A, PBX Port B, and AUX Port (Sw4, Sw5)

Switches Four and Five select default Baud Rates for PBX Ports A and B and the AUX Port. The Port Configuration menus can be used to define operating baud rates as described in Section 5.4. Note that NLJ-VIP units do not include PBX Port B or the AUX Port.

Baud	Switch 4	Switch 5
9600 *	Down	Down
4800	Up	Down
1200	Down	Up
300	Up	Up

\* = Factory Setting

### 4.2.3. Dialback Security Mode (Sw6)

This feature provides additional security for modem access to the Command Mode. Dialback Security will prompt callers to enter a password. If a valid password is entered, the VIP will disconnect and then call the user-defined number for that password before allowing access to Command Mode. Section 5.4.4.1 describes the procedure for configuring Dialback Security.

Switch 6	Dialback Security Mode
Down *	Dialback Security Disabled
Up	Dialback Security Enabled

\* = Factory Setting

### 4.2.4. Console Port Password (Sw7)

Switch Seven enables/disables the Console Port Password. The default Supervisor Password is "SUPER"; the default User 1 Password is "SMDR", the default User 2 Password is undefined. For a summary of User Mode and Supervisor Mode functions, please refer to Appendix C.

**Note:** If the Console Port password is disabled, the VIP will always start up in Supervisor Mode.

Switch 7	Console Port Password
Down *	Password Not Required
Up	Password Required

\* = Factory Setting

### 4.2.5. Power Up Default (Sw8)

The Power Up Default allows the user to reset communication parameters to default settings without entering Command Mode.

**Note:** If you have changed Set-Up Switches 1 through 5, and you wish to clear all menu selected parameters, Switch 8 should be set in the UP position. This will allow default parameters selected by the Set-Up Switches to take effect when the VIP is powered up.

When the Power Up Default is enabled, the VIP will reset the following parameters after an interruption in power:

- **Input Port Communication Parameters:** The Baud rate for PBX Ports A and B, and the AUX Port are set according to the Set-Up Switches, rather than command selected parameters. All three ports will be set at 7 bits, even parity, one stop bit. Note that NLJ-VIP units do not include PBX Port B or the AUX Port.
- **Console Port Communication Parameters:** The Baud rate will be set according to the Set-Up Switches. The Port will also be set for 8 bits, no parity, one stop bit.
- **Modem Port Communication Parameters:** The port will be set to 57600, 8 bits, no parity, one stop bit.
- **Passwords:** The Supervisor Password will default to "SUPER". The User 1 Password will default to "SMDR". In the default state, the User 2 Password is not defined.

**CAUTION:** If Set-Up Switch 8 is UP (enable Power Up Default), and there is a loss of power, port parameters will be set to the default values selected by Set-Up Switches 1 - 6 rather than the menu selected parameters.

If the Power Up Default is disabled (Sw8 = Down), when there is a power interruption, The VIP will be configured according to the parameters currently saved in flash memory.

Switch 8	Power Up Default
Down *	Disabled (Use Saved Port Parameters)
Up	Enabled (Re-Set to Switch-Selected Default Port Parameters)

\* = Factory Setting



---

### **4.3. Reset to Defaults**

---

This procedure will reset the VIP to the settings indicated by the Set-Up switches, reset all menu selected parameters to factory defaults, and clear memory.

When the unit is shipped from the factory, defaults are reset and the memory is cleared. However, if the VIP has been previously installed, or if you have changed switch settings, this procedure should be performed. It is also recommended to reset the unit after installing additional memory modules.

#### **Notes:**

- When this procedure is performed, all menu defined parameters will be cleared. If the unit has already been configured, parameter settings should be saved (as described in Section 15.2), before beginning this procedure.
- If the VIP unit has the base 512K memory option (no SIMMs), all stored data will be cleared. If the unit has collected data, it is recommended to retrieve stored data (as described in Section 16) before beginning this procedure.

To reset defaults and clear memory, proceed as follows:

1. Press the Main Power Switch to the OFF position.
2. Press and hold the Reset Button (located on the back panel) while pressing the Main Power Switch to the ON position. Continue to hold the Reset Button until the front panel indicators blink twice.
3. After the indicators blink, release the Reset Button. After a brief pause, the front panel indicators will blink three times. This indicates that the reset procedure is complete.

## 4.4. Connecting Cables and Phone Line

---

Your cable layout should account for the following factors:

**Command Mode Access:** The VIP provides several methods for accessing Command Mode

- **Network Access:** The VIP is managed via Ethernet. Note that initial setup cannot be performed via network.
- **Local Access:** The VIP is managed by a local PC connected to the Console Port.
- **Remote Access:** The VIP is managed by a remote PC that communicates with the unit via modem.
- **Multiple Access:** The VIP can be managed via Network, Console Port, or Modem.

**Alarm Actions:** The VIP offers several methods that can be used to notify users when an alarm has been generated:

- **SNMP Trap:** An SNMP Trap is sent to a network management station.
- **Console Port Action:** Alarms are sent to a local PC connected to the Console Port.
- **Modem or Pager:** Alarms are sent to a remote PC or Pager.
- **Email or Text Message:** Alarms are sent via email or text message, to up to two user-defined email addresses.
- **Output Contacts:** (Optional - Not Available on NLJ-VIP units.) The Output Contacts can be opened or closed.
- **Combination of Methods:** Each alarm is directed to a different target. The alarm configuration screens select notification methods for each alarm.

The physical layout is determined by the Command Mode access method and Alarm Actions required for your application. Determine which method(s) will be used and install cables as outlined in the following sections.

**CAUTION:** Prior to connecting data lines, make certain that cables are compatible with The VIP. Please refer to the interface descriptions in Appendix B.

#### **4.4.1. PBX Inputs A and B and AUX Port**

The PBX Inputs and the AUX port are used for connection to your PBX SMDR Port. The AUX Port can be connected to a third PBX, or used to collect data from, or pass commands to other devices. For a description of the port interface, please refer to Appendix B. Note that NLJ-VIP units do not include PBX Port B or the AUX Port.

#### **4.4.2. Modem Port**

When an outside phone line is connected to the Modem Port, the VIP can be managed and polled via modem. When an alarm is generated, the VIP can also provide notification via modem or pager.

#### **4.4.3. Console Port**

The Console Port can be connected to a local PC, which is used to manage and poll the VIP unit. Please refer to Appendix B for a description of the Console Port interface.

#### **4.4.4. Network Port**

The Network Port allows connection to a TCP/IP network. When installation is complete, the VIP unit can be managed and polled via network. The VIP can also provide alarm notification via SNMP trap. Use a straight wired 10Base-T cable.

**Note:** The VIP features a 10Base-T, half duplex network interface. When connecting to a 100Base-T interface, most router switches will autosense to determine if the device is 100Base-T or 10Base-T, and then configure the network interface accordingly. If your router switch does not autosense, the network interface port must be manually set to 10Base-T, half duplex mode.



## 5. Configuration

---

When the VIP unit is shipped from the factory, options and parameters are set to fit the requirements of most call accounting applications. In many cases, if you do not choose to include the VIP's advanced features, no further configuration is required.

However, if you do intend to use advanced features (such as the Data Filter or Alarm Filter), or if your application requires parameters other than the defaults described in this section, the unit must be properly configured. This section describes how to reconfigure the VIP to meet the requirements of almost any data collection application.

Although The VIP provides a substantial assortment of advanced program features, it is not necessary to include all of these features in your system configuration. You may wish to complete the basic set-up first, and then add optional features as needed.

When configuring the unit, note that the Status Screens can be accessed via item 1 in the Main Menu. This allows you to determine the current state of any feature, and verify that parameters are correctly defined. For more information on the Status Screens, please refer to Section 7.

### 5.1. Access to the Command Mode

---

When the command mode is active, the unit will display a series of menus used to select parameters, enable options, and retrieve stored data.

During initial configuration, command mode can only be accessed via the Console Port or Modem Port. After network parameters have been defined, you will also be able to access command mode via the Network Port. To access command mode for initial configuration, proceed as follows:

```
PollCat NetLink-VIP Main Menu:      Supervisor Mode
FUNCTIONS:                            CONFIGURATION:
1. Status Displays                    21. Default Parameters
2. Buffer Functions                    22. Port Configuration
3. System Functions                   23. System Parameters
4. System Diagnostics                 24. Scheduled Action Parameters
5. ^Bxx Command Help                 25. Alarm Configuration
6. Recall Parameters                  26. Data Filter Configuration
7. Save Parameters                    27. FTP Push Configuration
8. Exit Command Mode                  28. FTP Server Configuration

Enter selection ...
```

Figure 5.1: Main Menu

1. **Local Access:** To communicate via the Console Port, start your communications program (e.g. ProComm™).
  - a) If Set-Up Switch 7 is UP (enable Console Port Password), the system will send the "PollCat-NetLink" (Password) Prompt.
  - b) Key in the password (case-sensitive), press **[Enter]**. The Default Supervisor Password is **SUPER**.
2. **Access Via Modem:** Start your communications program (e.g., ProComm) and dial the VIP.
  - a) The unit will send the "PollCat-NetLink" (Password) prompt after the carrier is detected.
  - b) Key in the password (case-sensitive), press **[Enter]**. The Default Supervisor Password is SUPER.
3. **Access via Network:** During initial configuration, the VIP cannot be accessed via Network, because parameters such as the IP address and gateway mask have not been defined yet. After network parameters have been defined (see Section 5.4.5), a Telnet session can be established using the following format:

**telnet ipaddress port [Enter]**

Where:

<b>ipaddress</b>	The VIP's IP Address
<b>port</b>	(Optional) The desired Port Number. If omitted, telnet will connect to port #23 by default; Command Echo will be set according to the VIP's current configuration, and \$FF Stuffing will be enabled. Options: <b>2001</b> Behaves same as port #23. <b>3001</b> Preconfigured with Echo enabled, and \$FF Stuffing Off.

**Notes:**

- The VIP will allow 3 attempts to enter a valid password. If a valid password is not entered in 3 attempts, the VIP will disconnect.
- If an invalid password is entered, the VIP will respond with the ERROR message.

After a brief pause, the VIP Main Menu will appear as shown in Figure 5.1.

---

## 5.2. Menu System Conventions

---

1. **Access to Submenus:** All menus are key activated. To access a menu, key in the number for the desired item and press **[Enter]**.
2. **User Level / Supervisor Level Functions:** Note that most configuration menus are not available in User Mode. In order to perform the setup procedures described in this section, the Supervisor Mode must be active. The top of the Main Menu indicates whether User or Supervisor Mode is currently selected.

To switch from User Mode to Supervisor Mode, select Main Menu Item 3 "System Functions". When the System Functions menu appears, select Item 1 "Security Level", and select Supervisor. Key in the Supervisor password (Default = SUPER) and press **[Enter]**.

For more information on User functions and Supervisor functions, please refer to Appendix C.

3. **Save Parameters:** After the VIP has been properly configured, it is recommended to save parameters to flash memory. If parameters are not saved, the VIP will revert to the previous configuration when power to the unit is switched off or interrupted. To save parameters, go to the Main Menu, type **7** and press **[Enter]**.

### 5.2.1. Script Access to Menu Functions

The VIP menu functions can also be accessed using scripts. This allows you to create polling programs that select items from command menus in order to change parameters. When writing polling software, use the following conventions:

1. **Wait for Menu:** To allow the polling program to determine when a menu has been completely sent, search for the character(s) at the end of the menu. For most menus, the last three characters will be an ellipsis (three periods).
2. **Selecting Menu Items:** Specify the desired menu item by number, followed by a carriage return.
3. **Moving Up One Level:** To exit from a menu and return to the previous menu, send an Escape character.

```
SYSTEM PARAMETERS:

1. Supervisor Password:  (...)
2. User Password 1:      SMDR
3. User Password 2:      (undefined)
4. Site ID Msg:          (undefined)
5. Wrap-Around:         Off
6. Real-Time-Clock:     06/18/2004 Fri 16:39:05
7. Alm Data Wrap-Arnd:  Off

Enter selection,
Press <ESC> to return to previous menu ...
```

Figure 5.2: System Parameters Menu

---

### 5.3. Set System Parameters

---

The System Parameters menu (Figure 5.2) is used to set common parameters, such as command mode Passwords and the Site ID Message. To access the System Parameters menu, go to the Main Menu, type **23** and press **[Enter]**. The following items can be configured via this menu:

1. **Supervisor Password:** Defines the Supervisor password. When this password is entered at the Password Prompt, the VIP will start up in Supervisor Mode, allowing access to all menu and command functions. **(Default = SUPER.)**
2. **User Password 1:** Defines the first User Password. When entered at the Password prompt, the VIP will start up in User Mode, allowing limited access to menu and command functions. **(Default = SMDR.)**
3. **User Password 2:** Defines the second User Password. When entered at the Password prompt, the VIP will start up in User Mode, allowing limited access to menu and command functions. **(Default = undefined.)**
4. **Site ID Message:** Defines a text string (up to 32 char.) that identifies the location where the unit is installed. If this item is defined, the Site ID will be displayed prior to the Command Prompt, each time command mode is accessed. The Site ID can also be displayed via the status screens (Main Menu, Item 1). **(Default = undefined.)**

#### Notes:

- If the Site ID message begins with an underscore (**\_**), the message will be displayed *after* the command prompt. However, the underscore character will not appear when the Site ID is displayed.
- If the Console Port Password is disabled (Sw7=Down), the Site ID message will not be displayed when the unit is contacted via the Console Port.



- 
5. **Wrap-Around:** If internal memory becomes full, the wrap-around option allows new data to be written over older data, enabling the unit to continually recycle its memory. While command mode is active, new data will not overwrite older data in the current partition. Any new data will be stored outside the top boundary. If memory is full, no additional data will be stored while command mode is active. **(Default = On.)**

**Note:** When Wrap-Around is enabled and memory becomes full, there will be a noticeable delay while the unit clears old data and writes new data to flash memory. During this period, the VIP will delay response to additional commands until the wrap-around process is complete. Note that newly received data will *not* be lost during this delay.
  6. **Real-Time Clock:** Sets the VIP's internal clock and calendar. Since time dependent features (e.g. Scheduled Actions, PBX Inactivity Alarm) rely on the internal clock, it is important that the clock and calendar are accurately set.
  5. **Alarm Data Wrap-Around:** This feature is identical to item 6 above, except that the Alarm Data Wrap-Around only applies to data that matched a user-defined Alarm Clue. For more information on Alarms and Alarm Clues, please refer to Section 9. **(Default = Off.)**

```
PORT CONFIGURATION:

1. PBX Port A
2. PBX Port B
3. Auxiliary Port
4. Console Port
5. Modem Port
6. Network Port
7. PBX IP Port

Enter selection,
Press <ESC> to return to previous menu ...
```

Figure 5.3: Port Selector Menu

---

## 5.4. Port Configuration

---

To configure PBX Port A, PBX Port B, the AUX Port, Console Port, Modem Port or Network Port, go to the Main Menu, type **22** and press **[Enter]**. The Port Selector Menu (Figure 5.3), will be displayed. To select and configure ports, proceed as follows. Note that NLJ-VIP units do not include PBX Port B or the AUX Port.

### 5.4.1. PBX Port A and PBX Port B

From the Port Selector Menu, type 1 (for PBX Port A) or 2 (for PBX Port B) and then press **[Enter]**. Both configuration menus include the following items:

#### Communication Settings:

1. **Baud Rate:** Selects the baud rate for this port. Any standard rate from 1200 bps to 115.2K bps. **(Default values are selected by Set-Up Switches 4 and 5.)**
2. **Bits/Parity:** Selects Bits/Parity for this port; 8-None, 7-Even, 7-Odd, or 7-None. **(Default = 7-Even.)**
3. **Stop Bits:** Selects stop bits for this port. **(Default = 1.)**
4. **Handshake Mode:** Selects flow control for this port; XON/XOFF, RTS/CTS, both, or None. **(Default = None.)**

#### Input Parameters:

11. **Time/Date Stamp:** The date stamp can be inserted at the beginning of each record received by this port. This prompt is used to disable the function, or select the short format or long format. The short format (PollCat III Compatible) lists Month, Date, Hour and Minute; the long format lists Month, Date, Year, Hour, Minute, and Second. **(Default = Off.)**
12. **Serial Number Stamp:** Inserts a six digit number at the beginning of records received by this port. **(Default = Off.)**

```

PBX PORT A:

COMMUNICATION SETTINGS
1. Baud Rate: 9600
2. Bits/Parity: 7-Even
3. Stop Bits: 1
4. Handshake Mode: None

INPUT PARAMETERS
11. Time/Date Stmp: Off
12. Serial No Stmp: Off
13. Strip Non-Prnt: On
14. End Character: ^J
15. Alarm Filter: Off
16. Store Alm Data: Alarm
17. Data Filter: Off
18. PBX Inact Alm: Off

FIELD SUPPRESSION
31. Lucent Switch

Enter selection,
Press <ESC> to return to previous menu ...

```

Figure 5.4: PBX Port Configuration Menu (Port A Shown)

13. **Strip Non-Printables:** Conserves memory by excluding characters such as Nuls and Dels. **(Default = On.)**
14. **End Character:** Defines the End-of-Record (EOR) character that the VIP expects to see at the end of each record received at this port. **(Default = ^J (Line Feed).)**
15. **Alarm Filter:** Enables/disables the Alarm Filter and selects the Alarm Filter Format for this port. The Alarm Filter monitors data, and notifies the user when specific types of data are detected. For more information, please refer to Section 9. **(Default = Off.)**
16. **Store Alarm Data:** Determines where the VIP will store alarm data received via this port. Alarm Records can be stored in the Alarm File, the Standard (non-alarm) File, or both files. For more information, please refer to Section 16.1.1. **(Default = Alarm.)**
17. **Data Filter:** Enables/disables the Data Filter and selects the Data Filter Format used by this port. The Data Filter conserves memory and cuts polling time by excluding records not needed for your application. For more information, please refer to Section 8. **(Default = Off.)**
18. **PBX Inactivity Alarm:** Enables/disables the PBX Inactivity Alarm and selects the format for this port. The inactivity alarm monitors the flow of data from the PBX and notifies the user if the flow stops. For further instructions, please refer to Section 10. **(Default = Off.)**

#### Field Suppression:

31. **Lucent Switch:** This Item can be used to suppress the phone number field in certain data records, as described in Section 5.4.1.1. This feature is useful in countries that prohibit the transfer of phone number records via network.

```
LUCENT SWITCH:

GENERAL PARAMETERS
1. Supp Number: Off
2. Supp Trunk: Off
3. Call Direction: Outgoing
4. Num Chars Supp: 4

FIELD LOCATION
11. Dest Num Loc: 16
12. Src Num Loc: 34
13. In Trunk Loc: 46
14. Out Trunk Loc: 50

FIELD LENGTH
21. Dest Num Len: 18
22. Src Num Len: 12
23. In Trunk Len: 4
24. Out Trunk Len: 4

Enter selection,
Press <ESC> to return to previous menu ...
```

Figure 5.5: Field Suppression: The Lucent Switch Option

### 5.4.1.1. Field Suppression; The Lucent Switch Feature

This feature is used to suppress portions of the data record that may contain phone numbers and trunk numbers, allowing HIPPA compliant data transmission. This feature is useful in situations where either local laws or regulating agencies prohibit the transmission of phone numbers. The Lucent Switch configuration menu offers the following options:

#### General Parameters:

1. **Suppress Number:** When enabled, all or part of each phone number will be suppressed and not included in transmitted call records. This item can be used to select destination numbers, source numbers, both types of numbers or neither (**Off.**) (**Default = Off.**)
2. **Suppress Trunk:** When enabled, all or part of trunk numbers will be suppressed and not included in transmitted call records. This item can be used to select the inbound trunk, outgoing trunk, both or neither (**Off.**) (**Default = Off.**)
3. **Call Direction:** This item is used to determine if the VIP will suppress incoming phone numbers, outgoing phone numbers or both types of numbers. (**Default = Outgoing.**)
4. **Number of Characters Suppressed:** The number of characters (starting from the right hand edge of the field) that will be suppressed. This value will be applied to both incoming calls and outgoing calls (if selected via Item 3.) (**1 to 32 Characters; Default = 4.**)

**Field Location:**

11. **Destination Number Location:** This item is used to define the beginning of the field that is normally used to store the destination phone number. **(1 to 216 Characters; Default = 16.)**
12. **Source Number Location:** Defines the beginning of the field that is normally used to store the source phone number. **(1 to 216 Characters; Default = 34.)**
13. **Inbound Trunk Location:** Defines the beginning of the field that is normally used to store the inbound trunk number. **(1 to 216 Characters; Default = 46)**
14. **Outbound Trunk Location:** Defines the beginning of the field that is normally used to store the outbound trunk location. **(1 to 216 Characters; Default = 50.)**

**Field Length:**

21. **Destination Number Length:** This item is used to define the length of the field that is normally used to store the destination phone number. **(1 to 32 Characters; Default = 18.)**
22. **Source Number Length:** Defines the length of the field that is normally used to store the source phone number. **(1 to 32 Characters; Default = 12.)**
23. **Inbound Trunk Length:** Defines the length of the field that is normally used to store the inbound trunk number. **(1 to 32 Characters; Default = 4.)**
24. **Outbound Trunk Length:** Defines the length of the field that is normally used to store the outbound trunk number. **(1 to 32 Characters; Default = 4.)**

```

AUXILIARY PORT:

COMMUNICATION SETTINGS
1. Baud Rate: 9600
2. Bits/Parity: 7-Even
3. Stop Bits: 1
4. Handshake Mode: None

INPUT PARAMETERS
11. Time/Date Stmp: Off
12. Serial No Stmp: Off
13. Strip Non-Prnt: On
14. End Character: ^J
15. Alarm Filter: Off
16. Store Alm Data: Alarm
17. Data Filter: Off
18. PBX Inact Alm: Off
19. Port Mode: Store Data

FIELD SUPPRESSION
31. Lucent Switch

Enter selection,
Press <ESC> to return to previous menu ...

```

Figure 5.6: Auxiliary Port Configuration Menu

### 5.4.2. Auxiliary Port Configuration

The Auxiliary (AUX) Port can be connected to a third PBX SMDR port, or used to pass commands to a connected device. To configure the AUX Port, first go to the Port Selector Menu (Main Menu, item 22). Type **3** and press **[Enter]**; the AUX Port Configuration menu will appear (Figure 5.6). Note that the AUX Port is not present on NLJ-VIP units. The AUX Port Configuration menu includes the following:

**Note:** NLJ-VIP units do not include an AUX Port.

#### Communication Settings:

1. **Baud Rate:** Selects the baud rate for this port; any standard rate from 1200 bps to 115.2K bps. **(Default value is selected by Set-Up Switches 4 and 5.)**
2. **Bits/Parity:** Selects Bits/Parity for this port; 8-None, 7-Even, 7-Odd, or 7-None. **(Default = 7-Even.)**
3. **Stop Bits:** Selects stop bits for this port. **(Default = 1.)**
4. **Handshake Mode:** Selects the flow control mode for this port; XON/XOFF (Software), RTS/CTS (Hardware), both, or None. **(Default = None.)**

#### Input Parameters:

11. **Time/Date Stamp:** The time/date stamp can be appended to the beginning of each record received at this port. This prompt allows the user to disable the function, or select short format or long format. The short format (PollCat III Compatible) lists the Month, Date, Hour and Minute; the long format lists the Month, Date, Year, Hour, Minute, and Second. **(Default = Off.)**

12. **Serial Number Stamp:** Inserts a six digit serial number at the beginning of each record received by this port. **(Default = Off.)**
13. **Strip Non-Printables:** Conserves memory and cuts polling time by excluding non-printable characters (such as Nuls and Dels) from records received at this port. **(Default = On.)**
14. **End Character:** Defines the End-of-Record (EOR) character that the VIP expects to see at the end of each record received at this port. **(Default = ^J (Line Feed).)**
15. **Alarm Filter:** Enables/disables the Alarm Filter and selects the Alarm Filter used by the AUX port. The Alarm Filter can notify the user when specific types of data are detected. For more information, please refer to Section 9. **(Default = Off.)**
16. **Store Alarm Data:** Determines where the VIP will store alarm data received via this port. Alarm Records can be stored in the Alarm File, the Standard (non-alarm) File, or both files. For more information, please refer to Section 16.1.1. **(Default = Alarm.)**
17. **Data Filter:** Enables/disables the Data Filter and selects the Data Filter used by this port. For more information on the Data Filter, please refer to Section 8. **(Default = Off.)**
18. **PBX Inactivity Alarm:** Enables/disables the PBX Inactivity Alarm for this port. The PBX Inactivity Alarm monitors the flow of data from the PBX Ports and notifies the user if the flow stops. For more information, please refer to Section 10. **(Default = Off.)**
19. **Port Mode:** Selects the operating mode for the AUX Port. If the AUX Port will be connected to a PBX, the Port Mode should be set to Store Data. If the AUX Port will be used to pass commands to a connected device, the Port Mode should probably be set to Discard Data. **(Default = Store Data.)**

**Field Suppression:**

31. **Lucent Switch:** This Item can be used to suppress the phone number field in certain data records, as described in Section 5.4.1.1. This feature is useful in countries that prohibit the transfer of phone number records via network.

```

CONSOLE PORT:

COMMUNICATION SETTINGS
1. Baud Rate: 9600
2. Bits/Parity: 8-None
3. Stop Bits: 1
4. Handshake Mode: RTS/CTS

OUTPUT PARAMETERS
21. Output Mode: ASCII Record
22. Data on ^B01: On
23. Hold End Data: On
24. Line # Tag: Off
25. Send Compress: Off
26. Auto Delete: Off

OUTPUT PARAMETERS (BINARY BLOCK)
27. Transmit Att: 3
28. Transmit Delay: 5 Secs
29. DLE Stuffing: Off

GENERAL PARAMETERS
11. Command Echo: On
12. Response Type: Inhibit Menu
13. "Sure" Prompt: On
14. CMD Timeout: 15 Mins
15. Audit Trail: Off

ACTION PARAMETERS
16. Action Delay: 10 Secs
Enter selection, Press <ESC> to return to previous menu ...

```

Figure 5.7: Console Port Configuration

### 5.4.3. Console Port Configuration

The Console Port is used for connection to a local control device, such as a PC or terminal. To configure the Console Port, first go to the Port Selector Menu (Main Menu, item 22). Type **4** and press **[Enter]**. The Console Port Configuration Menu (Figure 5.7) will be displayed. The following options are available:

#### Communication Settings:

1. **Baud Rate:** Selects the baud rate for this port; any standard rate from 1200 bps to 115.2K bps. **(Default value is selected by Set-Up Switches 1, 2, and 3.)**
2. **Bits/Parity:** Selects Bits/Parity for this port; 8-None, 7-Even, 7-Odd, or 7-None. **(Default = 8-None.)**
3. **Stop Bits:** Selects stop bits for this port. **(Default = 1.)**
4. **Handshake Mode:** Selects the flow control mode for this port; XON/XOFF (Software), RTS/CTS (Hardware), both, or None. **(Default = RTS/CTS.)**

#### General Parameters:

11. **Command Echo:** Enables / Disables the command echo for this port. During set-up, it may be helpful to enable the command echo. This allows keystrokes sent to the VIP unit to be displayed on your monitor. **(Default = On.)**



12. **Response Type:** Determines how the port will react when command mode is activated. If "Display Menu" is selected, the VIP will immediately display the Main Menu when command mode is activated. If "Inhibit Menu" is selected, the VIP will not display the Main Menu until [Enter] is pressed. **(Default = Inhibit Menu.)**
13. **"Sure" Prompt:** When irreversible commands (such as "Erase Data") are invoked at this port, the VIP can display the "Sure" prompt to allow one last chance to verify that the command should be executed. **(Default = On.)**
14. **Command Timeout:** Sets the Timeout value for this port. When the VIP detects no command activity at this port for the specified timeout period, the port will exit command mode and disconnect. **(Default = 15 minutes.)**
15. **Audit Trail:** Enables or Disables the Audit Trail function. When enabled, the VIP will log command activity at this port. To review the command activity log, please refer to Section 17.1.7. **(Default = Off.)**

**Action Parameters:**

16. **Action Delay:** When multiple alarm actions are directed to this port, the action delay determines how much time will elapse between actions. The Action Delay makes it easier to connect to the port, by providing a window when the port is not busy sending out actions. **(Zero to 9999 Seconds; Default = 10 Seconds.)**

**Output Parameters:**

21. **Output Mode:** Selects the data output format for this port; ASCII Record, Binary Block, Xmodem, or ZModem. **(Default = ASCII Record.)**  
**Note:** When using ZModem Output Mode, please refer to the cautions listed in Section 16.7.
22. **Data on ^B01:** If enabled, the VIP will immediately begin sending data when the data release command is invoked (Menu or ^B01). If disabled, the VIP will send the "READY" message, then wait for Command ^B02 before releasing data. **(Default = On.)**
23. **Hold End Data:** At the end of each data release session, the VIP will send the "End Data" message before returning to command mode. When this option is enabled, this port will wait for Command ^B02 before sending the End Data message. **(Default = On.)**

24. **Line Number Tag:** Inserts a Line Number at the beginning of each record or block released by this port. These Line Numbers are not stored in internal memory, but are added when data is released. **(Default = Off.)**
25. **Send Compressed:** When this feature is enabled, data will be released from this port in space compressed format. **(Default = Off.)**
26. **Auto Delete:** When enabled, data will be automatically deleted from the VIP's memory at the end of each successful read. If the read operation is interrupted, data will *not* be deleted. **(Default = Off.)**

**Note:** Before enabling the Auto Delete function, please refer to the cautions listed in Section 16.6.

**Output Parameters (Binary Block Mode Only):**

27. **Transmit Attempts:** (Binary Mode Only) Determines how many times this port will resend a block when there is a transmission problem, or the connection is lost. (Zero to 99 attempts; **Default = 3.**)
28. **Transmit Delay:** (Binary Mode Only) Determines how long this port will wait between transmit attempts. If this value is set to Zero, binary data will be sent in a continuous block, without acknowledgment. (Zero to 99 seconds; **Default = 5 seconds.**)
29. **DLE Stuffing:** (Binary Mode Only) Allows literal characters to be inserted into binary data released by this port. **(Default = Off.)**

```

MODEM PORT:          Modem Installed

COMMUNICATION SETTINGS
1. Baud Rate:        57600
2. Bits/Parity:     8-None
3. Stop Bits:       1
4. Handshake Mode:  RTS/CTS
5. Reset string:    ATZ
6. Init String:     ATE0M0Q1&C1&D2S0
   (Cont.):          =1
7. Hang-up String:  (undefined)
   (Cont.):
8. Reset Modem

GENERAL PARAMETERS
11. Command Echo:   On
12. Response Type:  Inhibit Menu
13. "Sure" Prompt:  On
14. CMD Timeout:    15 Mins
15. Audit Trail:    Off

ACTION PARAMETERS
16. Action Delay:   300 Secs

OUTPUT PARAMETERS
21. Output Mode:    ASCII Record
22. Data on ^B01:   On
23. Hold End Data:  On
24. Line # Tag:     Off
25. Send Compress:  Off
26. Auto Delete:    Off

OUTPUT PARAMETERS (BINARY BLOCK)
27. Transmit Att:   3
28. Transmit Delay: 5 Secs
29. DLE Stuffing:   Off

CALLOUT PARAMETERS
31. Dial Attempts:  3
32. Sequence Att:   3
33. Sequence Delay: 10 Mins
34. Imm Callout:    Off
35. Imm Phone #:    (undefined)
   (Cont.):
36. Dialback Scrtz: On

Enter selection, Press <ESC> to return to previous menu ...

```

Figure 5.8: Modem Port Configuration Menu

#### 5.4.4. Modem Port Configuration

To configure the Modem Port, go to the Port Selector Menu (Main Menu, item 22), and select item 5. The Modem Port Configuration Menu will appear as shown in Figure 5.8. The following options are available:

##### Communication Settings:

1. **Baud Rate:** Selects the baud rate for this port; any standard rate from 1200 to 115.2K bps. (**Default = 57600.**)
2. **Bits/Parity:** Selects Bits/Parity for this port; 8-None, 7-Even, 7-Odd, or 7-None. (**Default = 8-None.**)
3. **Stop Bits:** Selects stop bits for this port. (**Default = 1.**)
4. **Handshake Mode:** Selects the flow control mode for this port; XON/XOFF (Software), RTS/CTS (Hardware), both, or None. (**Default = RTS/CTS.**)
5. **Reset String:** Defines the modem reset message. (Up to 16 characters; **Default = ATZ.**)
6. **Initialize String:** Defines the modem initialization string. (Up to 32 characters; **Default = ATE0M0Q1&C1&D2S0=1.**)
7. **Hang-Up String:** Defines the modem hang-up string. (Up to 32 characters; **Default = undefined.**)
8. **Reset Modem:** Resets the internal modem.

**General Parameters:**

11. **Command Echo:** Enables / disables command echo for this port. During set-up, it may be helpful to enable Command Echo. This allows keystrokes sent to the VIP to be displayed. (**Default = On.**)
12. **Response Type:** Determines how this port will react when command mode is activated. If "Display Menu" is selected, the VIP will immediately display the Main Menu when command mode is activated. If "Inhibit Menu" is selected, the VIP will not display the Main Menu until [**Enter**] is pressed. (**Default = Inhibit Menu.**)
13. **"Sure" Prompt:** When irreversible commands (such as "Erase Data") are invoked at this port, the VIP can display the "Sure" prompt to allow one last chance to verify that the command should be executed. (**Default = On.**)
14. **Command Timeout:** Sets the Timeout value. When no additional command activity is detected at this port during the specified timeout period, the port will exit command mode and disconnect. (**Default =15 minutes.**)
15. **Audit Trail:** Enables or Disables the Audit Trail function. When enabled, the VIP will log command activity at this port. To review the command activity log, please refer to Section 17.1.7. (**Default = Off.**)

**Action Parameters:**

16. **Action Delay:** When multiple alarm actions are directed to this port, the action delay determines how much time will elapse between actions. This makes it easier to connect, by providing a window when the port is not busy sending out actions. (Zero to 9999 Seconds; **Default = 300 Seconds.**)

**Output Parameters:**

21. **Output Mode:** Selects the data output format for this port; ASCII Record, Binary Block, Xmodem or Zmodem. (**Default = ASCII Record.**)

**Note:** When using Zmodem Output Mode, please refer to the cautions listed in Section 16.7.

22. **Data on ^B01:** When enabled, the VIP will immediately begin sending data when the data release command is invoked (Menu or ^B01). When disabled, the VIP will send the "READY" message, then wait for Command ^B02 before releasing data. (**Default = On.**)

23. **Hold End Data:** At the end of each data release session, the VIP will send the "End Data" message before returning to command mode. When this option is enabled, this port will wait for Command ^B02 before sending the End Data message. (**Default = On.**)
24. **Line Number Tag:** Inserts a Line Number at the beginning of each record or block released by this port. These Line Numbers are not stored in internal memory, but are added when data is released. (**Default = Off.**)
25. **Send Compressed:** When this feature is enabled, data will be released from this port in space compressed format. (**Default = Off.**)
26. **Auto Delete:** When enabled, data will be automatically deleted from the VIP's memory at the end of each successful read. If the read is interrupted, data will not be deleted. (**Default = Off.**)

**Note:** Before enabling the Auto Delete function, please refer to the cautions listed in Section 16.6.

#### **Output Parameters (Binary Block Mode Only):**

27. **Transmit Attempts:** (Binary Mode Only) Determines how many times this port will attempt to resend a block when there is a transmission problem, or the connection is lost. (Zero to 99 attempts; **Default = 3.**)
28. **Transmit Delay:** (Binary Mode Only) Determines how long this port will wait between transmit attempts. Note that if this value is set to Zero, binary data will be sent in a continuous block, without acknowledgment. (Zero to 99 seconds; **Default = 5 Seconds.**)
29. **DLE Stuffing:** (Binary Mode Only) Allows literal characters to be inserted into binary data released by this port. (**Default = Off.**)

#### **Callout Parameters:**

31. **Dial Attempts:** The number of times the modem will redial the Callout Number when there is no answer, or the carrier is not received. (Zero to 99 attempts; **Default = 3.**)
32. **Sequence Attempts:** The number of times the modem will restart the callout routine if the defined number of dial attempts is performed and there is no answer, or the carrier is not received. (Zero to 99 attempts; **Default = 3.**)
33. **Sequence Delay:** The amount of time between sequence attempts. (Zero to 999 minutes; **Default = 10 Minutes.**)

34. **Immediate Callout:** Activates the Immediate Callout feature. When enabled, the VIP will dial the Immediate Phone Number after the user disconnects. Note that this feature must be enabled prior to each use, and the Immediate Phone Number must be defined in order for this feature to function. (**Default = Off.**)
35. **Immediate Phone Number:** Defines the number that is dialed when an Immediate Callout is performed. (Up to 32 characters; **Default = undefined.**)
36. **Dialback Security:** Defines and enables dialback security parameters. For more information, please refer to Section 5.4.4.1. (**Default = Off.**)

```
DIALBACK SECURITY:

1. Dialback Security:           On
2. Supervisor Dialback Phone #: (undefined)
3. User Dialback Phone #1:     (undefined)
4. User Dialback Phone #2:     (undefined)

Enter selection,
Press <ESC> to return to previous menu ...
```

Figure 5.9: Dialback Security Configuration Screen

#### 5.4.4.1. Dialback Security

This feature provides an extra measure of security for modem access to command mode. When this option is configured and enabled, the VIP will dial a user-defined number before allowing access to command mode.

If Dialback Security is active, the VIP will display the Password prompt when a user contacts the unit via modem. If the caller enters a valid password, the VIP will then disconnect and call the user-defined number for that password. After successfully contacting the dialback number, the VIP will again display the password prompt. If a valid password is entered by the answering party, the VIP will then allow access to command mode.

The Dialback Security feature will recognize up to three passwords; one Supervisor Password and two User Passwords. The Supervisor password allows access to all configuration menus. The User passwords will not allow access to configuration menus.

To access the Dialback Security menu from the Modem Port Configuration menu, type **36** and press **[Enter]**. The Dialback Security menu (Figure 5.8) offers the following options:

1. **Dialback Security:** Enables/disables the Dialback Security feature. (**Default = Off.**)
2. **Supervisor Dialback Phone Number:** The dialback number that will be used when a caller enters the valid Supervisor Password. (Up to 32 characters; **Default = undefined.**)
3. **User Dialback Phone Number 1:** The dialback number that will be used when a caller enters the User 1 Password. (Up to 32 characters; **Default = undefined.**)
4. **User Dialback Phone Number 2:** The dialback number that will be used when a caller enters the User 2 Password. (Up to 32 characters; **Default = undefined.**)

```

NETWORK PORT:          NIC Installed

COMMUNICATION SETTINGS
1.  IP Address:        65.106.93.105
2.  Subnet Mask:      255.255.255.0
3.  Gateway Addr:    65.106.93.97
4.  SNMP Manager 1:  (undefined)
5.  SNMP Manager 2:  (undefined)
6.  SNMP Community:  public
7.  Reset Network
8.  Send MSS:         1460
9.  Send Email
10. Ping

GENERAL PARAMETERS
11. Command Echo:    On
12. Response Type:  Inhibit Menu
13. "Sure" Prompt:  On
14. CMD Timeout:    15 Mins
15. Audit Trail:    Off

ACTION PARAMETERS
16. Action Delay:   10 Secs
Enter selection, Press <ESC> to return to previous menu ...

OUTPUT PARAMETERS
21. Output Mode:    ASCII Record
22. Data on ^B01:   On
23. Hold End Data:  On
24. Line # Tag:     Off
25. Send Compress:  Off
26. Auto Delete:    On

OUTPUT PARAMETERS (BINARY BLOCK)
27. Transmit Att:   3
28. Transmit Delay: 5 Secs
29. DLE Stuffing:   Off

```

Figure 5.10: Network Configuration Menu

### 5.4.5. Network Port Configuration

Settings for network parameters, such as the IP Address and Subnet Mask, will be determined by your individual network configuration. Please contact your network administrator for appropriate settings, then assign parameters as described in this section.

To configure the Network Port, go to the Port Selector Menu (Main Menu, item 22), and select item 6. The Network Port Configuration Menu (Figure 5.10) offers the following options:

#### Communication Settings:

1. **IP Address:** The VIP's IP Address (**Default = undefined.**)
2. **Subnet Mask:** Defines the VIP's subnet mask. (**Default = 255.255.255.0.**)
3. **Gateway Address:** Defines the VIP's Gateway Address. (**Default = undefined.**)
4. **SNMP Manager 1:** Defines the IP Address for the first SNMP Manager. The VIP allows definition of two SNMP Managers. (**Default = undefined.**)
5. **SNMP Manager 2:** Defines the IP Address for the second SNMP Manager. (**Default = undefined.**)
6. **SNMP Community:** Defines the SNMP Community. (**Default = public.**)
7. **Reset Network:** Reinitializes the network port.



8. **Send MSS:** Sets the Maximum Segment Size for TCP/IP packets sent by the VIP. (**Default = 1460.**)
9. **Send Email:** This item is used to define parameters that are employed when the VIP automatically generates an email or text message in order to notify the operator that an alarm has been detected. Note that these same parameters are also used when the "Scheduled Actions" feature is configured to send email or text messages. Email parameters are described further in Section 5.4.5.1.
10. **Ping:** This feature can be used to determine if a given piece of remote network hardware is online and is able to communicate with the VIP unit. For more information, please refer to Section 5.4.5.2

#### **General Parameters:**

11. **Command Echo:** Enables / Disables the command echo for this port. During set-up, it may be helpful to enable Command Echo. This allows keystrokes sent to the VIP to be displayed on your monitor. (**Default = On.**)
12. **Response Type:** Determines how this port will react when command mode is activated. If "Display Menu" is selected, the VIP will immediately display the Main Menu when command mode is activated. If "Inhibit Menu" is selected, the VIP will not display the Main Menu until [Enter] is pressed. (**Default = Inhibit Menu.**)
13. **"Sure" Prompt:** When irreversible commands (such as "Erase Data") are invoked, this port can display the "Sure" prompt to allow one last chance to verify that the command should be executed. (**Default = On.**)
14. **Command Timeout:** Sets the Timeout value. If no additional command activity is detected at this port during the defined timeout period, this port will exit command mode and disconnect. (**Default =15 minutes.**)
15. **Audit Trail:** Enables or Disables the Audit Trail function. When enabled, the VIP will log command activity at this port. To review the command activity log, please refer to Section 17.1.7. (**Default = Off.**)

#### **Action Parameters:**

16. **Action Delay:** When multiple alarm actions are directed to this port, the action delay determines how much time will elapse between actions. This makes it easier to connect to the port, by providing a window when the port is not busy sending out actions. (Zero to 9999 Seconds; **Default = 10 Seconds.**)

**Output Parameters:**

21. **Output Mode:** Selects the data output format for this port; ASCII Record, Binary Block, Xmodem or Zmodem.  
(**Default = ASCII Record.**)  
**Note:** When using Zmodem Output Mode, please refer to the cautions listed in Section 16.7.
22. **Data on ^B01:** When enabled, the VIP will immediately begin sending data when the data release command is invoked (Menu or ^B01). When disabled, the VIP will send the "READY" message, then wait for Command ^B02 before releasing data. (**Default = On.**)
23. **Hold End Data:** At the end of each data release session, the VIP will send the "End Data" message before returning to command mode. When "Hold End Data" is enabled, this port will wait for Command ^B02 before sending the End Data message. (**Default = On.**)
24. **Line Number Tag:** Inserts a Line Number at the beginning of each record or block released by this port. These Line Numbers are not stored in the VIP's internal memory, but are added when data is released. (**Default = Off.**)
25. **Send Compressed:** When this feature is enabled, data will be released from this port in space compressed format. (**Default = Off.**)
26. **Auto Delete:** When enabled, data will be automatically deleted from the VIP's memory at the end of each successful read. If the read is interrupted, data will *not* be deleted. (**Default = Off.**)  
**Note:** Before enabling the Auto Delete function, please refer to the cautions listed in Section 16.6.

**Output Parameters (Binary Block Mode Only):**

27. **Transmit Attempts:** (Binary Mode Only) Determines how many times this port will resend a block after a transmission interruption, or lost connection. (Zero to 99 attempts; **Default = 3.**)
28. **Transmit Delay:** (Binary Mode Only) Determines how long this port will wait between transmit attempts. If this value is set to Zero, binary data will be sent in a continuous block, without acknowledgment. (Zero to 99 seconds; **Default = 5 seconds.**)
29. **DLE Stuffing:** (Binary Mode Only) Allows literal characters to be inserted into binary data released by this port. (**Default = Off.**)

```

SEND EMAIL:

SMTP SERVER PARAMETERS
1. IP Address:      (undefined)
2. Port Number:    25
3. User Name:      (undefined)
   (Cont.):
   (Cont.):
4. Password:       (undefined)
5. Auth Type:      LOGIN

EMAIL PARAMETERS
21. From Name:     (undefined)
22. From Address:  (undefined)
   (Cont.):
   (Cont.):
23. To Name #1:    (undefined)
24. To Address #1: (undefined)
   (Cont.):
   (Cont.):
25. To Name #2:    (undefined)
26. To Address #2: (undefined)
   (Cont.):
   (Cont.):
27. Priority:      Normal
28. Subject:       (undefined)
   (Cont.):
   (Cont.):

MISCELLANEOUS
11. Send Test Email
12. Stop Email Sess
13. Last Email Stat

Enter selection,
Press <ESC> to return to previous menu ...

```

Figure 5.11: The Send Email Configuration Menu

#### 5.4.5.1. The Email & Text Messaging Parameters Menu

When an alarm or scheduled event occurs, the VIP can notify you via pager, callout, SNMP Trap, Console Port Action, Email or Text Message.

Configuring the Email option consists of two steps: Selecting Email Parameters (communication parameters and email addresses) and then enabling the Email option for the desired alarm filters and scheduled events. The procedure for defining email and text message parameters is discussed below, and the procedure for enabling email and text messaging for specific alarms and scheduled events is discussed in Sections 13 and 14.

To access the email configuration menu from the Network Port Parameters menu, type **9** and press **[Enter]**. The "Send Email" parameters menu (Figure 5.11) can be used to define the following parameters.

#### SMTP Server Parameters

1. **IP Address:** The IP Address for your SMTP Email Server. **(Default = undefined.)**
2. **Port Number:** The TCP Port number that is used when sending email or text messages. The port number can be any valid port, from 1 to 65535, but cannot be a Telnet port, FTP port, HTTP port, or the PBX-IP Port. **(Default = 25.)**
3. **User Name:** The username that is normally entered when logging on to your SMTP Server. **(Default = undefined.)**
4. **Password:** The password that is normally entered when logging on to your SMTP Server. **(Default = undefined.)**

5. **Auth Type:** The type of authentication that is used when logging onto your SMTP Server. **(Default = Login.)**

**Miscellaneous:**

11. **Send Test Email:** Sends a test email or text message, based on the currently defined email parameters.
12. **Stop Email Session:** Cancels any email action currently in progress.
13. **Last Email Stat:** Lists the current status of the last email sent.

**Email Parameters:**

21. **From Name:** When an email or text message is sent, this name will appear in the "From" field. **(Default = undefined.)**
22. **From Address:** When an email or text message is sent, this address will appear in the "From Address" field. **(Default = undefined.)**
23. **To Name #1:** Defines the name for the first optional email or text message recipient. When email parameters are properly defined, the "Email To" option in the Alarm Configuration Menus and Scheduled Action Menus can be used to select Name Number One to receive an email or text message when an alarm action or scheduled action is generated. **(Default = undefined.)**
24. **To Address #1:** Defines the email address for Name Number One. When email parameters are properly defined, the "Email To" option in the Alarm Configuration Menus and Scheduled Action Menus can be used to select Name Number One to receive an email or text message when an Alarm Action or Scheduled Action is generated. **(Default = undefined.)**
25. **To Name #2:** Defines the name for the second optional email or text message recipient. **(Default = undefined.)**
26. **To Address #2:** Defines the email address for Name Number Two. **(Default = undefined.)**
27. **Priority:** Defines the priority assigned to email generated when the "Email To" option is selected as an Alarm Action or Scheduled Action. **(Default = Normal.)**
28. **Subject:** Defines the subject line for email or text messages generated when the "Email To" option is selected as an Alarm Action or Scheduled Action. **(Default = undefined.)**

```
PING:

GENERAL PARAMETERS
1. IP Address:      (undefined)
2. Send Pkts:      4
3. Con. Lost Pkts: 4
4. Response Delay: 1 Sec
5. Pkt Delay:      1 Sec
6. Pkt Size:       32

MISCELLANEOUS
11. Start Ping
12. Stop Ping Sess
13. Last Ping Stat

Enter selection,
Press <ESC> to return to previous menu ...
```

Figure 5.12: The Ping Configuration Menu

### 5.4.5.2 The Ping Function

The VIP's Network Port Configuration Menu includes a Ping function, which can be used to determine if a given piece of remote network hardware is online and able to communicate with the VIP.

The Ping Configuration Menu (Figure 5.12) offers the following options:

1. **IP Address:** The IP Address for the device that you wish to ping. **(Default = undefined.)**
2. **Send Pkts:** The number of ping packets that will be sent. **(Default = 4.)**
3. **Con. Lost Pkts:** The number of consecutive lost packets. **(Default = 4.)**
4. **Response Delay:** **(Default = 1 second.)**
5. **Packet Delay:** **(Default = 1 second.)**
6. **Packet Size:** **(Default = 32.)**

#### Miscellaneous:

11. **Start Ping:** Starts the ping session based on the currently defined parameters.
12. **Stop Ping Session:** Stops the current Ping Session.
13. **Last Ping Stat:** Displays the statistics/results for the most recent ping session.

```

PBX IP PORT:

COMMUNICATION SETTINGS
1. Service: On
2. Port Number: 9000
3. Window Size: 6
4. Keep Alive Send: 60 Secs
5. Keep Alive Resp: 60 Secs
6. SDM Resp: 30 Secs

MISCELLANEOUS
21. Disconnect
22. Last Status

INPUT PARAMETERS
11. Time/Date Stmp: Off
12. Serial No Stmp: Off
13. Strip Non-Prnt: On
14. End Character: ^J
15. Alarm Filter: Off
16. Store Alm Data: Alarm
17. Data Filter: Off
18. PBX Inact Alm: Off

FIELD SUPPRESSION
31. Lucent Switch

Enter selection,
Press <ESC> to return to previous menu ...
    
```

Figure 5.13: The PBX IP Port Configuration Menu

### 5.4.6. PBX IP Port Configuration

The PBX IP Port allows the VIP to collect data via network connection, from an RSP compatible PBX, such as an Avaya PBX Switch. To configure the PBX IP Port, first go to the Port Configuration Menu (Main Menu, Item 22.) Type **7** and press **[Enter]**. The menu shown in Figure 5.13 will be displayed. The following options are available:

#### Notes:

- In most cases, the only configuration required, is to enable the PBX IP Service and select the Port Number. The default settings for the other parameters in the PBX IP Port Configuration menu will generally function in most network environments.
- The proper settings for the "Window Size," "Keep Alive Send," "Keep Alive Resp." and "SDM Resp" parameters are determined by the nature of your network environment.
- If an asterisk (\*) appears next to a menu item, this indicates that the change cannot be implemented until later. For example, an asterisk will appear next to the Port Number if that Port Number is already in use.

#### Communication Settings:

1. **Service:** Enables/Disables the PBX IP Port. In order for the VIP to receive PBX data via network, this item must be "On."  
(Default = On.)
2. **Port Number:** The RSP Port Number. Cannot be a Telnet Port, FTP Port, SMTP Port or HTTP Port. (From 1 to 65535; Default = 9000.)
3. **Window Size:** The RSP Window Size. (From 1 to 255; Default = 6.)

4. **Keep Alive Send:** The "keep alive send" timeout in seconds. (From 1 to 3600; **Default = 60 Seconds.**)
5. **Keep Alive Response:** The "keep alive response" timeout in seconds. (From 1 to 3600; **Default = 60 Seconds.**)
6. **SDM Response:** The session disconnect message response timeout in seconds. (From 1 to 3600; **Default = 30 Seconds.**)

**Input Parameters:**

11. **Time/Date Stamp:** The date stamp can be inserted at the beginning of each record received by this port. This prompt is used to disable the function, or select the short format or long format. The short format (PollCat III Compatible) lists Month, Date, Hour and Minute; the long format lists Month, Date, Year, Hour, Minute, and Second. (**Default = Off.**)
12. **Serial Number Stamp:** Inserts a six digit number at the beginning of each record received by this port. (**Default = Off.**)
13. **Strip Non-Printables:** Conserves memory by excluding characters such as Nuls and Dels. (**Default = On.**)
14. **End Character:** Defines the End-of-Record (EOR) character that the VIP will expect to see at the end of each record received at this port. (**Default = ^J (Line Feed).**)
15. **Alarm Filter:** Enables/disables the Alarm Filter and selects the Alarm Filter Format that will be used by this port. The Alarm Filter monitors data and provides notification when specific types of data are detected. For more information, please refer to Section 9. (**Default = Off.**)
16. **Store Alarm Data:** Determines where the VIP will store alarm data received via this port. Alarm Records can be stored in the Alarm File, the Standard (non-alarm) File, or both files. For more information, please refer to Section 16.1.1. (**Default = Both.**)

17. **Data Filter:** Enables/disables the Data Filter, and selects the Data Filter Format that will be used by this port. The Data Filter conserves memory and cuts polling time by excluding records not needed for your application. For more information, please refer to Section 8. **(Default = Off.)**
18. **PBX Inactivity Alarm:** Enables/disables the PBX Inactivity Alarm and selects the format for this port. The inactivity alarm monitors the flow of data from the PBX and provides notification if the flow stops. For further instructions, please refer to Section 10. **(Default = Off.)**

**Miscellaneous:**

21. **Disconnect:** Terminates the connection to the RSP server.
22. **Last Status:** Displays the current status of the RSP connection.

**Field Suppression:**

31. **Lucent Switch:** This Item can be used to suppress the phone number field in certain data records, as described in Section 5.4.1.1. This feature is useful in countries that prohibit the transfer of phone number records via network.



## 6. Menu System Description

The VIP operating system features a series of menus, which are used to select options, invoke commands, and review status. This section provides an overview of the VIP operating system, in order to help you locate specific items in the various submenus.

### 6.1. Firmware Tree

Command functions are accessed via the Main Menu, which is the first screen displayed when command mode is activated. The Main Menu branches off into a series of submenus. Each submenu is dedicated to a specific task, such as port configuration, buffer management, etc. To access a submenu, type the number for the desired item and press [Enter].

Main Menu Item	Submenu(s)/Function(s)
1. Status Displays	Display Status Screens for user-defined parameters, memory usage, and alarm conditions (See Section 7.)
2. Buffer Functions	<ol style="list-style-type: none"><li>1. Set Read Session Parameters</li><li>2. Set Partition</li><li>3. Release Partition</li><li>4. Enter Read Session</li><li>5. Erase Partition Data</li><li>6. Erase All Data</li><li>7. Erase All Data &amp; Clear Alarm Counters</li><li>8. Release Remote Partition</li></ol>
3. System Functions	<ol style="list-style-type: none"><li>1. Security Level</li><li>2. PassThrough Mode</li><li>3. Monitor Mode</li><li>4. Clear Alarm Condition</li><li>5. Clear Alarm Clue Counters</li><li>6. Download Parameters</li><li>7. Audit Trail Functions</li><li>8. Upload Firmware</li></ol>
4. System Diagnostics	<ol style="list-style-type: none"><li>1. Load &amp; Test Memory</li><li>2. Send Test Message</li><li>3. Test Pager</li><li>4. Send Test SNMP Trap(s)</li></ol>
5. ^Bxx Command Help	Lists all ^Bxx format (manually entered) commands. (See Section 19). "A" option allows access to menu with additional command help.
6. Recall Parameters	Restores previously saved parameters.
7. Save Operating Parameters	Writes user-defined parameters from temporary memory to flash memory.
8. Exit Command Mode	Exits from command mode, disconnects, and puts Console Port to sleep.
9. - 20.	Reserved for Future Use.

Main Menu Item	Submenu(s)/Function(s)	
21. Default Parameters	Resets all parameters to default settings. Offers the option to include or exclude network parameters and Alarm Filter and Data Filter configurations.	
22. Port Configuration	1. <b>PBX Port A</b>	<p><b>Communication Settings</b></p> <ol style="list-style-type: none"> <li>1. Baud Rate</li> <li>2. Bits/Parity</li> <li>3. Stop Bits</li> <li>4. Handshake Mode</li> </ol> <p><b>Input Parameters</b></p> <ol style="list-style-type: none"> <li>11. Time Date Stamp</li> <li>12. Serial Number Stamp</li> <li>13. Strip Non-Printable Characters</li> <li>14. End Character</li> <li>15. Alarm Filter</li> <li>16. Store Alarm Data</li> <li>17. Data Filter</li> <li>18. PBX Inactivity Alarm</li> </ol> <p><b>Field Suppression</b></p> <ol style="list-style-type: none"> <li>31. Lucent Switch</li> </ol>
	2. <b>PBX Port B</b> (Note: Not included on NLJ-VIP units.)	<p><b>Communication Settings</b></p> <ol style="list-style-type: none"> <li>1. Baud Rate</li> <li>2. Bits/Parity</li> <li>3. Stop Bits</li> <li>4. Handshake Mode</li> </ol> <p><b>Input Parameters</b></p> <ol style="list-style-type: none"> <li>11. Time Date Stamp</li> <li>12. Serial Number Stamp</li> <li>13. Strip Non-Printable Characters</li> <li>14. End Character</li> <li>15. Alarm Filter</li> <li>16. Store Alarm Data</li> <li>17. Data Filter</li> <li>18. PBX Inactivity Alarm</li> </ol> <p><b>Field Suppression</b></p> <ol style="list-style-type: none"> <li>31. Lucent Switch</li> </ol>
	3. <b>Auxiliary Port</b> (Note: Not included on NLJ-VIP units.)	<p><b>Communication Settings</b></p> <ol style="list-style-type: none"> <li>1. Baud Rate</li> <li>2. Bits/Parity</li> <li>3. Stop Bits</li> <li>4. Handshake Mode</li> </ol> <p><b>Input Parameters</b></p> <ol style="list-style-type: none"> <li>11. Time Date Stamp</li> <li>12. Serial Number Stamp</li> <li>13. Strip Non-Printable Characters</li> <li>14. End Character</li> <li>15. Alarm Filter</li> <li>16. Store Alarm Data</li> <li>17. Data Filter</li> <li>18. PBX Inactivity Alarm</li> <li>19. Port Mode</li> </ol> <p><b>Field Suppression</b></p> <ol style="list-style-type: none"> <li>31. Lucent Switch</li> </ol>

Main Menu Item	Submenu(s)/Function(s)	
22. Port Configuration (Continued)	4. Console Port	<p><b>Communication Settings</b></p> <ol style="list-style-type: none"> <li>1. Baud Rate</li> <li>2. Bits/Parity</li> <li>3. Stop Bits</li> <li>4. Handshake Mode</li> </ol> <p><b>General Parameters</b></p> <ol style="list-style-type: none"> <li>11. Command Echo</li> <li>12. Response Type</li> <li>13. "Sure" Prompt</li> <li>14. Command Timeout</li> <li>15. Audit Trail</li> </ol> <p><b>Action Parameters</b></p> <ol style="list-style-type: none"> <li>16. Action Delay</li> </ol> <p><b>Output Parameters</b></p> <ol style="list-style-type: none"> <li>21. Output Mode</li> <li>22. Data on ^B01</li> <li>23. Hold End Data</li> <li>24. Line Number Tag</li> <li>25. Send Compressed</li> <li>26. Auto Delete</li> </ol> <p><b>Output Params. (Binary Block)</b></p> <ol style="list-style-type: none"> <li>27. Transmit Attempts</li> <li>28. Transmit Delay</li> <li>29. DLE Stuffing</li> </ol>
	5. Modem Port	<p><b>Communication Settings</b></p> <ol style="list-style-type: none"> <li>1. Baud Rate</li> <li>2. Bits/Parity</li> <li>3. Stop Bits</li> <li>4. Handshake Mode</li> <li>5. Reset String</li> <li>6. Initialize String</li> <li>7. Hang-Up String</li> <li>8. Reset Modem</li> </ol> <p><b>General Parameters</b></p> <ol style="list-style-type: none"> <li>11. Command Echo</li> <li>12. Response Type</li> <li>13. "Sure" Prompt</li> <li>14. Command Timeout</li> <li>15. Audit Trail</li> </ol> <p><b>Action Parameters</b></p> <ol style="list-style-type: none"> <li>16. Action Delay</li> </ol> <p><b>Output Parameters</b></p> <ol style="list-style-type: none"> <li>21. Output Mode</li> <li>22. Data on ^B01</li> <li>23. Hold End Data</li> <li>24. Line Number Tag</li> <li>25. Send Compressed</li> <li>26. Auto Delete</li> </ol> <p><b>Output Params. (Binary Block)</b></p> <ol style="list-style-type: none"> <li>27. Transmit Attempts</li> <li>28. Transmit Delay</li> <li>29. DLE Stuffing</li> </ol> <p><b>Callout Parameters</b></p> <ol style="list-style-type: none"> <li>31. Dial Attempts</li> <li>32. Sequence Attempts</li> <li>33. Sequence Delay</li> <li>34. Immediate Callout</li> <li>35. Immediate Phone Number</li> <li>36. Dialback Security</li> </ol>

Main Menu Item	Submenu(s)/Function(s)	
<p>22. Port Configuration (Continued)</p>	<p>6. Network Port</p>	<p><b>Communication Settings</b></p> <ol style="list-style-type: none"> <li>1. IP Address</li> <li>2. Subnet Mask</li> <li>3. Gateway Address</li> <li>4. SNMP Manager 1</li> <li>5. SNMP Manager 2</li> <li>6. SNMP Community</li> <li>7. Reset Network Port</li> <li>8. Send MSS</li> <li>9. Send Email</li> <li>10. Ping</li> </ol> <p><b>General Parameters</b></p> <ol style="list-style-type: none"> <li>11. Command Echo</li> <li>12. Response Type</li> <li>13. "Sure" Prompt</li> <li>14. Command Timeout</li> <li>15. Audit Trail</li> </ol> <p><b>Action Parameters</b></p> <ol style="list-style-type: none"> <li>16. Action Delay</li> </ol> <p><b>Output Parameters</b></p> <ol style="list-style-type: none"> <li>21. Output Mode</li> <li>22. Data on ^B01</li> <li>23. Hold End Data</li> <li>24. Line Number Tag</li> <li>25. Send Compressed</li> <li>26. Auto Delete</li> </ol> <p><b>Output Parameters (Binary Block)</b></p> <ol style="list-style-type: none"> <li>27. Transmit Attempts</li> <li>28. Transmit Delay</li> <li>29. DLE Stuffing</li> </ol>
	<p>7. PBX IP Port</p>	<p><b>Communication Settings</b></p> <ol style="list-style-type: none"> <li>1. Service</li> <li>2. Port Number</li> <li>3. Window Size</li> <li>4. Keep Alive Send</li> <li>5. Keep Alive Response</li> <li>6. SDM Response</li> </ol> <p><b>Input Parameters</b></p> <ol style="list-style-type: none"> <li>11. Time/Date Stamp</li> <li>12. Serial Number Stamp</li> <li>13. Strip Non-Printables</li> <li>14. End Character</li> <li>15. Alarm Filter</li> <li>16. Store Alarm Data</li> <li>17. Data Filter</li> <li>18. PBX Inactivity Alarm</li> </ol> <p><b>Miscellaneous</b></p> <ol style="list-style-type: none"> <li>21. Disconnect</li> <li>22. Last Status</li> </ol> <p><b>Field Suppression</b></p> <ol style="list-style-type: none"> <li>31. Lucent Switch</li> </ol>

Main Menu Item	Submenu(s)/Function(s)	
23. System Parameters	<ol style="list-style-type: none"> <li>1. Supervisor Password</li> <li>2. User Password 1</li> <li>3. User Password 2</li> <li>4. Site ID Message</li> <li>5. Wrap-Around</li> <li>6. Real Time Clock</li> <li>7. Alarm Data Wrap-Around</li> </ol>	
24. Scheduled Action Parameters	1. <b>Scheduled Action #1</b>	<p><b>Schedule</b></p> <ol style="list-style-type: none"> <li>1. Schedule Action (On/Off)</li> <li>2-8. Define Schedule</li> </ol> <p><b>Exclusions (MM/DD)</b></p> <ol style="list-style-type: none"> <li>9. Add Exclusion</li> <li>10. Delete Exclusion</li> </ol> <p><b>Action Parameters</b></p> <ol style="list-style-type: none"> <li>11. Action</li> <li>12. Phone Number</li> <li>13. Pager ID 1</li> <li>14. Pager ID 2</li> <li>15. Pager ID 3</li> <li>16. SNMP Management</li> <li>17. Output Contacts</li> <li>18. Message</li> <li>19. Auto Execute</li> <li>20. Execute Commands</li> <li>21. Email To</li> </ol>
	2. <b>Scheduled Action #2</b>	<p><b>Schedule</b></p> <ol style="list-style-type: none"> <li>1. Schedule Action (On/Off)</li> <li>2-8. Define Schedule</li> </ol> <p><b>Exclusions (MM/DD)</b></p> <ol style="list-style-type: none"> <li>9. Add Exclusion</li> <li>10. Delete Exclusion</li> </ol> <p><b>Action Parameters</b></p> <ol style="list-style-type: none"> <li>11. Action</li> <li>12. Phone Number</li> <li>13. Pager ID 1</li> <li>14. Pager ID 2</li> <li>15. Pager ID 3</li> <li>16. SNMP Management</li> <li>17. Output Contacts</li> <li>18. Message</li> <li>19. Auto Execute</li> <li>20. Execute Commands</li> <li>21. Email To</li> </ol>
25. Alarm Configuration	1. <b>Alarm Filter 1</b>	<ol style="list-style-type: none"> <li>1. Define Format</li> <li>2. Display Clue Details</li> <li>3. Define Clues</li> <li>4. Edit Clues</li> <li>5. Delete Clues</li> <li>6. Alarm Counter Reset Time</li> </ol>

Main Menu Item	Submenu(s)/Function(s)	
<b>25. Alarm Configuration (Continued)</b>	<b>2. Alarm Filter 2</b>	<ol style="list-style-type: none"> <li>1. Define Format</li> <li>2. Display Clue Details</li> <li>3. Define Clues</li> <li>4. Edit Clues</li> <li>5. Delete Clues</li> <li>6. Alarm Counter Reset Time</li> </ol>
	<b>3. PBX Inactivity Alarm 1</b>	<p><b>Schedule</b></p> <ol style="list-style-type: none"> <li>1. Weekday Alarm (On/Off)</li> <li>2-5. Weekday Schedules &amp; Timers</li> <li>6. Weekend Alarm (On/Off)</li> <li>7-10. Weekend Schedules &amp; Timers</li> </ol> <p><b>Exclusions (MM/DD)</b></p> <ol style="list-style-type: none"> <li>11. Add Exclusion</li> <li>12. Delete Exclusion</li> </ol> <p><b>Alarm Action Parameters</b></p> <ol style="list-style-type: none"> <li>13. Action</li> <li>14. Phone Number</li> <li>15. Pager ID 1</li> <li>16. Pager ID 2</li> <li>17. Pager ID 3</li> <li>18. SNMP Management</li> <li>19. Output Contacts</li> <li>20. Message</li> <li>21. Auto Execute</li> <li>22. Execute Commands</li> <li>23. Email To</li> </ol>
	<b>4. PBX Inactivity Alarm 2</b>	<p><b>Schedule</b></p> <ol style="list-style-type: none"> <li>1. Weekday Alarm</li> <li>2-5. Weekday Schedules &amp; Timers</li> <li>6. Weekend Alarm</li> <li>7-10. Weekend Schedules &amp; Timers</li> </ol> <p><b>Exclusions (MM/DD)</b></p> <ol style="list-style-type: none"> <li>11. Add Exclusion</li> <li>12. Delete Exclusion</li> </ol> <p><b>Alarm Action Parameters</b></p> <ol style="list-style-type: none"> <li>13. Action</li> <li>14. Phone Number</li> <li>15. Pager ID 1</li> <li>16. Pager ID 2</li> <li>17. Pager ID 3</li> <li>18. SNMP Management</li> <li>19. Output Contacts</li> <li>20. Message</li> <li>21. Auto Execute</li> <li>22. Execute Commands</li> </ol>

Main Menu Item	Submenu(s)/Function(s)	
<b>25. Alarm Configuration (Continued)</b>	<b>5. 80% Full Alarm</b>	<ol style="list-style-type: none"> <li>1. 80% Full Alarm</li> <li>2. Action</li> <li>3. Phone Number</li> <li>4. Pager ID 1</li> <li>5. Pager ID 2</li> <li>6. Pager ID 3</li> <li>7. SNMP Management</li> <li>8. Output Contacts</li> <li>9. Message</li> <li>10. Auto Execute</li> <li>11. Execute Commands</li> <li>12. Email To</li> </ol>
	<b>6. Input Contact Alarm</b> (Optional: Not available on NLJ-VIP)	<ol style="list-style-type: none"> <li>1. Input Contact 1 Alarm</li> <li>2. Input Contact 2 Alarm</li> <li>3. Input Contact 3 Alarm</li> <li>4. Input Contact 4 Alarm</li> </ol>
	<b>Output Contacts (Idle/No Alarm)</b> (Optional: Not Available on NLJ-VIP) <ol style="list-style-type: none"> <li>7. Contacts 1/2/3/4</li> </ol>	
	<b>Default Alarm Action Parameters</b> <ol style="list-style-type: none"> <li>8. Action</li> <li>9. Phone Number</li> <li>10. Pager ID 1</li> <li>11. Pager ID 2</li> <li>12. Pager ID 3</li> <li>13. SNMP Management</li> <li>14. Output Contacts 1/2/3/4</li> <li>15. Message</li> <li>16. Auto Execute</li> <li>17. Execute Commands</li> <li>18. Send Alarm Records</li> <li>19. Email To</li> </ol>	
<b>26. Data Filter Configuration</b>	<b>1. Data Filter 1</b>	<ol style="list-style-type: none"> <li>1. Data Filter Action</li> <li>2. Define Format</li> <li>3. Display Clue Details</li> <li>4. Define Clues</li> <li>5. Edit Clues</li> <li>6. Delete Clues</li> </ol>
	<b>2. Data Filter 2</b>	<ol style="list-style-type: none"> <li>1. Data Filter Action</li> <li>2. Define Format</li> <li>3. Display Clue Details</li> <li>4. Define Clues</li> <li>5. Edit Clues</li> <li>6. Delete Clues</li> </ol>

<b>Main Menu Item</b>	<b>Submenu(s)/Function(s)</b>
<b>27. FTP Push Configuration</b>	<b>FTP Server Parameters</b> 1. Server Address 2. User Name 3. Password 4. Account 5. Directory 6. File Name 7. File Mode 8. File Extension Incrementing <b>Action Parameters</b> 11. Read Session 12. Push Action 13. Periodic Push 14. Transmit Attempts 15. Transmit Delay 16. Auto Delete 17. FTP Push Start Time <b>Miscellaneous</b> 21. Force FTP Push 22. Test FTP Push 23. Stop FTP Push
<b>28. FTP Server Configuration</b>	<b>FTP Server Parameters</b> 1. User Name 2. Password 3. Filename 4. Auto Delete 5. Audit Trail <b>Miscellaneous</b> 11. Stop FTP Session



## 7. Status Screens

---

The VIP includes a series of Status Screens that list the current state of all program features and options.

During normal operation, these screens are used to check memory conditions, review alarm status, and display the standing of the VIP options and parameters. The Status Screens are also helpful during Setup and configuration; allowing the user to determine if parameters need to be changed.

This section summarizes the VIP's various Status Screens, and explains individual items in each screen. To access the Status Screens, go to the Main Menu, type **1** and press **[Enter]**. The VIP will display the screen shown in Figure 7.1 below.

```
STATUS DISPLAYS:

1.  Buffer Status                21. PBX Port A
2.  File List                   22. PBX Port B
3.  System Status              23. AUX Port
4.  Scheduled Action 1         24. Console Port
5.  Scheduled Action 2         25. Modem Port
6.  Dialback Security          26. Network Port
7.  Data Filters & Alarms      27. Network Status
8.  Alarm Condition            28. PBX IP Port

11. PBX Inactivity Alarm 1     31. Alarm Filter 1 Clue Status (PBX-A)
12. PBX Inactivity Alarm 2     32. Alarm Filter 2 Clue Status (PBX-A)
13. 80% Full Alarm             33. Alarm Filter 1 Clue Status (PBX-B)
14. Input Contact Alarm        34. Alarm Filter 2 Clue Status (PBX-B)
15. Reason For Action          35. Alarm Filter 1 Clue Status (AUX)
                                36. Alarm Filter 2 Clue Status (AUX)
                                37. Alarm Filter 1 Clue Status (PBX IP)
                                38. Alarm Filter 2 Clue Status (PBX IP)

Enter selection,
Press <ESC> to return to previous menu ...
```

Figure 7.1: Status Display Menu

```
PollCat NetLink-VIP      Version 1.06      11/08/2005 Tue 11:29  1% Full
BUFFER STATUS:

Unit Capacity:          16 MB
Space Used:             16 KB
Space Remaining:       15 MB
Percent Full:           1%
Total Record Ct:       44

PARTITION RECORD COUNT
Console Port:           None
Modem Port:             None
Telnet Port #1:         None
Telnet Port #2:         None
Telnet Port #3:         None
FTP Push:               None
FTP Server:             None

Press <Enter> to return to menu ...
```

Figure 7.2: Buffer Status Screen

## 7.1. Buffer Status Screen

As shown in Figure 7.2, the Buffer Status screen lists current memory conditions, including the following items:

- **Unit Capacity:** The total amount of internal flash memory.
- **Space Used:** The approximate amount of memory currently in use.
- **Space Remaining:** The approximate amount of free memory.
- **Percent Full:** The approximate percentage of memory currently in use.
- **Total Record Count:** The total number of records stored.
- **Partition Record Count:** The number of records in the partitions for the Console Port, Modem Port, Telnet Ports, and the FTP functions. When data is released, each command port or FTP function is temporarily designated as "owner" of a specific type of record (see Section 16). For example, the Console port may own all records received via PBX Port A, or the Modem Port may own all records for Alarm Filter 1.
  - **Console Port:** The number of records in the partition owned by the Console Port.
  - **Modem Port:** The number of records in the partition owned by the Modem Port.
  - **Telnet Ports 1 to 3:** The number of records in the partitions owned by each Telnet port.
  - **FTP Push and FTP Server:** The number of records in the partitions owned by each FTP function.

PollCat NetLink-VIP		Version 1.06	11/08/2005 Tue 11:31		1% Full
FILE LIST:					
Port	Data Type	Total Record Ct	Partition Record Ct	Partition Owner	
-----					
PBX-A	Standard	44	0	None	
Press <Enter> to return to menu ...					

Figure 7.3: File List (Sample Values Shown)

## 7.2. File List Screen

As shown in Figure 7.3, this screen shows a breakdown of the types of records stored in buffer memory. Records are listed according to Data Type and Receiving Port. There are three Data Types; Standard (Non-Alarm), Alarm Filter 1, and Alarm Filter 2. There are three Receiving Ports; PBX Port A, PBX Port B, and the AUX Port. When Data Type and Receiving Port are combined, this provides nine possible file types. For more information, please refer to Section 16.1.1.

The File List includes the following information:

- **Port:** The Input Port (A, B, AUX) that received the records.
- **Data Type:** The type of record is listed as follows:
  - **Standard:** (Non-Alarm) Records that did not match an Alarm Clue.
  - **Alarm Filter 1:** Records that match any Clue from Alarm Filter 1.
  - **Alarm Filter 2:** Records that match any Clue from Alarm Filter 2.
- **Total Record Count:** The total number of records of this type, including records that may have been stored outside of the current partition after the partition was set.
- **Partition Record Count:** The number of records in this partition.
- **Partition Owner:** The name of the command port (Console Port, Modem Port, or Net Port) or FTP Function that owns the partition for this type of record. When data is released, each command port or FTP Function is temporarily designated as "owner" of a specific type of record. For example, the Console port may own all records received via PBX Port A, or the Modem Port may own all records that match a clue for Alarm Filter 1.

```

PollCat NetLink-VIP   Version 1.06   11/08/2005 Tue 11:33  1% Full
SYSTEM STATUS:

MEMORY CONFIGURATION                               SYSTEM PARAMETERS
Module #1:           16 MB                          Spvsr Password:   (...)
Module #2:           Not installed                  User Password 1:  SMDR
Module #3:           Not installed                  User Password 2:  (undefined)
Module #4:           Not installed                  Site ID Msg:      (undefined)
Base Memory:         Not used                       (Cont.):
Unit Capacity:       16 MB                          Wrap-Around:      Off
                                                         Alm Data Wrap-Arnd: Off

COMMUNICATION SETTINGS                             DIP SWITCH SETTINGS
PBX Port A:          9600,E,7,1,None                SW-1 SW-2 SW-3 SW-4 SW-5 SW-6 SW-7 SW-8
PBX Port B:          9600,E,7,1,None                Down Down Down Down Down Down Up  Down
Auxiliary Port:      9600,E,7,1,None
Console Port:        9600,N,8,1,RTS
Modem Port:          57600,N,8,1,RTS

COMMAND PORT STATUS:                               NETWORK PORT STATUS:
Console Port:        Off Line                       Telnet Port #1:   On Line
Modem Port:          Off Line                       Telnet Port #2:   Off Line
                                                         Telnet Port #3:   Off Line
                                                         FTP Push:         Off Line
                                                         FTP Server:       Off Line

Press <Enter> to return to menu ...

```

Figure 7.4: System Status Screen

### 7.3. System Status Screen

As shown in Figure 7.4, this screen summarizes communication parameters and general system parameters. The System Status Screen also lists installed memory modules, command port connection status, and Set-Up Switch Status. The System Status Screen lists the following:

- **Memory Configuration:** Installed memory modules, the amount of base memory, and the total memory capacity.
  - **Communication Settings:** Communication settings for PBX Ports A and B, the AUX Port, Console Port, and Modem Port. Note that communications settings for the PBX IP Port can be displayed via the PBX IP Port status screen as described in Section 7.18.
- Note:** The NLJ-VIP does not include PBX Port B or the Console Port.
- **Command Port Status:** The On-Line / Off-Line status of the Console Port and Modem Port.
  - **System Parameters:** User-defined access passwords (Supervisor Password not shown), Site I.D. message, and the status of the memory wrap-around feature.
  - **DIP Switch Settings:** Shows the current status of the eight DIP (Set-Up) Switches. Set-Up Switch functions are described in Section 4.2.
  - **Network Port Status:** The On-Line / Off-Line status of the three telnet ports, the FTP Push function, and the FTP Server Function.

```

PollCat NetLink-VIP      Version 1.06      11/08/2005 Tue 11:34 1% Full
SCHEDULED ACTION 1:

SCHEDULE                                ACTION PARAMETERS
Scheduled Action:      Off                Action:                None
Sunday:                Off                Phone #:              (undefined)
Monday:                Off                (Cont.):
Tuesday:               Off                Pager ID 1:           (undefined)
Wednesday:             Off                Pager ID 2:           (undefined)
Thursday:              Off                Pager ID 3:           (undefined)
Friday:                Off                SNMP Mgmt:            Manager #1
Saturday:              Off                Output Contacts
1/2/3/4:               -/-/-/
Message:                (undefined)
(Cont.):
(Cont.):
Auto Execute:           Off
Execute Cnds:           (undefined)
(Cont.):
(Cont.):
(Cont.):
Email To:                Email #1

Press <Enter> to return to menu ...

```

Figure 7.5: Scheduled Action Status Screen (Schedule 1 Shown)

## 7.4. Scheduled Action Status Screens

As shown in Figure 7.5, this screen lists parameters for the Scheduled Action feature, which allows the VIP to perform an action (such as a page, or SNMP Trap) according to a user-defined schedule. There are two separate Action Schedules. Section 14 describes the procedure for defining these schedules. This screen includes the following:

- **Schedule:** The currently defined action schedule. The scheduled action time is listed next to the day. Days that are not included are listed as "OFF".
- **Exclusions:** Specific dates (such as holidays) when the schedule will be automatically disabled.
- **Action Parameters:** Describes the action performed according to this schedule.
  - **Action:** The scheduled action; None, Callout, Alphanumeric Page, Numeric Page, SNMP Trap, Output Contact, Console action or Email/Text Message.
  - **Phone Number:** Number dialed for a scheduled callout or page.
  - **Pager ID Numbers:** The ID numbers that are used for a scheduled alphanumeric page.
  - **SNMP Manager:** The SNMP Manager(s) that will receive SNMP Traps generated by this schedule.

- **Output Contacts:** The scheduled Output Contact action. A "C" indicates the contact will be closed, an "O" indicates the contact will be opened, and a dash (-) indicates that the status of the contact will not be changed.
- **Message:** The message sent when a scheduled callout, alphanumeric page, SNMP Trap, or console port action is performed.
- **Auto Execute:** If enabled, the VIP will execute a user-defined command string when a scheduled callout or console action is performed.
- **Execute Commands:** The command string that will be performed when the Auto Execute feature is enabled, and a scheduled callout or console action is generated.
- **Email To:** The address(es) (defined via the Network Port configuration menu) that will receive email and text messages generated by this alarm.

```
PollCat NetLink-VIP   Version 1.06   11/08/2005 Tue 11:35  1% Full
DIALBACK SECURITY:

Dialback Security:  Off

Supervisor
Dialback Phone #:  (undefined)

User 1
Dialback Phone #:  (undefined)

User 2
Dialback Phone #:  (undefined)

Press <Enter> to return to menu ...
```

Figure 7.6: Dialback Security Status Screen

---

## 7.5. Dialback Security Status Screen

---

This screen (Figure 7.6) lists parameters for the Dialback Security feature. The Status Screen shows the On/Off status of the Dialback feature, and lists phone numbers each password. Dialback Security is defined and enabled using the Modem Port Configuration menu as described in Section 5.4.4.

```

PollCat NetLink-VIP   Version 1.06   11/08/2005 Tue 11:36  1% Full
DATA FILTERS & ALARMS:

FILTERS & ALARMS      PORT                                DEFAULT ALARM FILTER ACTION
Alarm Filter 1:      None                                Action:                      None
Alarm Filter 2:      None                                Phone #:                      (undefined)
Data Filter 1:       None                                (Cont.):
Data Filter 2:       None                                Pager ID 1:                  (undefined)
PBX Inact Alarm 1:   None                                Pager ID 2:                  (undefined)
PBX Inact Alarm 2:   None                                Pager ID 3:                  (undefined)
                                                             SNMP Mgmt:                   Manager #1

OTHER ALARMS
80% Full Alarm:      Off
Input Contact Alrm:  Off

OUTPUT CONTACTS (IDLE/NO ALARM)
Contacts 1/2/3/4:    C/C/C/C

CONTACTS CURRENT STATE (1/2/3/4)
Input Contact:       H/L/H/L
Output Contacts:     C/C/C/C

Output Contacts
1/2/3/4:             -/-/-/
Message:              (undefined)
(Cont.):
(Cont.):
Auto Execute:        Off
Execute Cnds:        (undefined)
(Cont.):
(Cont.):
(Cont.):
Send Alarm Records:  Off,2048,On,Off
Email To:             Email #1

Press <Enter> to return to menu ...

```

Figure 7.7: Data Filters & Alarms Status Screen

## 7.6. Data Filters & Alarms Status Screen

As shown in Figure 7.7, this screen displays parameters for the Data Filters, Alarm Filters, PBX Inactivity Alarms, 80% Full Alarm, and Input Contact Alarm. The screen also lists Default Alarm Filter Actions, and shows the status of the optional Input and Output Contacts.

- **Filters & Alarms:** Shows which port(s) are currently assigned to the Alarm Filters, Data Filters, and PBX Inactivity Alarms. If a Filter or Alarm is not currently assigned, the Port column will read "NONE".
- **Other Alarms:** The On/Off status of the 80% Full Alarm and Input Contact Alarm.
- **Output Contacts:** The Idle/Non-Alarm state for the output contacts (Optional; not available on NLJ-VIP Models.)
- **Contacts Current State:** The High/Low status of the optional Input Contacts, and Open/Closed status of the optional Output Contacts. (Optional; not available on NLJ-VIP Models.)
- **Default Alarm Filter Action:** The VIP will use these defaults for all new alarm clues.
  - **Action:** The default action performed when an alarm is generated; None, Callout, Alphanumeric Page, Numeric Page, SNMP Trap, Output Contact, Console action or Email/Text Message.
  - **Phone Number:** The default number that is dialed when the Alarm Filter generates a callout or page.

- **Pager ID Numbers:** The default ID numbers used when the Alarm Filter generates an alphanumeric page.
- **SNMP Management:** The default SNMP manager(s), which will receive SNMP Traps generated by Alarm Clues.
- **Output Contacts:** (Optional - not available on NLJ-VIP units) The default Output Contact action. A "C" indicates the contact will be closed when an alarm is generated, "O" indicates the contact will be opened, and a dash (-) indicates the status of the contact will not be changed.
- **Message:** The default message sent when the Alarm Filter generates a callout, alphanumeric page, SNMP Trap, or console port action.
- **Auto Execute:** The default On/Off state. When enabled, the VIP will execute a user-defined command string when a callout or console action is performed.
- **Execute Commands:** The default Auto-Execute command string. This command string will be performed when the Auto Execute feature is enabled, and a callout or console action is generated.
- **Send Alarm Records:** The On/Off status of the "Send Alarm Records" feature, which allows you to include the exact record that triggered the alarm when an Alphanumeric Page action is generated by the Alarm Filter.
- **Email To:** The default address(es) (defined via the Network Port configuration menu) that will receive email and text messages generated by this alarm.



```
PollCat NetLink-VIP    Version 1.06    11/08/2005 Tue 11:39  1% Full
ALARM CONDITION:

ALARM                PENDING
Alarm Filter 1 (PBX-A): No
Alarm Filter 2 (PBX-A): No
Alarm Filter 1 (PBX-B): No
Alarm Filter 2 (PBX-B): No
Alarm Filter 1 (AUX): No
Alarm Filter 2 (AUX): No
PBX Inact Alarm 1: No
PBX Inact Alarm 2: No
80% Full Alarm: No
Input Contact Alarm: No
Alarm Filter 1 (PBX IP): No
Alarm Filter 2 (PBX IP): No

Press <Enter> to return to menu ...
```

Figure 7.8: Alarm Condition Status Screen

## 7.7. Alarm Condition Status Screen

As shown in Figure 7.8, this screen lists alarm actions that have not been completed. For example, if the modem port is busy, and an alarm is generated which requires transmission via modem, the VIP will place the alarm in a queue to await processing. During this time, the Alarm Condition Status Screen will list the alarm action as "pending".

```

PollCat NetLink-VIP   Version 1.06   11/08/2005 Tue 11:39 1% Full
PBX INACTIVITY ALARM 1:

SCHEDULE                                     ALARM ACTION PARAMETERS
Weekday Alarm:           Off             Action:           None
Weekday Schedule 1:     00:00-00:00      Phone #:         (undefined)
Weekday Timer 1:        00:00            (Cont.):         (Cont.):
Weekday Schedule 2:     00:00-00:00      Pager ID 1:     (undefined)
Weekday Timer 2:        00:00            Pager ID 2:     (undefined)
Weekend Alarm:          Off             Pager ID 3:     (undefined)
Weekend Schedule 1:    00:00-00:00      SNMP Mgmt:      Manager #1
Weekend Timer 1:       00:00            Output Contacts
Weekend Schedule 2:    00:00-00:00      1/2/3/4:       -/-/-/-
Weekend Timer 2:       00:00            Message:        (undefined)
                                           (Cont.):
                                           (Cont.):
EXCLUSIONS (MM/DD)
--/--  --/--  --/--  --/--  Auto Execute:   Off
--/--  --/--  --/--  --/--  Execute Cnds:  (undefined)
--/--  --/--  --/--  --/--  (Cont.):
--/--  --/--  --/--  --/--  (Cont.):
--/--  --/--  --/--  --/--  (Cont.):
                                           Email To:      Email #1

Press <Enter> to return to menu ...
    
```

Figure 7.9: PBX Inactivity Alarm Status Screen (Alarm 1 Shown)

## 7.8. PBX Inactivity Alarm Status Screens

As shown in Figure 7.9, these screens list parameters for the PBX Inactivity Alarms. The VIP includes two separate PBX Inactivity Alarms. Each alarm has its own status screen, which lists the following:

- **Schedule:** On/Off Status, Schedules, and Timers for the Weekday and Weekend Alarms.
- **Exclusions:** Dates (such as holidays) when alarms will be disabled.
- **Alarm Action Parameters:** The action that will be performed when this alarm is triggered.
  - **Action:** Selected alarm action; None, Callout, Alphanumeric Page, Numeric Page, SNMP Trap, Output Contact, Console action or Email/Text Message.
  - **Phone Number:** The number dialed when the PBX Inactivity Alarm generates a callout or page action.
  - **Pager ID Numbers:** The pager ID numbers used when this alarm generates an alphanumeric page.
  - **SNMP Management:** The SNMP Manager(s) that will receive SNMP Traps generated by this alarm.

- **Output Contacts:** (Optional - Not available on NLJ-VIP units)  
A "C" indicates the contact will be closed, an "O" indicates the contact will be opened, and a dash (-) indicates that the status of the contact will not be changed (for more information, please refer to Section 11.)
- **Message:** Message sent when this PBX Inactivity Alarm generates a callout, alphanumeric page, SNMP Trap, or console action.
- **Auto Execute:** If enabled, the VIP will execute a user-defined command string when a callout or console action is generated.
- **Execute Commands:** The command string performed when Auto Execute is enabled, and a callout or console action is generated.
- **Email To:** The address(es) that will receive email and text messages generated by this alarm. This item is used to select one of two user-defined email messages that are defined via the Send Email configuration menu, as described in Section 5.4.5.1.

```
PollCat NetLink-VIP   Version 1.06   11/08/2005 Tue 11:40  1% Full
80% FULL ALARM:

80% Full Alarm:      Off
Action:              None
Phone #:             (undefined)
Pager ID 1:         (undefined)
Pager ID 2:         (undefined)
Pager ID 3:         (undefined)
SNMP Mgmt:          Manager #1
Output Contacts
1/2/3/4:            -/-/-/-
Message:            (undefined)
Auto Execute:       Off
Execute Cnds:       (undefined)
(Cont.):
Email To:           Email #1

Press <Enter> to return to menu ...
```

Figure 7.10: 80% Full Alarm Status Screen

---

## 7.9. 80% Full Alarm Status Screen

---

As shown in Figure 7.10, this screen lists parameters for the 80% Full Alarm. For more information, please refer to Section 11. This status screen lists the following:

- **80% Full Alarm:** The enabled/disabled status of the alarm.
- **Action:** The selected action that will be performed when an 80% Full Alarm is generated.
- **Phone Number:** The number dialed when the 80% Full Alarm generates a callout or page action.
- **Pager ID Numbers:** The ID numbers that are used when the 80% Full Alarm generates an alphanumeric page.
- **SNMP Manager:** The SNMP manager that will receive SNMP Traps generated by this alarm.
- **Output Contacts:** (Optional - Not available on NLJ-VIP units) The Output Contact action that can be performed when this alarm is triggered. A "C" means the contact will be closed, an "O" means the contact will be opened, a dash (-) means that the status of the contact will not be changed.
- **Message:** The message sent when this alarm generates a callout, alphanumeric page, SNMP Trap, or console action.
- **Auto Execute:** The On/Off state of the Auto Execute feature.
- **Execute Commands:** A command string that can be automatically executed when the 80% Full Alarm is triggered.

```
PollCat NetLink-VIP   Version 1.06   11/08/2005 Tue 11:41 1% Full
INPUT CONTACT ALARM:

Contact 1 Alarm:      Off
Trigger Level 1:     Low

Contact 2 Alarm:      Off
Trigger Level 2:     High

Contact 3 Alarm:      Off
Trigger Level 3:     Low

Contact 4 Alarm:      Off
Trigger Level 4:     High

Press <Enter> to return to menu ...
```

Figure 7.11: Input Contact Alarm Status Screen

## 7.10. Input Contact Alarm Status Screen

As shown in Figure 7.11, this screen shows the status of the Input Contact Alarms described in Section 12. The Status Screen lists the following:

**Note:** The Input Contact feature is optional on NetLink-VIP units, and is not available on NLJ-VIP units.

- **Contact Alarms (1 - 4):** Indicates if the Input Contact Alarm is enabled for the corresponding Input Terminal.
- **Trigger Levels (1 - 4):** Lists the contact state that will trigger an alarm at the corresponding Input Terminal.

```
PollCat NetLink-VIP   Version 1.06   11/08/2005 Tue 11:42  1% Full
REASON FOR ACTION

Alarm Action:
PBX Record Matched the Following Filter:

Alarm Filter:        1
Clue Name:           ALPHA
Match Count:         98
Message:             ALARM ALPHA

Press <ENTER> to return to previous menu ...
```

Figure 7.12: Reason for Action Screen

---

## 7.11. Reason for Action Screen

---

This screen (Figure 7.12) can be used to determine the exact reason for an alarm. Note that if an Alarm or Scheduled Action has not occurred, the VIP will display a message which reads, "Session Not Initiated by the VIP." The Reason for Action Screen includes the following:

- **Alarm Action:** A brief description of the last alarm action or scheduled action performed by the VIP.
- **Alarm Filter:** The alarm filter that generated the action.
- **Clue Name:** The clue that generated the alarm action.
- **Match Count:** The counter value for the clue.
- **Message:** The user-defined alarm message for the clue that generated the alarm action.

```

PollCat NetLink-VIP   Version 1.06   11/08/2005 Tue 11:43 1% Full
PBX PORT A:

COMMUNICATION SETTINGS
Com Settings:        9600,E,7,1,None

INPUT PARAMETERS
Time/Date Stamp:    Off
Serial # Stamp:     Off
Strip Non-Print:    On
End Character:      ^J
Alarm Filter:       None
Store Alarm Data:   Alarm
Data Filter:        None
PBX Inact Alarm:    None

Press <Enter> to return to menu ...

```

Figure 7.13: PBX Port Status Screen (PBX Port A Shown)

## 7.12. PBX Port Status Screens

These screens list parameters for the PBX Ports. There are separate status screens for PBX Ports A and B. As described in Section 5.4.1, port parameters are selected via the Port Configuration menus.

**Note:** NLJ-VIP units do not include PBX Port B.

- **Communication Settings:** Lists Baud Rate, Parity, Data Bits, Stop Bits, and Handshake Mode for this port.
- **Input Parameters:** Selected input parameters for this port:
  - **Time Date Stamp:** When enabled, the VIP will insert a Long Format or Short Format Time/Date Stamp at the beginning of each record received via this port.
  - **Serial Number Stamp:** When enabled, a serial number will be inserted at the beginning of each record received by this port.
  - **Strip Non-Print:** When enabled, the VIP will remove non-printable characters from all records received via this port.
  - **End Character:** The selected End-of-Record character for this port.
  - **Alarm Filter:** The Alarm Filter selected for this port.
  - **Store Alarm Data:** Indicates where the VIP will store alarm records received via this port.
  - **Data Filter:** The Data Filter selected for this port.
  - **PBX Inact Alarm:** The On/Off status of the PBX Inactivity Alarm for this port.

```
PollCat NetLink-VIP   Version 1.06   11/08/2005 Tue 11:43  1% Full
AUXILIARY PORT:

COMMUNICATION SETTINGS
Com Settings:        9600,E,7,1,None

INPUT PARAMETERS
Time/Date Stamp:    Off
Serial # Stamp:     Off
Strip Non-Print:    On
End Character:      ^J
Alarm Filter:       None
Store Alarm Data:   Alarm
Data Filter:        None
PBX Inact Alarm:    None
Port Mode:          Store Data

Press <Enter> to return to menu ...
```

Figure 7.14: Auxiliary Port Screen

### 7.13. Auxiliary Port Status Screen

This screen lists parameters for the Auxiliary Port. Parameters are selected via the Port Configuration menu (Section 5.4.2).

**Note:** NLJ-VIP units do not include the AUX Port.

- **Communication Settings:** Lists Baud Rate, Parity, Data Bits, Stop Bits, and Handshake Mode for the Auxiliary Port.
- **Input Parameters:** Lists input parameters for this port:
  - **Time Date Stamp:** When enabled, the time and date will be inserted into records received via this port.
  - **Serial Number Stamp:** When enabled, a serial number will be inserted into records received via this port.
  - **Strip Non-Print:** When enabled, the VIP will remove non-printable characters from all records received via this port.
  - **End Character:** The selected End-of-Record character for this port.
  - **Alarm Filter:** The Alarm Filter selected for this port.
  - **Store Alarm Data:** Indicates where the VIP will store alarm records received via this port.
  - **Data Filter:** The Data Filter selected for this port.
  - **PBX Inact Alarm:** The PBX Inactivity Alarm selected for this port.
  - **Port Mode:** The selected operation mode for the AUX Port; either Store Data or Discard Data.



```

PollCat NetLink-VIP   Version 1.06   11/08/2005 Tue 11:44  1% Full
CONSOLE PORT:

COMMUNICATION SETTINGS                                OUTPUT PARAMETERS
Com Settings:      9600,N,8,1,RTS                    Output Mode:      ASCII Record
                                                           Data on ^B01:    On
                                                           Hold "End Data": On
                                                           Line # Tag:      Off
                                                           Send Compressed: Off
                                                           Auto Delete:     Off

                                                           OUTPUT PARAMETERS (BINARY BLOCK)
                                                           Transmit Attempts: 3 Att/5 Secs
                                                           DLE Stuffing:    Off

GENERAL PARAMETERS
Command Echo:      On
Response Type:     Inhibit Menu
"Sure" Prompt:     On
CMD Port Timeout:  15 Mins
Audit Trail:       Off

ACTION PARAMETERS
Action Delay:      10 Secs

Press <Enter> to return to menu ...

```

Figure 7.15: Console Port Status Screen

## 7.14. Console Port Status Screen

As shown in Figure 7.15, this screen lists parameters for the Console Port. Console Port Parameters are selected via the Console Port Configuration Menu (Section 5.4.3.)

- **Communication Settings:** Lists Baud Rate, Parity, Data Bits, Stop Bits, and Handshake Mode for the Console Port.
- **General Parameters:**
  - **Command Echo:** When enabled, commands sent to this port will be echoed back to the polling device.
  - **Response Type:** Upon start up, this port can either display the Main Menu, or withhold the Main Menu until [Enter] is pressed.
  - **"Sure" Prompt:** When enabled, a prompt will be displayed before destructive commands are completed.
  - **CMD Port Timeout:** The Console Port timeout value.
  - **Audit Trail:** When enabled, the VIP will log command activity.
- **Action Parameters:** The amount of time that will elapse between alarm actions sent from this port.

- **Output Parameters:** Lists the following parameters for this port:
  - **Output Mode:** The format used when data is released via this port; ASCII Record, Binary Block, Xmodem, or Zmodem.
  - **Data on ^B01:** When disabled, ^B02 is sent to begin data release.
  - **Hold End Data:** When enabled, a ^B02 is required in order to release the "End Data" message.
  - **Line # Tag:** When enabled, a line number will be inserted at the beginning of each record released by this port.
  - **Send Compressed:** When enabled, this port will release data in space compressed format.
  - **Auto Delete:** When enabled, stored data will be erased after the polling device acknowledges reception.
- **Output Parameters (Binary Block):** Lists parameters that are used when this port releases data in Binary Block format:
  - **Transmit Attempts:** The number of transmit attempts, and the delay between attempts.
  - **DLE Stuffing:** When enabled, literal characters can be inserted into binary data released via this port.

```

PollCat NetLink-VIP   Version 1.06   11/08/2005 Tue 11:45 1% Full
MODEM PORT:          Modem Installed

COMMUNICATION SETTINGS                                OUTPUT PARAMETERS
Com Settings:        57600,N,8,1,RTS                Output Mode:        ASCII Record
Reset String:        ATZ                             Data on ^B01:       On
Init String:         ATEOM0Q1&C1&D2S0              Hold "End Data":    On
(Cont.):              =1                             Line # Tag:         Off
Hang-Up String:      (undefined)                    Send Compressed:    Off
(Cont.):              (Cont.):                       Auto Delete:        Off

                                                                OUTPUT PARAMETERS (BINARY BLOCK)
                                                                Transmit Attempts: 3 Att/5 Secs
                                                                DLE Stuffing:      Off

GENERAL PARAMETERS
Command Echo:        On
Response Type:       Inhibit Menu
"Sure" Prompt:       On
CMD Port Timeout:    15 Mins
Audit Trail:         Off

ACTION PARAMETERS
Action Delay:        300 Secs

                                                                CALLOUT PARAMETERS
                                                                Dial Attempts:     3
                                                                Sequence Attempts: 3 Att/10 Mins
                                                                Immediate Callout: Off
                                                                Immediate Phone #: (undefined)
                                                                (Cont.):
                                                                Dialback Security: Off

Press <Enter> to return to menu ...

```

Figure 7.16: Modem Port Status Screen

## 7.15. Modem Port Status Screen

As shown in Figure 7.16, this screen lists parameters for the Modem Port. Modem Port Parameters are selected via the Modem Port Configuration Menu (Section 5.4.4.)

- **Communication Settings:**
  - **Com Settings:** Baud Rate, Parity, Data Bits, Stop Bits, and Handshake Mode for the Modem Port.
  - **Reset String:** The Modem Reset String.
  - **Init. String:** The Modem Initialization String.
  - **Hang-Up String:** The Modem Hang-Up String.
- **General Parameters:**
  - **Command Echo:** When enabled, commands will be echoed back to the polling device.
  - **Response Type:** Upon login, this port will either display the Main Menu immediately, or wait until [Enter] is pressed.
  - **"Sure" Prompt:** When enabled, a prompt is displayed before certain irreversible commands are completed.
  - **CMD Port Timeout:** The command mode timeout value.
  - **Audit Trail:** When enabled, the VIP will log command activity.

- **Action Parameters:** The amount of time that will elapse between alarm actions sent from this port.
- **Output Parameters:**
  - **Output Mode:** The format used when data is released via this port; ASCII Record, Binary Block, Xmodem, or ZModem.
  - **Data on ^B01:** When disabled, ^B02 is sent to begin data release.
  - **Hold End Data:** When enabled, ^B02 is sent to release the "End Data" message.
  - **Line # Tag:** When enabled, a line number will be inserted at the beginning of each record released by this port.
  - **Send Compressed:** When enabled, this port will release data in space compressed format.
  - **Auto Delete:** When enabled, stored data will be erased after the polling device acknowledges reception.
- **Output Parameters (Binary Block):** Lists parameters used when this port releases data in Binary Block format:
  - **Transmit Attempts:** The number of transmit attempts, and the length of the delay between attempts.
  - **DLE Stuffing:** When enabled, literal characters can be inserted into binary data released via this port.
- **Callout Parameters:**
  - **Dial Attempts:** The number of times the VIP will attempt to place a call.
  - **Sequence Attempts:** The number of times the VIP will restart the dial-out process, and delay between each sequence of attempts.
  - **Immediate Callout:** When enabled, the VIP will dial the Callout Number immediately after the user disconnects.
  - **Immediate Phone #:** The Immediate Callout phone number.
  - **Dialback Security:** The status of the Dialback Security feature.

```

PollCat NetLink-VIP   Version 1.06   11/08/2005 Tue 11:46 1% Full
NETWORK PORT:       NIC Installed

COMMUNICATION SETTINGS                                OUTPUT PARAMETERS
MAC Address:       00-40-f4-6e-eb-a6   Output Mode:      ASCII Record
IP Address:       192.168.168.168     Data on ^B01:    On
Subnet Mask:     255.255.255.0       Hold "End Data": On
Gateway:         (undefined)         Line # Tag:      Off
SNMP Mgmt 1 Addr: (undefined)         Send Compressed: Off
SNMP Mgmt 2 Addr: (undefined)         Auto Delete:     Off
SNMP Community:  public
Send MSS:        1460

GENERAL PARAMETERS
Command Echo:    On
Response Type:   Inhibit Menu
"Sure" Prompt:   On
CMD Port Timeout: 15 Mins
Audit Trail:     Off

ACTION PARAMETERS
Action Delay:    10 Secs

Press <Enter> to return to menu ...

```

Figure 7.17: Network Port Status Screen

## 7.16. Network Port Status Screen

As shown in Figure 7.17, this screen lists parameters for the Modem Port. Modem Port Parameters are selected via the Modem Port Configuration Menu (Section 5.4.4.)

- **Communication Settings:**
  - **MAC Address:** The Media Access Control Address.
  - **IP Address:** The VIP's IP Address.
  - **Subnet Mask:** The VIP's Subnet Mask.
  - **Gateway:** The VIP's Gateway Address.
  - **SNMP Mgmt 1 Addr:** IP address for SNMP Manager 1.
  - **SNMP Mgmt 2 Addr:** IP address for SNMP Manager 2.
  - **SNMP Community:** The user-defined SNMP Community.
- **General Parameters:**
  - **Command Echo:** When enabled, commands sent to this port will be echoed back to the polling device.
  - **Response Type:** Upon login, this port can either display the Main Menu immediately, or wait until [Enter] is pressed.
  - **"Sure" Prompt:** When enabled, a prompt will be displayed before certain irreversible commands are completed.
  - **CMD Port Timeout:** The Network Port timeout value.

- **Audit Trail:** When enabled, the VIP will log command activity.
- **Action Parameters:** The Action Delay lists the amount of time that will elapse between actions sent out via this port.
- **Output Parameters:** Lists Output Parameters for this port:
  - **Output Mode:** The format used when data is released via this port; ASCII Record, Binary Block, Xmodem, or Zmodem.
  - **Data on ^B01:** When disabled, ^B02 is sent to begin data release.
  - **Hold End Data:** When enabled, ^B02 is sent to release the "End Data" message.
  - **Line # Tag:** When enabled, a line number will be inserted at the beginning of each record released by this port.
  - **Send Compressed:** When enabled, this port will release data in space compressed format.
  - **Auto Delete:** When enabled, stored data will be erased after the polling device acknowledges reception.
- **Output Parameters (Binary Block):** Lists parameters that are used when this port releases data in Binary Block format:
  - **Transmit Attempts:** The number of transmit attempts, and the length of the delay between attempts.
  - **DLE Stuffing:** When enabled, literal characters can be inserted into binary data released by this port.

```

PollCat NetLink-VIP      Version 1.06      11/08/2005 Tue 11:47 1% Full
NETWORK STATUS:

TCB SRC PORT STATE          SOURCE IP ADDR | PORT          TCB STATE
  0   None Listen              None | Telnet #1    2 Connected
  1   None Listen              None | Telnet #2    3 Not Conn
  2  9067 Established 207.212.30.3 | Telnet #3    None Not Conn
  3   None Listen              None | PFTP Cmd     None Not Conn
  4   None Free                None | PFTP Data    None Not Conn
  5   None Free                None | SFTP Cmd     0 Conn Rqst
  6   None Free                None | SFTP Data    None Disconn
  7   None Free                None | SMTP         None Not Conn
  8   None Free                None | PBX IP       1 Not Conn

Press <Enter> to return to menu ...

```

Figure 7.18: Network Status Screen

## 7.17. Network Status Screen

This screen lists advanced diagnostic information, which can be used to check the status of each available telnet and FTP connection.

### Client Connection Information:

- **TCB:** Transmission Control Block; lists each client connection.
- **SRC PORT:** Lists each client's TCP port number.
- **STATE:** Lists each client's transmission control protocol status.
- **SOURCE IP ADDR:** Lists each client's IP address.

### VIP Connection Information:

- **PORT:** Lists each VIP telnet and FTP port.
- **TCB:** Transmission Control Block; shows which port is connected to each TCB.
- **STATE:** Lists the transmission control protocol status for each VIP Telnet and FTP port.

```
PollCat NetLink-VIP   Version 1.06   11/08/2005 Tue 11:47  1% Full
PBX IP PORT:

COMMUNICATION SETTINGS
Service:              On
Port Number:          9000
Window Size:          6
Keep Alive Send:      60 Secs
Keep Alive Resp:      60 Secs
SDM Resp:             30 Secs

INPUT PARAMETERS
Time/Date Stamp:      Off
Serial # Stamp:        Off
Strip Non-Print:      On
End Character:         ^J
Alarm Filter:          None
Store Alarm Data:      Alarm
Data Filter:           None
PBX Inact Alarm:       None

Press <Enter> to return to menu ...
```

Figure 7.19: PBX IP Port Status Screen

## 7.18. PBX IP Port Status

This screen lists parameters for the PBX IP Port. PBX IP Port Parameters are defined via the Port Configuration Menus, as described in Section 5.4.6. The PBX Port Status Screen includes the following:

### Communication Settings:

- **Service:** Shows the On/Off status of the PBX IP Port feature.
- **Port Number:** The RSP Port Number.
- **Window Size:** The RSP Window Size.
- **Keep Alive Send:** The "keep alive send" timeout in seconds.
- **Keep Alive Response:** The "keep alive response" timeout in seconds.
- **SDM Response:** The session disconnect message response timeout in seconds.

### Input Parameters:

- **Time/Date Stamp:** When enabled, the VIP will insert a time/date stamp at the beginning of each data record received by this port.
- **Serial Number Stamp:** When enabled, the VIP will insert a six digit number at the beginning of each record received by this port.
- **Strip Non-Printables:** When enabled, the VIP will exclude non-printable characters such as Nuls and Dels.
- **End Character:** The End-of-Record character that the VIP will expect to see at the end of each record received at this port.



- **Alarm Filter:** The Alarm Filter that is currently selected for this port.
- **Store Alarm Data:** Indicates where the VIP will store alarm data received via this port. Alarm Records can be stored in the Alarm File, the Standard (non-alarm) File, or both.
- **Data Filter:** The Data Filter that is currently selected for this port.
- **PBX Inactivity Alarm:** When properly configured and enabled, the PBX Inactivity Alarm will notify you when there is an interruption in the flow of data to this port.

## 7.19. Alarm Filter Clue Status Screens

These screens list the status of clues for each of the two Alarm Filters at each available VIP input port. Note that NLJ-VIP units do not include PBX Port B or the AUX Port. The Alarm Filter Clue Status Screens (Figure 7.20) list the following:

- **Clue Name:** The name of each defined clue for this Alarm Filter.
- **Threshold Count:** The number of times that this clue must be matched in order to generate an alarm.
- **Match Count:** The number of times this event has occurred since the last counter reset.
- **Alarm Status:** The status of the last alarm generated by each clue as follows:
  - **Pending:** The alarm is still waiting to be sent
  - **Success:** The alarm has already been sent.
  - **Failure:** The unit was not able to send the Alarm
  - **Dashes (---):** No Alarm has been generated.

```

PollCat NetLink-VIP   Version 1.06   11/23/2005 Wed 14:47  0% Full
ALARM FILTER 1 CLUE STATUS (PBX-A) :

```

Clue Name	Threshold Count	Match Count	Alarm Status
test_fl_1	35	1	---
test_fl_2	20	0	---
test_fl_3	15	3	---

```

Press <Enter> to return to menu ...

```

Figure 7.20: Alarm Filter Clue Status Screen (PBX Port A, Alarm Filter 1 Shown)



## 8. The Data Filters

---

The Data Filters allow you to make the most efficient use of the VIP's memory by excluding records (such as inbound calls) that are not needed for your call accounting application. When the Data Filters are correctly configured, the VIP will monitor each record received from the PBX. Records that do not meet the user-defined criteria will not be stored.

The configuration procedure consists of three tasks:

- Define the Data Filter Format
- Define the Data Filter Parameters
- Enable the Data Filter

The VIP features two separate Data Filters. Each filter has its own format, variables, and storage criteria. When two dissimilar PBX units are connected to the VIP, this provides a separate Data Filter for each PBX.

### Notes:

- When the VIP is connected to two *different* types of PBX units, it is recommended to define a separate Data Filter for each PBX.
- A Data Filter that is defined for one PBX may not function with another type of PBX. For example, a Data Filter defined for the PBX connected to Port A, may not function correctly when assigned to a different type of PBX connected to Port B.

Each Data Filter Consists of a "Format" and one or more "Clues". The Format assigns variables to individual call record locations; Clues define the parameters that will be used as the criteria for rejection or storage of each call record.

### 8.1. The Data Filter Configuration Menus

---

To access the Data Filter Configuration Menus, from the Main Menu, type **26** and press **[Enter]**. A selector menu will appear. Type **1** for Data Filter 1, or **2** for Data Filter 2, and then press **[Enter]**. The Data Filter Configuration Menus (Figure 8.1) offer the following options:

1. **Data Filter Action:** Determines whether the Filter will store or reject records that match Clues. If the Data Filter Action is "Reject", the VIP will reject all records that match Data Filter Clues. If the action is "Store", the VIP will store all records that match Clues.

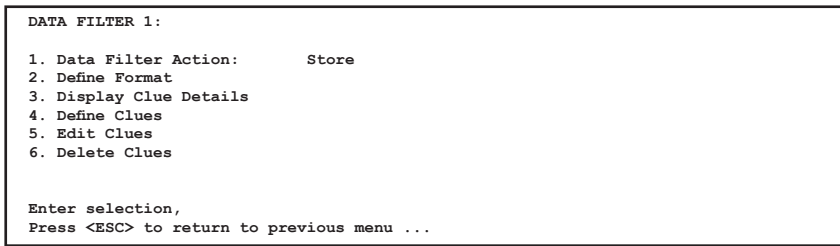

Figure 8.1: Data Filter Configuration Menu (Data Filter 1 Shown)

2. **Define Format:** Defines the Data Filter Format as described in Section 8.2.
3. **Display Clue Details:** After Clues are defined, this item is used to review parameters assigned to each Clue.
4. **Define Clues:** Several Data Filter parameters can be combined into a single Clue, or individual parameters can be defined under separate Clues to create a logical "Or" condition. Section 8.3 describes Clue Definition.
5. **Edit Clues:** Allows the user to edit or alter existing Clues.
6. **Delete Clues:** After Clues are defined, this item can be used to delete individual clues as described in Section 8.3.

## 8.2. Defining the Data Filter Format

---

The Data Filter Format describes the location of various "fields" within each call record. Proper definition of the Data Filter Format tells the VIP where to look, in order to determine if a given record should be omitted or stored.

Different types of PBX units will produce records with a slightly different structure. In order to define the Data Filter Format, you must first examine several records from the PBX. This will allow you to determine the exact record structure.

After the format has been determined, the next step is to assign variables to the fields that you intend to monitor. The Data Filter Format allows definition of up to 26 variables (the uppercase letters A through Z), which are used to indicate specific call record fields or locations. These variables are used later when defining Data Filter Clues.



```
DEFINE FORMAT:

In order to assist the user during format definition, several data records
and the previous format are displayed in the following order:

Data Records      (If available)
Previous Format    (If available)

                Enter new format at cursor.
                <Space><Enter> to clear.
                Use upper case letters for fields,
                '-' between fields

|08:16|075|B.JOHNSON      |IN |                |00:55|00.00|
|08:18|067|R.JONES       |OUT|19495839514    |05:36|00.75|
|08:20|092|J.SMITH       |OUT|18008547226    |11:15|00.00|
(undefined)
-----
-----AAAAAAAA-----
```

Figure 8.3: Data Filter Format Definition Example

6. Define the Data Filter Format: The prompt at the bottom of the menu is used to define the Data Filter.
  - a) Press the dash key to indicate a field position that you do not need to monitor. The last line in Figure 8.3 shows a Data Filter Format where dashes have been entered in the first four fields of the call record.
  - b) When you reach a field you want to monitor, type a series of variables (any uppercase letter from A to Z) to assign that variable to the position. For example, to assign the variable "A" to represent the first seven digits of the number dialed, enter seven A's (**AAAAAAA**). The same variable is repeated for each position in the field. It is not necessary to define variables in alphabetic order.
  - c) When you reach the end of the call record, or the last position you need to monitor, press **[Enter]**. The Data Filter Format will be saved, and the VIP will return to the Data Filter Configuration menu.

### 8.3. Defining Data Filter Clues

Data Filter match parameters describe the specific criteria that the VIP will use to determine if call records should be stored or rejected. Storage/rejection criteria are referred to as "Clues". Parameters can be combined under a single Clue, or divided between a series of Clues to create a logical "OR" condition.

Clues are defined using item 4 on the Data Filter Configuration Menu (Figure 8.1). Each Clue will usually include the following:

- **Variable(s):** One or more variables from the Data Filter Format, which designate the field(s) to be monitored. For example, the variable may represent the call record field for the number dialed.
- **Operator(s):** One or more of the logical or comparative operators described in Section 8.4.
- **Parameter(s):** A description of call characteristics used as the criteria for storage or rejection. For example, specific numbers or area codes for which records will not be stored.

To define Data Filter clues, proceed as follows:

1. Access the Data Filter Configuration Menu.
2. **Data Filter Action:** Type 1 and press **[Enter]** to specify whether the filter will store or reject records that match Clue Parameters.
3. **Define Clues:** Type 4 and press **[Enter]** to define parameters that will be used as the criteria for storage or rejection. The Define/Edit Clue menu will appear.
  - a) **Clue Name:** From the Clue Definition menu, type 1 and press **[Enter]** to assign a Clue Name. This name can be used to reference a specific clue when altering or deleting clues.
  - b) **Match Parameters:** Type 2 and press **[Enter]** to define the criteria for storage or rejection. Match Parameters consist of one or more variable(s) from the Data Filter Format, one of the logical operators discussed in Section 8.4, and the value that will be matched (e.g. the number dialed).

**Example:** If the Data Filter Format assigns "A" to represent the call record field for the number dialed, then **A=5551212** tells the VIP to check this field for the number 555-1212.
  - c) Match Parameters may reference several variables, may include logical operators, and may also include logical "AND/OR" conditions. Please refer to the examples in Section 8.7.
4. **Display Clue Details:** Item 3 can be used to review clue parameters. Type 3 and press **[Enter]**, the VIP will list all defined clue names. Key in the name of the desired clue and press **[Enter]**; parameters for the specified clue will be displayed.

5. **Edit Clues:** To alter an existing Clue, type **5** and press **[Enter]**. The VIP will list all clue names defined for the current filter. Key in the desired clue name and then press **[Enter]**. The Define/Edit Clue menu will be displayed, allowing the user to edit clue parameters.
6. **Delete Clues:** To delete an existing Clue, type **6** and press **[Enter]**. The VIP will list all clue names defined for the current filter. Key in the name of the clue you wish to delete and press **[Enter]**; the clue will be deleted.

**Note:** Deleted clues cannot be automatically restored.

## 8.4. Logical and Relational Operators

---

Variables and operators are combined to form match parameters. Variables are the uppercase letters A through Z, as defined in the Data Filter Format. Relational and logical operators are described below.

Operator	Function
>	Greater Than
<	Less Than
>=	Greater Than or Equal to
<=	Less Than or Equal to
~	Not. Can also precede other comparison operators (e.g. ~<, Not Less Than)
=	Equal To
\$	Contains String. Searches for specified string anywhere in a field
-	(Dash) Wild Card Character
( )	(Parentheses) Used to Combine and Prioritize Operations
+ or	Logical OR Conditions
* or &	Logical AND Conditions



## 8.4.1. Logical AND/OR Conditions

Logical AND/OR conditions can be created by including the AND operators, or the OR operators in the match parameter definition. A logical OR condition can also be created by defining a series of match parameters using a separate Clue for each parameter.

### 8.4.1.1. Logical AND Conditions

The AND operators (\* and &) link parameters in a manner where two or more conditions must *all* be true in order for the record to match the filter.

**Example:** Assume "A" represents the field for the number dialed, and "B" represents the extension number. To define a Data Filter Clue that accepts records for calls placed to 555-1111 from extension 013, match parameters would be defined as follows:

**A=5551111\*B=013 or A=5551111&B=013**

This Data Filter Clue would *only* accept calls placed to 555-1111 AND placed from extension 013. Calls to 555-1111 from extension 086 would *not* be accepted, and calls to 555-2222 from extension 013 would also not be accepted.

### 8.4.1.2. Logical OR Conditions

The OR operators (+ and |) link parameters in a manner where *any* of two or more conditions must be true in order for the record to match the filter.

**Example:** Assume the variable "A" represents the field for the number dialed, and "B" represents the extension number. To define a Data Filter Clue that accepts records for calls placed to 555-1111 OR placed from extension 013, match parameters would be defined as follows:

**A=5551111+B=013 or A=5551111|B=013**

This Data Filter Clue would accept all calls that are placed to 555-1111 OR placed from extension 013. Calls to 555-1111 from extension 086 *would* be accepted, and calls to 555-2222 from extension 013 *would also* be accepted.

Another method for creating an OR condition is to define match parameters using separate clues. When a series of clues are defined, the record will be flagged if any of the defined clues are matched. In the preceding example, the same results could also be achieved by defining the following clues:

Clue Name	Match Parameter
NUMBER	A=5551111
EXTENSION	B=013

08:16 075 B. JOHNSON	OUT 17145551212	00:55 00.00
08:18 067 R. JONES	OUT 19495557714	05:36 00.75
08:20 092 J. SMITH	OUT 18007140000	11:15 00.00
-----AAAAAAAA-----		

Figure 8.4: The "Contains String" Operator Example

### 8.4.2. The "Contains String" Operator

The "Contains String" Operator (\$) is used to search an entire variable field for a given value or text string, without regard for the item's position within the field.

For example, assume the variable "A" represents the first eleven characters in the "Number Dialed" field as shown in Figure 8.4. If Match Parameters are defined as "A\$714", then the VIP will search all eleven digits of the field. This Data Filter would match any record that contains "714" *anywhere* in the phone number, including records where "714" is the area code, and records where 714 is part of the number dialed.

## 8.5. Real-Time Variables

Data Filter Clues can also include Real-Time variables that monitor the VIP's internal clock and calendar

Real-Time variables do not use the Data Filter Format, or monitor the contents of the call record. When Real-Time variables are used, the VIP will check its internal clock and calendar as each record is received. If the time and/or date matches the Clue definition, the call is flagged and stored or rejected as specified by the Data Filter Action prompt. The VIP's internal clock, rather than the contents of the call record, determines whether the record is stored or rejected.

The following Real-Time variables can be used to monitor the internal clock and calendar.

**Note:** Real-Time variables are always entered as lowercase characters.

- t Time:** Tells the VIP to determine the time each record is received. Time is entered in "HH:MM" format, where HH is the hour (00 - 23), and MM is the minute (00 - 59).
- w Day of the Week:** Tells the VIP to determine the day of the week when the record is received. The day of the week is entered as a single digit, where 1 = Sunday, 2 = Monday, 3 = Tuesday, 4 = Wednesday, 5 = Thursday, 6 = Friday, and 7 = Saturday.
- d Date:** Tells the VIP to determine the date the record is received. The date is entered in "MM/DD" format, where MM is the month (01 - 12) and DD is the date (01 - 31).

**Example 1:** To create a Data Filter Clue that will reject call records received on Sunday, match parameters would be defined as  $w=1$ . Where  $w$  is the Real-Time variable for the day of the week, and  $1$  indicates Sunday.

**Example 2:** To create a Data Filter Clue that will reject call records received after 6:00 pm (18:00) or before 7:00 am (07:00), match parameters would be defined as follows:

$$t > 18:00 + t < 07:00$$

Where  $t$  is the Real-Time variable for the time of the day, and  $+$  is the logical OR operator.

### Notes:

- Real-Time variables are not defined in the Data Filter Format.
- Match parameters can include both Real-Time variables and regular variables, as well as logical and relational operators.
- Real-Time variables function independently from the Time/Date Stamp. The Time/Date Stamp does not have to be enabled in order for the Real-Time variables to function.
- Values from the internal clock/calendar are not included in the call record, unless the Time/Date Stamp is enabled.

## 8.6. Assigning the Data Filter to a Port

After the Data Filter is defined, the next step is to assign the filter to one or more of the input ports. The port configuration menus are used to assign one of the two available Data Filters to each port as described in Section 5.4. Note that Data Filters will not function unless they are assigned to a port.

## 8.7. Data Filter Definition Examples

The following examples are based on fictional PBX call record formats. When designing your Data Filter, be aware that the record format will differ from those shown in the examples. When defining the Data Filter Format and Match Parameters the following factors should be considered:

- **Exact Match:** Alphanumeric values in parameter definitions must exactly match those found in the call record. If the record lists the time as "09:00", then the parameter definition must also list time as "09:00" (not "0900" or "9:00").
- **Number of Characters :** For any given variable, the number of characters specified in the Data Filter Format must exactly match the number of characters indicated in the Match Parameters definition. For example, if the filter format defines "B" as the first seven characters of the number dialed, the parameter definition must account for all seven characters.

- **Cumulative Effect:** Each time a Data Filter Clue is defined, the VIP will add the new parameter to the existing definition. When multiple clues are defined, an OR condition is created. If the call record matches a defined clue, the record is then stored or rejected as indicated by the Data Filter Action.
- **Searching for Operator Characters:** When searching for a string that contains a space or any character that is also an operator, a backslash (\) must precede the space or operator. For example, to search for "\*\*\*Error\*\*\*", match parameters would be defined as "\\*\\*\\*Error\\*\\*\\*". Likewise, to search for "hello there", match parameters would be defined as "hello\ there".
- **Variable Case:** When defining and using variables, take care to use the correct case. Real Time variables are always entered as lowercase characters; regular variables are always entered as uppercase characters.

### Example 1: Multiple AND Conditions

This example shows a Data Filter that uses multiple AND conditions to simultaneously monitor two different call characteristics. Assume the Data Filter Format is defined as shown in Figure 8.5.

08:16 075 B.JOHNSON	OUT 17145551212	00:55 00.00
08:18 067 R.JONES	OUT 19495557714	05:36 00.75
08:20 092 J.SMITH	OUT 18007140000	11:15 00.00
-----AAAAAAAA-----		

Figure 8.5: Data Filter Example 1

Where:

- A The field that lists the time the call was received or placed.
- B The field that lists call duration.

Define a Data Filter that will only store records for calls received or placed between 8:00 am (08:00) and 5:00 pm (17:00), and lasting longer than five (5) minutes. The Data Filter Action would be set at "Store", and Match Parameters would be defined as:

**A>08:00&A<17:00&B>05:00**

Where:

- A>08:00** Stores records for calls received or placed after 08:00.
- &** Logical AND
- A<17:00** Stores records for calls received or placed before 17:00.
- &** Logical AND
- B>05:00** Stores records for calls that last longer than five minutes.

## Example 2: Multiple OR Conditions

This example shows a Data Filter that uses multiple OR conditions to store call records which conform to one of several listed characteristics. Assume the Data Filter Format is defined as shown in Figure 8.6.

08:16 075 B. JOHNSON	IN	00:55 00.00
08:18 067 R. JONES	OUT 19495839514	05:36 00.75
08:20 092 J. SMITH	OUT 18008547226	11:15 00.00
-----AAA-----		

Figure 8.6: Data Filter Example 2

Where **A** indicates the field that lists the extension number.

Define a Data Filter that will only store records for calls received or placed by extensions 013, 086, 099, *or* 101. The Data Filter Action would be set at "Store", and Match Parameters would be defined as follows:

**A=013+A=086+A=099+A=101**

Where:

- A=013** Stores records for calls received or placed at extension 013.
- +** Logical OR
- A=086** Stores records for calls received or placed at extension 086.
- +** Logical OR
- A=099** Stores records for calls received or placed at extension 099.
- +** Logical OR
- A=101** Stores records for calls received or placed at extension 101.

**Note:** Match Parameters for this Data Filter could also be defined by entering each "A=xxx" expression under a separate clue name.

## Example 3: Combining Logical AND Conditions and Logical OR Conditions

This example combines a logical AND condition and a logical OR Condition. Assume the Data Filter Format is defined as shown in Figure 8.7.

08:16 075 B. JOHNSON	IN	00:55 00.00
08:18 067 R. JONES	OUT 19495839514	05:36 00.75
08:20 092 J. SMITH	OUT 18008547226	11:15 00.00
-----AAAAA-BBB-----		

Figure 8.7: Data Filter Example 3

Where:

- A** Is the field that lists the time the call was received or placed.
- B** Is the field that lists the extension number.

Given the Data Filter Format shown in Figure 8.7, define a Data Filter that will store records for calls received or placed between 7:00 am (07:00) and 6:30 pm (18:30). In addition, the Data Filter must also store records for calls received or placed by extension 013. The Data Filter Alarm Action would be set at "Store", and Match Parameters would be defined as follows:

**(A>07:00&A<18:30)+B=013**

Where:

- A>07:00** Stores records for calls received or placed after 07:00.
- &** Logical AND
- A<18:30** Stores records for calls received or placed before 18:30.
- +** Logical OR
- B=013** Stores records for calls received or placed at extension 013.

**Note:** Parentheses are used to group the two parts of the logical AND condition.

#### Example 4: The "Wild Card" Operator

This example shows a Data Filter that uses the "Wild Card" operator. Assume the Data Filter Format is defined as shown in Figure 8.8.

08:16 075 B. JOHNSON	IN	00:55 00.00
08:18 067 R. JONES	OUT 19495839514	05:36 00.75
08:20 092 J. SMITH	OUT 18008547226	11:15 00.00
-----AAAAAA-----		

Figure 8.8: Data Filter Example 4

Where **A** represents the first seven characters of the call record field that lists the number dialed.

Assume that you need to only store records for long distance calls. The Data Filter Action would be set at "Store". Since long distance numbers begin with the number 1, Match Parameters would be defined as follows:

**A=1-----**

Where:

- A=1-----** Stores records for calls dialed to any number that begins with a "1", regardless of the remaining six positions.

**Note:** Since this Data Filter uses only the first position of the "A" field, the remaining six positions (specified by the Data Filter Format) must also be accounted for. The wild card operator (-) is used to fill out the remaining six positions in the "A" field.

## 9. The Alarm Filters (Toll Fraud Detection)

---

The Alarm Filters allow the VIP to monitor call records, and check for signs of Toll Fraud or other phone abuse. When suspect calls are detected, the VIP can send an SNMP Trap, contact a local PC via the Console Port, dial a modem or pager or send an Email or Text Message. The Alarm Filter has priority over the Data Filter: even if a call is rejected by the Data Filter, it will still be flagged and stored if it matches an Alarm Clue.

The VIP features two separate Alarm Filters. Each filter has its own format, variables, and alarm criteria. When two dissimilar PBX units are connected to the VIP, this provides a separate Alarm Filter for each. Each Alarm Filter includes a "Format", and one or more "Clues" with associated "Actions". The Format describes the location of specific data items within each call record. Alarm Filter Clues define the criteria that determine whether or not a record will be flagged and counted. "Actions" determine how the VIP will react when an alarm is generated.

### Notes:

- When the VIP is connected to two different types of PBX units, it is recommended to define a separate Alarm Filter for each PBX.
- An Alarm Filter defined for one PBX may not function with another type of PBX.

### 9.1. Common Types of Suspect Phone Activity

---

The first step in the detection of Toll Fraud, is to determine the type of calls you wish to monitor. The following types of calls may provide an indication of potential Toll Fraud:

- Repeated unsuccessful attempts to access voice mail
- After-hours long distance calls
- After-hours calls to your 800 number
- Lengthy international calls
- Calls to countries where you don't normally conduct business

The VIP can also be programmed to monitor calls that can indicate internal phone abuse. Examples of these types of calls are as follows:

- Calls to your competitor's phone number
- Extensions with exceptionally high call activity
- Calls to "900" numbers

All of these call types will have specific characteristics which can be easily recognized when the VIP examines PBX call records.

```

ALARM CONFIGURATION:

ALARMS
1. Alarm Filter 1
2. Alarm Filter 2
3. PBX Inactivity Alarm 1
4. PBX Inactivity Alarm 2
5. 80% Full Alarm:      Off
6. Input Contact Alarm: Off

OUTPUT CONTACTS (IDLE/NO ALARM)
7. Contacts 1/2/3/4:    C/C/C/C

DEFAULT ALARM FILTER ACTION
8. Action:              None
9. Phone #:             (undefined)
   (Cont.):
10. Pager ID 1:         (undefined)
11. Pager ID 2:         (undefined)
12. Pager ID 3:         (undefined)
13. SNMP Mgmt:         Manager #1
14. Output Contacts
   1/2/3/4:             -/-/-/-
15. Message:            (undefined)
   (Cont.):
   (Cont.):
16. Auto Execute:       Off
17. Execute Cmds:       (undefined)
   (Cont.):
   (Cont.):
   (Cont.):
18. Send Alm Records
19. Email to:           Email #1

Enter selection,
Press <ESC> to return to previous menu ...

```

Figure 9.1: Alarm Configuration Menu

## 9.2. The Alarm Configuration Menu

To set-up the Alarm Filters, you must first access the Alarm Configuration Menu. In addition to defining the two Alarm Filters, the Alarm Configuration Menu is also used to access submenus for the PBX Inactivity Alarms, the 80% Full Alarm, and the Input Contact Alarm. The Alarm Configuration Menu is only available in Supervisor Mode.

To access the Alarm Configuration Menu (Figure 9.1) from the Main Menu, type **25** and press **[Enter]**. Items 1 through 6 provide access to submenus for the various alarms. Item 7 selects default settings for the optional output contacts. Items 8 through 17 define Default Alarm Filter Action parameters.

### 9.2.1. Default Alarm Filter Actions

Alarm Action parameters determine how the VIP will react when an alarm is generated. The Default Alarm Filter Actions select parameters that are applied to all newly defined Alarm Clues. This allows the user to assign identical actions to a series of clues without manually entering parameters for each clue.

#### Notes:

- Definition of the Default Alarm Filter Action parameters is optional.
- Default Alarm Action parameters are only applied to newly defined clues. These defaults will not be applied to PBX Inactivity Alarms, 80% Full Alarm, or Input Contact Alarm.
- When new Alarm Clues are defined, the default values can be altered or eliminated, as discussed in Section 9.5.1.



The following Default Alarm Action Parameters are available.

8. **Action:** Specifies the default action that will be performed when an alarm is generated. For more information, please refer to Section 13.
9. **Phone Number:** The default number that will be dialed when an Alarm Clue generates a callout or page action.

**Note:** For Numeric Paging, this prompt can specify both the Pager phone number and a numeric "message". In this case, the phone number is entered in the following format:

**PHONENO@MESSAGENO#**

Where **PHONENO** is the pager number, and **MESSAGENO** is any user-selected number that will notify the receiver that an alarm has occurred. For example, to dial 555-1212 and send the message "111", the phone number would be defined as "**5551212@111#**".

10. **Pager ID 1:** The first default Pager ID number. If alphanumeric pager notification is selected, this is the first pager dialed when an Alarm is triggered. The VIP can dial up to three pagers for each clue.
11. **Pager ID 2:** The second default Pager ID Number.
12. **Pager ID 3:** The third default Pager ID Number.
13. **SNMP Management:** The default SNMP Manager, that will receive SNMP Traps generated by Alarm Clues. IP Addresses for SNMP Managers are defined via the Network Port Configuration Menu, described in Section 5.4.5.
14. **Output Contacts:** The default open/close action that will be performed when an Output Contact action is generated. "C" indicates the contact will be closed, "O" indicates the contact will be opened, and a dash (-) indicates that the status of the contact will not be changed.
15. **Message:** Defines the default message sent when the alarm action is Alphanumeric Page, Numeric Page, SNMP Trap or Console.
16. **Auto Execute:** Sets the default state for the Auto Execute feature. When enabled, the VIP will execute the command string defined under item 17 when a Callout or Console action is generated.

17. **Execute Commands:** The default Auto Execute command string. This command string will be invoked when Auto Execute is enabled, and a Callout or Console Action is generated. The command string consists of a series of ^Bxx commands, which are listed in the Command Help Screen, and Section 19.  
  
**Example:** To send the Site ID Message and then send all alarm records, the Auto Execute Command String would be defined as "**03/01,ALM**". Note that the ^**B** is not included in the command string, and that each command is separated by a slash (/).
  
18. **Send Alarm Record:** Enables and configures the "Send Alarm Record" option for the Alphanumeric Page action. When enabled, the VIP will include the record that triggered the alarm in the text that is sent to your Alphanumeric pager. Please consult your pager service when configuring the Maximum Message Length, Multi-Block Message and Strip Control Codes options.  
  
**Note:** The "Send Alarm Record" function applies to the Alarm Filters only. This function is not available to the PBX Inactivity Alarms or the 80% Full Alarm.
  
19. **Email To:** Determines the default recipient for emails that are generated by the various alarms. This prompt allows you to select either, both or none of the two email recipients that are defined via the Send Email Configuration Menu, as described in Section 5.4.5.1.

```
ALARM FILTER 1:
1. Define Format
2. Display Clue Details
3. Define Clues
4. Edit Clues
5. Delete Clues
6. Alarm Counter Reset Time: (undefined)

Enter selection,
Press <ESC> to return to previous menu ...
```

Figure 9.2: Alarm Filter Configuration Menu (Alarm Filter 1 Shown)

### 9.3. The Alarm Filter Configuration Menus

The Alarm Filter Configuration menus (Figure 9.2) are used to set-up the two Alarm Filters. Each filter has its own configuration menu, and both menus are accessed from the general Alarm Configuration menu (Figure 9.1). Both menus include the following options:

1. **Define Format:** The Alarm filter Format (see Section 9.4.)
2. **Display Clue Details:** This item is used to review the parameters assigned to each Clue.
3. **Define Clues:** The criteria that determine if each record should be flagged and counted. Section 9.5 describes Alarm Clue definition.
4. **Edit Clues:** Allows the user to edit or alter existing Clues.
5. **Delete Clues:** Deletes clues as described in Section 9.5.2.
6. **Alarm Counter Reset Time:** Determines the time of day when Clue Counters for this filter will be reset. Each Clue has a counter which determines how many times this type of call has occurred. For example, a Clue may be used to count long distance calls. When the Alarm Counter Reset Time is selected, all counters for this Alarm Filter will be reset to zero at the selected time each day.

## 9.4. Defining the Alarm Filter Format

---

The Alarm Filter Format describes the location of various "fields" within each call record. Proper definition of the Format tells the VIP where to look, in order to determine if a record should be counted as a match.

Different types of PBX units will produce records with a slightly different structure. In order to define the Alarm Filter Format, you must first examine several records from the PBX in order to determine the exact record structure. After the format is established, the next step is to assign variables to the fields you intend to monitor. The Alarm Filter Format allows definition of up to 26 variables (the uppercase letters A through Z), which indicate specific record fields or locations. These variables are used when defining the Alarm Filter Clues.

When defining the Alarm Filter Format, particular attention must be paid to recognize the exact format used by the PBX. For example, if the call record shows the time as "09:00", then the Alarm Filter Format must account for all five digits, including the colon that separates hours and minutes.

To define the Alarm Filter Format, proceed as follows.

1. Activate the Command Mode as described in Section 19.1. From the Main Menu, type **1** and press **[Enter]** to access the Status Screens. Check the Status Screen for the port you intend to monitor (Port A, Port B, or AUX), and make certain the Time/Date Stamp is Off. The Port Configuration menus are used to enable/disable the Time/Date Stamp as described in Section 5.4.

### Notes:

- If the Time/Date Stamp is On, field locations will be altered when data is released to the polling device. The Time/Date Stamp appends extra characters to each record. This may cause errors in the Alarm Filter Format. Disable this feature prior to storing records that will be used when defining the Alarm Filter Format.
  - After the Alarm Filter Format is defined, make certain to return the Time/Date Stamp option to the desired setting.
2. Press **[Esc]** to return to the Main Menu. Allow the VIP to collect several PBX records.
  3. From the Main Menu, type **25 [Enter]** to access the Alarm Configuration menu. When the menu appears, type **1** or **2** (for Alarm Filter 1 or 2) and press **[Enter]**. The Alarm Filter Configuration menu will appear as shown in Figure 9.2.
  4. From the Alarm Filter Configuration menu, type **1 [Enter]**. The Format Definition menu will appear as shown in Figure 9.3.

```

DEFINE FORMAT:

In order to assist the user during format definition, several data records
and the previous format are displayed below in the following order:

Data Records      (If available)
Previous Format    (If available)

Enter new format at cursor.
<Space><Enter> to clear.
Use upper case letters for fields,
 '-' between fields

|08:16|075|B.JOHNSON      |IN |          |00:55|00.00|
|08:18|067|R.JONES      |OUT|19495839514   |05:36|00.75|
|08:20|092|J.SMITH      |OUT|18008547226   |11:15|00.00|
(undefined)
-----+-----+-----+-----+-----+-----+-----+-----+-----+-----+-----

```

Figure 9.3: Alarm Filter Format Definition Screen

5. The format definition menu will show three sample records, followed by the previous format definition. Although the structure will differ for each PBX, records will look something like those shown in Figure 9.4.
6. **Define the Alarm Filter Format:** The prompt at the bottom of the menu is used to define the Alarm Filter.
  - a) Press the dash key to indicate a field position you do not need to monitor. In Figure 9.4, dashes have been entered in the first four fields of the record.
  - b) When you reach a field that you need to monitor, key in the variable (any uppercase letter) that will be assigned to that position. For example, to assign "A" to the first seven digits of the number dialed, enter seven A's as shown in Figure 9.4. The same variable is repeated for each position in the field.
  - c) When you reach the last position you need to monitor, press **[Enter]**. The VIP will save the Alarm Filter Format and return to the Alarm Filter Configuration menu.

```

DEFINE FORMAT:

In order to assist the user during format definition, several data records
and the previous format are displayed in the following order:

Data Records      (If available)
Previous Format    (If available)

Enter new format at cursor.
<Space><Enter> to clear.
Use upper case letters for fields,
 '-' between fields

|08:16|075|B.JOHNSON      |IN |          |00:55|00.00|
|08:18|067|R.JONES      |OUT|19495839514   |05:36|00.75|
|08:20|092|J.SMITH      |OUT|18008547226   |11:15|00.00|
(undefined)
-----+-----+-----+-----+-----+-----+-----+-----+-----+-----+-----
-----+-----+-----+-----+-----+-----+-----+-----+-----+-----+-----
-AAAAAAAA-----

```

Figure 9.4: Alarm Filter Format Definition Example

## 9.5. Defining the Alarm Filter Clues

---

Alarm Filter Clues describe specific criteria that the VIP will use to determine if each record should be counted as a match. Up to sixteen clues can be defined for each Alarm Filter.

When the Alarm Filter is assigned to an input port, all data received by that port will be monitored. The VIP will scan each record to determine if it matches any of the defined Alarm Clues. Records that match Alarm Clues are flagged and counted. When data is released to the polling device, alarm records can be sorted according to the name of the clue that was matched.

When defining Clues, the following factors should be considered:

- **Clue Name:** Names should describe the type of call the clue will monitor.
- **Threshold Count:** The number of times this type of call must occur in order to generate an alarm.
- **Match Parameters:** The qualities that identify a suspect call. For example, long distance calls are easily recognized because they begin with the number one. Call characteristics are expressed in the form of an equation, which includes the following elements:
  - **Variable(s):** One or more variables from the Alarm Filter Format or one or more Real-Time variables. Variables determine which field(s) will be monitored. For example, the variable may represent the field for the number dialed.
  - **Operator(s):** One or more logical/relational operators, such as  $>$ ,  $<$ , and  $=$  (see Section 9.6).
  - **Parameter(s):** A description of the characteristics that determine whether each record is counted as a match. For example, calls to a specific phone number, or calls made after a specific time.
- **Action Parameters:** A Series of parameters that determine how the VIP will react when the counter for this clue reaches the defined threshold. The VIP can send an SNMP Trap, call a modem or pager, contact the user via the Console Port, open or close the optional Output Contacts or send an Email or Text Message. For more information on Alarm Actions, please refer to Section 13.

**Note:** The Output Contact option is not available on NLJ-VIP units.

```

DEFINE OR EDIT CLUE:

1. Clue Name:          (undefined)      21. Email to:      Email #1
2. Threshold:         0
3. Match Parameters:  (undefined)
   (Cont.):
4. Action:            None
5. Phone #:          (undefined)
6. Pager ID 1:       (undefined)
7. Pager ID 2:       (undefined)
8. Pager ID 3:       (undefined)
9. SNMP Mgmt:        Manager #1
10. Output Contacts
    1/2/3/4:          -/-/-/
11. Message:         (undefined)
12. Auto Execute:    Off
13. Execute Cmds:    (undefined)
   (Cont.):
14. Send Alarm Records

Enter selection,
Press <ESC> to return to previous menu ...

```

Figure 9.5: Alarm Clue Definition Menu

### 9.5.1. Alarm Clue Definition

To define Alarm Clues, access the Alarm Clue Definition Menu (Figure 9.5) as follows:

1. From the VIP Main Menu, type **25** and press **[Enter]** to display the Alarm Configuration Menu (Figure 9.1).
2. When the Alarm Configuration Menu appears, type **1** (to configure Alarm Filter 1) or **2** (Alarm Filter 2), and then press **[Enter]**. The Alarm Filter Configuration Menu (Figure 9.2).
3. From the Alarm Filter Configuration Menu, type **3** and press **[Enter]**. The Alarm Clue Definition Menu (Figure 9.5) will appear.

As described in Section 9.2, from the Alarm Filter Configuration menu, type **3** and press **[Enter]**. The Alarm Clue Definition menu will be displayed as shown in Figure 9.5.

The Alarm Clue Definition Menu includes the following:

1. **Clue Name:** This name is used to reference a specific clue when reviewing, altering, or deleting clues. When data is released, records can also be sorted according to the Clue Name matched. Names can be up to 16 characters long, and cannot include <Esc>, <Null>, or quotation marks.
2. **Threshold:** The number of times this type of call must occur in order to trigger an alarm. This value can be any positive whole number from zero to 999,999,999.

3. **Match Parameters:** Defines criteria that determine if each record will be flagged as an alarm. Match Parameters consist of a variable from Alarm Filter Format, a logical operator (see Section 9.6,) and the value that will be matched (e.g. the number dialed).  
**Example:** If the Alarm Filter Format assigns the variable "A" to the "Number Dialed" field, then A=5551212 tells the VIP to check this field for the number 555-1212.  
**Note:** Match Parameters may reference several variables, may include several operators, and may also include "AND/OR" conditions. Please refer to the examples in Section 9.9.
4. **Action Parameters (Items 4 - 13):** These items determine how the VIP will react when the counter for this clue exceeds the threshold value. If default Alarm Filter Action parameters have been defined (Section 9.2.1) each prompt will be configured according to the default. Action Parameters for each Clue can be individually defined, and parameters specified by defaults can also be edited. This allows you to assign different Pager Numbers and etc. to each clue. For more information, please refer to Section 13.

### 9.5.2. Editing and Deleting Clues

The Alarm Filter Configuration menu is used to edit, delete or display parameters defined for each clue.

1. From the Main Menu, type **25** and press **[Enter]**. The Alarm Configuration Menu will be displayed.
2. From the Alarm Configuration Menu, type **1** (for Alarm Filter 1) or **2** (for Alarm Filter 2) and then press **[Enter]**. The Alarm Filter Configuration Menu (Figure 9.2) will be displayed.
3. **Display Clue Details:** To review parameters assigned to each clue, type **2** and press **[Enter]**. The VIP will list all clue names for this Alarm Filter. Key in the name of the desired clue and press **[Enter]**; parameters for the specified clue will be displayed.
4. **Edit Clues:** To alter an existing Clue, type **4** and press **[Enter]**. The VIP will list all clues defined for this Alarm Filter. Key in the name of the desired clue and then press **[Enter]**. The Define/Edit Clue menu will be displayed.
5. **Delete Clues:** To delete an existing Clue, type **5** and press **[Enter]**. The VIP will list all clues defined for this Alarm Filter. Key in the name of the clue that you wish to delete and then press **[Enter]**. The clue will be deleted.

**Note:** Deleted Alarm Clues cannot be recovered.



## 9.6. Logical and Relational Operators

Variables and operators are combined to form match parameters. Variables are the uppercase letters A through Z, as defined in the Alarm Filter Format. Relational and logical operators are described below.

Operator	Function
>	Greater Than
<	Less Than
>=	Greater Than or Equal To
<=	Less Than or Equal To
~	Not. Can also precede other comparison operators (e.g. ~<, Not Less Than).
=	Equal To
\$	Contains String. Searches for specified string anywhere in a field
-	(Dash) Wild Card Character
()	(Parentheses) Used to Combine and Prioritize Operations
+ or	Logical OR Conditions
* or &	Logical AND Conditions

### 9.6.1. Logical AND/OR Conditions

Logical AND/OR conditions are created by including the AND operators, or the OR operators in the Match Parameter definition.

#### 9.6.1.1. Logical AND Conditions

The AND operators (\* and &) link parameters in a manner where two or more conditions must all be true in order for the call record to be flagged and counted.

**Example:** Assume the variable "A" represents the field for the number dialed, and "B" represents the extension number. To define an Alarm Clue that counts calls placed to 555-1111 from extension 013, match parameters would be defined as follows:

**A=5551111\*B=013 or A=5551111&B=013**

This Alarm Filter Clue would *only* count calls that are placed to 555-1111 AND placed from extension 013. Calls to 555-1111 from extension 086 would *not* be counted, and calls to 555-2222 from extension 013 would also *not* be counted.

### 9.6.1.2. Logical OR Conditions

The OR operators (+ and |) link parameters in a manner where any of two or more conditions must be true in order for the call record to be counted.

**Example:** Assume the variable "A" represents the field for the number dialed, and "B" represents the extension number. To define an Alarm Clue that counts calls placed to 555-1111, OR placed from extension 013, match parameters would be defined as follows:

**A=5551111+B=013 or A=5551111|B=013**

This Alarm Clue would count all calls that are placed to 555-1111 OR placed from extension 013. Calls to 555-1111 from extension 086 would be counted, and calls to 555-2222 from extension 013 would also be counted.

### 9.6.2. The "Contains String" Operator

The "Contains String" Operator (\$) allows the VIP to search an entire variable field for a given value or text string, without regard for the item's position within the field.

For example, assume the variable "A" represents the first eleven characters in the field for the number dialed as shown in Figure 9.6. If Match Parameters are defined as "A\$714", then the VIP will search all eleven "digits" of the phone number for the value "714". This Alarm Clue would count any record that contains the string 714 anywhere in the phone number. This would include records where 714 was the area code, and records where 714 was a part of the number dialed.

08:16 075 B. JOHNSON	OUT 17145551212	00:55 00.00
08:18 067 R. JONES	OUT 19495557714	05:36 00.75
08:20 092 J. SMITH	OUT 18007140000	11:15 00.00
-----AAAAAAAAA-----		

Figure 9.6: Alarm Filter Format; "Contains String" Example

## 9.7. Real Time Variables

Alarm Filter Clues can also include Real-Time variables that monitor the VIP's internal clock and calendar.

Real-Time variables do not use the Alarm Filter Format, or monitor the contents of the call record. When Real-Time variables are used, the VIP will check its internal clock and calendar as each call record is received. If the time and/or date matches the Clue definition, the call is flagged and counted. The VIP's internal clock, rather than the contents of the call record, determines whether the record is counted. The following Real-Time variables can be used to monitor the internal clock and calendar.

**Note:** Real Time variables are always entered as lowercase characters.

- t Time:** Tells the VIP to determine the time each record is received. The time is entered in "HH:MM" format, where HH is the hour (00 - 23), and MM is the minute (00 - 59).
- w Day of the Week:** Tells the VIP to determine the day of the week when the record is received. The day of the week is entered as a single digit, where 1 = Sunday, 2 = Monday, 3 = Tuesday, 4 = Wednesday, 5 = Thursday, 6 = Friday, and 7 = Saturday.
- d Date:** Tells the VIP to determine the date the record is received. The date is entered in "MM/DD" format, where MM is the month (01 - 12) and DD is the date (01 - 31).

**Example 1:** To create an Alarm Filter Clue that will count call records received on Sunday, match parameters would be defined as **w=1**. Where **w** is the Real-Time variable for the day of the week, and **1** indicates Sunday.

**Example 2:** To create an Alarm Filter Clue that will count call records received after 6:00 pm (18:00) or before 7:00 am (07:00), match parameters would be defined as follows:

**t>18:00+t<07:00**

Where **t** is the Real-Time variable for the time, and **+** is the logical OR.

### Notes:

- Real-Time variables are not defined in the filter format.
- The match parameter definition can include both Real-Time variables and regular variables, as well as logical and relational operators.
- Real-Time variables function independently from the Time/Date Stamp. The Time/Date Stamp does not have to be enabled in order for the Real-Time variables to function.
- Values from the internal clock/calendar are not included in the call record, unless the Time/Date Stamp is enabled.

## 9.8. Assigning the Alarm Filter to a Port

---

After defining the Alarm Filter, the next step is to assign the filter to one or more input ports. The Port Configuration menus are used to assign one of the available Alarm Filters to each port as described in Section 5.4. Note that Alarm Filters will not function until they are assigned to a port.

## 9.9. Match Parameter Definition Examples

---

The following examples are based on fictional PBX call record formats. When designing your Alarm Filter, be aware that the record structure will differ from those shown in the examples. When defining the Alarm Filter Format and Match Parameters the following factors must be considered:

- **Exact Match:** Alphanumeric values in parameter definitions must exactly match those found in the call record. If the record shows the time as "09:00", then the match parameters must also list the time as "09:00", and not "0900" or "9:00".
- **Number of Characters:** For any given variable, the number of characters specified in the Alarm Filter Format must exactly match the number of characters indicated in the Match Parameters definition. For example, if the filter format defines the variable "B" as the first seven characters of the number dialed, then the parameter definition must account for all seven characters.
- **Searching for Operator Characters:** When searching for a text string which contains a space or any character that is also one of the VIP's operators (e.g. >, <, or &) a backslash (\) must precede the space or operator. For example, to search for "\*\*\*Error\*\*\*", the match parameter would be defined as "\\\*\\\*\\\*Error\\\*\\\*\\\*". Likewise, when searching for "hello there", the match parameter would be defined as "hello\\ there".
- **Variable Case:** When defining and using variables, take care to use the correct case. Real Time variables are always entered as lowercase characters; regular variables are always entered as uppercase characters.

08:18 001 VMAIL	IN	00:20 00.00
08:20 092 J.SMITH	OUT 18008547226	01:07 01.30
08:21 001 VMAIL	IN	00:15 00.00
-AAAAA-BBB-CCCC	-----DDDDDD-----	-----EEEE-----

Figure 9.7: Alarm Filter Format; Match Parameters Example 1

### **Example 1: Repeated Attempts to Access Voice Mail**

This Alarm Clue counts short calls to voice mail. This type of call could indicate that a caller is dialing into voice mail and randomly trying access codes in an attempt to find an outside line.

For this example, assume the Alarm Filter Format is defined as shown in Figure 9.7. Note that the first three lines in Figure 9.7 are sample call records, and the fourth line is the Alarm Filter Format. The variables A, B, and D are not used for this clue.

Where:

**CCCCC** is the first five characters of the username.

**EEEE** is the field that lists the call duration.

Match Parameters for this Alarm Clue would be defined as follows:

**C=VMAIL\*E<=00:30**

Where:

**C=VMAIL** Counts calls with "VMAIL" in the username field.

**\*** is the logical "AND" operator.

**E<=00:30** Tells the VIP to count calls which last 30 seconds or less.

19:18 067 R. JONES	OUT 12145551234	25:36 04.75
19:20 092 J. SMITH	OUT 18008547226	01:07 00.00
21:21 002 R. JONES	OUT 12135551212	30:15 05.75
-AAAAA-BBB-CCCC-----	DDDDDD-----	-----EEEE-----

Figure 9.8: Alarm Filter Format; Match Parameters Example 2

**Example 2: After Hours Long Distance Calls.**

This clue counts long distance calls placed after 6:00 pm and before 7:00 am. This type of call could indicate that a hacker has obtained an access code for an outside line and is using the line to dial long distance numbers after work hours.

For this example, assume the Alarm Filter Format is defined as shown in Figure 9.8. Note that the first three lines in Figure 9.8 are sample call records, and the fourth line is the Alarm Filter Format. The variables B, C, and E are not used for this clue.

Where:

- A** is the time the call was received or placed.
- D** is the first seven digits of the number dialed.

Match Parameters for this Alarm Clue would be defined as follows:

**(A>18:00+A<07:00) \*D=1-----**

Where:

**(A>18:00+A<07:00)**

Counts calls placed after 18:00 or before 07:00.

**\*** is the logical AND operator.

**D=1-----** Counts calls where the first digit of the number dialed is "1". Note that the remaining 6 digits are entered as wild card characters (-).

17:28 067 T.WILLIAMS	OUT 011811234567	45:36 20.75
17:20 092 J.SMITH	OUT 18008547226	01:07 00.00
17:21 002 P.BROWN	OUT 19495839514	00:57 00.20
-AAAAA-BBB-CCCC-----	-DDDDDD-----	-EEEE-----

Figure 9.9: Alarm Filter Format; Match Parameters Example 3

### Example 3: Lengthy International Calls

This clue requires that you are familiar with the average duration of international calls placed in the course of a normal day. For example, if your average international call lasts about 10 minutes, and you are suddenly billed for a two hour call, this could indicate phone abuse.

For this example, assume that the Alarm Filter Format is defined as shown in Figure 9.9. Note that the first three lines in Figure 9.9 are sample call records, and the fourth line is the Alarm Filter Format. The variables A, B, and C are not used for this clue.

Where:

- D** is the field that lists the first seven digits of the number dialed.
- E** is the field that lists the call duration.

Match Parameters for this Alarm Clue would be defined as follows:

**D=011-----\*E>=20:00**

Where:

- D=011-----** Counts calls where the first three digits of the number dialed are "011". The remaining 4 digits are entered as wild card characters (-).
- \*** is the logical AND operator.
- E>=20:00** Counts calls that last 20 minutes or longer.

```
|08:18|067|R.JONES      |OUT|          5553333|05:36|00.75|
|08:20|091|R.PETERS    |OUT|          19005551212|31:07|41.00|
|08:21|002|P.BROWN     |OUT|  1900555444411#2|00:57|00.20|
-----A$1900-----
```

Figure 9.10: Alarm Filter Format; Match Parameters Example 4

### **Example 4: The "Contains String" Operator (\$)**

This clue provides an example of how the "Contains String" operator (\$) can search a field for a specific text string, without regard for the string's position within the field. This is useful in cases where the call record includes a field with right justified numbers (e.g. the number dialed).

For this example, assume that the Alarm Filter Format is defined as shown in Figure 9.10. Note that the first three lines in Figure 9.10 are sample call records, and the fourth line is the Alarm Filter Format.

Where **A** is the field that lists the number dialed.

In this example, the PBX also records digits entered after the call has connected. This is often seen in cases where the caller is prompted to press numbers in order to access a specific department or extension. In the third line of the example, the digits "11#2" represent digits entered after the call was connected.

Match Parameters for this Alarm Clue would be defined as follows:

**A\$1900**

Where A\$1900 tells the VIP to count calls that have the string "1900" anywhere in the "A" field. When the "\$" operator is used, wild card characters are not used to fill the remaining digits.

**Note:** When the "Contains String" operator is used, the clue may also count call records that do not fit the intended purpose of the clue. For example, the clue in this example would also count calls to any number that contains the string "1900", such as "555-1900".



## 10. PBX Inactivity Alarms

---

The PBX Inactivity Alarms allow the VIP to provide notification in the event of PBX failure or disconnection. If the VIP does not receive PBX data for a user-defined period of time, an alarm will be generated, allowing you to investigate as quickly as possible.

The VIP features two separate PBX Inactivity Alarms. When the VIP is connected to more than one PBX unit, this allows the user to define two alarm schedules, and apply the most appropriate schedule to each PBX. Each PBX Inactivity Alarm includes four schedules with associated timers; two for weekdays and two for weekends, as summarized below:

- **PBX Inactivity Alarm 1**
  - Weekday Alarm
    - Weekday Schedule/Timer 1 (For Busy Periods)
    - Weekday Schedule/Timer 2 (For Slow Periods)
  - Weekend Alarm
    - Weekend Schedule/Timer 1 (For Busy Periods)
    - Weekend Schedule/Timer 2 (For Slow Periods)
- **PBX Inactivity Alarm 2**
  - Weekday Alarm
    - Weekday Schedule/Timer 1 (For Busy Periods)
    - Weekday Schedule/Timer 2 (For Slow Periods)
  - Weekend Alarm
    - Weekend Schedule/Timer 1 (For Busy Periods)
    - Weekend Schedule/Timer 2 (For Slow Periods)

### 10.1. Schedules and Timers

---

In order to allow the VIP to differentiate between periods when less PBX activity is expected (e.g. lunch hour), and periods where a lack of activity could indicate a problem, each PBX Inactivity Alarm has two weekday schedules and two weekend schedules.

During any business day, there are periods when one can expect a lower level of PBX traffic. For example, the PBX may receive about one call every five minutes for the majority of the day, and then drop to one call every 30 minutes during lunch hour. Likewise, on weekends the number of calls may also decline.

Two separate weekday schedules allow you to specify slow and heavy PBX activity periods during the work week; the two weekend schedules allow you to define slow and heavy periods on weekends. In both cases, Schedule 1 is assigned to the busy period, and Schedule 2 is assigned to the slow period. Note that Schedule 2 has priority over Schedule 1, and timer schedules are often defined to overlap.

In order to prevent the VIP from generating PBX Inactivity Alarms on holidays, up to 20 user defined holidays (exclusions) can be defined. This allows the alarm to be suppressed on holidays, or on any other day when you expect low PBX activity.

**Example:** If you receive one call every five minutes from 8:00 am to 5:00 pm, Timer One would be set for five minutes and Schedule One would be defined as 08:00 to 17:00. In order to compensate for a drop in activity to one call every 30 minutes during lunch, Timer Two would be set for 30 minutes and Schedule Two would be defined as 12:00 to 13:00.

## **10.2. Enabling the PBX Inactivity Alarm**

---

Access Command Mode. From the Main Menu, type **25 [Enter]**. When the Alarm Configuration menu appears, type **3 [Enter]** for PBX Inactivity Alarm 1, or **4 [Enter]** for PBX Inactivity Alarm 2. The screen shown in Figure 10.1 will appear, allowing you to define the following:

**Schedule:** Defines the schedules and timers for busy and slow portions for weekdays and weekends.

1. **Weekday Alarm:** Enables/disables the Weekday Schedule.
2. **Weekday Schedule 1:** The weekday time period when you expect the highest level of PBX traffic. This period will be monitored by Weekday Timer 1. Enter the time using 24 hour (military) format.
3. **Weekday Timer 1:** The maximum time that may elapse between calls while Weekday Schedule 1 is active. (01 to 99 minutes).
4. **Weekday Schedule 2:** The weekday time period when you expect the lowest level of traffic. This time period will be monitored by Weekday Timer 2. Enter the time using 24 hour (military) format.
5. **Weekday Timer 2:** The maximum time that may elapse between calls while Weekday Schedule 2 is in effect. (01 to 99 minutes).
6. **Weekend Alarm:** Enables/disables the Weekend Alarm Schedule.

PBX INACTIVITY ALARM 1:			
SCHEDULE		ALARM ACTION PARAMETERS	
1. Weekday Alarm:	Off	13. Action:	None
2. Weekday Schedule 1:	00:00-00:00	14. Phone #:	(undefined)
3. Weekday Timer 1:	00:00	(Cont.):	
4. Weekday Schedule 2:	00:00-00:00	15. Pager ID 1:	(undefined)
5. Weekday Timer 2:	00:00	16. Pager ID 2:	(undefined)
6. Weekend Alarm:	Off	17. Pager ID 3:	(undefined)
7. Weekend Schedule 1:	00:00-00:00	18. SNMP Mgmt:	Manager #1
8. Weekend Timer 1:	00:00	19. Output Contacts	
9. Weekend Schedule 2:	00:00-00:00	1/2/3/4:	-/-/-/-
10. Weekend Timer 2:	00:00	20. Message:	(undefined)
EXCLUSIONS (MM/DD)		(Cont.):	
--/--	--/--	--/--	--/--
--/--	--/--	--/--	--/--
--/--	--/--	--/--	--/--
--/--	--/--	--/--	--/--
--/--	--/--	--/--	--/--
11. Add Exclusion		21. Auto Execute:	Off
12. Delete Exclusion		22. Execute Cmds:	(undefined)
		(Cont.):	
		(Cont.):	
		(Cont.):	
		23. Email to:	Email #1
Enter selection, Press <ESC> to return to previous menu ...			

Figure 10.1: PBX Inactivity Alarm Set-Up Menu (Alarm 1 Shown)

7. **Weekend Schedule 1:** The weekend time period when you expect the highest level of traffic. This time period will be monitored by Weekend Timer 1. Enter the time using 24 hour (military) format.
8. **Weekend Timer 1:** The maximum time that may elapse between calls while Weekend Schedule 1 is active. (01 to 99 minutes).
9. **Weekend Schedule 2:** The weekend time period when you expect the lowest level of PBX activity. This period will be monitored by Weekend Timer 2. Enter the time using 24 hour (military) format.
10. **Weekday Timer 2:** The maximum time that may elapse between calls while Weekend Schedule 2 is in effect. (01 to 99 minutes).

**Exclusions:** Defines holidays or other days when there will be little or no PBX activity. The PBX Inactivity Alarm will be suppressed on these days. Exclusions will be displayed on the lines above item 11.

11. **Add Exclusions:** Defines holidays and other excluded days using MM/DD format. To define exclusions, type **11**, press **[Enter]** and follow the instructions in the submenu.
12. **Delete Exclusions:** Deletes days from the exclusion list. To delete a holiday, type **12** **[Enter]** and follow instructions in the submenu.

**Actions:** Determines how the VIP will react when a PBX Inactivity Alarm is generated. The VIP can call a remote modem or pager, send an SNMP Trap, execute user-defined commands, send a message via the console port, open or close the optional Output Contacts or send an Email or Text Message. Note that the Output Contact option is not available on NLJ-VIP units.

13. **Action:** The type of action that will be performed when a PBX Inactivity Alarm is generated; None, Callout, Alphanumeric Page, Numeric Page, SNMP Trap, Output Contact, and Console. For more information, please refer to Section 13.

14. **Phone Number:** The number dialed for a callout or page.

**Note:** For Numeric Paging, this prompt can specify both the pager number and a numeric "message", as follows:

**PHONENO@MESSAGENO#**

Where **PHONENO** is the phone number, and **MESSAGENO** is any user-selected number which will notify the receiver that an alarm has occurred. For example, to dial 555-1212 and send the message "123", item 14 would be defined as "**5551212@123#**".

15. **Pager ID 1:** The first Pager ID number dialed for an alphanumeric page. The VIP can dial up to three pagers for each inactivity alarm.

16. **Pager ID 2:** The second Pager ID Number for this Alarm.

17. **Pager ID 3:** The third Pager ID Number for this Alarm.

18. **SNMP Management:** The network manager that will receive SNMP Traps generated by this alarm. This selects one, both or none of two available SNMP Managers. The IP addresses for each manager are defined via the Network Port Configuration Menu.

19. **Output Contacts:** The open/close operation performed by the optional Output Contacts when this alarm generates an Output Contact action. "C" indicates the Output Contact will close when an alarm is generated, "O" indicates the contact will open, and a dash (-) indicates that the status of the contact will not be changed.

20. **Message:** The message that is sent when a Callout, Alphanumeric Page, SNMP Trap, Console action or Email/Text Message is generated by this alarm.

21. **Auto Execute:** If enabled, the VIP will execute the command string defined under item 22 when a callout or console action is generated by this alarm.
22. **Execute Commands:** The command string performed when the Auto Execute feature is enabled, and a callout or console action is generated. This command string consists of a series of ^Bxx commands, which are listed in the Command Help Screen, and discussed further in Section 19. For more information, please refer to Section 13.3. (Up to 64 characters; **Default = undefined**).

**Example:** To send the Site ID Message and then send all alarm records, the Auto Execute Command String would be defined as "03/01 ,ALM".

**Notes:**

- When the Auto-Execute string is defined, commands are entered without the ^B character, and each individual command is separated by a slash character.
  - In order for the Auto Execute feature to function, item 21 must be enabled, the command string must be defined under item 22, and the action must be set at either Callout or Console.
23. **Email To:** This item is used to select the recipient(s) for emails that are generated by this alarm. The submeu for this prompt allows you to select either, both or none of the two email recipients that are defined via the Send Email Configuration Menu, as described in Section 5.4.5.1. (**Default = Email #1.**)



## 11. The 80% Full Alarm

---

The 80% Full Alarm is designed to notify the user when internal memory becomes approximately 80% Full. The VIP can send an SNMP Trap, call a modem or pager, or contact the user via the Console Port. This Alarm can also execute a user-defined command string or open/close the optional Output Contacts.

To configure the alarm, go to the Main Menu. Type **25** and press **[Enter]** to access the Alarm Configuration menu. When the menu appears, type **5** and press **[Enter]**. The 80% Full Alarm Configuration Menu (Figure 11.1) offers the following options:

1. **80% Full Alarm:** Enables/disables the 80% Full Alarm. In order to function, the alarm must be enabled.
2. **Action:** Determines how the VIP will react when an 80% Full Alarm is generated. The options are None, Callout, Alphanumeric Page, Numeric Page, SNMP Trap, Output Contact, Console action or Email/Text Message. For more information, please refer to Section 13. Note that the Output Contact feature is optional on NetLink-VIP units, and is not available on NLJ-VIP units.
3. **Phone Number:** The number dialed for a callout or page.  
**Note:** For Numeric Paging, this prompt can specify both a phone number and numeric "message". In this case, the number is entered as follows:

**PHONENO@MESSAGENO#**

Where **PHONENO** is the pager number, and **MESSAGENO** is any number that notifies the user that an alarm has occurred. For example, to dial 555-1212 and send the message "999", item 3 would be defined as "**5551212@999#**".

4. **Pager ID 1:** The first Pager ID Number dialed for an Alphanumeric Page action. The VIP can dial up to three pagers for this alarm.
5. **Pager ID 2:** The second Pager ID Number for the 80% Full Alarm.
6. **Pager ID 3:** The third Pager ID Number for the 80% Full Alarm.
7. **SNMP Management:** The network manager that will receive SNMP Traps generated by this alarm. This item selects one, both or none of the two available SNMP Managers. IP Addresses for these SNMP Managers are defined via the Network Port Configuration Menu.

```
80% FULL ALARM:

1. 80% Full Alarm:      Off
2. Action:              None
3. Phone #:             (undefined)
4. Pager ID 1:          (undefined)
5. Pager ID 2:          (undefined)
6. Pager ID 3:          (undefined)
7. SNMP Mgmt:           Manager #1
8. Output Contacts
  1/2/3/4:              -/-/-/
9. Message:              (undefined)
10. Auto Execute:       Off
11. Execute Cmds:       (undefined)
    (Cont):
12. Email to:           Email #1

Enter selection,
Press <ESC> to return to previous menu ...
```

Figure 11.1: The 80% Full Alarm Configuration Menu

8. **Output Contacts:** (Optional) Defines the open/close operation that will be performed by the optional Output Contacts when this alarm generates an Output Contact action. An "O" indicates the contact will be opened, "C" indicates the contact will be closed, and a dash (-) indicates that the status of the contact will not be changed.
9. **Message:** The message sent when a Callout, Alphanumeric Page, SNMP Trap or Console action is generated.
10. **Auto Execute:** If enabled, the VIP will execute the command string defined under item 11 when a Callout or Console action is generated by this alarm.
11. **Execute Commands:** The Auto-Execute command string. This command string consists of a series of ^Bxx commands with each command separated by a backslash and forward slash character (e.g. \**03**\/**01**). ^Bxx commands are discussed further in Section 19. For more information, please refer to the example in Section 13.3. (Up to 64 characters; **Default = undefined.**)  
**Note:** In order for Auto Execute to function, item 10 must be enabled, the command string must be defined, and either a Callout or Console action must be selected.
12. **Email To:** This item is used to select the recipient(s) for emails that are generated by this alarm. The submenu for this prompt allows you to select either, both or none of the two email recipients that are defined via the Send Email Configuration Menu, as described in Section 5.4.5.1. (**Default = Email #1.**)



## 12. The Input Contact Alarms

---

The Input Contact Alarms are used to monitor the optional Input Contacts. When the High/Low status of the input signal changes, the VIP can send an SNMP Trap, call a modem or pager, or contact the user via the Console Port. In addition, this alarm can also automatically execute a user-defined command string, or open/close the Output contacts.

**Note:** The Input Contact Alarm feature is optional on NetLink-VIP units, and is not available on NLJ-VIP units.

### 12.1. The Optional I/O Monitor

---

When the optional I/O Monitor is present, the NetLink-VIP will include two extra components on the instrument back panel; a bank of Input Contacts, and a bank of Output Contacts.

The Input Contacts are designed for connection to an externally supplied signal line. When a change in the high/low status is detected, the NetLink-VIP can perform any of the standard Alarm Actions described in Section 13.

The Output Contacts are used to switch a connected device On or Off. Alarm Actions for the Alarm Filters, PBX Inactivity Alarm, 80% Full Alarm and Input Contact Alarms all provide the option of switching the Output Contacts. The general Alarm Configuration menu is used to select the idle (non-alarm) state for the Output Contacts.

To select the Idle (Non-Alarm) state for the Output Contacts, proceed as follows:

1. From the Main Menu, type **24** and press **[Enter]** to access the general Alarm Configuration menu (Figure 12.1).
2. When the Alarm Configuration menu appears, type **7** and press **[Enter]** to access the Output Contacts submenu.
3. From the Output Contacts submenu, the user may select the Idle/ Non-Alarm state for the Output Contacts. Each Output Contact can be configured to be Opened or Closed under normal (non-alarm) circumstances.

```

ALARM CONFIGURATION:

ALARMS
1. Alarm Filter 1
2. Alarm Filter 2
3. PBX Inactivity Alarm 1
4. PBX Inactivity Alarm 2
5. 80% Full Alarm:      Off
6. Input Contact Alarm: Off

OUTPUT CONTACTS (IDLE/NO ALARM)
7. Contacts 1/2/3/4:    C/C/C/C

DEFAULT ALARM FILTER ACTION
8. Action:              None
9. Phone #:             (undefined)
   (Cont.):
10. Pager ID 1:         (undefined)
11. Pager ID 2:         (undefined)
12. Pager ID 3:         (undefined)
13. SNMP Mgmt:         Manager #1
14. Output Contacts
   1/2/3/4:             -/-/-/-
15. Message:            (undefined)
   (Cont.):
   (Cont.):
16. Auto Execute:       Off
17. Execute Cmds:      (undefined)
   (Cont.):
   (Cont.):
   (Cont.):
18. Send Alm Records
19. Email to:           Email #1

Enter selection,
Press <ESC> to return to previous menu ...
    
```

Figure 12.1: The Alarm Configuration Menu

## 12.2. Configuring the Input Contact Alarm

To access the Input Contact Alarm configuration menus from the Main Menu, first type **25** and press **[Enter]** to access the general Alarm Configuration menu (Figure 12.1). From the Alarm Configuration Menu, type **6** and press **[Enter]** to access the Input Contact Alarm selector screen.

The selector screen lists the On/Off status of the four available Input Contact Alarms, and provides access to the configuration menu for each alarm. To access the configuration menus, key in the number for the desired alarm, and press **[Enter]**. The configuration menu will be displayed as shown in Figure 12.2.

The alarm configuration menus offer the following options:

1. **Contact Alarm:** This item enables/disables the Input Contact Alarm for the corresponding Input Contact. **(Default = Off.)**
2. **Trigger Level:** Determines whether an alarm will be generated if the contact circuit goes Low or if the contact circuit goes High. **(Default = Low.)**
3. **Action:** Determines how the VIP will react when an Input Contact Alarm is generated by this contact. The available options are None, Callout, Alphanumeric Page, Numeric Page, SNMP Trap, Output Contact, Console action or Email/Text Message. For more information, please refer to Section 13. **(Default = None.)**

```

INPUT CONTACT 1 ALARM:

1. Contact Alarm:      Off
2. Trigger Level:     Low
3. Action:             None
4. Phone:              (undefined)
5. Pager ID 1:         (undefined)
6. Pager ID 2:         (undefined)
7. Pager ID 3:         (undefined)
8. SNMP Mgmt:         Manager #1
9. Output Contacts
  1/2/3/4:             -/-/-/
10. Message:           (undefined)
11. Auto Execute:     Off
12. Execute Cmds:     (undefined)
    (Cont.):
13. Email to:         Email #1

Enter selection,
Press <ESC> to return to previous menu ...

```

Figure 12.2: Input Contact Alarm Configuration Menu (Contact 1 Shown)

4. **Phone Number:** The number dialed when a callout or page is generated by this alarm. **(Default = undefined.)**

**Note:** For Numeric Paging, this prompt can specify both a pager number and a numeric "message". In this case, the phone number is entered as follows:

**PHONENO@MESSAGENO#**

Where **PHONENO** is the pager phone number, and **MESSAGENO** is any number that will notify the user when an alarm occurs. For example, to dial 555-1212 and send the message "88", item 3 would be defined as "**5551212@88#**".

5. **Pager ID 1:** The first Pager ID Number dialed when an alphanumeric Pager action is generated by this alarm. The VIP can dial up to three pagers for each contact alarm. **(Default = undefined.)**
6. **Pager ID 2:** The second Pager ID Number for this Input Contact Alarm. **(Default = undefined.)**
7. **Pager ID 3:** The third Pager ID Number for this Input Contact Alarm. **(Default = undefined.)**
8. **SNMP Management:** The network manager that will receive SNMP Traps generated by this alarm. This item selects one, both or none of the two SNMP Managers. IP Addresses for the SNMP Managers are defined via the Network Port Configuration Menu. **(Default = Manager #1.)**

9. **Output Contacts:** The open/close action that will be performed when an Output Contact action is generated by this alarm. A "C" indicates the contact will be closed, "O" indicates the contact will be opened, a dash (-) indicates the status of the contact will not be changed. **(Default = No Action.)**
10. **Message:** The message that will be sent when a Callout, Alphanumeric Page, SNMP Trap, Console action or Email/Text Message is generated by this alarm. **(Default = undefined.)**
11. **Auto Execute:** If enabled, the VIP will execute the command string defined under item 11 when a Callout or Console action is generated by this alarm. **(Default = Off.)**
12. **Execute Commands:** Defines the command string that will be performed if Auto Execute is enabled, and a Callout or Console Action is generated by this alarm. This command string consists of a series of ^Bxx commands, with each command separated by a backslash and forward slash character (\/). ^Bxx commands are discussed in Section 19. For more information, please refer to Section 13.3. **(Default = undefined.)**

**Example:** To send the Site ID Message and then send all alarm records, the Auto Execute String would be defined as "`\/03\/01,ALM`".

**Notes:**

- When the Auto-Execute string is defined, commands are entered without the ^B character, and each individual command is separated by a slash character.
  - In order for the Auto Execute feature to function, item 10 must be enabled, the command string must be defined under item 11, and the Alarm Action must be set at either Callout or Console.
13. **Email To:** This item is used to select the recipient(s) for emails that are generated by this alarm. The submeu for this prompt allows you to select both, either or none of the two email recipients that are defined via the Send Email Configuration Menu, as described in Section 5.4.5.1. **(Default = Email #1.)**

## 13. Alarm Actions

---

When an alarm is generated, the VIP can call a modem or pager, send an SNMP Trap, contact the user via the Console Port, send an email or test message, or switch the optional Output Contacts. These tasks are referred to as "Alarm Actions". Note that the Output Contact option is not available on NLJ-VIP units.

The Alarm Actions discussed in this chapter can be applied to Toll Fraud Alarms, PBX Inactivity Alarms, the 80% Full Alarm, or the Input Contact Alarms. In addition, the VIP can also perform these Alarm Actions according to a user-defined schedule, as described in Section 14.

The configuration menu for each individual alarm is used to select the specific action that will be performed when the alarm is triggered. The alarm configuration menus offer the following Alarm Actions:

- **None:** When an alarm is generated, the VIP will not attempt to contact the user, or open or close the Output Contacts. Call records will continue to be flagged, counted and sorted.
- **Callout:** When an alarm is generated, the VIP will call a user-specified modem number in order to download data or report conditions.
- **Alphanumeric Page:** When an alarm is generated, the VIP will dial up to three alphanumeric pagers.
- **Numeric Page:** When an alarm is generated, the VIP will dial one numeric pager.
- **SNMP Trap:** When an alarm is generated, the VIP will send an SNMP Trap to the selected SNMP manager.
- **Output Contact:** When an alarm is generated, the VIP will open or close the optional Output Contacts. Note that the Output Contacts are an optional feature, and are not available on NLJ-VIP units.
- **Console:** When an alarm is generated, the VIP will contact the device connected to the Console Port in order to download data or report conditions.
- **Email/Text Message:** When an alarm is generated the VIP will send an email or text message to up to two user-defined addresses.

## **13.1. Alarm Actions for Alarm Filter Clues**

---

The VIP allows the definition of up to sixteen Alarm Clues for each of the two Alarm Filters. Each clue can be assigned its own individual Alarm Action. For example, when one Alarm Clue is triggered, the unit may perform a callout, when another Clue is triggered, the unit may perform an Output Contact operation.

In addition, each clue can be assigned separate callout numbers or pager numbers. When Alphanumeric Page is selected, up to three different Pager ID Numbers can be assigned to each clue. This allows the VIP to direct calls to a specific employee, depending on the nature of the alarm.

When Alarm Filters are configured, the VIP provides the option of defining default Alarm Actions that can be applied to all newly defined clues. In cases where an identical action will be applied to a series of clues, this allows you to enter action parameters for all clues without manually entering specifications for each clue. Note that these default parameters are not applied to the PBX Inactivity Alarms, 80% Full Alarm, or Output Contact Alarms.

## **13.2. Alarm Action Summary**

---

### **13.2.1. None (No Alarm Action)**

When this Alarm Action is selected, the VIP will not perform a special task when an alarm is generated. Note however, that call records will still be counted and flagged according to the clue matched. When data is released to the polling device, call records can still be sorted by the Alarm Clue matched.

### 13.2.2. Callout

If "Callout" is selected, the VIP will call a remote modem when an alarm is generated. After contacting the modem, the VIP can then send an Alarm Message and/or execute a user-defined command string. Typically, the Alarm Message describes the type of event that has occurred, and the Auto Execute Command string will usually report status or prompt the VIP to download data.

**Note:** In order to use the Callout action, Modem Port parameters must first be properly defined as described in Section 5.4.4.

When the Callout action is selected, the following items must be defined at the configuration menu for the specified alarm:

- **Phone Number:** Enter the number for your remote modem.
- **Message:** (Optional) Enter a message to describe the type of alarm event that occurred; for example "CHECK PBX".
- **Auto-Execute:** (Optional) Enable the Auto-execute function and then define the command string at the "Execute Commands" prompt. Auto Execute command strings are discussed further in Section 13.3.

### 13.2.3. Alphanumeric Page

When this Alarm Action is selected, the VIP will dial up to three alphanumeric pagers when an alarm is generated. After contacting each pager, the VIP can then send an Alarm Message that describes the nature of the alarm.

**Note:** In order to use the Alphanumeric Page action, Modem Port communications parameters must be properly defined as described in Section 5.4.4.

When Alphanumeric Page is selected, the following items must be defined at the configuration menu for the specified alarm:

- **Phone Number:** Enter the number for your pager service.
- **Pager ID Numbers:** Enter up to three Pager ID numbers. When an alarm is generated, the VIP will contact all defined Pager ID numbers, starting with Pager ID #1.
- **Message:** (Optional) Enter a message to describe the type of alarm event that occurred; for example "80% FULL".

### 13.2.4. Numeric Page

When "Numeric Page" is selected, the VIP will contact one numeric pager at a user defined number.

**Note:** Modem Port communications parameters must be properly defined as described in Section 5.4.4.

The following item must be defined at the configuration menu for the specified alarm:

- **Phone Number:** Enter the number for your numeric pager.

**Note:** For Numeric Paging, the Phone Number prompt can specify both the Pager phone number and a numeric "message". The phone number and message are entered in the following format:

**PHONENO@MESSAGENO#**

Where **PHONENO** is the pager phone number, and **MESSAGENO** is any number that will notify the user when an alarm occurs. For example, to dial 555-1212 and send the message "321", the phone number would be defined as "5551212@321#".

### 13.2.5. SNMP Trap

If this option is selected, the VIP will send an SNMP Trap to a user-defined IP address when an alarm is generated. The SNMP Trap can also include an alarm message.

**Note:** Network Port parameters must first be properly defined as described in Section 5.4.5. Make certain to specify IP Addresses for the SNMP Manager(s) that will receive the trap.

When the SNMP Trap action is selected, the following items must be defined at the configuration menu for the specified alarm:

- **SNMP Management:** Select one, both or none of the defined SNMP Managers. Note that IP addresses are defined via the Network Port configuration menu.
- **Message:** (Optional) Enter a message to describe the type of alarm event that occurred; for example "CHECK PBX".



---

### 13.2.6. Output Contact

If the "Output Contact" action is selected, the VIP can open or close the optional Output Contacts when an alarm is generated.

#### Notes:

- In order to use the Output Contact action, the Idle/Non-Alarm state for each contact should be defined as described in Section 12.
- The Output Contacts are an optional feature, and are not available on NLJ-VIP units.

When the Output Contact action is selected, the following item must be defined at the configuration menu for the specified alarm.

- **Output Contacts:** Specify the target Open/Closed/No Change action for each contact. When an alarm is generated, the Output Contacts will be opened or closed as specified.

### 13.2.7. Console

If this action is selected, the VIP will send a message via the Console Port when an alarm is generated. Typically, this message describes the type of alarm event that occurred. The VIP can also execute a user-defined command string to report status or download data.

**Note:** In order to use the Console action, Console Port communication parameters must first be defined as described in Section 5.4.3.

When the Console action is selected, the following items should be defined at the configuration menu for the specified alarm.

- **Message:** (Optional) Enter a message to describe the type of alarm event that occurred; for example "80% FULL".
- **Auto-Execute:** (Optional) Enable or disable the Auto-execute function and then define the command string at the "Execute Commands" prompt. Auto Execute command strings are discussed further in Section 13.3.

### 13.2.8. Email/Text Message

If this action is selected, the VIP will send an email or text message to up to two user-defined addresses when an alarm is generated. Typically, the email or text message includes a description of the type of alarm event that occurred. When this alarm action is used, the VIP can also execute a user-defined command string to report status or download data.

#### Notes:

- In order to use the Email Action, Network Port parameters must be properly defined as described in Section 5.4.5, and Email parameters must be configured as described in Section xx.
- The Address entered in the "Mail To:" field will determine whether an email or text message is sent when this type of action is performed. If a cell address (e.g., 5551234@cellservice.com) is entered in the "Mail To" field, a text message will be sent; if an email address is entered in the "Mail To" field, an email will be sent.

When the Email action is selected, the following item must be defined at the configuration menu for the specified alarm.

- **Message:** (Optional) Enter a message to describe the type of alarm event that occurred; for example, "CHECK PBX."
- **Email To:** Select both, none, or either of the two user-defined addresses that will receive messages generated by the alarm.

### 13.3. The Auto Execute Function

Both the Callout action and Console action allow the VIP to automatically execute a user-defined command string. This command string is usually employed to report system status or download data to the polling device.

The Auto Execute command consists of a string of ^Bxx Commands, which are listed in Section 19 of this User's Guide. Note that when the Auto-Execute string is defined, commands are entered without the ^B character, and each individual command is separated by a backslash followed by a forward slash character.

**Example 1:** To display system status and then download all stored alarm records, the Auto Execute string would be defined as follows:

```
\ /16\ /01 ,ALM
```

Where:

- 16**                    Indicates ^B16 (Display System Status).
- 01 ,ALM**            Indicates ^B01,ALM (Download all Alarm Records).

**Example 2:** To Display the Site ID message, display the reason for the Callout or Console action, and then download all alarm records that matched a clue named "TEST", the Auto Execute string would be defined as follows:

```
\ /03\ /18\ /01 , "TEST"
```

Where:

- 03**                    Indicates ^B03 (Send Site ID Message).
- 18**                    Indicates ^B18 (Display Reason for Callout or Console Action).
- 01 , "TEST"**        Indicates ^B01,"TEST" (Release Alarm Records for the Alarm Clue Named "TEST").



## 14. Scheduled Actions

---

Scheduled Actions are generally used to retrieve data from the VIP according to a user-defined time table. Typically, the VIP will contact your PC at the scheduled time and day, and then automatically download collected data.

In addition to its data collection function, the Scheduled Action feature can also be used to perform other tasks, such as Wellness Checks, Contact Switch operations, and etc. The VIP allows a great deal of flexibility in configuration of the Scheduled Action feature. The unit can perform any of the following actions according to the user-defined schedule:

- **Callout:** The VIP will contact a remote PC via modem, and execute a series of user-defined commands. Although these commands are usually employed to download data, they can also report memory conditions, alarm status, and etc.
- **Page:** The VIP will dial an alphanumeric pager and send a user-defined message. This allows the VIP to perform a wellness check, or inform system managers that the unit is operating properly.
- **SNMP Trap:** The VIP will send an SNMP Trap to a network manager. This option can also be used to perform a wellness check, or notify personnel that it is time to check the unit.
- **Console Port:** The VIP will contact the device connected to its Console Port in order to download data or report status.
- **Email/Text Message:** The VIP will send a text message or email to either or both user defined addresses.
- **Output Contact:** (Optional - Not Available on NLJ-VIP units) The NetLink-VIP will open or close the optional Output Contact switches.

Each of the two available schedules allow up to seven scheduled actions per week. This provides a total of fourteen events per week. For more information on these actions, please refer to Section 13.

```

SCHEDULED ACTION 1:

SCHEDULE                                ACTION PARAMETERS
1. Schdl Action:      Off                11. Action:      None
2. Sunday:           Off                12. Phone #:    (undefined)
3. Monday:           Off                (Cont.):
4. Tuesday:          Off                13. Pager ID 1: (undefined)
5. Wednesday:        Off                14. Pager ID 2: (undefined)
6. Thursday:         Off                15. Pager ID 3: (undefined)
7. Friday:           Off                16. SNMP Mgmt:  Manager #1
8. Saturday:         Off                17. Output Contacts
                                1/2/3/4:      -/-/-/
09. Add Exclusion
10. Delete Exclusion

EXCLUSION (MM/DD)
--/--  --/--  --/--  --/--
--/--  --/--  --/--  --/--
--/--  --/--  --/--  --/--
--/--  --/--  --/--  --/--
--/--  --/--  --/--  --/--
--/--  --/--  --/--  --/--
09. Add Exclusion
10. Delete Exclusion

Enter selection,
Press <ESC> to return to previous menu ...

11. Action:      None
12. Phone #:    (undefined)
(Cont.):
13. Pager ID 1: (undefined)
14. Pager ID 2: (undefined)
15. Pager ID 3: (undefined)
16. SNMP Mgmt:  Manager #1
17. Output Contacts
1/2/3/4:      -/-/-/
18. Message:    (undefined)
(Cont.):
(Cont.):
19. Auto Execute: Off
20. Execute Cmds: (undefined)
(Cont.):
(Cont.):
(Cont.):
21. Email to:   Email #1
    
```

Figure 14.1: Scheduled Action Configuration Menu (Schedule 1 Shown)

To access the Scheduled Action configuration menus from the Main Menu, type **24** and press **[Enter]**, a selection menu will be displayed. Next, type **1** for Schedule 1, or **2** for Schedule 2, and press **[Enter]**. Both configuration menus include the following:

**Schedule:**

- 1. **Scheduled Action:** Enables/disables the Scheduled Action function. Note that in addition to enabling the schedule, the user must also define the schedule and specify the action that will be performed according to schedule.
- 2-8. **Daily Schedules:** Defines the time that the action will be performed on each day of the week. Time values are entered in 24-hour (Military) format.

**Exclusions:**

- 9. **Add Exclusion:** Defines dates (such as holidays) when the Scheduled Action will not be performed. As each exclusion is defined, it will be added to the display above item 9.
- 10. **Delete Exclusion:** Deletes a date from the exclusion list.

**Action Parameters:**

11. **Action:** Defines the type of event that will occur according to the schedule. The user may select None, Callout, Alphanumeric Page, Numeric Page, SNMP Trap, Output Contact, Console or Email/Text Message.
12. **Phone Number:** Defines the phone number that will be dialed for a scheduled Callout or Page. This is the number for your remote modem or pager service.

**Note:** For Numeric Paging only, this prompt can specify both a pager phone number and a numeric "message". In this case, the phone number is entered using the following format:

**PHONENO@MESSAGENO#**

Where **PHONENO** is the pager number, and **MESSAGENO** is any number which will notify the user that a scheduled page has occurred. For example, to dial 555-1212 and send the message "999", the phone number would be defined as "**5551212@999#**".

13. **Pager ID 1:** The first Pager ID Number used when a scheduled alphanumeric page is performed. The VIP will dial up to three pagers for each schedule.
14. **Pager ID 2:** The second Pager ID for this schedule.
15. **Pager ID 3:** The third Pager ID for this schedule.
16. **SNMP Management:** The SNMP Manager(s) that will receive SNMP Traps generated by this schedule. This prompt can select Manager 1, Manager 2, or both. Note that IP addresses for each SNMP Manager are defined via the Network Port Configuration menu.
17. **Output Contacts:** (Optional - Not Available on NLJ-VIP units)  
When an Output Contact action is scheduled, this prompt selects the Open/Close operation for the optional Output Contacts. An "O" indicates that the corresponding contact will be opened as scheduled, a "C" indicates the contact will be closed, a dash (-) indicates that the status of the contact will not be changed.

18. **Message:** Defines the message that will be sent for a Scheduled Callout, Alphanumeric Page, SNMP Trap, Console Action or Email/Text Message.
19. **Auto Execute:** When this item is enabled, the VIP can be scheduled to automatically execute the command string defined under item 20.
20. **Execute Commands:** The Auto-Execute command string. This command string consists of a series of VIP ^Bxx commands, with each command separated by a backslash character and a forward slash character (e.g., `\04\01`). ^Bxx commands are described in Section 19. For more information on Auto-Execute command strings, please refer to Section 13.3.

When the Schedule Action feature is used to download data or send a wellness message, the Auto Execute string must be defined in order to specify the exact task to be performed. For example, to instruct the VIP to automatically send the Site ID message and then send all alarm records, the Auto Execute string would be defined as "`\03\01,ALM`".

**Notes:**

- When the Auto-Execute string is defined, commands are entered without the ^B character, and each individual command is separated by a slash character.
  - In order for the Auto Execute feature to function, item 19 must be enabled, the command string must be defined, and item 11 (Action) must be set to perform a Callout or Console action.
21. **Email To:** The email address(es) that will receive email and text messages generated by this schedule when the Email/Text Message action is selected. This item can select either or both of the two user-defined email addresses, which are defined via the "Send Email" configuration menu, as described in Section 5.4.5.1.



## 15. Saving VIP Parameters

---

This chapter discusses the VIP functions related to saving and restoring user-defined parameters. Two different functions are discussed; saving parameters to flash memory, and saving parameters to an ASCII file at your polling device.

### 15.1. Saving Parameters to Flash Memory

---

During configuration, newly defined parameters are stored in the VIP's temporary memory. Although these new parameters will determine the unit's current setup, parameters stored in temporary memory may be lost if there is a power interruption. To ensure that setup parameters are retained, it is recommended to save parameters to flash memory.

When parameters are changed, the unit will display a prompt to notify the user that newly defined parameters have not been saved. Main Menu item 7 is used to save parameters from temporary memory to flash memory.

If the user exits from command mode without first saving new parameters, the VIP will display a menu that offers the following options:

- **Save and Exit:** The VIP will save all configuration parameters to flash memory and then exit.
- **Exit Without Saving:** The VIP will exit from command mode without saving parameters to flash memory. Newly defined parameters will still be stored in temporary memory, but may be lost if there is an interruption of power to the unit.
- **Restore Previous Parameters:** Newly defined parameters will be discarded and the VIP will be reconfigured with the parameters that were previously saved to flash memory.

**Note:** Command ^B74 can also be used to save user-defined VIP parameters to flash memory. As described in Section 19, Command ^B74 offers the option save parameters to flash memory or restore parameters from flash memory.

## 15.2. Saving and Restoring Parameters from an ASCII File

---

After the VIP has been configured, parameters can be saved to an ASCII text file using the File Mode in ProComm or another communications program. Later, if the configuration is altered or deleted, saved parameters can be uploaded to quickly reconfigure the unit without the need to manually enter each parameter.

When parameters are downloaded to an ASCII File, the VIP will send the parameters that are displayed by the status screens. The VIP offers two different methods for saving parameters to an ASCII file; the Menu Driven Method and the Command Driven Method.

### 15.2.1. Saving Parameters to an ASCII File (Menu Driven Method)

This method uses the VIP's menu system to initiate the download.

1. Set your communications program (e.g. Tera Term, Hyperterminal, etc.) to receive an ASCII text file and specify a file name for the saved parameters.
  - a) When using ProComm, press **[Page Down]** to activate the "Receive Parameters" mode. Select "Raw ASCII". Type in a filename for the saved parameters and press **[Enter]**.
2. Access the VIP Command Mode as described in Section 19.1.
3. Download the VIP's parameter settings to an ASCII file.
  - a) From the VIP Main Menu, type **3** and press **[Enter]**, the System Functions menu will appear as shown in Figure 15.1.
  - b) When the System Functions menu appears, type **6** and press **[Enter]** to begin the download. The VIP will send parameters to the polling device, where they will be saved to the ASCII filename selected in Step 1.
  - c) If you are using ProComm, press **[Esc]** to exit the Receive Parameters Mode.

```
SYSTEM FUNCTIONS:

1. Security Level
2. "Passthrough" Mode
3. "Monitor" Mode
4. Clear Alarm Condition
5. Clear Alarm Clue Counters
6. Download Parameters
7. Audit Trail Functions
8. Upload Firmware

Enter selection,
Press <ESC> to return to previous menu ...
```

Figure 15.1: System Functions Menu

### 15.2.2. Saving Parameters to an ASCII File (Command Driven Method)

VIP parameters can also be saved to an ASCII file using Command ^B99. Command ^B99 performs the same task as the System Function Menu's "Download Parameters" function.

To save parameters to an ASCII file using the Command Driven Method, proceed as follows:

1. Set your communications program to receive an ASCII text file and specify a file name for the saved parameters.
  - a) When using ProComm, press **[Page Down]** to activate the "Receive Parameters" mode. Select "Raw ASCII". Type in a filename for the saved parameters and press **[Enter]**.
2. Access command mode as described in Section 19.1.
  - a) If the password function is enabled, enter the valid Supervisor Level password. The VIP must be operating in Supervisor Mode in order for the download command to function.
  - b) Note that this procedure can be performed from anywhere in the VIP menu system.

3. Before invoking Command ^B99, make certain the command echo is disabled at the command port which will drive the download. If the command echo is enabled when Command ^B99 is invoked, the ^B99 command will be included in the file with the saved parameters. This will cause problems when the file is uploaded to the VIP unit,
  - a) The Command Echo is enabled/disabled using the Port Configuration Menus as described in Section 5.4.
  - b) If desired, the command echo can also be temporarily suppressed by entering the ^A character in place of the ^B character (e.g. ^A99). Note that this method can also be applied to other ^Bxx commands to temporarily suppress the command echo.
4. Invoke command ^B99. From any VIP command menu, type ^B99 (or ^A99) and then press **[Enter]**. VIP parameters will be sent to the polling device, where they will be saved to the ASCII filename selected in Step 1.

---

### **15.3. Configuring the VIP with Saved Parameters**

---

Once parameters have been saved to an ASCII file, the file can then be uploaded to the VIP to reconfigure the unit without manually defining each parameter.

The ASCII file with the saved parameters can also be uploaded to other VIP units. This allows rapid set-up when a number of units will be configured with the same parameters.

1. Access command mode as described in Section 19.1.
  - a) If the password function is enabled, enter the valid Supervisor Level password. The VIP must be operating in Supervisor Mode in order for this procedure to function.
  - b) Note that this procedure can be performed from anywhere in the VIP menu system.
2. Use your communication program's upload function to transfer the file that contains the saved parameters to the VIP unit via modem or the Console Port.
  - a) Select ASCII File Format.
  - b) Specify the filename and directory location for the file with the saved parameters. Note that it is very important to enter the correct filename and location. Sending an incorrect file to the VIP unit will cause unpredictable results.
3. If an Error message is received at any time during the parameter upload, repeat steps 1 and 2 above to resend the entire file.

#### **Notes:**

- If the file with the saved parameters is sent to the VIP via the Computer Port (from a local PC), changes will take effect immediately.
- If the parameter file is sent to the VIP via the Modem Port, Modem Communication Parameters will not take effect until after you exit from Command Mode. The Port Status Screen will not show the new Modem Port parameters until you have exited and re-entered Command Mode.



## **16. Buffer Functions (Polling)**

---

The procedures in this section are used to retrieve data that has been collected from the PBX. The VIP offers four different polling methods:

1. **Menu Driven:** The VIP is contacted via modem or Console Port, and the Buffer Functions Menu is used to release data.
2. **Command Driven:** The VIP is contacted via modem or Console Port, and ^Bxx commands are entered at the command prompt to release data.
3. **FTP Push:** The VIP automatically downloads records via TCP/IP connection to your FTP server.
4. **FTP Server:** an FTP client program is used to retrieve stored data from the VIP unit on demand. In this case, the VIP functions exactly like a standard FTP server.

### **16.1. Memory Partitions and Shared Data**

---

After data is collected from the PBX, it is stored in the VIP's memory. Stored data can be retrieved via the Console Port, Modem Port, or Network Port. In order to prevent conflicts when two ports attempt to access the same data, partitions are set to temporarily grant "ownership" of a specific type of data to a specific port. For example, the Console Port may own all data received via PBX Port B, or the Modem Port may own all records that matched Alarm Filter 1.

When a partition is set for a specific command port, other command ports will not be able to access the partitioned data. For example, if the Console Port partition is set to include data received via PBX Port A, then the Modem Port will not be able to access this data until the partition is released.

These partitions also simplify the process of clearing data after it has been read. After downloading data from your command port partition, command ^B25 or the Item 5 in the Buffer Functions menu can be used to clear the partition. Note that records that are received after the partition is set will not be erased. Once a partition is set, it will remain in effect until the partition owner exits from command mode, or invokes one of the partition release commands.

		Source Port			
		PBX Port A (PA)	PBX Port B (PB)	AUX Port (PX)	PBX IP Port (PI)
Data Type	Standard, Non-Alarm (D)	(PA) (D)	(PB) (D)	(PX) (D)	(PI) (D)
	Alarm Filter 1 (A1)	(PA) (A1)	(PB) (A1)	(PX) (A1)	(PI) (A1)
	Alarm Filter 2 (A2)	(PA) (A2)	(PB) (A2)	(PX) (A2)	(PI) (A2)

Figure 16.1: Data Partitions and Files (NetLink-VIP)

		Source Port	
		PBX Port A (PA)	PBX IP Port (PI)
Data Type	Standard, Non-Alarm (D)	(PA) (D)	(PI) (D)
	Alarm Filter 1 (A1)	(PA) (A1)	(PI) (A1)
	Alarm Filter 2 (A2)	(PA) (A2)	(PI) (A2)

Figure 16.2: Data Partitions and Files (NLJ-VIP)

### 16.1.1. Partitions and Files

When data is received from the PBX, the VIP sorts each record into one of several possible "files." Records are sorted according to Data Type and Source Port. There are three Data Types; Standard Data (Non-Alarm Records), Records that match Alarm Filter 1, and Records that match Alarm Filter 2. The NetLink-VIP offers four possible source ports: PBX Port A, PBX Port B, the AUX Port and the PBX IP Port. The NLJ-VIP offers two possible source ports: PBX Port A and the PBX IP Port.

For NetLink-VIP models, this means that there are twelve possible files, because the NetLink-VIP provides three data types and four source ports as shown in Figure 16.1. For NLJ-VIP models, this means that there are six possible files, because the NLJ-VIP provides three data types and two source ports as shown in Figure 16.2.



As shown in Figures 16.1 and 16.2, each file contains a specific data type received from a specific port. When a command port sets a partition, that port is granted ownership of one or more of these files. The File List screen (Status Displays, Item 2) can be used to determine which files are linked to each command port.

Note that these files are always "open"; new data is continually added to each file. When a partition is set, all records received up to that point will be available for reading or erasure. However, new records received after the partition is set will not be available until the partition is reset.

Note also that the "Store Alarm Data" option can be used to override the default storage location for alarm records. Using this option, alarm records for a selected port can be stored in the Alarm Files, in the Standard File (Non-Alarm), or in both the Alarm File and Non-Alarm File. This allows Alarm Records to be used for call accounting purposes only, alarm tracking only, or for both. The "Store Alarm Data" option is located in the configuration menus for PBX Port A, PBX Port B, and the AUX Port.

### 16.1.2. Setting the Partition

The following events will cause the VIP to set a data partition:

1. **Menu-Driven Read Session:** When the Buffer Functions menu is used to release data, a partition will be set for the port that initiated the read session. This partition will include all data selected by the Read Session Parameters menu. For more information, please refer to Section 16.2.
2. **Command Driven Read Session:** When command ^B01 is invoked, a partition will be set for the port that initiated the command. This partition will include all data specified by the ^B01 command arguments. For more information, please refer to Section 16.3.
3. **Set Partition Function:** When the Set Partition function (Buffer Functions Menu) is performed, a partition will be set for the port that activated the function. This partition will include all data currently specified by the Read Session Parameters menu. If the Data Type and Source port have not been selected, the partition will include all data by default. For more information, please refer to Section 16.2.
4. **Command ^B00:** When command ^B00 (Set Partition) is invoked with the proper arguments, a partition will be set for the port that invoked the command. This partition will include all data specified by the ^B00 command arguments. For more information, please refer to Section 16.3.1.
5. **FTP Push:** When an FTP Push operation is in progress, a partition will be set which will include all files that were requested via the FTP Push Configuration menu. For more information, please refer to Section 16.4.
6. **FTP Server:** When the FTP Server function is being used to retrieve files, a partition will be set which will include all files requested by the FTP client (e.g. WS FTP.) For more information, please refer to Section 16.5.

#### Notes:

- Partitions remain in effect until the partition owner exits command mode, invokes one of the partition release commands, or sets a new partition.
- Other ports are not allowed to access partitioned data until the partition is released.

### **16.1.3. Releasing the Partition**

Any of the following events will release the partition:

1. **Exit Command Mode:** When the Console Port, Modem Port, or Network Port exits from command mode, the VIP will release the partition for that port.
2. **Release Partition Function:** When this function (Buffer Functions Menu) is performed, the VIP will release the partition for the port that invoked the command. For more information, please refer to Section 16.2.
3. **Release Remote Partition:** (Supervisor Mode Only) This function can be used to release a partition that was established by another port. The Release Remote Partition function is available via the Buffer Functions menu, or by invoking command `^B76` with the proper arguments. For more information, please refer to the Command Reference Guide in Section 19.
4. **Command `^B00,R`:** When command `^B00` is invoked with the "R" argument (`^B00 ,R`), the VIP will release the partition for the port that invoked the command. For more information, please refer to Section 16.3.1.
5. **At the End of an FTP Push Session:** When the FTP Push feature finishes sending the requested data, the partition that was set for the FTP Push feature will be released. For more information, please refer to Section 16.4.
6. **FTP Server Function:** The partition that is set for the FTP Server function will be released when any of the following events occur:
  - a) When the FTP client disconnects, the partition for the selected file will be released.
  - b) After a file has been downloaded to the FTP client, the partition will be released if the file is deleted from the VIP's buffer memory, either by the Auto Delete function, or by the FTP client's delete function.
  - c) When the FTP client is used to select a different file, the partition for a previously selected file (if any) will be released.

## 16.2. Menu Driven Data Release

---

The VIP offers four different methods for retrieving buffered data; menu driven data release, command driven data release, FTP Push and FTP Server data transfer. During menu driven data release, the Buffer Functions menu controls and configures the data release process. The menu driven procedure consists of the following three steps:

**Note:** Prior to reading data, the user must configure output options for the port that will drive the data release, as described in Section 5.4.

1. **Set Read Session Parameters:** Use item 1 in the Buffer Functions menu to select desired data types, source port, and other options as described in Section 16.2.2.
2. **Set Partition:** Use item 2 in the Buffer Functions menu to set the partition for your command port as described in Section 16.2.1.
3. **Begin Data Release:** Use item 4 in the Buffer Functions menu to begin data release as described in Section 16.2.1.

### 16.2.1. The Buffer Functions Menu

After configuring the command port, go to the VIP Main Menu, and type **2 [Enter]** to display the Buffer Functions Menu (Figure 16.3.) The Buffer Functions menu offers the following options:

1. **Set Read Session Parameters:** Selects Read Session parameters, including the Source Port, Data Type, Start Record, and Record Count. For more information on Read Session Parameters, please refer to Section 16.2.2.
2. **Set Partition:** Sets the partition for the user's port according to currently selected Read Session Parameters. If Read Session Parameters have not been redefined, the partition for this port will include all records by default.
3. **Release Partition:** Releases the port's partition, allowing other ports to access the formerly partitioned data.
4. **Enter "Read" Session:** When this item is selected, the VIP will display a submenu before beginning data release. The following options are available:
  - a) **Start Data Output:** To begin, press **[Enter]**.
  - b) **Next Group (^B02):** This is used when releasing groups of records as described in Section 16.2.2. For example, if Record Count is set at 10, the VIP will release a group of ten records and then pause. To release the next group, invoke command **^B02**.

```

BUFFER FUNCTIONS:

1. "Read" Session Parameters
2. Set Partition
3. Release Partition
4. Enter "Read" Session
5. Erase Partition Data
6. Erase All Data
7. Erase All Data & Clear Alarm Clue Counters
8. Release Remote Partition

Enter selection,
Press <ESC> to return to previous menu ...

```

Figure 16.3: Buffer Functions Menu

- c) **Re-read Last Data Record (^B06):** This option is used when releasing groups of records (Record Count) as described in Section 16.2.2. For example, if Record Count is set at 5, the VIP will release a group of five records and then pause. To resend this group, invoke command ^B06.
- d) **Exit (^B30):** To exit from data release mode and return to the Buffer Functions menu, invoke command ^B30.

#### Notes:

- When all specified records have been released, the "End Data" message is sent. If "Hold End Data" is enabled, a ^B02 command is required in order to release the End Data message and complete the data release procedure.
  - If "Data On ^B01" is disabled, a ^B02 command must be sent in order to begin the data release.
5. **Erase Partition Data:** Erases all data in the current memory partition. The VIP will display a "Sure ?" prompt; if confirmation is given, all data in the partition will then be erased. Note that this function will not erase records received *after* the partition was set.
  6. **Erase All Data:** Erases all stored records, including records in partitions owned by other ports. Note that the VIP will not erase records that are currently being read by another port.
  7. **Erase All Data & Clear Alarm Counters:** Erases all stored records (including records in partitions owned by other ports), and resets all Alarm Clue Counters to zero.
 

**Note:** Erased call records *cannot* be recovered.
  8. **Release Remote Partition:** (Supervisor Mode Only) Releases a partition established by another port. Allows access to data assigned to another port. Note that a remote partition *cannot* be released while another port is reading data from that partition.

```
"READ" SESSION PARAMETERS:
1. Source Port:      All
2. Data Type:       All
3. Start Record:    1
4. Record Count:    All

Enter selection,
Press <ESC> to return to previous menu ...
```

Figure 16.4: Set Read Session Parameters Menu

### 16.2.2. Read Session Parameters

The Set Read Session Parameters submenu (Figure 16.4) is used to select options that are applied when data is released.

**Note:** If the port partition has not been set, values selected for the Source Port and Data Type options will determine the partition location. When a Read Session is initiated, or the Set Partition option is selected, the partition is set according to the Source Port and Data Type options.

1. **Source Port:** The VIP can release all data, or only data received via a selected port. You may select PBX Port A, PBX Port B, the AUX Port, the PBX IP Port, all four ports, or any combination. (Note that PBX Port B and the AUX Port are not available on NLJ-VIP units.)
2. **Data Type:** Determines which type of data will be released. The following data types may be selected:
  1. **All:** Releases all data from the buffer, including both alarm data and non- alarm data.
  2. **Standard (Non-Alarm):** Release records that did not match an Alarm Clue.
  3. **Alarm 1 (All):** Release all data that matched any Alarm Clue defined for Alarm Filter 1.
  4. **Alarm 1 (By Clue):** Release records that matched a specific Alarm Clue for Alarm Filter 1.
  5. **Alarm 2 (All):** Release all data that matched any Alarm Clue defined for Alarm Filter 2.
  6. **Alarm 2 (By Clue):** Release records that matched a specific Alarm Clue for Alarm Filter 2.
  7. **All Alarms:** Release records that matched Alarm Filter 1 and records that matched Alarm Filter 2.

3. **Start Record:** Determines the starting point for data release. For example, if Start Record is set at 153, the 153rd record in memory will be the first record released. Note that if a negative value is entered, the VIP will determine the starting point by counting backwards from the end of the records in the current partition. For example, if the Start Record is set at -10, the VIP will release the last ten records in the current partition.
4. **Record Count:** Determines how many records are released in each group. For example, if Record Count is set at 20, the VIP will release 20 records and then pause. Invoke command ^B02 to release the next group.

### **16.3. Command Driven Data Release**

---

Data can also be released by invoking Command ^B01. The ^B01 command line can include optional arguments which are used to release specific types of data. These arguments are similar to the options offered under the Set Read Session Parameters menu. The command driven procedure consists of the following steps:

**Note:** Prior to reading data, the user must select output options (Output Mode, Data on ^B01, etc.) for the port that will drive the data release, as described in Section 5.4.

1. **Release Data Partition:** Use command ^B00 to release the current partition for your port. At the command prompt type ^B00, R and then press [Enter]. Other ^B00 command options are listed in Section 16.3.1.

#### **Notes:**

- The Release Remote Partition function (Supervisor Mode Only) can also be used to access data that has been assigned to another port. Please refer to command ^B76 in the Command Reference Guide (Section 19.)
  - A remote partition *cannot* be released while another port is reading data from that partition.
2. **Begin Data Release:** Invoke command ^B01 with the appropriate arguments to release the desired data. Section 16.3.2 describes the various arguments for command ^B01.

### 16.3.1. Command ^B00 (Set/Release Partition)

Command ^B00 can be used to set or release the partition prior to beginning command driven data release.

#### Notes:

- If the ^B00 command line does not include an argument, the partition will be set to include all data by default.
- Although the ^B00 command line can include both the Data Type and Source Port arguments, the Release partition argument (R) cannot be combined with another argument.

Command ^B00 uses the following format:

**^B00 [ , type ] [ , source ] or ^B00 ,R**

Where:

- , type**    **Data Type:** Offers the following options:
- ,D** or **,STD**    (Standard Data) Records that did not match an Alarm Filter Clue.
  - ,A1** or **A**    Records that matched a Clue for Alarm Filter 1.
  - ,A2**    Records that matched a Clue for Alarm Filter 2.
  - ,ALM**    Records that matched Alarm Filter 1 and records that matched Alarm Filter 2.
  - (Not Specified)    Include all data types.
- , source**    **Source Port:** Offers the following options:
- ,PA**    Records received via PBX Port A.
  - ,PB**    Records received via PBX Port B.
  - ,PX**    Records received via AUX Port.
  - ,PI**    Records received via the PBX IP Port.
  - (Not Specified)    Records received from any of the three input ports.

#### Release Partition:

- ,R**    Release the current data partition. Cannot be combined with other ^B00 arguments.

#### Examples:

- ^B00 ,D**    Set partition to include all records that did not match an Alarm Clue, regardless of the Input Port that received them.
- ^B00 ,A1 ,PX**    Set partition to include records that matched Alarm Filter 1, and were received via the AUX Port.



### 16.3.2. The ^B01 Command Line

If the ^B01 command line does not include optional arguments, and no partitions have been set, command ^B01 will release all data by default.

**Note:** If the partition for your port has not been set, the ^B01 command arguments will set the partition location.

Command ^B01 offers the following options:

```
^B01 [ , type ] [ , source ] [ @n ] [ , n ] [Enter]
```

Where:

- , type Data Type:** The following options are available:
- ,A1 or ,A** Records that matched a Clue from Alarm Filter 1.
  - ,A2** Records that matched a Clue from Alarm Filter 2.
  - ,ALM** Records that matched Alarm Filter 1 and records that matched Alarm Filter 2.
  - ,STD or ,D** Standard (Non-Alarm) Records.
  - , "clue"** **Clue Name:** Release Alarm Records for clue. The Clue Name must be enclosed in quotation marks.
- , source Source Port:** The following options are available:
- ,PA** Records received via PBX Port A.
  - ,PB** Records received via PBX Port B.
  - ,PX** Records received via the AUX Port.
  - ,PI** Records received via the PBX IP Port.
- @n Start Record (Offset):** Releases records starting with the "nth" record. For example, if ^B01@234 is entered, data release will start with the 234th record. If a negative value is entered, the VIP will determine the starting point by counting backwards from the end of the records in the current partition.
- , n Record Count:** Releases records in groups of "n". For example, if ^B01 , 20 is entered, the VIP will release groups of 20 records, and then pause until ^B02 is sent.

### Notes:

- If both Alarm Filters include identical clue names, the data release command must specify the desired Filter. For example, if Alarm Filters 1 and 2 both include a clue named **TEST**, to retrieve alarm data from filter 1, the command would be invoked as **^B01 ,A1 , "TEST"**.
- Square brackets are *not* included in the command line. They are shown here to indicate optional command arguments.
- Each option is preceded by a comma, with the exception of the Start Record option (**@n.**) Do not enter a comma before the "@" character.
- When all specified records have been released, the "End Data" message is sent. If "Hold End Data" is enabled, a **^B02** command is required in order to release the End Data message, and complete the data release operation.
- If "Data On ^B01" is disabled, a **^B02** command must be sent in order to begin data release.
- When Command **^B01,n** is invoked to release data in groups of n records, type **^B02 [Enter]** to release the next group of records, or type **^B06 [Enter]** to resend the previous group.

### 16.3.3. Command ^B01 Examples

As shown in the examples below, arguments can be combined in a single command line to further define the data release format.

#### Examples:

- **^B01 , PA , 10** would release only data received via PBX Port A. Data would be released in groups of ten records. Note that a **^B02** would be required in order to release any subsequent groups of data.
- **^B01 , PX@10** would release only data received via the Auxiliary Port, beginning with the tenth record.
- **^B01 , PB@65 , 12** would release only data received via PBX Port B. Data would be released in groups of twelve records, beginning with the 65th record. Note that a **^B02** would be required in order to release any subsequent groups of data.

### **16.3.4. Other Commands Used During Data Release**

The following commands are often used during command driven data release. For a complete listing of all available commands, please refer to Section 19.

1. **Site ID:** To send the Site ID, type **^B03 [Enter]**.
2. **Display Current Alarm Record:** Type **^B08 [Enter]**.
3. **Remaining Memory Space:** To send a message that lists the VIP's remaining memory, type **^B21 [Enter]**.
4. **Set-Up Switches:** To send a message that lists the current status of the Set- Up Switches, type **^B24 [Enter]**.
5. **Number of Stored Records:** To list the number of records in the current partition, type **^B20** and press **[Enter]**.
6. **Display Separator Line:** To send a line of dashes, which can be used to separate downloaded data, type **^B26** and press **[Enter]**.
7. **Continuous Binary Block Read:** To initiate a continuous binary block read, invoke command **^B07**. Blocks are sent continuously, without acknowledgment, and cannot be retransmitted during the read session. Data is sent in binary block format, regardless of the current output setting. All data type and source port arguments are available. For more information, please see Section 19.

**Note:** Command **^B07** (Continuous Binary Block Read) should not be used while Auto Delete is enabled. If **^B07** is invoked while Auto Delete is enabled, the unit will erase data without waiting for reception to be acknowledged.

8. **Binary Information Block:** To send a status information block in binary format, type **^B73** and press **[Enter]**. The information block includes the Site ID, time and date, Reason for Action, Partition Record Count, and Percent Full. Information is sent in binary block format, regardless of the current output mode setting.

```
FTP PUSH CONFIGURATION:

FTP SERVER PARAMETERS                                ACTION PARAMETERS
1.  Server Address: (undefined)                      11. Read Session
2.  UserName:      (undefined)                       12. Push Action:      Off
3.  Password:      (undefined)                       13. Periodic Push:   1440 Mins
4.  Account:       (undefined)                       14. Xmit Attempts:   5
5.  Directory:     (undefined)                       15. Xmit Delay:      5 Mins
   (Cont.):         (undefined)                       16. Auto Delete:     Off
   (Cont.):         (undefined)                       17. Start Time:      (undefined)
6.  File Name:     (undefined)
7.  File Mode:     Append
8.  File Ext Inc:  Off

MISCELLANEOUS
21. Force FTP Push
22. Test FTP Push
23. Stop FTP Push

Enter selection,
Press <ESC> to return to previous menu ...
```

Figure 16.5: FTP Push Configuration Menu

## 16.4. Retrieving Data Using FTP Push

FTP Push capability allows the VIP to automatically download stored call records via network to your FTP server. Downloads can be performed on demand, according to a user-defined schedule, or according to a user-specified start time.

In order to use this feature, your installation must include the following:

- A network connection to the VIP unit. Note that the network must be running TCP/IP in order for FTP Push to function.
- A network connected FTP server on subnet, or the gateway address must allow packets from the VIP to be routed to your FTP server.

To configure the FTP Push function, access the VIP command mode as described in Section 19.1. When the Main Menu appears, type **27** and press **[Enter]** to display the FTP Push Configuration menu as shown in Figure 16.5.

The FTP Push Configuration menu is used to select parameters that will be employed when the VIP transfers stored data to your FTP server. To define FTP Push parameters, key in the number for the desired item, press **[Enter]**, then follow the instructions in the submenu that follows. The FTP Push Configuration menu includes the following items:

### FTP Server Parameters:

1. **Server Address:** The IP address of your FTP server (the address that will receive the transferred files.) (**Up to 15 characters, default = undefined.**)

2. **User Name:** The name that the VIP will use when accessing the FTP server. (**Up to 16 characters, default = undefined.**)
3. **Password:** The password that the VIP will use when accessing the FTP server. (**Up to 16 characters, default = undefined.**)
4. **Account:** The account name that will be used to access the FTP server. (**Up to 16 characters, default = undefined.**)
5. **Directory:** The FTP Server directory that will receive files sent from the VIP. (**Up to 48 characters, default = undefined.**)

**Note:** If several different VIP units will be transferring data to the same FTP server, a unique directory / file name should be assigned to each unit. This will prevent data from the various units from overwriting each other.

6. **File Name:** The first four characters of the file name that the FTP Push feature will assign to each "chunk" of data transferred from this unit. The complete file name will include these four characters, three characters which identify the source port, and one character which identifies the data type. If desired, the VIP can also append a sequentially numbered extension to each file name. For more information, please refer to Section 16.4.1. (**Up to four characters, default = undefined.**)

**Note:** If several different units will be transferring data to the same FTP server, a unique file name / directory should be assigned to each unit. This will prevent the VIP units from overwriting each other's data.

7. **File Mode:** If "Append" is selected, each data transfer will be added to the target file on the FTP server. If "Replace" is selected, each data transfer will overwrite the target file. If the target file does not exist, then both Append and Replace will create a new file. (**Default = Append.**)
8. **File Extension Increment:** Enables / disables automatic sequential numbering of file names created by the FTP Push feature. When enabled, the VIP will append a sequentially numbered three digit file name extension (000 to 999), which will be incremented for each new file created by a successful data transfer. When disabled, the extension will not be incremented. (**Default = Off.**)

**Action Parameters:**

11. **Read Session:** Specifies the type(s) of file that will be sent to the FTP server. When PBX data is collected, the VIP sorts records according to the port where the data was received and the Alarm Filter matched. The "Read Session" item allows you to select data based on these criteria, and determine the starting point by record number. For more information, please refer to Section 16.1. The "Read Session Parameters" submenu includes the following items:

- a) **Source Port:** Option 1 allows you to select records based on the VIP port where they were received. When selected, the VIP will display an additional submenu, which is used to toggle each port On or Off. This item can be used to select one, two or all of the available source ports. **(Default = All.)**

**Example:** If PBX Port A and the AUX Port are both toggled "On", the FTP Push session will only send data received at PBX Port A or the AUX Port; data received via PBX Port B would not be sent.

- b) **Data Type:** Allows you to choose records based on the Data Type. When selected, the VIP will display a submenu, which is used to choose one of the following file types. Note that only one file type can be selected at a time. **(Default = All.)**

1. **All:** Send all records, both Alarm and Non-Alarm.
2. **Standard (Non-Alarm):** Send only records that did not match a clue for Alarm Filter 1 or Alarm Filter 2.
3. **Alarm Filter 1 (All):** Send only records that matched any clue defined for Alarm Filter 1.
4. **Alarm Filter 1 (By Clue):** Send only records that matched a specific clue defined for Alarm Filter 1.
5. **Alarm Filter 2 (All):** Send only records that matched any clue defined for Alarm Filter 2.
6. **Alarm Filter 2 (By Clue):** Send only records that matched a specific clue defined for Alarm Filter 2.
7. **All Alarms:** Send all records that matched either Alarm Filter 1 or Alarm Filter 2.

**Notes:**

- When the "By Clue" options are selected, the VIP will prompt you to enter the clue name. If an invalid clue name is entered, the prompt will be redisplayed.
  - When Data Type and Source Port are assigned, then the FTP Push function will own this partition while the data transfer is in progress. Other users will not be able to read data from this partition until the FTP Push is complete and the FTP connection is terminated. For example, if FTP Push is set to select Non-Alarm data (Data Type) received via PBX Port B (Source Port), then the Console Port will not be able to read Non-Alarm Data received via PBX Port B until FTP Push is complete and the partition is released.
- c) **Start Record:** The starting point for data release. Note that this value can be either positive or negative (**Default = 1.**)
- **Positive Numbers:** If a positive number is entered, the unit will count forward from the beginning of the selected group (Source Port / Data Type.) For example, if this value is "15", the VIP will begin with the 15th record in the group.
  - **Negative Numbers:** If a negative number is entered, the VIP will count backwards from the end of the records in the selected group. For example if the Start Record is set at "-3", then the VIP will send the last three records in the selected group.
12. **Push Action:** Enables / disables the FTP Push operation. After you have selected FTP Push parameters, make certain to set the Push Action to On. The Push Action must be enabled in order for the FTP Push feature to function. (**Default = Off.**)
- Note:** If the Push Action feature is "Off", the selected FTP Push operation will not be performed.
13. **Periodic Push:** The amount of time that will elapse between FTP Push operations. This allows you to schedule the FTP Push feature to regularly transfer data to your FTP Server. For example, if the Periodic Push is set at 30 minutes, then every 30 minutes, the VIP will automatically transfer stored data to your FTP Server.  
(**1 to 9,999 Minutes, Default = 1,440 Minutes / 24 Hours.**)

### Notes:

- A periodic FTP Push operation will be delayed if targeted files are being accessed by another user at the time scheduled for data transfer. The VIP will delay the periodic push until the partition is released, or the other user exits command mode. If the delay lasts longer than the Xmit Delay period, the periodic push will be canceled.
  - A periodic push will not be performed if the specified files are empty (no data.)
14. **Xmit Attempts:** The number of times the VIP will attempt to retransmit data if the FTP operation fails. **(1 to 99 Attempts, Default = 5 Attempts.)**  
**Note:** The VIP will *not* perform additional transmit attempts if the specified file(s) are empty, or if the Server Address, User Name, Password, or Account info have not been supplied.
  15. **Xmit Delay:** The amount of time that will elapse between Transmit Attempts (Xmit Attempts.) **(1 to 99 Minutes, Default = 5 Min.)**
  16. **Auto Delete:** Enables/Disables the Auto Delete function for FTP Push operations. When enabled, the VIP will delete records from memory after the server acknowledges reception. **(Default = Off.)**
  17. **Start Time:** Specifies an exact start time for the next FTP Push operation as described in Section 16.4.2. **(Default = undefined.)**

### Miscellaneous:

21. **Force FTP Push:** When selected, the unit will immediately perform an FTP Push using parameters entered at items one through 16. If the partition (Source Port / Data Type) owned by the FTP Push feature is empty, the VIP will not attempt to connect to the Server. A Forced FTP Push will not effect the Periodic Push schedule.
22. **Test FTP Push:** Sends test data in order to determine if FTP Parameters are correctly set. If the Test FTP Push cannot establish a connection with the server, the VIP will display a message that describes the reason the test failed. (e.g. incorrect password.)  
**Note:** After you have selected new FTP Push parameters, it is recommended to use the "Test FTP Push" feature to make certain that newly defined parameters will work with your FTP server.
23. **Stop FTP Push:** Terminates any FTP Push operation in progress. Note that when this item is selected, the VIP will immediately terminate a Periodic Push or Force FTP Push.



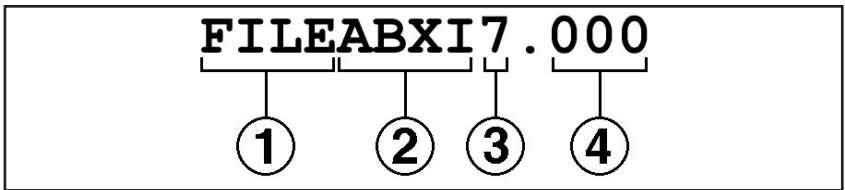

Figure 16.6: FTP Push File Names

### 16.4.1. File Names Created by FTP Push

When the FTP Push feature is used, the VIP will assign a name to the file that receives the data. This file name will be based on the user-defined, base file name, the source port, and data type. If desired, file names can also include an automatically incremented three character extension. As shown in Figure 16.6, the filename consists of the following components:

**Note:** This file naming convention applies only to data transferred by the FTP Push feature. A different file naming convention is employed when data is transferred using the FTP Server. For more information, please refer to Section 16.5.3.

- ① **File Name (Up to Four Characters):** The base file name defined via item 6 in the FTP Push Configuration menu. If the file name is not defined, the VIP will use the first three characters of the Site ID message. If the Site ID message is not defined, the letters "PNL" will be used. Note that if the file name is less than four characters, the remaining characters in this field will not be used.
- ② **Source Port (Up to Four Characters):** The VIP will enter from one to four characters to indicate which input port(s) originally received the data. The VIP will enter an "A" for PBX Port A, "B" for PBX Port B, "X" for the AUX Port, and/or "I" for the PBX IP Port. If fewer than four source ports are indicated, the remaining characters in this field will not be used.

- ③ **Data Type (One Character):** The selected Data Type (File Type.) The VIP will list the number for the data type selected at the FTP Push Configuration menu (see item 11 "Read Session.") These numbers are as follows:
1. **All:** Both Alarm Records and Non-Alarm Records.
  2. **Standard (Non-Alarm):** Only Non-Alarm Records.
  3. **Alarm Filter 1 (All):** All records that matched any clue defined for Alarm Filter 1.
  4. **Alarm Filter 1 (By Clue):** Only records that matched a specific clue defined for Alarm Filter 1.
  5. **Alarm Filter 2 (All):** All records that matched any clue defined for Alarm Filter 2.
  6. **Alarm Filter 2 (By Clue):** Only records that matched a specific clue defined for Alarm Filter 2.
  7. **All Alarms:** All records that matched any clue defined for either Alarm Filter 1 or Alarm Filter 2.

For example, if Data Type is defined as "All" (item 1) then the file name will have a "1" in this field.

- ④ **File Extension (Three Characters; Optional):** The VIP can append a sequentially numbered (000 to 999) three digit extension. This number will be incremented after each successful data transfer. If the Data Type or Source Port are changed, the file extension will be reset to "000".

#### Examples:

- If the File Name is defined as "DATA", and the FTP Push Configuration menu has been set to download all data (Option 1) received via PBX Port B (B), then the first file name written at the FTP server would be "**DATA B1 . 000**".
- If the File Name is defined as "PBX", and the FTP Push Configuration menu has been set to download Standard Data (Option 2) received via PBX Port A, PBX Port B, and the AUX Port (ABX), then the first file name written at the FTP server would be "**PBX ABX2 . 000**".
- If the File Name has not been defined, but the Site ID message is "ATLANTA", and the FTP Push Configuration Menu has been set to download all alarm data (Option 7) received via the AUX Port (X), then the first file name written at the FTP server would be "**ATLX7 . 000**".

### **16.4.2. FTP Push Start Time**

The "Start Time" parameter in the FTP Push Configuration menu allows you to specify an exact start time for an FTP Push operation. The Start Time is indicated using 24 hour (military clock) format. Note that the FTP Push operation specified by the FTP Push Start Time will be performed in addition to any Periodic Push actions that are defined, and that after the FTP Push Start Time elapses, additional Periodic Pushes will be scheduled relative to this user defined Start Time.

For example, assume that the periodic push value is 120 minutes (two hours.) Normally, the VIP might perform a periodic push at 1:30, 3:30, 5:30 and etc. However, if the FTP Push Start Time is then set at 4:00, the VIP will perform the 1:30 and 3:30 periodic pushes according to the previous schedule, but will then perform an additional FTP push at 4:00 (as specified by the FTP Push Start Time), the timer will then be reset, and the next periodic push will not occur until 6:00 (two hours after the start time,) and additional periodic pushes would be scheduled for two hour intervals after the FTP Push Start Time.

Providing that all FTP Server parameters are defined, and the real-time clock has been accurately set, the FTP Push Start Time will cause the unit to perform one FTP Push at the specified start time, and then reset the timer for Periodic Push operations. Once the FTP Push Start Time is selected, it will be applied once during the next 24 hour period, and that Start Time will effectively be established as the new "zero hour" for timing future periodic push operations.

**Note:** Although the FTP Push Start Time will normally only be observed once during the 24 hour period after it is first set, the FTP Push Start Time will also apply when any of the following events occur:

- When the FTP Push Start Time is defined or changed.
- When the "Push Action" parameter (FTP Push Configuration Menu, Item 12) is enabled or re-enabled.
- When the value for the "Periodic Push" parameter (FTP Push Configuration Menu, Item 13) is changed.
- When saved parameters are uploaded to the VIP unit as described in Section 15.2.
- When the VIP unit is powered Off, and then powered On again.

```
FTP SERVER CONFIGURATION:

FTP SERVER PARAMETERS
1.  UserName:      MARIO
2.  Password:     ZEBRA
3.  Filename:     TST
4.  Auto Delete:  Off
5.  Audit Trail:  On

MISCELLANEOUS
11. Stop FTP Session

Enter selection,
Press <ESC> to return to previous menu ...
```

Figure 16.7: FTP Server Configuration Menu (Defaults Shown)

---

## 16.5. The FTP Server Feature

---

The FTP Server feature enables the VIP unit to function like a standard FTP server. You can connect to the VIP using the FTP client program of your choice, and then select and retrieve files. In order to use this feature, your installation must include the following components:

- A network connection to the VIP unit. Note that the network must be running TCP/IP in order to use the VIP's FTP server function.
- An FTP client (e.g. DOS FTP, WS FTP, etc.) installed on the remote PC which will drive the data release.

### 16.5.1. Configuring the FTP Server Feature

To configure the FTP Server function, access command mode as described in Section 19.1. From the Main Menu, type **28** and press **[Enter]** to display the FTP Server Configuration menu (Figure 16.7.) This menu is used to define parameters that will be employed when a user attempts to create an FTP connection with the VIP unit. To define FTP Server Parameters, key in the number for the desired item, press **[Enter]**, then follow the instructions in the submenus. The FTP Server Configuration menu includes the following items:

#### FTP Server Parameters:

1. **User Name:** The name that a remote user will enter at their FTP program's connect menu or prompt in order to create an FTP connection to the VIP unit. (**Up to 16 Characters;**  
**Default = Undefined.**)
2. **Password:** The password that a remote user will enter at their FTP program's connect menu or prompt in order to create an FTP connection to the VIP unit. (**Up to 16 Characters;**  
**Default = Undefined.**)

3. **Filename:** The first four characters of the filename that the FTP Server function will assign to each category of data stored in buffer memory. The complete filename will consist of these four characters, one character which indicates the source port, and two characters which indicate the data type. For more information, see Section 16.5.3. (**Up to four characters; Default = Undefined.**)

**Note:** If you are using the FTP Server function to retrieve data from several different VIP units, a unique file name should be assigned to each unit. This will prevent the data from one unit from overwriting data from another unit.

4. **Auto Delete:** Enables / Disables the Auto Delete function for FTP Server operations. When enabled, the VIP will delete records from buffer memory after your FTP client acknowledges reception. (**Default = Off.**)

**Notes:**

- When Auto Delete is enabled, the VIP will only delete records after your FTP client acknowledges reception. If the data transfer is aborted or interrupted, the Auto Delete Function will not delete records from memory.
  - When Auto Delete is enabled, the unit will not display a prompt before deleting records from buffer memory.
5. **Audit Trail:** Enables / Disables the Audit Trail for FTP Server operations. When enabled, the VIP will create a log which lists all FTP connections, including the duration of the connection, password entered, and status at disconnection. (**Default = Off.**)

**Miscellaneous:**

11. **Stop FTP Session:** Aborts any FTP session currently in progress.

### 16.5.2. Retrieving Data Using FTP Server

Since the FTP Server feature will function with a variety of different FTP clients (e.g. DOS FTP, WS FTP, etc.), the exact procedure will differ slightly depending on the client used. Although this section describes the general concept for transferring data using the DOS FTP client, note that the general concept can also be applied to other FTP clients.

**Note:** When the FTP Server feature retrieves data, records cannot be selected according to the alarm clue matched.

1. From the DOS prompt at your remote PC, type **FTP ipaddress** and press **[Enter]** (where **ipaddress** is the IP address assigned to the VIP unit.) Note that the VIP's IP address is set using the Network Parameters menu as described in Section 5.4.5.
2. The FTP Server (the VIP) will acknowledge that a connection has been made, and that the VIP FTP server is ready. The FTP client will then prompt you to enter your username. Key in your username and then press **[Enter]**. Note that the username is defined using the FTP Server Configuration menu as described in Section 16.5.1.
3. If the valid username is entered, the FTP Server will return a message which indicates that the username was accepted. The DOS FTP client will then prompt you to enter your password. Key in your password and press **[Enter]**. Note that the password is defined using the FTP Server Configuration menu as described in Section 16.5.1.
4. If the valid password is entered, the FTP Server will return a message which indicates that the login was accepted, and the FTP client will display the "FTP>" prompt.

**Note:** The VIP will allow three attempts to enter a correct user name or password.

5. At the "FTP>" prompt, type **dir** and press **[Enter]**. The FTP Server (the VIP) will return a directory listing which indicates the names and status of the various files which contain the buffered call data.
  - a) Each file will contain a specific type of data, received from a specific VIP input port (e.g., PBX Port A.) The name of each file indicates the Data Type and Source Port for all records contained in the file. For more information on file names for the FTP Server function, please refer to Section 16.5.3.
  - b) The directory listing will also indicate the number of records in each file, and the "Free" status of each file. Any file which is currently partitioned to another user will be listed as "Locked."

6. Refer to the displayed file names, and select the file which contains the data that you need to retrieve. At the "FTP>" prompt, type **get filename** and press **[Enter]** (where **filename** is the name of the file which contains the data that you need.)
7. The FTP Server (the VIP) will return a series of response messages, and the selected file will be transferred to the current directory on your remote PC. To retrieve additional files, repeat step 6 above.
8. When you have finished retrieving files, type **bye** and press **[Enter]**. The FTP connection will be terminated.

```
c:\data\ ftp 192.168.168.168
Connected to 192.168.168.168.
220 NetLink FTP server ready.
User (192.168.100.236: (none)): WTI
331 User name okay, need password
Password:
230 Login accepted.
ftp> dir
200 PORT command successful.
150 Opening data connection.
File           Records    Status
testAST        1172     Locked
testAA1        990      Locked
testAA2         0        Free
testBST        1133     Locked
testBA1        706      Locked
testBA2         0        Free
testXST        1432     Free
testXA1         0        Free
testXA2         970      Free
226 Transfer complete.
ftp: 350 bytes received in 0.16 Seconds 2.19 Kbytes/sec.
ftp> get testXST
200 PORT command successful.
150 Opening data connection.
226 Transfer complete.
ftp: 107400 bytes received in 29.33 Seconds 3.66 Kbytes/sec.
ftp> bye
221 Goodbye
c:\data\
```

Figure 16.8: FTP Server Example

### FTP Server Example:

Figure 16.7 shows the commands and responses that might result when a DOS FTP client connects to the VIP FTP Server, and retrieves a file named "**testXST**". In Figure 16.8, note that all commands entered by the user are shown in bold text.

1. In the first line of Figure 16.8, the user invokes the FTP command at the DOS prompt, specifying the IP address for the VIP unit. Two response messages are then displayed to acknowledge the connection, and indicate that the server is ready.
2. The DOS FTP client then prompts for a username. The user keys in the username "**WTI**" and presses **[Enter]**. The FTP server responds with a message that verifies that the username was valid.
3. Next, the FTP client prompts the user to enter the password. The user keys in the password and then presses **[Enter]**. The FTP server then verifies that the Login was accepted. Note that the password is not echoed back to the FTP client, and is therefore not shown in this example.



4. When the FTP client displays the "ftp>" prompt, the user keys in the **dir** command and presses **[Enter]** to display the names of the files available for retrieval. The **dir** command also displays the number of records in each file, and the Locked/Free status of each file. Files that are listed as "Locked" are currently partitioned by another user.
5. In this example, the user wishes to retrieve the file that contains standard, non-alarm (ST) records that were received via the Auxiliary Port (X.) Therefore, the name of the file that must be retrieved is "**testXST**". For more information on file naming conventions for the FTP server function, please refer to Section 16.5.3. The user then checks the dir listing, locates the desired file, and checks to make certain that it is free.
6. At the "ftp>" prompt, the user keys in the "**get testXST**" command to retrieve the desired file. Several response messages are displayed to indicate that the PORT command was successful, the data connection was opened, and that the transfer is complete. The FTP speed statistics are then listed. At this point, the file "**testXST**" has been downloaded to the resident directory on the user's PC.
7. The FTP client displays the "ftp>" prompt again, and the user types "**bye**" and presses **[Enter]** to terminate the FTP session. This command is followed by a response message which indicates that the connection was successfully terminated.

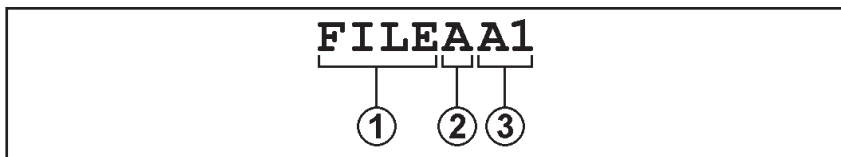

Figure 16.9: FTP Server File Names

### 16.5.3. File Names for the FTP Server Function

When your FTP program connects to the VIP unit, it will display a series of file names. Each file name denotes the type of data stored in the corresponding file. The file names generated by the FTP server function are based on the user-selected basic file name, the source port that collected the data, and the data type. As shown in the example in Figure 16.9, the file name will consist of the following components.

**Note:** This file naming convention applies only to the FTP Server function. A different convention is used when data is transferred using FTP Push. For more information, please refer to Section 16.4.1.

- ① **File Name (Up to Four Characters):** The base file name that is defined via item number 3 in the FTP Server Configuration menu. If the file name is not defined, the VIP will use the first three characters of the Site ID message. If the Site ID message has not been defined, the VIP will use the letters "PNL". Note that if the defined file name is less than four characters long, then the VIP will not use the remaining characters in this field.
- ② **Source Port (One Character):** The VIP will enter one character to indicate the port which originally received this data; the letter "A" indicates PBX Port A, "B" indicates PBX Port B, "X" indicates the AUX Port, and "I" indicates the PBX IP Port. Note that files created by the FTP Server Function will only contain data from *one* input port.
- ③ **Data Type (Two Characters):** The VIP will list one of three different data types: ST indicates that the file contains Standard (Non-Alarm) data, A1 indicates that the file contains records that matched Alarm Filter 1, and A2 indicates that the file contains records that matched Alarm Filter 2.

**Examples:**

- If the base file name is defined as "**TEST**", and the File contains standard, non-alarm data (**ST**) received via the AUX port (**X**), the file name would be "**TESTXST**".
- If the base file name is "**PBX**", and the file contains records that matched Alarm Filter 2 (**A2**), which were received via PBX Port B (**B**), then the file name would be "**PBXBA2**".
- If the base file name is not defined, but the site ID is "**ACME**", and the file contains records that matched Alarm Filter 1 (**A1**), which were received via PBX Port A (**A**), then the file name would be "**ACMAA1**".

#### **16.5.4. Commands Supported by FTP Server**

The FTP Server function supports the following FTP commands.

- **ABOR** - Aborts the current FTP operation.
- **DELE filename** - Deletes the specified filename from the FTP Server, where **filename** is the file you intend to delete. The **DELE** command can only be applied to the last file read.  
**Note:** If a file transfer is aborted before completion, the **DELE** command will still delete the target file, even though the file has not yet been transferred to your remote PC.
- **HELP cmdname** - Displays help information for the specified command (where **cmdname** is the target command.) If **cmdname** is omitted, then the **HELP** command will display a summary of all available FTP commands.
- **LIST** (Also **DIR** or **LS**) - Displays a listing of all files residing in the current directory at the FTP server.
- **NOOP** - (No Operation) Keeps the FTP connection alive without actually initiating a command function.
- **PASS password** - The FTP client uses this command to submit the user-entered password to the FTP Server (the VIP.)
- **PORT h1 , h2 , h3 , h4 , p1 , p2** - Sends the client's IP address and port number to the FTP Server, where **h1 , h2 , h3 , h4** is the IP address and **p1 , p2** is the port number.
- **PWD** - Displays the current active directory at the FTP Server.
- **QUIT** - Terminates the FTP connection.
- **RETR filename** - Retrieves the specified file from the FTP Server, where **filename** is the desired file.

- **SYST** - Displays the type of Operating System that is used by the FTP Server (e.g. Unix.)
- **TYPE [A|I]** - Specifies the type of file that is being transferred as either **A** (ASCII) or **I** (Image/Binary.)
- **USER username** - The FTP client uses this command to submit the entered username to the FTP Server.
- **XPWD** - Displays the currently active directory at the FTP Server.

### 16.5.5. Response Messages Generated by the FTP Server Function

The FTP Server function will send the following messages in response to commands issued by the FTP client:

#### Positive Preliminary Reply

150 Opening data connection.

#### Positive Completion Reply

200 Type set to A.  
200 Type set to I.  
200 PORT command successful.  
200 NOOP command successful.  
214 Syntax: ABOR (abort operation)  
214 Syntax: DELE <sp> filename  
214 Syntax: HELP [<sp> <string>]  
214 Syntax: LIST (return file list)  
214 Syntax: NOOP (no operation)  
214 Syntax: PASS <sp> password  
214 Syntax: PORT <sp> h1, h2, h3, h4, p1, p2  
214 Syntax: PWD (return current directory)  
214 Syntax: QUIT (terminate service)  
214 Syntax: RETR <sp> filename  
214 Syntax: SYST (get type of OS)  
214 Syntax: TYPE <sp> [A | I]  
214 Syntax: USER <sp> username  
214 Syntax: XPWD (return current directory)  
214 The following commands are currently supported:  
ABOR DELE HELP LIST NOOP PASS PORT  
PWD QUIT RETR SYST TYPE USER XPWD  
214 Direct comments to root.  
215 UNIX Type: WTI Server: "NetLink" OS: "WTIOS"  
220 NetLink FTP server ready.  
221 Goodbye.  
226 Transfer complete.  
226 Abort successful.  
230 Login accepted.  
250 DELE command successful.  
257 "/" is current directory.

### **Positive Intermediate Reply**

331 User name okay, need password.

### **Transient Negative Completion Reply**

421 Too many attempts, closing control connection.

425 Can't open data connection.

426 Can't build data connection: Connection refused.

426 Transfer aborted. Data connection closed.

### **Permanent Negative Completion Reply**

500 Invalid userid/password.

500 Syntax error (command unrecognized.)

501 Syntax error (invalid argument.)

502 Unknown help command.

530 Please login with USER and PASS.

530 Already logged in.

530 TYPE is not supported.

550 File can't be retrieved, partition set by  
other port.

550 File can't be deleted, partition is not set.

553 File doesn't exist.

553 File is empty.

## 16.6. The Auto Delete Function

---

When the Auto Delete option is enabled, the VIP will delete data from internal memory immediately after the polling device acknowledges reception.

### Notes:

- When Auto Delete is enabled, the "Hold End Data" function must also be enabled. The data release command must also specify the number of records that will be included in each read. This will ensure that data will not be deleted until reception is acknowledged.
- Do not invoke Command ^B07 (Continuous Binary Block Read) while Auto Delete is enabled, because the VIP will erase data without waiting for the polling device to acknowledge reception.
- When Auto Delete is enabled, data cannot be released according to the Clue Name matched.
- When Auto Delete is used with ASCII, Binary Block, or Xmodem data release, data is deleted in 16 kilobyte blocks. Auto Delete will not clear a block unless all data from the 16K block has been released. Therefore, if the user releases only part of a block, resets the partition, and then re- invokes the original data release command, records from the partial (undeleted) block will be released again.
- Auto Delete functions independently for each command port and for each FTP method. In other words, Auto Delete may be *enabled* for menu driven data retrieval via the Network Port, and at the same time, *disabled* for the FTP Push function.

## 16.7. Zmodem Data Release Mode

---

When using Zmodem to release data, make certain your communications program (e.g. ProComm) is set to prompt for a new file name when downloaded data is stored. This will prevent the communications program from accidentally overwriting data from the previous download. When the VIP's Auto Delete function is enabled, the "prompt for filename" option also prevents the unit from deleting unread data when ProComm's crash recovery feature is enabled.

# 17. Other Menu Functions

---

In addition to the configuration and polling features discussed previously, the VIP menu system also includes functions related to system management and diagnostics.

## 17.1. System Functions

---

The System Functions menu (Figure 17.1), is used to access features related to general system management.

### 17.1.1. Security Level

This function is used to switch between User Mode and Supervisor Mode. Access to Supervisor Mode is password protected. To change the Security Level proceed as follows:

1. From the Main Menu, type **3** and press **[Enter]** to access the System Functions Menu. When the System Functions Menu appears, type **1** and press **[Enter]**.
2. Select the Supervisor Mode or User Mode.
  - a) When Supervisor Mode is selected, the VIP will prompt the user to enter a password (Default = **SUPER**). Key in your valid Supervisor password and press **[Enter]**.
  - b) When User Mode is selected, the VIP will immediately switch to User Mode. A password prompt will not be displayed.

```
SYSTEM FUNCTIONS:
1. Security Level
2. "Passthrough" Mode
3. "Monitor" Mode
4. Clear Alarm Condition
5. Clear Alarm Clue Counters
6. Download Parameters
7. Audit Trail Functions
8. Upload Firmware

Enter selection,
Press <ESC> to return to previous menu ...
```

Figure 17.1: System Functions Menu

### 17.1.2. Pass-Through Mode

The Pass-Through Mode allows direct communication with device(s) connected to PBX Port A, PBX Port B, or the AUX Port. When communicating via the Console Port or Network Port, Pass-through Mode also allows communication with the device connected to the Modem Port.

#### Notes:

- While Pass-Through Mode is active, the VIP will not store additional data, and will not check for new records that match alarm clues.
- NLJ-VIP units do not include PBX Port B or the AUX Port.

To activate the Pass-Through Mode proceed as follows:

1. From the Main Menu, type **3** and press **[Enter]** to activate the System Functions menu.
2. From the System Functions menu, type **2** and press **[Enter]**. The VIP will prompt the user to specify a destination port. Key in the number for the desired port and press **[Enter]**.

**CAUTION: Do not attempt to alter PBX configuration unless you are authorized to do so. Please refer to the PBX user's guide for further instructions.**

3. To exit Pass-Through Mode and return to command mode, type **^B30** and press **[Enter]**.



### **17.1.3. Monitor Mode**

The Monitor Mode is similar to the Pass-Through Mode, in that it also allows direct communication with device(s) connected to PBX Port A, PBX Port B, the AUX Port, and the Modem Port. Note however, that while Monitor Mode is active, the VIP will store new PBX records and will continue to check for records that match Alarm Clues.

**Note:** NLJ-VIP units do not include PBX Port B or the AUX Port.

To activate the Monitor Mode proceed as follows:

1. From the Main Menu, type **3** and press **[Enter]** to access the System Functions menu.
2. From the System Functions menu, type **3** and press **[Enter]**. The VIP will prompt the user to specify a destination port. Key in the number for the desired port and press **[Enter]**.

**Note:** Obviously, the Modem Port cannot monitor the Modem Port. However, the Console Port and Network Port can monitor the Modem Port, allowing communication with another user connected to the unit via the Modem Port.

3. To exit Monitor Mode and return to command mode, type **^B30** and press **[Enter]**.

### **17.1.4. Clear Alarm Condition**

The "Clear Alarm Condition" function is used to cancel pending Alarm Actions. Note that this function will not clear Alarm Counters; therefore, additional records that match a counter which has passed the threshold will generate additional Alarm Actions.

**Example:** Assume that the counter for an Alarm Clue named "TEST" has exceeded its threshold and has generated five pending Alarm Actions. If the Clear Alarm Condition function is invoked, pending actions will be canceled, but the counter for TEST will not be reset. Any additional call records that match the TEST Clue will generate additional Alarm Actions.

To activate the Clear Alarm Condition function from the Main Menu, type **3** and press **[Enter]** to access the System Functions menu. From the System Functions Menu, type **4** and press **[Enter]**. All pending Alarm Actions will be canceled.

### **17.1.5. Clear Alarm Counters**

This function is used to reset Alarm Clue Counters to zero:

1. From the Main Menu, type **3** and press **[Enter]** to access the System Functions Menu. From the System Functions Menu, type **5** and press **[Enter]**.
2. The VIP will prompt the user to select Alarm Filter 1 or 2. Key in the number for the desired filter and press **[Enter]**.
3. The VIP will list all clues for the selected Alarm Filter.
  - a) To reset the counter for a specific Alarm Clue, key in the name of the desired clue and press **[Enter]**.
  - b) To reset counters for all clues for the selected Alarm Filter, type **\*** (asterisk) and press **[Enter]**.
  - c) To exit from the clue selector screen and return to the Alarm Filter selector screen, press **[Esc]**.

### **17.1.6. Download Parameters**

The Download Parameters function is used to save VIP parameters and configuration settings to an ASCII file. For more information on saving and restoring parameters, please refer to Section 15.2.

### **17.1.7. Audit Trail**

The Audit Trail Function displays a record of command activity at the Console Port, Modem Port, and/or Network Port. When a command port's Audit Trail function is activated, the VIP will create a log which lists command activity at that port.

Each activity record is time/date stamped and arranged in chronological order. The Audit Trail function uses flash memory to store records for up to 64 events. To create and review the Audit Trail, proceed as follows:

1. **Enable Audit Trail Log:** Go to the configuration menu for the desired port(s) (see Section 5.4), and enable the Audit Trail function. Item 15 in each command port configuration menu is used to enable/disable the Audit Trail.
2. **Log Actions:** After enabling the Audit Trail at the desired port, allow the port to log command actions. The VIP will only log activity at ports where the Audit Trail is enabled.
3. **Review Audit Trail Log:** To display Audit Trail records, access the System Functions menu (Main Menu, item 3). From the System Functions menu, type **7**, press **[Enter]** to display the Audit Trail Functions menu. The Audit Trail Functions menu offers the following options:
  - a) **Set Audit Trail Read Parameters:** This function selects the Start Record and Record Count. The Start Record determines where the data release will begin, and the Record Count determines how many records will be released at a time.
  - b) **Enter Audit Trail Read Session:** Displays log records as specified by the Audit Trail Read Parameters.
  - c) **Erase All Audit Trail Records:** Erases log records. Note that erased records cannot be recovered.

### 17.1.8. Upload Firmware

This function is used to upload VIP firmware updates. Updates can be uploaded to the VIP via modem or the Console Port. To upload firmware, proceed as follows:

1. Obtain the update file. Firmware modifications can either be mailed to the customer, or downloaded from WTI via modem. Place the disk or diskette in your drive and/or copy the file to your hard drive.
2. This upload procedure will erase all parameters from flash memory. If your VIP unit has the base memory option (512K, no SIMMs), the upload procedure will also erase all stored data. It is recommended to retrieve stored data and download parameters *before* beginning this procedure.
  - a) Access command mode. Poll the unit to retrieve all stored data as described in Section 15.
  - b) Use the Download Parameters function (see Section 15.2) to save all user- defined parameters.
3. Press **[Esc]** to return to the Main Menu. Select item 3 "System Functions". When the System Functions menu appears, type **8** and press **[Enter]** to activate the Upload Firmware function.
4. The VIP will display a screen which asks for confirmation before continuing with the upgrade. To proceed, type **1** and press **[Enter]**. The VIP will clear its internal memory. While erasing data, the VIP will require approximately 20 seconds for each SIMM installed. Do not enter additional commands during this time.
5. After flash memory is cleared, the VIP will display a screen that reads "Upload Program Upgrade, <ESC> to quit".
6. Use your communication program's upload function to transfer the upgrade firmware to the VIP unit via modem or the Console Port. Select ASCII file format, and then specify the filename and directory location for the firmware upgrade file.

**Note:** The Upload function will time-out after one minute of inactivity. If the function times out, type **1** and press **[Enter]** to continue, or press **[Esc]** to abort.

7. If the upload is successful, the VIP will prompt the user to continue the upgrade or abort.
  - a) **Upgrade:** To continue with the upgrade, type **1** and press **[Enter]**. The VIP will erase the previous firmware, move new firmware from data flash to program flash memory, calculate and store the new checksum, and reboot. Do not attempt to reconnect to the VIP until the RDY indicator blinks to indicate the process is complete.
  - b) **Abort:** To abort the procedure, type **2** and press **[Enter]**. At this point, stored data and parameters have already been erased; the abort command merely tells the VIP not to install new firmware.
8. **Incomplete Upload:** If the upload is interrupted, times-out, or if the file is corrupted during transfer, the VIP will display a screen which asks for user confirmation before proceeding. To proceed, type **1** and press **[Enter]**, then return to Step 6 above.
9. **Emergency Recovery:** In the rare event that the VIP's operating system becomes corrupted during installation, front panel indicators will blink five times and the unit will automatically switch to Emergency Recovery Mode. Please contact WTI Customer Service for further instructions as described in Appendix F.

When firmware upgrades are available, WTI will provide the necessary files via modem or mailed diskette. At that time, an updated User's Guide or addendum will also be available.

```
SYSTEM DIAGNOSTICS:
1. Load & Test Memory
2. Send Test Message
3. Test Pager
4. Send Test SNMP Trap(s)

Enter selection,
Press <ESC> to return to previous menu ...
```

Figure 17.2: System Diagnostics Menu

## 17.2. System Diagnostics

---

The System Diagnostics menu allows access to functions used to test memory, modem communication, pager, and SNMP Trap operation.

### 17.2.1. Load and Test Memory

This function tests the VIP's internal memory. When activated, the VIP will clear the internal data flash and load a test pattern which is used to verify memory conditions.

**CAUTION: When this test is performed, all data stored in the VIP's flash memory will be lost. Note, that user-defined parameters will not be effected.**

To initiate this test, go to the System Diagnostics menu, type **1** and press **[Enter]**. The VIP will display a confirmation prompt. To proceed with the test, type **Y**, press **[Enter]**, and wait for the test to be completed.

When the test is complete, the VIP will list all installed memory modules, along with the Pass/Fail status of each module. If test results indicate a memory error, please contact WTI Customer Service as described in Appendix F. To return to the System Diagnostics menu when the test is complete, press **[Esc]**.

### 17.2.2. Send Test Message

This function is used to test the modem transmitter. When the Send Test Message function is enabled, the unit will send a continuous test message which should be received by your PC. If the test message is not received, this could indicate that the VIP's modem is not transmitting properly.

To initiate this test, go to the System Diagnostics menu, type **2** and press **[Enter]**, a submenu will appear. Select "On" to enable the test. To exit the Send Test Message Mode, press **[Esc]**.

```

TEST PAGER
1. Phone #:      (undefined)
2. Pager ID #:  (undefined)
3. Type:        Alpha
4. Start Test

Enter Selection,
Press <ESC> to return to previous menu ...

```

Figure 17.3: Pager Test Menu

### 17.2.3. Test Pager

The Test Pager function sends a test message or number to your alphanumeric or numeric pager. When testing an alphanumeric pager, the VIP will send the message "Test Page from PollCat the VIP". When testing a numeric pager, the VIP can send a numeric message entered at the Phone Number prompt.

To initiate the pager test, go to the System Diagnostics menu, type **3** and press **[Enter]**. The VIP will display the screen shown in Figure 17.3. Enter parameters for the Pager Test as follows:

1. **Phone #:** The phone number for your numeric pager or alphanumeric pager service. Type **1**, press **[Enter]**, and follow the instructions in the submenu.
  - a) For numeric pagers, this prompt can specify both the pager number and a numeric "message". In this case the phone number is entered as follows:

**PHONENO@MESSAGENO#**

Where **PHONENO** is the pager number, and **MESSAGENO** is any user-selected number. For example, to dial 555-1212 and send the message "333", the phone number would be "5551212@333#".

2. **Pager ID #:** When testing an alphanumeric pager, this item defines the Pager ID number. Type **2**, press **[Enter]**, and follow the instructions in the submenu. Note that this prompt is not used when testing a numeric pager.
3. **Type:** Selects a numeric or alphanumeric pager test. Type **3**, press **[Enter]**, and follow the instructions in the submenu.
4. **Start Test:** After entering the appropriate information at the prompts, type **4** and press **[Enter]** to initiate the pager test. To cancel a test in progress, use the "Clear Alarm Condition" function as described in Section 17.1.4.

#### **17.2.4. Send Test SNMP Trap(s)**

This function will send a test SNMP trap to the network manager(s). In order to function, SNMP Managers must first be defined and selected as described in Section 5.4.5. When this function is executed, the VIP will send an SNMP Trap to each defined SNMP Manager.

### **17.3. Default Parameters**

---

Main Menu item 21 will reset all the VIP parameters to default settings. This function offers the option to include or omit network parameters and Alarm Filter and Data Filter configurations. To reset parameters to defaults, type **21**, press **[Enter]** and follow the instructions in the submenu.



## 18. TCP Port Options

---

The VIP offers three optional functions, which can be used when communicating with the unit via Telnet; the Telnet Pass-Through Mode, the Real Time Mode, and the Selective Read Mode. All of these options are selected by entering the appropriate Telnet Port Number in the Telnet command line, as described in the sections that follow.

### Notes:

- Telnet ports 23, 2001, and 3001 allow normal access to the VIP command mode. However, Port 3001 will transfer data using "Raw Socket" mode.
- Telnet Pass-Through Mode, Real Time Mode, and Selective Read Mode use the same System and User Passwords as are normally used to log on to the VIP.
- The Telnet Pass-Through Mode, Real Time Mode and Selective Read Mode all support XON/XOFF flow control.
- NLJ-VIP units do not include PBX Port B or the AUX Port.

### 18.1. Standard Telnet Protocol & Raw Socket Mode

---

The Telnet Pass-Through Mode, Real Time Mode, and Selective Read Mode all offer the option to send data using either Standard Telnet Protocol or Raw Socket Mode. The port number entered in the telnet connect command determines which protocol is used.

When Standard Telnet Protocol is used, the VIP will receive and reply to all IACs. When Raw Socket Mode is used, data is always sent "as is", and command echo is always enabled.

## 18.2. Telnet Pass-Through

---

The Telnet Pass-Through function allows users to communicate directly with devices connected to PBX Port A, PBX Port B, the AUX Port, the PBX IP Port, the Console Port, or the Modem Port. All VIP menu functions are disabled, and the only VIP command that will be recognized is ^B30 (Exit Pass-Through and Disconnect Telnet Session). In addition, data can be sent using either Standard Telnet Protocol or Raw Socket Mode.

When a Telnet connection is established, using the Telnet Pass-through option, the following events will occur:

1. Upon connection, the VIP will send the "POLLCAT NETLINK" message (and the site ID, if defined) and then wait for a password.
2. If a valid password is entered, the VIP will send the "READY" message, and will then allow communication with the device connected to the specified port.

### Port Numbers for Telnet Pass-Through Function

This function is activated when one of the following port numbers is included in the Telnet connect command.

#### Standard Telnet Protocol:

Telnet Port No.	Function
2101	Pass-Through to PBX Port A
2102	Pass Through to PBX Port B
2103	Pass-Through to AUX Port
2104	Pass-Through to Console Port
2105	Pass-Through to Modem Port
2106	Pass-Through to PBX IP Port

#### Raw Socket Mode:

Telnet Port No.	Function
3101	Pass-Through to PBX Port A, Raw Socket
3102	Pass-Through to PBX Port B, Raw Socket
3103	Pass-Through to AUX Port, Raw Socket
3104	Pass-Through to Console Port, Raw Socket
3105	Pass-Through to Modem Port, Raw Socket
3106	Pass-Through to PBX IP Port, Raw Socket

---

## 18.3. Real Time Mode

---

The Real Time Mode allows Telnet users to receive data as soon as it is collected from the PBX; as each data item is collected, it is sent directly to the user via Telnet. Data can be read from PBX Port A, PBX Port B, PBX IP Port or the AUX Port.

### Notes:

- In the Read Time Mode, data can be sent using either Standard Telnet Protocol, or Raw Socket Mode, depending on the port number entered in the Telnet connect command.
- If the buffer for the target port already contains data, the VIP will first send the buffered data, and then switch to Real Time Mode after the buffered data has been completely sent.
- In Real Time Mode, all VIP menus, status screens and ^Bnn commands are suppressed.
- In Real Time Mode, the Auto Delete function is always enabled.

When a Telnet connection is established using the Real Time Mode option, the following events will occur:

1. Upon connection, the VIP will send "POLLCAT-NETLINK" message (and the site ID, if defined), and then wait for a password.
2. If a valid password is entered, the VIP will send the "READY" message, and then wait for an XON from the user before beginning data release.
3. When an XON is received, the VIP will pause for 5 seconds (to wait for client software to be ready), then begin sending data.
4. The connection will remain open indefinitely, or until the client disconnects using their telnet software.
5. If the telnet session is disconnected (either due to a user command or accidentally), the VIP will store additional data in buffer memory as it would normally.

### **Port Numbers for the Real Time Mode**

The Real Time Mode is activated when one of the following port numbers is included in the Telnet connect command.

#### **Standard Telnet Protocol:**

<b>Telnet Port No.</b>	<b>Function</b>
2201	Real Time Mode; PBX Port A.
2202	Real Time Mode; PBX Port B.
2203	Real Time Mode; AUX Port.
2206	Real Time Mode; PBX IP Port

#### **Raw Socket Mode:**

<b>Telnet Port No.</b>	<b>Function</b>
3201	Real Time Mode; PBX Port A, Raw Socket.
3202	Real Time Mode; PBX Port B, Raw Socket.
3203	Real Time Mode; AUX Port, Raw Socket.
3206	Real Time Mode; PBX IP Port, Raw Socket

---

## 18.4. Selective Read

---

This function allows Telnet users to read a selected type of buffered data from the VIP unit. In other words, the Selective Read function automatically sets a data partition based on the port number specified in the Telnet connect command. Data can be selected according to data type and the VIP port which originally received the data. The following data types can be selected:

- **All:** Both alarm data and non-alarm data.
- **Standard:** Non-alarm data.
- **Alarm 1:** Data which matched Alarm Filter One.
- **Alarm 2:** Data which matched Alarm Filter Two.

### Notes:

- When the Selective Read Mode is active, all VIP command menus, status screens and ^Bnn commands will function normally.
- In Selective Read mode, Data can be sent in either Standard Telnet Protocol or Raw Socket Mode, depending on the port number entered in the Telnet connect command.
- The Selective Read Mode will use the polling parameters currently selected by the Network Port Configuration menu.
- If the Auto Delete function is enabled at the target input port, data will be automatically deleted as soon as the polling device acknowledges reception.
- A Partition will *not* be set if the desired data file is empty. Even though the partition is automatically set, it is recommended to invoke command ^B01 using the appropriate arguments for the desired data.

When a Telnet connection is established using the Selective Read option, the following events will occur:

1. Upon connection, the VIP will send "POLLCAT NETLINK" (and the site ID, if defined) and then wait for a password.
2. If a valid password is entered, the VIP will send the "READY" message, and set the data partition as specified by the port number used in the Telnet connect command.

### Port Numbers for Selective Read Function

The Selective Read function is activated when one of the port numbers, shown in the tables on the next page, are included in the Telnet connect command.

**Standard Telnet Protocol:**

<b>Telnet Port No.</b>	<b>Function</b>
2301	Selective Read; PBX Port A, All Data
2302	Selective Read; PBX Port B, All Data
2303	Selective Read; AUX Port, All Data
2306	Selective Read; PBX IP Port, All Data
2311	Selective Read; PBX Port A, Standard Data
2312	Selective Read; PBX Port B, Standard Data
2313	Selective Read; AUX Port, Standard Data
2316	Selective Read; PBX IP Port, Standard Data
2321	Selective Read; PBX Port A, Alarm 1 Data
2322	Selective Read; PBX Port B, Alarm 1 Data
2323	Selective Read; AUX Port, Alarm 1 Data
2326	Selective Read; PBX IP Port, Alarm 1 Data
2331	Selective Read; PBX Port A, Alarm 2 Data
2332	Selective Read; PBX Port B, Alarm 2 Data
2333	Selective Read; AUX Port, Alarm 2 Data
2336	Selective Read; PBX IP Port, Alarm 2 Data

**Raw Socket Mode:**

<b>Telnet Port No.</b>	<b>Function</b>
3301	Selective Read; PBX Port A, All, Raw Socket
3302	Selective Read; PBX Port B, All, Raw Socket
3303	Selective Read; AUX Port, All, Raw Socket
3306	Selective Read; PBX IP Port, All, Raw Socket
3311	Selective Read; PBX Port A, Standard, Raw Socket
3312	Selective Read; PBX Port B, Standard, Raw Socket
3313	Selective Read; AUX Port, Standard, Raw Socket
3316	Selective Read; PBX IP Port, Standard, Raw Socket
3321	Selective Read; PBX Port A, Alarm 1, Raw Socket
3322	Selective Read; PBX Port B, Alarm 1, Raw Socket
3323	Selective Read; AUX Port, Alarm 1, Raw Socket
3326	Selective Read; PBX IP Port, Alarm 1, Raw Socket
3331	Selective Read; PBX Port A, Alarm 2, Raw Socket
3332	Selective Read; PBX Port B, Alarm 2, Raw Socket
3333	Selective Read; AUX Port, Alarm 2, Raw Socket
3336	Selective Read; PBX IP Port, Alarm 2, Raw Socket

---

## 18.5. Multiple Telnet Connections

---

When the Telnet Pass-Through Mode, Real Time Read Mode, or Selective Read Mode are active, additional telnet connections will be allowed in some cases and denied in others as described below:

1. **Telnet Pass-Through Mode:** When the Telnet Pass-Through Mode is connected to the target Port (Port A, B, PBX IP or AUX), additional telnet connections will be allowed or denied as follows:
  - **Real Time Mode:** *Is not* allowed to connect to the target port.
  - **Selective Read Mode:** *Is allowed* to connect to the target port.
2. **Real Time Mode:** When the Telnet Real Time Mode is connected to the target port (Port A, B, PBX IP or AUX), additional telnet connections to the target port will be denied.
3. **Selective Read Mode:** When the Selective Read Mode is connected to the target port (Port A, B, PBX IP or AUX), additional Telnet connections will be allowed or denied as follows:
  - **Pass Through Mode:** *Is allowed* to connect to target port.
  - **Real Time Read Mode:** *Not* allowed to connect to target port.

### 18.5.1. Conflicts with Other Command Ports

When another user has accessed command mode via the Console Port, Modem Port, or Telnet Ports 23, 2001, or 3001, Telnet Pass-Through Mode, Real Time Read, and Selective Read Mode will behave as follows:

1. **Normal Pass-Through Mode:** If the Console Port, Modem Port, or Telnet Ports 23, 2001, or 3001 have activated normal Pass-Through Mode (non-Telnet; see Section 16.1.2.) to access the target port, Telnet connections will be handled as follows:
  - **Telnet Pass-Through Mode:** *Not* allowed to connect to port.
  - **Real Time Mode:** *Not* allowed to read data from target port.
  - **Selective Read Mode:** *Is* allowed to read data from target port.
  
2. **Partitioned Data:** If the Console Port, Modem Port, or Telnet Ports 23, 2001, or 3001 have used the VIP Configuration menus or ^Bnn commands to set a partition which includes data received from the target port, Telnet connections will be handled as follows:
  - **Telnet Pass-Through Mode:** *Is* allowed to connect to target port.
  - **Real Time Mode:** *Not* allowed to read data from target port.
  - **Selective Read Mode:** *Not* allowed to read data from target port.



# 19 .Command Reference Guide

---

## 19.1. Command Mode Access

---

When the VIP has been properly installed and configured, command mode can be accessed by a local PC connected directly to the Console Port, by a remote PC that communicates via modem, or via TCP/IP network.

### Notes:

- If the Site I.D. Message (System Parameters Menu, Item 4) has been defined, the Site I.D. will be displayed before the "PollCat-NetLink" prompt.
  - When the Supervisor Password is entered, the VIP will start up in Supervisor Mode, allowing access to all menu functions. When a User password is entered, the VIP will start up in User Mode, which allows limited access to menu functions.
  - The Default Supervisor Mode Password is **SUPER**, and the default User Mode Password is **SMDR**.
1. **Remote Access (via Modem):** Start your communications program and dial the VIP.
    - a) The unit will respond with the "PollCat-NetLink" (password) prompt after the carrier is detected.
    - b) Key in a valid password and press **[Enter]**. Note that the Password feature is case-sensitive.
    - c) The Main Menu or the "Ready" prompt will be displayed. If the "Ready" prompt is displayed, press **[Enter]** to display the VIP Main Menu.
  2. **Local Access (Console Port):** Start your communications program.
    - a) If Set-Up Switch 7 is UP (Enable Console Port Password), the "PollCat- NetLink" (password) prompt will be displayed.
    - b) Key in a valid password and press **[Enter]**. Note that the Password feature is case-sensitive.
    - c) The Main Menu or the "Ready" prompt will be displayed. If the "Ready" prompt is displayed, press **[Enter]** to display the VIP Main Menu.

3. **Access via TCP/IP Network:** If network parameters for the VIP unit have been assigned (see Section 5.4.5), establish a telnet session using the following format:

```
telnet ipaddress [port] [Enter]
```

Where:

**ipaddress** The VIP's assigned IP Address.

**port** (Optional) The desired Port Number. If this item is omitted, telnet will connect to port #23 by default; Command Echo will be set according to the VIP's current configuration, and \$FF Stuffing will be enabled. Options:

- 2001** Behaves the same as Port #23.
- 3001** Preconfigured with echo enabled and \$FF Stuffing Off.

- a) If the password is enabled, the "PollCat-NetLink" (password) prompt will appear.
- b) Key in a valid password and press **[Enter]**. Note that the Password feature is case-sensitive.
- c) After a brief pause, the Main Menu or the "Ready" prompt will appear. If the "Ready" prompt is displayed, press **[Enter]** to display the VIP Main Menu.
- d) To end a session, disconnect using your Telnet software.

## 19.2. Command Syntax

---

Most commands conform to the following conventions:

- Commands normally begin with the ASCII "Control B" character (written as **^B** throughout this manual).
- To temporarily suppress the Command Echo for any command, use the **^A** character in place of the **^B** character. For example, if Command Echo is enabled and Command **^B03** (Send Site ID) is invoked, the VIP will echo the command back to the polling device and send the Site ID message. If **^A** is substituted for **^B** (e.g. **^A03**), the Site ID message will be sent, but the command will *not* be echoed back to the polling device.
- Each command is invoked by pressing the **[Enter]** key.
- A comma (,) is used to separate a command from its options or parameters (e.g. **^B01,10**).
- NLJ-VIP units do not include PBX Port B or the AUX Port.

## 19.3. Command Help

To display the Command Help screen shown in Figure 19.1, go to the Main Menu, type **5** and press **[Enter]**. To display additional command help, go to the Command Help screen, type **A** and press **[Enter]**. The screen shown in Figure 19.2 will be displayed.

```

^Bxx COMMAND HELP:

^B00 Set/Reset Memory Partition          ^B20 Display Partition Record/Block Ct
^B01 Enter Data Read Mode                ^B21 Display Remaining Space
^B02 Send Next Data                     ^B22 Display Capacity & PEX Baud
^B03 Display Site ID                    ^B24 Display DIP Switch Settings
^B04 Define Site ID Message              ^B25 Erase Partition Data
^B05 Define End Character                 ^B26 Display "Separator" Line
^B06 Re-Send Last Data                   ^B27 Enter Test Message Mode
^B07 Continuous Binary Block Read        ^B28 Enter Echo Test Mode
^B08 Display Current Alarm Record        ^B29 Enter Passthrough Mode
^B09 Exit Cmd Mode, Disconnect           ^B30 Exit, Return To Command Mode
^B11 Set Real Time Clock/Calendar        ^B39 Erase All Data
^B13 Display Site ID/Alarm Messages      ^B50 Default Parameters
^B16 Display System Status               ^B51 Select Store Alarm Data
^B17 Display PBX Inact Parameters        ^B52 Enable/Disable Hold End Data
^B18 Display Reason For Action           ^B53 Enable/Disable Data Compression
^B19 Display Action Schedule              ^B54 Enable/Disable Data on ^B01
                                          ^B55 Strip Non-printable Codes

A. More ^Bxx Command Help

Enter selection,
Press <ESC> to return to previous menu ...

```

Figure 19.1: Command Help Screen

```

MORE ^Bxx COMMAND HELP:

^B56 Select Data Filters                  ^B76 Release Remote Partition
^B57 Enable/Disable XON/XOFF              ^B77 Define Modem Init Message
^B59 Enable/Disable Line ID              ^B78 Display Modem Messages
^B60 Define Console/Modem bits-parity    ^B79 Define/Display Passwords
^B61 Define PBX Ports bits-parity        ^B83 Display Alarm Clue Summary
^B62 Select Output Format                 ^B84 Clear Alarm Condition
^B64 Enable/Disable Wrap Around           ^B86 Reset Alarm Clue Counters
^B65 Select Alarm Filters                 ^B89 Test Alpha Pager
^B66 Enable/Disable Time/Date Stamp       ^B90 Define/Reset Modem Port
^B67 Enable/Disable Auto Delete           ^B91 Define Console Port Comm
^B68 Enable/Disable Command Echo         ^B92 Define PBX Port A Comm
^B70 Define/Enable/Disable Immediate      ^B93 Define PBX Port B Comm
and 80% Callout                          ^B94 Enter Monitor Mode
^B71 Enable/Disable DLE Stuffing          ^B95 Display Program Version
^B72 Display Time, Day, Date              ^B96 Define AUX Port Comm
^B73 Send Binary Information Block        ^B97 Define/Display Network Parameters
^B74 Save/Recall Parameters              ^B98 Reset Network Port
^B75 Enable/Disable "SURE? (Y/N)"        ^B99 Download Current Parameters

Press <Esc> for previous screen ...

```

Figure 19.2: More Command Help

## 19.4. Command Summary

---

### **^B00 Set/Reset Memory Partition**

---

Sets or releases the memory partition for your command port.

#### **Notes:**

- If this command does not include an argument, the partition will be set to include all data by default.
- The Release partition argument (**R**) cannot be combined with other arguments.
- The ^B00 command line can specify two source ports (e.g. ^B00,PA,PB), but *cannot* specify two data types.
- Square brackets are not included in the command line. They are shown here to indicate an option.
- PBX Port B and the AUX port are not present on NLJ-VIP units.

Command ^B00 uses one of the following formats:

**^B00 [ ,type ] [ ,source ] [Enter] or ^B00 [ ,R ] [Enter]**

Where:

- ,type**     **Data Type:** Offers the following options:
- ,D** or **,STD**     Standard (Non-Alarm) Records.
  - ,A1** or **,A**     Records that match Alarm Filter 1.
  - ,A2**     Records that match Alarm Filter 2.
  - ,ALM**     Include All Alarm Records.
  - (Not Specified)     Include all data.
- ,source**     **Source Port:** Offers the following options:
- ,PA**     Records received via PBX Port A.
  - ,PB**     Records received via PBX Port B.
  - ,PX**     Records received via the AUX Port.
  - ,PI**     Records received via the PBX IP Port.
  - (Not Specified)     Records from all four ports.
- ,R**     **Release Data Partition:** The "R" option cannot be combined with other ^B00 arguments.

#### **Examples:**

- ^B00,D**     Set partition to include all records that did not match an Alarm Clue, regardless of the Input Port that received them.
- ^B00,A1,PX**     Include records that match Alarm Filter 1, and were received via the AUX Port.
- ^B00,R**     Release the current data partition.

**Corresponding Menu Function:** Buffer Functions, Items 2 and 3.

---

**^B01 Enter Data Release Mode**

---

Releases data collected from the PBX.

**Notes:**

- When data is released in groups of "n" records (e.g., ^B01,30), command ^B02 is sent to release the next group.
- To exit Data Release Mode and return to command mode, type ^B30 [Enter].
- If the XON/XOFF function is enabled at the appropriate port, the VIP will respond to XON/XOFF flow control codes during data release mode.
- If "Data on ^B01" is disabled, and ^B01,n is invoked to release data in groups of "n" records, a ^B02 is required in order to release the first group.
- If "Hold End Data" is enabled, a ^B02 is required in order to release the End Data message.
- PBX Port B and the AUX port are not present on NLJ-VIP units.

**Command Options:**

When Command ^B01 is invoked, the following format is used:

**^B01 [ , type ] [ , source ] [@n ] [ , n ] [Enter]**

Where:

- , type**    **Data Type:** Offers the following options:
- ,D** or **,STD**    Standard (Non-Alarm) Records.
  - ,A** or **,A1**    Records for Alarm Filter 1.
  - ,A2**    Records for Alarm Filter 2.
  - ,ALM**    Records for both Alarm Filters.
  - , "clue"**    Records for **clue** only. The clue name must be enclosed in quotes.
- , source**    **Source Port:** Offers the following options:
- ,PA**    Records received via PBX Port A.
  - ,PB**    Records received via PBX Port B.
  - ,PX**    Records received via AUX Port.
  - ,PI**    Records received via the PBX IP Port.
- @n**    **Offset:** Data release starts with the "nth" record. For example, ^B01@50 will start with the 50th record. If a negative offset value is entered, the VIP will determine the starting point by counting backwards from the end of the current partition.
- ,n**    **Count:** Releases records in groups of "n", where n is a positive, whole number.

## **^B01 Data Release Mode (Continued)**

### **Notes:**

- If both Alarm Filters include a clue with the same name, the command must specify the desired filter. For example, if Alarm Filters 1 and 2 both include a clue named **TEST**, to retrieve data from filter 1, the command line would read **^B01 ,A1 , "TEST"**.
- Each command option is preceded by a comma, with the exception of the Offset option (**@n**). This option is preceded by the "@" character. Do not enter a comma before the @ character.
- When Binary Block Mode is used, commands will release blocks instead of individual records.
- Square brackets are *not* included in the command line. They are shown here to indicate an option.

Options can also be combined. For example, **^B01 , "clue" ,n** will release records for clue in groups of **n** records or blocks.

**Corresponding Menu Function:** Main Menu, Item 2.

---

## **^B02 Send Next Data**

When Command **^B01,n** is invoked, the VIP will release a group of "n" records or blocks and then pause. To display the next group, type **^B02 [Enter]**. Command **^B02** is only valid in Data Release Mode and cannot be used in an Auto Execute string.

### **Notes:**

- If "Data on ^B01" is disabled, a **^B02** is required in order to release the first group of records.
- If "Hold End Data" is enabled, a **^B02** is required in order to release the End Data message.

---

## **^B03 Display Site ID**

Displays the user-defined Site ID message. Type **^B03 [Enter]**.

**Corresponding Menu Function:** Status Displays, Item 3.

---

**^B04 Define Site ID**

---

**(Supervisor Mode Only)** Defines a Site ID Message up to 32 characters long. Type **^B04 ,text** and press **[Enter]** (where "text" is the desired Site ID). The Site ID cannot include quotes or ASCII control characters (e.g. STX, ETX). If the Site ID begins with an underscore character ("\_"), upon login, the message will be displayed *after* the command prompt. To clear the Site ID, type **^B04 , [Space]** and press **[Enter]**.

**Notes:**

- The "\_" character will not appear in the displayed Site ID Message.
- If the Console Port Password is disabled (Sw7=Down), the Site ID Message will not be displayed when the unit is contacted via the Console Port.

---

**^B05 Define End-of-Record Character**

---

**(Supervisor Mode Only)** Redefines the End-of-Record (EOR) character that the VIP expects to see at the end of each record (**Default=^J**). Command **^B05** uses the following format:

**^B05 [ ,port] [ ,char] [Enter]**

Where:

- ,port**     **Input Port:** If this argument is omitted, **^B05** will define the EOR character for PBX Port A by default. Offers the following options:
- ,A**        PBX Port A
  - ,B**        PBX Port B (not available on NLJ-VIP)
  - ,X**        AUX Port (not available on NLJ-VIP)
  - ,I**        PBX IP Port
- ,char**     **EOR Character:** If a space character is entered, the EOR character for the target port will be cleared.

**Corresponding Menu Function:** Port Configuration menus (PBX Port A, PBX Port B, AUX Port, PBX IP Port), Item 14.

---

**^B06 Re-send Last Data**

---

This command is used in the event of a transmission error during the previous read. Command **^B06** will only function when **^B01 ,n** is invoked, or when the Record Count option (Read Session Parameters) is used. To re-send data, type **^B06 [Enter]**.

## **^B07 Continuous Binary Block Read**

---

Initiates a continuous binary block read, regardless of the output mode setting. Blocks are sent continuously, without acknowledgment, and cannot be retransmitted during the current read session. When transmitting via modem, error correction must be enabled. A DOS program is available to convert binary data to ASCII. The following settings are automatically used:

Output Mode:	Binary Block
Line ID (Block #) Tag:	Off
DLE Stuffing:	On
Auto-Delete:	Off

When command ^B07 is invoked, the following format is used:

**^B07 [ , type ] [ , source ] [ @n ]**

Where:

- , type**    **Data Type:** Offers the following options:
- ,D** or **,STD**    Standard (Non-Alarm) Records.
  - ,A** or **,A1**    Records for Alarm Filter 1.
  - ,A2**    Records for Alarm Filter 2 only.
  - ,ALM**    Records for both Alarm Filters.
  - ,"clue"**    Alarm Records for clue only. Note that the clue name must be enclosed in quotes.
- , source**    **Source Port:** Offers the following options:
- ,PA**    Records received via PBX Port A.
  - ,PB**    Records received via PBX Port B.  
(not available on NLJ-VIP)
  - ,PX**    Records received via AUX Port.  
(not available on NLJ-VIP)
  - ,PI**    Records received via PBX IP Port.
- @n**    **Offset:** Releases records starting with the "nth" record. For example, if **^B01@234** is entered, the VIP will start with the 234th record. If a negative offset value is entered, the VIP will determine the starting point by counting backwards from the end of the current partition.

**CAUTION:** Do not invoke Command ^B07 while the Auto Delete option is enabled. If ^B07 is invoked with Auto Delete enabled, the VIP will erase data without waiting for the polling device to acknowledge reception.



---

**^B07 Continuous Binary Block Read (Continued)****Notes:**

- To exit Continuous Binary Block Read and return to Command Mode, type **^B30 [Enter]**.
- If both Alarm Filters include an identical clue name, the command must specify the desired filter. For example, if Alarm Filters 1 and 2 both include a clue named **TEST**, to retrieve data from filter 1, the command line would read **^B07 ,A1 , "TEST"**.
- Each option is preceded by a comma, with the exception of the Offset option (**@n**). This option is preceded by the "@" character. Do not enter a comma before the @ character.
- While Continuous Binary Block Read is active, the VIP will respond to XON/XOFF flow control codes.
- Square brackets are *not* included in the command line. They are shown here to indicate an option.

Options can also be combined. For example, **^B07 ,PA ,D** will release all records received via PBX Port A, that did *not* match an Alarm Filter.

---

**^B08 Display Current Alarm Record**

---

Displays the last record that triggered an alarm. Type **^B08** and press **[Enter]**.

---

**^B09 Exit Command Mode (Disconnect/HangUp)**

---

Exits from command mode, discontinues connection to the VIP, and resets the internal modem. To exit and disconnect, type **^B09 [Enter]**.

**Corresponding Menu Function:** Main Menu, item 8.

---

**^B11 Set Time / Date**

---

**(Supervisor Mode Only)** Sets the VIP's real-time clock and calendar. Command **^B11** uses the following format:

**^B11 ,hh :mm ,d ,MM\DD\YY [Enter]**

Where:

- hh** Is the Hour (00 to 23)
- mm** Is the Minute (00 to 59)
- d** Is the day of the week (1=Sun., 2=Mon., 3=Tue., etc.)
- MM** Is the Month (01 to 12)
- DD** Is the Date (01 to 31)
- YY** Is the Year (00 to 99)

**Corresponding Menu Function:** System Parameters, Item 6.

### **^B13 Display Site ID Message / Alarm Message**

---

Displays the user-defined Site ID Message, along with the name of any clue that is in the alarm state, and the status of the counter for that clue. Type ^B13 and press [Enter].

**Corresponding Menu Function:** Status Displays, Items 31 through 38.

### **^B16 Display System Status**

---

Displays a screen which lists the status of most options and parameters. Type ^B16 [Enter].

**Corresponding Menu Function:** Status Displays, item 3.

### **^B17 Display PBX Inactivity Alarm Parameters**

---

Displays currently defined PBX Inactivity Alarm parameters. When the argument is omitted, the command will display parameters for Alarm 1 by default.

#### **Command Options:**

- ^B17,1 Display Parameters for PBX Inactivity Alarm 1 (**Default**).
- ^B17,2 Display Parameters for PBX Inactivity Alarm 2.

**Corresponding Menu Functions:** Status Displays, item 11 (Alarm 1); Status Displays, item 12 (Alarm 2).

### **^B18 Display Reason For Action**

---

When the VIP has generated an Alarm Action, Command ^B18 can be used to determine the reason. After receiving an Alarm Action, type ^B18 and press [Enter].

**Corresponding Menu Function:** Status Displays, Item 15.

### **^B19 Display Action Schedule**

---

Displays parameters for the Scheduled Actions. If the argument is omitted, the command will display Schedule 1 by default.

#### **Command Options:**

- ^B19,1 Display Parameters for Action Schedule 1 (**Default**).
- ^B19,2 Display Parameters for Action Schedule 2.

**Corresponding Menu Functions:** Status Displays, item 4 (Schedule 1); Status Displays, item 5 (Schedule 2).

---

### **^ B20 Display Partition Record Count**

---

Displays the number of records in your port's current memory partition. Type **^B20** and press **[Enter]**.

**Corresponding Menu Function:** Status Displays, Item 1

---

### **^ B21 Display Remaining Space**

---

Displays the approximate amount of memory (in characters/bytes) that is currently available. Type **^B21** and press **[Enter]**.

**Corresponding Menu Function:** Status Displays, Item 1.

---

### **^ B22 Display Memory Capacity & PBX Port Baud Rate**

---

Lists installed memory modules, total memory capacity, and PBX Port communication parameters. Type **^B22** **[Enter]**.

**Corresponding Menu Functions:** Status Displays, Items 1, 21, and 22.

---

### **^ B24 Display DIP Switch Settings**

---

Displays the up/down configuration of the VIP's Set-Up Switches; type **^B24** and press **[Enter]**.

**Corresponding Menu Function:** Status Displays, item 3.

---

### **^ B25 Erase Partition Data**

---

Clears all call records in your port's current memory partition; type **^B25** and press **[Enter]**.

If the "Sure" option is enabled, a prompt will be displayed before this command is completed. Type **Y** to proceed or **N** to abort, and then press **[Enter]**.

**CAUTION:** Erased records cannot be recovered.

#### **Command Options:**

- ^B25**      Display "Sure" prompt (if enabled), Erase Partition Data.
- ^B25, Y**    Suppress "Sure" prompt, Erase Partition Data.

**Corresponding Menu Function:** Buffer Functions, Item 5

### **^B26 Display Separator Line**

---

Creates a line of dashes that can be used to visually separate displayed material. To send a line of dashes, type **^B26 [Enter]**.

### **^B27 Enter Test Message Mode**

---

Tests the modem transmitter. When Command ^B27 is invoked, the unit will send a continuous test message. To initiate the test, type **^B27** and then press **[Enter]**. To terminate the test, type **^B30 [Enter]**.

**Corresponding Menu Function:** System Diagnostics, item 2.

### **^B28 Enter Echo Test Mode**

---

Tests the modem receiver. When Command ^B28 is invoked, the VIP will echo back a test character. If characters are not echoed back, this can indicate that the modem is not receiving properly. To initiate the test, type **^B28 [Enter]**. To terminate the test, type **^B30 [Enter]**.

### **^B29 Enter Pass-through Mode**

---

**(Supervisor Mode Only)** Allows direct communication with a connected device. Data can be received directly from the PBX in order to check for correct reception. Commands can also be sent directly to the PBX. While Pass-Through Mode is active, additional call records will *not* be stored. To exit Pass-Through Mode, type **^B30** and press **[Enter]**.

**CAUTION: Do not attempt to alter PBX configuration unless you are authorized to do so. Please refer to the PBX user's guide for further instructions.**

#### **Command Options:**

- ^B29, A** Pass-Through to PBX Port A.
- ^B29, B** Pass-Through to PBX Port B  
(not available on NLJ-VIP).
- ^B29, X** Pass-Through to AUX Port.  
(not available on NLJ-VIP)
- ^B29, I** Pass-Through to PBX IP Port.
- ^B29, C** Pass-Through to Console Port.
- ^B29, M** Pass-Through to Modem Port.

**Corresponding Menu Function:** System Functions, item 2.

### **^B30 Exit, Return to Command Mode**

---

Exits from Data Release Mode, Send Continuous Test Message Mode, Echo Test Mode, Pass-Through Mode, or Monitor Mode and returns to command mode. Type **^B30 [Enter]**.

---

**^B39 Erase All Data**

---

Erases all stored data, including records stored outside your port's memory partition. Command ^B39 includes an option that allows the user clear all data *and* reset all Alarm Clue Counters to zero.

**CAUTION: Erased call records cannot be restored.**

If the "Sure" option is enabled, a prompt will be displayed. Type **Y** to proceed, or **N** to abort, and then press **[Enter]**.

**Command Options:**

- ^B39** Clear all records, leave Alarm Clue Counters intact.
- ^B39, 2** Clear all records *and* reset Clue Counters to zero.
- ^B39, Y** Suppress "Sure" prompt, Clear all records, leave Alarm Clue Counters intact. Note that the Y argument can also be combined with the "2" argument (e.g., **^B39, 2, Y**).

**Corresponding Menu Function:** Buffer Functions, item 6.

---

**^B50 Default Parameters**

---

**(Supervisor Mode Only)** Resets options and parameters to default settings. When this command is invoked, the input ports and command ports are reset to the baud rate selected by the Set-Up Switches; the modem port is reset to 57600 bps, 8 bits, no parity, one stop bit.

**CAUTION: Options, parameters, and filters that have been erased cannot be automatically restored.**

If the "Sure" option is enabled, a prompt will be displayed. Type **Y** to proceed, or **N** to abort, and then press **[Enter]**.

**Command Options:**

- ^B50** Reset options and parameters to default state.
- ^B50, 2** Reset options and parameters to default state. Erase Data Filter Format, Data Filter Parameters, Alarm Filter Format, Alarm Clues, and reset Alarm Clue Counters to zero.
- ^B50, Y** Suppress "Read in Progress" prompt and "Sure" prompt, reset options and parameters to default state. Note that the "Y" argument can also be combined with the "2" argument (e.g., **^B50, 2, Y**).

**Corresponding Menu Function:** Main Menu, item 21.

## **^B51 Store Alarm Data**

---

**(Supervisor Mode Only)** Allows the user to determine where alarm data will be stored. The VIP can either store alarm records in the Alarm File (default), in the Standard (non-alarm) File, or in both files. Command ^B51 uses the following format:

**^B51 [ ,port ] [ ,file ] [Enter]**

Where:

- ,port**     **Input Port:** If this argument is omitted, ^B51 will select the alarm data storage location for PBX Port A by default.
- ,A**        PBX Port A
  - ,B**        PBX Port B (not available on NLJ-VIP)
  - ,X**        AUX Port (not available on NLJ-VIP)
  - ,I**        PBX IP Port
- ,file**     **Storage Location:** Determines where Alarm Data from this port will be stored. Offers the following options:
- ,1**        Alarm File. **(Default)**
  - ,2**        Standard File.
  - ,3**        Both the Alarm File and Standard File.

**Corresponding Menu Function:** Port Configuration Menus, Item 16.

## **^B52 Enable/Disable End Data Message**

---

Configures the unit to either hold or release the "END DATA" message. When "Hold End Data" is selected, the message will be held until a ^B02 is received. Note that this command will only effect the port that invoked the command.

**Command Options:**

- ^B52 , 1**   Release End Data Message
- ^B52 , 3**   Hold End Data Message **(Default)**

**Corresponding Menu Function:** Port Configuration Menus, Item 23.

## **^B53 Set Compression Mode**

---

Determines whether data will be released in space compressed format, or normal format. Note that this command will only effect the port that invoked the command.

**Command Options:**

- ^B53 , 1**   Release Data in Compressed Format.
- ^B53 , 2**   Release Data in Decompressed Format (Default)

**Corresponding Menu Function:** Port Configuration Menus, Item 25.

---

**^B54 Release Data on ^B01**

---

Determines how the VIP will react when Command ^B01,n is invoked to release data in groups of "n". Note that this command will only effect the port that invoked the command.

**Command Options:**

- ^B54,1** Release First Group without ^B02 (**Default**).
- ^B54,2** Wait for Command ^B02.

**Corresponding Menu Function:** Command Port Configuration Menus, Item 22.

---

**^B55 Strip Non-Printable Codes**

---

**(Supervisor Mode Only)** Conserves memory by omitting non-printable characters, such as NULs, DELs, and etc. The VIP will remove most non-printable characters except carriage returns, line feeds, and the selected EOR character. This command uses the following format:

**^B55 [ ,port ] [ ,action ] [Enter]**

Where:

- ,port** **Input Port:** If this argument is omitted, ^B55 will set the Strip Non-Printable codes option for PBX Port A. Options:
- ,A** PBX Port A
  - ,B** PBX Port B (not available on NLJ-VIP)
  - ,X** AUX Port (not available on NLJ-VIP)
  - ,I** PBX IP Port
- ,action** **Store/Strip Codes:** Offers the following options:
- ,1** Store Non-Printable Codes (**Default**)
  - ,2** Strip Non-Printable Codes

**Corresponding Menu Function:** Input Port Configuration Menus, Item 13.

## **^B56 Select Data Filters**

---

**(Supervisor Mode Only)** Determines which data filter will be used for each input port. This command uses the following format:

**^B56 [ ,port ] [ ,filter ] [Enter]**

Where:

**,port** **Input Port:** If this argument is omitted, ^B56 will assign the selected filter to PBX Port A. Options:

- ,A** PBX Port A
- ,B** PBX Port B (not available on NLJ-VIP)
- ,X** AUX Port (not available on NLJ-VIP)
- ,I** PBX IP Port

**,filter** **Data Filter:** Selects or disables the Data Filter. The following options are available:

- ,1** Disable Data Filter at Selected Port (**Default**)
- ,2** Assign Data Filter 1 to Selected Port
- ,3** Assign Data Filter 2 to Selected Port

**Corresponding Menu Function:** Input Port Configuration Menus, Item 17.

## **^B57 Enable / Disable XON / XOFF Function**

---

**(Supervisor Mode Only)** The VIP can send an XOFF when memory becomes 98% full, and an XON when more data can be accepted.

Command ^B57 uses the following format:

**^B57 [ ,port ] [ ,action ] [Enter]**

Where:

**,port** **Input Port:** If this argument is omitted, ^B57 will apply the selected action to PBX Port A. Options:

- ,A** PBX Port A
- ,B** PBX Port B (not available on NLJ-VIP)
- ,X** AUX Port (not available on NLJ-VIP)
- ,I** PBX IP Port

**,action** **Enable / Disable:** Offers the following options:

- ,1** Enable XON/XOFF at Selected Port
- ,2** Disable XON/XOFF at Selected Port (**Default**)

**CAUTION:** Some PBX switches may lock up when XON/XOFF is used. Other PBX switches will not respond to XON/XOFF commands. Consult your PBX User's Guide before attempting to employ this feature.

**Corresponding Menu Function:** Input Port Configuration Menus, Item 4.



**^B59 Line ID Option**

Inserts an eight digit Line ID number at the beginning of each record. Line ID numbers are not stored, but are added when data is released. Each time data is polled, the first line number will always be 00000001. This command will only effect the port that invoked the command.

**Command Options:**

- ^B59,1** Disable Line ID Option (**Default**)
- ^B59,2** Enable Line ID Option

**Corresponding Menu Function:** Control Port Configuration Menus, Item 24.

**^B60 Define Console/Modem Port Bits & Parity**

**(Supervisor Mode Only)** Selects bits and parity parameters for the Console Port or Modem Port. Command ^B60 uses the following format:

**^B60 [ ,port ] [ ,set ] [Enter]**

Where:

- ,port** **Port:** If this argument is omitted, ^B60 will set bits and parity for the Console Port. Offers the following options:
  - ,C** Set Bits/Parity for Console Port
  - ,M** Set Bits/Parity for Modem Port
- ,set** **Bits/Parity Setting:** Sets Bits and Parity for the selected port. Offers the following options:
  - ,1** 7 Bits, Even Parity
  - ,2** 7 Bits, Odd Parity
  - ,3** 8 Bits, No Parity (**Default**)
  - ,4** 7 Bits, No Parity

**Note:** This command is included to maintain compatibility with PollCat II units. If compatibility is not an issue, use the Port Configuration Menus, or command ^B90 (Modem Port Parameters) or ^B91 (Console Port Parameters.)

**Corresponding Menu Function:** Modem Port Configuration Menu, Item 2.

## **^B61 Define PBX Port Bits & Parity**

---

**(Supervisor Mode Only)** Selects bits and parity settings for PBX Port A, PBX Port B, and the AUX Port, using the following format:

**^B61 [ ,port] [ ,set] [Enter]**

Where:

- ,port**     **Port:** If this argument is omitted, ^B60 will set bits and parity for the PBX Port A. Offers the following options:
- ,A**       Set Bits/Parity for PBX Port A
  - ,B**       Set Bits/Parity for PBX Port B  
(not available on NLJ-VIP)
  - ,X**       Set Bits/Parity for the AUX Port  
(not available on NLJ-VIP)
- ,set**     **Bits/Parity Setting:** Sets Bits and Parity for the selected port. Offers the following options:
- ,1**       7 Bits, Even Parity (**Default**)
  - ,2**       7 Bits, Odd Parity
  - ,3**       8 Bits, No Parity
  - ,4**       7 Bits, No Parity

**Note:** This command is included to maintain compatibility with PollCat II units. If compatibility is not an issue, use the Port Configuration Menus, or command ^B92 (PBX Port A,) ^B93 (PBX Port B,) or ^B96 (AUX Port.)

**Corresponding Menu Function:** Input Port Configuration Menus, Item 2.

## **^B62 Select Output Format**

---

Selects the format that will be used when data is released to the polling device. Note that this command will only effect the port that invoked the command.

### **Command Options:**

- ^B62 ,1**   Release Data in ASCII Format (**Default**)
- ^B62 ,2**   Release Data in ASCII Format
- ^B62 ,3**   Release Data in Binary Block Format
- ^B62 ,4**   Release Data in Xmodem Format
- ^B62 ,5**   Release Data in Zmodem Format

**Corresponding Menu Function:** Port Configuration Menus, Item 21.

---

**^B64 Enable / Disable Wrap Around Mode**

---

**(Supervisor Mode Only)** When the VIP's internal memory is full, the wrap around mode allows new data to be written over older data. This allows the VIP to continually recycle its memory.

**Command Options:**

- ^B64,1** Disable Wrap Around Mode (**Default**)
- ^B64,2** Enable Wrap Around Mode

**Corresponding Menu Function:** System Parameters Menu, Item 5.

---

**^B65 Select Alarm Filters**

---

**(Supervisor Mode Only)** Determines which user-defined Alarm Filter will be used for PBX Port A, PBX Port B, and the AUX Port. This command uses the following format:

**^B65 [ ,port ] [ ,filter ] [Enter]**

Where:

- ,port** Input Port: If this argument is omitted, ^B56 will assign the selected filter to PBX Port A. Offers the following options:
  - ,A** PBX Port A (Default)
  - ,B** PBX Port B (not available on NLJ-VIP)
  - ,X** AUX Port (not available on NLJ-VIP)
  - ,I** PBX IP Port
- ,filter** Alarm Filter: Selects or disables the Alarm Filter. The following options are available:
  - ,1** Disable Alarm Filter at Selected Port (**Default**)
  - ,2** Assign Alarm Filter #1 to Selected Port
  - ,3** Assign Alarm Filter #2 to Selected Port

**Corresponding Menu Function:** Port Configuration Menus , Item 15.

### **^B66 Enable / Disable Time / Date Stamp**

---

**(Supervisor Mode Only)** Enables the time/date stamp option for each input port. The time/date stamp will be inserted at the beginning of each record, prior to storage in the VIP's memory. This command uses the following format:

**^B66[,port][,action] [Enter]**

Where:

- ,port** Input Port: If this argument is omitted, ^B66 will enable or disable the time/date stamp for PBX Port A. Offers the following options:
- ,A** PBX Port A (**Default**)
  - ,B** PBX Port B (not available on NLJ-VIP)
  - ,X** AUX Port (not available on NLJ-VIP)
  - ,I** PBX IP Port
- ,action** Enable / Disable: Offers the following options:
- ,1** Disable Time/Date Stamp (**Default**)
  - ,2** Enable Time/Date Stamp
  - ,3** Enable Long Format Time/Date Stamp

**Corresponding Menu Function:** Port Configuration Menus, Item 11.

### **^B67 Set Auto Delete Option**

---

**(Supervisor Mode Only)** When data is released to the polling device, the Auto Delete option can automatically erase each data block from the VIP memory after reception is acknowledged. Note that this command will only effect the port that invoked the command.

**Command Options:**

- ^B67,1** Disable Auto Delete Option (**Default**)
- ^B67,2** Enable Auto Delete Option

**Note:** Before enabling the Auto Delete Option, please refer to the cautions listed in Section 16.6 of this User's Guide.

**Corresponding Menu Function:** Port Configuration Menus, Item 26.

### **^B68 Set Command Echo**

---

Enables / Disables the command echo function. When enabled, commands sent to the VIP will be echoed back to the polling device. Note that this command will only effect the port that invokes the command.

**Command Options:**

- ^B68,1** Disable Command Echo
- ^B68,2** Enable Command Echo (**Default**)

**Corresponding Menu Function:** Port Configuration Menus, Item 11.

## ^B70 Enable/Disable Immediate Callout and 80% Full Alarm

**(Supervisor Mode Only)** Enables and configures the Immediate Callout and 80% Full Alarm. When Immediate Callout is enabled, the VIP will dial a user- defined Callout Number, approximately 5 seconds after a disconnect or loss of carrier. Note that the Immediate Callout feature must be enabled prior to each use.

When the 80% Full Alarm is enabled, the VIP can perform any of the standard Alarm Actions when internal memory becomes 80% full. For more information, please refer to Section 11.

### Command Options:

<b>^B70</b>	Disable Immediate Callout and 80% Full Alarm
<b>^B70 , I , 1 , 1</b>	Enable Immediate Callout
<b>^B70 , I , 1 , 2</b>	Disable Immediate Callout
<b>^B70 , I , 2 , n</b>	Define Immediate Callout Number (Where <b>n</b> = Desired Immediate Callout Number.)
<b>^B70 , I , 2 , [Space]</b>	Clear Immediate Callout Number.
<b>^B70 , % , 1 , 1</b>	Enable 80% Full Alarm.
<b>^B70 , % , 1 , 2</b>	Disable 80% Full Alarm.
<b>^B70 , % , 2 , x</b>	Define notification action; Where <b>x</b> is the desired action and <b>1</b> = None, <b>2</b> = Callout, <b>3</b> = Alphanumeric Page, <b>4</b> = Numeric Page, <b>5</b> = SNMP Trap, <b>6</b> = Output Contact Action, and <b>7</b> = Console Action.
<b>^B70 , % , 3 , n</b>	Define number for 80% Full Callout or Page (Where <b>n</b> is the desired phone number.)
<b>^B70 , % , 3 , [Space]</b>	Clear 80% Full callout number.
<b>^B70 , % , 4 , PagerID</b>	Define Pager ID Number 1 for 80% Full Alarm.
<b>^B70 , % , 4 , [Space]</b>	Clear Pager ID Number 1.
<b>^B70 , % , 5 , PagerID</b>	Define Pager ID Number 2 for 80% Full Alarm.
<b>^B70 , % , 5 , [Space]</b>	Clear Pager ID Number 2.
<b>^B70 , % , 6 , PagerID</b>	Define Pager ID Number 3 for 80% Full Alarm.
<b>^B70 , % , 6 , [Space]</b>	Clear Pager ID Number 3.
<b>^B70 , % , 7 , message</b>	Define 80% Full Alarm Message. This message can be sent when the alarm generates a Callout, Alphanumeric Page, SNMP Trap or Console Action.
<b>^B70 , % , 7 , [Space]</b>	Clear 80% Full Alarm Message.
<b>^B70 , % , 8 , 1</b>	Enable Auto Execute Function for 80% Full Alarm.
<b>^B70 , % , 8 , 2</b>	Disable Auto Execute Function for 80% Full Alarm.
<b>^B70 , % , 9 , cmds</b>	Define the Auto Execute Command String for this alarm. Where <b>cmds</b> is a series of ^Bxx commands, with each command separated by a backslash character followed by a forward slash (\/).
<b>^B70 , % , 9 , [Space]</b>	Clear Auto Execute Command String.

**Corresponding Menu Function:** Immediate Callout; Modem Port Configuration Menu, Item 34. 80% Full Alarm; Alarm Configuration Menu, Item 5.

### **^B71 Enable/Disable DLE Stuffing Option**

---

**(Binary Block Mode Only)** DLE Stuffing allows literal 8 bit characters to be inserted into a string of binary data. After data is released, the 8 bit characters can be retrieved and read. Note that this command will only effect the port that invoked the command.

#### **Command Options:**

- ^B71,1** Disable DLE Stuffing Option (**Default**)
- ^B71,2** Enable DLE Stuffing Option

**Corresponding Menu Function:** Port Configuration Menus, Item 29.

### **^B72 Display Time, Day, Date**

---

Displays clock and calendar settings. Type **^B72** and press **[Enter]**.

### **^B73 Send Binary Information Block**

---

Sends an information block in binary format. This block includes the Site ID Message, current time and date, Reason for Action, Partition Record Count, and Percent Full. Information is sent in binary block format, regardless of the current output mode setting. Type **^B73 [Enter]**.

### **^B74 Save / Recall Parameters**

---

**(Supervisor Mode Only)** Saves newly defined VIP parameters, or restores previously defined parameters from memory. For more information, please refer to Section 15.1.

#### **Command Options:**

- ^B74** Save Current Parameters to Flash Memory
- ^B74,1** Save Current Parameters to Flash Memory
- ^B74,2** Recall Parameters from Flash Memory
- ,y** (Optional Argument) Suppress "Sure?" prompt

**Corresponding Menu Function:** Main Menu, Item 7.

---

**^B75 Enable / Disable "Sure?" Prompt**

---

**(Supervisor Mode Only)** When certain commands are invoked, the "Sure?" prompt is displayed to allow the user to verify the command should be executed. When enabled, a prompt will be displayed for ^B25 (Clear Partition), ^B39 (Clear All Records), ^B50 (Reset Options to Defaults), ^B74 (Save / Recall Parameters), ^B76 (Release Remote Partition), and others. Note that this command will only effect the port that invoked the command.

**Command Options:**

- ^B75,1** Disable "Sure?" Prompt
- ^B75,2** Enable "Sure?" Prompt (**Default**)

**Corresponding Menu Function:** Port Configuration Menus, Item 13.

---

**^B76 Release Remote Partition**

---

**(Supervisor Mode Only)** Releases the current memory partition for the specified port.

**Command Options:**

- ^B76** Release Console Port Partition
- ^B76,c** Release Console Port Partition
- ^B76,m** Release Modem Port Partition
- ^B76,T1** Release Partition for Telnet Port 1
- ^B76,T2** Release Partition for Telnet Port 2
- ^B76,T3** Release Partition for Telnet Port 3
- ^B76,F** Release FTP Server Partition
- ,y** (Optional Argument) Suppress "Sure?" Prompt

**Corresponding Menu Function:** Buffer Functions Menu, Item 8.

---

**^B77 Define Modem Initialization Message**

---

**(Supervisor Mode Only)** Defines the VIP's modem initialization command string (AT Command String). The default string is "ATE0M0Q1&C1&D2S0=1". To redefine the initialization string, type **^B77,init [Enter]**, where "init" is the desired command string.

**Corresponding Menu Function:** Modem Port Config. Menu, Item 6.

### **^B78 Display Modem Message**

---

Displays the Modem Reset Message (AT Command String), Initialization String, and Hang-Up String. Type **^B78** and press **[Enter]**.

**Corresponding Menu Function:** Status Displays, item 25

### **^B79 Define / Display Passwords**

---

(Supervisor Mode Only) Defines and/or displays command mode passwords. The default Supervisor password is "SUPER", the default User 1 password is "SMDR", and the default User 2 password is not defined.

#### **Command Options:**

- ^B79** Displays Supervisor Level Password
- ^B79,pass** Defines "**pass**" as the Supervisor Level Password
- ^B79,1,pass** Defines "**pass**" as the Supervisor Level Password
- ^B79,2** Displays the User 1 Password
- ^B79,2,pass** Defines "**pass**" as the User 1 Password
- ^B79,3** Displays the User 2 Password
- ^B79,3,pass** Defines "**pass**" as the User 2 Password

**Corresponding Menu Function:** System Parameters Menu, Items 1, 2, and 3.

### **^B83 Display Alarm Clue Summary**

---

Displays a table which shows Clue Names, Threshold Counts, Actual Counts, and Alarm Status. To display Alarm Clue counter status, type **^B83** and press **[Enter]**.

#### **Command Options:**

- ^B83,1** Display Clue Summary for Alarm Filter 1.
- ^B83,2** Display Clue Summary for Alarm Filter 2.

**Corresponding Menu Function:** Status Displays, Items 31 through 38.

### **^B84 Clear Alarm Condition**

---

Clears the Alarm Condition and cancels Alarm Actions, without resetting the Alarm Clue Counters or turning off the ALM LED.

#### **Command Options:**

- ^B84** Clear Alarm Condition
- ^B84,y** Suppress "Sure?" Prompt, Clear Alarm Condition.

**Corresponding Menu Function:** System Functions, Item 4.



## **^B86 Reset Alarm Clue Counters**

---

Resets counters for specified Alarm Clue to zero. To clear an alarm condition, please use Command ^B84.

### **Command Options:**

- ^B86, "clue"**     Reset Counter for **clue** only.
- ^B86, \*, A1**     Reset All Counters for Alarm Filter 1.
- ^B86, \*, A2**     Reset All Counters for Alarm Filter 2.
- ^B86, \***         Reset all counters for Alarm Filters 1 and 2.

**Note:** If both Alarm Filters include a clue with the same name, command ^B86 must specify the desired alarm filter.

**Corresponding Menu Function:** System Functions, Item 5

## **^B89 Test Alpha Pager**

---

To test an alphanumeric pager, type **^B89, 1 [Enter]**, and then exit command mode. After approximately two minutes, the pager should receive the "Pager Test" message. In order for this command to function, the Pager Phone Number and Pager ID Number must first be defined via the Pager Test Submenu.

**Corresponding Menu Function:** System Diagnostics Menu, Item 3.

## **^B90 Reset Modem Port / Define Modem Port Communication Parameters**

---

**(Supervisor Mode Only)** This command can be used to reset the VIP's internal modem or redefine modem communication parameters.

**Reset Modem:** To reset the modem, use the following format:

**^B90**      Reset Modem

**^B90 , Y**    Reset Modem, Suppress "Sure?" Prompt.

**Configure Modem Port:** To define modem communication parameters, use the following format:

**^B90 , baud , parity , data , stop [Enter]**

Where:

**baud**      **Baud Rate:** Any standard rate from 300 bps to 115.2 Kbps. It is only necessary to enter the first two characters of the baud rate. If an asterisk is entered in this field, the port will be set to the default modem port baud rate (57.6 Kbps).

**parity**    **Parity Bits:** None (**n**), Odd (**o**), or Even (**e**)

**data**      **Data Bits:** 7 or 8

**stop**      **Stop Bits:** 1 or 2

**Corresponding Menu Function:** Modem Port Configuration Menu.

## **^B91 Console Port Communication Parameters**

---

**(Supervisor Mode Only)** Defines the baud rate, parity, data bits, and stop bits for the Console Port. This command uses the following format:

**^B91 , baud , parity , data , stop [Enter]**

Where:

**baud**      **Baud Rate:** Any standard rate from 300 bps to 115.2 Kbps. Note that it is only necessary to enter the first two characters of the baud rate. If an asterisk is entered in this field, the port will be set at the default rate specified by set-up switches 1, 2, and 3.

**parity**    **Parity Bits:** None (**n**), Odd (**o**), or Even (**e**)

**data**      **Data Bits:** 7 or 8

**stop**      **Stop Bits:** 1 or 2

**Corresponding Menu Function:** Console Port Configuration Menu.

---

**^B92 PBX Port A Communication Parameters**

---

**(Supervisor Mode Only)** Defines the baud rate, parity, data bits, and stop bits for PBX Port A. This command uses the following format:

**^B92,baud,parity,data,stop [Enter]**

Where:

<b>baud</b>	<b>Baud Rate:</b> Any standard rate from 300 bps to 115.2 Kbps. Note that it is only necessary to enter the first two characters of the baud rate. If an asterisk is entered in this field, the port will be set to the default rate specified by Set-Up switches 4 and 5.
<b>parity</b>	<b>Parity Bits:</b> None (n), Odd (o), or Even (e)
<b>data</b>	<b>Data Bits:</b> 7 or 8
<b>stop</b>	<b>Stop Bits:</b> 1 or 2

**Corresponding Menu Function:** PBX Port A Configuration Menu.

---

**^B93 PBX Port B Communication Parameters**

---

**(Supervisor Mode Only)** Defines the baud rate, parity, data bits, and stop bits for PBX Port B. This command uses the following format:

**^B93,baud,parity,data,stop [Enter]**

Where:

<b>baud</b>	<b>Baud Rate:</b> Any standard rate from 300 bps to 115.2 Kbps. Note that it is only necessary to enter the first two characters of the baud rate. If an asterisk is entered in this field, the port will be set to the default rate specified by Set-Up switches 4 and 5.
<b>parity</b>	<b>Parity Bits:</b> None (n), Odd (o), or Even (e)
<b>data</b>	<b>Data Bits:</b> 7 or 8
<b>stop</b>	<b>Stop Bits:</b> 1 or 2

**Corresponding Menu Function:** PBX Port B Configuration Menu.

## **^B94 Enter Monitor Mode**

---

**(Supervisor Mode Only)** Allows direct communication with the PBX. In Monitor Mode, data can be received directly from the PBX in order to check reception. Commands can also be sent directly to the PBX. To exit Monitor Mode, type **^B30** and press **[Enter]**.

### **Command Options:**

- ^B94 ,A** Monitor PBX Port A
- ^B94 ,B** Monitor PBX Port B (not available on NLJ-VIP)
- ^B94 ,X** Monitor AUX Port (not available on NLJ-VIP)
- ^B94 ,I** Monitor PBX IP Port
- ^B94 ,C** Monitor Console Port
- ^B94 ,M** Monitor Modem Port

**Corresponding Menu Function:** System Functions, Item 3.

## **^B95 Display Program Version**

---

Displays the version number of the VIP Firmware. Type **^B95** and press **[Enter]**.

## **^B96 AUX Port Communication Parameters**

---

**(Supervisor Mode Only)** Defines baud rate, parity, data bits, and stop bits for AUX Port. This command uses the following format:

**^B96,baud,parity,data,stop [Enter]**

Where:

- baud**     **Baud Rate:** Can be any standard rate from 300 bps to 115.2 Kbps. Note that it is only necessary to enter the first two characters of the baud rate. If an asterisk is entered in this field, the port will be set to the default rate specified by Set-Up switches 4 and 5.
- parity**   **Parity Bits:** Can be None (**n**), Odd (**o**), or Even (**e**)
- data**     **Data Bits:** Can be 7 or 8
- stop**     **Stop Bits:** Can be 1 or 2

**Note:** NLJ-VIP units do not include the AUX port, and therefore, this command will not function on NLJ-VIP units.

**Corresponding Menu Function:** AUX Port Configuration Menu.

---

## ^B97 Define / Display Network Parameters

---

**(Supervisor Mode Only)** Displays and/or Defines network parameters, including the IP Address, Subnet Mask, and Gateway Address.

### Command Options:

<b>^B97</b>	Display Network Parameters
<b>^B97, 1, IPADDR</b>	Define IP Address; Where <b>IPADDR</b> is the desired IP Address.
<b>^B97, 1, [Space]</b>	Clear IP Address
<b>^B97, 2, SUBNET</b>	Define Subnet Mask Address; Where <b>SUBNET</b> is the desired address.
<b>^B97, 2, [Space]</b>	Clear Subnet Mask
<b>^B97, 3, GATEWAY</b>	Define Gateway Address; where <b>GATEWAY</b> is the desired address.
<b>^B97, 3, [Space]</b>	Clear Gateway Address
<b>^B97, 4, SNMP1</b>	Define SNMP Manager 1; where <b>SNMP1</b> is the desired SNMP Manager.
<b>^B97, 4, [Space]</b>	Clear SNMP Manager 1.
<b>^B97, 5, SNMP2</b>	Define SNMP Manager 2; where <b>SNMP2</b> is the desired SNMP Manager.
<b>^B97, 5, [Space]</b>	Clear SNMP Manager 2.
<b>^B97, 6, SNMPC</b>	Define SNMP Community; where <b>SNMPC</b> is the desired SNMP Community.
<b>^B97, 6, [Space]</b>	Clear SNMP Community.

**Corresponding Menu Function:** Display Parameters; Status Displays, Item 26. Define Parameters; Port Configuration, Item 6.

---

## ^B98 Reset Network Port

---

**(Supervisor Mode Only)** Reinitializes the Network Port. Type **^B98 [Enter]**. If the "Sure" option is enabled, a prompt will be displayed before this command is completed. Type **Y** to proceed or **N** to abort, and then press **[Enter]**.

### Command Options:

<b>^B98</b>	Display "Sure" Prompt (If Enabled), Reset Network Port
<b>^B98, Y</b>	Suppress "Sure" Prompt, Reset Network Port

**Corresponding Menu Function:** Network Port Configuration Menu, Item 7.

## **^B99 Save Current Parameters**

---

**(Supervisor Mode Only)** Saves currently defined VIP parameters to an ASCII text file on your polling device. In the event of corruption or erasure, the saved parameters can be downloaded to the unit in order to restore the previous configuration.

Note that when this command is invoked, the command echo must be disabled at your command port. If the command echo is *not* disabled, the ^B99 command will be included in the saved parameters file, and will cause problems when the file is later uploaded to the VIP unit.

There are two ways to suppress the command echo; via the Port Configuration Menu, or by entering the ^A character in place of the ^B character. When the ^A character is substituted for the ^B character (e.g. ^A99), the command echo will be temporarily suppressed, regardless of the current command echo setting.

Please refer to Section 15.2.2 for more information.

**Corresponding Menu Function:** Main Menu, Item 7.

# A. Specifications

---

## A.1. NetLink-VIP Specifications

---

**Storage Capacity:** Using dual compression, approximate storage capacity is as follows. Capacity may vary with different PBX formats.

Memory Size	Approximate Call Record Capacity
512K	16,000
4M	125,000
8M	250,000
16M	500,000
32M	1,000,000
64M	2,000,000

**Memory:** Flash Memory

**Coding:** 7/8 data bits, even/odd/no parity bit, 1,2 stop bits.

**Input Port Baud Rates (PBX A, PBX B, AUX Port):** All standard rates from 300 bps to 115.2 Kbps.

**Modem Port Baud Rates:** All standard rates from 300 bps to 115.2 Kbps.

**Console Port Baud Rates:** All standard rates from 300 bps to 115.2 Kbps.

**Connectors:**

**Network Port:** 10Base-T

**Modem Port:**

**Line:** RJ11 Jack to Telephone Line.

**Phone:** Not Used.

**Console Port:** RS-232 DCE, DB25 female (modem style).

**AUX Port, PBX Ports A & B:** RS-232 DTE, DB9 male. XON/XOFF or RTS/CTS flow control. All parameters programmable.

**LED Indicators:** ON, RDY, ALM, >0%, >25, >50, >75, FULL, OH, DCD, CP, AUX, A, B

**Size:** 3.45" x 14.75" x 7.75" (H x W x D).

**Weight:** 7.4 lbs. total shipping weight.

**Power:** 115/230 VAC, 50/60 Hz, 12 watts, Auto-sensing voltage.

**Operating Temperature Range:** 50°F to 104°F (10°C to 40°C).

**Humidity:** 20% to 80% RH.

**Fuse:** 250 Volts, 0.125 Amps, Slow Blow.

## **A.2. NLJ-VIP (NetLink Jr.-VIP) Specifications**

---

**Storage Capacity:** Using dual compression, approximate storage capacity is 10,000 to 16,000 records.

**Memory:** Flash Memory. 512K for Data Storage.

**Coding:** 7/8 data bits, even/odd/no parity bit, 1,2 stop bits.

**Input Port Baud Rates:** All standard rates from 300 bps to 115.2 Kbps.

**Modem Port Baud Rates:** All standard rates from 300 bps to 115.2 Kbps.

**Console Port Baud Rates:** All standard rates from 300 bps to 115.2 Kbps.

### **Connectors:**

**Network Port:** 10Base-T

#### **Modem Port:**

**Line:** RJ11 Jack to Telephone Line.

**Phone:** Not Used.

**Console Port:** RS-232 DCE, DB25 female (modem style).

**PBX Input Port:** RS-232 DTE, DB9 male. XON/XOFF or RTS/CTS flow control. All parameters programmable.

**LED Indicators:** ON, RDY, ALM, >0%, >25, >50, >75, FULL, OH, DCD, CP, A

**Size:** 3.0" x 11.0" x 7.5" (H x W x D).

**Weight:** 7 lbs. total shipping weight.

**Power:** 115/230 VAC, 50/60 Hz, 12 watts, Auto-sensing voltage.

**Operating Temperature Range:** 50°F to 104°F (10°C to 40°C).

**Humidity:** 20% to 80% RH.

**Fuse:** 250 Volts, 0.125 Amps, Slow Blow.



## B. Description of System Interfaces

### B.1. Input Ports (PBX A, PBX B, AUX) (DB9 Male; DTE)

**Note:** NLJ-VIP units do not include PBX Port B or the AUX Port.

Pin	Signal
1	Data Carrier Detect (In)
2	Receive Data (In)
3	Transmit Data (Out)
4	Data Terminal Ready (Out)
5	Signal Ground
6	Not Connected
7	Ready to Send (Out)
8	Clear to Send (In)
9	Not Connected

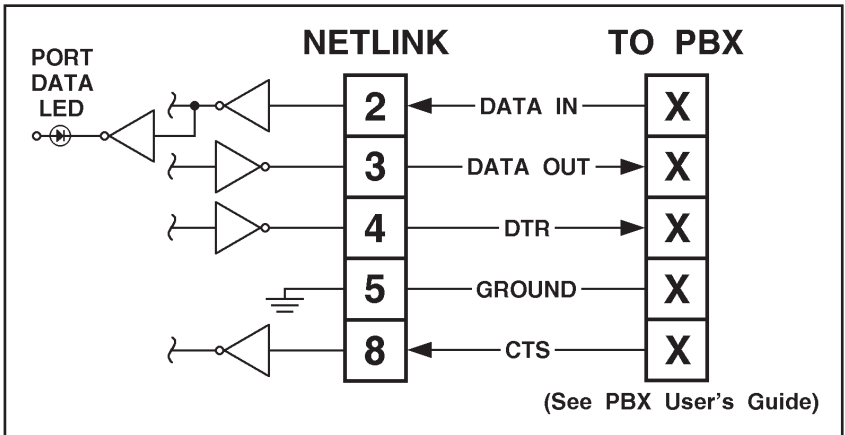

Figure B.1: Data Input Ports (PBX A, PBX B & AUX)

## B.2. Console Port (DB-25 Female; DCE)

Pin	Signal
2	Receive Data (In)
3	Transmit Data (Out)
4	Request to Send (In)
5	Clear to Send (Out)
6	Data Set Ready (Out)
7	Signal Ground
8	Data Carrier Detect (Out)
20	Data Terminal Ready (In)

### B.2.1. Console Port to 25-Pin PC

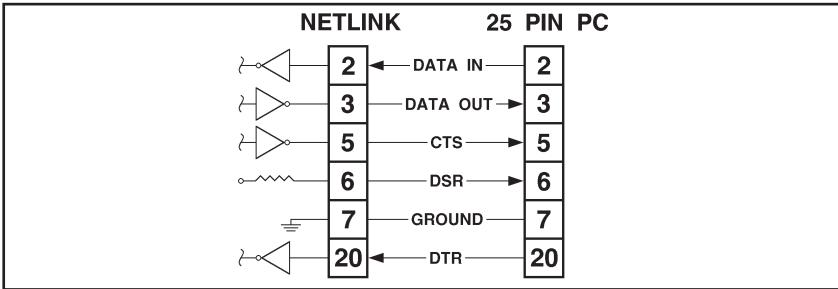

Figure B.2: Console Port to 25-Pin PC

### B.2.2. Console Port to 9-Pin PC

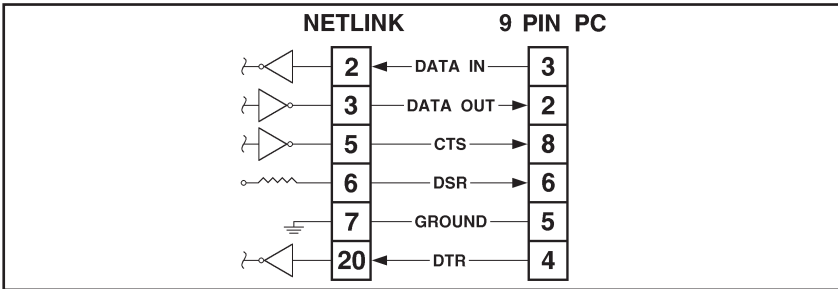

Figure B.3: Console Port to 9 Pin PC

## **C. Supervisor Functions and User Functions**

---

In order to restrict access to sensitive commands, the VIP offers two separate operating modes; Supervisor Mode and User Mode.

Supervisor Mode allows access to all command functions, including those used to setup and configure the VIP unit. User Mode allows limited access to command functions; users are able to invoke commands to review status and read data, but are not allowed to change system parameters.

### **C.1. Security Mode at Start Up**

---

When the password feature is enabled, the VIP will display a prompt each time the Command Mode is accessed. If the Supervisor level password is entered at this prompt, the unit will start up in Supervisor Mode. If a User level password is entered, the VIP will start up in User Mode.

The VIP provides one Supervisor password and two User passwords. The default Supervisor Password is "SUPER". The default User 1 Password is "SMDR", the default User 2 Password is not defined.

### **C.2. Dialback Security**

---

The Dialback Security feature provides an additional level of security for modem access to command mode functions. When this feature is configured and enabled (Sw6 = UP), the VIP will display a password prompt when contacted via modem. If the caller enters a valid password, the VIP will hang up, and then dial the user-defined dialback number for the password entered.

After contacting the dialback number, the password prompt will again be displayed. If the Supervisor Password is entered at this point, the VIP will start-up in Supervisor Mode; allowing access to all menu and command functions. If a User Password is entered at the dialback prompt, the VIP will start-up in User Mode; allowing limited access to command functions.

### C.3. Supervisor Mode and User Mode Functions

The table below summarizes the functions that are available in each of the two security modes.

Menu Function	Supervisor Mode	User Mode
1. Status Displays	Yes	Yes
2. Buffer Functions	Yes	User Mode allows access to all Buffer Functions except: 8. "Release Remote Partition"
3. System Functions	Yes	User Mode allows access to all System Functions except: 2. "Passthrough Mode" 3. "Monitor Mode" 6. "Download Parameters" 7. "Audit Trail Functions" 8. "Upload Firmware"
4. System Diagnostics	Yes	Yes
5. ^Bxx Command Help	Yes	Yes
6. Recall Parameters	Yes	No
7. Save Parameters	Yes	No
8. Exit Command Mode	Yes	Yes
21. Default Parameters	Yes	No
22. Port Configuration	Yes	No
23. System Parameters	Yes	No
24. Scheduled Actions	Yes	No
25. Alarm Configuration	Yes	No
26. Data Filter Configuration	Yes	No
27. FTP Push Configuration	Yes	No
28. FTP Server Configuration	Yes	No

## D. Alarm Clue Definition Tips

---

This section describes techniques that can be used to avoid common problems that are often encountered when defining Alarm Clues.

To effectively detect Toll Fraud, Alarm Clues must produce an accurate count of calls that match the characteristics of a suspect phone call. Careful planning will allow you to create clues that count suspect calls, and ignore calls you don't need.

### D.1. Headers, Banners, and Other "Non-Data"

---

When you examine data produced by the PBX, you will often discover that in addition to call records, the PBX also creates records that do not contain call data. In order to avoid counting this "non-data", clues must be carefully defined to exclude headers and other items.

In the example below, several call records are shown along with a header. The PBX might generate this header after every 100 calls to identify the record fields. This is helpful when defining the format, but can also be a nuisance when counting calls.

```
+-----+-----+-----+-----+-----+
TIME  EXT  DUR   NO. DIALED      COST
+-----+-----+-----+-----+-----+
|09:15|074|01:25|19495869950    |00.35|
|09:17|112|00:45|18008547226    |00.00|
|09:18|085|00:20|8531212      |00.10|
|09:20|124|02:25|19495839514    |00.55|
|09:18|091|00:25|411          |00.10|
```

#### D.1.1. The Comparative Operators

When the comparative operators (>, <, >=, and <=) are used, care must be taken to limit the scope of the comparison.

When the VIP compares information in a call record with values indicated in the clue definition, it performs an "ASCII comparison". All ASCII characters are compared, not just numbers. Each ASCII character, (including letters and symbols) has a numerical value. Letters of the alphabet have a higher value than numbers, and symbols have a lower value.

Although call records may always have a numerical value in a specific field, "non-data" such as headers and summaries, might have letters or symbols in that field. When creating an Alarm Clue that includes the comparative operators, the VIP must be prevented from counting symbols and alphabetic characters as numerical values.

For example, if the variable "B" represents call duration and you wish to check for calls lasting longer than 15 minutes, the definition would include the phrase "B>15:00". Unfortunately, this would also count headers that have alphabetic text in the call duration field.

If your Alarm Clues are also counting non-data, the techniques described in the following sections can be used to obtain a more reliable count.

#### D.1.1.1. Limit Comparisons

When comparative operators are used, values can be defined as a range between two numbers, rather than an open ended range. In other words, if a "Greater Than" operator is used, it can be matched with a "Less Than" operator in order to limit the scope of the comparison.

**Example:** Define a clue that counts calls placed after 5:00 pm (17:00). Assume that the variable "A" represents the time the call was placed. The most direct way to define match parameters is as follows:

**A>17:00**

However, when the clue is defined this way, headers and summaries with alphabetic characters in the "A" field will also appear in the count. To prevent the clue from counting "non-data", the "A" variable can be defined as a range as shown below:

**A>17:00\*A<99:99**

This definition would prevent the clue from including "non-data" records that have alphabetic characters in the "A" field, since alphabetic characters would have a value higher than 99:99.

#### D.1.1.2. Exclude Non-Data Characteristics

Another way to eliminate non-data from the count is to define the clue in a manner that excludes the characteristics of headers and call accounting summaries.

If you examine the data generated by the PBX, there is usually a factor which differentiates non-data from call records. In some cases, call records will always begin with a specific character, and non-data will omit this character. In other cases, non-data will have a specific text item in a field, where call records will have a numerical value. Once you have determined a factor that differentiates between non-data and call records, it is relatively simple to define clues that exclude the non-data.

**Example:** Define a clue that counts calls lasting three minutes or longer. Assume the variable "B" represents the call duration. The most direct way to define this clue is as follows:

**B>=03:00**

---

However, when the clue is defined this way, headers and summaries with alphabetic characters in the "B" field would also appear in the count.

In order to exclude undesired records, assume you have determined that call records always begin with the character "|" (vertical bar). In order to use this knowledge in the clue definition, you would first re-define the format to include the variable "L" to represent the first character in the record, and then re-define match parameters as follows:

**B>=03:00\*L=|**

This definition would exclude headers and summaries by only counting records that begin with the "|" (vertical bar) character.

### **D.1.2. Exact Match with PBX Call Record Format**

Both the Alarm Filter Format and the Alarm Clue definition must exactly match the data storage format used by the PBX.

When your PBX stores data items such as the number dialed or time values, the punctuation and exact characters used will differ from the formats shown in the examples.

Prior to defining the Alarm Filter Format and Alarm Clues, it is recommended to carefully examine a number of records. Check each data item to determine the exact format used by the PBX. Later, when the Alarm Filter Format and Alarm Clues are defined, your definition must reflect the format used by the PBX.

## **D.2. Programming Support**

---

If you have difficulty defining formats or clues, you can call the service department at Western Telematic, Inc. at (949) 586-9950 or 1 (800) 854-7226, between 8:00 am and 5:00 am, Pacific Time. Any VIP unit configured to allow remote access can be contacted via modem and programmed by WTI service personnel.

Before calling, make certain your VIP unit has been allowed to store a substantial number of call records, representative of the type produced by the PBX. Please be prepared to give a description of the clues you need to define.

## **E. Customer Service**

---

Customer Service hours are from 8:00 am to 5:00 pm, Pacific Time, Monday through Friday. When calling, please be prepared to give provide the serial number of the unit, as well as a description of the problem. If the unit should need to be returned for factory repair, it must be accompanied by a Return Authorization Number issued by WTI Customer Service.

**WTI Customer Service**

5 Sterling

Irvine, California 92618-2517

**Local Phone:** (949) 586-9950

**Toll Free Service Line:** 1-888-280-7227

**Service Fax:** (949) 457-8138

**E-mail:** [service@wti.com](mailto:service@wti.com)



## G. ^ Bxx Command Summary

---

Cmd.	Description / Options
^B00	Set/Reset Memory Partition ^B00[,type][,source] or ^B00,R Where: [,type] <b>Data Type:</b> Offers the following options: ,A1     Include Records that Match Alarm Filter 1 (or ,A     Include Records that Match Alarm Filter 1 ,A2     Include Records that Match Alarm Filter 2 ,ALM    Include All Alarm Records from both Filters ,STD    Include Non-Alarm (Standard) Records (or ,D     Include Non-Alarm (Standard) Records [,source] <b>Source Port:</b> Offers the following options: ,PA     Include Records Received via PBX Port A ,PB     Include Records Received via PBX Port B (Not Available on NLJ-VIP Models.) ,PX     Include Records Received via the AUX Port (Not Available on NLJ-VIP Models.) ,PI     Include Records Received via PBX IP Port. ,R <b>Release Current Partition:</b> This argument cannot be combined with the [,type] or [,source] arguments.
^B01	Enter Data Read Mode ^B01[,type][,source][@n][,n] Where: [,type] <b>Data Type:</b> Offers the following options: ,A1     Release Records for Alarm Filter 1 Only (or ,A     Release Records for Alarm Filter 1 Only ,A2     Release Records for Alarm Filter 2 Only ,ALM    Release All Alarm Records from both Filters ,STD    Release Non-Alarm Records Only (or ,D     Release Non-Alarm Records Only ,"clue" Release Alarm Records for "clue" Only [,source] <b>Source Port:</b> Offers the following options: ,PA     Release Records Received via PBX Port A. ,PB     Release Records Received via PBX Port B. (Not Available on NLJ-VIP Models.) ,PX     Release Records Received via the AUX Port. (Not Available on NLJ-VIP Models.) ,PI     Release Records Received via PBX IP Port. [@n] <b>Offset:</b> Release records starting with the "nth" record. [,n] <b>Count:</b> Release records in groups of "n".
^B02	Send Next Data
^B03	Display Site ID
^B04	Define Site ID ^B04,site_id Where "site_id" is the desired Site I.D. Message (Up to 32 Characters)

Cmd.	Description / Options																												
^B05	<p>Define End-of-Record Character</p> <p>^B05[,port][,char]</p> <p>Where:</p> <table border="0"> <tr> <td>[,port]</td> <td><b>Input Port:</b> Offers the following options:</td> </tr> <tr> <td>,A</td> <td>PBX Port A</td> </tr> <tr> <td>,B</td> <td>PBX Port B (Not Available on NLJ-VIP Models.)</td> </tr> <tr> <td>,X</td> <td>AUX Port (Not Available on NLJ-VIP Models.)</td> </tr> <tr> <td>,I</td> <td>PBX IP Port</td> </tr> <tr> <td>[,char]</td> <td><b>EOR Character:</b> If a space character is entered, the EOR character for the target port will be cleared.</td> </tr> </table>	[,port]	<b>Input Port:</b> Offers the following options:	,A	PBX Port A	,B	PBX Port B (Not Available on NLJ-VIP Models.)	,X	AUX Port (Not Available on NLJ-VIP Models.)	,I	PBX IP Port	[,char]	<b>EOR Character:</b> If a space character is entered, the EOR character for the target port will be cleared.																
[,port]	<b>Input Port:</b> Offers the following options:																												
,A	PBX Port A																												
,B	PBX Port B (Not Available on NLJ-VIP Models.)																												
,X	AUX Port (Not Available on NLJ-VIP Models.)																												
,I	PBX IP Port																												
[,char]	<b>EOR Character:</b> If a space character is entered, the EOR character for the target port will be cleared.																												
^B06	Re-send Last Data																												
^B07	<p>Continuous Binary Block Read</p> <p>^B07[,type][,source][@n]</p> <p>Where:</p> <table border="0"> <tr> <td>[,type]</td> <td><b>Data Type:</b> Offers the following options:</td> </tr> <tr> <td>,A1</td> <td>Release Records for Alarm Filter 1 Only (or)</td> </tr> <tr> <td>,A</td> <td>Release Records for Alarm Filter 1 Only</td> </tr> <tr> <td>,A2</td> <td>Release Records for Alarm Filter 2 Only</td> </tr> <tr> <td>,ALM</td> <td>Release all Records for both Alarm Filters</td> </tr> <tr> <td>,STD</td> <td>Release Non-Alarm Records Only (or)</td> </tr> <tr> <td>,D</td> <td>Release Non-Alarm Records Only</td> </tr> <tr> <td>,"clue"</td> <td>Release Alarm Records for "clue" Only</td> </tr> <tr> <td>[,source]</td> <td><b>Source Port:</b> Offers the following options:</td> </tr> <tr> <td>,PA</td> <td>Release Records Received via PBX Port A.</td> </tr> <tr> <td>,PB</td> <td>Release Records Received via PBX Port B. (Not Available on NLJ-VIP Models.)</td> </tr> <tr> <td>,PX</td> <td>Release Records Received via the AUX Port. (Not Available on NLJ-VIP Models.)</td> </tr> <tr> <td>,PI</td> <td>Release Records Received via PBX IP Port.</td> </tr> <tr> <td>[@n]</td> <td><b>Offset:</b> Release Records Starting with the "nth" Record.</td> </tr> </table>	[,type]	<b>Data Type:</b> Offers the following options:	,A1	Release Records for Alarm Filter 1 Only (or)	,A	Release Records for Alarm Filter 1 Only	,A2	Release Records for Alarm Filter 2 Only	,ALM	Release all Records for both Alarm Filters	,STD	Release Non-Alarm Records Only (or)	,D	Release Non-Alarm Records Only	,"clue"	Release Alarm Records for "clue" Only	[,source]	<b>Source Port:</b> Offers the following options:	,PA	Release Records Received via PBX Port A.	,PB	Release Records Received via PBX Port B. (Not Available on NLJ-VIP Models.)	,PX	Release Records Received via the AUX Port. (Not Available on NLJ-VIP Models.)	,PI	Release Records Received via PBX IP Port.	[@n]	<b>Offset:</b> Release Records Starting with the "nth" Record.
[,type]	<b>Data Type:</b> Offers the following options:																												
,A1	Release Records for Alarm Filter 1 Only (or)																												
,A	Release Records for Alarm Filter 1 Only																												
,A2	Release Records for Alarm Filter 2 Only																												
,ALM	Release all Records for both Alarm Filters																												
,STD	Release Non-Alarm Records Only (or)																												
,D	Release Non-Alarm Records Only																												
,"clue"	Release Alarm Records for "clue" Only																												
[,source]	<b>Source Port:</b> Offers the following options:																												
,PA	Release Records Received via PBX Port A.																												
,PB	Release Records Received via PBX Port B. (Not Available on NLJ-VIP Models.)																												
,PX	Release Records Received via the AUX Port. (Not Available on NLJ-VIP Models.)																												
,PI	Release Records Received via PBX IP Port.																												
[@n]	<b>Offset:</b> Release Records Starting with the "nth" Record.																												
^B08	Display Current Alarm Record																												
^B09	Exit Command Mode (Disconnect / Hang Up)																												
^B11	<p>Set Time / Date</p> <p>^B11,hh:mm,d,MM/DD\YY</p> <p>Where:</p> <table border="0"> <tr> <td>hh</td> <td>Is the Hour (00 to 23)</td> </tr> <tr> <td>mm</td> <td>Is the Minute (00 to 59)</td> </tr> <tr> <td>d</td> <td>Is the Day of the Week (1=Sun., 2=Mon., 3=Tue., etc.)</td> </tr> <tr> <td>MM</td> <td>Is the Month (01 to 12)</td> </tr> <tr> <td>DD</td> <td>Is the Date (01 to 31)</td> </tr> <tr> <td>YY</td> <td>Is the Year (00 to 99)</td> </tr> </table>	hh	Is the Hour (00 to 23)	mm	Is the Minute (00 to 59)	d	Is the Day of the Week (1=Sun., 2=Mon., 3=Tue., etc.)	MM	Is the Month (01 to 12)	DD	Is the Date (01 to 31)	YY	Is the Year (00 to 99)																
hh	Is the Hour (00 to 23)																												
mm	Is the Minute (00 to 59)																												
d	Is the Day of the Week (1=Sun., 2=Mon., 3=Tue., etc.)																												
MM	Is the Month (01 to 12)																												
DD	Is the Date (01 to 31)																												
YY	Is the Year (00 to 99)																												
^B13	Display Site ID Message / Alarm Message																												
^B16	Display System Status																												
^B17	<p>Display PBX Inactivity Alarm Parameters</p> <p>^B17,1     Display Parameters for Alarm 1</p> <p>^B17,2     Display Parameters for Alarm 2</p>																												
^B18	Display Reason for Action																												

<b>Cmd.</b>	<b>Description / Options</b>
^B19	Display Action Schedule ^B19,1     Display Parameters for Schedule 1 ^B19,2     Display Parameters for Schedule 2
^B20	Display Partition Record Count
^B21	Display Remaining Space
^B22	Display Memory Capacity / PBX Port Baud Rate
^B24	Display DIP Switch Settings
^B25	Erase Partition Data ^B25        Erase Partition Data ^B25,Y     Suppress "Sure" Prompt, Erase Partition Data
^B26	Display Separator Line
^B27	Enter Test Message Mode
^B28	Enter Echo Test Mode
^B29	Enter Pass-Through Mode ^B29,A     Pass-Through to PBX Port A ^B29,B     Pass-Through to PBX Port B (Not Available on NLJ-VIP Models.) ^B29,X     Pass-Through to AUX Port (Not Available on NLJ-VIP Models.) ^B29,I     Pass-Through to PBX IP Port ^B29,C     Pass-Through to Console Port ^B29,M     Pass-Through to Modem Port
^B30	Exit, Return to Command Mode
^B39	Erase All Data ^B39        Clear All Records, Leave Alarm Clue Counters Intact ^B39,Y     Suppress "Sure" Prompt, Clear All Records, Leave Alarm Clue Counters Intact ^B39,2     Clear All Records, and Reset Alarm Clue Counters to Zero ^B39,2,Y   Suppress "Sure" Prompt, Clear All Records, <i>and</i> Reset Alarm Clue Counters to Zero
^B50	Default Parameters ^B50        Reset Options to Default Parameters ^B50,Y     Suppress All Confirmation Prompts, Reset Options to Default Parameters ^B50,2     Reset Options to Defaults, and Erase All Formats, Filter Parameters, and Alarm Clues ^B50,Y,2   Suppress All Confirmation Prompts, Reset Options to Defaults, and Erase All Formats, Filter Parameters, and Alarm Clues

Cmd.	Description / Options
^B51	Store Alarm Data ^B51[,port][,file] Where: [,port] <b>Input Port:</b> Offers the following options: ,A     PBX Port A ,B     PBX Port B (Not Available on NLJ-VIP Models) ,X     AUX Port (Not Available on NLJ-VIP Models) ,I     PBX IP Port [,file] <b>Storage Location:</b> Offers the following options: ,1     Store Alarm Data from this Port in Alarm File ,2     Store Alarm Data from this Port in Standard File ,3     Store Alarm Data from this Port in Both Alarm File and Standard File
^B52	Release / Hold End Data Message ^B52,1     Release End Data Message ^B52,2     Hold End Data Message
^B53	Set Compression Mode ^B53,1     Release Data in Compressed Format ^B53,2     Release Data in Decompressed Format
^B54	Release Data on ^B01 ^B54,1     Release First Group without ^B02 ^B54,2     Wait for Command ^B02
^B55	Strip Non-Printable Codes ^B55[,port][,action] Where: [,port] <b>Input Port:</b> If this argument is omitted, the command will be applied to PBX Port A by default. Options: ,A     PBX Port A ,B     PBX Port B (Not Available on NLJ-VIP Models) ,X     AUX Port (Not Available on NLJ-VIP Models) ,I     PBX IP Port [,action] <b>Store / Strip Codes:</b> Offers the Following Options: ,1     Store Non-Printable Codes ,2     Strip Non-Printable Codes
^B56	Select Data Filters ^B56[,port][,filter] Where: [,port] <b>Input Port:</b> If this argument is omitted, the command will be applied to PBX Port A by default. Options: ,A     PBX Port A ,B     PBX Port B (Not Available on NLJ-VIP Models) ,X     AUX Port (Not Available on NLJ-VIP Models) ,I     PBX IP Port [,filter] <b>Data Filter:</b> Offers the Following Options: ,1     Disable Data Filter at Selected Port ,2     Assign Data Filter #1 to Selected Port ,3     Assign Data Filter #2 to Selected Port

Cmd.	Description / Options
^B57	<p>Enable / Disable XON / XOFF Function ^B57[,port][,action]</p> <p>Where:</p> <p>[,port]     <b>Input Port:</b> If this argument is omitted, the command will be applied to PBX Port A by default. Options:</p> <p>          ,A     PBX Port A</p> <p>          ,B     PBX Port B (Not Available on NLJ-VIP Models)</p> <p>          ,X     AUX Port (Not Available on NLJ-VIP Models)</p> <p>          ,I     PBX IP Port</p> <p>[,action]   <b>Enable / Disable Action:</b> Offers the Following Options:</p> <p>          ,1     Enable XON/XOFF at Selected Port</p> <p>          ,2     Disable XON/XOFF at Selected Port</p>
^B59	<p>Line ID Option</p> <p>^B59,1     Disable Line ID Option</p> <p>^B59,2     Enable Line ID Option</p>
^B60	<p>Define Console / Modem Port Bits and Parity ^B60[,port][,set]</p> <p>Where:</p> <p>[,port]     <b>Port:</b> When this argument is omitted, the command will be applied to the Console Port by default. Options:</p> <p>          ,C     Set Bits/Parity for Console Port</p> <p>          ,M     Set Bits/Parity for Modem Port</p> <p>[,set]     <b>Bits / Parity Setting:</b> Offers the Following Options:</p> <p>          ,1     Set Selected Port to 7 Bits, Even Parity</p> <p>          ,2     Set Selected Port to 7 Bits, Odd Parity</p> <p>          ,3     Set Selected Port to 8 Bits, No Parity</p> <p>          ,4     Set Selected Port to 7 Bits, No Parity</p>
^B61	<p>Define PBX Port Bits and Parity ^B60[,port][,set]</p> <p>Where:</p> <p>[,port]     <b>Port:</b> If this argument is omitted, the command will be applied to PBX Port A by default. Options:</p> <p>          ,A     PBX Port A</p> <p>          ,B     PBX Port B (Not Available on NLJ-VIP Models)</p> <p>          ,X     AUX Port (Not Available on NLJ-VIP Models)</p> <p>[,set]     <b>Bits / Parity Setting:</b> Offers the Following Options:</p> <p>          ,1     Set Selected Port to 7 Bits, Even Parity</p> <p>          ,2     Set Selected Port to 7 Bits, Odd Parity</p> <p>          ,3     Set Selected Port to 8 Bits, No Parity</p> <p>          ,4     Set Selected Port to 7 Bits, No Parity</p>
^B62	<p>Select Output Format</p> <p>^B62,1     Release Data in ASCII Format</p> <p>^B62,2     Release Data in ASCII Format</p> <p>^B62,3     Release Data in Binary Block Format</p> <p>^B62,4     Release Data in Xmodem Format</p> <p>^B62,5     Release Data in Zmodem Format</p>

Cmd.	Description / Options
^B64	Enable / Disable Wrap Around Mode ^B64,1     Disable Wrap Around Mode ^B64,2     Enable Wrap Around Mode
^B65	Select Alarm Filters ^B65[,port][,filter] Where: [,port] <b>Input Port:</b> If this argument is omitted, the command will be applied to PBX Port A by default. Options: ,A     PBX Port A ,B     PBX Port B (Not Available on NLJ-VIP Models) ,X     AUX Port (Not Available on NLJ-VIP Models) ,I     PBX IP Port [,filter] <b>Alarm Filter:</b> Offers the Following Options: ,1     Disable Alarm Filter at Selected Port ,2     Assign Alarm Filter #1 to Selected Port ,3     Assign Alarm Filter #2 to Selected Port
^B66	Enable / Disable Time/Date Stamp ^B66[,port][,action] Where: [,port] <b>Input Port:</b> If this argument is omitted, the command will be applied to PBX Port A by default. Options: ,A     PBX Port A ,B     PBX Port B (Not Available on NLJ-VIP Models) ,X     AUX Port (Not Available on NLJ-VIP Models) ,I     PBX IP Port [,action] <b>Enable / Disable Time/Date Stamp:</b> Offers the Following: ,1     Disables Time/Date Stamp at Selected Port ,2     Enables Time/Date Stamp at Selected Port ,3     Enable Long Format Time/Date Stamp at Port
^B67	Set Auto Delete Option ^B67,1     Disable Auto Delete Option ^B67,2     Enable Auto Delete Option
^B68	Set Command Echo ^B68,1     Disable Command Echo ^B68,2     Enable Command Echo

Cmd.	Description / Options
^B70	Enable / Disable Immediate Callout and 80% Full Alarm
	^B70 Disable Immediate Callout and 80% Full Alarm
	^B70,I Enable Immediate Callout
	^B70,I,1 Enable Immediate Callout
	^B70,I,1,1 Enable Immediate Callout
	^B70,I,1,2 Disable Immediate Callout
	^B70,I,2,n Define Immediate Callout Number (where n = Immediate Callout Number)
	^B70,I,2,[Space] Clear Immediate Callout Number
	^B70,% Enable 80% Full Alarm
	^B70,%,1 Enable 80% Full Alarm
	^B70,%,1,1 Enable 80% Full Alarm
	^B70,%,1,2 Disable 80% Full Alarm
	^B70,%,2,x Define Alarm Action, where x is the desired action and 1 = None, 2 = Callout, 3 = Alpha Page, 4 = Numeric Page, 5 = SNMP Trap, 6 = Output Contact Action, 7 = Console Action
	^B70,%,3,n Define number for 80% Full callout or page (where n is the desired phone number)
	^B70,%,3,[Space] Clear 80% Full Callout Number
	^B70,%,4,PagerID Define Pager ID Number 1 for 80% Full Alarm
	^B70,%,4,[Space] Clear Pager ID Number 1
	^B70,%,5,PagerID Define Pager ID Number 2 for 80% Full Alarm
	^B70,%,5,[Space] Clear Pager ID Number 2
	^B70,%,6,PagerID Define Pager ID Number 3 for 80% Full Alarm
	^B70,%,6,[Space] Clear Pager ID Number 3
	^B70,%,7,message Define 80% Full Alarm Message
	^B70,%,7,[Space] Clear 80% Full Alarm Message
^B70,%,8,1 Enable Auto Execute Function for 80% Full Alarm	
^B70,%,8,2 Disable Auto Execute Function for 80% Full Alarm	
^B70,%,9,cmds Define Auto Execute Command String for 80% Full Alarm	
^B70,%,9,[Space] Clear 80% Full Auto Execute String	
^B71	Set DLE Stuffing Option
	^B71,1 Disable DLE Stuffing Option ^B71,2 Enable DLE Stuffing Option
^B72	Display Time, Day, Date
^B73	Send Binary Information Block
^B74	Save / Recall Parameters
	^B74 Save Current Parameters to Flash Memory
	^B74,1 Save Current Parameters to Flash Memory
	^B74,2 Recall Parameters from Flash Memory ,Y (Optional Argument) Suppress "Sure?" Prompt
^B75	Enable / Disable "Sure?" Prompt
	^B75,1 Disable "Sure?" Prompt
	^B75,2 Enable "Sure?" Prompt

<b>Cmd.</b>	<b>Description / Options</b>
^B76	Release Remote Partition
^B76	Release Console Port Partition
^B76,c	Release Console Port Partition
^B76,m	Release Modem Port Partition
^B76,T1	Release Partition for Telnet Port 1
^B76,T2	Release Partition for Telnet Port 2
^B76,T3	Release Partition for Telnet Port 3
,y	(Optional Argument) Suppress "Sure?" Prompt
^B77	Define Modem Initialization Message
^B77,init	Defines "init" as the Modem Initialization Message
^B78	Display Modem Message
^B79	Define / Display Passwords
^B79	Displays Supervisor Level Password
^B79,pass	Defines "pass" as the Supervisor Level Password
^B79,1,pass	Defines "pass" as the Supervisor Level Password
^B79,2	Displays the User #1 Password
^B79,2,pass	Defines "pass" as the User #1 Password
^B79,3	Displays the User #2 Password
^B79,3,pass	Defines "pass" as the User #2 Password
^B83	Display Alarm Clue Summary
^B83,1	Display Clue Summary for Alarm Filter 1
^B83,2	Display Clue Summary for Alarm Filter 2
^B84	Clear Alarm Condition
^B84	Clear Alarm Condition
^B84,y	Clear Alarm Condition, Suppress "Sure?" prompt
^B86	Reset Alarm Clue Counters
^B86,clue	Reset Counter for "clue" only
^B86,*,A1	Reset All Counters for Alarm Filter 1
^B86,*,A2	Reset All Counters for Alarm Filter 2
^B86,*	Reset All Counters for Alarm Filters 1 and 2
^B89	Test Alphanumeric Pager
^B89,1	Test Alphanumeric Pager



Cmd.	Description / Options
^B90	Reset Modem Port / Define Modem Communication Parameters
	<b>Reset Modem Port:</b> Uses the Following Formats:
	^B90        Reset Modem Port
	^B90,Y     Suppress "Sure" Prompt, Reset Modem Port
	<b>Configure Modem Port:</b> Uses the Following Format:
	^B90[,baud][,parity][,data][,stop]
	Where:
	[,baud] <b>Baud Rate:</b> Can be any standard rate from 300 bps to 115.2 Kbps. If an asterisk is entered, the port will be set to the default modem port baud rate (57.6 Kbps).
	[,parity] <b>Parity Bits:</b> Offers the Following Options: ,N        No Parity ,O        Odd Parity ,E        Even Parity
	[,data] <b>Data Bits:</b> Offers the Following Options: ,7        Seven Data Bits ,8        Eight Data Bits
	[,stop] <b>Stop Bits:</b> Offers the Following Options: ,1        1 Stop Bit ,2        2 Stop Bits
^B91	Define Console Port Communication Parameters
	^B91[,baud][,parity][,data][,stop]
	Where:
	[,baud] <b>Baud Rate:</b> Can be any standard rate from 300 bps to 115.2 Kbps. If an asterisk is entered, the port will be set at the default rate specified by Setup Switches 1, 2, and 3.
	[,parity] <b>Parity Bits:</b> Offers the Following Options: ,N        No Parity ,O        Odd Parity ,E        Even Parity
	[,data] <b>Data Bits:</b> Offers the Following Options: ,7        Seven Data Bits ,8        Eight Data Bits
	[,stop] <b>Stop Bits:</b> Offers the Following Options: ,1        1 Stop Bit ,2        2 Stop Bits

<b>Cmd.</b>	<b>Description / Options</b>
^B92	Define PBX Port A Communication Parameters ^B92[,baud][,parity][,data][,stop] Where: [,baud] <b>Baud Rate:</b> Can be any standard rate from 300 bps to 115.2 Kbps. If an asterisk is entered, the port will be set at the default rate specified by Setup Switches 4 and 5. [,parity] <b>Parity Bits:</b> Offers the Following Options: ,N     No Parity ,O     Odd Parity ,E     Even Parity [,data] <b>Data Bits:</b> Offers the Following Options: ,7     Seven Data Bits ,8     Eight Data Bits [,stop] <b>Stop Bits:</b> Offers the Following Options: ,1     1 Stop Bit ,2     2 Stop Bits
^B93	Define PBX Port B Communication Parameters ^B93[,baud][,parity][,data][,stop] Where: [,baud] <b>Baud Rate:</b> Can be any standard rate from 300 bps to 115.2 Kbps. If an asterisk is entered, the port will be set at the default rate specified by Setup Switches 4 and 5. [,parity] <b>Parity Bits:</b> Offers the Following Options: ,N     No Parity ,O     Odd Parity ,E     Even Parity [,data] <b>Data Bits:</b> Offers the Following Options: ,7     Seven Data Bits ,8     Eight Data Bits [,stop] <b>Stop Bits:</b> Offers the Following Options: ,1     1 Stop Bit ,2     2 Stop Bits
^B94	Enter Monitor Mode ^B94,A     Monitor PBX Port A ^B94,B     Monitor PBX Port B (Not Available on NLJ-VIP Models) ^B94,X     Monitor AUX Port (Not Available on NLJ-VIP Models) ^B94,I     Monitor PBX IP Port ^B94,C     Monitor Console Port ^B94,M     Monitor Modem Port
^B95	Display Program Version

Cmd.	Description / Options
^B96	Define AUX Port Communication Parameters ^B96[,baud][,parity][,data][,stop]
	Where:
	[,baud] <b>Baud Rate:</b> Can be any standard rate from 300 bps to 115.2 Kbps. If an asterisk is entered, the port will be set at the default rate specified by Setup Switches 4 and 5.
	[,parity] <b>Parity Bits:</b> Offers the Following Options: ,N       No Parity ,O       Odd Parity ,E       Even Parity
	[,data] <b>Data Bits:</b> Offers the Following Options: ,7       Seven Data Bits ,8       Eight Data Bits
	[,stop] <b>Stop Bits:</b> Offers the Following Options: ,1       1 Stop Bit ,2       2 Stop Bits
^B97	Define/Display Network Parameters
	^B97        Display Network Parameters
	^B97,1,IPADDR   Define IP Address; Where IPADDR is the desired IP Address
	^B97,1,[Space]   Clear IP Address
	^B97,2,SUBNET   Define Subnet Mask Address; Where SUBNET is the desired Subnet Mask Address
	^B97,2,[Space]   Clear Subnet Mask Address
	^B97,3,GATE     Define Gateway Address; Where GATE is the desired Gateway Address
	^B97,3,[Space]   Clear Gateway Address
	^B97,4,SNMP1    Define SNMP Manager #1; Where SNMP1 is the desired SNMP Address
	^B97,4,[Space]   Clear SNMP Manager #1
	^B97,5,SNMP2    Define SNMP Manager #2; Where SNM2 is the desired SNMP Manager
	^B97,5,[Space]   Clear SNMP Manager #3
	^B97,6,SNMPC    Define SNMP Community; Where SNMPC is the desired SNMP Community
	^B97,6,[Space]   Clear SNMP Community
^B98	Reset Network Port
	^B98        Reset Network Port
	^B98,Y       Suppress "Sure" Prompt, Reset Network Port
^B99	Save Current Parameters



# Index

<b>Symbols</b>		
100Base-T		4-7
10Base-T		4-7
80% Full Alarm	11-1 to 11-2, 19-21	
Action		11-1
Auto Execute		11-2
Email To		11-2
Execute Commands		11-2
Message		11-2
Output Contacts		11-2
Pager I.D.		11-1
Phone Number		11-1
SNMP Management		11-1
Status Screen		7-12
<b>A</b>		
Account		
FTP Push		16-15
Action		
80% Full Alarm		11-1
Alarm Filter		9-10
Input Contact Alarm		12-2
Scheduled Action		14-3
Action Delay		
Console Port		5-13
Modem Port		5-16
Network Port		5-21
Action Parameters		
Alarm Filter		9-10
PBX Inactivity Alarm		10-4
Scheduled Action		14-3
Action Schedule		19-10
AC Powered Units		4-1
AC Power Components		2-2
Alarm Actions	9-3, 13-1 to 13-7	
Alarm Filter		13-2
Alphanumeric Page		13-1, 13-3
Auto Execute		13-7
Callout		13-1, 13-3
Console		13-1, 13-5
Email		13-1, 13-6
None		13-1, 13-2
Numeric Page		13-1, 13-4
Output Contact		13-1, 13-5
SNMP Trap		13-1, 13-4
Text Message		13-1, 13-6
Alarm Clue		
Definition Tips		Apx-7
Display Summary		19-24
Alarm Condition Status Screen		7-9
Alarm Data		
Store		19-14
Wrap-Around		5-5
Alarm Filter	9-1 to 9-18	
Action		9-3
Action Parameters		9-10
Alarm Actions		13-2
Alarm Counter Reset Time		9-5
Auto Execute		9-3
AUX Port		5-11
Clear Alarm		19-24
Clues		9-8 to 9-13
Clue Definition Tips	Apx-7 to Apx-9	
Clue Name		9-9
Clue Status Screen		7-25
Configuration Menus		9-2 to 9-14
Contains String		9-12
Default Actions		9-2 to 9-4
Define Format		9-5
Delete Clues		9-5, 9-10
Display Clue Details		9-5, 9-10
Edit Clues		9-5, 9-10
Email To		9-4
Execute Commands		9-4
Format		9-5 to 9-7
Match Parameters		9-10
Message		9-3
Operators		9-11 to 9-12
Output Contacts		9-3
Pager I.D.		9-3
PBX IP Port		5-27
PBX Port		5-7
Phone Number		9-3
Real-Time Variables		9-13
Reset Clue Counters		19-25
Select		19-19
Send Alarm Record		9-4
SNMP Management		9-3
Threshold		9-9
Alarm Message		19-10
Alarm Record		
Display Current		19-9
ALM Indicator		2-1
Alphanumeric Page		
Alarm Action		13-1, 13-3
Test Pager		19-25



Command Reference Guide	19-1 to 19-30	Data Filter	8-1 to 8-12
Command Syntax	19-2	Action	8-5
Command Timeout		And/Or Conditions	8-7
Console Port	5-13	Assigning to a Port	8-9
Modem Port	5-16	AUX Port	5-11
Network Port	5-21	Clues	8-4 to 8-5, 8-5 to 8-6
Comparative Operators	Apx-7	Clue Name	8-5
Configuration	5-1 to 5-28	Configuration Menus	8-1 to 8-12
Conflicts		Contains String	8-8
Telnet	18-8	Delete Clues	8-6
Consecutive Lost Packets	5-25	Display Clue Details	8-5
Console		Edit Clues	8-6
Alarm Action	13-5	Examples	8-9 to 8-12
Scheduled Action	14-1	Format	8-2 to 8-4
Console Port	2-2, 4-7, 5-12 to 5-14	Match Parameters	8-5
Action Delay	5-13	Operators	8-6
Audit Trail	5-13	PBX IP Port	5-28
Auto Delete	5-14	PBX Port	5-7
Baud Rate	5-12	Real-Time Variables	8-8
Bits and Parity	5-12, 19-17	Select	19-16
Command Echo	5-12	Variables	8-5
Command Timeout	5-13	Data Filters and Alarms	
Data on ^B01	5-13	Status Screen	7-7 to 7-8
Default Baud Rate	4-2	Data on ^B01	19-6
Define Parameters	19-26	Console Port	5-13
DLE Stuffing	5-14	Modem Port	5-16
Handshake	5-12	Network Port	5-22
Hold End Data	5-13	Data Release Mode	19-5 to 19-6
Interface	Apx-4	Data Type	16-2 to 16-3, 16-8
Line Number Tag	5-14	Alarm	16-8
Output Mode	5-13	All	16-8
Password	4-3	By Clue	16-8
Response Type	5-13	FTP Push	16-16, 16-20
Send Compressed	5-14	FTP Server	16-28
Status Screen	7-17 to 7-18	Non-Alarm	16-8
Stop Bits	5-12	Standard	16-8
Sure Prompt	5-13	DCD Indicator	2-1
Transmit Attempts	5-14	DC Powered Units	4-2
Transmit Delay	5-14	DC Power Components	2-2
Contact Monitor	2-3	Default Baud Rate	
Continuous Binary Block Read	16-13, 19-8	Console Port	4-2
CP Indicator	2-1	PBX Port	4-3
Customer Service	Apx-10	Default Parameters	4-4 to 4-5, 17-10, 19-13
		Define Format	
		Alarm Filter	9-5 to 9-7
		Delete Clues	
		Alarm Filter	9-5, 9-10
		Destination Number Location	5-9
		Dialback Security	4-3, 5-18 to 5-19
		Status Screen	7-6
		Supervisor Dialback Number	5-19
		User Dialback Number	5-19
		Dial Attempts	5-17

Dip Switches	2-3	End of Record Character	
Display Settings	19-11	Define	19-7
Directory		Erase All Data	16-7, 19-13
FTP Push	16-15	Erase Partition Data	16-7, 19-11
Disconnect		Exclusions	
PBX IP Port	5-28	PBX Inactivity Alarm	10-3
Display Alarm Record	16-13, 19-9	Scheduled Action	14-2
Display Clue Details		Exit Command Mode	19-9
Alarm Filter	9-5, 9-10		
Display Program Version	19-28	<b>F</b>	
Display Record Count	19-11	Field Suppression	5-8
Display Remaining Space	19-11	AUX Port	5-11
Display Site I.D.	19-6	PBX IP Port	5-28
Display Time & Date	19-22	PBX Port	5-7
DLE Stuffing	19-22	Files	16-2 to 16-3
Console Port	5-14	File Extension	
Modem Port	5-17	FTP Push	16-20
Network Port	5-22	Increment	16-15
		File List Screen	7-3
<b>E</b>		File Mode	
Echo Test Mode	19-12	FTP Push	16-15
Edit Clues		File Name	
Alarm Filter	9-5, 9-10	FTP Push	16-15, 16-19
Email		FTP Server	16-23, 16-28
Alarm Action	13-6	Firmware Tree	6-1 to 6-8
Scheduled Action	14-1	Firmware Updates	17-6 to 17-7
Email and Text Messaging	5-23 to 5-24	Firmware Version	
Authentication Type	5-24	Display	19-28
From Address	5-24	Force FTP Push	16-18
From Name	5-24	From Address	5-24
IP Address	5-23	From Name	5-24
Last Email Status	5-24	Front Panel Indicators	2-1
Password	5-23	FTP Push	16-14 to 16-21
Port Number	5-23	Account	16-15
Priority	5-24	Auto Delete	16-18
Send Test Email	5-24	Data Type	16-16, 16-20
Stop Email Session	5-24	Directory	16-15
Subject	5-24	File Extension	16-20
To Address	5-24	File Extension Increment	16-15
To Name	5-24	File Mode	16-15
User Name	5-23	File Name	16-15, 16-19
Email Configuration	5-23 to 5-24	Force FTP Push	16-18
Email Subject	5-24	Password	16-15
Email To		Periodic Push	16-17
80% Full Alarm	11-2	Push Action	16-17
Alarm Filter	9-4	Read Session	16-16
Input Contact Alarm	12-4	Server Address	16-14
PBX Inactivity Alarm	10-5	Source Port	16-16, 16-19
End Character		Start Record	16-17
AUX Port	5-11	Start Time	16-18, 16-21
PBX IP Port	5-27	Stop FTP Push	16-18
PBX Port	5-7	Test FTP Push	16-18
End Data Message		Transmit Attempts	16-18
Enable/Disable	19-14	Transmit Delay	16-18
		User Name	16-15



FTP Server	16-22 to 16-31		
Audit Trail	16-23		
Auto Delete	16-23		
Commands Supported	16-29		
Configuration	16-22 to 16-23		
Data Type	16-28		
File Name	16-23, 16-28		
Password	16-22		
Response Messages	16-30		
Retrieving Data	16-24 to 16-25		
Source Port	16-28		
Stop FTP Session	16-23		
User Name	16-22		
		<b>G</b>	
Gateway Address	5-20		
Grounding	i		
		<b>H</b>	
Half Duplex Mode	4-7		
Handshake Mode	19-16		
AUX Port	5-10		
Console Port	5-12		
Modem Port	5-15		
PBX Port	5-6		
Hang-Up String	5-15		
Hardware Installation	4-1 to 4-8		
Help Screens	19-3		
HIPPA Compliance	5-8		
Hold End Data			
Console Port	5-13		
Modem Port	5-17		
Network Port	5-22		
		<b>I</b>	
I/O Monitor	2-3, 9-3, 12-1 to 12-4		
Immediate Callout	5-18		
Immediate Phone Number	5-18		
Inbound Trunk Location	5-9		
Initialize String	5-15		
Input Contact Alarm	12-1 to 12-4		
Action	12-2		
Auto Execute	12-4		
Email To	12-4		
Message	12-4		
Output Contacts	12-4		
Pager I.D.	12-3		
Phone Number	12-3		
SNMP Management	12-3		
Status Screen	7-13		
Trigger Level	12-2		
Input Indicators	2-1		
Installation	4-1 to 4-8		
IP Address	5-20		
Email and Text Messaging	5-23		
Ping Function	5-25		
		<b>K</b>	
Keep Alive Response	5-27		
Keep Alive Send	5-27		
		<b>L</b>	
Last Email Status	5-24		
Last Ping Status	5-25		
Last Status			
PBX IP Port	5-28		
LEDs	2-1		
Line I.D. Option	19-17		
Line Number Tag	19-17		
Console Port	5-14		
Modem Port	5-17		
Network Port	5-22		
Load & Test Memory	17-8		
Local Access	5-2		
Lucent Switch	5-7, 5-8 to 5-9, 5-11		
AUX Port	5-11		
Call Direction	5-8		
Destination Number Length	5-9		
Destination Number Location	5-9		
Inbound Trunk Length	5-9		
Inbound Trunk Location	5-9		
Number of Characters	5-8		
Outbound Trunk Length	5-9		
Outbound Trunk Location	5-9		
PBX IP Port	5-28		
PBX Port	5-7		
Source Number Length	5-9		
Source Number Location	5-9		
Suppress Number	5-8		
Suppress Trunk	5-8		
		<b>M</b>	
Match Parameters	Apx-9		
Alarm Filter	9-10		
Memory			
Display Capacity	19-11		
Display Remaining	16-13, 19-11		
Memory Indicators	2-1		
Memory Partition	16-1 to 16-3		
Display Record Count	19-11		
Erase Data	19-11		
Release Remote	19-23		
Releasing	16-5, 19-4		
Setting	16-4		
Memory Usage	2-1		
Memory Wrap-Around	5-5		
Menu System	5-3 to 5-27, 6-1 to 6-8		

Message			<b>N</b>
80% Full Alarm	11-2	Network Port	2-3, 4-7, 5-20 to 5-22
Alarm Filter	9-3	Action Delay	5-21
Input Contact Alarm	12-4	Audit Trail	5-21
PBX Inactivity Alarm	10-4	Auto Delete	5-22
Scheduled Action	14-4	Command Echo	5-21
Modem		Command Timeout	5-21
Hang-Up String	5-15	Data on ^B01	5-22
Initialize String	5-15, 19-23	Define Parameters	19-29
Test	19-12	DLE Stuffing	5-22
Modem Indicators	2-1	Gateway Address	5-20
Modem Initialize String	5-15	Hold End Data	5-22
Modem Port	2-3, 4-7, 5-15 to 5-20	IP Address	5-20
Action Delay	5-16	Line Number Tag	5-22
Audit Trail	5-16	Output Mode	5-22
Auto Delete	5-17	Ping	5-21
Baud Rate	5-15	Reset	19-29
Bits and Parity	5-15, 19-17	Reset Network	5-20
Command Echo	5-16	Response Type	5-21
Command Timeout	5-16	Send Compressed	5-22
Data on ^B01	5-16	Send Email	5-21
Define Parameters	19-26	Send MSS	5-21
Dialback Security	5-18 to 5-19	SNMP Community	5-20
Dial Attempts	5-17	SNMP Manager	5-20
Display Strings	19-24	Status Screen	7-21 to 7-22
DLE Stuffing	5-17	Subnet Mask	5-20
Handshake Mode	5-15	Sure Prompt	5-21
Hang-Up String	5-15	Transmit Attempts	5-22
Hold End Data	5-17	Transmit Delay	5-22
Immediate Callout	5-18	Network Status Screen	7-23
Immediate Phone Number	5-18	Non-Data	Apx-8
Initialize String	5-15	Non-Printable Characters	5-7, 5-11, 5-27, 19-15
Line Number Tag	5-17	Number of Stored Records	16-13
Output Mode	5-16	Numeric Page	
Reset	19-26	Alarm Action	13-1, 13-4
Reset Modem	5-15		
Reset String	5-15	<b>O</b>	
Response Type	5-16	OH Indicator	2-1
Send Compressed	5-17	ON Indicator	2-1
Sequence Attempts	5-17	Operators	Apx-7
Sequence Delay	5-17	Alarm Filter	9-11
Status Screen	7-19 to 7-20	Data Filter	8-6
Stop Bits	5-15	Outbound Trunk Location	5-9
Sure Prompt	5-16	Output Contacts	
Transmit Attempts	5-17	Alarm Action	13-1, 13-5
Transmit Delay	5-17	80% Full Alarm	11-2
Modem Reset	5-15	Alarm Filter	9-3
Modem Reset String	5-15	Input Contact Alarm	12-4
Monitor Mode	19-28	PBX Inactivity Alarm	10-4
Multiple Telnet Connections	18-7	Scheduled Action	14-1, 14-3
		Output Format	19-18

Output Mode		PBX Inactivity Alarm <i>(continued)</i>	
Console Port	5-13	Schedules and Timers	10-1
Modem Port	5-16	SNMP Management	10-4
Network Port	5-22	Status Screen	7-10 to 7-11
	<b>P</b>	Weekday Alarm	10-2
Packet Delay	5-25	Weekday Schedule	10-2
Packet Size	5-25	Weekday Timer	10-2
Page		Weekend Alarm	10-2
Scheduled Action	14-1	Weekend Schedule	10-3
Pager		Weekend Timer	10-3
Test	17-9, 19-25	PBX Input Connectors	2-2
Pager I.D.		PBX IP Port	
80% Full Alarm	11-1	Alarm Filter	5-27
Alarm Filter	9-3	Configuration	5-26 to 5-27
Input Contact Alarm	12-3	Data Filter	5-28
PBX Inactivity Alarm	10-4	Disconnect	5-28
Scheduled Action	14-3	End Character	5-27
Parameters		Keep Alive Response	5-27
Restoring	15-2 to 15-5, 19-22	Keep Alive Send	5-27
Saving	15-1 to 15-5, 19-22, 19-30	Last Status	5-28
Set to Defaults	19-13	PBX Inactivity Alarm	5-28
Parity		Port Number	5-26
AUX Port	5-10	SDM Response	5-27
Console Port	5-12	Serial Number Stamp	5-27
Modem Port	5-15	Service	5-26
PBX Port	5-6	Status Screen	7-24 to 7-25
Partition	16-1 to 16-3	Store Alarm Data	5-27
Display Record Count	19-11	Strip Non-Printables	5-27
Erase Data	19-11	Time/Date Stamp	5-27
Release Remote	19-23	Window Size	5-26
Releasing	16-5, 16-10	PBX Port	4-7, 5-6 to 5-9
Setting	16-4, 16-10, 19-4	Alarm Filter	5-7
Pass-Through Mode	17-2, 19-12	Baud Rate	5-6
Password	3-2, 19-24	Bits and Parity	5-6, 19-18
Console Port	4-3	Data Filter	5-7
Email and Text Messaging	5-23	Default Baud Rate	4-3
FTP Push	16-15	Define Parameters	19-27
FTP Server	16-22	Display Baud Rate	19-11
Supervisor	5-4	End Character	5-7
User	5-4	Handshake Mode	5-6
PBX Inactivity Alarm	10-1 to 10-5	Interface Diagram	Apx-3
Action	10-4	Lucent Switch	5-7
Auto Execute	10-5	PBX Inactivity Alarm	5-7
AUX Port	5-11	Serial Number Stamp	5-6
Display Parameters	19-10	Status Screen	7-15
Email To	10-5	Stop Bits	5-6
Exclusions	10-3	Store Alarm Data	5-7
Execute Commands	10-5	Strip Non-Printables	5-7
Message	10-4	Time/Date Stamp	5-6
Output Contacts	10-4	Periodic Push	
Pager I.D.	10-4	FTP Push	16-17
PBX IP Port	5-28		
PBX Port	5-7		
Phone Number	10-4		

Phone Number		Reset Button	2-3
80% Full Alarm	11-1	Reset Modem	5-15
Input Contact Alarm	12-3	Reset Network	5-20
PBX Inactivity Alarm	10-4	Reset String	5-15
Scheduled Action	14-3	Reset to Defaults	4-5
Ping Function	5-21, 5-25	Response Delay	
Consecutive Lost Packets	5-25	Ping Function	5-25
IP Address	5-25	Response Messages	
Last Ping Status	5-25	FTP Server	16-30
Packet Delay	5-25	Response Type	
Packet Size	5-25	Console Port	5-13
Response Delay	5-25	Modem Port	5-16
Send Packets	5-25	Network Port	5-21
Start Ping	5-25	Restoring Parameters	15-5
Stop Ping Session	5-25	Retrieving Data	19-5
Polling Data	16-1 to 16-32		
Port A Indicator	2-1	<b>S</b>	
Port B Indicator	2-1	Saving Parameters	15-1 to 15-5, 19-30
Port Configuration	5-6 to 5-28	To an ASCII File	15-2
Port Mode	5-11	To Flash Memory	15-1
Port Number		Scheduled Action	14-1 to 14-4
Email and Text Messaging	5-23	Action Parameters	14-3
PBX IP Port	5-26	Auto Execute	14-4
Power Supply	i, 4-1 to 4-2	Callout	14-1
Power Up Default	4-4	Console	14-1
Priority	5-24	Daily Schedule	14-2
Push Action		Display Schedule	19-10
FTP Push	16-17	Email	14-1
		Email To	14-4
<b>Q</b>		Exclusions	14-2
Quick Start	3-1 to 3-4	Message	14-4
		Output Contact	14-1, 14-3
<b>R</b>		Page	14-1
Rack Mounting	i	Pager I.D.	14-3
Raw Socket Mode	18-1	Phone Number	14-3
RDY Indicator	2-1	SNMP Management	14-3
Re-read Last Data	16-7	SNMP Trap	14-1
Re-send Last Data	19-7	Status Screen	7-5
Read Session		Text Message	14-1
FTP Push	16-16	Script Access	5-3
Read Session Parameters	16-6	SDM Response	5-27
Real-Time Clock	5-5, 8-8, 9-13	Security Level	17-1, Apx-5 to Apx-6
Set Time & Date	19-9	Selective Read	18-5
Real-Time Mode	18-3	Send Alarm Record	
Real-Time Variables		Alarm Filter	9-4
Alarm Filter	9-13	Send Compressed	
Reason For Action	7-14	Console Port	5-14
Display	19-10	Modem Port	5-17
Record Count	16-9	Network Port	5-22
Release Data on ^B01	19-15	Send Email	5-21
Release Partition	16-9, 16-10	Send MSS	5-21
Release Remote Partition	16-7	Send Next Data	19-6
Remaining Memory	16-13	Send Packets	5-25
Remote Partition		Send Test Email	5-24
Release	19-23	Send Test Message	17-8

Send Test SNMP Trap	17-10	Stop Ping Session	5-25
Separator Line	16-13, 19-12	Store Alarm Data	19-14
Sequence Attempts	5-17	AUX Port	5-11
Sequence Delay	5-17	PBX IP Port	5-27
Serial Number Stamp		PBX Port	5-7
AUX Port	5-11	Strip Non-Printables	19-15
PBX IP Port	5-27	AUX Port	5-11
PBX Port	5-6	PBX IP Port	5-27
Server Address		PBX Port	5-7
FTP Push	16-14	Subject	5-24
Service		Subnet Mask	5-20
PBX IP Port	5-26	Supervisor Mode	Apx-5 to Apx-6
Set-Up Switches	2-3, 4-2 to 4-4, 16-13	Supervisor Password	5-4
Display Settings	19-11	Suppress Number	5-8
Set Compression Mode	19-14	Suppress Trunk	5-8
Set Partition	16-10	Sure Prompt	19-23
Set Time & Date	19-9	Console Port	5-13
Site I.D. Message	5-4, 16-13, 19-10	Modem Port	5-16
Define	19-7	Network Port	5-21
Display	19-6	System Diagnostics	17-8 to 17-10
SNMP Community	5-20	Load and Test Memory	17-8
SNMP Management		Send Test Message	17-8
80% Full Alarm	11-1	Send Test SNMP Trap	17-10
Alarm Filter	9-3	Test Pager	17-9
Input Contact Alarm	12-3	System Functions	17-1 to 17-7
PBX Inactivity Alarm	10-4	Audit Trail	17-5
Scheduled Action	14-3	Clear Alarm Condition	17-3
SNMP Manager	5-20	Clear Alarm Counters	17-4
SNMP Trap		Download Parameters	17-4
Alarm Action	13-1, 13-4	Monitor Mode	17-3
Scheduled Action	14-1	Pass-Through Mode	17-2
Test	17-10	Security Level	17-1
Software Version		Upload Firmware	17-6
Display	19-28	System Indicators	2-1
Source Number Location	5-9	System Parameters	5-4 to 5-5
Source Port	16-2, 16-8	Alarm Data Wrap-Around	5-5
FTP Push	16-16, 16-19	Real-Time Clock	5-5
FTP Server	16-28	Site I.D. Message	5-4
Specifications	Apx-1 to Apx-2	Supervisor Password	5-4
Standard Telnet	18-1	User Password	5-4
Start Ping	5-25	Wrap-Around	5-5
Start Record	16-9	System Status Screen	7-4, 19-10
FTP Push	16-17		
Start Time		<b>T</b>	
FTP Push	16-18, 16-21	TCP Port Options	18-1 to 18-8
Status Screens	7-1 to 7-25	Technical Support	Apx-10
Stop Bits		Telnet	
AUX Port	5-10	Conflicts	18-8
Console Port	5-12	Multiple Connections	18-7
Modem Port	5-15	Pass-Through	18-2
PBX Port	5-6	Raw Socket Mode	18-1
Stop Email Session	5-24	Real-Time Mode	18-3
Stop FTP Push	16-18	Selective Read	18-5
Stop FTP Session	16-23	Telnet Access	5-2
		Telnet Pass-Through	18-2

Telnet Port Numbers	18-1 to 18-8		
Terminal Block	2-2, 4-2	Upload Firmware	17-6
Test FTP Push	16-18	User Mode	Apx-5 to Apx-6
Test Message Mode	19-12	User Name	
Test Pager	17-9	Email and Text Messaging	5-23
Text Message		FTP Push	16-15
Alarm Action	13-6	FTP Server	16-22
Scheduled Action	14-1	User Password	5-4
Text Messaging	5-23 to 5-24		
Threshold		<b>W</b>	
Alarm Filter	9-9	Warnings and Cautions	i
Time/Date Stamp	19-20	Weekday Alarm	
AUX Port	5-10	PBX Inactivity Alarm	10-2
PBX IP Port	5-27	Weekday Schedule	
PBX Port	5-6	PBX Inactivity Alarm	10-2
To Address	5-24	Weekday Timer	
To Name	5-24	PBX Inactivity Alarm	10-2
Transmit Attempts		Weekend Schedule	
Console Port	5-14	PBX Inactivity Alarm	10-3
FTP Push	16-18	Weekend Timer	
Modem Port	5-17	PBX Inactivity Alarm	10-3
Network Port	5-22	Window Size	
Transmit Delay		PBX IP Port	5-26
Console Port	5-14	Wrap-Around	
FTP Push	16-18	Alarm Data	5-5
Modem Port	5-17	Memory	5-5, 19-19
Network Port	5-22		
Trigger Level		<b>X</b>	
Input Contact Alarm	12-2	XON/XOFF	
		Enable/Disable	19-16
		<b>Z</b>	
		Zmodem Data Release	16-32

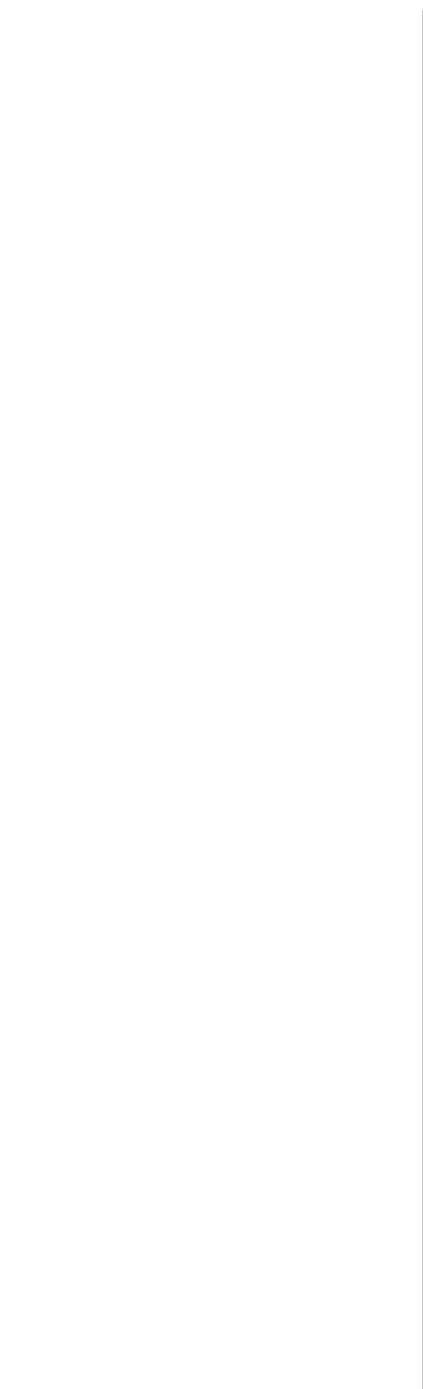

## **Trademark and Copyright Information**

---

WTI and Western Telematic are trademarks of Western Telematic Incorporated. All other product names mentioned in this publication are trademarks or registered trademarks of their respective companies.

Information and descriptions contained herein are the property of Western Telematic, Inc. Such information and descriptions may not be copied, disseminated or distributed without the express written consent of Western Telematic, Inc.

© Copyright Western Telematic, Inc., 2006. All rights reserved.

January  
P/N 13602 Rev. A







---

**5 Sterling · Irvine · California 92618**  
**(949) 586-9950 · Toll Free: 1-800-854-7226**  
**Fax: (949) 583-9514 · <http://www.wti.com>**