



Vax careline  
0870 1129 145  
(UK only)

# Carpet Washer

## VCW-02

Vax model number:  
VCW-02

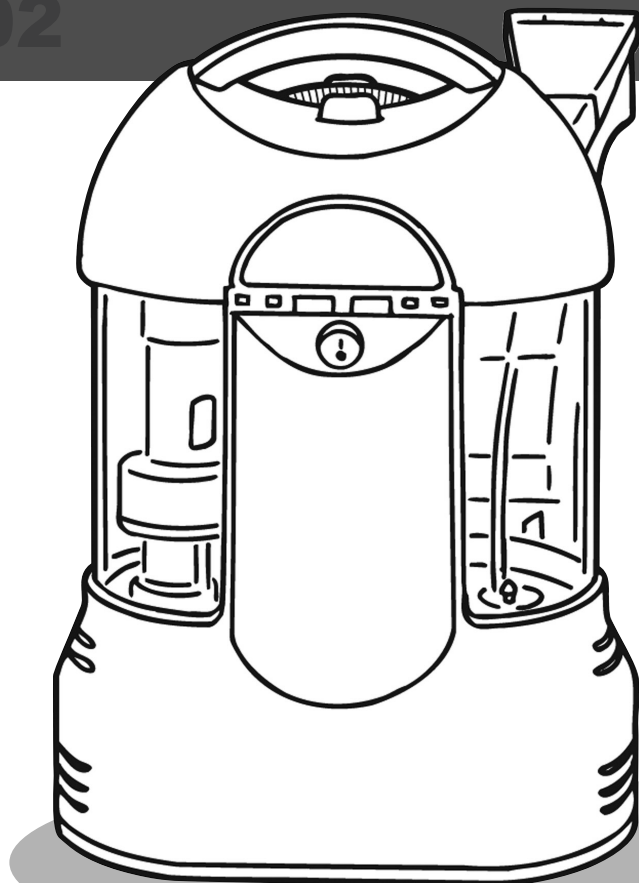

instruction manual

[www.vax.co.uk](http://www.vax.co.uk)

Please read carefully before using this cleaner.  
Always fully extend the mains cable before use.  
Retain for future reference.

# 1. Diagram

VCW-02

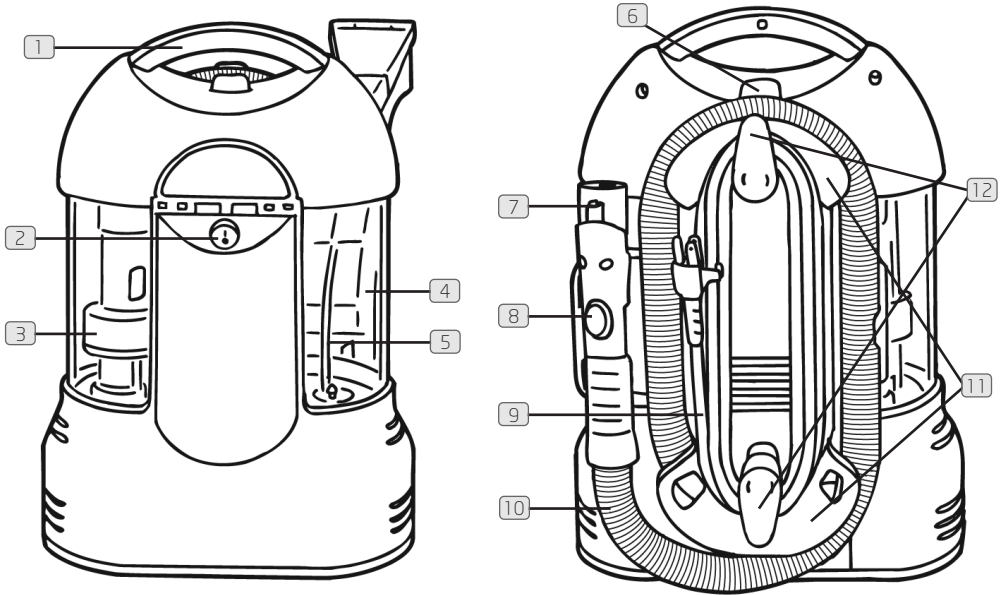
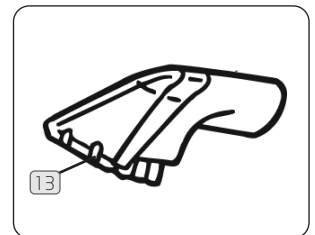

Fig.1/1

- |                        |                             |
|------------------------|-----------------------------|
| 1 Carry Handle         | 8 Solution Dispense Button  |
| 2 On/Off Switch        | 9 Power Cord                |
| 3 Dirty Water Tank     | 10 Attachment Hose          |
| 4 Clean Water Tank     | 11 Hose Wrap                |
| 5 Clean Water/Solution | 12 Quick Release Cord Hooks |
| 6 Lid Release Latch    | 13 Wash Tool                |
| 7 Spray Nozzle         |                             |



## 2. Safety Information

When using the carpet washer, basic safety precautions should always be observed, including the following:

1. Do not leave the carpet washer unattended when plugged in. Unplug it from socket when not in use.
2. To prevent electric shock do not use outdoors.
3. Not to be used as a toy. Close supervision is necessary when used by or near children or the infirm.
4. Use only as described in this manual.
5. Do not use with a damaged cord or plug. If the supply cord and/or plug is damaged, they must be replaced by the manufacturer, a Vax Service Agent or similarly qualified persons in order to avoid hazard.
6. Do not pull or carry by the cord, use the cord as a handle, allow the cord to come into contact with hot or sharp surfaces or close a door on the cord.
7. Do not unplug by pulling on the cord.
8. Do not handle the plug or carpet washer with wet hands.
9. Do not put any objects into openings or operate with openings blocked, keep them free of anything that may reduce airflow.
10. Keep hair, loose clothing, fingers and all parts of the body away from openings and moving parts.
11. Do not use the carpet washer on any glowing, burning or smoking particles.
12. Do not use without the solution tank and dirty water tank in place.
13. Turn off all controls before unplugging.
14. Do not use to pick up flammable or combustible liquids such as petrol, or use in areas where they may be present.
15. Keep the carpet washer on the floor.
16. Do not use an extension cord.
17. Do not attempt to remove blockages with sharp objects as they may cause damage.
18. Store indoors put away after use to prevent tripping accidents.
19. Using improper voltage may result in damage to the motor and possible injury to the user. The correct voltage is listed on the rating label.
20. A hazard may occur if the carpet washer runs over the power supply cord.
21. To prevent dirty water from running into motor, do not hold the appliance upside-down or lay on its side. Use appliance in normal vacuuming position.

22. Use extra care when cleaning on stairs.
23. Do not carry appliance while motor is running.
24. This appliance is not intended for use by persons ( including children ) with reduced physical, sensory or mental capabilities, or lack of experience and knowledge, unless they have been given supervision or instruction concerning use of the appliance by a person responsible for their safety.



**NOTE: Carpets should be dry vacuumed thoroughly before washing.**



**NOTE: If the supply cord is damaged, it must be replaced by the manufacturer, a Vax service agent or similarly qualified persons in order to avoid hazard.**



**NOTE: The carpet washer must be unplugged from the mains socket outlet after use, and before cleaning or maintaining the carpet washer.**



**NOTE: This appliance is not suitable for picking up hazardous dust.**



**NOTE: If foam/liquid comes out, switch off immediately.**

**This appliance is suitable for commercial use, for example in hotels, schools, hospitals, factories, shops and offices**

**PLEASE KEEP THESE INSTRUCTIONS FOR FURTHER USE.**

### 3. Preparing the Machine

**⚠ WARNING:** Use only Vax Commercial Carpet Cleaner with this machine. Using other cleaning solutions may cause excessive foaming. Excessive foam will cause the float to shut off the vacuum prematurely.

#### Filling Clean Water Tank

Press down on the Lid. Release Latch and tilt lid towards front of cleaner to access the tanks (Fig.3/1).

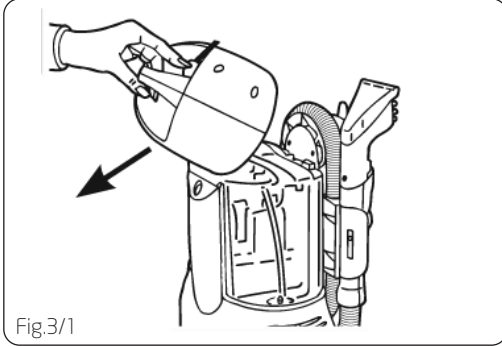

Remove Clean Water Tank by pulling up and out of cleaner (Fig.3/2).

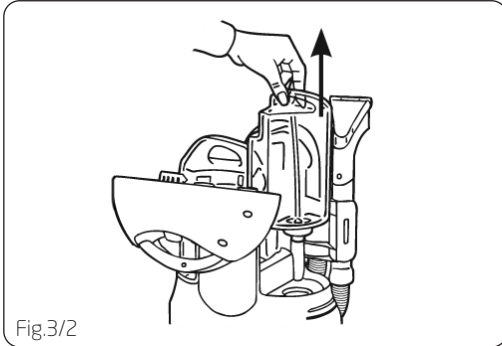

Unscrew cap and fill Clean Water Tank with solution up to the Soap Fill Line (Fig.3/3).

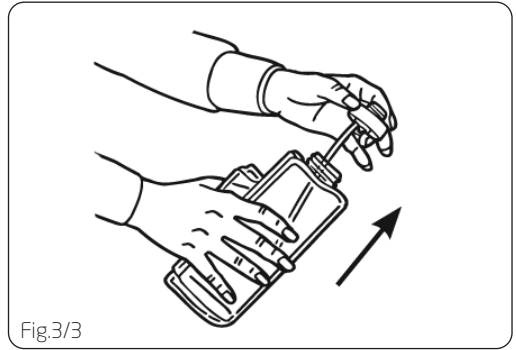

Fill the rest of the Clean Water Tank with warm tap water (MAX 40°C) up to the Water Fill Line (Fig.3/4).

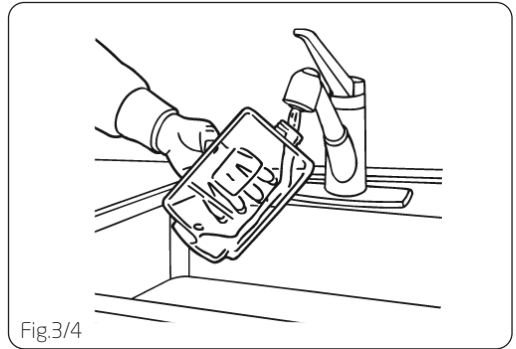

Replace Clean Water Tank cap and tighten firmly. Return Clean Water Tank to cleaner (Fig.3/5). Close lid making sure that the Lid Release Latch clicks into place (Fig.3/6).

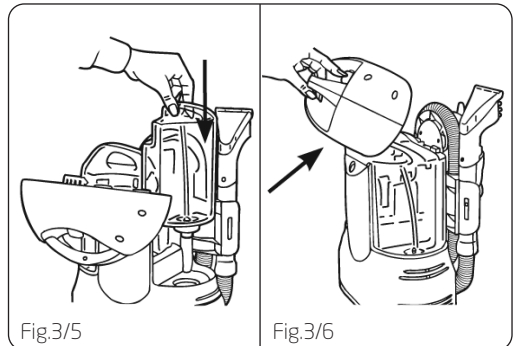

## 4. Attachments

**!** NOTE: Always turn off appliance before connecting or disconnecting attachments.

### Connecting Attachments

Connect desired attachment by pressing tool onto the end of the attachment hose until the locking button snaps into the hole (Fig.4/1).

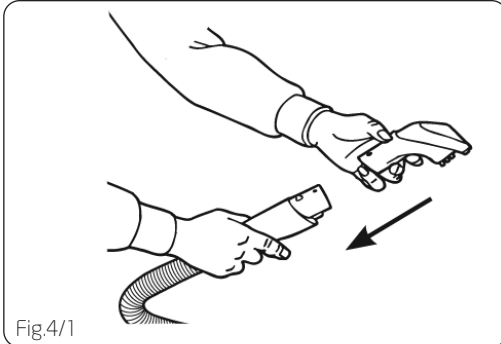

Fig.4/1

**!** WARNING: Keep spray pointed away from face. Failure to do so may result in personal injury.

To remove, press down on the locking button and pull the tool away from the hose (Fig.4/2).

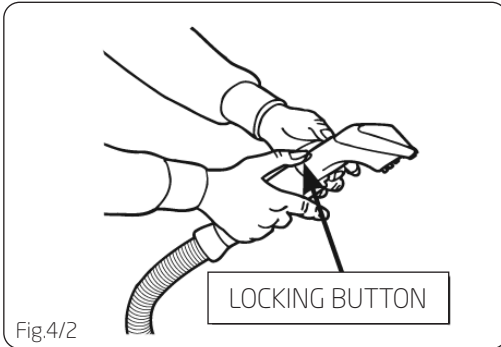

Fig.4/2

## 5. Usage

**!** IMPORTANT: Do not use the Carpet Cleaner as a dry vacuum.

**!** NOTE: Never leave unit unattended with power on. Turn OFF when emptying and filling reservoir. DO NOT oversaturate carpet or upholstery.

**!** IMPORTANT: For best cleaning results, use steady, moderate, forward and backward motion.

### Check for Colour Fastness:

Before cleaning carpet/upholstery, test for colour fastness. Dampen a white cloth with solution. Test a small area somewhere discreet i.e. underneath a cushion. Gently rub the cloth over the area. Check each colour for colour bleeding. If the cloth remains clean, it should be safe to clean the carpet/upholstery.

### Helpful Hints for Cleaning Carpet:

1. Do not oversaturate carpet with cleaning solution while using the Carpet Cleaner.
2. For heavily soiled areas, additional applications may be necessary.
3. Allow plenty of time to dry carpet thoroughly.
4. Wipe cleaning solution from woodwork and wood to prevent any damage.
5. Try not to walk on carpet until it is completely dry.
6. After carpet is thoroughly dry, vacuum the carpet using a cleaner with a revolving brushroll.

### Carpet and Upholstery Cleaning

Plug cord into electrical outlet (Fig.5/1).

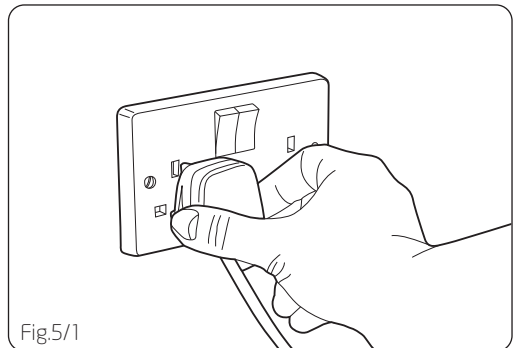
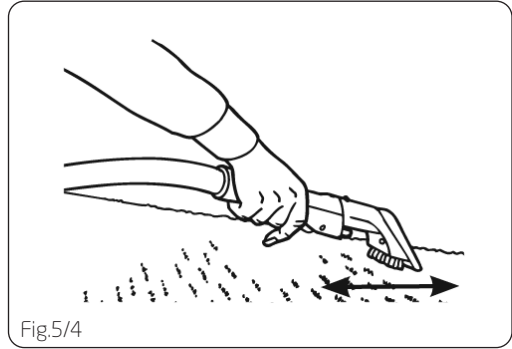
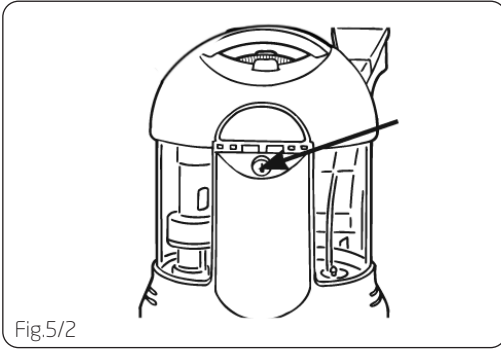

Fig.5/1

Turn ON/OFF switch to the "ON" position (Fig.5/2).



Hold the tool approximately 1" above the stained surface. Press the solution dispense trigger to apply cleaning solution to the stained area. NOTE: Before using hand tool attachments, it is necessary to prime the pump. Follow these steps for optimal performance: (Fig.5/3)

- Fill the clean water tank.
- Place hand tool attachment on floor.
- Depress the solution dispense button on hose for 10 seconds while the power is off.
- Repeat if necessary.

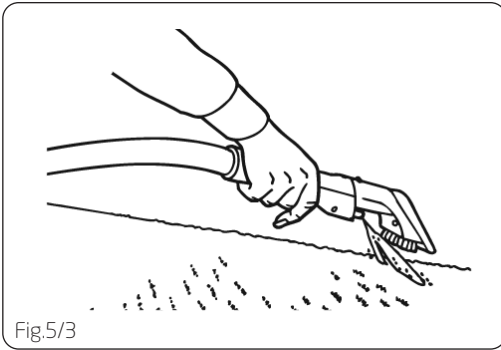

Gently scrub the stained area with the brush on the tool until the stain is completely removed. Release the solution dispense trigger and continue moving the tool over cleaned area to remove as much liquid as possible (Fig.5/4).

### Emptying and Cleaning the Dirty Water Tank

**⚠ WARNING:** To reduce risk of electric shock or injury, unplug before removing tank(s) and remove tanks from unit before emptying.

When to empty:

- Dirty water reaches the 'full' line on the dirty water tank - OR
- Float shuts off airflow, indicated by a change in pitch of the motor and reduced suction
- At the end of each use, prior to storage

Turn ON/OFF switch to the OFF position. Unplug power cord from outlet. Press down on the Lid Release Latch and tilt towards the front of cleaner to access the tanks (Fig.5/5).

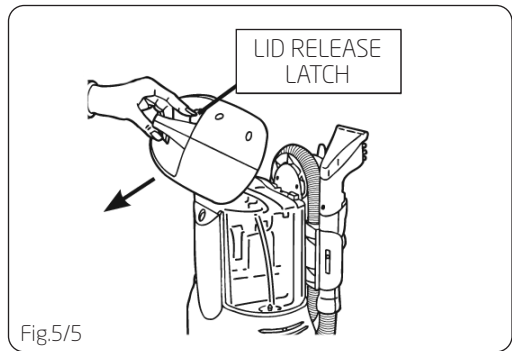

Remove Clean and Dirty Water Tank assembly by pulling up and out of cleaner and separate Dirty Water Tank (Fig.5/6).

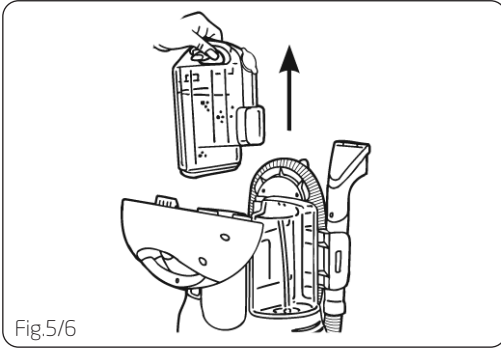

Fig.5/6

Open Dirty Water Tank plug and empty contents into sink (Fig.5/7).

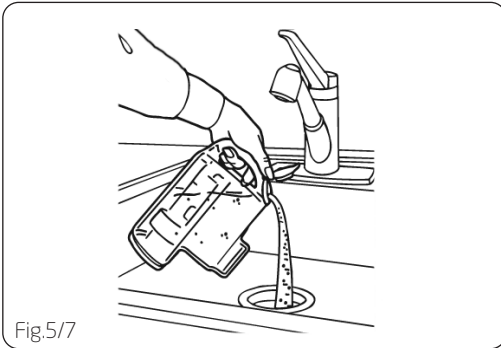

Fig.5/7

Rinse thoroughly with clean water (Fig.5/8).

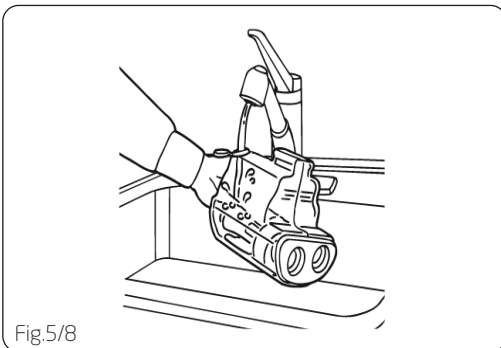

Fig.5/8

## 6. Troubleshooting

**! WARNING:** To reduce risk of personal injury, unplug carpet washer before servicing.

**PROBLEM:** The cleaner won't run

**Cause:** Power cord not firmly plugged into socket.

**Solution:** Plug cord in firmly.

**Cause:** Blown fuse/tripped breaker.

**Solution:** Check fuse or breaker in home. Replace fuse/reset breaker.

**PROBLEM:** Cleaner won't pick up or low suction

**Cause:** Dirty Water Tank is not installed correctly.

**Solution:** Review 'Usage' section of this user guide.

**Cause:** Dirty Water Tank is full.

**Solution:** Empty dirty water tank (for instructions see 'Usage' section of this user guide).

**Cause:** Incorrect cleaning tool position.

**Solution:** Reposition cleaning tool, following instructions from 'Usage' section of this user guide.

**Cause:** Incorrect cleaning solution.

**Solution:** Use only Vax AAA cleaning solution.

**PROBLEM:** Water escaping from cleaner

**Cause:** Dirty Water Tank is full.

**Solution:** Empty dirty water tank (for instructions see 'Usage' section of this user guide).

**Cause:** Dirty Water Tank is not installed correctly.

**Solution:** Review 'Usage' section of this user guide.

**Cause:** Clean Water Tank is not installed properly.

**Solution:** Review 'Preparing the Machine' section of this user guide.

**PROBLEM:** Cleaner won't dispense solution or is dispensing at a low rate

**Cause:** Spray nozzle clogged.

**Solution:** Remove all attachments and clean thoroughly.

**Cause:** Clean Water Tank is not installed properly.

**Solution:** Review 'Preparing the Machine' section of this user guide.

**Cause:** Solution pump needs priming.

**Solution:** It may be necessary to prime the pump - review 'Usage' section of this user guide, or elevate unit above nozzle by placing on tabletop.

## 7. UK Service & Help

**Vax Care 0870 1129 145** (UK only)

Monday-Friday 8.00am to 6.00pm

Saturday-Sunday 9.00am to 5.00pm

An answerphone is available outside of these hours. Any queries or concerns about using the Vax, call the Vax Careline. Calls are charged at the UK national rate.

Please make a note of the serial number and model number of the vacuum cleaner before calling. There are over 400 approved Vax Service Agents in the UK. For the nearest Service Agent, please call the Vax Careline.

[www.vax.co.uk](http://www.vax.co.uk)

## 8. Technical Specification

Voltage:	220V~240V-50Hz
Motor Power:	350 W
Clean water tank volume:	1.7 litres
Dirty water tank volume:	1 litre
Cord length:	10.0m
Weight:	5.4kg
Noise (IEC60704-2-1):	< 78dB (A)

Subject to technical change without notice.





This page has been left intentionally blank.

This page has been left intentionally blank.

This page has been left intentionally blank.

vax®

## EEC STATEMENT OF COMPLIANCE

Manufacturer/EEC importer: Vax Limited, hereby on our own responsibility, declare that the product VCW-02 Carpet Washer is manufactured in compliance with the following Directives:

**Safety:** 2006/95/EC Low Voltage Directive

**EMC:** 2004/108/EC Electromagnetic Compatibility Directive



Waste electrical products should not be disposed of with household waste. Please recycle where facilities exist. Check with your Local Authority or retailer for recycling advice.

Vax Ltd., Kingswood Road, Hampton Lovett, Droitwich, Worcestershire, WR9 0QH, UK  
email: [info@vax.co.uk](mailto:info@vax.co.uk) - website: [www.vax.co.uk](http://www.vax.co.uk)