



User Manual

Original instructions

VE 17P-EU

VE 17HDP-EU

VE 17DSP-EU

VE 17HSP-EU



Company information:
www.vipercleaning.eu
info-eu@vipercleaning.com

VF72309EU (1) – 2012-04-10



TABLE OF CONTENTS

INTRODUCTION	4
MANUAL PURPOSE AND CONTENTS	4
TARGET	4
HOW TO KEEP THIS MANUAL	4
DECLARATION OF CONFORMITY	4
IDENTIFICATION DATA	4
OTHER REFERENCE MANUALS	4
SPARE PARTS AND MAINTENANCE	4
CHANGES AND IMPROVEMENTS	4
PURPOSE AND INTENDED USE	4
CONVENTIONS	5
UNPACKING/DELIVERY	5
SAFETY	5
SYMBOLS USED TO MARK INSTRUCTIONS	5
GENERAL INSTRUCTIONS	5
MACHINE DESCRIPTION	8
MACHINE STRUCTURE	8
TECHNICAL DATA	9
WIRING DIAGRAM FOR VE17P-EU VE17HDP-EU VE17HSP-EU	9
WIRING DIAGRAM FOR VE17DSP-EU	9
OPERATION	10
BEFORE STARTING THE MACHINE	10
ASSEMBLY	10
TRANSPORT	10
BASIC OPERATION	10
MAINTENANCE	11
STORAGE	11
RECYCLING THE CLEANER	11

INTRODUCTION



NOTE

The numbers in brackets refer to the components shown in Machine Description chapter.

MANUAL PURPOSE AND CONTENTS

The purpose of this Manual is to provide the operator with all necessary information to use the machine properly, in a safe and autonomous way. It contains information about technical data, safety, operation, storage, maintenance, spare parts and disposal. Before performing any procedure on the machine, the operators and qualified technicians must read this manual carefully. Contact Viper in case of doubts concerning the interpretation of the instructions and for any further information.

TARGET

This manual is intended for operators and technicians qualified to perform the machine maintenance.

The operators must not perform procedures reserved for qualified technicians. Viper will not be answerable for damages coming from the non-observance of this prohibition.

HOW TO KEEP THIS MANUAL

The User Manual must be kept near the machine, inside an adequate case, away from liquids and other substances that can cause damage to it.

DECLARATION OF CONFORMITY

The declaration of conformity, supplied with the machine, certifies the machine conformity with the law in force.



NOTE

Two copies of the original declaration of conformity are provided together with the machine documentation. The CE-declaration is printed in the Quick Start Guide.

IDENTIFICATION DATA

The machine model and serial number are marked on the plate.

This information is useful when requiring machine spare parts. Use the following table to write down the machine identification data.

MACHINE model
MACHINE serial number

OTHER REFERENCE MANUALS

- Service Manual (can be consulted at Viper Service Centers)
- Spare Parts List (see www.vipercleaning.eu)

SPARE PARTS AND MAINTENANCE

All necessary operating, maintenance and repair procedures must be performed out by qualified personnel or by Viper Service Centers. Only original spare parts and accessories must be used. Contact Viper for service or to order spare parts and accessories, specifying the machine model and serial number.

CHANGES AND IMPROVEMENTS

Viper constantly improves its products and reserves the right to make changes and improvements at its discretion without being obliged to apply such benefits to the machines that were previously sold.

Any change and/or addition of accessories must be approved and performed by Viper.

PURPOSE AND INTENDED USE

All single-disc cleaners are designed to clean and care for floor coverings inside buildings only.

This appliance is suitable for commercial use, for example in hotels, schools, hospitals, factories, shops, offices and rental businesses.

Any other use is considered as improper use. The manufacturer accepts no liability for any damage resulting from such use. The risk for such use is borne solely by the user.

Proper use also includes proper operation, servicing and repairs as specified by the manufacturer.

CONVENTIONS

Forward, backward, front, rear, left or right and up are intended with reference to the operator's position, that is to say in working position with the handle.

UNPACKING/DELIVERY

To unpack the machine, carefully follow the instructions on the packing.





When the machine is delivered, check that the packing and the machine were not damaged during transportation. In case of visible damages, keep the packing and have it checked by the carrier that delivered it. Call the carrier immediately to fill in a damage claim.

SAFETY

The following symbols indicate potentially dangerous situations. Always read this information carefully and take all necessary precautions to safeguard people and property.

The operator's cooperation is essential in order to prevent injury. No accident prevention program is effective without the total cooperation of the person responsible for the machine operation. Most of the accidents that may occur in a factory, while working or moving around, are caused by failure to comply with the simplest rules for exercising prudence. A careful and prudent operator is the best guarantee against accidents and is essential for successful completion of any prevention program.

SYMBOLS USED TO MARK INSTRUCTIONS

	DANGER! Danger that leads directly to serious or irreversible injuries, or even death.
	WARNING! Danger that can lead to serious injuries or even death.
	CAUTION! Danger that can lead to minor injuries and damage.
	NOTE Indicates a remark related to important or useful functions.

GENERAL INSTRUCTIONS

Specific warnings and cautions to inform about potential damages to people and machine are shown below.

The appliance must

- only be used by persons, who have been instructed in its correct usage and explicitly commissioned with the task of operating it
- only be operated under supervision
- not be used by children

The workplace is behind the cleaner.

Do not use any unsafe work techniques.

Always guide the cleaner with both hands on the handle.

When the cleaner is stationary, switch off the brush unit immediately to prevent damage to the floor covering.

Switch off the appliance and disconnect the mains plug in the following situations:

- Prior to cleaning and servicing
- Prior to replacing components
- Prior to changing over the appliance

Use of the cleaner is subject to current national regulations. Besides the operating instructions and binding accident prevention regulations valid in the country of use, observe recognized regulations for safe and proper work.

TRANSPORT

When transporting the cleaner in elevators

- observe current safety regulations, in particular with regard to carrying capacity.
- place the shaft in an upright position to prevent it from catching on elevator shaft walls.

OPERATION

The machine working temperature must be between 0°C and +40°C.

The humidity must be between 30% and 95%.

Do not use the machine as a means of transport.

In case of fire, use a powder fire extinguisher, not a water one.

Do not tamper with the machine safety guards and follow the ordinary maintenance instructions scrupulously.

Do not allow any object to enter into the openings. Do not use the machine if the openings are clogged. Always keep the openings free from dust, hairs and any other foreign material which could reduce the air flow.

Do not remove or modify the plates affixed to the machine.

If the machine is used according to the instructions, the vibrations are not dangerous. The machine vibration level is less than 2.5 m/s² (98/37/EEC-EN 1033/1995).

This machine must not be used on roads or public streets.

Viper machines can be used in combination with standard detergents which cannot damage any materials of Viper machines (no use of solvents or other aggressive liquid materials). Viper will not pay any claims regarding using aggressive detergents in Viper machines. If you need a special detergent for cleaning purposes, please contact your Viper dealer.

Pay attention during machine transportation when temperature is below freezing point. The water in the tank or in the hoses could freeze and seriously damage the machine.

MAINTENANCE

To ensure machine proper and safe operation, the scheduled maintenance shown in the relevant chapter of this manual, must be performed by the authorised personnel or by Viper Service Center.

Carefully read all the instructions before performing any maintenance/repair procedure.

Do not wash the machine with direct or pressurised water jets, or with corrosive substances.

GUARANTEE

Our general conditions of business are applicable with regard to the guarantee.

Unauthorised modifications to the appliance, the use of incorrect brushes and detergents in addition to using the appliance in a way other than for the intended purpose exempt the manufacturer from any liability for the resulting damage.

TESTS AND APPROVALS

Electrical tests must be performed in accordance with the provisions of safety regulations (BGV A3) and to DIN VDE 0701 Part 1 and Part 3. In accordance with DIN VDE 0702 these tests must be performed at regular intervals and after repairs or modifications.

ELECTRICAL COMPONENTS



DANGER

Electric shock due to faulty mains connecting lead.

Touching a faulty mains connecting lead can result in serious or even fatal injuries.

- ▶ Do not damage the mains power lead (e.g. by driving over it, pulling or crushing it).
- ▶ Regularly check whether the power cord is damaged or shows signs of ageing.
- ▶ Have the faulty mains connecting lead replaced by your Viper service representative or a qualified electrician prior to using the appliance again.



CAUTION

Electrical components.

Damage due to unsuitable mains voltage.

The appliance can be damaged as a result of being connected to an unsuitable mains voltage.

- ▶ Ensure that the voltage shown on the rating plate corresponds to the voltage of the local mains power supply.



CAUTION

Electrical connection.

- ▶ Connect the appliance via a residual current circuit breaker.
- ▶ Arrange the electrical parts (sockets, plugs and couplings) and lay down the extension lead so that the protection class is maintained.
- ▶ Connectors and couplings of power supply cords and extension leads must be watertight.

STAIRS AND GRADIENTS



CAUTION

Risk of tipping and slipping on stairs and gradients.

When negotiating stairs and gradients, there is a risk of personal injuries and damage to property.

- ▶ Do not negotiate steps.
- ▶ Only use the appliance on level surfaces with a maximum gradient of 2 %.

FLOOR COVERINGS**CAUTION**

Damage to sensitive floor coverings.

Particularly sensitive floor coverings can be damaged by cleaning.

- ▶ Before using the cleaner, check whether floor coverings are suitable for this cleaning technique.
- ▶ Beware of area compression in point-elastic floors, e.g. in gym halls.
- ▶ Only use cleaning agents approved by Viper.

MATERIALS HAZARDOUS TO HEALTH**WARNING**

Materials hazardous to health in floor coverings.

Floor coverings can contain materials that are hazardous to health, which dissolve during cleaning.

- ▶ Do not clean floor coverings from which dusts or liquids that are hazardous to health can dissolve.

RISK OF EXPLOSION**WARNING**

Flammable and explosive materials.

Risk of explosion in explosive atmosphere or areas where flammable and explosive materials are stored.

- ▶ Do not operate the machine near dangerous, flammable and/or explosive powders, liquids or vapours.

SPARE PARTS AND ACCESSORIES**CAUTION**

Non-genuine components and unsuitable detergents.

The use of non-genuine parts and unsuitable detergents can impair the safety of the appliance and lead to damage.

- ▶ Only use spare parts and accessories from Viper.
- ▶ Only use the accessories and detergents supplied with the appliance or those specified in the operating instructions.

MACHINE DESCRIPTION

MACHINE STRUCTURE

- | | |
|---|-----------------------------|
| (1) Guide Handle | (11) Motor Cover |
| (2) Switch Lever, Right | (12) Power Cord |
| (3) Adjustment Lever | (13) Strain Relief |
| (4) Shaft | (14) Lever Solution |
| (5) Cord Wrap | (15) Switch Lever, Left |
| (6) Switch Plug (VE17P-EU, VE17HDP-EU, VE17HSP-EU),
Switch(H/L speed) (VE17DSP-EU) | (16) Button interlock |
| (7) Wheel | (17) Pad Driver |
| (8) Barb Hose | (18) Pad |
| (9) Bumper | (19) Brush |
| (10) Mainframe | (20) Solution tank assembly |

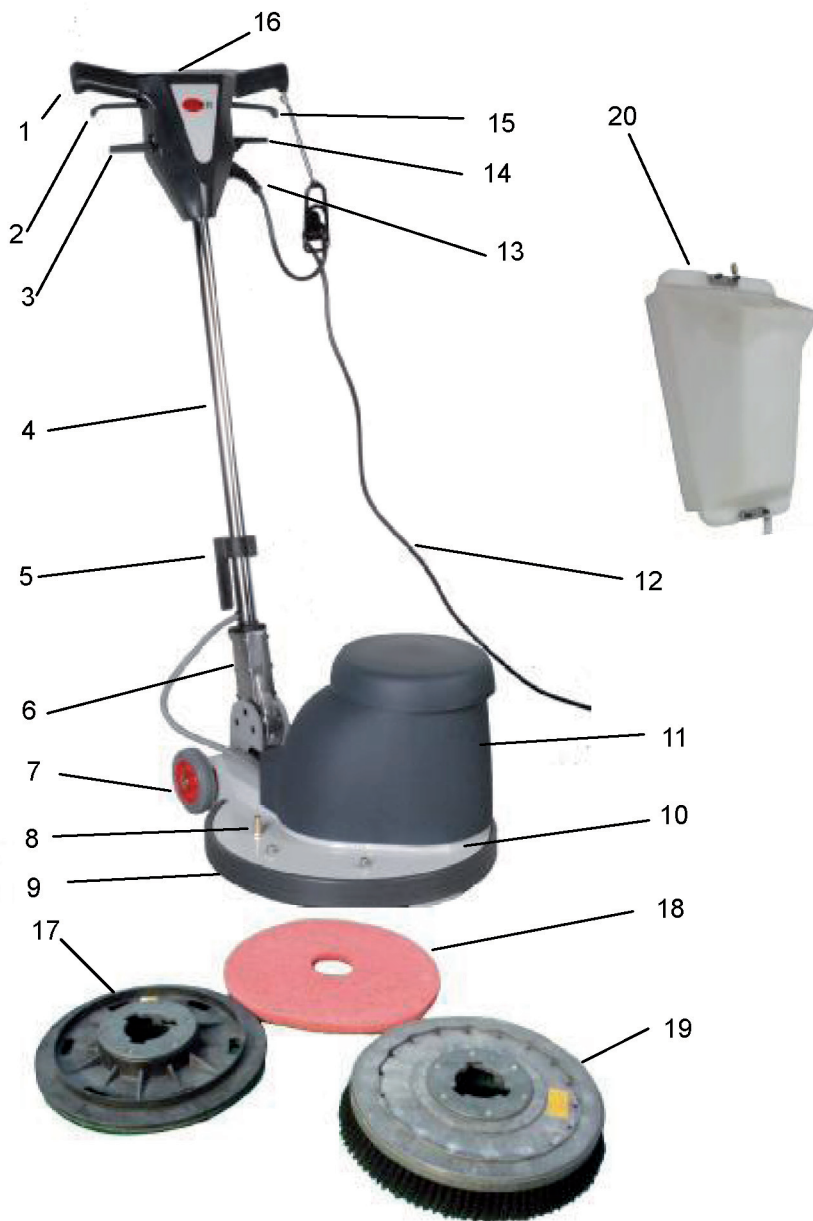

TECHNICAL DATA

Model		VE17P-EU	VE17HDP-EU	VE17DSP-EU	VE17HSP-EU
Voltage	V	220 – 240	220 – 240	220 – 240	220 – 240
Power	W	750	1120	1125/1500	1500
Current	A	4.6	7	7.2/9.5	9.8
Frequency	Hz	50-60	50-60	50-60	50-60
Brush Speed	rpm	150	150	150/300	300
Brush Diameter	cm	43.2	43.2	43.2	43.2
Dimension LxWxH	cm	53.6 x 43.2 x 121.9	53.6 x 43.2 x 121.9	53.6 x 43.2 x 121.9	53.6 x 43.2 x 121.9
Weight	kg	43	45	46	45
Length of Power cord	m	15	15	15	15
Sound pressure level	dB(A)	< 85	< 85	< 85	< 85

WIRING DIAGRAM FOR VE17P-EU VE17HDP-EU VE17HSP-EU

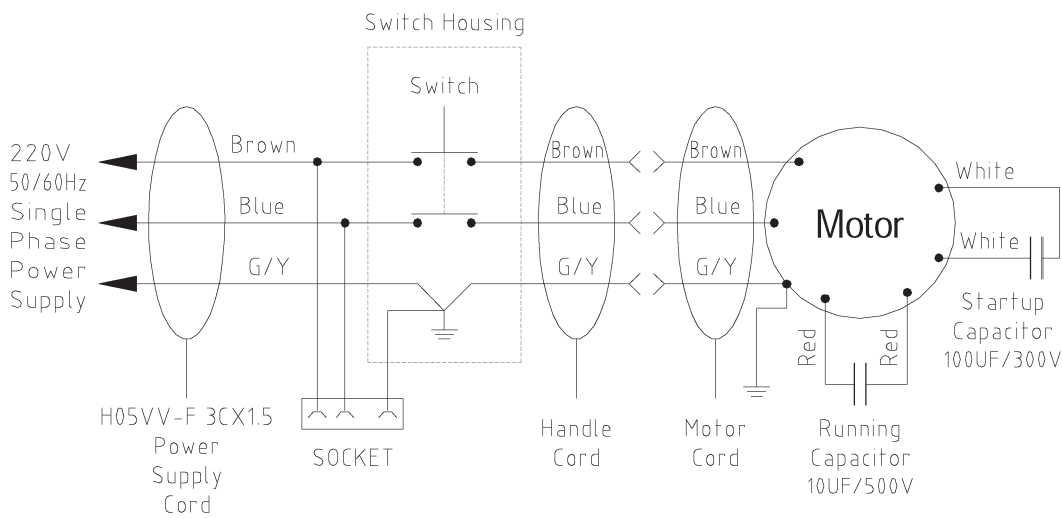

WIRING DIAGRAM FOR VE17DSP-EU

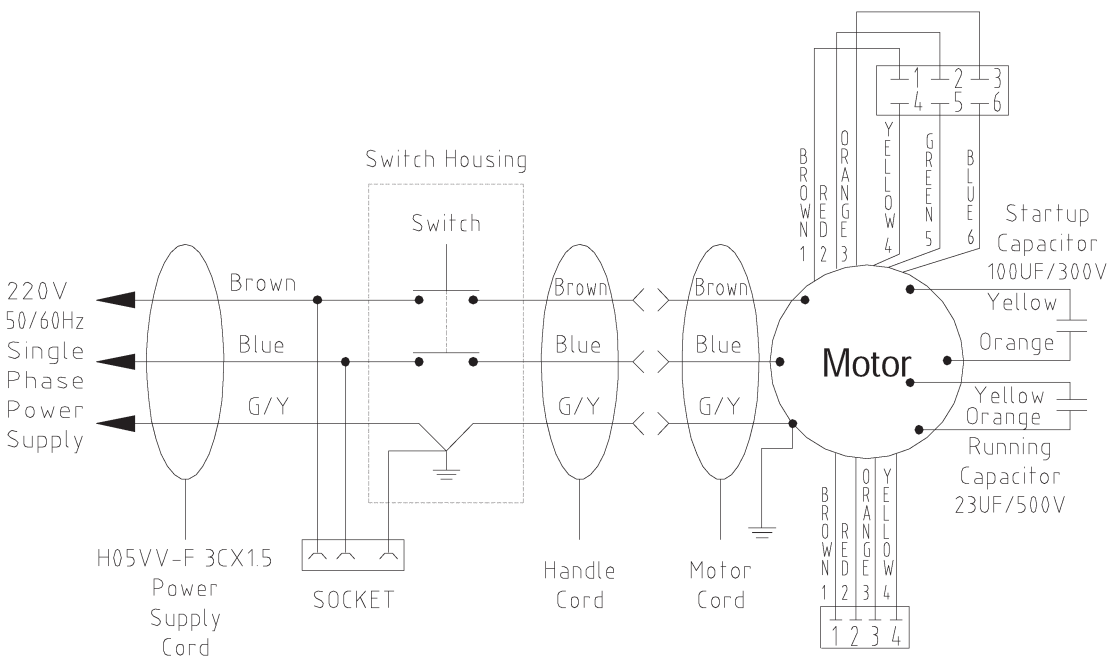

Single Phase Power Supply	<i>insert translation</i>	Motor	<i>insert translation</i>
Power Supply Cord	<i>insert translation</i>	Brown	<i>insert translation</i>
Switch Housing	<i>insert translation</i>	Blue	<i>insert translation</i>
Switch	<i>insert translation</i>	G/Y	<i>insert translation</i>

Socket	<i>insert translation</i>	Black	<i>insert translation</i>
Handle Cord	<i>insert translation</i>	Red	<i>insert translation</i>
Motor Cord	<i>insert translation</i>	White	<i>insert translation</i>
Running Capacitor	<i>insert translation</i>	Orange	<i>insert translation</i>
Starting Capacitor	<i>insert translation</i>	Yellow	<i>insert translation</i>
		Green	<i>insert translation</i>

OPERATION

BEFORE STARTING THE MACHINE

ASSEMBLY

For transport reasons the motor head and shaft are supplied not assembled.

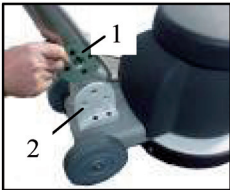

- ▶ Insert the gear index housing (1) into the “U” shape bracket (2).



- ▶ Align the holes of the gear index housing and the “U” shape bracket.
- ▶ Insert the socket screws into the holes of the “U” shape bracket and then tighten the screws.

- ▶ Wind the power cord around the handle and the power cord hook.

TRANSPORT

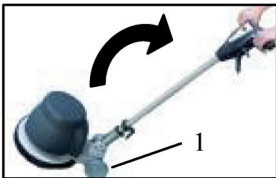

- ▶ Place the handle in the upright position, Grasp the handle with both hands and tip the machine until it stands on the two wheels (1).
- ▶ Wheel the machine to where it is needed.

BASIC OPERATION



- ▶ Remove any obstructions or other obstacles in the area which is to be cleaned.
- ▶ Place the handle in the upright position and tilt machine back until handle rests on the floor.



NOTE

Be sure the machine is not plugged into an outlet.

- ▶ Attach the pad driver or brush to the machine by placing the clutch plate over the gearbox hub and turning the driver / brush 1/4 turn.
- ▶ Place machine back into its upright position.
- ▶ Plug power cord into a grounded outlet.



NOTE

Never use an extension cord in conjunction with the standard power cord.

- ▶ The handle height may be adjusted by pulling the adjustment lever (1) and lower the shaft (2) into its cleaning position.
- ▶ To start the machine, press the red safety button (3) on the top of the upper switch housing ,and then squeeze either of the operating triggers(4/5) the safety button (3) must be de-pressed prior to squeezing the operating triggers (4/5).

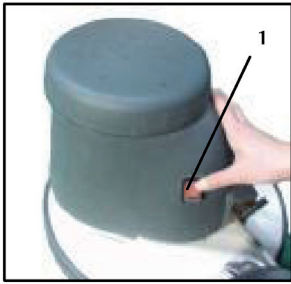
**NOTE**

Never change the speed while operating the machine. Be sure the power is turned off prior to changing the speed.

- ▶ Select either low speed {150 rpm} or high speed {300 rpm} by pushing the motor mounted switch (1) into the low or high position (Only for VE17DS).

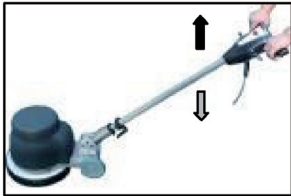

- ▶ When the machine is in operation, both hands should be placed on the switch housing {upper handle}.
- ▶ During operation, to make the machine go right, gently raise the handle. To make the machine go left, gently lower the handle.
- ▶ To stop the machine at any time, simply release the operating trigger and the machine will stop automatically.
- ▶ Unplug machine as soon as you are not using it.
- ▶ Tilt machine back and remove pad driver or brush.
- ▶ Roll the power cord around the handle and the power cord hook.

MAINTENANCE

To keep the machine performing well for many years, please follow the following maintenance procedures.

**CAUTION!**

Always confirm that the machine is unplugged prior to performing any maintenance or repairs.

**NOTE**

Never store a single disc machine with the pad driver or brush mounted to the machine.

- ▶ Unplug machine as soon as you are not using it.
- ▶ Clean the outside of the machine with a mild cleaner.
- ▶ Check power cord for any damage. If damage is detected, replace power cord immediately.
- ▶ Lubricate wheels with a water resistant lubricant once a month.
- ▶ Check machine for loose or missing nuts and bolts, and replace as necessary.
- ▶ If the machine is used in a dusty environment, you may remove the motor cover and blow the motor, clean with compressed air. This will ensure proper ventilation, and allow the motor to run cooler.

STORAGE

- ▶ Unplug machine from power source.
- ▶ Store the appliance in a dry place, protected from frost.
- ▶ The machine storage temperature must be between 0°C and +40°C.

RECYCLING THE CLEANER

Make the old cleaner unusable immediately:

- ▶ Unplug the cleaner.
- ▶ Cut the power cord.
- ▶ Do not discard of electrical appliances with household waste.



As specified in European Directive 2002/96/EC on old electrical and electronic appliances, used electrical goods must be collected separately and recycled ecologically. Contact your local authorities or your nearest dealer for further information.

Company information:
www.vipercleaning.eu
info-eu@vipercleaning.com

