



HEADPHONE AMPLIFIER

HPA V90



USER'S MANUAL

Content

Theme	Page
About Vioelectric	3
Safety Instructions	5
The Earth / Grounding Concept	7
Connection / Connectors	9
General	10
Operation	11
Special Functions	15
Things to know	16
Disposal	20
Technical Data	21
Jumper Setting	22
Conformity Statement	23
Warranty	24

CAUTION !!

**THE HIGH OUTPUT LEVELS ACHIEVABLE
WITH THIS UNIT MAY
DAMAGE YOUR HEARING OR THE HEADPHONES
IF OPERATED CARELESSLY !!**

Cordial thanks for your decision in favour of a

VIOLECTRIC product !

VIOLECTRIC is a trademark and product line of Lake People electronic GmbH. Lake People electronic GmbH develops, manufactures and distributes products in the professional range, for broadcast, television, airports, exhibition halls, festival venues, theatres, large-scale installations, private studios and more. In the private sector as well, Lake People products become increasingly popular due to their outstanding quality.

The **VIOLECTRIC** trademark and product line is specially intended to supply the Hi-Fi and High-End market with its specific requirements.

Who develops **VIOLECTRIC equipment ?**

VIOLECTRIC devices are exclusively developed in Germany by the engineers of Lake People electronic GmbH. In doing so, the team of developers can draw on twenty years of experience and countless products for the pro-audio domain.

Among others, the first German-made 20-bit A/D and D/A converters were developed by Lake People in the early nineties of the past century.

Who manufactures **VIOLECTRIC equipment ?**

VIOLECTRIC devices are exclusively manufactured in Germany by Lake People electronic GmbH or contractors in the company's vicinity.

Lake People - and by association **VIOLECTRIC** - put high emphasis on domestic manufacturing. As well, all component suppliers are chosen in order to achieve the main part of added value inland.

How do **VIOLECTRIC** devices get to the customer ?

VIOLECTRIC devices can be obtained from respective specialist suppliers. If there is none such accessible regionally, the customer is supported by transregional distribution partners (google may help...) and, of course, by Lake People electronic GmbH themselves.

... and if it doesn't work like it should ?

VIOLECTRIC devices are covered by a 24-month warranty. In case of any malfunction during this period, they can be shipped to the manufacturer directly. Of course, the client will benefit from **VIOLECTRIC**'s and Lake People's full technical support even when warranty has expired. Any technical questions or need for advice is welcome.



is a subsidiary of



LAKE PEOPLE

LAKE PEOPLE electronic GmbH
Turmstrasse 7a
D-78467 Konstanz

Fon +49 (0) 7531 73678

Fax +49 (0) 7531 74998

www.vioelectric.de www.vioelectric.com
www.lake-people.de www.lake-people.com

General Safety Instructions

WARNING

For your protection, please read the following:

Water, Liquids, Moisture:

This appliance should not be used near water or other sources of liquids. Care should be taken so that objects do not fall and liquids are not spilled into the enclosure through openings.

Power Sources:

The appliance should be connected to a power supply only of the type described in the operating instructions or as marked on the appliance.

Grounding:

Care should be taken that this appliance is operated with proper grounding only.

Power Cord:

Power supply cords should be routed so that they are not likely to be walked on or pinched by items placed upon or against them, paying particular attention to cords at plugs, convenience receptacles, and the point where they exit from the appliance.

This unit is equipped with a 3-pole mains cable with German 3-pin mains plug. In some countries this unit must be operated with a mains adaptor, supplied by the owner.

Please refer to the table below to connect a mains plug:

OVERVIEW: POWER CORD FUNCTION AND COLORS			
CONDUCTOR		COLOR	Alternativ
L	LIVE	BROWN	BLACK
N	NEUTRAL	BLUE	WHITE
E 	PROTECTIVE EARTH	GREEN+YELLOW	GREEN

U.K. Mains Plug Warning:

A moulded mains plug that has been cut off from the cord is unsafe. Discard the mains plug at a suitable disposal facility.

NEVER UNDER ANY CIRCUMSTANCES SHOULD YOU INSERT A DAMAGED OR CUT MAINS PLUG INTO A 13 AMP POWER SOCKET. Do not use the mains plug without the fuse cover in place. Replacement fuse covers can be obtained from your local retailer. Replacement fuses are 13 amps and **MUST** be ASTA approved to BS 1362.

Mains Fuse:

The mains fuse of this appliance is soldered in place and accessible from the inside only!!

A blown fuse may indicate an internal problem and should be replaced during qualified servicing or repair work !!

Switchable Power Supply:

Connect this unit to the power source indicated on the equipment rear panel only to ensure safe operation !!

This unit is provided with an internally settable mains supply for 115 / 230 V AC.

Service / Repair:

To reduce the risk of fire or electric shock, the user should not attempt to service the appliance beyond the measures described in the operating manual. All other servicing or repair should be referred to qualified personnel !!

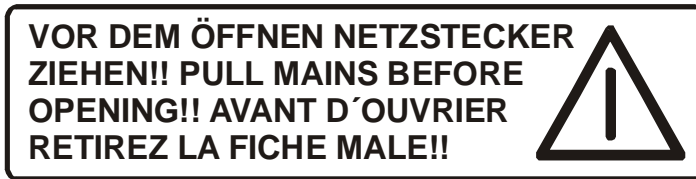
**Electromagnetic Compatibility**

This unit conforms to the Product Specifications noted as **Declaration of Conformity** at the end of this manual. Operation is subject to the following conditions:

- this device may not cause harmful interferences
- this device must accept any interference received, including interference that may cause undesired operation
- this device must not be operated within significant electromagnetic field

The Earth / Grounding Concept

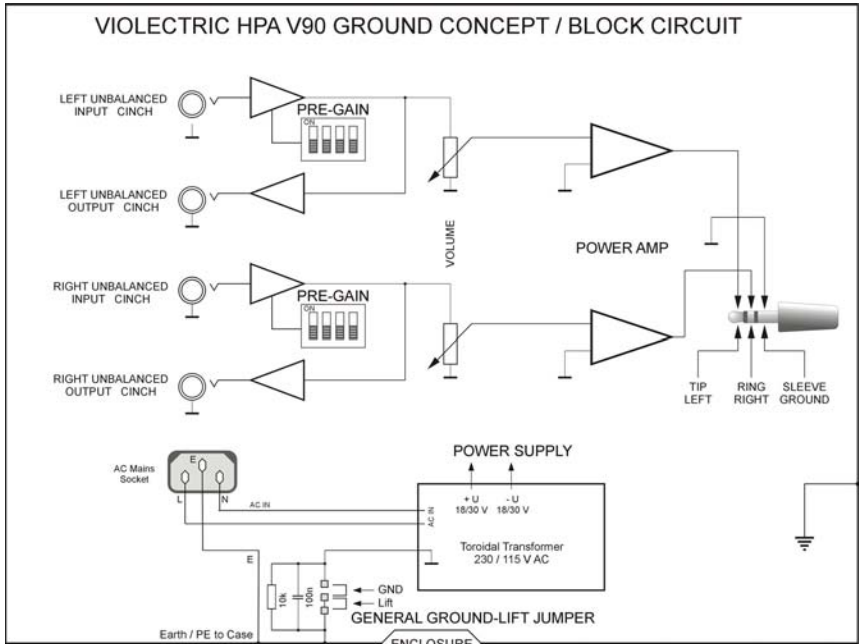

**General GROUND-LIFT Jumper (accessible from the inside.
Mind the SECURITY INSTRUCTIONS !!):**

Ex-works this jumper is set to the **LIFT** position.

The internal ground potential is "lifted" by means of this jumper.

As a result, the interconnection for DC voltages and lower frequencies (< 150 Hz) will be cut. Higher frequencies will be bled off to earth potential through the RC filter. The LIFT position is helpful in case of hum or jitter caused by different ground/earth potentials.

Of course full electrical protection is guaranteed as the case is always connected to ground/earth potential !

Unfortunately there is no general recommendation how to solve hum and jitter problems - or even minimize them. The best way to succeed is to check different options !!

Electrical safety is always ensured, since the earth conductor is permanently connected to the enclosure !!

**Please note that with jumpers not in the ex-works position
EMC emission might occur,
for which the user is responsible only !**

Connection / Connectors for Analog Signals

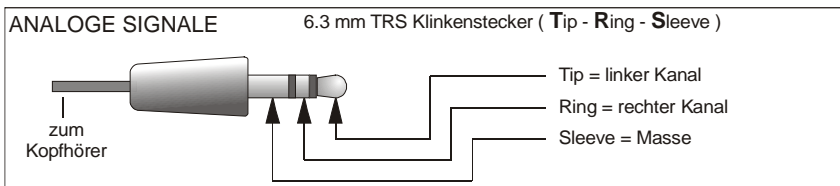
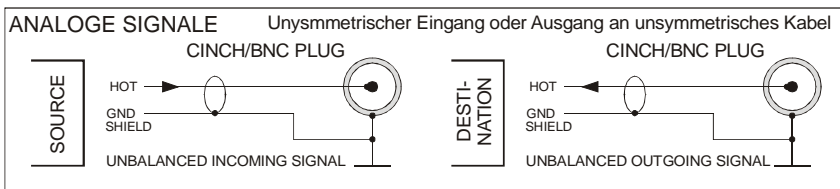

GENERAL INFORMATION

The HPA V90 is a stereophonic headphone amplifier designed to drive low-, medium- and high-Z loads (16...600 ohms) as usually represented by high-quality headphones. Due to its specific, variable and low-noise and distortion circuit design especially optimised for dynamic headphones, the HPA V90 fulfils even highest demands.

Features:

- Unbalanced inputs with gold-plated ALPS cinch connectors
- Unbalanced outputs with gold-plated ALPS cinch connectors
- **PRE-GAIN** = switchable input gain in five steps
- Independent-channel design
- DC-coupled (switchable)
- ALPS RK14 volume control
- High-Quality op-amps in the signal path
- High-quality MKP capacitors in the signal path
- 1% metal film resistors throughout the unit
- 2 silver-plated Neutrik headphone outputs
- Relay-based headphone output cutoff
- Toroidal transformer
- Large filtering capacitors in the power supply
- Switchable ground lift
- Rugged aluminium case with Nextel coating
- Solid, laser-engraved aluminium front panel

With its small dimensions, the HPA V90 ensures optimum flexibility combined with high output power. During design, high emphasis was put on operational safety even when the unit is operated inappropriately. The HPA V90 is equipped with internal filters to prevent damage to the connected headphones due to high-frequency overload beyond the audible range.

THE CASE

The HPA V90's case as well as the front/rear panels are made of solid aluminium. This choice of material ensures high mechanical stability and resistance.

EARTH AND GROUND

The HPA V90's case is grounded. Internal reference ground is bridged to protective earth by means of a jumper. If required, the jumper can be set to 'LIFT' position (see also: page 7 "Earth/Ground concept", page 22 "Technical Appendix").

POWER SUPPLY

Mains power is provided via a three-pin IEC/CEE socket and mating "cold-appliance" mains cord with Schuko-type plug. The device is set to 230V mains, whereas the actual voltage may vary between 190 and 240 volts for flawless operation. A toroidal transformer provides the internal operating voltages of +/-30V approx.

MAINS FUSE

The 0.25A time-lag fuse is soldered in place on the circuit board. In case, it must be replaced with a fuse of the same type only.

CAUTION !!

MIND THE SAFETY INSTRUCTIONS:

A blown fuse indicates an internal fault and should be replaced during qualified repair or servicing only !!



THE INPUTS

For the use with unbalanced signals, gold plated cinch sockets are provided. They are labelled as "LEFT IN" and "RIGHT IN".

Input impedance is 10 kohms.

Maximum input level should not exceed +21 dBu.

This value is reduced to +15/+9 dBu if **PRE-GAIN** is set to +6/+12 dB !!

THE ACTIVE FEED-THROUGH

Your HPA V90 offers the opportunity of having dedicated outputs for the refreshed input signals which can so be used for further purposes.

The gold plated cinch outputs are marked as "LEFT OUT" and "RIGHT OUT".

Output levels equal the levels applied to the inputs, i.e. the signal is amplified by 0dB (unity gain) at an output impedance of < 30 ohms.

Too loud ? Too soft ? The PRE-GAIN method

The V90 is specially designed to drive headphones. Headphones however can present load impedances from 8 to 2000 ohms and efficiency ratios from 85 to 115dB per milliwatt. Thus it can be quite tricky to fulfil all demands, since...



... owners of high-effectivity headphones will rarely set the volume control higher than 9 o'clock in order to exclude hearing damage, while ... the maximum setting may still be too soft for low-efficiency headphones, but

... all users expect highest quality at lowest noise and distortion. Thus, the *circuitry* must adapt itself as the headphone won't !

WE CALL THE SOLUTION TO THIS PROBLEM **PRE-GAIN**

The alignment between amplifier and headphone is provided by the preamp stage, which can boost or attenuate the input signal in four steps of 6dB each. For this purpose, two switching devices are located on the rear panel for left and right channel individually.

CAUTION !!

The switch settings should be altered under the following conditions only:

- The unit must be switched OFF
- the "VOLUME" control must be set to minimum
- left and right channel should ALWAYS be set the same
- never increase the setting by more than ONE step per channel at a time.

If volume could be somewhat softer (in order to improve volume control range e.g.), push the switch labelled "-6dB" (half gain) or "-12dB" (quarter gain) in upward direction.

If you find your HPA V90 should provide more gain, do so with the switch labelled "+6 dB" (double gain) or "+12 dB" (quadruple gain).

Ex-factory, all switches are set to their lowest position - i.e. 0 dB or unity gain - which should be sufficient for most applications.



OPERATION

Most control elements and indicators are located on the front panel.

POWER SWITCH

The unit is put into operation by means of the power switch. Power-on status is indicated by the blue LED below.



VOLUME CONTROL

The "VOLUME" control sets the desired output volumes for left and right channel simultaneously.

THE AMPLIFIERS

The input signals are fed to very special noiseless high-power integrated amplifiers which are capable to be operated with high supply voltage. The individual-channel design provides optimum crosstalk rejection. The amplifier's frequency range stretches from DC to over 200kHz (-3dB cutoff frequency) in order to obtain absolutely linear characteristics within the audible range. Overall gain is set to +8 dB in order to provide sufficient reserves also for high-impedance headphones.

THE HEADPHONE OUTPUTS

The HPA V90 offers two stereophonic headphone outputs, each equipped with a 1/4" (6.3mm) jack socket.

Headphone socket pinout:	
TIP	Left channel
RING	Right channel
SLEEVE	GND

Special functions

Please note:

In the following, the internal settings of the HPA V90 are discussed. For changing these, a TORX T10 screwdriver is required and you should by all means

PULL THE MAINS PLUG !!!

Only thereafter the settings can be altered without any hazard.

Frequency bandwidth limiting

Your HPA V90's upper frequency limit is 200 kHz - the so-called "3-dB point" - at which signal level drops by 3dB. This limit is high enough to exclude any effect on the audible spectrum on the one hand, but low enough to provide sufficient rejection of possible radio-frequency interference.

Towards the low end, your HPA V90's frequency response is not restricted at all. This means that even extremely low frequencies - right down to DC - will be amplified. "DC-coupling" as this technique is called, is not necessarily useful since neither DC nor very low frequencies are audible, but may damage your headphones on the other hand.

Therefore, the HPA V90 offers a low-frequency limiting option as well. For this purpose, the two "LO-CUT" jumpers to the left and right of the "VOLUME" control can be swapped from "DC" to "AC" position. When set to "AC", low frequency response is limited to 12Hz, again referred to the "3-dB point".

See also: technical appendix, page 22.

Ex-works, the HPA V90 is set to "AC" response (12Hz).

Things to know ...

The HPA V90 offers unbalanced inputs. The input signals are fed to buffer amplifiers - for left and right channel separately - which also provide the PRE-GAIN setting.

Your HPA V90 also offers an active feed-throu with dedicated buffering amplifiers. This helps to use the input signals for further purposes.

Why does an active feed-through make sense ?

Each electronic device presents input impedance as well as input capacitance. If several devices would be coupled passively - e.g. with "Y" adapters - the resulting input parameters could provoke malfunction and instabilities. A buffer amplifier "reconditions" the signal and makes it compatible with other devices due to its low-impedance output.

Why are discrete signal paths important ?

Twin op-amps are the most common design for operational amplifiers, i.e. two amplifier circuits are integrated in one device. If left- and right-channel signals are processed simultaneously by such a device, interaction between both cannot be excluded. This interaction is admittedly diminutive, but should be avoided whenever a different design offers the possibility.

Why are op-amps ideal for low-level signal processing ?

Discrete amplifiers (designed with transistors) are very popular in high-end audio design also for preamplifier stages. This is often marketed as an optimization measure, but the partially exorbitant extra expenses are of course to be paid by the customer. But an op-amp consists of transistors as well...

Moreover, its structure has the advantage of thermal coupling between its internal components. Also ageing issues play a much less important role. Due to the large number of op-amps types offered, it is possible to pick an optimum type for any specific application.

Why does PRE-GAIN make sense ?

Two extreme examples (with the HPA V90 at 8dB gain, volume control set to full):

1st example:

The (pre-)amplifier provides 4V output voltage, whereas the headphone requires only 2V for 100dB sound pressure level.

With the control fully turned up, the V90 would deliver 10V output at 8dB gain. Therefore the volume control would have to be operated very carefully in order to avoid hearing damage. Moreover, any interference at the input should be avoided since it would be "unforgivingly" amplified as well. With PRE-GAIN, the input level can be reduced by 12dB (a fourth), with 1V instead of 4V as the result. This 1V is again amplified by 2.5, then equalling 2.5V. Now the volume control can be turned over almost the entire range.

2nd example::

The (pre-)amplifier provides 1V, whereas the headphone requires 20V to release 100dB of sound pressure.

With the volume control fully clockwise, the V90 would provide 2.5V at 8dB gain only - much too low for the headphone. By means of PRE-GAIN, input level can be boosted by 12dB (four times), resulting in effective 4V. These are again multiplied by 2.5, now equalling 10V. This is still not enough, but far closer to the optimum value: The headphone achieves 114dB sound pressure level.

The HPA V90 is DC-coupled, i.e. it can transduce DC voltage as well. For good measure, a low-cut filter can be inserted by setting the corresponding jumpers. After input buffering, the signals are forwarded to a simple 6dB-per-octave filter stage which can be set to two characteristics: AC (12 Hz), or DC (0 Hz).

Why does frequency bandwidth limiting make sense ?

In signal processing, sound is represented by AC voltages. Sound is audible - for young people - from about 20 to 20000 Hz. The elder the listener, the less he will hear high frequencies in particular.

In order to transmit these frequencies at optimum quality, the frequency response of an amplifier should be as wide and as "flat" as possible. At the low end of the scale, this limit is represented by DC, as there is no frequency lower than zero. In upward direction, the limit can be set to practically any frequency, but the higher, the more susceptible the device becomes concerning electro-magnetic interference. This is not audible in the first place, but may interfere with the useful signal and then become evident. Therefore, unrestricted frequency response attests thoughtlessness rather than remarkable engineering skill.

Here comes the volume pot and the power stage.

The pot is followed by the power amplifier, which is operated at +/-30V supply voltage and designed with very special operational amplifiers which are able to deliver much more power than ordinary op-amps would do. Additionally the amplifiers feature their own temperature monitoring, so they are able to protect themselves from overload. Overall gain is set to 8dB (factor 2.5).

For high-impedance headphones, the power amplifier delivers one of the highest voltage swings available. For low-impedance headphones on the other hand there is power in abundance, with a damping factor of 300. At the same time, distortion and dynamic range represent the limits of the technically feasible.

Why makes it sense to make such huge efforts ?

A headphone amplifier is a device designed to condition audio signals with regard to the very specific requirements of headphones. This doesn't sound too spectacular at the first glance and can be achieved relatively easily. As with many things however, the devil is in the details and much more effort is required to design **one** amplifier for **all** current headphone models.

Headphones per se are quite diverse, and there are two essential parameters: impedance and sensitivity.

In general, headphones with higher impedance can be regarded as less sensitive than headphones with low impedance (which is not generally true, but in the majority of cases). The sensitivity of headphones is usually stated in dB (sound pressure level) per milliwatt.

Extremes in this sense are the AKG K1000 with 74dB/mW on the one hand, and the Sennheiser HD25 with 108 dB/mW on the other hand: The K1000 requires 2500 times the power to achieve the same sound pressure as the HD25.

There is also the fact that headphones with high impedance usually require much higher voltage to achieve high loudness. Thus the amplifier *must* be designed with high internal supply voltages.

Why is a high damping factor essential ?

When actuated, electro-dynamic systems respond with a counterforce.

When the voice coil of a headphone has been displaced by the signal, an (error) current will be induced when it swings back to its initial position.

This current must be suppressed as far as possible, which is effected best if the amplifier's output impedance is the lowest possible. The damping factor describes nothing but the ratio between output impedance of an amplifier and a given load.

Since there is no known technical specifications, we define the load (voice coil impedance) as 50 ohms. This results in an output impedance of <0.17 ohms for the V90.

The power supply with its supersized toroidal transformer provides the power stage with +/-30 volts. The preamp stage is supplied with stabilized +/-18 volts.

Why are high supply voltages essential ?

A headphone doesn't really require high power, but from the equation $P = U^2 / R$ we can see that the square of the supply voltage determines the power into a given load resistance. The higher the headphone's impedance, the more voltage will be needed. But this deals with the achievable loudness to a limited extent only: Technically spoken, music lives on fast transients which put high demands on signal processing. And thus a fast transient can easily push an average amplifier with +/-15 volts supply to its limits. Due to our high supply voltage you will benefit from doubled output swing capability.

DISPOSAL



Disposal of Old Electrical & Electronic Equipment
(Applicable in the European Union and other
European countries with separate collection systems)

This symbol on the product or on its packaging
indicates that this product shall not be treated as
household waste. Instead it shall be handed over to
the applicable collection point for the recycling of

electrical and electronic equipment.

By ensuring this product is disposed of correctly, you will help prevent potential negative consequences for the environment and human health, which could otherwise be caused by inappropriate waste handling of this product.

The recycling of materials will help to conserve natural resources.

For more detailed information about recycling of this product, please contact your local Civic Office, your household waste disposal service or the shop where you purchased the product.

TECHNICAL DATA HPA V90

All Measurements RMS unwt'd., 20 Hz - 20 kHz, Pre-Gain set to 0 dB, Highpass active



Inputs:	2 x Cinch, unbalanced
Max. Input Voltage:	+ 21 dBu, Impedance 10 kOhms
Input Impedance:	10 kohms
Buffered Outputs:	2 x Cinch unbalanced
Nominal Input Sensitivity:	+6 dBu
Amplifier Overall Gain:	+8 dB
Overall Gain with PRE-GAIN :	-4 / +2 / +8 / +14 / +20 dB
Frequency Range:	0 Hz ... 55 kHz (- 0,5 dB) 0 Hz ... 200 kHz (-3 dB)
Damping Factor:	> 300 into a Load of 50 Ohms
Dynamic Range:	> 126 dB (A-wtd)
Noise:	< -102 dBu (A-wtd)
THD+N (1kHz/2x10V/100R = 1W)	< -108 dB / < 0,00035 %
THD+N (1kHz/2x4V/32R = 0,5W)	< -102 dB / < 0.0007 %
Crosstalk:	-110 dB (1 kHz) / -90 dB (15 kHz)
Headphone Outputs:	2 x ¼" (6.3 mm) TRS Jack

Max. Ausgangspegel:
(1kHz / < 0.1% THD+N)



R _L (x 2)	U _a (dBu)	U _a (V)	P _a (mW)
600	28,6	20,9	730
100	25,9	15,2	2300
50	21,7	9,4	1780
32	18,3	6,4	1300
16	11,8	3,0	550

Supply Voltage:	230 V AC / 115 VAC max. 10 VA
Case, Front, Back:	Aluminium
Dimensions:	170 x 49 x 126 mm (W x H x D)

JUMPER SETTINGS HPA V90

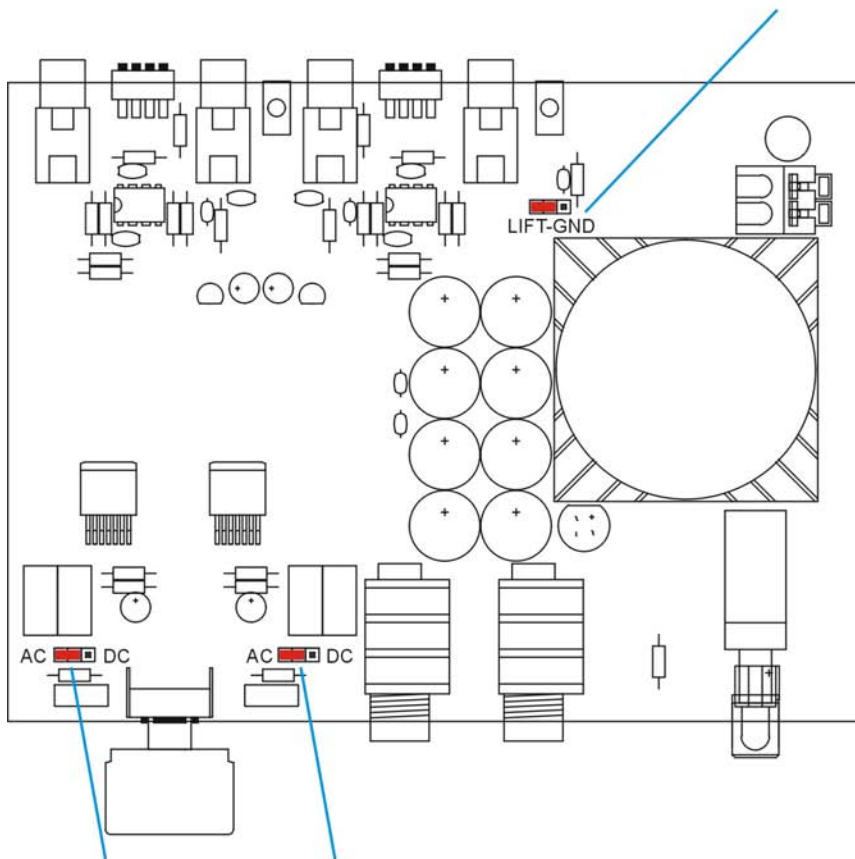
GROUNDLIFT JUMPER (see Page 7)	
 LIFT POSITION (ex works)	 GROUND POSITION



LO-CUT JUMPER (see Page 15)	
AC  DC AC-POSITION (12 Hz) (ex works)	AC  DC DC POSITION (0 Hz)

EU CONFORMITY STATEMENT:

We herewith declare that the following unit

Name: **VIOLECTRIC HPA V90**

Serial No. : -all -

is in conformity with the following EC directives:

2006/95 EG	Low voltage directive
2004/108 EG	Electromagnetic compatibility
EN 60065	Security directives for audio-,
JIS C 6065	video- und similar electronic devices

For verification of conformity with regard to electromagnetic compatibility the following harmonized standards are applied:

EN 50081-1 : 1992	Generic emission standard
EN 50082-1 : 1992	Generic immunity standard

Product family standard for audio, video, audio-visual entertainment apparatus:

EN 55013 : 2001	EN 61000-3-2 : 2000
EN 55020 : 2002	EN 61000-3-3 : 1995

This declaration is given under responsibility of:



LAKE PEOPLE *electronic GmbH*
Turmstrasse 7a
D-78467 Konstanz
Fon +49 (0) 7531 73678
Fax +49 (0) 7531 74998

A handwritten signature in blue ink that reads 'Fried Reim'.

Konstanz 10.03.2013 Fried Reim CEO

WARRENTY

Since 1986 we are constructing and manufacturing sophisticated electronics for ambitious customers.

Since the early beginnings we are trying hard by accompanying measures, the use of 1st choice components and multiple quality checks during production to avoid faults at large.

We are quiet effective in that and this is – amongst others - why we enjoy such a good reputation.

Despite all accurateness faults may occure which may derogate the proper operation of your product.

In this case your unit is protected by a **2-year Warranty !**

Needless to say that we will care for your product even after the expiration of the warranty. If it is necessary please dispatch your item to:

Lake People electronic GmbH
Turmstrasse 7a
D-78467 Konstanz

Fon +49 (0) 7531 73678
Fax +49 (0) 7531 74998
E-Mail info@lake-people.de

Your warranty claim begins with the date of purchase, which should be denoted on your proof of purchase.

Do not forget to include the receipt of sales or a copy of the receipt.

Please also include a short description of the fault(s).

For the reshipment we need you correct address !!

Care for a safe packaging. Best is to use the original packaging.

Please keep in mind that we cannot accept collect freight.

We will grant a quick repair and quick return of the unit.

In case of a warranty repair we will reship free of charge.

Please denote here the serial number and the date of purchase:

Serial Number

Date of Purchase