

# Service Manual

## Drum Washing Machine

**unique**  
**Klasse**

**KUD-WD1133S**



# DRUM WASHING MACHINE SERVICE GUIDE

■ What is Drum Washing machine.....	2
■ Product Spec.....	5
■ Diagram of operation Principles and Parts Classification.....	6
■ Classification per Assy.....	7
■ Parts list for each Assy.....	8
■ Control Part Function Spec.....	20
■ PCB Pin Arrangement .....	45
■ Electronic Parts List Spec.....	46
■ Power Defect.....	61
■ Noise Defect.....	62
■ Wirng Diagram .....	63
■ Installation .....	64

# ■ What is Drum Washing Machine?

---

## 1. Drum Washing Machine

Water consumption is reduced by using the power of the laundry falling (free-fall) created when rotating the drum resembling a sieve net. With temperature control system, this drum washing machine saves energy and improves washing performance at the same time.

## 2. Features of Drum Washing Machine

◆ Simultaneous supply of cold · hot water

As cold and hot water is supplied at the same time, heating time and energy is saved.

◆ Top-quality popup dial

The top-quality popup dial is used only during washing process.

◆ Dust filter

Filter to remove foreign substances, such as naps generated during washing, etc., is installed inside the drum.

◆ DD inverter motor

The direct-drive type, of which motor is directly connected to drum without an interim clutch, significantly reduces noise and vibration.

◆ Heating device is installed to enable boiling of the laundry.

◆ Large door creates grand appearance and makes it easy to put in and out the laundry.

◆ For pump drainage, the powerful pump speeds up drainage process.

### 3. Power System of “KLASSE” Drum Washing Machine

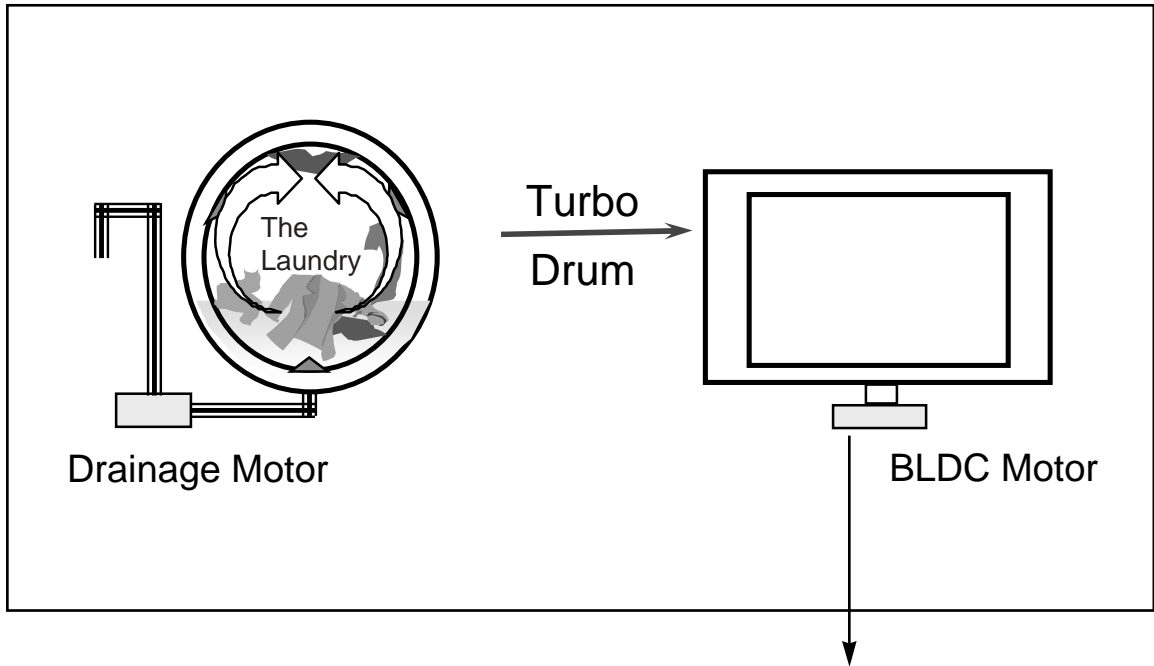

- DD Control: Direct drive type of direct connection between drum and motor
- Rotation by powerful high-performance BLDC motor
- Pump drainage type for built-in installation

---

## 4. Major Functions of Drum Washing Machine

### ① Washing

When rotating drum after putting in the laundry and detergent into the drum, the laundry are rotated by protrusions (lifters) attached inside the drum.

Washing is carried out with bending and impact actions generated by falling of the laundry to the top part of drum.

### ② Rinsing

Rinsing cleanly washes out detergent and dirt removed from the laundry after washing cycle.

### ③ Spin-drying

Weak, standard and strong cycles can be selected according to types of fabrics to be washed. Spin-drying is carried out by rotation (the centrifugal force) of drum according to the designated speed.

### ④ Drainage

Pump Drainage: Powerful pump for built-in installation and application of filter to remove foreign substances

## ■ Product Spec

### Product Spec.

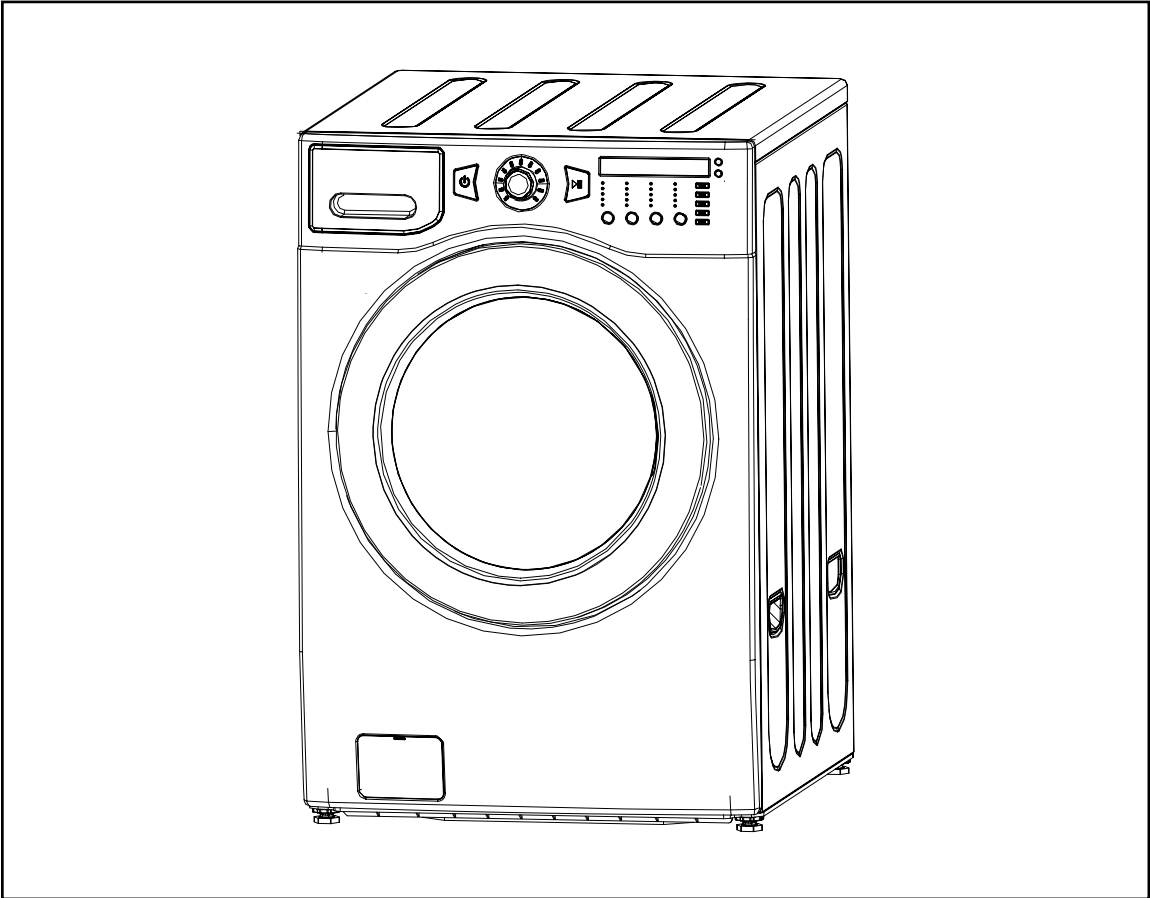

External Measurements (inches)		27"(width) x 31.8"(depth) x 40.1"(height)
Weight		198.4lbm
Rated Supply Power		120V 60Hz
Rated Consumption Power	Washing	200W (1100W during heating)
Washing Method		Drum type
Water Pressure		29kPa ~ 784kPa(0.3kgf/kg~8kgf/kg)

# ■ Diagram of Operation Principles and Parts Classification

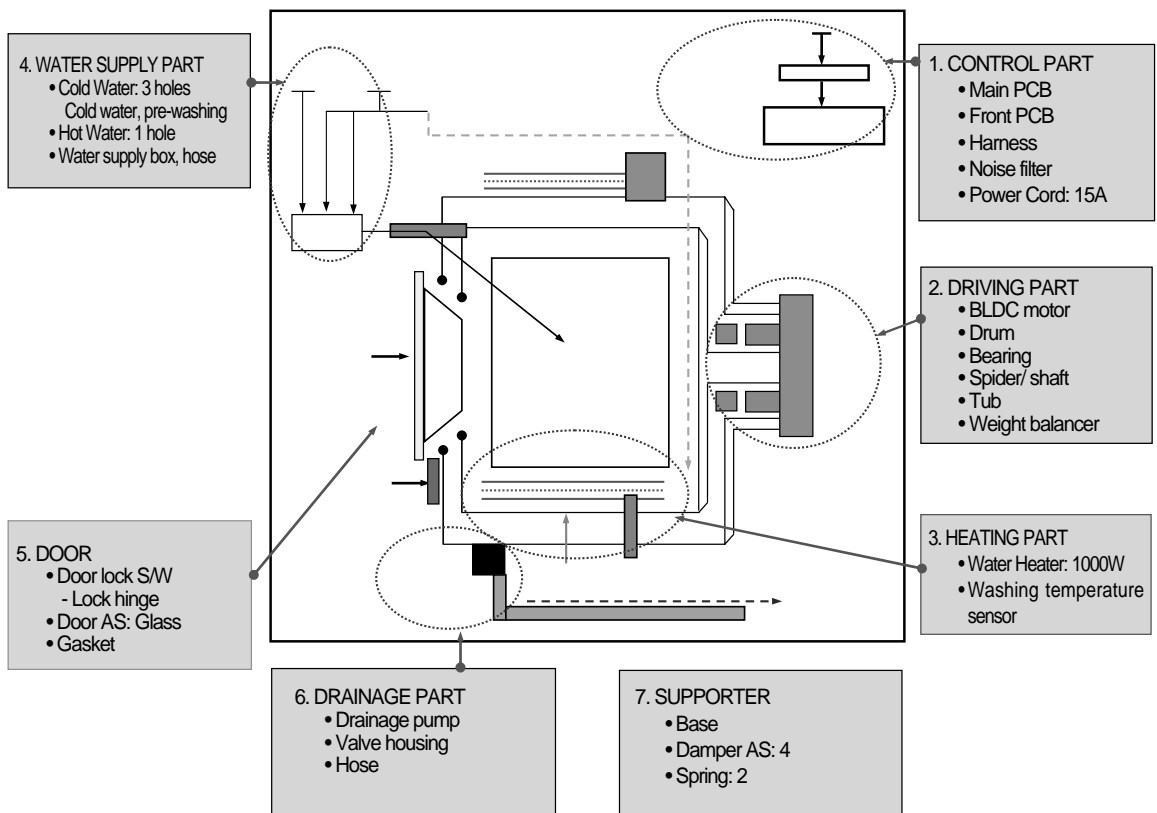

## ■ Classification per ASSY

---

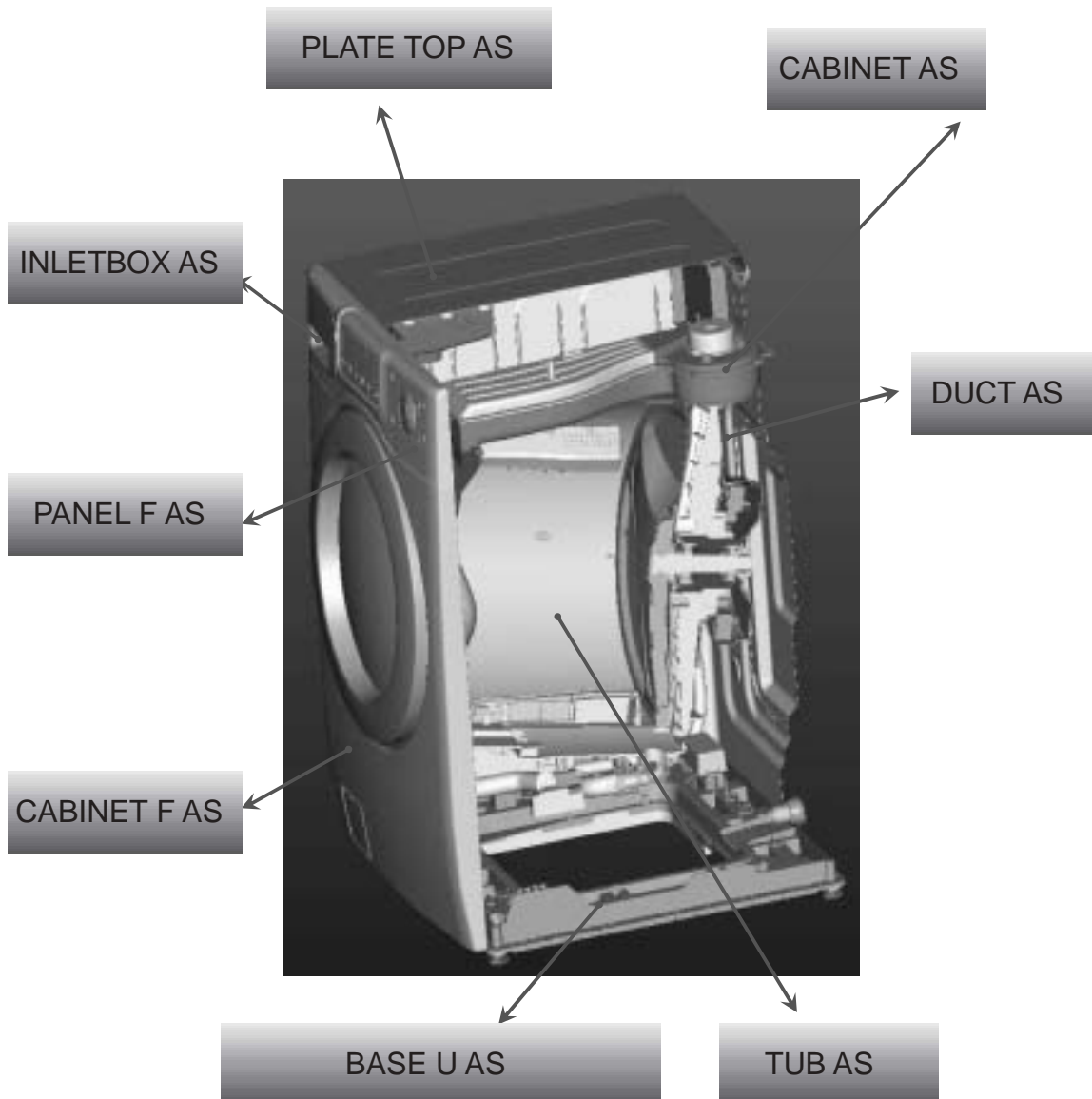



# ■ PARTS LIST FOR EACH ASSY

## 1. CABINET AS

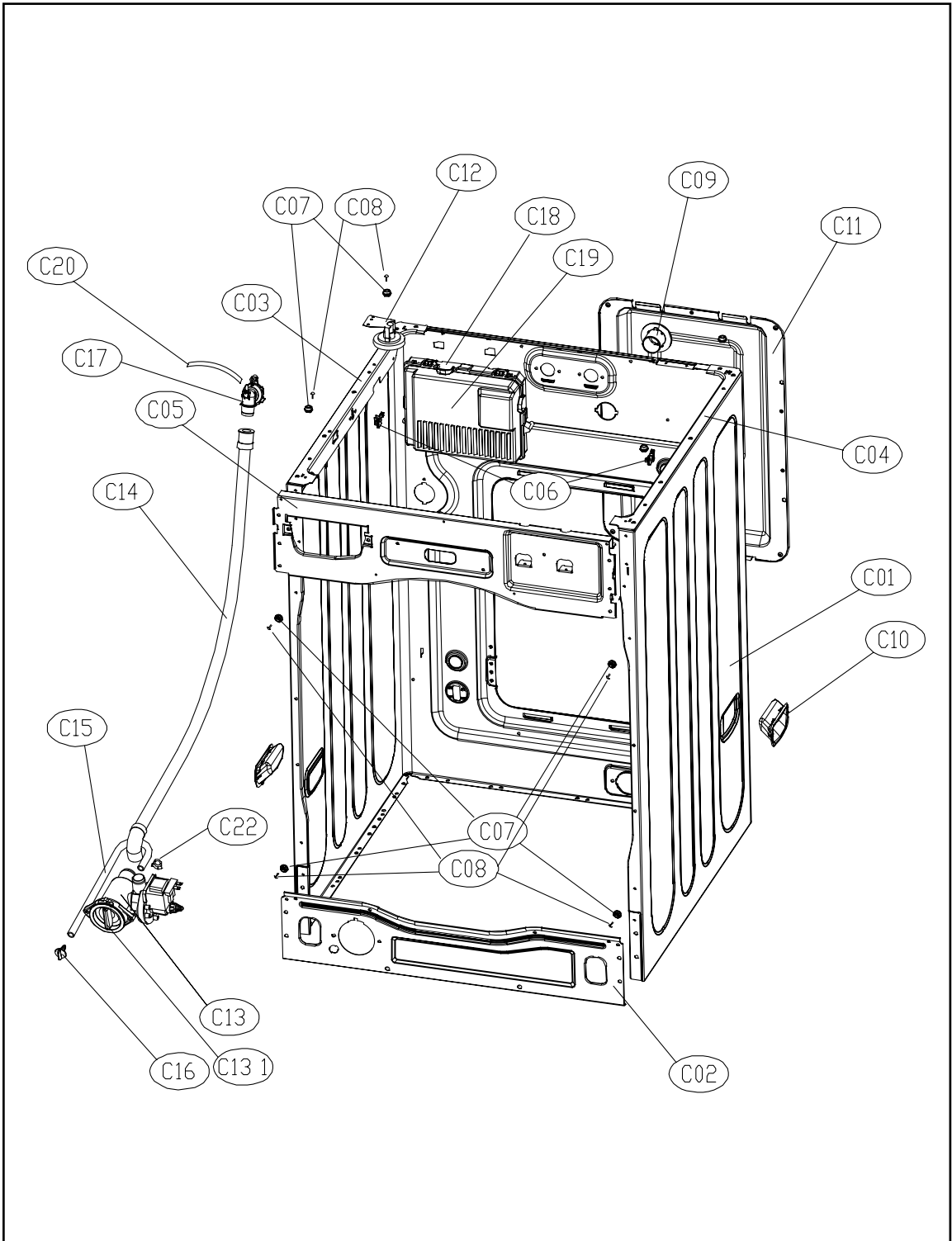

No	Part Name	Part Code	Description	Qty	Remarks
C01	CABINET	3610811740	SGCC 0.8t, Painting	1	1 Piece SVC part
C02	FRAME LOWER	3612206700	SBHG 1.2T	1	
C03	FRAME TOP L	3612206500	SGCC 1.6T	1	
C04	FRAME TOP R	3612206600	SGCC 1.6T	1	
C05	FRAME UPPER	3612208200	SBHG 1.2T	1	
C06	STOPPER SPRING	3615202200	POM	2	
C07	FIXTURE PLATE	3612008000	POM	8	
C08	SCREW TAPPING	7121401211	T2S PAN 4X12 MFZN	8	
C09	NOZZLE AIR	3618103110	PP	1	
C10	HANDLE CABINET	3612608100	PP	2	
C11	COVER BACK AS	3611425530	COVER B + PAD CABINET	1	
C12	SENSOR PRESSURE	3614825220	DWD-130RP	1	
C13	UNIT DRAIN PUMP AS	36189L5600	PUMP+FILTER	1	
C13-1	FILTER PUMP	3611910200	13KG HANYU FILTER	1	
C14	HOSE DRAIN I	3613271300	ST+EL 1,010mm	1	1 Piece SVC
-	ABSORBER HOSE DRAIN	3610115600	T10, 60x130	1	Part
-	CLAMP HOSE	3611203900	SK5 D=26	2	Fix Hose drain I
C15	HOSE WATER REMAIN	3613271410	EPDM, 13kg, UL 3t Round bending	1	
C16	CAP WATER REMAIN	3610916800	PP	1	
C17	CUFF DRAIN HOSE	3616802600	PP	1	
C18	PCB AS	PRPSSWAD24	USA WASHER, UL	1	WASHER
C19	COVER PCB M	3611427700	UL,ABS,VE-0856, MAIN PCB COVER	1	
C20	HOSE SIPHON	3613272210	EPDM, 13kg, UL 3t L=270	1	
C21	CLAMP HOSE	3611203900	Φ 26	1	
-	HARNESS AS	3612796T00	UL, 13kg Wash, Non bubble	1	

## 2. BASE U AS

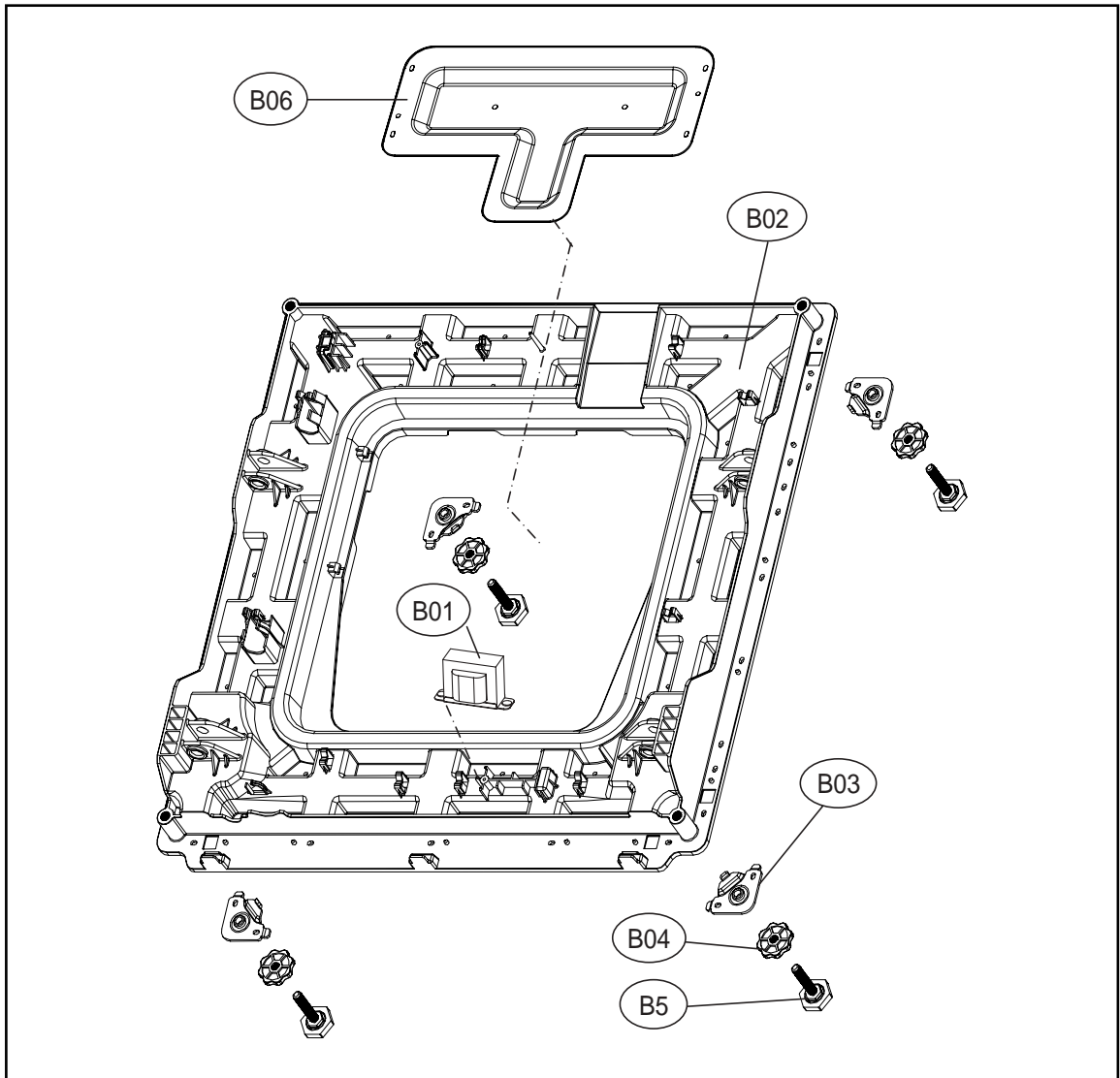

No	Part Name	Part Code	Description	Qty	Remarks
B01	REACTOR	52G043A110	RT-047K,L=150mm	1	
B02	BASE U	3610392700	PP	1	
B03	SUPPORTER LEG	3615303600	3.0T	4	
B04	FIXTURE LEG	3612006400	ABS, DWD-100DR	4	
B05	FOOT AS	3612100700	Foot+Special bolt, Double insert type Hybra-Nylon66	4	
B06	PROTECTOR HEATER	3618304600	SECC 0.35T	1	

### 3. TUB AS

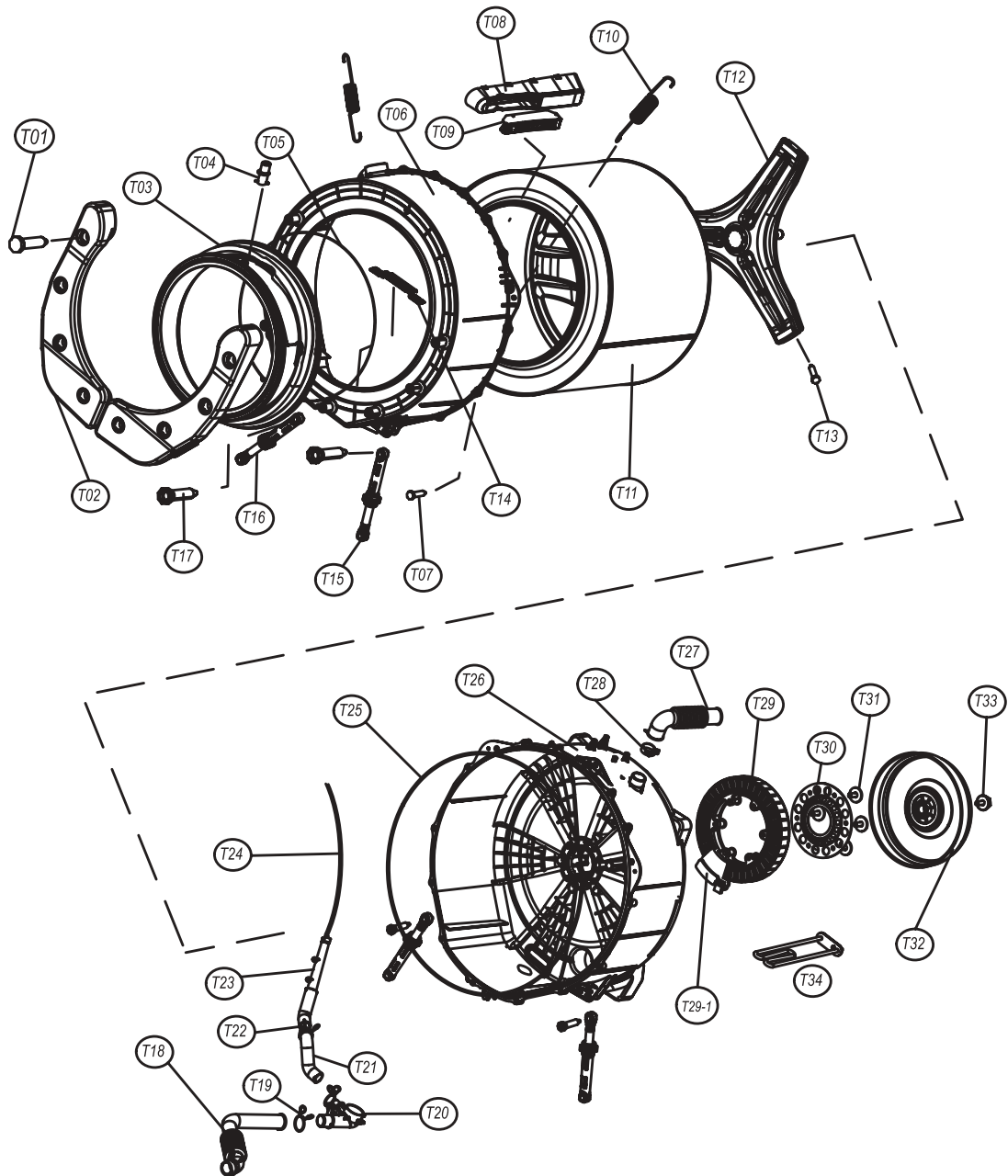

No.	Part Name	Part Code	Qt'y	Specifications	Color	Cost in USD(\$)	Remarks
T01	SPECIAL SCREW	3616029400	8	SWCH 8.5x30	NA		Fix Balance W.to Tub F
T02	BALANCER WEIGHT AS(L)	3616106900	1	13kg Drum	NA		
-	BALANCER WEIGHT AS(R)	3616106800	1	13kg Drum	NA		
T03	GASKET	3612322000	1	EPDM, 13kg, Wash only Nozzle shower	NA		
T04	NOZZLE SHOWER	3618104000	1	PP	NA		
T05	CLAMP GASKET AS	3611205300	1	Gasket, 13kg Drum	NA		
T06	TUB FRONT	3618828Y00	1	FRPP, 13kg Drum	NA		
T07	SPECIAL SCREW(TUB)	3616029800	15	SWCH 6.5x30	NA		Fix Tub F & R
T08	LIFTER BODY	361A400700	3	PP, 13kg Drum	Gray		
T09	CAP FILTER	3610917310	3	ABS, Non-Nano, 13kg	Gray		
-	FILTER	3611908410	3	ABS, Non-Nano, 13kg	Gray		STS mesh insert injection
T10	SPRING SUSPENSION	3615114800	2	13KG DRUM	NA		
T11	DRUM AS	3617008X00	1	SUS, 13kg	NA		
T12	SPIDER AS	361A300600	1	13kg, ALDC+S45C	NA		
T13	SPECIAL SCREW(SPIDER)	3616029500	6	STS 430, 8x25	NA		
T14	FIXTURE HEATER	3612006700	1	STS 430	NA		
T15	DAMPER FRICTION	361A700300	2	AWECO,HP3 60N/ 9mm Buffer4.0	NA		Tub F&R right
T16	DAMPER FRICTION	361A700110	2	70N AKS ST=170-260 DL=197.5	NA		Tub F&R left
T17	DAMPER PIN	361A700200	8	AKS D=14.5	NA		Tub & Base U
T18	HOSE DRAIN	3613269000	1	EPDM,PUMP	NA		
T19	CLAMP HOSE	3611203410	2	SK5, D=33	NA		
T20	DRAIN HOUSING I	36196TAM00	1	PP, Pump	NA		
T21	HOSE AIR TRAP	3613269700	1	EPDM, 13kg Drum	NA		
T22	CLAMP HOSE	3611204700	2	SK5, D=26	NA		
T23	AIR TRAP	361A500101	1	PP	NA		
T24	HOSE AIR	3613270600	1	ID=3.0, D=8, L=960mm	NA		
T25	GASKET TUB	3612321100	1	EPDR FORM, 13kg	NA		
T26	TUB REAR	3618828Z00	1	FRPP, 13kg Drum	NA		
T27	HOSE AIR	3613266300	1	EPDM,DWD-110RP	NA		
T28	CLAMP HOSE	3611203400	2	SK5, MFZN, D=35	NA		
T29	UNIT STATOR BLDC	36189L4840	1	30T,36Slot,2Snesor,	NA		
T29-1	BLDC HALL IC	3426D01002	1	PCB HOLDER AS	NA		
T30	BRACK HOUSING	3610609700	1	SESEN, 2.5T	NA		
T31	SPECIAL BOLT AS	3616063400	6	SWCH M8+Silock, 58mm	NA		Fix Stator to Tub R
T32	UNIT ROTOR BLDC	36189L4900	1	Magnet24,Serration,WR1238F001	NA		
T33	SPECIAL BOLOT AS	3616029600	1	SWCH,10x30,F/L Bolt,S.P/W	NA		Fix Rotor to Spider Shaft
T34	HEATER WASH	3612801740	1	UL.120V1.0KW6.7W/SQ.S TS.1R3A515003.L/W	NA		

## 4. INLET BOX AS

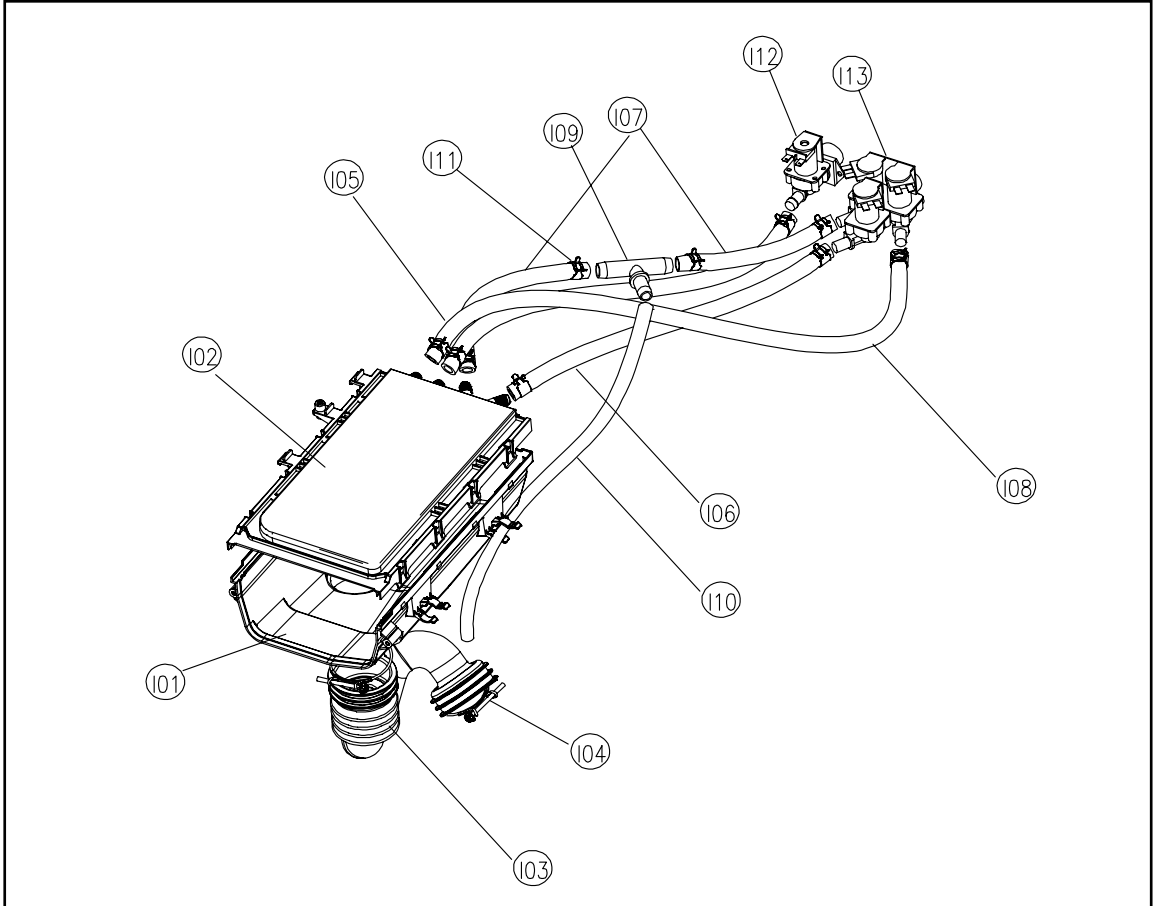

No	Part Name	Part Code	Description	Qty	Remarks
-	AS INLET BOX	3617510700	DWD-WD1131	1	
I01	INLET BOX	3617510800	PP	1	
I02	NOZZLE AS	3618104800	TOP+UNDER 용착	1	
I03	HOSE INLET	3613270300	EPDM	1	
I04	CLAMP AS	3611203200	∅ 60	2	
I05	HOSE WATER SUPPLY	3613270900	EPDM, ID9.9 OD14.5 L=410mm	1	
I06	HOSE WATER SUPPLY	3613270900	EPDM, ID9.9 OD14.5 L=380mm	1	
I07	HOSE WATER SUPPLY	3613270900	EPDM, ID9.9 OD14.5 L=230mm	2	
I08	HOSE WATER SUPPLY	3613270900	EPDM, ID9.9 OD14.5 L=530mm	1	
I09	PIPE JOINT(HOSE INLET)	3614413300	PP	1	
I10	HOSE SHOWER	3613270110	EPDM, ID=8.5 L=550	1	
I11	CLAMP SPRING	3611203800	ID=15.5 T=0.6 B=10	10	
I12	VALVE INLET	3615416701	120/60Hz UL BITRON 1WAY	1	
I13	VALVE INLET	3615416931	120/60Hz UL BITRON 3WAY	1	

## 5. CASE DETERGENT AS

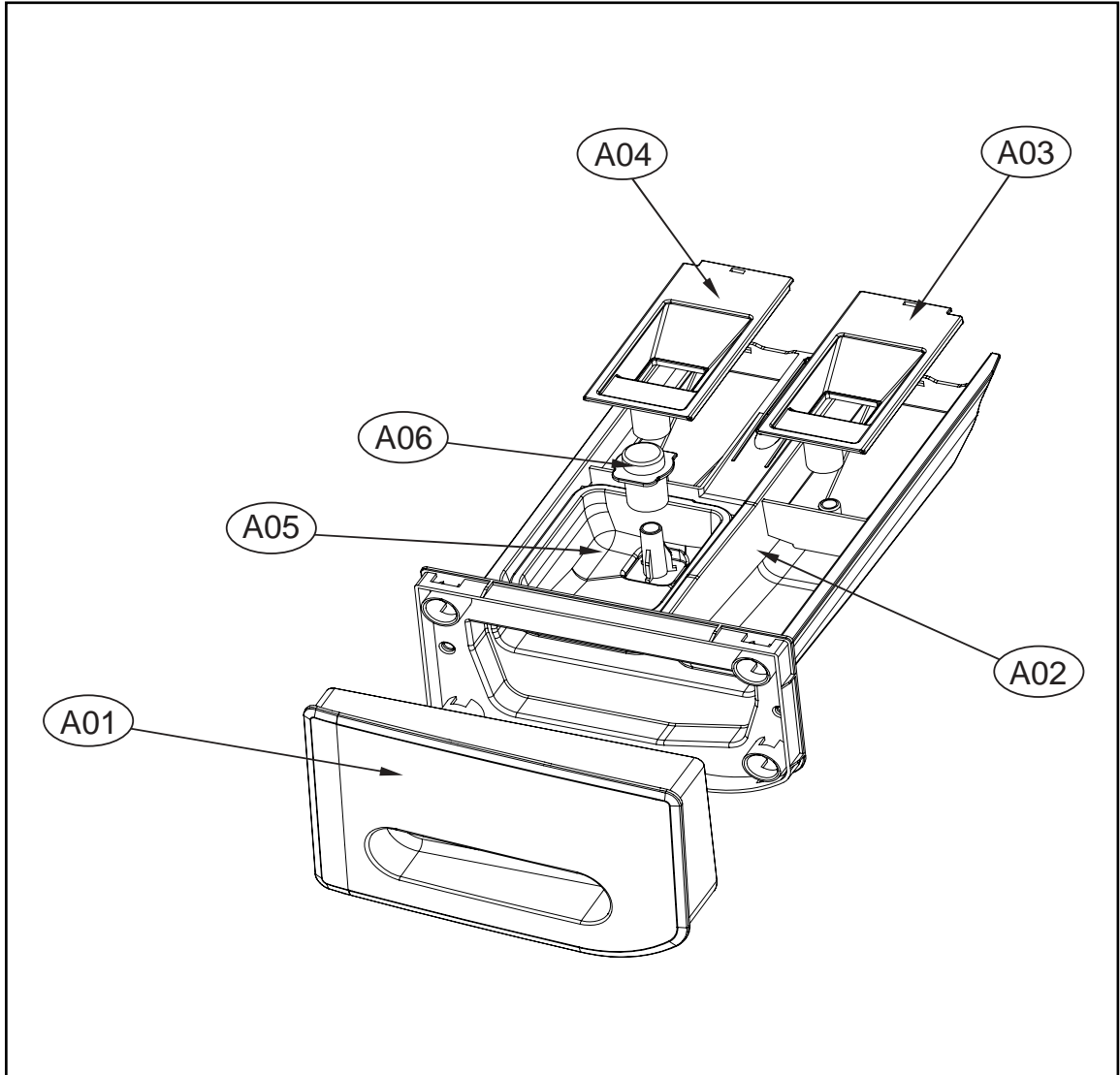

No	Part Name	Part Code	Description	Qty	Remarks
A01	CASE HANDLE	3611145500	ABS	1	
A02	CASE DETERGENT	3611145600	PP	1	
A03	CAP SOFTENER	3610917800	PP	1	
A04	CAP BLEACH	3610917900	PP	1	
A05	CASE LIQUID	3611145700	PP	1	
A06	CAP LIQUID	3610918000	PP	1	

# 6. CABINET F AS

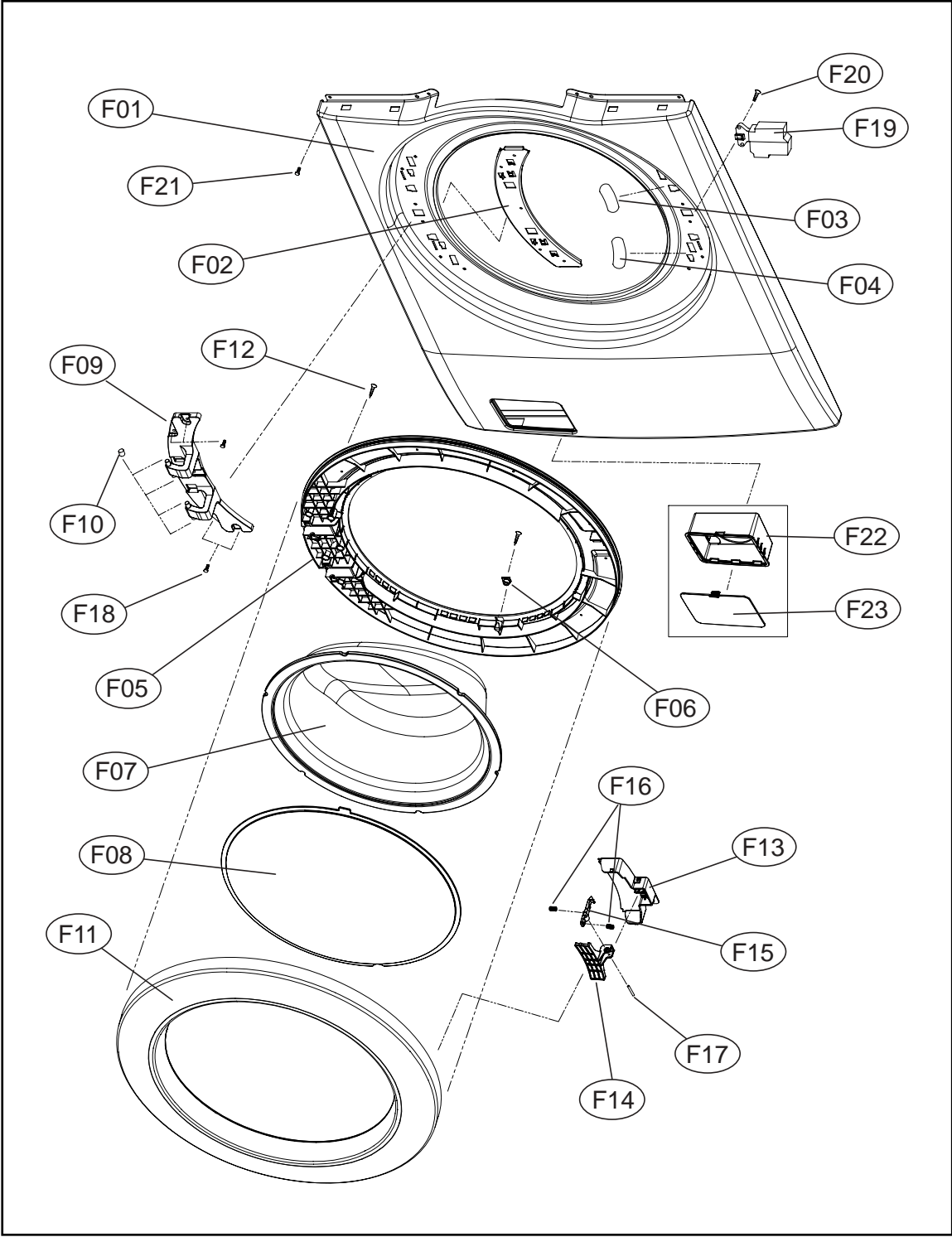



No	Part Name	Part Code	Description	Qtt'y	Remarks
F01	CABINET F	3610811820	SECD 1.0T PUMP	1	
F02	SUPPORT HINGE	3615304000	SGCC 1.6T	1	
F03	LABEL SAFETY R	3613555800	PVC,130RP'S Cab. F Safety Label	1	
F04	LABEL WARNING	3613558500	PVC,130RP'S Cab. F Warning Label	1	
-	LABEL RATING	3613558200	PVC, UL ASKO Rating label	1	
F05	FRAME DOOR INNER	3612206800	TB53	1	
F06	STOPPER DOOR	3615202300	PP	1	
F07	DOOR GLASS	361A110600	GLASS	1	
F08	PROTECTOR GLASS	3618304300	ABS(Transparent)	1	
F09	HINGE DOOR	3612902900	ALDC	1	
F10	CAP HINGE DOOR	3610916500	POM	4	
F11	FRAME DOOR OUTER	3612206900	ABS	1	
F12	SCREW TAPPING	7115402008	T1S FLT 4x20 SUS430	16	
F13	COVER HANDLE	3611426700	ABS	1	
F14	HANDLE DOOR	3612609000	ABS	1	
F15	HOOK DOOR	3613100800	ZNDC	1	
F16	SPRING HOOK	3615113700	SUS ID=4.3, NI=7, D=Ø0.9	2	
F17	PIN HANDLE	3618200100	SUS D=3.0	1	
F18	SCREW TAPPING	3616030000	F/L BOLT(SE) 5*12 SUS	4	
F19	SWITCH DOOR LOCK	3619046410	DF F11 110 125V 16A PTC-SOLENOID	1	
F20	SCREW TAPPING	7122401608	T2S TRS 4X16 SUS 430	2	
F21	SCREW TAPPING	3616029950	TTS"S" HEX F/L 4*8	4	
F22	CASE PUMP	3611141400	PP	1	
F23	COVER PUMP	3611426800	ABS	1	

## 7. PANEL F AS

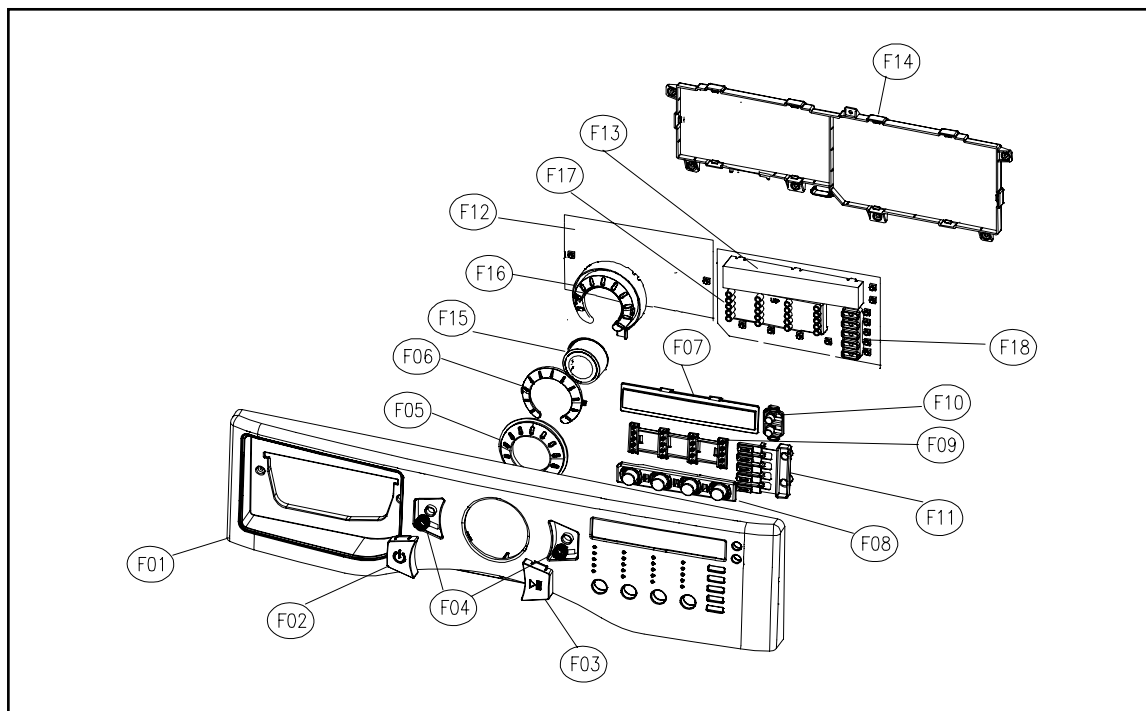



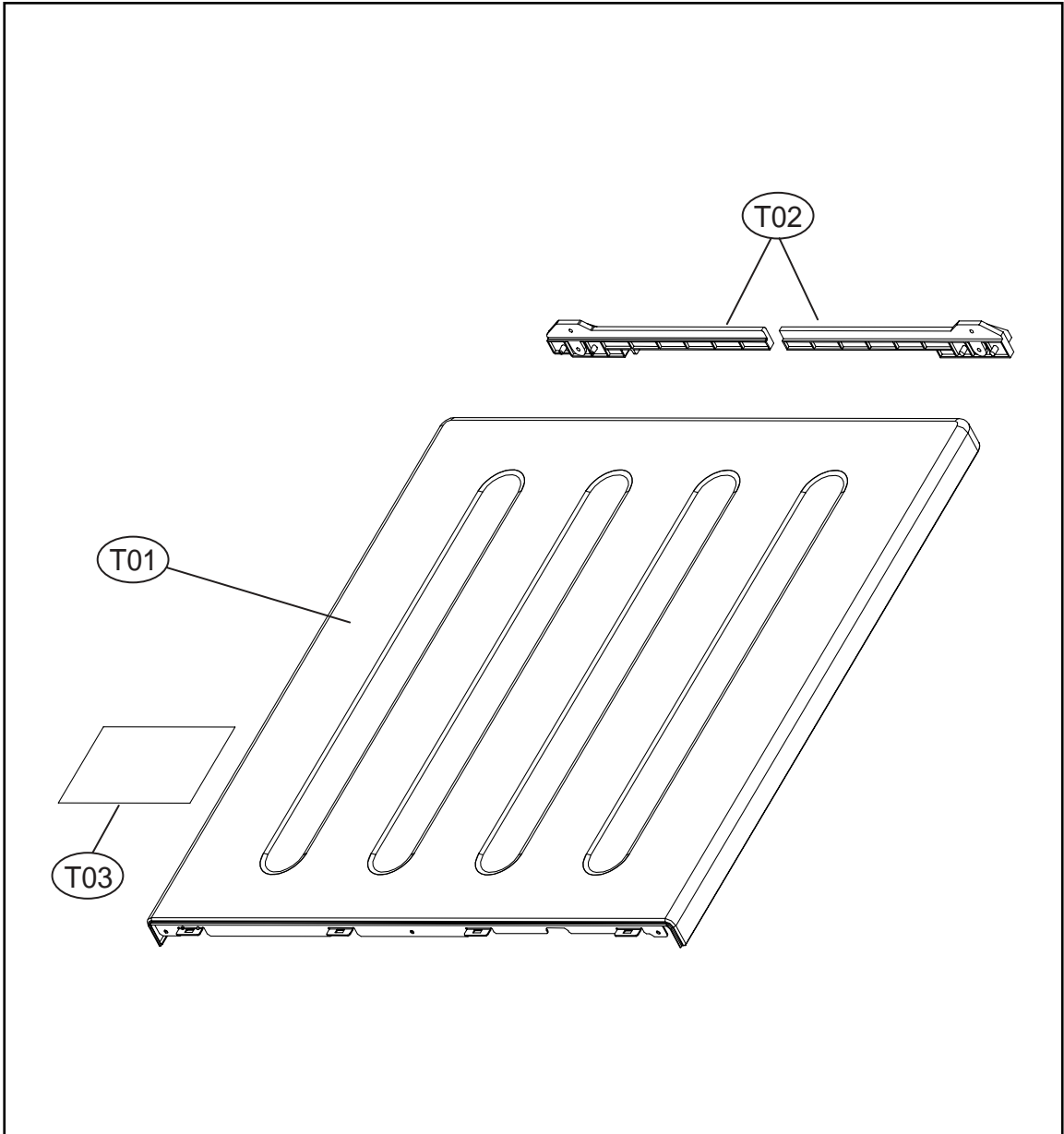

No	Part Name	Part Code	Description	Qty	Remarks
-	PANEL-F AS	3614287300	DWD-WD1131	1	
F01	PANEL-F	3614287200	ABS + SILK PRINT	1	
F02	BUTTON POWER	3616635900	ABS	1	
F03	BUTTON START	3616636000	ABS	1	
F04	SPRING BUTTON	3615115700	SUS304	2	
F05	DECO COURSE	3611685400	ABS	1	
F06	WINDOW COURSE	3615504800	ABS(Transparent) (TR558)	1	
F07	WINDOW DISPLAY	3615504900	ABS(Transparent) (UT-0510)	1	
F08	BUTTON FUNCTION	3616636100	ABS	1	
F09	WINDOW FUNCTION	3615505000	ABS	1	
F10	BUTTON OPTION	3616636200	TR 558 ABS(Transparent)	1	
-	SCREW TAPPING	7122401411	T2 TRS 4x14 MFZN	7	
F11	BUTTON TIME	3616636300	ABS	1	
F12	PCB -F AS	PRPAFR9X00	DWD-WD1131	1	
F13	CUSTOM LED	3613052900	ABS	1	
F14	CASE PCB-F	3611145300	ABS(5VB, VE-0856),UL	1	
F15	BUTTON DIAL AS	3616634700	DWD-130RP	1	
F16	HOLDER COURSE	3613053000	ABS(5VB, VE-0856),UL	1	
F17	HOLDER LED	3613053100	ABS(5VB, VE-0856),UL	1	
F18	HOLDER OPTION	3613053200	ABS(5VB, VE-0856),UL	1	

## 8. PLATE T AS

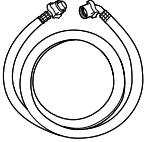

No	Part Name	Part Code	Description	Qty	Remarks
T01	PLATE TOP	3614533010	SECD 1.2T	1	
T02	PLATE SUPPORTER AS	3615304110	ABS + EPDM	2	
-	SCREW TAPPING	7122401411	T2S TRS 4x14 MFZN	4	
T03	LABEL CAUTION	3613553831	PVC	1	
-	ENERGY GUIDE	3613558310	Energy Label, 13kg Drum	1	

## 9. ACCESSORY

A01	A02	A03	A04	A05
				

No.	Part Name	Part Code	Descriptions	Qt'y	Remarks
A01	HOSE DRAIN O AS	3613268500	DWD-800W, L=1,500	1	
	GUIDE DRAIN HOSE	3612502300	PP	1	
A02	HOSE INLET AS	3613271500	REFLEX, PVC 1.3M	1	Cold
	HOSE INLET AS	3613271510	REFLEX, PVC 1.3M	1	Hot
A03	UNIT SVC WRENCH	36189L3X00	PO+Coating, 2.3T DWD-110RP	1	
A04	MANUAL OWNERS	4589A61600	ASKO Manual	1	English & French
A05	CAP HOLDER	3610916400	PP, DWD-10RP	4	

# Control Part Function Spec

## 1. SEQUENCE CHART

Classification		Processing Time	Normal		Cotton		Sanitary		Bulky	White
			Small	Low	Small	Low	Small	Low		
Pre Wash	Sensing	10sec								
	Water Supply	2min								
	Prewash	10min								
		8min								
	Drain	1min								
	Balancing Spin	2min								
Meduim Spin	3min									
Wash	Sensing	20sec								
	Water Supply	2min								
	Washing1 (Heating)	50min					53min	57min		
		45min							37min	
		30min	28min	32min						20min
		25min			16min	17min				
15min										
Rinse	Drain	1min								
	Balancing Spin	2min								
	Meduim Spin	3min								
	Water Supply	2min								
	Rinsing 1	3min								
	Drain	1min								
	Balancing Spin	2min								
	Meduim Spin	3min								
	Water Supply	2min								
	Rinsing 2	3min								
	Drain	1min								
	Balancing Spin	2min								
	Meduim Spin	3min								
	Water Supply	2min								
Rinsing 3	3min									
Spin	Drain	1min								
	Balancing Spin	2min								
	Main Spin	9min								
		7min								
6min										
End	Cloths Release	60sec								
	END	10sec								
Remain Time Display			1:05	1:09	53	54	1:30	1:34	1:14	1:02
NOTE		1. Normal : W/C + Wash + Soil Normal + Rinse 2 + Medium Spin 2. Cotton : W/C + Wash + Soil Normal + Rinse 2 + Ex.High Spin 3. Sanitary : E/C + Wash + Soil Normal + Rinse 2 + Medium Spin 4. Bulky : C/C + Wash + Soil Normal + Rinse 2 + Mediuem Spin 5. White : W/C + Wash + Soil Normal + Rinse 2 + Mediuem Spin								

Classification		Processing Time	Heavy Duty	Delicate	Wool	Perm Press	Speed Wash	Drum-C
Pre Wash	Sensing	10sec						
	Water Supply	2min						
	Pre Wash	10min						
		8min						
	Drain	1min						
	Balancing Spin	2min						
	Meduim Spin	3min						
Wash	Sensing	20sec						
	Water Supply	2min						
	Washing1 (Heating)	50min						
		45min	37min					
		30min						Soak 30min
25min					27min			
15min		13min	6min		8min	13min		
Rinse	Drain	1min						
	Balancing Spin	2min						
	Meduim Spin	3min						
	Water Supply	2min						
	Rinse 1	3min						
	Drain	1min						
	Balancing Spin	2min						
	Meduim Spin	3min						
	Water Supply	2min						
	Rinse 2	3min						
	Drain	1min						
	Balancing Spin	2min						
	Meduim Spin	3min						
	Water Supply	2min						
Rinse 3	3min							
Spin	Drain	1min						
	Balancing Spin	2min						
	Main Spin	9min						
		7min						
	5min							
End	Cloths Release	60sec						
	END	10sec						
Remain Time Display			1:44	37	30	1:04	33	1:20
NOTE		1. Heavy Duty : W/W + Pre Wash + Wash + Soil Normal + Rinse 3 + High Spin 2. Delicate : C/C + Wash + Soil Normal + Rinse 1 + Low Spin 3. Wool : C/C + Wash + Soil Light + Rinse 1 + Low Spin 4. Perm Press : W/C + Wash + Soil Normal + Rinse 2 + Low Spin 5. Speed Wash : C/C + Wash + Soil Light + Rinse 1 + Medium Spin 6. Drum-Cleaning : C/C + <b>Soak</b> + Soil Light + Rinse 2 + Low Spin						

## 2. Composition per Function

### 2-1. Water Supply

#### 1) Water Temperature Selection

Water supply algorithm differs according to water temperature selected among 5 levels.

In other temperatures, with the exception of cold water, constant temperature control is executed.

Cold water and hot water operation is carried out in turn according to the target temperature.

Water Temp.	Target Temp.	Target 1	Target 2
Extra Hot/Cold	67°C	67°C	70°C
Hot/Cold	41°C	40°C	42°C
Warm/Warm	31°C	30°C	32°C
Warm/Cold	31°C	30°C	32°C
Cold/Cold	-	-	-

2) For Cold/Cold, valve operation does not change according to temperature and only the time unit of cold on for 7sec and off for 9sec is set to supply cold water per each unit of 16sec.

#### ① Pre-wash V/V Operation

On for 3sec/ off for 2sec - Twice: Removing residual detergent from water supply box

② During the initial water supply for washing water is received 5mm higher than the set level.

#### 3) How to Insert Bleach

##### ① During Washing

Operation for 12sec after 3-minute washing in wool, delicate and speed wash courses

Operation for 12sec after 5-minute washing in cotton course

Operation for 12sec after skipping soaking and 4-minute of washing in Drum-cleaning course

Operation for 12sec after soaking and 4- minute of washing in Drum-cleaning course

---

## 2-2. Drenado

### 1) Operación de la bomba - ciclo de lavado

- ① La bomba trabaja continuamente antes de concluir el drenado
- ② En el ciclo de exprimido, cuando ya ha sacado el agua, enciende por 18sec y apaga por 3sec

## 2-3. Detección del Sensor

### 1) Sensor de nivel de agua

- Datos de nivel de agua

<b>Classification</b> <b>Water Level</b>	<b>Height</b> <b>(mm)</b>	<b>Frequency</b> <b>(KHz)</b>	<b>Remarks</b>
Spec. Small	130	24.62	
Spec. Low	130	24.62	
Washing Small	130	24.12	
Washing Low	130	23.84	
Standard Rinsing	160	24.17	
Rinsing	160	23.3	
Additional Rinsing	175	23.92	
Tub Washing	195	23.77	
Overflow	260	22.6	
Safety	125	24.7	
Reset	125	24.68	



---

2) Sensor Temperatura de lavado

① Resistencia estándar of  $4.7k\Omega$ - $49^{\circ}C$ ...

② Datos Sensor de Temperatura

Temp. °C	Resistance( $\Omega$ )	Voltage	Remarks
0	35.97	0.58	
10	22.76	0.86	
20	14.77	1.21	
22	13.57	1.29	
24	12.48	1.37	
25	11.98	1.41	
27	11.04	1.49	
29	10.18	1.58	
30	9.78	1.62	
32	9.04	1.71	
34	8.36	1.80	
36	7.74	1.89	
38	7.17	1.98	
40	6.65	2.07	
49	4.7	2.50	
55	3.85	2.75	
60	3.24	2.96	
65	2.74	3.16	
75	1.99	3.51	

---

## 2-4. Control de Voltage (operación anormal)

### 1) Control de Voltage

#### ① Voltage Normal

El acoplamiento de V. C.C. después de la rectificación de onda es registrado por el IPM de 310 ~ 330V. Cuando el motor comienza la operación, el voltaje de C.C. cambia con la energía consumida y la fuerza contra electromotriz.

#### ② Identificación de Voltage anormal

A. Al llegar la fuerza contra electromotriz

☞ En caso de 450V o mayor

B. Falla subita de energía / consumo excesivo de energía

☞ En caso de 185V o menor

## 2-5. Control de Corriente (operación anormal)

### 1) Detección de Corriente Anormal

① Corriente Anormal de CC a través del IPM, medida durante la rotación del motor a alta velocidad  
10A~12A o mayor

② Detección de Corriente Anormal.- Guarda el valor más alto registrado y promedia entre los valores actuales inmediatos y actualiza dichos datos.

---

## 2-6. S/W de Puerta

### 1) Operacion del S/W de Puerta

#### ① Seguro de puerta

3s. después de la operación del bimetálico del S/W de puerta, debe pulsar 20msec el solenoide hasta bloquear la puerta. El bimetálico inicia la operación al presionar el botón de encendido.

#### ② Desbloqueo de Puerta

La placa bimetálica del S/W se apaga y el pulso de 20msec en el solenoide se registra hasta que abra la puerta.

③ El motor o cualquier parte comienza la operación solamente cuando la puerta es bloqueada.

④ La puerta es cerrada si la temperatura medida por el sensor es mayor de 55 °C o mayor, o el nivel de agua está por arriba del nivel de seguridad.

⑤ La puerta se puede abrir inmediatamente cuando el ciclo finaliza.

⑥ Durante una pausa, la puerta se puede abrir si la temperatura y el nivel de agua lo permiten.

### 2) Desbloqueo de puerta

① Para agregar alguna prenda durante el lavado, la puerta puede ser abierta, presionando PAUSA y posteriormente el botón DESBLOQUEO.

② El sistema de desbloqueo de puerta inicia la secuencia para obtener las condiciones de seguridad de nivel o temperatura que permitan abrir la puerta

---

## 2-7. Sensor de carga

1) El Sensor de carga determina el nivel de agua

- ① Realiza la detección de carga al seleccionar; Normal. Cotton, Sanitary.
- ② La detección se realiza con la carga seca, antes de iniciar el ciclo de lavado.
- ③ Cuando el motor opera a 75 r.p.m por 10sec, la carga es medida con los datos registrados.

2) Sensor de carga para exprimido/secado

- ① La detección se realiza con la carga mojada, en el primer exprimido, al final del ciclo de lavado
- ② Al operar el motor a 75 r.p.m por 10sec, determina la carga con los datos de salida del motor.
- ③ Los valores bajos para el desbalanceo y exprimido principal se seleccionan según la carga en base a los datos de salida del motor

## 2-8. Child Lock

- ① Child lock mode begins by pressing 'Beeper' button during cycle.
- ② In child lock mode, all buttons, with the exception of power button, are not operated.
- ③ In child lock mode, cycle display window is lit to show that child lock has been applied. Also, the remaining time is displayed in '18:88' window.
- ④ Lock mode is cleared by pressing 'Beeper' button as was done when starting child lock mode.

---

## 3. Functions per Cycle

### 3-1. Washing Cycle

#### 1) Classification of Washing

- ① Pre-washing and soaking are carried out before main washing cycle.
- ② Decided value refers to water level and time decided by load sensing in standard, boiling and thrifty boiling courses. In other sources, it means the pre-set time according to the designated water level.
- ③ Soaking is the cycle consisted with water supply and washing only. Main washing begins immediately after this cycle without drainage.
- ④ In pre-washing and soaking cycles, only cold water is used and heating is not administered.

#### 2) Heater Operation

- ① Washing heater does not re-operate once turned off after reaching the set temperature.
- ② Even when target water temperature is not reached, washing cycle is finished when washing time expires.

#### 3) Re-supply of water

- ① Re-supply is carried out in case water level detected per 2 minute after water supply completion is lower than the set water level.
- ② Motor is stopped during re-supply.
- ③ During washing, re-supply is carried out up to 10 times. After the 10th time, re-supply is not administered even if water level drops.
- ④ Re-supply is not carried out if more than half of washing time has passed and heater is turned off.

---

## 3-2. Rinsing Cycle

### 1) Water Supply Cycle

- ① When selecting 'add water for rinsing', water is supplied to the water level of additional rinsing.
- ② Only cold water is supplied in rinsing cycle.
- ③ In the last rinsing, fabric softener is inserted by opening both cold water V/V and pre-washing V/V at the same time.

### 2) Re-supply of Water

- ① Water level is checked 1 minute after starting of rinsing cycle. Then, water is re-supplied up to the designated water level.

### 3) Drainage

- ① To administer drainage after completing washing at water temperature of 55°C or higher, drainage is carried out after dropping water temperature by supplying cold water to high level.
- ② When drainage cycle begins, drainage motor is continuously kept on.

### 4) Interim Spin-drying

- ① Interim spin-drying is administered up to the r.p.m designated per each course.  
The following cycle begins if R spin-drying is not reached after 20 times of balance spin-drying.
- ② After completion of washing cycle, load sensing is carried out before the first interim spin-drying to detect load. Then, the cycle proceeds to main spin-drying by differing standard unbalance values according to the load.

---

### 3-3. Spin-drying Cycle

#### 1) Drainage

- ① Drainage set time is 1min.
- ② When drainage is completed, 1 minute is reduced from the overall cycle.

#### 2) Balance Spin

Motor running during balance spin

- ① Spreading the laundry : Rotating the same 45rpm with left and right direction alternately.
- ② Attaching stop : Attaching the laundry to drum inside with constant speed.
- ③ Unbalance checking point : First step, check the U.B at 95 rpm, 160rpm  
Second step, check the U.B at 95 rpm, 350rpm  
Third step, at 300rpm. if the unbalance data is over the criterion  
This process will be repeated
- ④ Drain step : Drain at water around 160rpm
- ⑤ After drain, check the unbalance data again. This is so-called balance spin step.

#### 3) R (Real) Spin-drying

- ① 'R spin-drying' refers to the process until completion of spin-drying after B spin-drying.
- ② The r.p.m reached differs according to the spin-drying cycle selected.
- ③ When acceleration ends during spin-drying, constant-speed operation is carried out at the r.p.m set in the selected cycle. Breaking is carried out after deceleration to app. 450 r.p.m.
- ④ When stopping cycle by pressing temporary stop button during spin-drying, breaking is carried out to stop motor.
- ⑤ Max. r.p.m operation time according to spin-drying selection

Spin-Drying Classification	Max. r.p.m	Time of Max. r.p.m Maintenance	Remarks
Low	550 r.p.m	330sec	
Medium	790 r.p.m	270sec	
High	990 r.p.m	40sec	
Extra High	1050 r.p.m	10sec	

#### 4) No Drainage

- ① Cycle is completed without drainage after rinsing is finished

---

### 3-4. Ending

#### 1) Untwisting

- ① This cycle aims to prevent creasing by loosening the laundry attached to the inner wall of drum after completion of spin-drying. Untwisting is carried out for 30sec.
- ② Motor is operated according to the water stream of untwisting.

#### 2) Ending

- ① After completion of untwisting, buzzer is sounded for 10sec and power is turned off.
- ② In case additional drying cycle has been set, drying cycle is carried out after untwisting.
- ③ After ending process begins, door lock is cleared.



---

## 4. Button Functions

### 4-1. Power

- 1) This electronic power switch turns on/ off display.
- 2) Automatic Power Switch Off
  - ① Power is turned off immediately after completion of entire cycles or the selected cycle.
  - ② Power is automatically turned off in 10 minutes if no button control is made after power on.
- 3) Initial Display for Power Only
  - ① All course LED is turned on
  - ② 18:88 LED displays '---'.

### 4-2. Start/Pause

- 1) Normal course begins when pressing button after turning on power S/W.
- 2) Operation begins by pressing button after setting a program course or automatic course of 11 varieties.
- 3) If button is pressed during operation, blinking of cycle lamp changes to lighting only and operation stops. When button is pressed again, operation restarts from the point of temporary suspension.
- 4) If cycle is changed by controlling button or encoder switch in temporary suspension state, the mode is changed to the initial mode.
- 5) Lock is cleared if in the corresponding conditions by judging values of washing temperature sensor or water level during temporary suspension.

---

### 4-3. Wash/Rinse

- 1) Range of temp. selection differs according to the course selected. (Refer to washing functions per cycle.)
- 2) The front part of text displayed indicates water temperature for washing and the back part indicates water temperature for rinsing.  
ex) Warm / Cold  
    Warm : Water temperature for washing  
    Cold : Water temperature for rinsing
- 3) Cold water and hot water supply method differs according to water temperature selection. Heating temperature also differs.
- 4) For sanitary course, water temperature is fixed at 'Extra Hot/Cold'. When pressing water temperature button during temporary suspension, buzzer is sounded and water temperature selection is not made.
- 5) Even in sanitary course, water temperature selection can be made during rinse spin from 'Warm/Warm' to 'Cold/Cold'.

### 4-4. Spin Speed

- 1) When pressing button, LED is repetitively lit in the order of " Medium → High → Extra High → No Spin → Low'.
- 2) If drying cycle is selected, operation is carried out as extra high regardless of spin selection.
- 3) 18:88 display shows the remaining time.
- 4) During cycle, selection change is possible after temporary suspension.

---

#### 4-5. Soil Level

- 1) When pressing button, LED is repetitively lit in the order of " Normal → ▼ → High → Off → Light → ▼'
- 2) Soil level can be selected only when washing cycle is set.
- 3) Soil level is operated in courses other than 'Drum Cleaning', 'Wool' and 'Speed Wash'.
- 4) Washing time changes according to the selected soil level.  
ex) In case of normal course, water temp. of Warm/Warm and water level of 'low' In the order of Soil Level 'Light - ▼ - Normal - ▼ - High', washing time changes in the order of '18min - 23min - 28min - 31min - 33min'.
- 5) Selection can be changed during cycle after temporary suspension.
- 6) Overall cycle time is shown in 18:88 display.

#### 4-6. Beeper

- 1) Beeper button operates in 5 steps.  
Changing in the order of 'HIGH--> ▼ --> Low --> ▼ --> Beeper Off'.
- 2) After change, it is saved in EEPROM.

#### 4-7. Delay Wash

- 1) Preset time indicates ending time of the entire cycle.
- 2) When pressing preset button, time changes in the order of 2→ 3→ 4→ … → 12→ 2.
- 3) After selecting preset time, cycle change is possible before entering preset mode by pressing start/ temporary stop button.  
However, cycle cannot be changed after entering preset mode.

- 
- 4) To preset operation, select cycle → select preset time → press start/ temporary stop button.
  - 5) The selected cycle is displayed for 3 seconds when pressing start/ temporary stop button after entering preset mode to check the selected cycle.
  - 6) Preset is not possible in wool, delicate and drum cleaning courses.

#### **4-8. Pre-Wash**

- 1) Button is operated only when washing is selected.
- 2) Pre-wash is not available in wool, speed wash and drum cleaning courses.
- 3) When pressing button, pre-wash is added and LED is lit. LED is turned off when pressing the button again.
- 4) Pre-wash LED is turned off when pre-wash is completed.

#### **4-9. Rinse+Spin**

- 1) Rinse + spin is not available in drum cleaning course.
- 2) When pressing button, rinsing once + spin medium is selected.
- 3) Operation does not return to previous cycle even when pressing the button again. The cycle set in the corresponding course is displayed by rotating course dial. Then, rinse spin LED is turned off.
- 4) Water temperature can be selected with Temp. button after rinse + spin is set.  
Selection can be made from Cold/Cold to Warm/Warm.
- 5) Even after rinse + spin is selected, water temperature selection cannot be made in wool and drum cleaning courses.
- 6) When cycle is completed, LED is turned off.

---

#### **4-10. Extra Rinse**

- 1) Extra rinse is not available in speed wash and drum cleaning courses.
- 2) When pressing button rinsing cycle is added by once and LED is lit. When pressing button again, rinsing cycle decreases by once and LED is turned off.
- 3) Extra rinse LED is turned off when rinsing is completed.

#### **4-11. Extra Wash**

- 1) When pressing button, washing time increases by 8min in heavy duty and sanitary courses.
- 2) When pressing button, washing time increases by 5min in normal and cotton courses.
- 3) Extra wash is not available in wool, drum cleaning, delicate and speed wash courses.
- 4) Extra wash LED is turned off when washing is completed.

#### **4-12. Night Time**

- 1) When pressing button, spin speed is set as low and interim spin-drying changes from 790r.p.m to 550r.p.m.
- 2) When pressing button again, set values of interim spin-drying and main spin-drying mode courses are resumed.
- 3) LED is turned off when the cycle is completed.

---

#### **4-13. Custom Program**

1) When pressing custom button for the first time, the memorized program is loaded and shown in display window.

To identify whether it is a memorized program and if custom button has been pressed, 'CEP' and cycle time are displayed in turn in '18:88' display window.

Overall time is displayed only when cycle begins with start button.

2) When custom program is temporarily stopped and custom button is pressed again, basic cycle of normal course is set. Water level and load are set as well.

'18:88' display window shows the overall time.

3) Set values are saved when pressing start button in custom mode.

4) Custom setting is administered in the following order.

- Power on --> custom button on --> course and cycle selection --> start button on ==> saved

#### **4-14. Course Selection Switch**

1) Normal course selected by clicking switch once after power is turned on.

2) Per each click after the first, course is selected in the direction of CW or CCW.

3) 18:88 display indicates cycle time of each course.

#### 4-15. Option Button

	Temp	Spin	Soil	Beeper	Delay Wash	PreWash	Extra Wash	Extra Rinse	Rinse +Spin	Night Time	Custom Program
White	Cold/Cold~ Hot/Cold	NoSpin ~ ExtraHigh	Light~ Heavy	Off~ High	0	0	0	0	0	0	0
Wool	Cold/Cold	NoSpin ~ Low	Light	Off~ High				0	0	0	0
Delicate	Cold/Cold	NoSpin ~ Medium	Light~ Heavy	Off~ High		0		0	0	0	0
Permpress	Cold/Cold~ Hot/Cold	NoSpin ~ ExtraHigh	Light~ Heavy	Off~ High	0	0	0	0	0	0	0
Cotton	Cold/Cold~ Hot/Cold	NoSpin ~ ExtraHigh	Light~ Heavy	Off~ High	0	0	0	0	0	0	0
Normal	Cold/Cold~ Hot/Cold	NoSpin ~ ExtraHigh	Light~ Heavy	Off~ High	0	0	0	0	0	0	0
Heavy Duty	Cold/Cold~ Hot/Cold	NoSpin ~ ExtraHigh	Light~ Heavy	Off~ High	0	0	0	0	0	0	0
Bulky/Large	Cold/Cold~ Warm/Warm	NoSpin ~ Medium	Light~ Heavy	Off~ High		0	0	0	0	0	0
Sanitary	ExtraHot/C	NoSpin ~ ExtraHigh	Light~ Heavy	Off~ High	0	0	0	0	0	0	0
Speedwash	Cold/Cold~ Warm/Warm	NoSpin ~ Medium	Light	Off~ High	0				0	0	0
Drum Cleaning	Cold/Cold	NoSpin ~ Low	Light	Off~ High						0	0

## 5. MODO DE PRUEBA MANUAL

- La PCB y otras partes electrónicas pueden probarse sin llenar agua y comprobar su estado.

### 1) Proceso

: Presione encendido > mantenga presionado "WASH" mientras presiona 3 veces "SPIN" > "XXX" será mostrado encienden LED's y display> cuando presione "Beeper" 1 vez, sucederá la secuencia siguiente.

- "X X X' : Muestra la versión del programa

Step	Display		Details
1	L_C		Door Lock Close
2	run	001	Running times count
3	E5	0	E5 Error count
4	E6	0	E6 Error count
5	E7	0	E7 Error count
6	E8	0	E8 Error count
7	F		Do not use
8	H		Hot Valve on
9	C		Cold Valve on
10	P		Pre Wash Valve on
11	d		Do not use
12	b		Bleach Valve
13	dr		Drainage pump on
14	L_O		Door Lock Open

### 2) Mas detalles

- Cuando regresa a señal 'LOCK' , todos los procesos están operando normalmente.

- Para probar el motor BLDC programe exprimido o enjuague.



## 6. Notificación de Anormalidad

### 6-1. IE (Error de entrada) - Error en llenado

1) Causa

- ① En caso de no alcanzar el nivel de agua en 5 minutos durante el llenado.

2) Todos los LED's se apagan y 'IE' se muestra en el display.

3) La alarma sonará por 10 segundos cada 10 minutos.

4) El error en el display se borra al apagar la lavadora.

### 6-2. OE (Error de salida) - Error en drenado

1) Causa

- ① En caso que el nivel del agua no alcance el punto de reajuste después de 10 min. de inicio del drenado.

2) Todos los LED's se apagan y 'OE' se muestra en el display.

3) La alarma sonará por 10 segundos cada 10 minutos.

4) El error en el display se borra al apagar la lavadora.

### 6-3. UE (Error de desbalanceo)

1) Causa

- ① En caso de no alcanzar el balanceo en el exprimido principal en 20 intentos por balancear la carga.
- ② En caso que el balanceo falle en exprimido intermedio, 'UE' se muestra mientras se mueva al siguiente proceso.

2) Todos los LED's se apagan y 'UE' se muestra en el display.

3) La alarma sonará por 10 segundos cada 10 minutos.

4) El error se borra al abrir la puerta y acomodar la carga, cierre la puerta y continúe el ciclo, presione INICIO, el exprimido inicia nuevamente.

---

#### **6-4. LE (Error de Seguro) - Puerta abierta**

1) Causa

① Cuando al oprimir "INICIO" la puerta está abierta y el SW no es activado.

2) Todos los LED's se apagan y 'LE' se muestra en el display.

3) La alarma sonará por 10 segundos cada 10 minutos.

4) El error en el display se borra al apagar la lavadora.

#### **6-5. E1 - Error en nivel de agua**

1) Causa

① Si el nivel de agua es menor del nivel de reajuste o desbordamiento, se detecta en el llenado.

2) La valvula de entrada trabaja hasta que el agua alcanza el nivel de reajuste.

3) Todos los LED's se apagan y 'E1' se muestra en el display.

4) La alarma sonará por 10 segundos cada 10 minutos.

5) El error en el display se borra al apagar la lavadora.

#### **6-6. E2 - Error de Sobrellenado**

1) Causa

① Si el nivel del agua en la tina esté sobre el nivel de desbordamiento debido a la operación continua de la válvula de agua.

2) La bomba de drenado funcionará hasta que el agua esté debajo del nivel de reajuste.

3) Todos los LED's se apagan y 'E2' se muestra en el display.

4) La alarma sonará por 10 segundos cada 10 minutos.

5) El error en el display se borra al apagar la lavadora.

---

### **6-7. E4 - Fuga de agua durante el lavado**

#### 1) Causa

- ① Si el nivel de agua es menor, re-abastece hasta en 15 ocasiones, antes de terminar el calentamiento del agua.

2) Todos los LED's se apagan y 'E4' se muestra en el display.

3) La alarma sonará por 10 segundos cada 10 minutos.

4) El error en el display se borra al apagar la lavadora.

### **6-8. E9 - Sensor de Presión anormal**

#### 1) Causa

- ① En caso que la frecuencia del sensor de nivel de agua sea menor a 15KHz o mayor de 30KHz en el ciclo de lavado debido a falla del sensor.

2) Todos los LED's se apagan y 'E9' se muestra en el display.

3) La alarma sonará por 10 segundos cada 10 minutos.

4) El error en el display se borra al apagar la lavadora.

---

## 6-9. Motor-related Error

### 1) E5 (DC-Error de alto voltaje)

- ① Si el VCD en el acoplamiento IPM sube a 450V o mayor.
- ② El motor se detiene y 'E5' se muestra en el display.
- ③ La alarma sonará por 10 segundos cada 10 minutos.
- ④ El error en el display se borra al apagar la lavadora.

### 2) E6 (EMG) Error

- ① En caso de detectar una corriente de 20A o mayor en el puerto EMG
- ② El motor se detiene y 'E6' se muestra en el display.
- ③ La alarma sonará por 10 segundos cada 10 minutos.
- ④ El error en el display se borra al apagar la lavadora.

### 3) E7 (Error de Dirección)

Si la señal en HALL IC es diferente de la señal prevista según la dirección de la rotación.

- ② El motor se detiene y 'E7' se muestra en el display.
- ③ La alarma sonará por 10 segundos cada 10 minutos.
- ④ El error en el display se borra al apagar la lavadora.

### 4) E8 (Error al iniciar operacion)

- ① Si la señal de entrada del Hall IC es anormal debido a problemas en conector del motor.
- ② El motor se detiene y 'E8' se muestra en el display.
- ③ La alarma sonará por 10 segundos cada 10 minutos.
- ④ El error en el display se borra al apagar la lavadora.

## 6-10. Error en Sensor deTemperatura

### 1) H2 Error en sensor de temperatura de lavado

- ① Sensor de temperatura de lavado abierto o en corto.
- ② La alarma sonará por 10 segundos cada 10 minutos.
- ③ El error en el display se borra al apagar la lavadora.

### 2) H4 Error de sobrecalentamiento en lavado.

- ① Si la temperatura de lavado detectada por el sensor es de 95°C o mayor.
- ② La alarma sonará por 10 segundos cada 10 minutos.
- ③ El error en el display se borra al apagar la lavadora.

---

3) H5 Error en la temperatura para ciclos de lana y delicados.

- ① Si la temperatura del agua en ciclo de lana o delicados es de 45°C o mayor.
- ② La alarma sonará por 10 segundos cada 10 minutos.
- ③ El error en el display se borra al apagar la lavadora.

4) H6 Error en Calefactor de Lavado.

- ① Después de 15 min. inicia la operación del calefactor.  
Si la temperatura es de 42°C o menor y no aumenta en 2 °C o más. En caso de que la temperatura sea de 42 °C o mayor y no aumenta 1 °C o más.
- ② Si la temperatura baja 2°C o más debido a un reajuste en el nivel de agua, etc. la temperatura y el tiempo de 15 min. para señalar el error se reajustan.
- ③ La alarma sonará por 10 segundos cada 10 minutos.
- ④ El error en el display se borra al apagar la lavadora.

5) H8 Error de sobrecalentamiento en lavado

- ① Si la temperatura del calefactor de lavado se incrementa 5°C o más en un lapso de 30 sec. sin agua en el tambor.
- ② La alarma sonará por 10 segundos cada 10 minutos.
- ③ El error en el display se borra al apagar la lavadora.

6) PFE (Error en filtro de bomba)

- ① El ciclo se brinca al siguiente paso cuando no alcanza el 70 % de r.p.m. durante el exprimido intermedio.
- ② El programa puede balancear la carga en el exprimido cuando alcanza el 70% de las r.p.m de la velocidad seleccionada durante el exprimido principal.
- ③ 'PFE' error ie causado cuando el tiempo de drenado se incrementa.
- ④ El error en el display se borra al apagar la lavadora.

# PCB PIN ARRANGEMENT

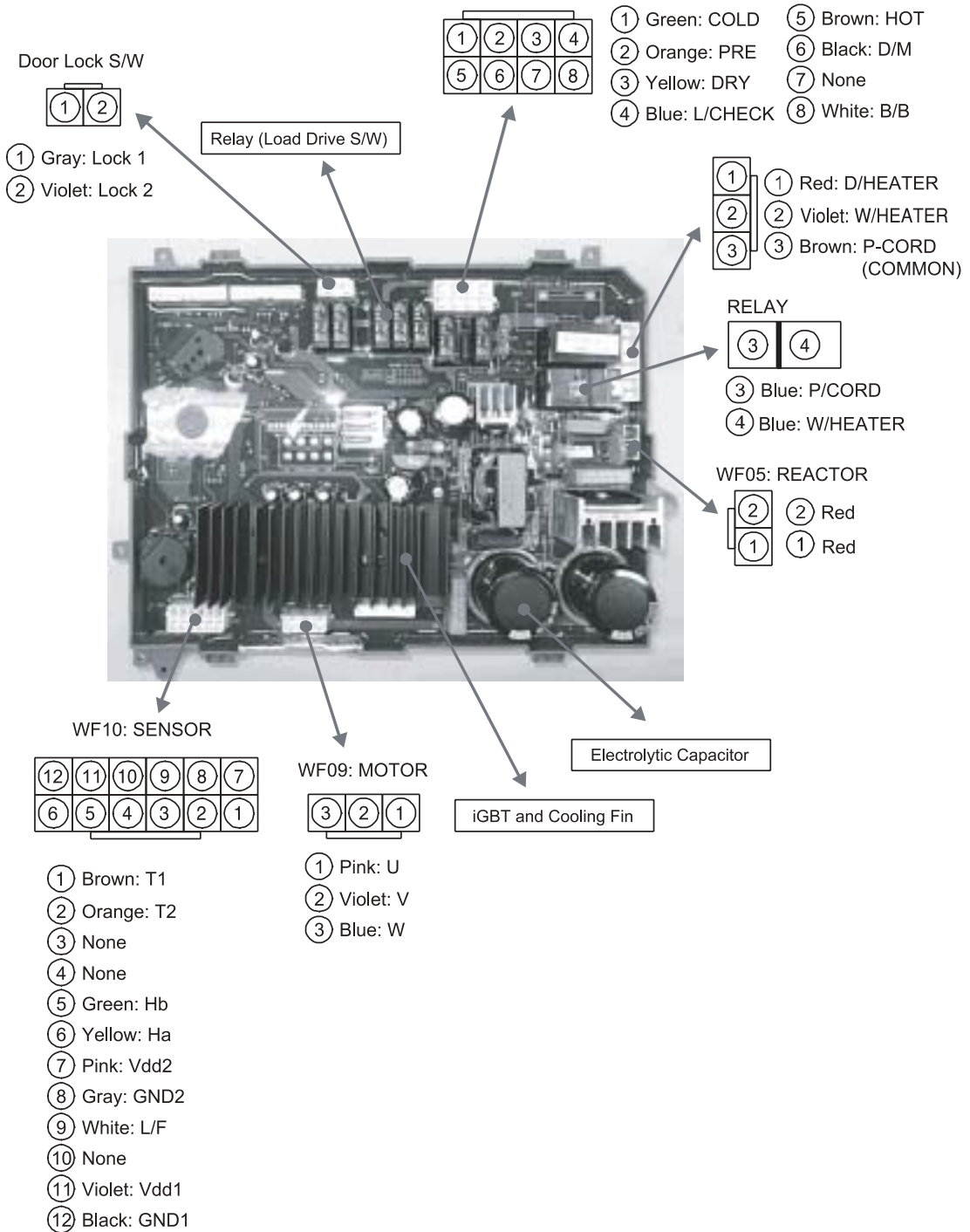

# ■ Electronic Parts List Spec.

## 1. VALVE INLET

Classification	3-hole Valve and Hot Water Valve				
Code	3-hole: 3615416940, Hot Water: 3615416700				
Color	Gray				
Coil Resistance	4320 ~ 5280 Ω				
Use	Supplying water for washing/ pre-washing and bleach				
Appearance Structure	<p style="text-align: center;">Bleach Input Valve</p> 				
Symptoms of Breakdown	Detailed Symptoms	Cause	Diagnosis of Defect	Solution	PCB Error Mode
Water not supplied	Water supply not carried, only noise is heard	Water tap not opened	Check for tap opening.	Open water tap.	"IE"
		Coil short	Check if resistance between water supply valve terminals is within 4320-5280Ω.		"IE"
		Excessive foreign substances in SUS filter	Remove water supply hose and check for foreign substances in filter.	Clean out foreign substances from inside the filter.	"IE"
	Water supply not carried out without noise	Foreign substances in valve	-		Replace water supply valve.
Connector loosened		Visually check connector connection status.		Administer re-insertion.	"IE"
Coil short		Check if resistance between water supply valve terminals is within 4320-5280Ω.		Replace water supply valve.	"IE"
Water is continuously supplied (inside tub)	Continuous water supply in power 'on' state	Wiring short	Wiring short → Conduction test		"IE"
		Defect in water level sensor	Refer to water level sensor defect check method.	Replace water level sensor.	"E2"
	Defect in pressure hose	Check for blocking of holes in pressure hose.	Replace defect parts.	"E2"	
Others	Water leakage through sides	Continuous water supply in power 'off' state	-	Replace water supply valve.	-
		Defect in water supply valve assembly, etc.	Check for leakage through the sides of water supply valve.	Replace water supply valve.	-

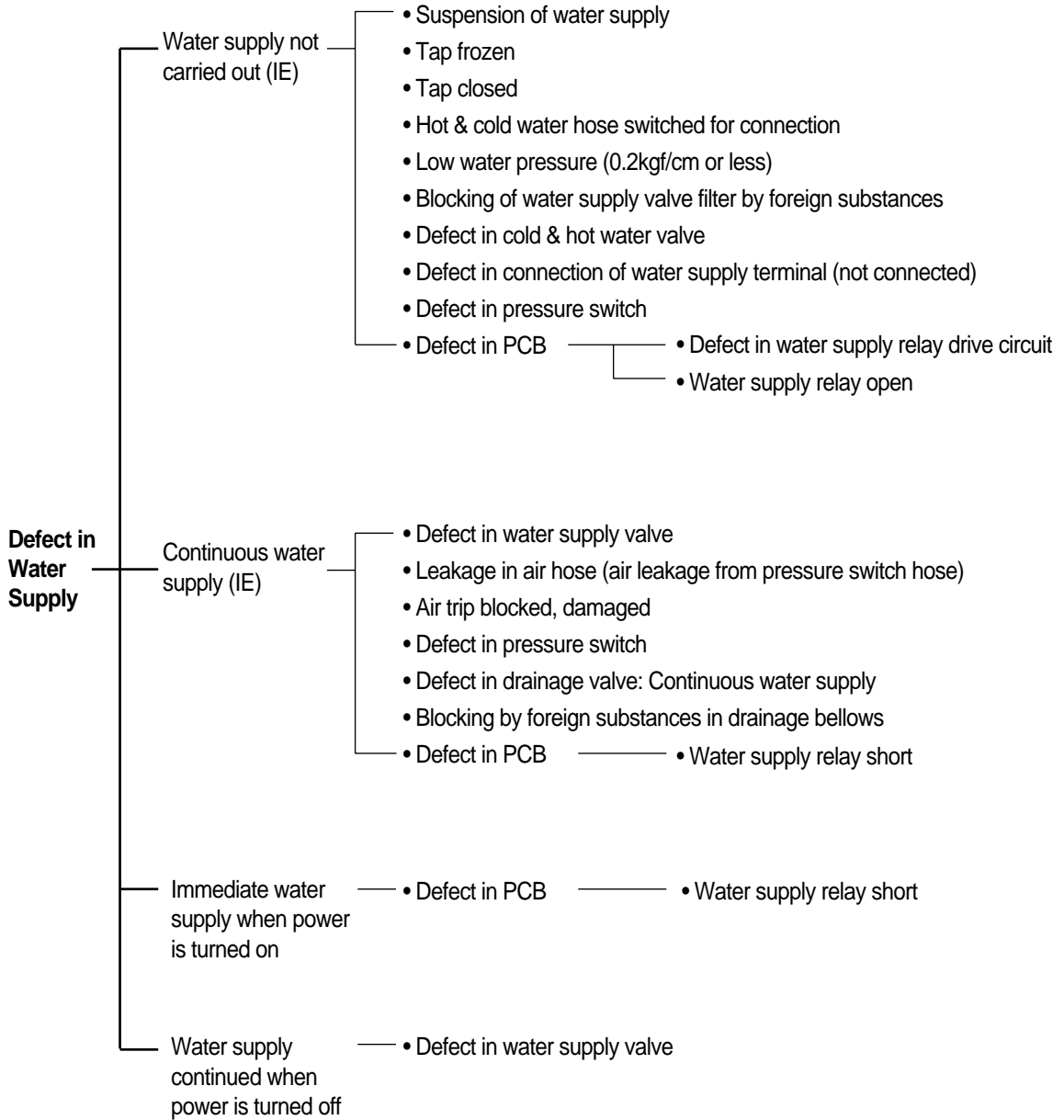



Symptoms of Breakdown	Inspection Spot	Inspection Method	Inspection Result	Problem Identified	Repair Method
Water supply not carried out		1) Suspension of water supply 2) Water tap locked 3) Cold-hot water hose incorrectly connected 4) If no defect is found, dismantle water supply hose and check water supply valve filter.	- Cold/ hot water hose switched -Large amount of rust, sand and dust, etc.	-Defect in cold/ hot water hose assembly -Defect in cleaning of water supply filter (blocked)	-Assemble cold/ hot water hose correctly. -Clean water supply filter.
	Water supply valve	1) Measure coil resistance in water supply valve. 2) Remove top cover and visually check for separation of water supply valve terminal connector and wiring short/ connection status. 3) In case water valve operation sound is heard, but water supply is not carried out, check for blocking of water supply valve or restraint on plunger.	-5.3kW or higher  -Connector loosened/ not inserted  -Electric wire short -Sound and defect in water supply due to foreign substances in bellows	-Coil short  -Connection defect  -Electric wire short -Structural defect in water supply valve	-Replace water supply valve. -Try reconnection or remove elements of connection defect.  -Try reconnection or remove elements of connection defect. -Replace water supply valve.
	Pressure Switch	1) Check for 'E9' in display window.	-E9	-Loosening of pressure S/W terminal or electric wire short -Defect in pressure S/W	-Connect terminal of pressure S/W. -Connect terminal of PCB. -Replace pressure S/W.
Water supply not carried out	PCB	1. Check PCB pin connector insertion status. 2. Power is supplied to water supply valve terminal, but water supply is not administered.	Electric wire easily loosened when tugged PCB water supply circuit open, damaged (water supply relay operation not carried out)	Pin connector housing not inserted Defect in water supply circuit	Completely insert connector housing. Replace PCB.
Continuous water supply	PCB	1. Immediate supply when power is turned on	PCB water supply circuit or relay short (continuous conduction to valve)	Water supply relay short	Replace PCB.
	Water supply valve	1. Check if water supply is continuously carried out even if power is not on.	Water supply bellows blocked/ deformed	Defect in water supply valve	Replace water supply valve.
	Drainage drive motor (valve housing)	1. Check for normal operation of water supply valve/ water supply status. 2. Check if water is drained through drainage hose. 3. Check for foreign substances inside valve housing. 4. Check for foreign substances in drive motor wire. 5. Forcefully restore SUS wire.	-Not closed due to foreign substances inside drainage housing -Wire caught by foreign substances outside drive motor -Forced restoration not possible	-Foreign substances in valve housing -Foreign substances -Defect in drive motor restoration	-Remove foreign substances. -Remove foreign substance. -Replace drive motor.

## 2. Water Level Sensor

### 1) Spec. of Water Level Sensor

<p>O/F: Forced drainage is necessary as water level is high. When this level is reached, water supply must be stopped and drainage must be forcefully administered.</p>	<p>RESET :</p> <ol style="list-style-type: none"> <li>Spin-drying begins 30sec after drainage level reset is reached.</li> <li>Heater operation level</li> </ol>	<p>Low: Small load of laundry, therefore considered to be water level of 'low'</p>
		<p>Medium: Large load of laundry</p>
		<p>Medium High: Water level for rinsing</p>
		<p>Safety: Door open possible Door opened only when water level is below safety level</p>

Model	Code	Classification	O/F	Medium High	Medium	Low	Safety	Reset	Initial(Defect)	Inlet Angle
WD1132	3614825220	Frequency	22.60kHz	23.10kHz	23.20kHz	24.00kHz	24.40kHz	24.70kHz	25.80kHz	90°
	DN-DD03, DL-DW03	Water level (mm)	260 ± 15	225 ± 15	220 ± 7	170 ± 15	140 ± 15	120 ± 20	0	

### 2) Breakdown Analysis

Symptoms	Detailed Symptoms	Cause	Diagnosis	Solution	PCB Error Mode
Continuous water supply	Water valve normal	Defect in pressure sensor hose	Check for holes.	Replace hose.	"E2"
		Blocking of pressure sensor hose	Visual checking	Remove foreign substances.	"E2"
"E9"	Occurrence in water level sensor 30kHz or higher	Connector loosened	Visually check connector connection status.	Administer re-insertion.	"E9"
		Wiring short	Wiring short -> conduction test		"E9"

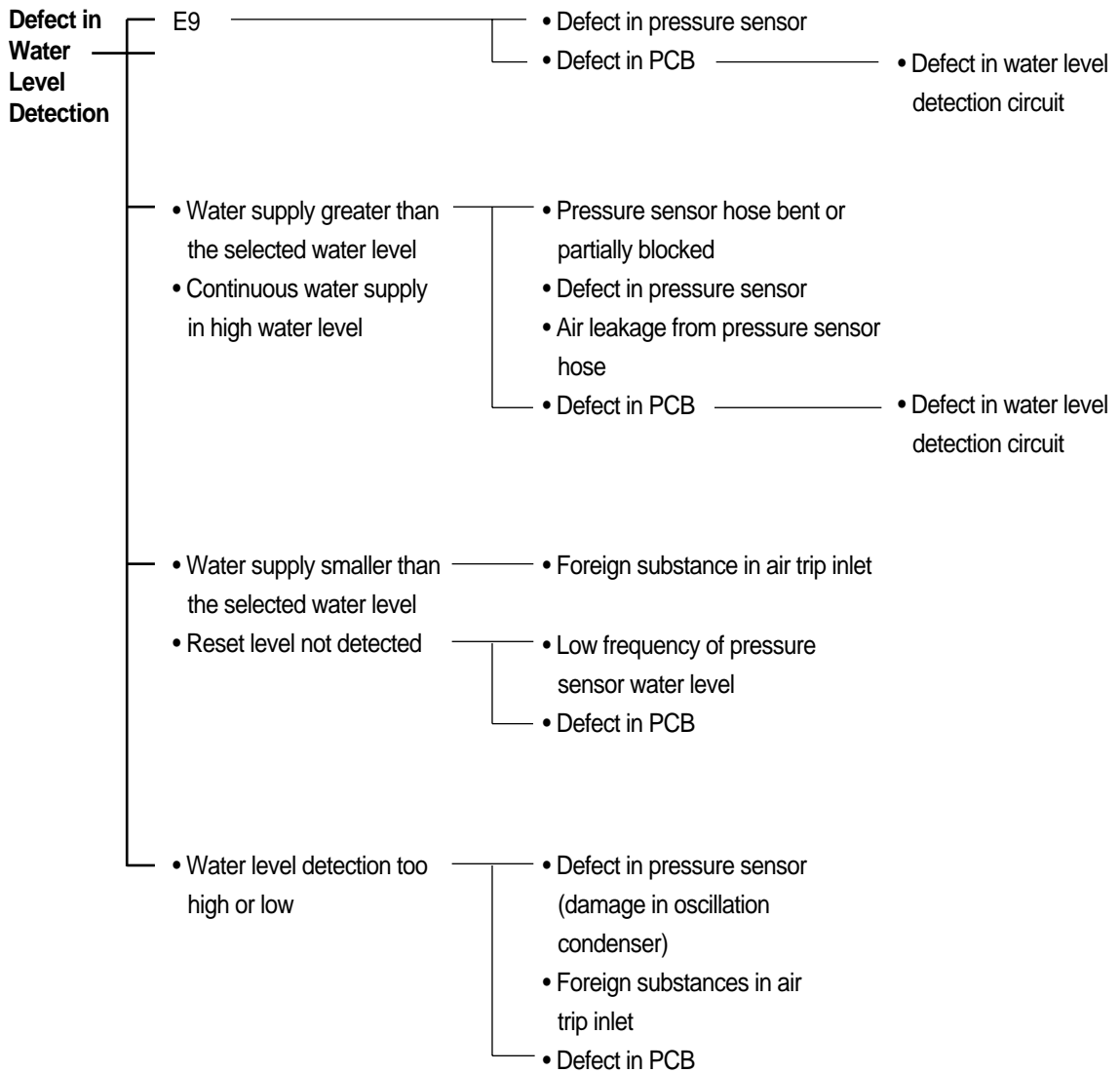

### 3. POWER CORD

Classification	Rated	Cord Thickness	Color	Code	Type	Length	Remarks
DEC	250V/15A	1.5sq	Gray	3611340430	LP-31 SJT	2.3m	-

#### 1) Assembly

- . 4 embossed parts in cabinet
- > To prevent loosening after assembly

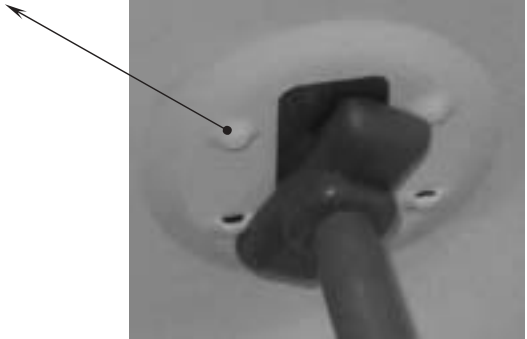

[Before]



[After]

#### . CONNECTOR

- > #1806 Housing 3P Used: Using both ends only and not the hole in the middle (materials highly resistant to flame)
- > To prevent fire caused by high current

## 4. DOOR LOCK S/W

### 1) Comparison of Door Lock S/W Spec.

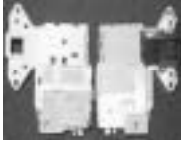
TYPE	CODE	MODEL	RATED	LOCK ON PRINCIPLE	LOCK 'ON'/'OFF' TIME	LOCK OFF TYPE	EXTERNAL APPEARANCE
DF F01 007	3619046410	WD1132	125V 16A	Bimetal operation by PTC heating	-ON : Min. of 6sec -OFF after Cooling in Air: 40sec ~ 5min -Forced OFF: Immediate OFF (door opening) bimetal	1. Forced OFF by solenoid 2. Natural OFF by cool down of	

### 2) Structure and Spec. of Door Lock S/W: DF SERIES

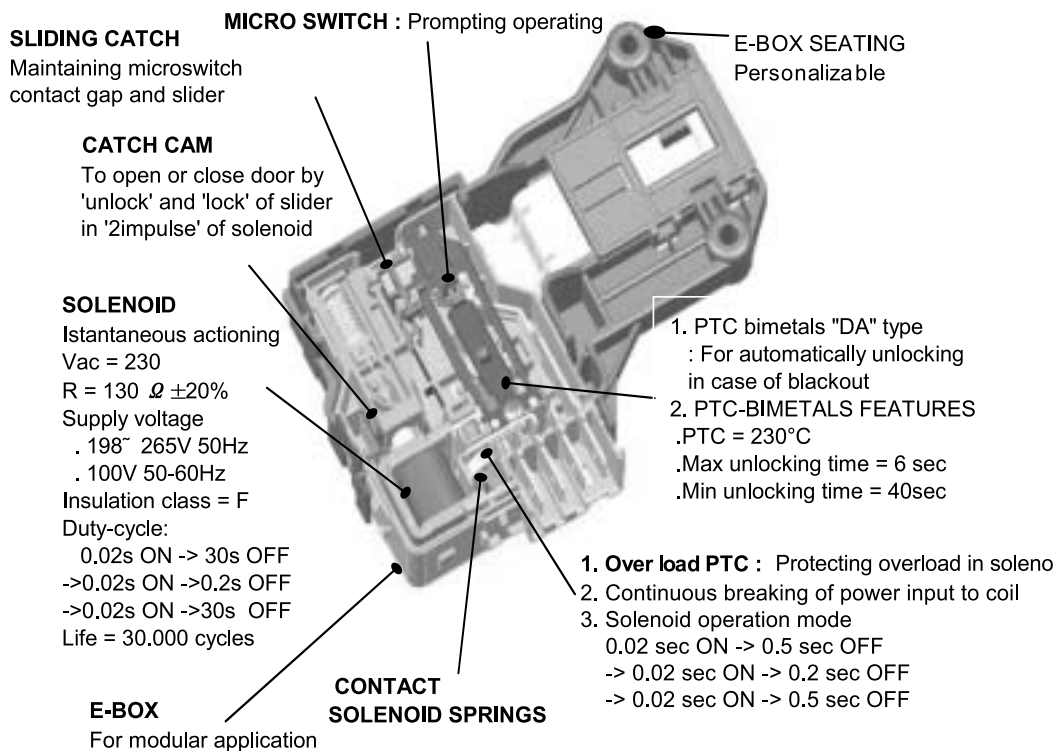

**\* How to Replace Door Lock Switch**

- 1) Open door and dismantle clamp spring for gasket.
- 2) Dismantle gasket.
- 3) Loosen 2 screws for door lock S/W.
- 4) Remove door lock S/W.
- 5) Administer assembly in reverse order.

**\* Checking Solenoid Wiring of Door Lock Switch**

PIN  
Arrangement

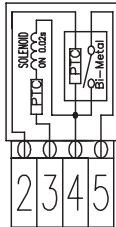
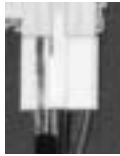

2 3 4 5  
(1 does not exist.)

Terminal 3 and 4:  
Normal if 156 ~ 234

**\* DF Door Lock S/W Operation**

Symptoms	Detalle de Sintoma	Cause	Diagnostico o Defecto	Solution	Error Mode
Ruido Tic-tac	Al iniciar operación y en pausa cuando el nivel de agua es bajo se oye un tic-tac	Ruido normal	Sonido ocasionado durante la operacion del solenoide al deslizarse el disco de la leva para liberar o bloquear la puerta		–
LE'	Ruido de tic-tac y el display muestra 'LE'	Conector zafado	Revise el estado del conector del SW de puerta	Inserte conector.	"LE"
		Terminal zafada del conector	Ver desarme del SW y revisar conexión de terminales	Inserte terminal del S/W 4 o 5	"LE"
		Puerta no cierra completamente	- Revise estado de la puerta o posible obstrucción	Cierre bien la puerta	"LE"
		Daño en gancho de puerta	-	Cambie gancho	"LE"
		Defecto en operación de leva reten	Constante ruido de 'tic tac' anormal del bloqueo y desbloqueo de puerta	Cambie S/W.	"LE"
	1. 'LE' se muestra en panel sin ruido de 'tic-tac'	Conector zafado	Compruebe visualmente el estado del conector del SW	Corrija conexión.	"LE"
		Terminal zafada del conector	Ver desarme del SW y revisar conexión de terminales	Inserte terminales del S/W 2 o 3	"LE"
		Bobina del solenoide rota	Revise resistencia (ver página anterior)	Cambie S/W.	"LE"
	Puerta no abre.	Falla de energía durante la operación	Si falla la energía durante la operación el S/W queda bloqueado, la PCB MICOM' no puede abrir la puerta. debe esperar como max. 5 min.		
Sin haber falla de energía.		Agua en tambor	Revise si el nivel de agua está arriba del nivel de seguridad	Puerta abre después de drenar	–
	Others	Door does not open normally in case of loosening of connector/ terminal and breaking of solenoid coil during operation. Administer measures after test according to the following method.			

## 5. CALEFACTOR

### 1) Especificaciones calefactor lavado

Classification	Wahing
Maker	IRCA
Voltaje	120V
Potencia	1000W $\pm$ 5%
Power	
Resistencia	25.47ohm
Current Density	8.9
Fusible de Temp.	184 °C
Thermister	Heater built-in
MaterialSUS430	
Max. Temp.	Water
Part Code	3612801740

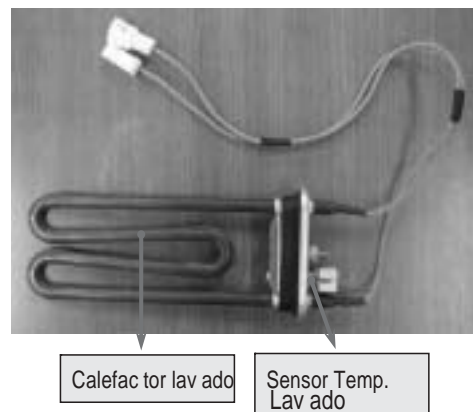

Fusible de Temperatura de lavado (184 °C No se reestablece)

: Localizado dentro del calefactor para prevenir fuego, en caso de calentamiento sin agua en tambor, en caso de falla en sensor de nivel.

: Abre aprox. en 1min si la temperatura del calefactor alcanza los 270 °C

: Indica que el calefactor funcionó sin agua en tambor.



## 2) Diagnóstico

Síntoma de falla	Causa	Diagnóstico	Solución	PCB Error
En ciclo de lavado no funciona calefactor	Arnés en corto	Revise arnés	Repare arnés	"H6"
	Calefactor de lavado o fusible abierto	Revise la resistencia de 23.5~25.7 ohms en las terminales del calefactor de lavado	Cambie el calefactor	"H6"
	Conector o terminal zafada	Revise conexiones	Inserte terminal.	"H6"
	Sensor de temperatura del calefactor dañado	Mida la resistencia entre las terminales del sensor:	Cambie el sensor.	"H2"
Calentamiento excesivo	Sensor de temperatura del calefactor dañado	Mida la resistencia entre las terminales del sensor:	Cambie el sensor.	"H2" or "H4"

### Heater Replacement

#### \* How to Replace Washing Heater and Temp. Sensor

1. Dismantling Connector



2. Loosening Earth and Heater Nuts



3. Replacing Heater and Temp. Sensor



4. Administer assembly in reverse order and make sure to fasten heater nuts first before the earth nuts.

## 6. BLDC Motor

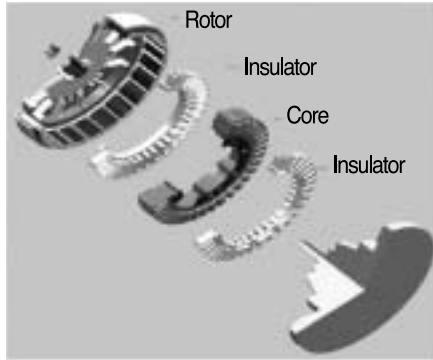

BLDC MOTOR

## 7. Power Transmission System of BLDC Motor

Magnetic density flow of BLDC Motor

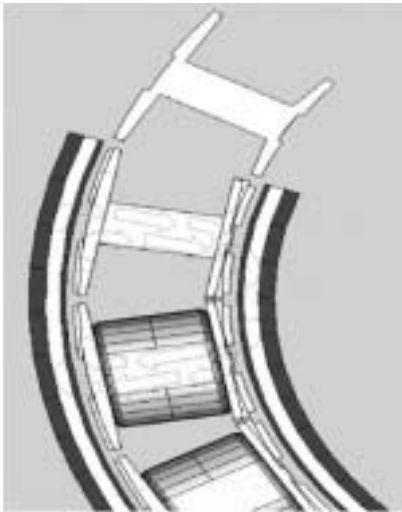

Sequence diagram of BLDC MOTOR

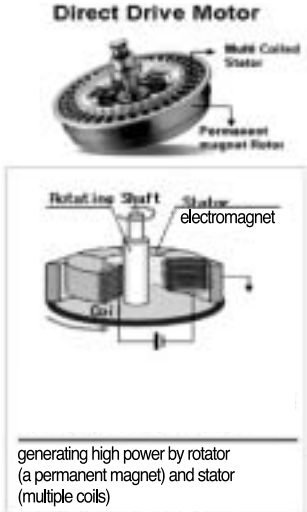
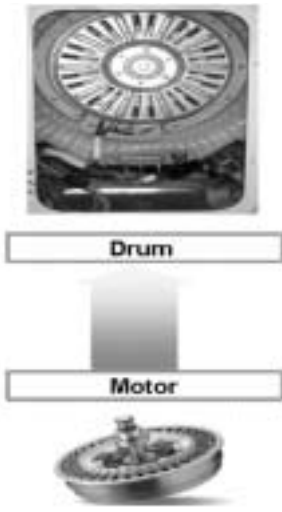

## 8. Spec.

Classification	Item	BLDC : DD Motor
1. General	Rated Voltage	$V_m = 310$ [Vdc], Hall IC Voltage 5 [Vdc]
	Insulating Structure	Type B, insulator method
	External Appearance	Shaft connection and stator connection structure, Air-gap : 1mm
	No. of Poles	24 poles, Core: 36 slots, Layer: [30mm]
2. Performance	Consumption Power	390[W] $\pm$ 10[%], during washing (picked value)
	RPM	During Washing: 45RPM, During Spin-drying:1300RPM
	Output Characteristics	Torque: 300Kgf.cm (washing: 45rpm) Current: 1.5A (washing: 45rpm), 2.5A (spin-drying: 800rpm) AC Input Terminal - Washing: 250Wo, Spin-drying: 380Wo
3. Structure	Stator Resistance	$\phi 265 \times 30H$
		U(blue) - V(purple) : 13.8 $\Omega$ [at 75°C] V(purple) - W(pink) : 13.8 $\Omega$ [at 75°C] W(pink) - U(blue) : 13.8 $\Omega$ [at 75°C] cf) Motor resistance at ambient temp. of 0 ~ 35°C 7.04 ~ 8.1 $\Omega$
	Rotor	Magnet : 24 segments, bracket, serration
	Hall IC	2-sensor Control Type, Top Central Angle: 7.5 degrees Signal Error Angle (phase difference): 90 $\pm$ 5 degrees (based on electric angle)

## 9. Sistema de drenado

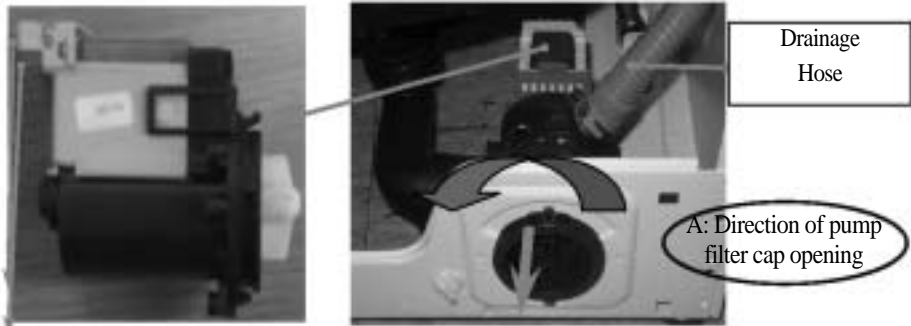

Wire connection terminal Pump filter

### Problemas en drenado

No drena (OE)

- Bomba obstruida
- Bomba congelada
- Operación defectuosa de bomba
- Manguera de dreando doblada
- Instalación de drenado bloqueado
- Demasiado alto el desagüe
- Drenaje congelado
- Terminal de bomba zafada
- Bomba con baja eficiencia
- Defecto en PCB ——— • Relay de bomba dañado

Drenado normal pero OE se muestra en display

- Defecto ein sensor de presión (frecuencia de oscilación baja)
- Daño en control ——— • Defecto en circuito de oscilación

## ■ Power Defect

---

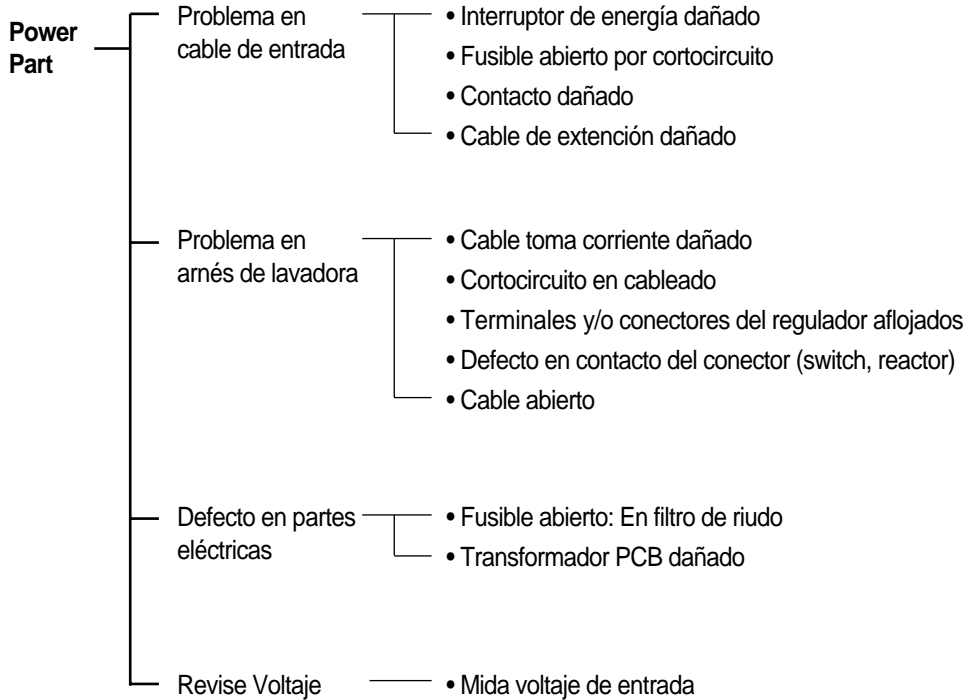

# ■ RUIDOS

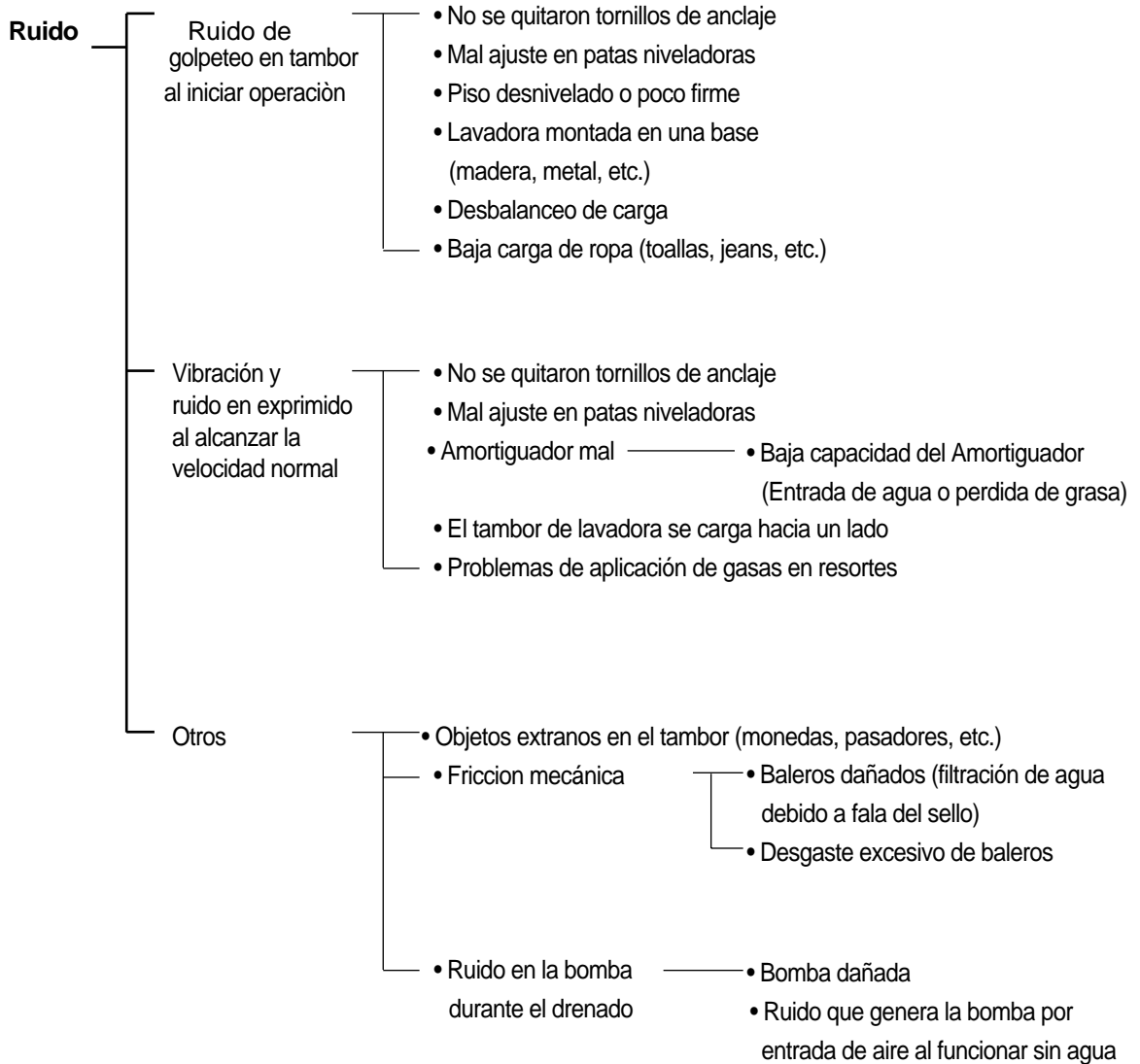

# ■ Wiring Diagram

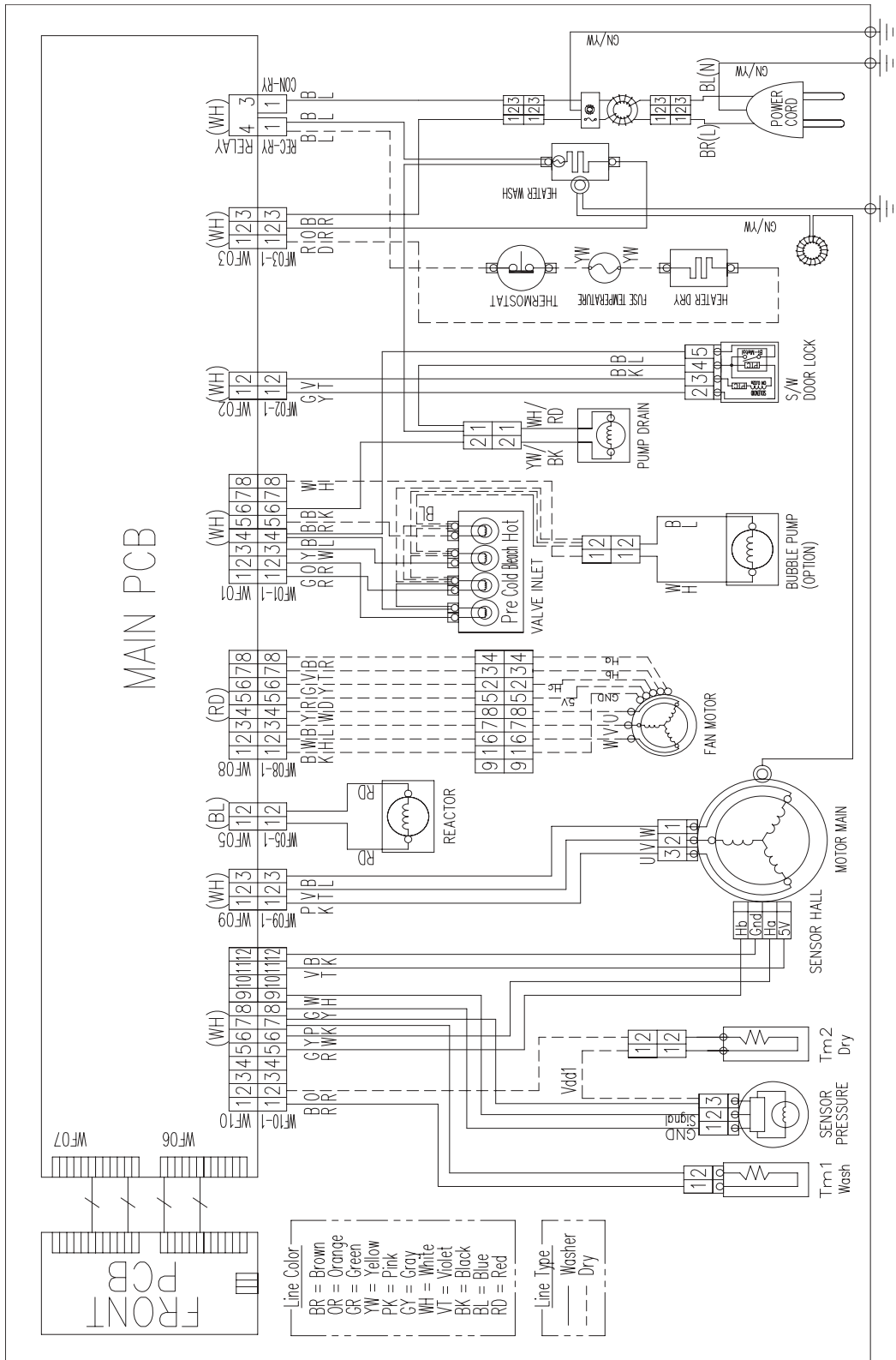

# ■ Installation

## 1) Related Parts and Configuration

Item	Configuration	Remarks
FIXTURE UP / DOWN AS		SPECIAL SCREW UP : L= 109mm  SPECIAL SCREW DOWN :L=160mm
UNIT SERVICE WRENCH		① FIXTURE UP/DOWN AS를 제거시 사용한다.  ② LEG를 조절할 때 사용한다.
LEG ADJUST AS		

## 2) Installation Procedures

① Remove fixture up/ down AS.

Removal	Remarks
	<ul style="list-style-type: none"> <li>☞ Remove fixture up/down AS by rotating it in anti-clockwise direction.</li> <li>☞ Store fixture up/down for use later on.</li> <li>☞ To assemble fixture up/down AS, rotate it in clockwise direction.</li> </ul>



② Insert cap holder (4) into holes created after removing fixture up/down AS as shown in the picture.

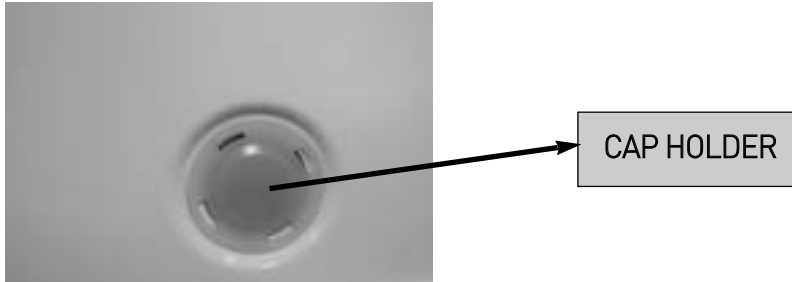

③ Install drum washing machine on flat and solid ground.

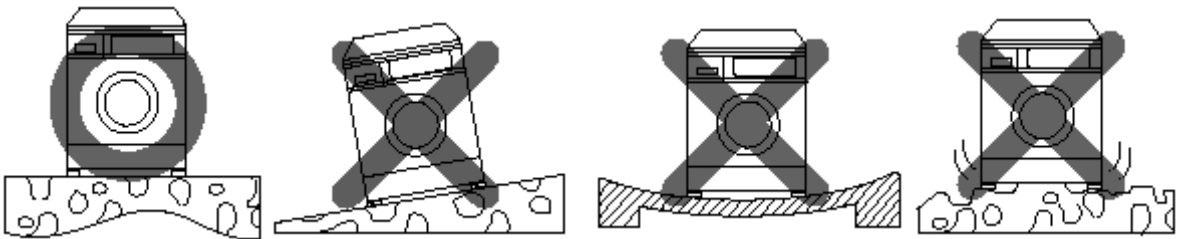

④ Adjust leveling with led adjust AS.

Adjustment	Remarks
	<ul style="list-style-type: none"> <li>☞ Washing machine is moved upwards by rotating foot of leg adjust AS in clockwise direction.</li> <li>☞ Washing machine is moved downwards by rotating foot of leg adjust AS in anti-clockwise direction</li> </ul>

⑤ Adjust fixture leg to fasten special bolt.

Adjustment	Remarks
	<ul style="list-style-type: none"> <li>☞ Vibration of washing machine is suppressed by rotating fixture leg in anti-clockwise direction as it fastens special bolt.</li> </ul>

## DEPÓSITO DE JABÓN

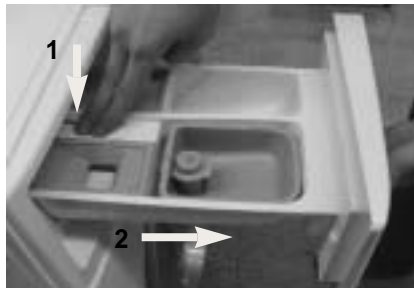

## PANEL FRONTAL

1. Retire 2 tornillos
2. Remueva panel F.
3. Remueva conector.
4. Cuidado de no dañar el gancho.

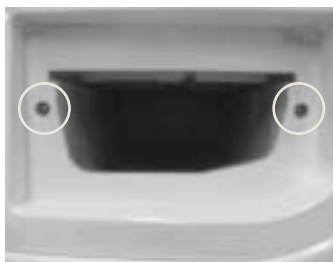

# TAPA SUPERIOR

1. Retire 3 tornillos



2. Retire 4 tornillos

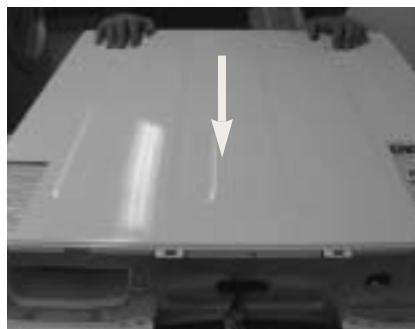

# CAJA JABONERA

1. Retire 4 abrazaderas.



2. Remueva y separe manguera.



# VÁLVULAS

1. Retire 4 tornillos.

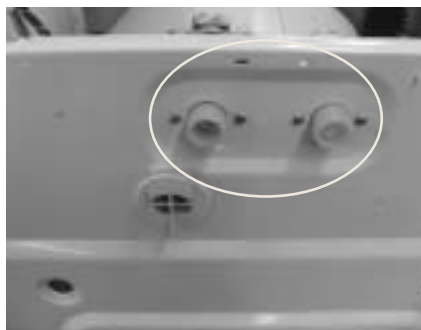

2. Separe 3 conectores.

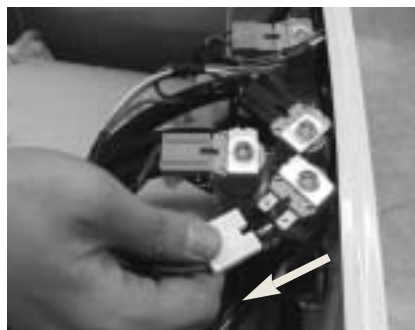

3. Retire 3 abrazaderas.

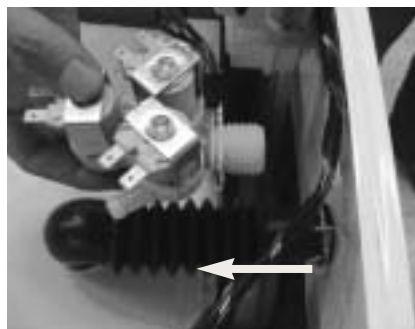

# PCB PRINCIPAL

1. Separe arnés y tapa de PCB.

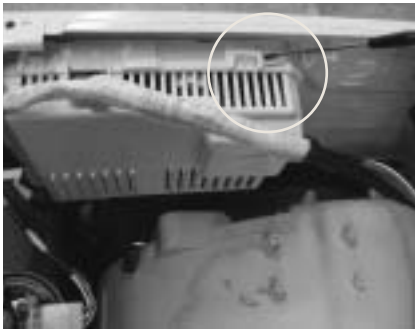

2. Separe conector.

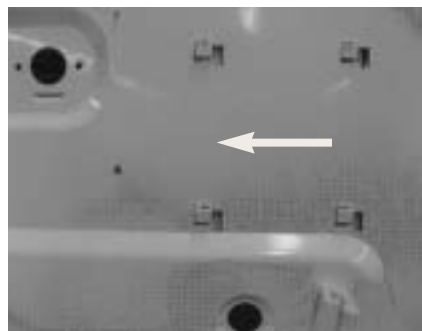
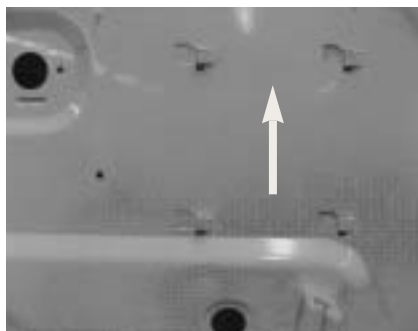

## SENSOR NIVEL DE AGUA

1. Retire 1 tornillo. .



2. Separe conector.



3. Separe manguera del sensor de presión.



## TAPA TRASERA

1. Retire 4 tornillos.



## MOTOR

1. Retire el tornillo que sujeta el rotor.
2. Remueva el motor quitando los 6 tornillos del estator. (Cude de no dañar las bobinas)

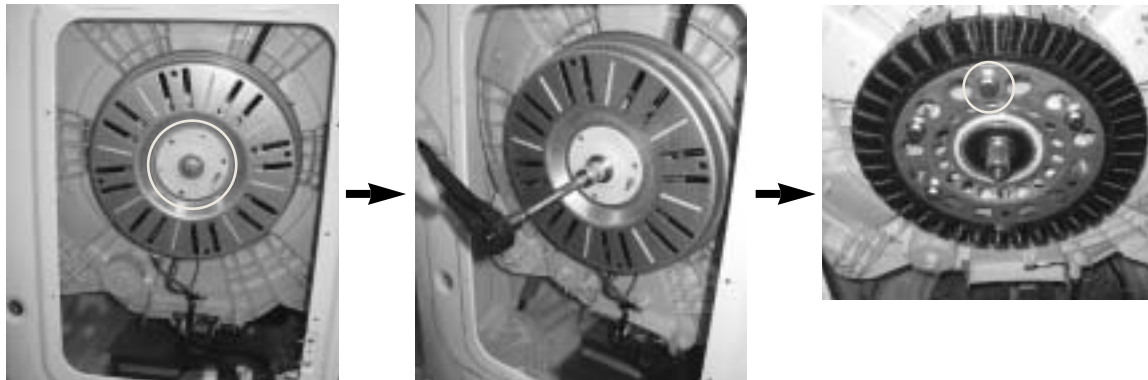

## CALEFACTOR DE LAVADO

1. Retire la tuerca.
2. Remueva el conector.
3. Remueva calefactor en dirección de la flecha.



## AMORTIGUADORES

1. Presione los bordes delgados del seguro del amortiguador.
2. Retire el amortiguador.





3. Quite el seguro del amortiguador de la tina del mismo modo.



## DESENSAMBLE DE FILTRO

1. Empuje el filtro en dirección de la flecha y jale hacia arriba.

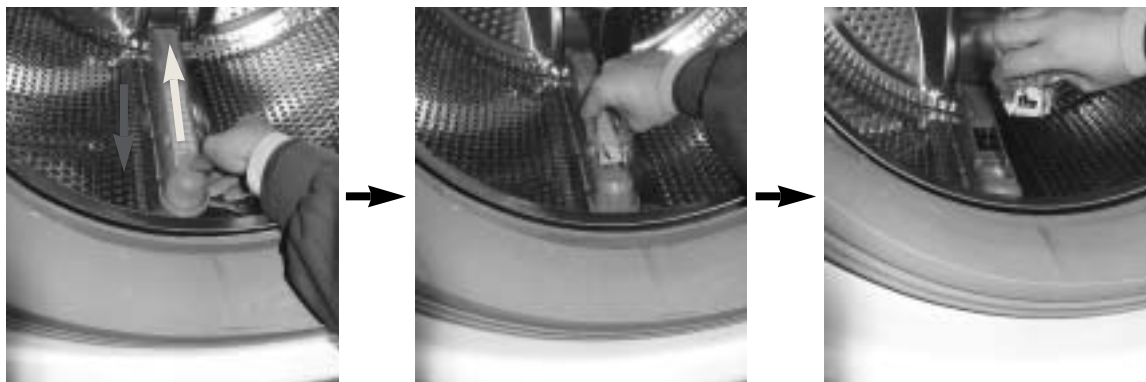

# GABINETE FRONTAL

1. Remueva la abrazadera del gasket.

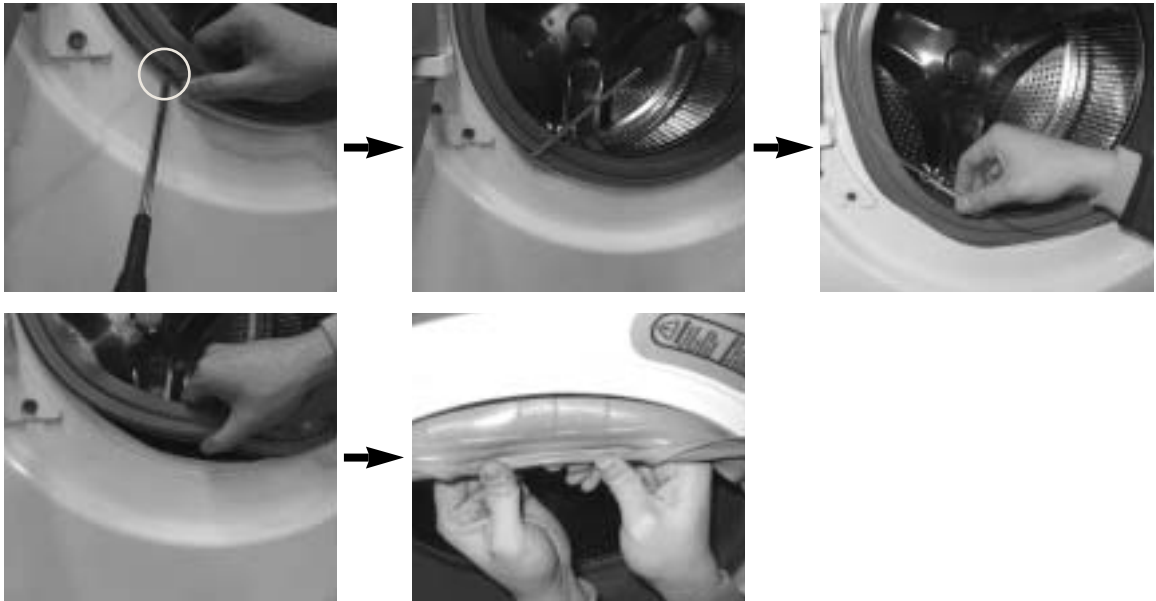

2. Retire 4 tornillos.



3. Levante el frente en dirección de la flecha y jale hacia adelante .  
4. Separe el conector del seguro de puerta.

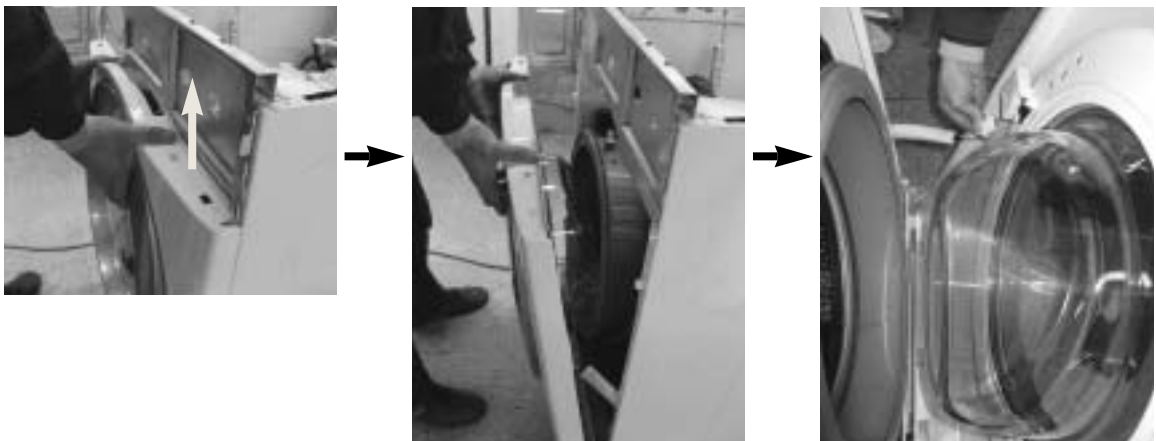

# BOMBA DE DRENADO

1. Remueva la abrazadera.



2. Retire 1 tornillo.



3. Desconecte.



4. Retire la bomba en dirección de la flecha.



## SWITCH DE PUERTA

1. Retire 2 tornillos y separe el switch de la puerta.

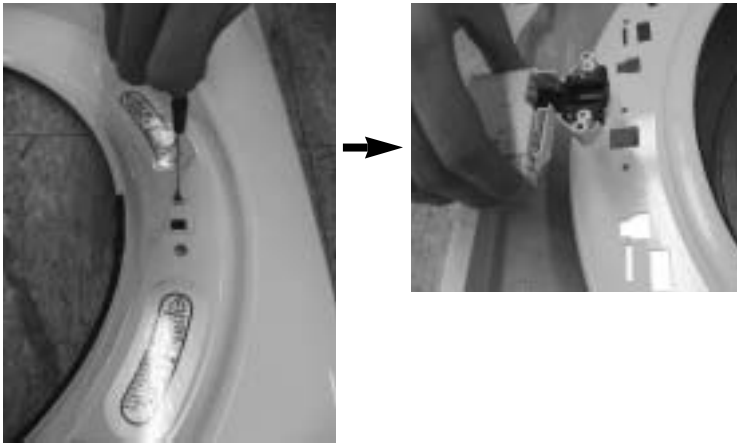

## PUERTA

1. Remueva 4 tornillos.



2. Desmantele la puerta retirando los tornillos del marco.



# TINAS

1. Separe los contrapesos de balanceo quitando 8 tornillos.



2. Quite el tornillo del gasket.

3. Separe el ensamble motor.



4. Separe el tubo frontal después de quitar los 16 tornillos que lo sujetan.

