

# AV RECEIVER RX-V596/HTR-5250 RX-V596RDS SERVICE MANUAL

## IMPORTANT NOTICE

This manual has been provided for the use of authorized YAMAHA Retailers and their service personnel. It has been assumed that basic service procedures inherent to the industry, and more specifically YAMAHA Products, are already known and understood by the users, and have therefore not been restated.

**WARNING:** Failure to follow appropriate service and safety procedures when servicing this product may result in personal injury, destruction of expensive components, and failure of the product to perform as specified. For these reasons, we advise all YAMAHA product owners that any service required should be performed by an authorized YAMAHA Retailer or the appointed service representative.

**IMPORTANT:** The presentation or sale of this manual to any individual of firm does not constitute authorization, certification or recognition of any applicable technical capabilities, or establish a principle-agent relationship of any form.

The data provided is believed to be accurate and applicable to the unit(s) indicated on the cover. The research, engineering, and service departments of YAMAHA are continually striving to improve YAMAHA products. Modifications are, therefore, inevitable and specifications are subject to change without notice or obligation to retrofit. Should any discrepancy appear to exist, please contact the distributor's Service Division.

**WARNING:** Static discharges can destroy expensive components. Discharge any static electricity your body may have accumulated by grounding yourself to the ground buss in the unit (heavy gauge black wires connect to this buss).

**IMPORTANT:** Turn the unit OFF during disassembly and part replacement. Recheck all work before you apply power to the unit.

## ■ CONTENTS

TO SERVICE PERSONNEL .....	1	AMP ADJUSTMENT .....	21
REMOTE CONTROL PANELS .....	1	TUNER ADJUSTMENT .....	22~25
FRONT PANELS .....	2	IC DATA .....	26~34
REAR PANELS .....	3~4	DISPLAY DATA .....	35
SPECIFICATIONS .....	5~6	BLOCK DIAGRAM .....	36~39
INTERNAL VIEW .....	7	PRINTED CIRCUIT BOARD .....	40~59
DISASSEMBLY PROCEDURES .....	7	SCHEMATIC DIAGRAM .....	60~67
SELF DIAGNOSIS FUNCTION .....	8~19	PARTS LIST .....	68~86
FACTORY PRESET .....	20	REMOTE CONTROL TRANSMITTER .....	87~88



このサービスマニュアルは、エコマーク認定の再生紙を使用しています。  
This Service Manual uses recycled paper.



## TO SERVICE PERSONNEL

### 1. Critical Components information

Components having special characteristics are marked  $\triangle$  and must be replaced with parts having specifications equal to those originally installed.

### 2. Leakage Current Measurement (For 120V Model only)

When service has been completed, it is imperative that you verify that all exposed conductive surfaces are properly insulated from supply circuits.

- Meter impedance should be equivalent to 1500 ohm shunted by 0.15 $\mu$ F.
- Leakage current must not exceed 0.5mA.
- Be sure to test for leakage with the AC plug in both polarities.

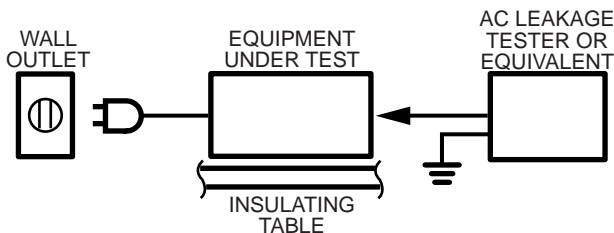

### "CAUTION"

"F802: FOR CONTINUED PROTECTION AGAINST RISK OF FIRE, REPLACE ONLY WITH SAME TYPE 8.0A, 125V FUSE."



### ATTENTION

F802: UTILISER UN FUSIBLE DE RECHANGE DE MEME TYPE DE 8.0A, 125V FUSE

## WARNING: CHEMICAL CONTENT NOTICE!

The solder used in the production of this product contains LEAD. In addition, other electrical/electronic and/or plastic (where applicable) components may also contain traces of chemicals found by the California Health and Welfare Agency (and possibly other entities) to cause cancer and/or birth defects or other reproductive harm.

DO NOT PLACE SOLDER, ELECTRICAL/ELECTRONIC OR PLASTIC COMPONENTS IN YOUR MOUTH FOR ANY REASON WHATSOEVER!

Avoid prolonged, unprotected contact between solder and your skin! When soldering, do not inhale solder fumes or expose eyes to solder/flux vapor!

If you come in contact with solder or components located inside the enclosure of this product, wash your hands before handling food.

## REMOTE CONTROL PANELS

### ▼ U,C,R,T,A and L models

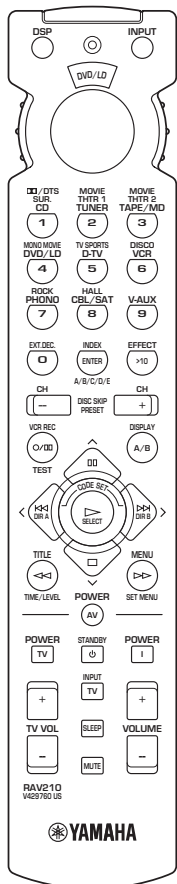

### ▼ B and G models

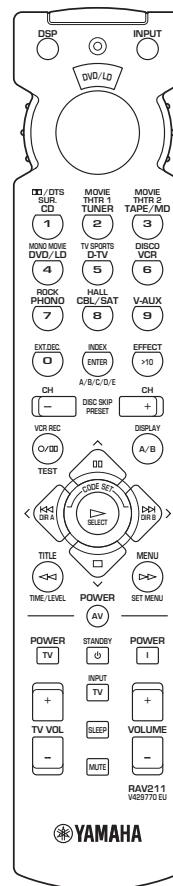

## ■ SPECIFICATIONS

### ■ AUDIO SECTION

#### Minimum RMS Output Power Per Channel (Power Amp. Section)

U, C models		
MAIN L/R, REAR L/R		
20Hz to 20kHz, 0.06% THD, 8Ω		100W+100W
1kHz, 0.09% THD, 8Ω		110W+110W
CENTER		
20Hz to 20kHz, 0.06% THD, 8Ω		100W
1kHz, 0.09% THD, 8Ω		110W
R,T,A,B,G,L models		
MAIN L/R, REAR L/R		
20Hz to 20kHz, 0.06% THD, 8Ω		70W+70W
1kHz, 0.09% THD, 8Ω		80W+80W
CENTER		
20Hz to 20kHz, 0.06% THD, 8Ω		70W
1kHz, 0.09% THD, 8Ω		80W

#### Maximum Power (EIAJ)

R, T models only		
MAIN L/R, REAR L/R		
1kHz, 10% THD, 8Ω		105W+105W
CENTER, 1kHz, 10% THD, 8Ω		
		105W

#### Dynamic Power Per Channel (IHF)

MAIN L/R		
U, C models		
8/6/4/2Ω		130W+130W/150W+150W/190W+190W/240W+240W
R,T models		
8/6/4/2Ω		90W+90W/110W+110W/135W+135W/160W+160W

#### DIN Standard Output Power Per Channel

G model only		
MAIN L/R, REAR L/R		
1kHz, 0.7% THD, 4Ω		110W+110W
CENTER, 1kHz, 0.7% THD, 4Ω		
		110W

#### Dynamic Headroom(8Ω)

U, C models only		1.14dB
------------------	--	--------

#### IEC Power

G model only		
MAIN L/R, 1kHz, 0.06% THD, 8Ω		
		75W+75W

#### Damping Factor (SPEAKER A)

MAIN L/R, 20Hz to 20kHz, 8Ω		80
-----------------------------	--	----

#### Input Sensitivity/Input Impedance

PHONO (MM)		2.5mV/47kΩ
CD etc.		150mV/47kΩ
MAIN L/R (EXTERNAL DECODER)		150mV/47kΩ
CENTER		150mV/40kΩ
SURROUND L/R		150mV/40kΩ
SUB WOOFER		150mV/40kΩ

#### Maximum Input Signal Level (1kHz)

PHONO (MM), 0.1% THD		100mV
CD etc. (EFFECT ON), 0.5% THD		2.2V

#### Output Level/Output Impedance

REC OUT		150mV/1.2kΩ
PRE OUT		2.1V / 1.2kΩ
SUB WOOFER (MAIN SP : SMALL)		4V/1.2kΩ

#### Headphone Jack Rated Output/Impedance

CD etc., Input=1kHz, 150mV, RL=8Ω		0.34V/560Ω
-----------------------------------	--	------------

#### Frequency Response(10Hz to 100kHz)

CD etc., MAIN		0/-3dB
---------------	--	--------

#### RIAA Equalization Deviation

PHONO (MM)		0±0.5dB
------------	--	---------

#### Total Harmonic Distortion(20Hz to 20kHz)

PHONO (MM) to REC OUT (1V)		0.02%
CD etc.(EFFECT OFF) to MAIN SP OUT(35W/8Ω)		0.06%

#### Signal-to-Noise Ratio(IHF-A Network)

PHONO (MM), Input shorted, REC OUT		
U, C, R, T models		86dB
A, B, G, L models		81dB
CD etc.(EFFECT OFF), Input shorted, SP OUT		
		99dB

#### Residual Noise(IHF-A Network)

MAIN L/R, SP OUT		150μV
------------------	--	-------

#### Channel Separation(Vol. -30dB, EFFECT OFF)

PHONO, Input shorted, 1kHz/10kHz		60dB/55dB
CD etc, Input 5.1kΩ terminated, 1kHz/10kHz		60dB/45dB

#### Tone Control Characteristics

BASS : Boost/Cut		±10dB(50Hz)
: Turnover Frequency		350Hz
TREBLE : Boost/Cut		±10dB(20kHz)
: Turnover Frequency		3.5kHz

#### Filter Characteristics

MAIN, REAR SP SMALL : H.P.F.	fc=90Hz, 12dB/oct.
SUB WOOFER : L.P.F.	fc=90Hz, 18dB/oct.

### ■ FM SECTION

#### Tuning Range

U, C models		87.5 to 107.9MHz
R, T models (Frequency Step: 100kHz)		
		87.5 to 108.0MHz
(Frequency Step: 50kHz)		
		87.50 to 108.00MHz
A, B, G, L models		87.50 to 108.00MHz

#### 50dB Quieting Sensitivity (IHF)

U, C, R, T models only		
Mono, 1kHz, 100% mod		1.6μV(15.3dBf)
Stereo, 1kHz, 100% mod		23μV(38.5dBf)

#### Usable Sensitivity (DIN)

A, B, G, L models only		
DIN, Mono(S/N 26dB)		0.9μV
DIN, Stereo(S/N 46dB)		28μV

#### Alternate Channel Selectivity

U, C, R, T models (±400kHz)		75dB
A, B, G, L models (±300kHz)		
Selectivity(two signals, 40kHz Dev.)		55dB

#### Signal-to-Noise Ratio

U, C, R, T models (IHF)		
Mono/Stereo		81dB/75dB
A, B, G, L models (DIN-Weighted, 40kHz Dev.)		
Mono/Stereo		75dB/69dB

#### Harmonic Distortion (1kHz)

Mono/Stereo		0.1%/0.2%
-------------	--	-----------

#### Stereo Separation (1kHz)

		48dB
--	--	------

#### Frequency Response (20Hz to 15kHz)

		0±1dB
--	--	-------

#### Output Level (1kHz)

U, C, R, T models (100% mod.)		550mV
A, B, G, L models (40kHz Dev.)		550mV

#### Antenna Input

		75Ω unbalanced
--	--	----------------

■AM SECTION

<b>Tuning Range</b>	
U, C models	530 to 1710kHz
R, T models (Frequency Step : 10kHz)	530 to 1710kHz
(Frequency Step : 9kHz)	531 to 1611kHz
A, B, G, L models	531 to 1611kHz
<b>Usable Sensitivity</b> 300μV/m	
<b>Signal-to-Noise Ratio</b> 52dB	
<b>Output Level</b> (1kHz, 30% mod.) 150mV	
<b>Antenna</b> Loop antenna	

■VIDEO SECTION

<b>Video Signal Type</b>	
U, C models	NTSC
R model	NTSC/PAL
T, A, B, G, L models	PAL
<b>Video Signal Level</b> 1Vp-p/75Ω	
<b>S-Video Signal Level</b> Y:1Vp-p/75Ω,C:0.286Vp-p/75Ω	
<b>Maximum Input Level</b> 1.5Vp-p	
<b>Signal-to-Noise Ratio</b> 50dB	
<b>Monitor Output Frequency Response</b> (-3dB) 5Hz~10MHz	

■GENERAL

<b>Power Supply</b>	
U, C models	AC120V, 60Hz
R model	AC110/120/220/240V, 50/60Hz
T model	AC220V, 50Hz
A model	AC240V, 50Hz
B, G, L models	AC230V, 50Hz

<b>Power Consumption</b>	
U model	280W
C model	310W/410VA
R, T models	310W
A, B, G, L models	300W

<b>Standby Power Consumption</b>	
U, C, models	0.70W
A, B, G, L models	0.89W

<b>Maximum Power Consumption</b>	
R model only	
5CH Simultaneous output, 10% THD	510W

<b>AC Outlet</b>	
U, C, R, T, G, L models, Switched x 2	100W max(Total)
A, B models, Switched x 1	100W max

<b>Dimensions</b> (W x H x D)	435 x 151 x 390.5mm (17-1/8" x 5-15/16" x 15-3/8")
-------------------------------	---

<b>Weight</b>	11.2kg(24lbs. 11oz)
---------------	---------------------

<b>Accessories</b>	Remote Control Transmitter x 1 AM loop antenna x 1 Indoor FM antenna x 1 Battery (size "AAA", "R03") x 4
--------------------	---

\* Specifications subject to change without notice.

U..... U. S. A. model	A..... Australian model
C..... Canadian model	B..... British model
R..... General model	G..... European model
T..... China model	L..... Singapore model

BL.....Black model	GD.....Gold model
TI.....Titan model	

● DIMENSIONS

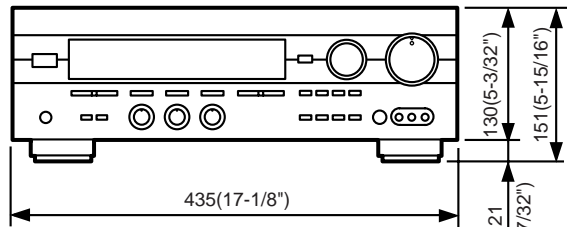
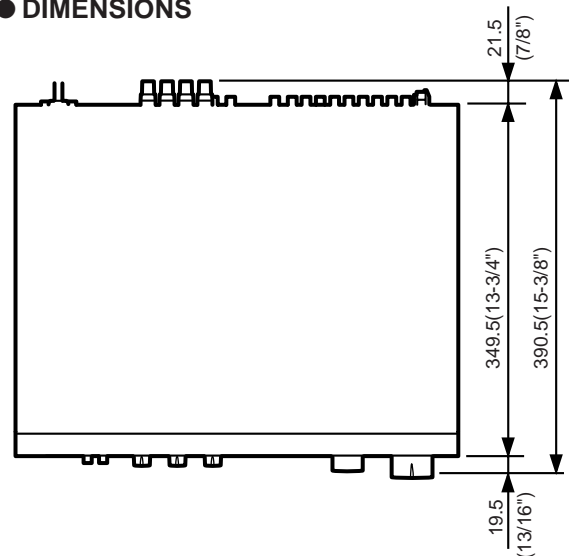

Units: mm (inch)

**WARNING**

Do not change the **IMPEDANCE SELECTOR** switch setting while the power to this unit is on, otherwise this unit may be damaged.

**IMPEDANCE SELECTOR**

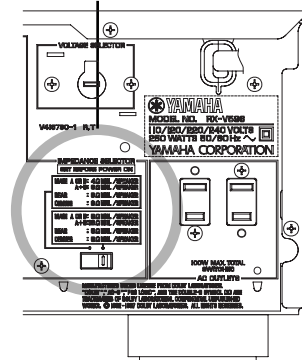

Manufactured under license from Digital Theater Systems, Inc. US Pat. No. 5,451,942 and other worldwide patents issued and pending. "DTS", "DTS Digital Surround", are trademarks of Digital Theater Systems, Inc. Copyright 1996 Digital Theater Systems, inc. All rights reserved.

Manufactured under license from Dolby Laboratories. "DOLBY", "AC-3", "PRO LOGIC", and the double-D symbol  are trademarks of Dolby Laboratories. Confidential unpublished works. ©1992-1997 Dolby Laboratories. All rights reserved.

## INTERNAL VIEW

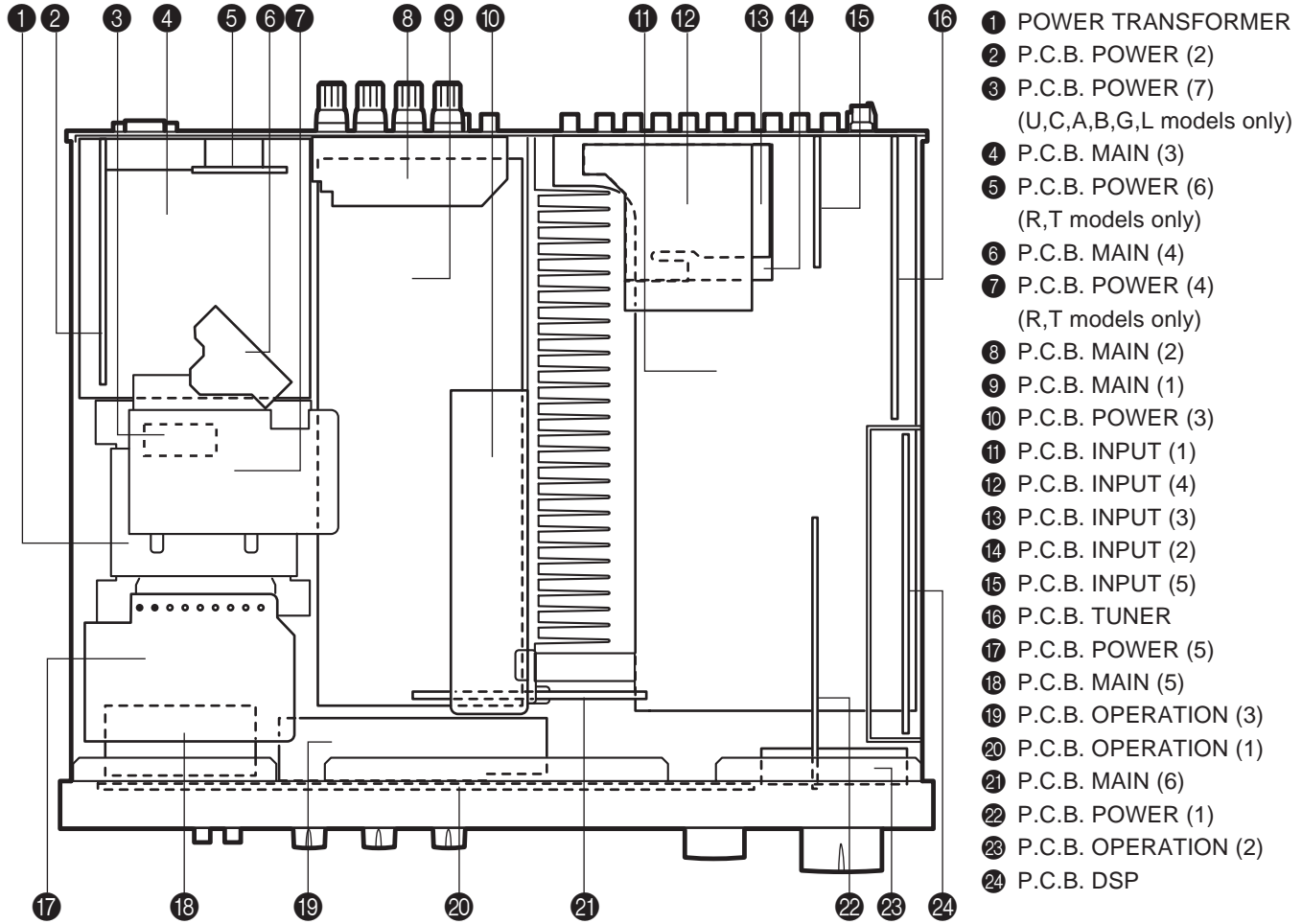

## DISASSEMBLY PROCEDURES

(Remove parts in disassembly order as numbered.)

### 1. Removal of Top Cover

Remove 4 screws (①) and 4 screws (②) in Fig. 1.

### 2. Removal of Front Panel

- a. Remove 5 knobs.
- b. Remove 6 screws (③) in Fig. 1.

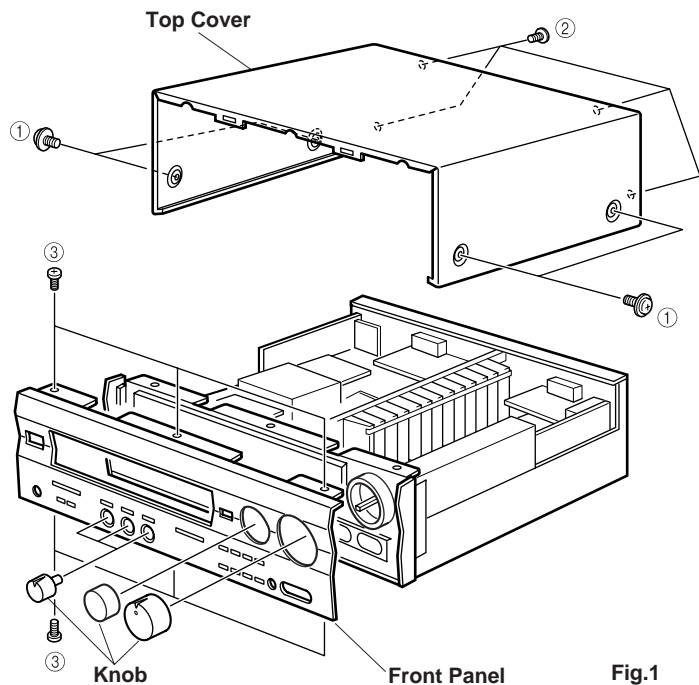

Fig.1

## ■ SELF DIAGNOSIS FUNCTION

### 1. PURPOSE AND OPERATION

The RX-V596/HTR-5250/RX-V596RDS has a Self Diagnosis Function to locate a faulty part, if any, by inspecting and taking measurements.

There are 12 main items in the diagnostic menu and sub-menu items as listed below.

No.	MAIN MENU	SUB-MENU	REMOTE CONTROL CODE (KEY)
1	ANALOG THROUGH	1. MAIN BYPASS 2. DSP 0dB	7A-88 ("1" [DSP mode]) ---
2	DSP THROUGH	1. YSS+SRAM M 2. YSS M 3. DSP FULL BIT	7A-89 ("2" [DSP mode]) --- ---
3	AC-3/DTS THROUGH	1. STATUS (BINARY FORM)	---
4	PRO LOGIC	1. CENTER LARGE 2. EFFECT OFF	7A-8A ("3" [DSP mode]) ---
5	SPEAKERS SET	1. MAIN : SMALL 0dB 2. MAIN : LARGE 0dB 3. MAIN : LARGE -10dB 4. LFE/BASS : MAIN CENTER : NONE 5. LFE/BASS : MAIN 6. LFE/BASS : SUBWOOFER 7. CENTER : NONE 8. CENTER : SMALL REAR : SMALL 9. FRONT MIX	7A-8B ("4" [DSP mode]) 7A-8C ("5" [DSP mode]) 7A-8D ("6" [DSP mode]) 7A-8E ("7" [DSP mode])  7A-8F ("8" [DSP mode]) 7A-90 ("9" [DSP mode]) 7A-91 ("0" [DSP mode]) ---  7A-12 ("ENTER" [DSP mode])
6	DISPLAY CHECK (EFFECT OFF)	1. (EFFECT OFF) 2. ALL SEGMENTS TURN OFF 3. ALL SEGMENTS TURN ON 4. ALTERNATE SEGMENTS TURN ON 5. SOFTWARE RELEASE DATE	7A-56 (">10" [DSP mode]) --- --- --- ---
7	MANUAL TEST	1. ALL 2. MAIN L 3. CENTER 4. MAIN R 5. REAR R 6. REAR L 7. LFE	--- --- --- --- --- --- ---
8	FACTORY PRESET	1. INHIBIT (Inhibit Memory Initialize) 2. RESERVED (Reserve Memory Initialize)	--- ---
9	AD DATA CHECK	1. --- 2. KEY1, KEY2 3. TUNER SIGNAL LEVEL 4. DC PROTECTION 5. PS PROTECTION	--- --- --- --- ---
10	STATUS INFORMATION FROM DSP	1./2. DSP STATUS (1)/(2) 3./4. CHANNEL STATUS (1)/(2) 5./6. BSI0 (1)/(2) 7./8. BSI1 (1)/(2) 9./10. BSI2 (1)/(2) 11./12. BSI3 (1)/(2) 13./14. BSI4 (1)/(2) 15./16. BSI5 (1)/(2)	--- --- --- --- --- --- ---
11	EEPROM WRITING FUNCTION	1. CHECK SUM MODIFICATION DATA EEPROM DATA 2. WRITING CONFIRMATION 3. START WRITING	---  --- ---
12	UNIT INFORMATION/ EXIT	1. VERSION and CHECK SUM 2. MODEL TYPE and DESTINATION 3. EXIT	--- --- ---

## 2. BEGINNING AND CANCELLATION

### (1) Starting up the function and the display

After starting up, main-menu No.1 is selected.

#### A. How to start diagnostic program

Using the front panel keys of the main unit.

Plug in the AC power cord. With the Power OFF, hold down the "PRESET/TUNING ▷" and "A/B/C/D/E" keys simultaneously (Step 1), then press the "STANDBY/ON" key (Step 2).

Sub menu No. 1 of the diagnosis main menu No. 1 will start.

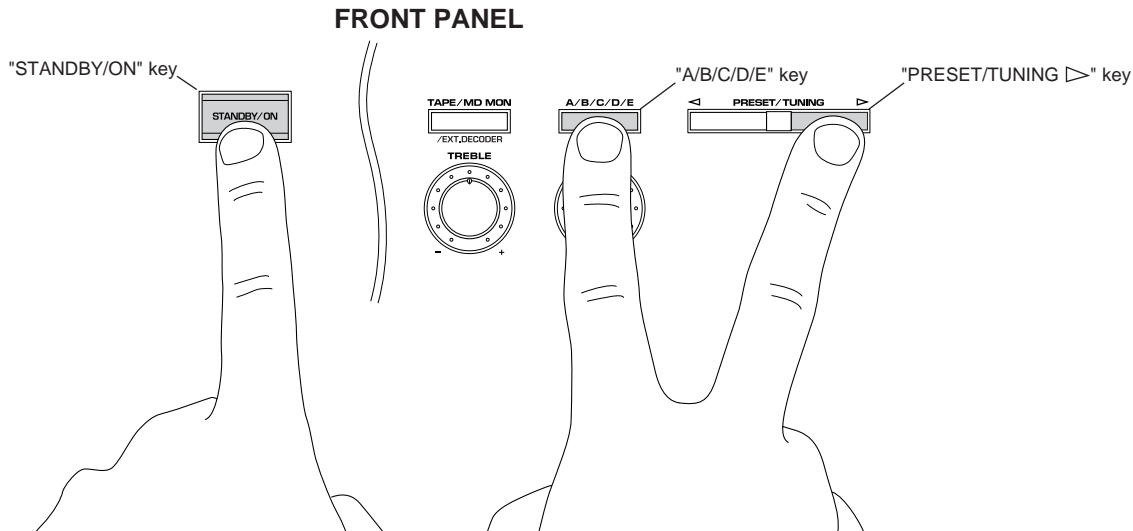

Step2. Press the "STANDBY/ON" key.

Step1. Hold down the "PRESET/TUNING ▷" and "A/B/C/D/E" key simultaneously.

#### B. Settings for start-up of diagnostic program

The settings used when starting the diagnostic program are as follows.

1. EFFECT LEVEL :

CHANNEL	CENTER	R SUR	L SUR	SWFR
LEVEL (dB)	0	0	0	0

- 2. MUTING : OFF
- 3. INPUT (VIDEO) : DVD/LD (DVD/LD)
- 4. CENTER SPEAKER : LARGE
- 5. REAR SPEAKER : LARGE
- 6. MAIN SPEAKER : LARGE
- 7. LFE/BASS OUT : SWFR

#### C. Start-up display

The protection history information appears on the front panel display.

### ● FL display at start-up of diagnostic program

When the diagnostic program has started, the check sum of the main microcomputer or the protection history (\*1) is displayed. If the protection function has been activated in the past, the type and voltage value are displayed. After a few seconds the diagnosis function menu will appear.

(\*1) If a faulty condition is detected such as excessive current, a bad power supply or excessive amplifier DC offset, the Power will be switched OFF automatically.

**Note)** For the voltages of the power and DC protection functions, see the diagnosis main menu No. 9, which will be described later. The protection history will be cleared when "RESERVED" is selected in the diagnosis main menu No. 8 and FACTORY PRESET is engaged.

### ● Protection history

The following examples show how the protection history is displayed:

**CHK SUM : XXXX X**

Appears when the protection function has not been activated. Displayed the check sum (4-digit, hexadecimal) and the version (one letter) of the main microcomputer.

**I PROTECTION**

Appears when the current protection function has been activated. When power is turned on in an abnormal condition, the power relay will come on, protection will operate immediately, and power will turn off.

**PS PRT : XX%**

Appears when the power supply protection function has been activated. For the % value, the voltage at that point is shown by 5V/100%. When power is turned on in an abnormal condition, power will turn off after half a second.

**DC PRT : XX%**

Appears when the power amp DC protection function has been activated. For the % value, the voltage at that point is shown by 5V/100%. When power is turned on in an abnormal condition, power will turn off after two seconds.

## (2) Exiting method

The diagnosis function can be exited by any of the following procedures. Take care with the setting of backup memory initialization menu (diagnosis No. 8) when releasing the diagnosis function.

1. Select sub-menu No. 3 "EXIT" of the diagnosis main menu No. 12.
2. Press the "STANDBY/ON" key on the main unit or "STANDBY" key on the remote control to turn Power OFF.



### 3. OPERATION AND DISPLAY WHEN STARTING DIAGNOSIS FUNCTION

#### (1) Selection of diagnostic menu

The diagnostic menu and the sub-menu can be selected by using the front panel keys of the main unit or the remote control unit.

##### ● Selection by using the front panel keys of the main unit

The main menu can be changed cyclically by using the "PROGRAM </>" keys, and the sub-menu, by using the "PRESET/TUNING </>" keys. The ">" key will increase the main or sub-menu number.

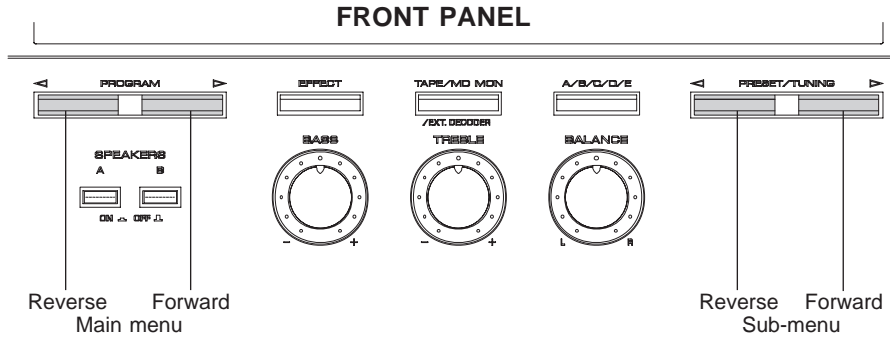

##### ● Selection by using the remote control unit

The remote control codes in the menu list (see right column on page 8) correspond to the DSP program, test and effect keys. See the figure on the right.

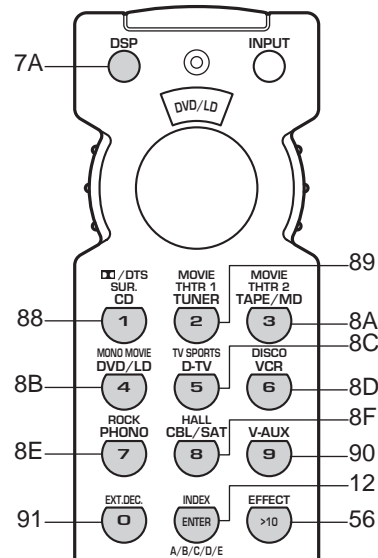

#### (2) Other functions available while diagnosis function is active

Listed below are the other functions available while the diagnosis function is active.

- Selection of the input (include TAPE MONITOR/EXTERNAL DECODER)
- Effect level control (CENTER, REAR, SUBWOOFER)
- Master volume control
- Muting on/off
- Power on/off

#### (3) Diagnosis default status

When not otherwise specified, default settings and values in each menu are as follows:

- SPEAKERS : All "LARGE"
- Electronic Volumes : All "0dB"
- DYNAMIC RANGE : MAX
- LFE LEVEL : 0dB (-10dB in AC-3(DOLBY DIGITAL))
- CENTER DELAY : 0ms

## 4. CONTENTS OF DIAGNOSIS FUNCTION

This section describes the contents of the Self Diagnosis Function in detail.

### No.1 ANALOG THROUGH

The input is fixed to analog (A/D). There are two sub-menus.

#### 1. MAIN BYPASS **1 MAIN BYPASS**

The L/R signals bypass the digital circuit, and are output to the MAIN L/R.

The L/R signals are output without being processed to the CENTER/SUBWOOFER, FRONT L/R and REAR L/R through the DSP. (Remote control code 7A-88: "1" key [DSP mode])

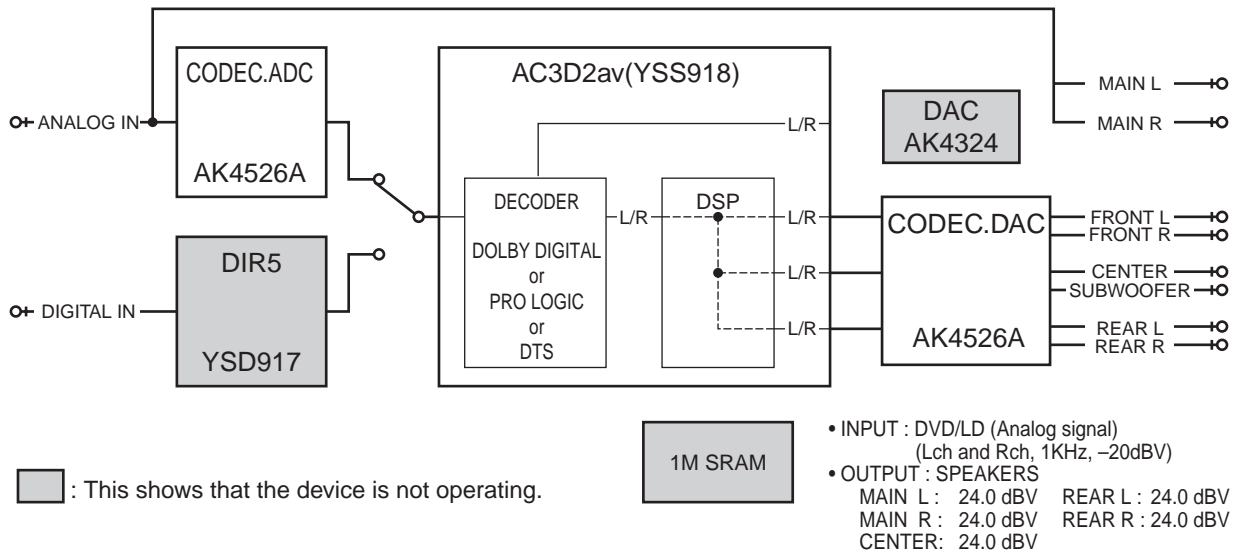

#### 2. DSP 0dB **1 DSP 0dB**

The L/R signals are output without being processed to the MAIN L/R through the AC3D2av.

The L/R signals are output without being processed to the CENTER/SUBWOOFER, FRONT L/R and REAR L/R through the DSP.

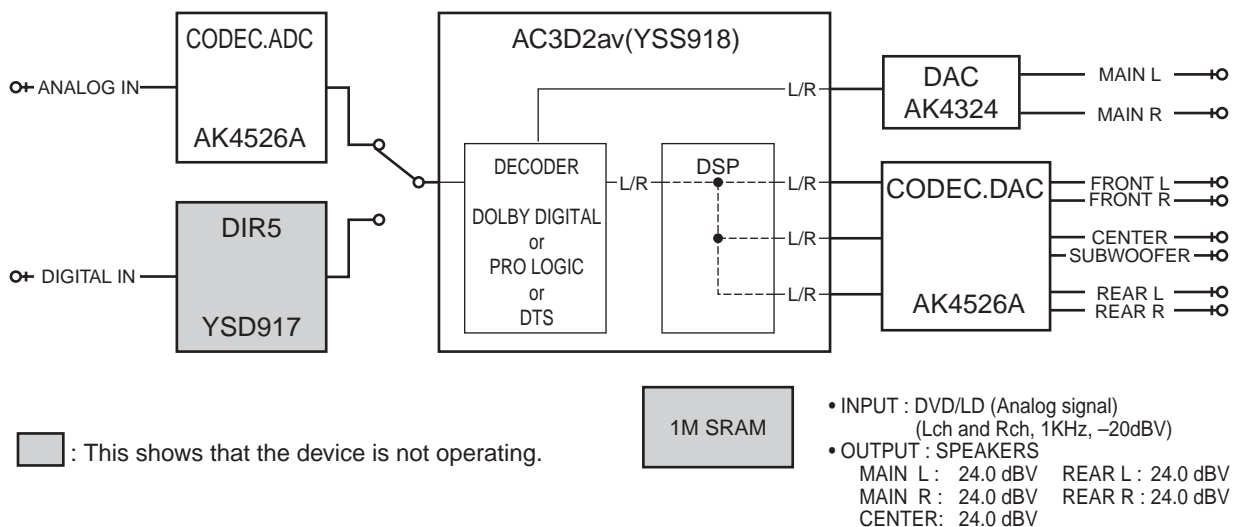

**No.2 DSP THROUGH**

The input is automatically discriminated by signal detection and switched with priorities Coaxial>Optical>Analog.  
There are the following three sub-menus.

**1. YSS+SRAM** **2 YSS+SRAM M**

The L/R signals are output without being processed to the MAIN L/R through the AC3D2av.  
The L/R signals are output without being processed to the CENTER/SUBWOOFER through the DSP.  
The (L+R)/2 signals are output to the FRONT L/R and REAR L/R through the DSP and the SRAM.  
When one of the L/R signals is not input, the output level is -6dB. (Remote control code 7A-89:"2" key [DSP mode])

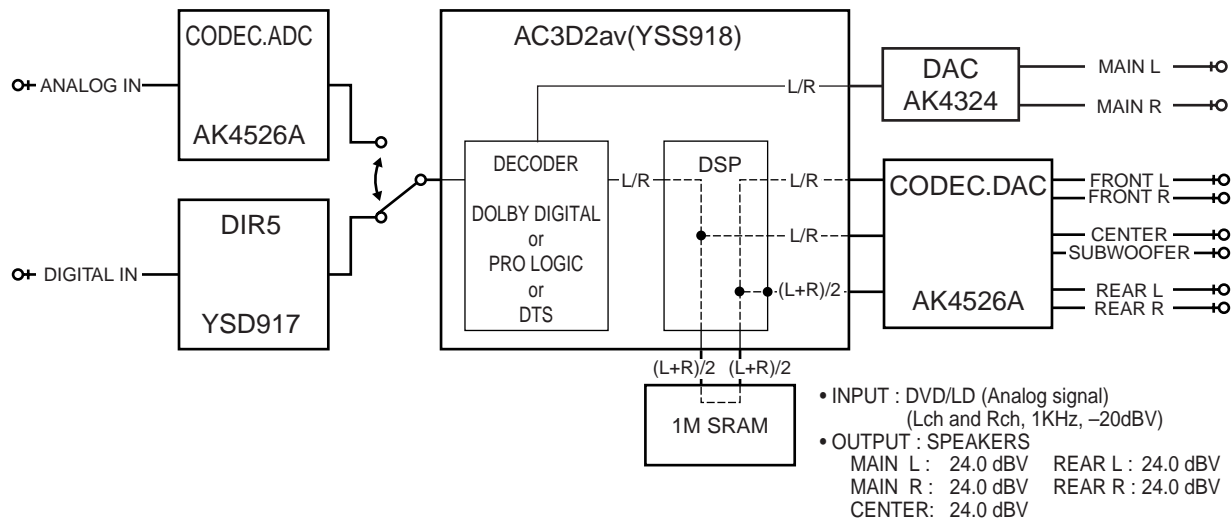

**2. YSS M** **2 YSS M**

Same as "2. DSP 0dB" of "No.1 ANALOG THROUGH", except for the input switching.

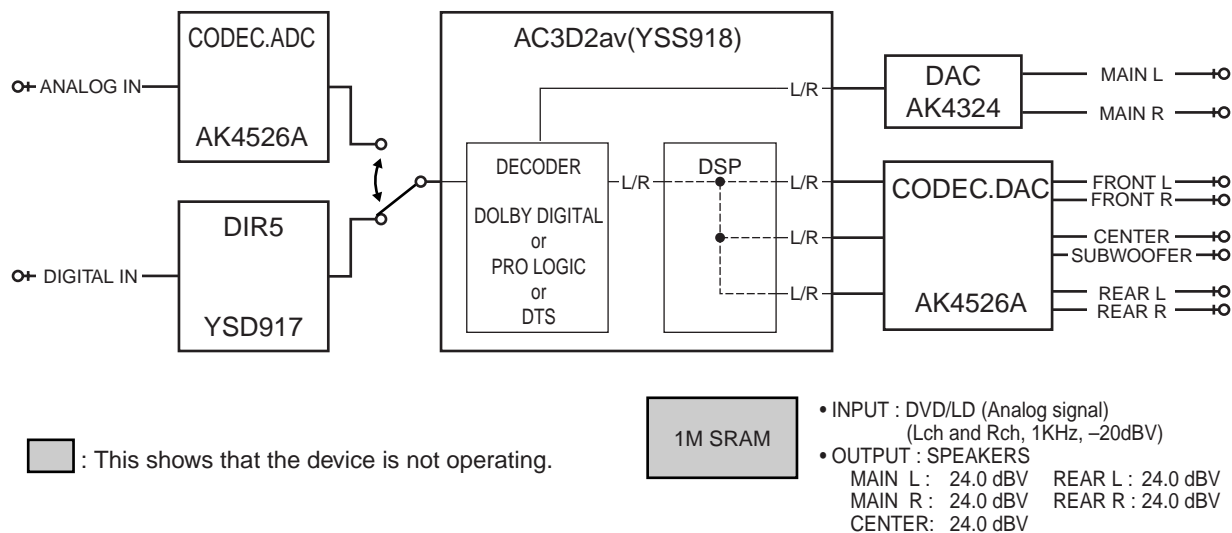

**3. DSP FULL BIT** **2 DSP FULL BIT**

Same as the above menu, except that the head margin is disabled, and the digital data is output with full bits from AC3D2av to DAC.

- INPUT : DVD/LD (Analog signal)  
(Lch and Rch, 1KHz, -30dBV)
- OUTPUT : SPEAKERS  
MAIN L : 14.0 dBV REAR L : 23.3 dBV  
MAIN R : 14.0 dBV REAR R : 23.3 dBV  
CENTER: 17.2 dBV

### No.3 AC-3/DTS THROUGH

The input is digital signal only. AC-3 (DOLBY DIGITAL) or DTS Digital Surround decoding operation is executed, according to the input source.

#### 1. STATUS(BINARY FORM)

bit 7                      bit 1  
3 ST: 10001001

AC-3 (DOLBY DIGITAL) decoded signals are output to each channel via AC3D2av.  
 The AC-3 (DOLBY DIGITAL) signal status data will be displayed in the FL display using a binary number.

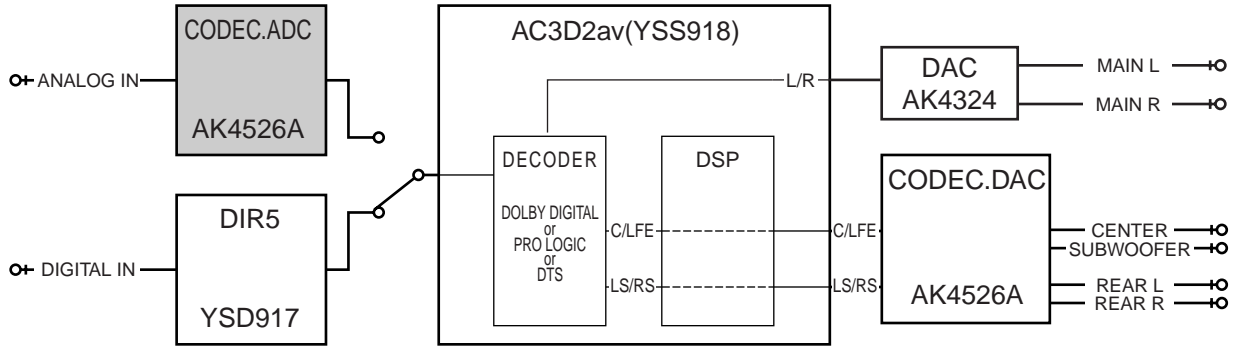

: This shows that the device is not operating.

1M SRAM

AC-3 Status Info. : bit 7 6 5 4 3 2 1 0  
 (Invalid in DTS) 1 0 0 0 1 0 0 1

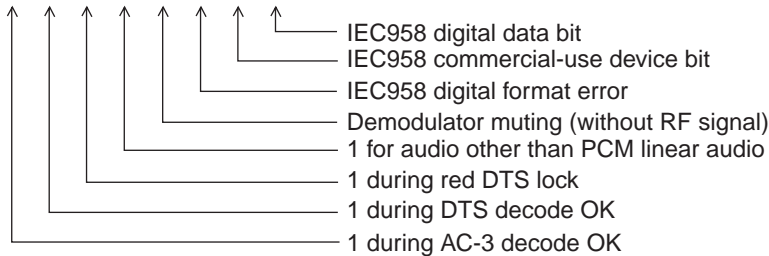

### No.4 PRO LOGIC

The submenu is switched between PRO LOGIC (AUTO BALANCE OFF) and EFFECT OFF.

#### 1. CENTER LARGE 4 PRO CNTR: LRG

The input is automatically discriminated by signal detection and switched with priorities Coaxial>Optical>Analog. DTS Digital Surround is disabled. The input signals are PRO LOGIC decoded and output.  
 (Remote control code 7A-8A: "3" key [DSP mode])

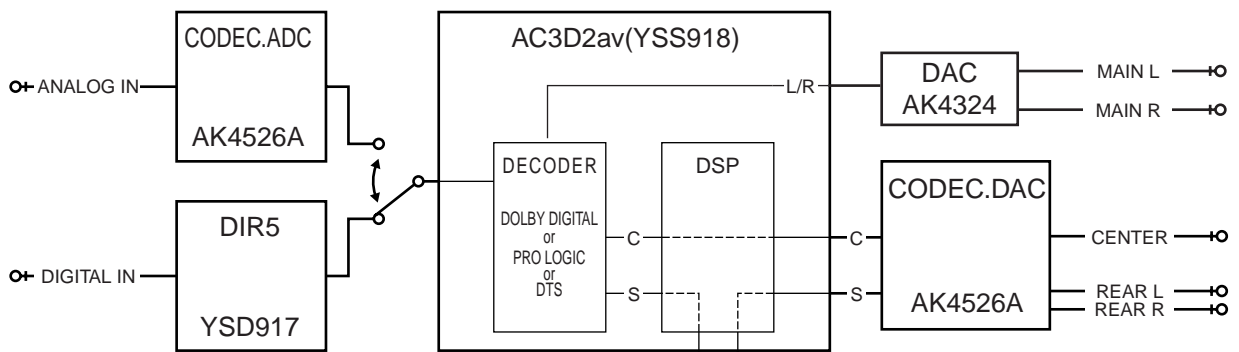

- INPUT : DVD/LD (Analog signal)  
 (Lch and Rch, or Lch only, 1kHz, -20dBV)
- OUTPUT : SPEAKERS  
 (INPUT : Lch and Rch) (INPUT : Lch only)
- MAIN L : -12.5 dBV      MAIN L : 24.0 dBV
- MAIN R : -12.5 dBV      MAIN R : -19.0 dBV
- CENTER: 27.0 dBV      CENTER : -10.0 dBV
- REAR L : -9.0 dBV      REAR L : -9.0 dBV
- REAR R : -9.0 dBV      REAR R : -9.0 dBV

#### 2. EFFECT OFF 4 PRO EFCT: OFF

The input is only for analog signal. The L/R signals bypass the digital circuit and are output to the MAIN L/R.

**No.5 SPEAKERS SET**

The input is automatically discriminated by signal detection and switched with priorities Coaxial>Optical>Analog.  
 The L/R signals are output to channels specified by the sub-menu without being processed.  
 There are the following nine sub-menus items. Signal routes of the sub-menu 1-4 are the same as EFFECT OFF.  
 But MAIN L/R are signals through the digital circuit.  
 Signal routes of the sub-menu 5-9 are the same as "2. YSS M" of "No. 2 DSP THROUGH".  
 However, only MAIN L/R are output in the sub-menu 1-4.

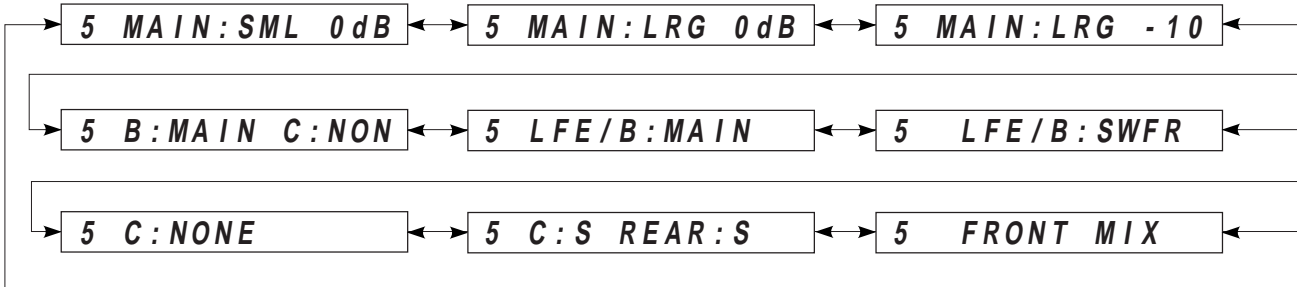

The analog switches in each sub-menu are set as follows:

	SUB MENU	REMOTE CONTROL CODE	SETTING					OUTPUT					
			CENTER SP	REAR SP	MAIN SP	MAIN LEVEL	LFE/BASS	MAIN L	MAIN R	CENTER	REAR L	REAR R	SUB WOOFER
1	MAIN:SML 0DB	7A-8B	LARGE	LARGE	SMALL	0dB	SWFR	L	R	NONE	NONE	NONE	L+R
2	MAIN:LRG 0DB	7A-8C	LARGE	LARGE	LARGE	0dB	SWFR	L	L	NONE	NONR	NONE	NONE
3	MAIN:LRG -10	7A-8D	LARGE	LARGE	LARGE	-10dB	SWFR	L	L	NONE	NONE	NONE	NONE
4	B:MAIN C:NONE	7A-8E	NONE	LARGE	LARGE	0dB	MAIN	L	L	NONE	NONE	NONE	NONE
5	LFE/B:MAIN	7A-8F	LARGE	LARGE	LARGE	0dB	MAIN	LFE+FL	LFE+FR	NONE	NONE	NONE	NONE
6	LFE/B:SWFR	7A-90	LARGE	LARGE	LARGE	0dB	SWFR	NONE	NONE	NONE	NONE	NONE	LFE
7	C:NONE	7A-91	NONE	LARGE	LARGE	0dB	SWFR	C+L	C+R	NONE	NONE	NONE	NONE
8	C:S REAR:S	---	SMALL	SMALL	LARGE	0dB	SWFR	FL	FR	C	RL	RR	C+RL+RR+LFE
9	FRONT MIX	7A-12	LARGE	LARGE	LARGE	0dB	SWFR	FL	FR	NONE	NONE	NONE	NONE

**LARGE:** Mode in which speakers with high bass-sound playback capability (large unit) are used. Full-range signals present on the channel are output from the speaker.  
**SMALL:** Mode in which speakers with low bass-sound playback capability (small unit) are used. Low bass signals (below 90Hz) on the channel are mixed into the channel selected by the LFE/BASS setting.  
**NONE:** Mode in which center speaker is not used. The center channel signal is reduced by 3 dB and mixed into MAIN L/R.  
**LFE/B:MAIN**  
 : Mode in which subwoofer speaker is not used. The LFE channel signal is reduced by 4.5 dB and mixed into MAIN L/R. But because of the phase difference, the MAIN L/R output is not simply summed.

Description of the submenu as follows:

	SUB MENU	DESCRIPTION
1	MAIN:SML 0DB	Verification of the High and low pass filter response and gain in the bass redirection mode.
2	MAIN:LRG 0DB	Reference of the sub menu No. 1 and 3.
3	MAIN:LRG -10	Verification of the effect in the main level function.
4	B:MAIN C:NONE	Verification of the mixing circuit effect to the main channel.
5	LFE/B:MAIN	Verification of the bass mix gain.
6	LFE/B:SWFR	Verification of the LFE maximum output.
7	C:NONE	Verification of the center mix gain.
8	C:S REAR:S	Verification of the high and low pass filter response and gain in the bass redirection mode.
9	FRONT MIX	Verification of the front mix gain.

**No.6 DISPLAY CHECK**

Check program for FL display. The display status will change as follows with sub-menu operation. signal route is the same as "2. EFFECT OFF" of "No. 4 PRO LOGIC".

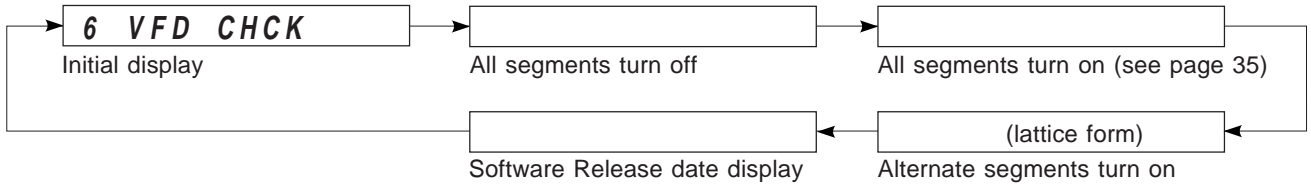

A defect of the FL drive port and FL display segments can be detected by using "All segments turn off" and "All segments turn on".

A short-circuit between adjacent segments can be detected by using "Alternate segments turn on" (lattice form).

**No.7 MANUAL TEST**

By using the noise generator built into the DSP, a test noise outputs to the channel specified by the sub-menu.

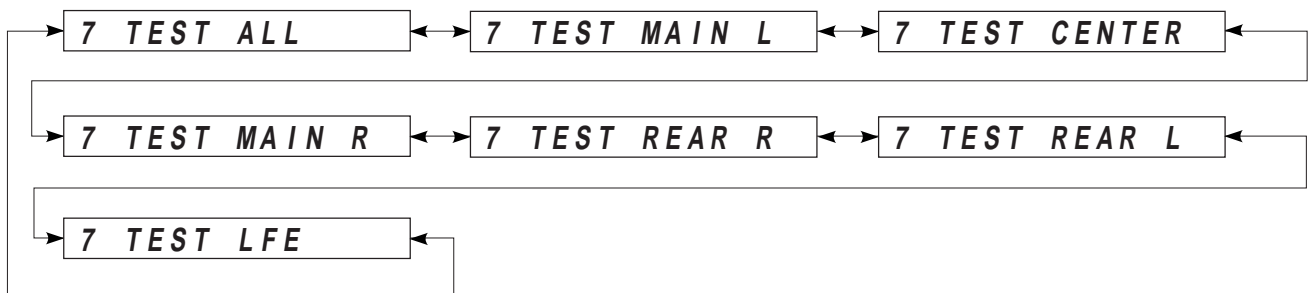

**No.8 FACTORY PRESET**

The initialization of the back-up RAM, which contains, the DSP program, set menu contents, etc. is reserved or inhibited. Signal route is the same as "2. EFFECT OFF" of "No.4 PRO LOGIC".

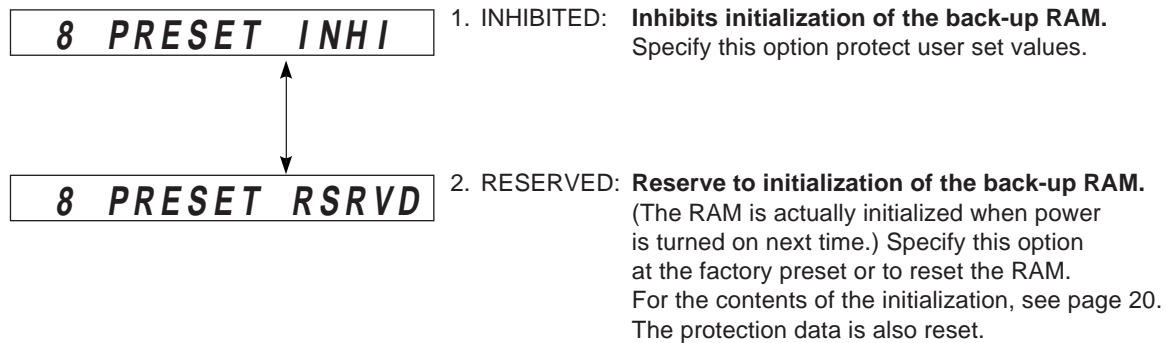

**Caution :** Before setting to the PRESET RESERVED, write down the existing preset memory contents of the Tuner in a table as shown below. (This is because setting to the PRESET RESERVED will cause the memory contents to be as factory set, i.e., all the preset memory by the user will be erased.)

Page	P1	P2	P3	P4	P5	P6	P7	P8
A								
B								
C								
D								
E								

**No.9 AD DATA CHECK**

The A/D conversion values of the microcomputer which detects key scan port, protection detection port, etc. are displayed in % (100%:5V). Signal route is the same as "2. EFFECT OFF" of "No. 4 PRO LOGIC".

The keys on the main unit cannot be operated to detect the values of all keys in the K1/K2 and SI.

Operating the "PROGRAM ◀, ▶" key and turning the rotary encoder ("INPUT SELECTOR" on the main unit) will switch the sub-menu.

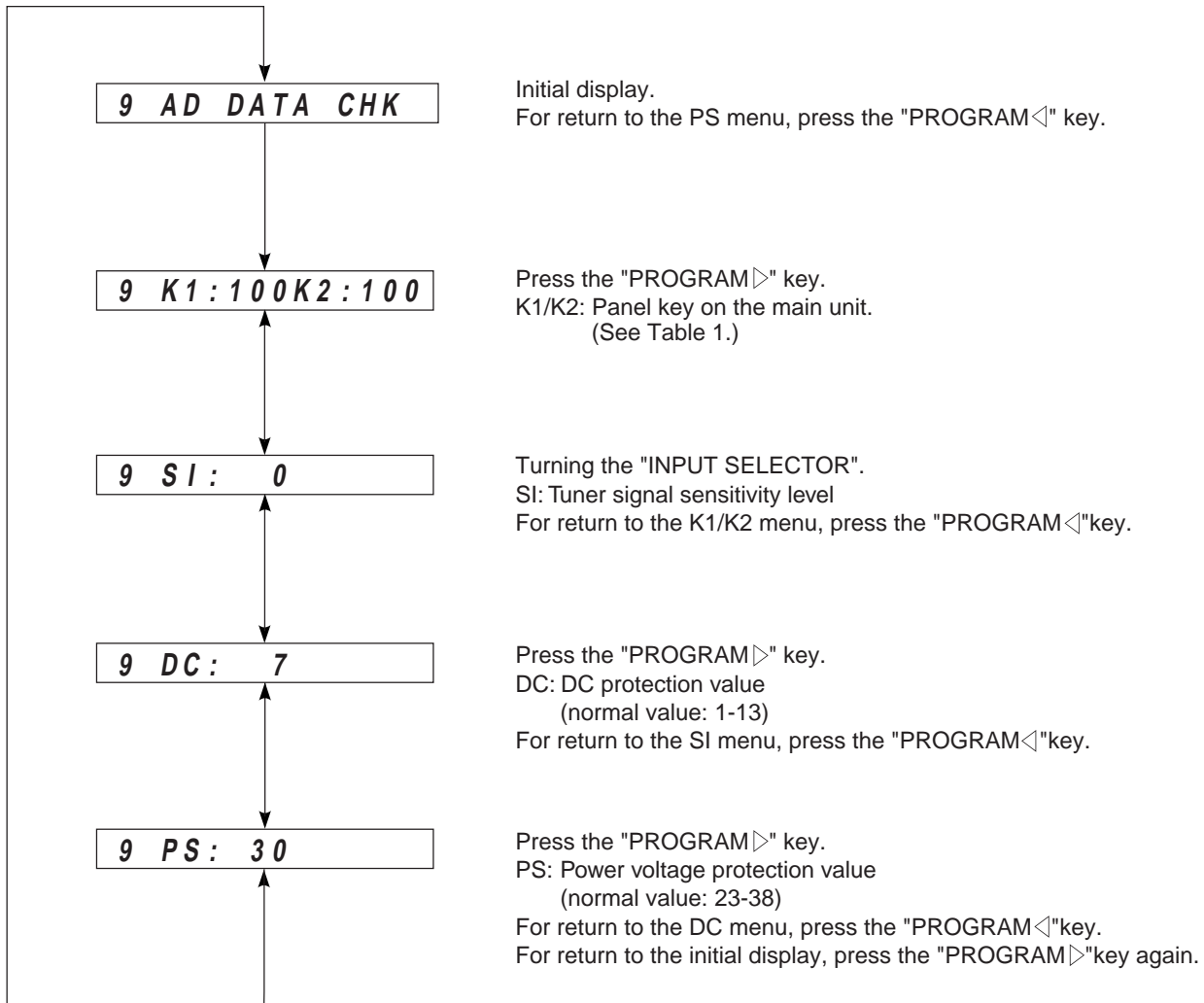

Table 1

AD Value	0	15	25	35	45	55	65	75	85
K1	PROGRAM		EFFECT	TAPE/MD MON /EXT DECODER	A/B/C/D/E	RDS MODE /FREQ	EON	PTY SEEK	
	◀	▶						MODE	START
K2	PRESET/TUNING		INPUT MODE	PRESET /TUNING EDIT	FM/AM	MEMORY MAN'L/AUTO FM	TUNING MODE AUTO/MAN'L MONO	_____	_____
	◀	▶							

**Cautions:**

1. If K1 and K2 are more than ±4% from the reference values, normal operation will not be executed.
2. If DC and PS are outside the normal values, the protection function will operate and power will turn off.

**No.10 STATUS INFORMATION FROM DSP**

The status data from the DSP block is sequentially displayed in a hexadecimal number.  
Signal route is the same as "2. EFFECT OFF" of "No. 4 PRO LOGIC".

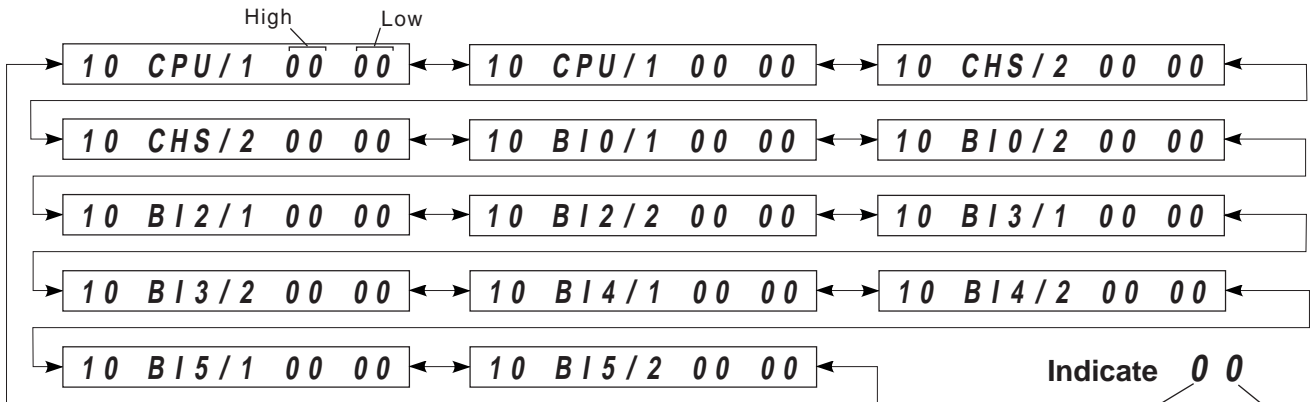

[CPU/1]

<High Byte>

<b>bit7</b>	Mute request	<b>bit3</b>	acmod
<b>bit6</b>	fs	<b>bit2</b>	0000B:1+1      0001B:1/0
<b>bit5</b>	000B:Analog    001B:32kHz	<b>bit1</b>	0010B:2/0      0011B:3/0
<b>bit4</b>	010B:44.1kHz   011B:48kHz	<b>bit0</b>	0100B:2/1      0101B:3/1
	100B:64kHz    101B:88.2kHz		0110B:2/2      0111B:3/2
	110B:96kHz    111B:undefined		1000B:7.1

[Note]

When acmod is beyond 1000B, it is DTS 7.1 signal. And the DSP block will be muted.  
The acmod of DTS 2/0 is as 0000B:1+1.

<Low Byte>

<b>bit7</b>	AC-3 DECODE OK	<b>bit3</b>	DEM (Demodulator) MUTE (without RF signal)
<b>bit6</b>	DTS DECODE OK	<b>bit2</b>	IEC958 digital format error
<b>bit5</b>	Red DTS record (Flashes and lights)	<b>bit1</b>	IEC958 commercial-use device bit
<b>bit4</b>	1 for audio other than PCM linear audio	<b>bit0</b>	IEC958 digital data bit

[Note]

IEC958: Standard to identify the PCM bit stream signal. Digital format error refers to a digital signal with the sampling frequency undefined (neither 32k,44.1k,48k,64k,88.2k nor 96k). Since the operation of each device cannot be assured at fs outside specifications, this status handled as the forced analog mode (ignored even if decoding is OK from the detection terminal level), and the signals from the analog input terminal will be selected. Bits 4-6 of "CPU/1" will be 000B (Analog), and the microcomputer operates in the same way as with digital unlocking.

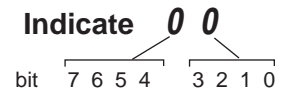

Indicate	bit			
	3	2	1	0
0	0	0	0	0
1	0	0	0	1
2	0	0	1	0
3	0	0	1	1
4	0	1	0	0
5	0	1	0	1
6	0	1	1	0
7	0	1	1	1
8	1	0	0	0
9	1	0	0	1
A	1	0	1	0
B	1	0	1	1
C	1	1	0	0
D	1	1	0	1
E	1	1	1	0
F	1	1	1	1

[CPU/2]

<High Byte>

<b>bit7</b>	AC3 KARAOKE	<b>bit3</b>	1
<b>bit6</b>	DIR2 LOCKN	<b>bit2</b>	0
<b>bit5</b>	DIR2 ERR	<b>bit1</b>	DSP is AC3D2 (DTS present)
<b>bit4</b>	AC3D MUTE	<b>bit0</b>	RF DEM (Demodulator) present

<Low Byte> Always "00"

[CHS/1,/2] IEC958 channel status bits 00-31 available from DIR5.

- <CHS/1 High Byte>      bits 00-07
- <CHS/1 Low Byte>      bits 08-15
- <CHS/2 High Byte>      bits 16-23
- <CHS/2 Low Byte>      bits 24-31

[BIO/1,/2] Displays the bit stream information contained in AC-3(DOLBY DIGITAL)/DTS Digital Surround signal from the first byte.

[BI1-5/1,/2] Displays the bit stream information contained in AC-3(DOLBY DIGITAL) signal from the first byte.



**No.11 EEPROM WRITING FUNCTION**

The check sum value confirmation of EEPROM and data writing.  
Signal route is the same as "2. EFFECT OFF" of "No. 4 PRO LOGIC".

**M:XXXX E:XXXX**

M:XXXX: The check sum value is displayed when the microcomputer has ROM modification data.  
0000 is displayed when there is no data.  
E:XXXX: The check sum value is displayed when the EEPROM is installed on and it has the ROM data .  
000 is displayed when EEPROM is not mounted on or data is unusual.  
If you want to write ROM modification data of the microcomputer into the EEPROM, change to the next sub-menu.

**No.12 UNIT INFORMATION/EXIT**

The version of the microcomputer and the check sum, the model type and the destination are displayed.  
Signal route is the same as "2. EFFECT OFF" of "No.4 PRO LOGIC".  
By the sub-menu operation, the set exits the self-diagnosis mode and returns to the normal operation mode.

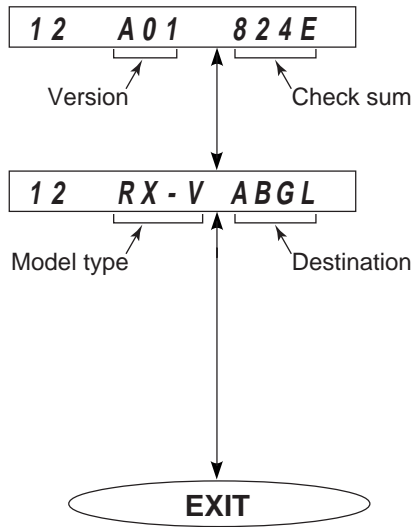

The version and the check sum of the microcomputer software are displayed.  
A01: Microcomputer software version.  
824E: Microcomputer software check sum.

The model type and the destination are displayed.  
RX-V: Model type.  
DSP-A= DSP-A5  
RX-V = RX-V596, HTR-5250  
RDS = RX-V596RDS  
ABGL: Destination.  
J = J model  
UC = U and C models  
ABGL = A,B,G and L models  
R = R and T model

## ■ FACTORY PRESET

All of the system settings are initially set from the factory as follows.

### ● INPUT SELECTOR

INPUT		FACTORY PRESET PROGRAM
ROTARY ENCODER	PHONO	CONCERT HALL
	CD	DISCO
	TUNER	ROCK CONCERT
	DVD/LD	SCI-FI
	D-TV	TV SPORTS
	VCR	DOLBY NORMAL
	V-AUX	DOLBY ENHANCED
	CBL/SAT	ROCK CONCERT
MONITOR	TAPE/MD	EFFECT OFF
EXTERNAL	EXT. DECODER	NONE

### ● EFFECT LEVEL

EFFECT CHANNEL	PRESET VALUE
CENTER	0 dB
RIGHT SURROUND	0 dB
LEFT SURROUND	0 dB
SUBWOOFER	0 dB

### ● DSP PROGRAM

No.	PROGRAM	SUB-PROGRAM	DELAY PRESET VALUE
1.	DOLBY/DTS SURROUND	NORMAL	PRO LOGIC : 20ms,
		ENHANCED	DOLBY DIGITAL/DTS DIGITAL SUR : 5ms
2.	MOVIE THEATER 1	SPECTACLE	70mm : 23ms, DGTL/DTS : 15ms
		SCI-FI	70mm : 20ms, DGTL/DTS : 16ms
3.	MOVIE THEATER 2	ADVENTURE	70mm : 20ms, DGTL/DTS : 15ms
		GENERAL	
4.	MONO MOVIE	-	49ms
5.	TV SPORTS	-	9ms
6.	DISCO	-	40ms
7.	ROCK CONCERT	-	16ms
8.	CONCERT HALL	-	44ms

### ● SET MENU

No.	SET MENU	PRESET VALUE
1.	CENTER SP SIZE	CENTER SP : LRG(LARGE)
2.	REAR SP SIZE	REAR SP : LARGE
3.	MAIN SP SIZE	MAIN SP : LARGE
4.	BASS OUT MODE	BASS OUT : BOTH
5.	M. LVL CHOICE	MAIN LVL : NRML (NORMAL)
6.	D. D. LFE OUT LEVEL	D. D. LFE 0 dB
7.	D. RNG CHOICE	D-RANGE : MAX
8.	DTS LFE OUT LEVEL	DTS LFE 0 dB
9.	C. DELAY CHANGE	CENTER DELAY 0ms
10.	MEMORY GUARD	MEM. GUARD : OFF
11.	INPUT MODE D-TV	TV INPUT : AUTO
12.	INPUT MODE CBL/SAT	CBL INPUT : AUTO

### ● PRESET STATIONS

STATION		FM FACTORY PRESET DATA (MHz)		STATION		AM FACTORY PRESET DATA (kHz)	
PAGE	NO.	U, C	R, T, A, B, G, L	PAGE	NO.	U, C, R	R, T, A, B, G, L
A/C/E	1	87.5	87.5	B/D	1	630	630
	2	90.1	90.1		2	1080	1080
	3	95.1	95.1		3	1440	1440
	4	98.1	98.1		4	530	531
	5	107.9	108.0		5	1710	1611
	6	88.1	88.1		6	900	900
	7	106.1	106.1		7	1350	1350
	8	107.9	108.0		8	1400	1404

## AMP ADJUSTMENT

### Confirmation of Idling Current of Main Amplifier

- Right after power is turned on, confirm that the voltage across the terminals of R688(Main Lch),R690(Main Rch), R692(Center), R694(Rear Lch), R696(Rear Rch) are between 0.1mV and 10.0mV.
- If it exceeds 10.0mV, open (cut off) R571 (Main Lch), R577 (Main Rch), R583 (Center), R589 (Rear Lch), R595 (Rear Rch) and reconfirm the voltage.
- Confirm that the voltage is 0.20mV ~ 15.0mV after 60 minutes.

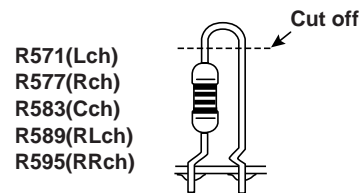
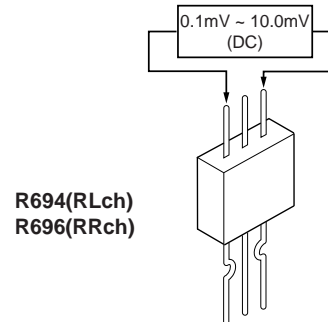
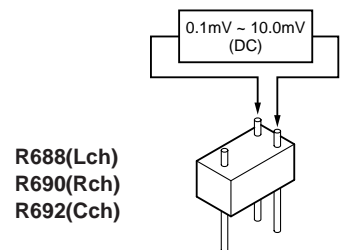
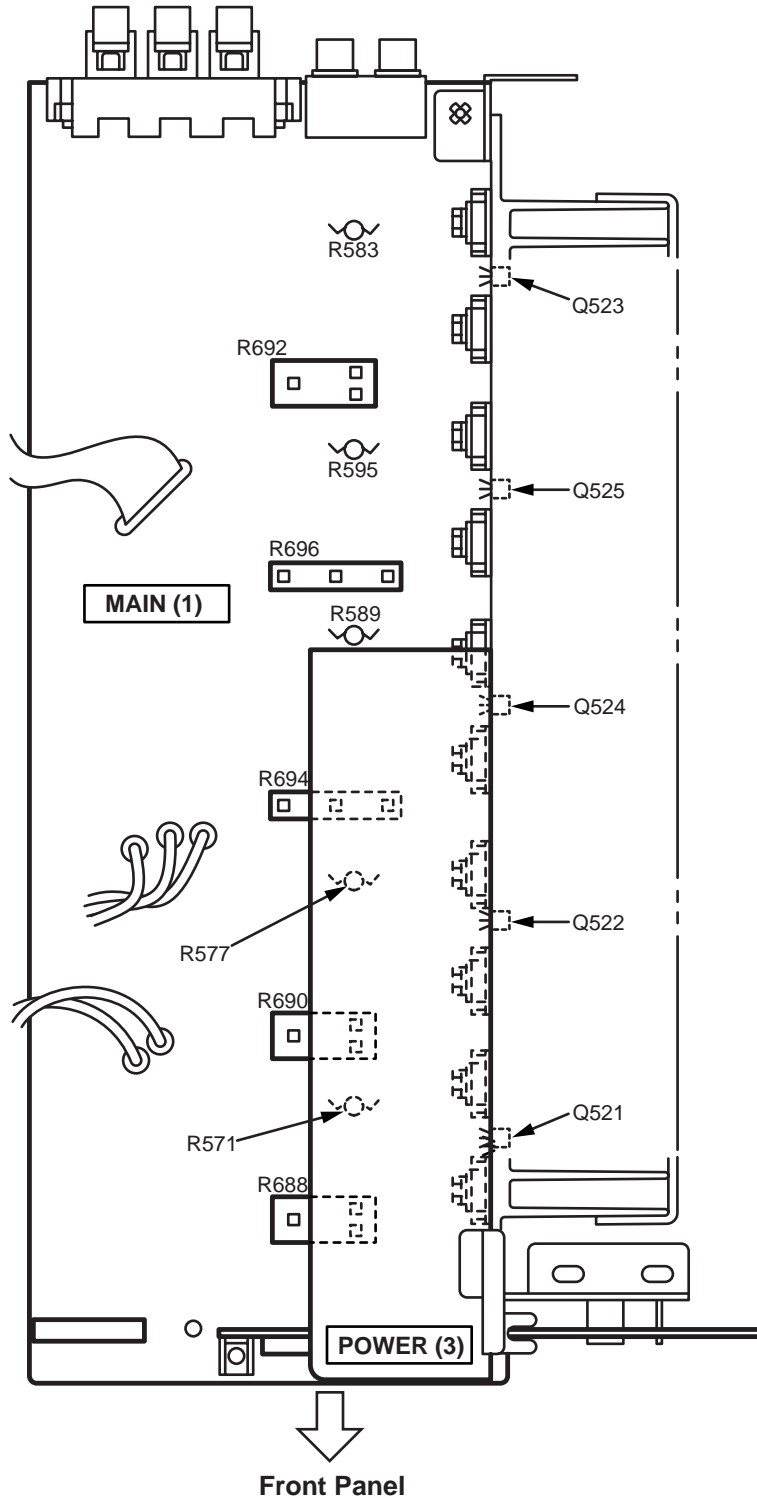

**Note)**

- If R571, R577, R583, R589 and R595 have already been cut off and idling current does not flow, reconnect R571, R577, R583, R589 and R595.
- Q521 ~ Q525 are transistors for temperature correction. Apply silicone grease to contact surface with the heat sink.

# ■ TUNER ADJUSTMENT

## ● Measuring Instruments

- 1) FM signal generator (FM SG)
- 2) Stereo signal generator (SSG)
- 3) AM signal generator (AM SG)
- 4) Distortion meter (DIST. M)
- 5) AC Voltmeter (ACVM)
- 6) DC Voltmeter (DCVM)
- 7) Oscilloscope
- 8) Low pass filter (YLF-15,  $f_c=15\text{kHz}$ )
- 9) Oscillator

## ● Dummy antenna

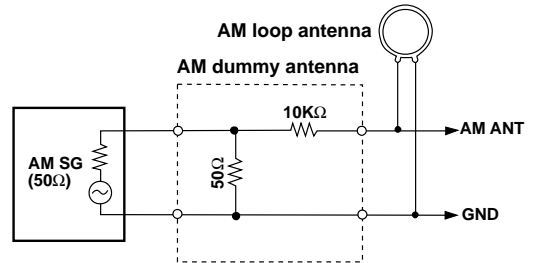
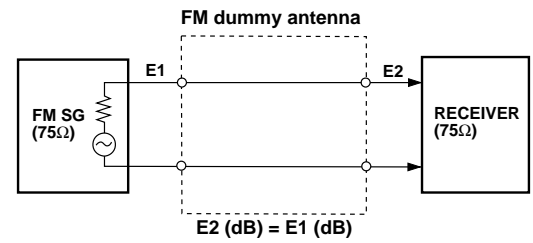
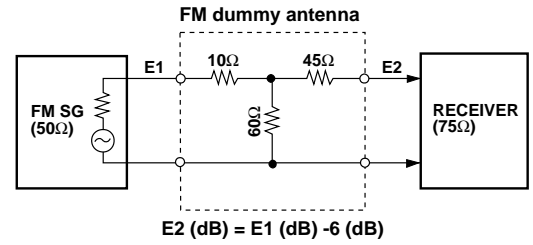

## ● Test point

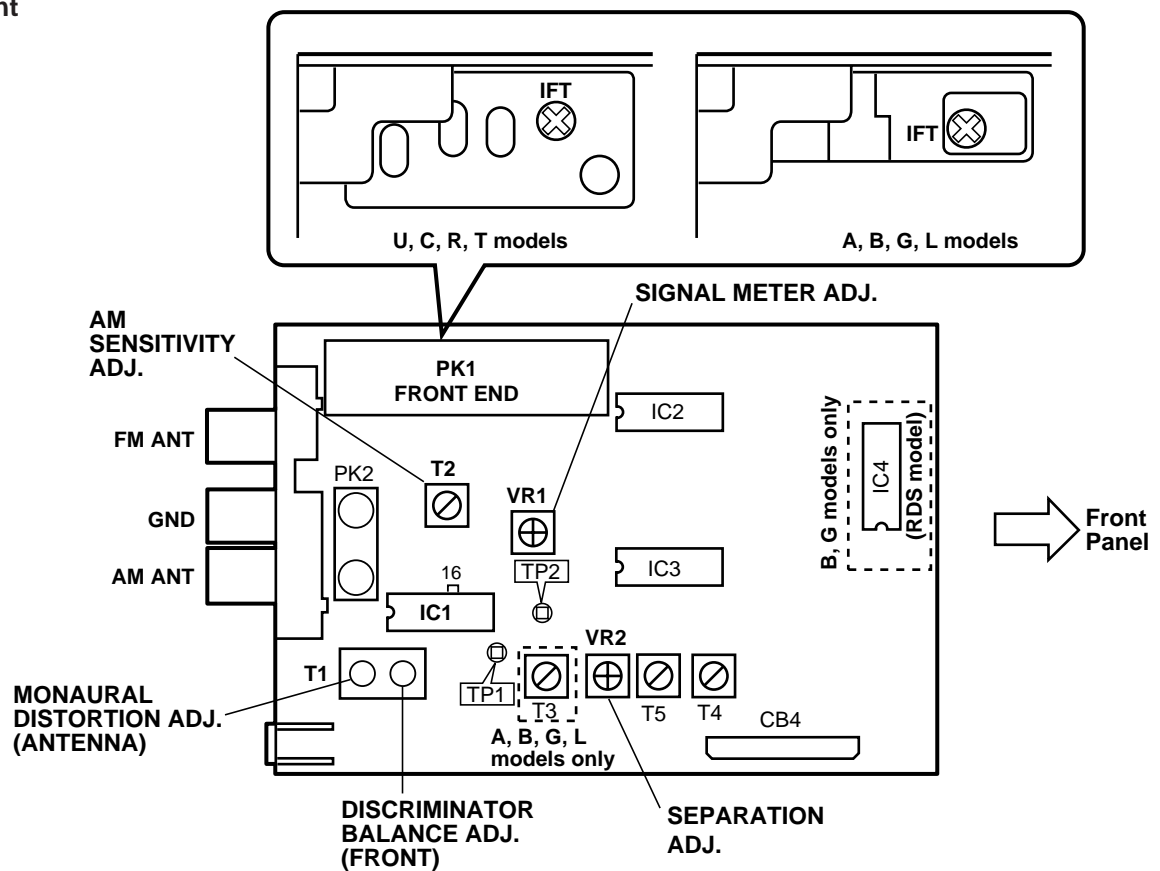

## FM Adjustment

### ● Before Adjustment

- 1) For dB $\mu$ , 1 $\mu$ V=0dB $\mu$  applies.  
**Example** : 60dB $\mu$ =1mV
- 2) 100% modulation means that the frequency deviation is  $\pm$ 75kHz.
- 3) Install the Matching Transformer and connect FM SG.

- 4) Set each switch to the following position unless otherwise specified.

**INPUT SELECTOR ..... TUNER**  
**TUNING MODE ..... AUTO**

### ● Connection diagram (Measuring instruments)

- 1) Discriminator balance adjustment.

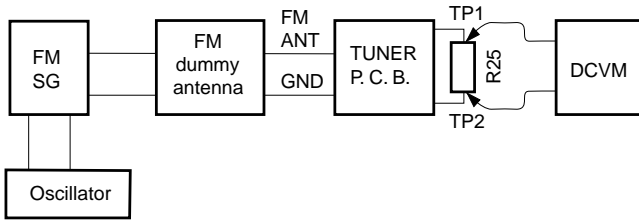

- 2) Stereo distortion adjustment/separation adjustment.

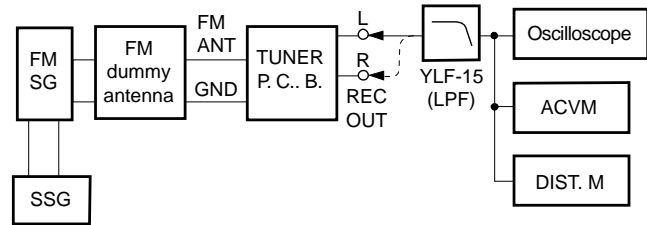

- 3) Monaural distortion adjustment

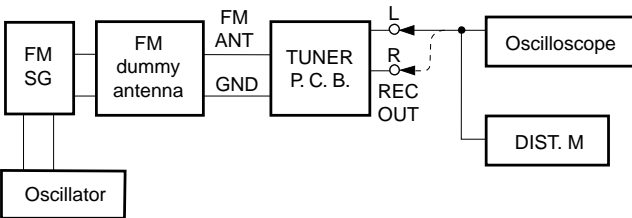

- 4) Sensitivity Verification

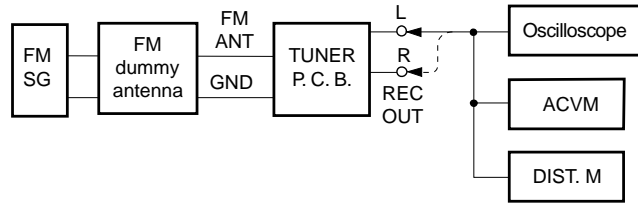

See page 22 for TP locations & adjustment points.

Step	Adjustment item	Signal (ANT IN)	Reception frequency	Adjustment point	Test point	Rating
1	Rough adjustment of discriminator balance	FM ANT (75 $\Omega$ ) 98.1MHz 70dB $\mu$ MONO 100Hz 100% modulation	98.1MHz *(A-4)	T1 (Front side core)	Both ends of R25 (Between TP1 and TP2)	DC 0V $\pm$ 100mV
2	Rough adjustment of monaural distortion	Same as Step 1.	98.1MHz *(A-4)	T1 (Antenna side core)	REC OUT L, R	Minimize the distortion.
3	Fine adjustment of discriminator balance	Same as Step 1.	98.1MHz *(A-4)	T1 (Front side core)	Both ends of R25 (Between TP1 and TP2)	DC 0V $\pm$ 50mV
4	Fine adjustment of monaural distortion	Same as Step 1.	98.1MHz *(A-4)	T1 (Antenna side core)	REC OUT L, R	Minimize the distortion (-60dB or less).
5	Verification of discriminator balance	Same as Step 1.	98.1MHz *(A-4)	T1 (Front side core)	Both ends of R25 (Between TP1 and TP2)	DC 0V $\pm$ 50mV

\* Execution of FACTORY PRESET (Refer to page 20) will facilitate setting reception frequency for adjustment.

See page 22 for TP locations & adjustment points.

Step	Adjustment item	Signal (ANT IN)	Reception frequency	Adjustment point	Test point	Rating
6	Adjustment of front end IFT	FM ANT (75Ω) 98.1MHz 30dBμ MONO 1kHz 100% modulation	98.1MHz *(A-4)	Front end IFT	Pin 16 of IC1	Adjust so that the meter is maximum. <b>CAUTION:</b> Over-adjustment of the IFT core will reduce the sensitivity. (Maximum±90°)
7	Verification of monaural distortion	FM ANT (75Ω) 98.1MHz 70dBμ MONO 1kHz 100% modulation	98.1MHz *(A-4)		REC OUT L, R	0.1% (-60dB or less)
8	Verification of stereo distortion	FM ANT (75Ω) 98.1MHz 70dBμ Stereo L or R 1kHz, 100% modulation	98.1MHz *(A-4) *Tuning mode should be AUTO.		REC OUT L, R	0.2% (U,C,R,T: -54dB or less) (A,B,G,L: -28dB or less) ● STEREO indicator should light.
9	Verification of sensitivity	FM ANT (75Ω) 88.1MHz 98.1MHz 106.1MHz MONO 1kHz Modulation off	88.1MHz *(A-6) 98.1MHz *(A-4) 106.1MHz *(A-7)		ANT (75Ω)	1) Set the tuning mode to MAN'L MONO. 2) S/N should be 30dB at each frequency of 88.1MHz, 98.1MHz, and 106.1MHz. 3) Check to ensure that the voltage at the ANT terminal is as follows. (U,C,R,T: 6dBμ or less) (A,B,G,L : 8dBμ or less)
10	Adjustment of separation	FM ANT (75Ω) 98.1MHz 70dBμ Stereo L or R 1kHz, 100% modulation	98.1MHz *(A-4)	VR2	REC OUT L, R	With SSG output at L or R, the signal leakage level at the other channel should be minimized. (48 dB or less)
11	Adjustment of signal meter	FM ANT (75Ω) 98.1MHz 45dBμ MONO 1kHz, 30% modulation -10dBμ or less	98.1MHz *(A-4)	VR1		Adjust so that all signal meters light.  Check to ensure that signal meters turn OFF.
12	Verification of auto tuning	FM ANT (75Ω) 98.1MHz 23dBμ Stereo L or R 1kHz, 30% modulation	98.1MHz *(A-4)			● Automatic reception should be available when the tuning key is moved UP and DOWN. ● The stereo indicator should light. ● Audio muting should be applied during tuning.

\* Execution of FACTORY PRESET (Refer to page 20.) will facilitate setting reception frequency for adjustment.

**AM Adjustment (This should be done after FM adjustment.)**

● **Connection diagram (Measuring instruments)**

1) Adjustment of sensitivity.

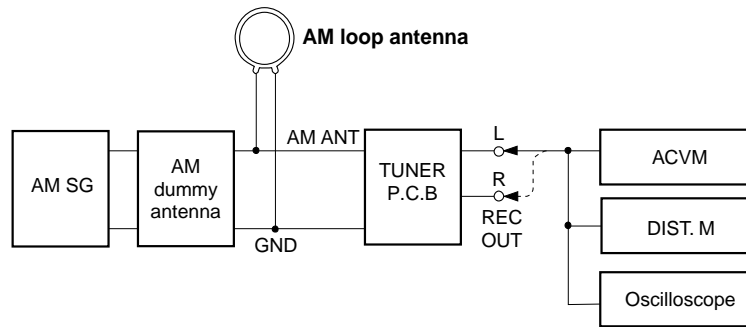

See page 22 for TP locations & adjustment points.

Step	Adjustment item	Signal (ANT IN)	Reception frequency	Adjustment point	Test point	Rating
1	Adjustment of sensitivity (630kHz)	AM ANT 630kHz 50dB $\mu$ 1kHz 30% modulation	630kHz *(B-1)	T2	REC OUT	Audio output should be maximized. Repeat steps 1 and 2.
2	Verification of sensitivity	AM ANT 630kHz 1080kHz 1440kHz 30% modulation	630kHz *(B-1) 1080kHz *(B-2) 1440kHz *(B-3)		AM ANT	Distortion should be 10% or less at each frequency. Check to ensure that the voltage at the ANT terminal is 54dB $\mu$ or less.
3	Verification of signal meter	AM ANT 1080kHz 90dB $\mu$ MONO 1 kHz 30% modulation	1080kHz *(B-2)			All signal meters should light.  All signal meters should turn OFF.
4	Verification of auto tuning	AM ANT 60dB $\mu$				Auto reception should be available when the tuning key is moved UP and DOWN. Audio must be muted during search.

\* Execution of FACTORY PRESET (Refer to page 20.) will facilitate setting reception frequency for adjustment.

# IC DATA

IC501 : M30217MA-A203FP

16-bit Microcomputer

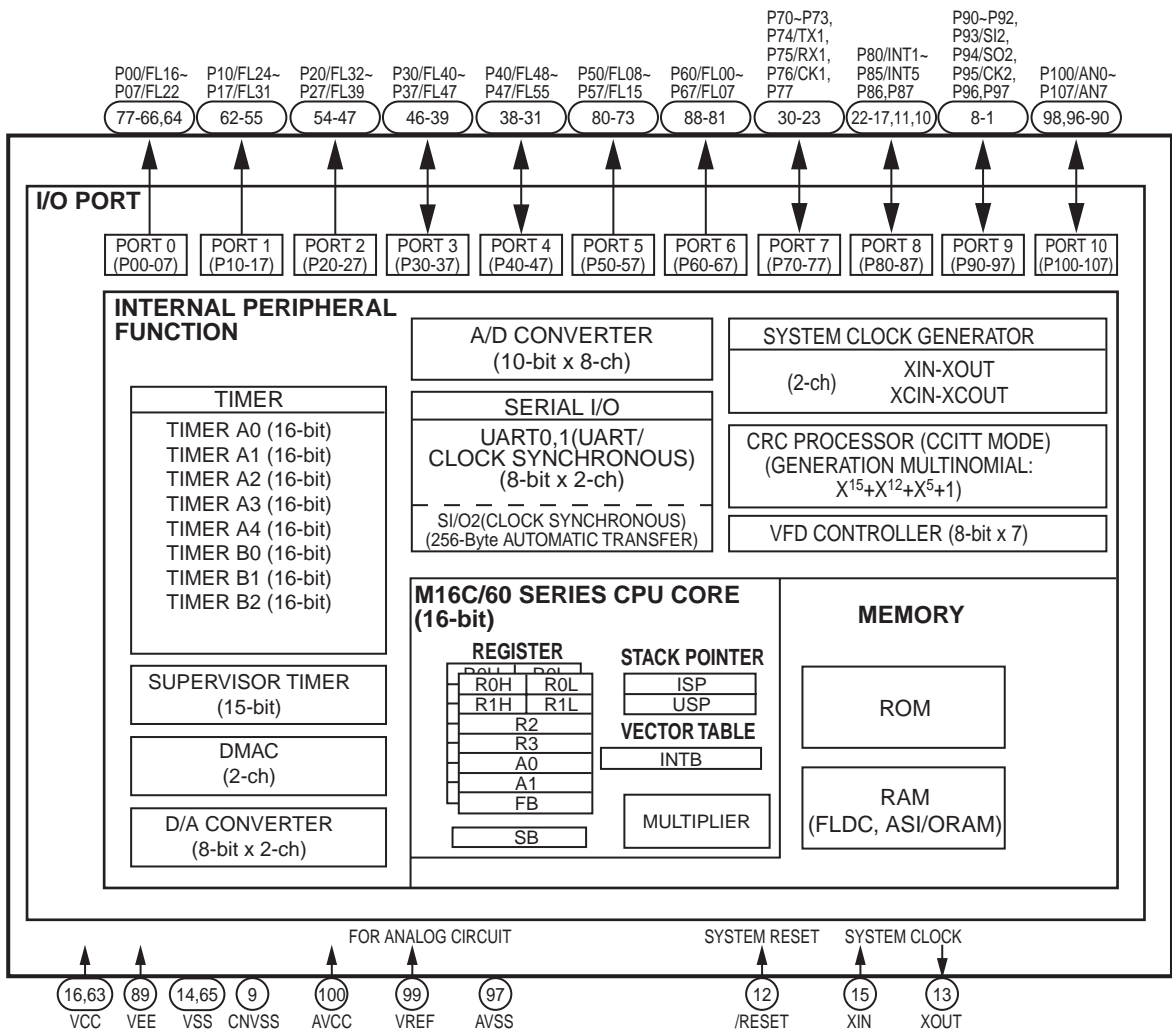
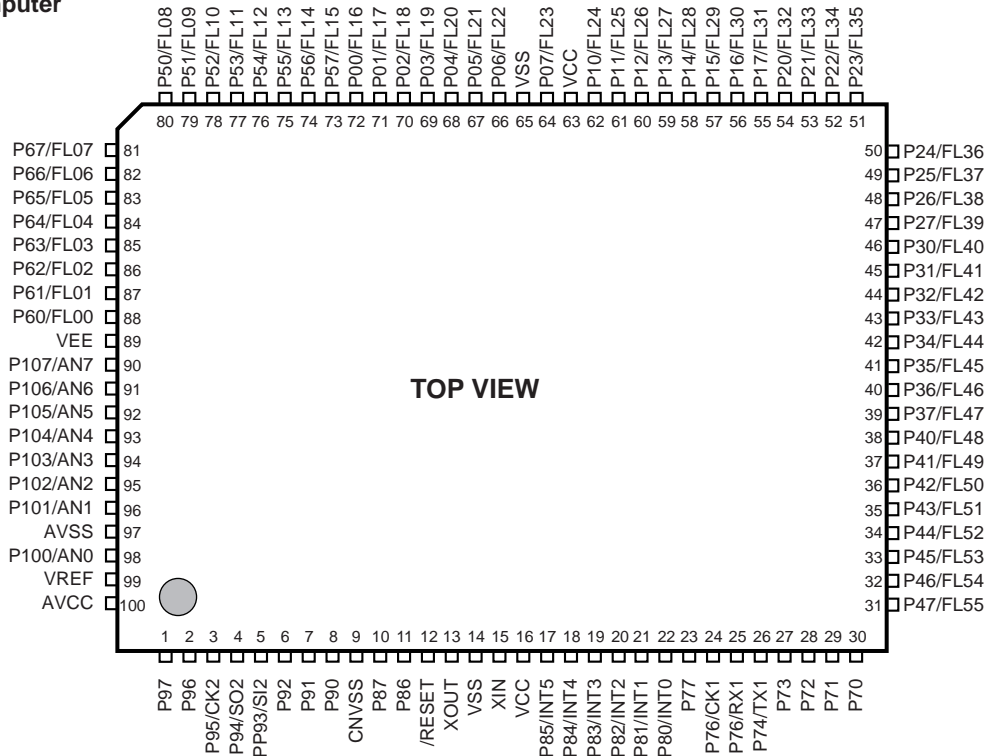



IC501 : M30217MA-A203FP

16-bit Microcomputer

Pin No.	Port	Pin Name	I/O	Function
1	P97	SCK	O	Serial Clock output
2	P96	SDT	O	Serial Data output
3	P95	RCK	O	Clock output for model type distinction (*1)
4	P94	RDT	O	Data output for destination distinction of Tuner (*2)
5	P93	DEST	O	Data input for destination distinction of Tuner (*2)
6	P92	RCE	O	Chip enable output for model type distinction (*1)
7	P91	SCKD	O	Serial Clock output for DIR5
8	P90	SID	O	Serial data output for DIR5
9	CNVSS	CNVSS		For flash μ-COM write connector
10	P87	CKB	O	Clock output for output port expansion IC
11	P86	DTB	O	Data output for output port expansion IC
12	/RESET	/RES		System reset
13	XOUT	XOUT		Crystal oscillator connected (10MHz)
14	VSS	MG		Ground
15	XIN	MU		Crystal oscillator connected (10MHz)
16	VCC	+5BU		+5V Power supply
17	P85/INT5	INTD	I	Interrupt factor detect input from DIR5
18	P84/INT4	ERRA	I	Data mute detect input from AC3D2av
19	P83/INT3	REM	I	Remote control input
20	P82/INT2	PDT	I	Power down detect input
21	P81/INT1	PSW	I	Standby switch input
22	P80/INT0	DBL	I	Double speed sampling mode selection data input DIR5
23	P77	CEAC2	O	Chip enable output 2 for AC3D2av
24	P76/CK1	CLKAC	O	Serial clock output for AC3D2av
25	P75/RX1	RXAC	I	Serial data input from AV3D2av
26	P74/TX1	TXAC	O	Serial data output for AC3D2av
27	P73	CEAC1	O	Chip enable output 1 for AC3D2av
28	P72	TCE	O	Chip enable output for Tuner
29	P71	CELC	O	Chip enable output for Input Selector
30	P70	CETC	O	Chip enable output for Input Selector

Pin No.	Port	Pin Name	I/O	Function
31	P47/FL55	F-CE	O	Chip enable output
32	P46/FL54	F-CK	O	Serial clock output
33	P45/FL53	F-RX	I	Serial data input
34	P44/FL52	F-TX	O	Serial data output
35	P43/FL51	VUP	O	Volume up output
36	P42/FL50	VDN	O	Volume down output
37	P41/FL49	SOD	I	Serial data input from DIR5
38	P40/FL48	CECOD	O	Chip enable output for CODEC
39	P37/FL47	/CSD	O	Chip select output for DIR5
40	P36/FL46	PRI	I	I (Over current) protection detect input
41	P35/FL45	POT-A	I	Rotary encoder input A
42	P34/FL44	POT-B	I	Rotary encoder input B
43	P33/FL43	/ST	I	Stereo input from Tuner
44	P32/FL42	DO	I	Serial data input from Tuner
45	P31/FL41	/ICD	O	Initial clear output for DIR5
46	P30/FL40	PRY	O	Power relay output
47	P27/FL39	SRY	O	Speaker relay output
48	P26/FL38	ERY	O	Effect relay output
49	P25/FL37	G1	O	Grid 1 for FL display
50	P24/FL36	G2	O	Grid 2 for FL display
51	P23/FL35	G3	O	Grid 3 for FL display
52	P22/FL34	G4	O	Grid 4 for FL display
53	P21/FL33	G5	O	Grid 5 for FL display
54	P20/FL32	G6	O	Grid 6 for FL display
55	P17/FL31	G7	O	Grid 7 for FL display
56	P16/FL30	G8	O	Grid 8 for FL display
57	P15/FL29	G9	O	Grid 9 for FL display
58	P14/FL28	G10	O	Grid 10 for FL display
59	P13/FL27	G11	O	Grid 11 for FL display
60	P12/FL26	G12	O	Grid 12 for FL display
61	P11/FL25	G13	O	Grid 13 for FL display
62	P10/FL24	G14	O	Grid 14 for FL display
63	VCC	+5VBU		+5V power supply
64	P07/FL23	G15	O	Grid 15 for FL display
65	VSS	MG		Ground
66	P06/FL22	G16	O	Grid 16 for FL display

\*1 Model type distinction (H=1, L=0)

DSP-A (Pin 3)	0	DSP-A5	0	DSP-E	1	RX-V596	1	RX-V596RDS
RDS (Pin 6)	0		1		0	HTR-5250	1	

\*2 Destination distinction of Tuner (H=1, L=0)

V1 (Pin 4)	0	J model	0	U,C models	1	A,B,G,L models	1	R,T models
V2 (Pin 5)	0		1		0	1		

**IC501 : M30217MA-A203FP**

**16-bit Microcomputer**

Pin No.	Port	Pin Name	I/O	Function
67	P05/FL21	P1	O	Segment 1 for FL display
68	P04/FL20	P2	O	Segment 2 for FL display
69	P03/FL19	P3	O	Segment 3 for FL display
70	P02/FL18	P4	O	Segment 4 for FL display
71	P01/FL17	P5	O	Segment 5 for FL display
72	P00/FL16	P6	O	Segment 6 for FL display
73	P57/FL15	P7	O	Segment 7 for FL display
74	P56/FL14	P8	O	Segment 8 for FL display
75	P55/FL13	P9	O	Segment 9 for FL display
76	P54/FL12	P10	O	Segment 10 for FL display
77	P53/FL11	P11	O	Segment 11 for FL display
78	P52/FL10	P12	O	Segment 12 for FL display
79	P51/FL09	P13	O	Segment 13 for FL display
80	P50/FL08	P14	O	Segment 14 for FL display
81	P67/FL07	P15	O	Segment 15 for FL display
82	P66/FL06	P16	O	Segment 16 for FL display
83	P65/FL05	P17	O	Segment 17 for FL display
84	P64/FL04	P18	O	Segment 18 for FL display

Pin No.	Port	Pin Name	I/O	Function
85	P63/FL03	P19	O	Segment 19 for FL display
86	P62/FL02	P20	O	Segment 20 for FL display
87	P61/FL01	P21	O	Segment 21 for FL display
88	P60/FL00	P22	O	Segment 22 for FL display
89	VEE	VP	O	Power supply for FL display
90	P107/AN7	LIMDT	I	Limiter DC detect input
91	P106/AN6	PRV	I	PS (power voltage) protection AD value detect input
92	P105/AN5	PRD	I	DC (power amp voltage) protection AD value detect input
93	P104/AN4	METER	I	Tuner meter AD value input
94	P103/AN3	NC	O	No connection
95	P102/AN2	/FMT	O	Full mute output (L: ON)
96	P101/AN1	KEY2	I	Key 2 AD data value input
97	AVSS	MG		Ground
98	P100/AN0	KEY1	I	Key 1 AD data value input
99	VREF	+5M		Standard power supply for AD input
100	AVCC	+5BU		+5V power supply

**IC107 : BU2090**

**Serial Input/Parallel Output Driver for Output port expansion**

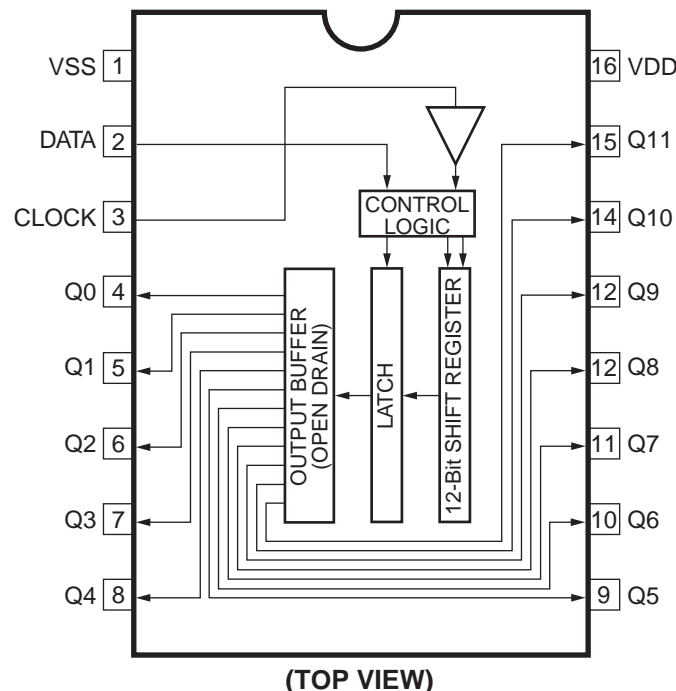

Pin No.	Port	Pin Name	I/O	Function
1	VSS	VSS		Ground
2	DATA	DTB	I	Control data input
3	CLOCK	CKB	I	Control clock input
4	Q0	SW1	O	Video select data output 1-5(*) for video input selector
5	Q1	SW2	O	
6	Q2	SW3	O	
7	Q3	SW4	O	
8	Q4	SW5	O	
9	Q5	/CONT1	O	Limiter control data output 1,2
10	Q6	/CONT2	O	
11	Q7	/-10dB	O	-10dB control data output (L : -10dB)
12	Q8	/ICAC	O	Initial clear output for AC3D2av
13	Q9	NC	O	Unconnected
14	Q10	NC	O	Unconnected
15	Q11	/T-MUTE	O	Tuner mute data output (L : Mute on)
16	VDD	VDD		+5V power supply

\* Video input Selector Control (H=High, L=Low, X=Don't care)

Video Input	SW1 (Pin4)	SW2 (Pin5)	SW3 (Pin6)	SW4 (Pin7)	SW5 (Pin8)
CBL/SAT	H	L	X	L	H
D-TV	H	H	X	L	H
DVD/LD	H	L	L	H	H
VCR	L	H	X	X	H
V-AUX	H	L	H	H	H
OFF	L	L	X	X	L

IC3 : YSD917 (DIR5)

Digital Format Interface Receiver

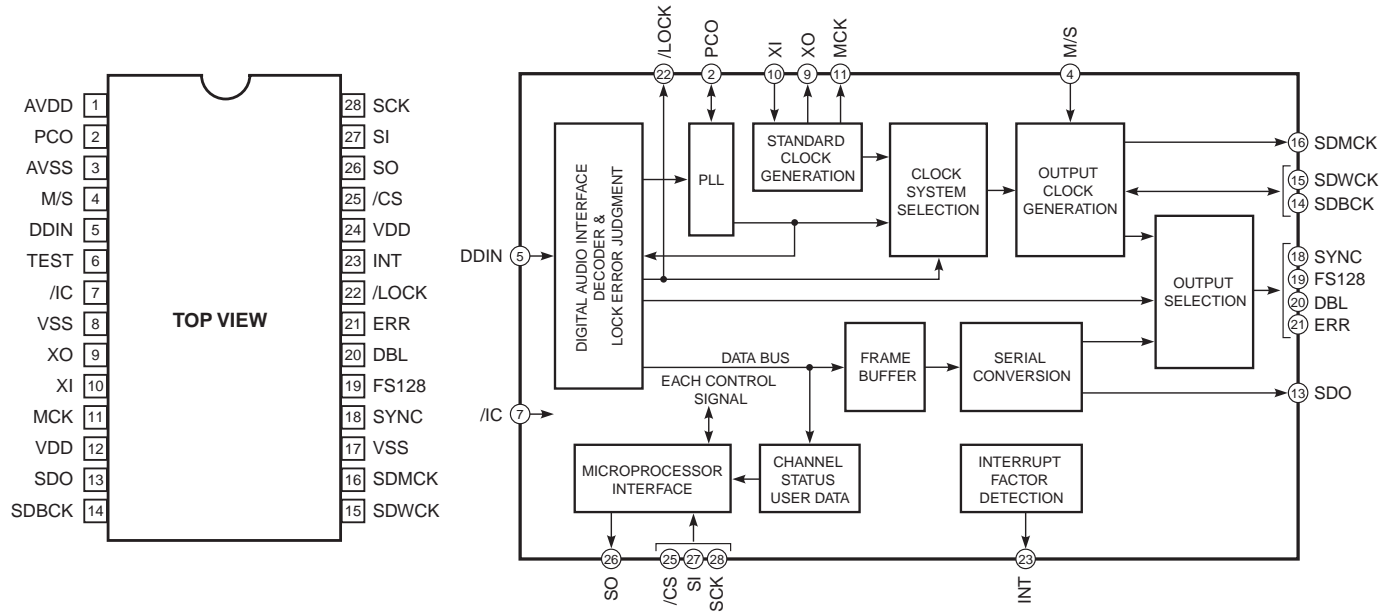

Pin No.	Pin Name	I/O	Function
1	AVDD		Power supply
2	PCO	I/O	PLL phase comparison output
3	AVSS		Ground
4	M/S	I	Unconnected
5	DDIN	I	Digital audio data input
6	TEST		Unconnected
7	/IC	I	Initial clear input from microcomputer
8	VSS		Ground
9	XO	O	Crystal oscillator connection (24.576MHz)
10	XI	I	Crystal oscillator connection (24.576MHz)
11	MCK	O	Master clock output for AC3D2av
12	VDD		Power supply
13	SDO	O	Serial audio data output for AC3D2av
14	SDBCK	I/O	64fs bit clock output for microcomputer, CODEC, DAC
15	SDWCK	I/O	1fs word clock output for microcomputer, CODEC, DAC
16	SDMCK	O	256fs bit clock output for microcomputer, CODEC, DAC

Pin No.	Pin Name	I/O	Function
17	VSS		Ground
18	SYNC	O	Unconnected
19	FS128	O	Unconnected
20	DBL	O	Double speed sampling mode selection data output for microcomputer, CODEC, DAC
21	ERR	O	Unconnected
22	/LOCK	O	Unconnected
23	INT	O	Interrupt factor detect output for microcomputer
24	VDD		Power supply
25	/CS	I	Chip select input from microcomputer
26	SO	O	Serial data output for microcomputer
27	SI	I	Serial data input for microcomputer
28	SCK	I	Serial clock input from microcomputer

IC4 : YSS918D-F (AC3D2av)

DSP + AC-3(Dolby Digital)/ Pro Logic/ DTS Digital Surround Decoder

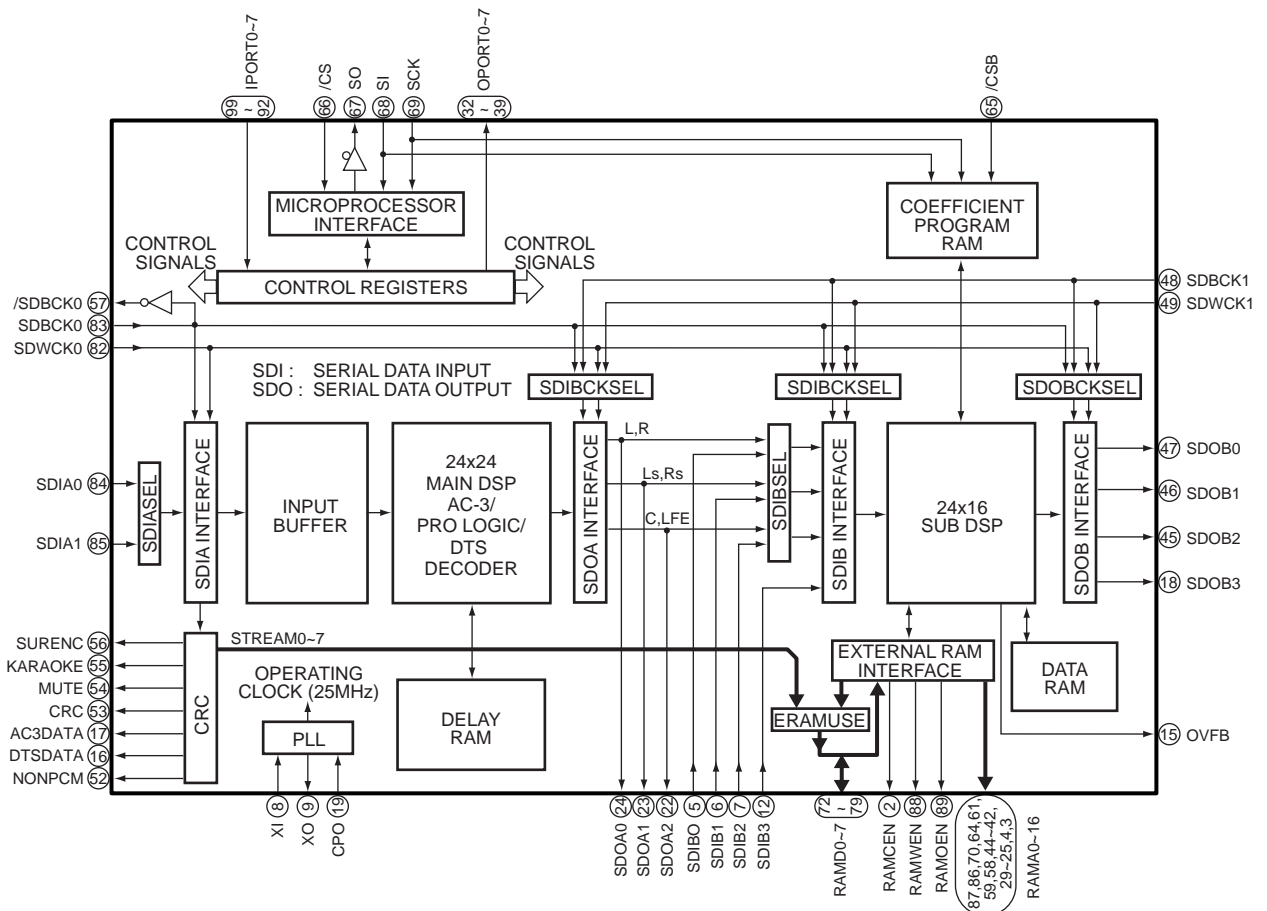
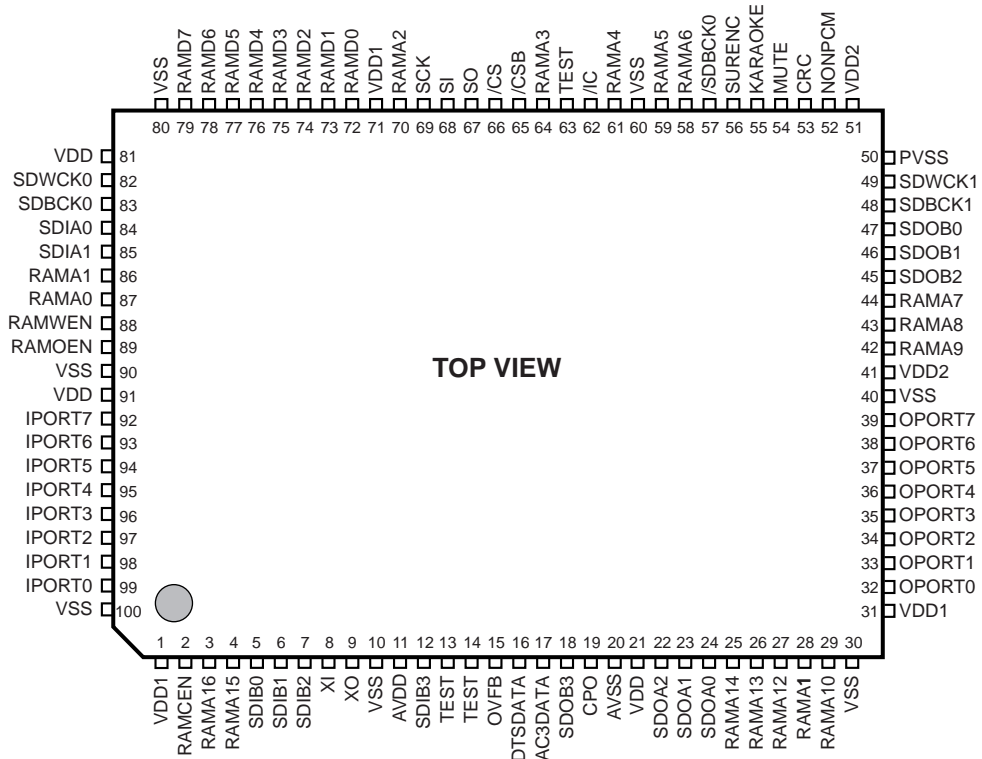

## IC4 : YSS918D-F (AC3D2av)

## DSP + AC-3(Dolby Digital)/ Pro Logic/ DTS Digital Surround Decoder

No.	Name	I/O	Function
1	VDD1		+5V power supply
2	RAMCEN	O	RAM chip enable output terminal (normally unconnected)
3	RAMA16	O	RAM address output terminal 16, connected to external 1M SRAM address
4	RAMA15	O	RAM address output terminal 15, connected to external 1M SRAM address
5	SDIB0	I	Serial data input B terminal 0 (normally connected to ground)
6	SDIB1	I	Serial data input B terminal 1 (normally connected to ground)
7	SDIB2	I	Serial data input B terminal 2 (normally connected to ground)
8	XI	I	Crystal oscillator connection or external clock input terminal, connected to external DIR5 master clock output
9	XO	O	Crystal oscillator connection (normally unconnected)
10	VSS		Ground
11	AVDD		+3V power supply
12	SDIB3	I	Serial data input B terminal 3 (normally unconnected)
13	TEST		Test terminal (normally unconnected)
14	TEST		Test terminal (normally unconnected)
15	OVFB	O	Overflow detect terminal (normally unconnected)
16	DTSDATA	O	DTS data detect terminal (normally unconnected)
17	AC3DATA	O	AC-3 data detect terminal (normally unconnected)
18	SDOB3	O	Serial data output B terminal 3 (normally unconnected)
19	CPO	O	PLL output terminal (connected to AVSS through external analog filter)
20	AVSS		Ground
21	VDD		+3V power supply
22	SDOA2	O	Serial data output A terminal 2 (normally unconnected)
23	SDOA1	O	Serial data output A terminal 1 (normally unconnected)
24	SDOA0	O	Serial data output A terminal 0 connected to external ADC serial data input
25	RAMA14	O	RAM address terminal 14 output terminal, connected to external 1M SRAM address
26	RAMA13	O	RAM address terminal 13 output terminal, connected to external 1M SRAM address
27	RAMA12	O	RAM address terminal 12 output terminal, connected to external 1M SRAM address
28	RAMA11	O	RAM address terminal 11 output terminal, connected to external 1M SRAM address
29	RAMA10	O	RAM address terminal 10 output terminal, connected to external 1M SRAM address
30	VSS		Ground
31	VDD1		+5V power supply
32	OPORT0	O	Output expansion port terminal 0, digital input selector A output (DIA *)
33	OPORT1	O	Output expansion port terminal 1, digital input selector B output (DIB *)
34	OPORT2	O	Output expansion port terminal 2 (normally unconnected)
35	OPORT3	O	Output expansion port terminal 3, compulsive analog performance mode (KM1) output
36	OPORT4	O	Output expansion port terminal 4, connected to external CODEC initial clear input
37	OPORT5	O	Output expansion port terminal 5, PRO LOGIC decode output (H:PRO LOGIC decode)
38	OPORT6	O	Output expansion port terminal 6 (normally unconnected)
39	OPORT7	O	Output expansion port terminal 7 (normally unconnected)
40	VSS		Ground
41	VDD2		+3V power supply
42	RAMA9	O	RAM address output terminal 9, connected to external 1M SRAM address
43	RAMA8	O	RAM address output terminal 8, connected to external 1M SRAM address
44	RAMA7	O	RAM address output terminal 7, connected to external 1M SRAM address
45	SDOB2	O	Serial data output B terminal 2, connected to external CODEC PCM audio data output
46	SDOB1	O	Serial data output B terminal 1, connected to external CODEC PCM audio data output
47	SDOB0	O	Serial data output B terminal 0, connected to external CODEC PCM audio data output
48	SDBCK1	I	Serial data bit clock input terminal 1, connected to external DIR5 64fs bit clock output
49	SDWCK1	I	Serial data word clock input terminal 1, connected to external DIR5 1fs word clock output
50	VSS		Ground

\* Digital Input  
Selector Control  
(H=1, L=0)

Digital Input	DIB(Pin33)	DIA(Pin32)
NONE	0	0
DVD/LD	0	1
CBL/SAT	1	0
D-TV	1	1

## IC4 : YSS918D-F (AC3D2av)

## DSP + AC-3(Dolby Digital)/ Pro Logic/ DTS Digital Surround Decoder

No.	Name	I/O	Function
51	VDD2		+3V power supply
52	NONPCM	O	Non-PCM data output terminal, non-PCM data detect output
53	CRC	O	CRC output terminal (normally unconnected)
54	MUTE	O	Mute output terminal, connected to external microcomputer data mute detect input
55	KARAOKE	O	Karaoke output terminal (normally unconnected)
56	SURENC	O	Surround encoder output terminal (normally unconnected)
57	/SDBCK0	O	Inverted signal of serial data bit clock output terminal 0 (normally unconnected)
58	RAMA6	O	RAM address output terminal 6, connected to external 1M SRAM address
59	RAMA5	O	RAM address output terminal 5, connected to external 1M SRAM address
60	VSS		Ground
61	RAMA4	O	RAM address output terminal 4, connected to external 1M SRAM address
62	/IC	I	Initial clear input terminal, connected to external output port expansion IC initial clear output
63	TEST		Test terminal (normally unconnected)
64	RAMA3	O	RAM address output terminal 3, connected to external 1M SRAM address
65	/CSB	I	Chip select B input terminal, connected to external microcomputer chip enable output 2
66	/CS	I	Chip select input terminal, connected to external microcomputer chip enable output 1
67	SO	O	Serial data output terminal, connected to external microcomputer serial data input
68	SI	I	Serial data input terminal, connected to external microcomputer serial data output
69	SCK	I	Serial clock input terminal, connected to external microcomputer serial clock output
70	RAMA2	O	RAM address output terminal 2, connected to external 1M SRAM address
71	VDD1		+5V power supply
72	RAMD0	I/O	RAM data bus terminal 0, connected to external 1M SRAM data
73	RAMD1	I/O	RAM data bus terminal 1, connected to external 1M SRAM data
74	RAMD2	I/O	RAM data bus terminal 2, connected to external 1M SRAM data
75	RAMD3	I/O	RAM data bus terminal 3, connected to external 1M SRAM data
76	RAMD4	I/O	RAM data bus terminal 4, connected to external 1M SRAM data
77	RAMD5	I/O	RAM data bus terminal 5, connected to external 1M SRAM data
78	RAMD6	I/O	RAM data bus terminal 6, connected to external 1M SRAM data
79	RAMD7	I/O	RAM data bus terminal 7, connected to external 1M SRAM data
80	VSS		Ground
81	VDD2		+3V power supply
82	SDWCK0	I	Serial data word clock input terminal 0, connected to external DIR5 1fs word clock output
83	SDBCK0	I	Serial data bit clock input terminal 0, connected to external DIR5 64fs bit clock output
84	SDIA0	I	Serial data input A terminal 0, AC-3/DTS bit stream (or PCM) data input, connected to external DIR5 audio data output
85	SDIA1	I	Serial data input A terminal 1, connected to external CODEC audio data output
86	RAMA1	O	RAM address output terminal 1, connected to external 1M SRAM address
87	RAMA0	O	RAM address output terminal 0, connected to external 1M SRAM address
88	RAMWEN	O	RAM write enable output terminal, connected to external 1M SRAM write enable
89	RAMOEN	O	RAM output enable output terminal, connected to external 1M SRAM output enable
90	VSS		Ground
91	VDD		+3V power supply
92	IPORT7	I	Input expansion port terminal 7, DVD coaxial/optical select
93	IPORT6	I	Input expansion port terminal 6, DBS coaxial/optical select
94	IPORT5	I	Input expansion port terminal 5 (normally connected to ground)
95	IPORT4	I	Input expansion port terminal 4, digital sampling frequency select (H:96kHz, L:Non 96kHz)
96	IPORT3	I	Input expansion port terminal 3, Front mix select (H: Outside, L: Inside)
97	IPORT2	I	Input expansion port terminal 2, RF select (H: Exist, L:None)
98	IPORT1	I	Input expansion port terminal 1, DTS select (H: DTS (YSS918), L: Non DTS (YSS908))
99	IPORT0	I	Input expansion port terminal 0, SRAM select (H: 1M, L: 256k)
100	VSS		Ground

IC5 : IS61C1024-20J (1M SRAM)

131072-word x 8-bit High Speed Static RAM

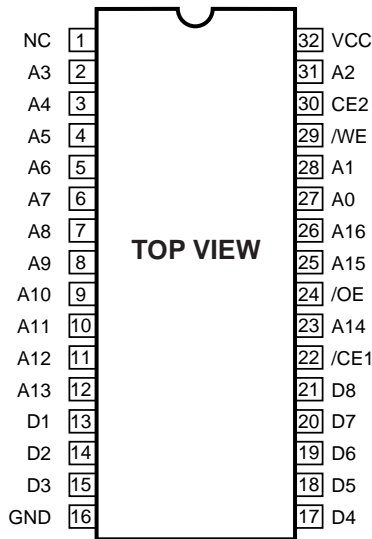

**NOTE)**

- A0-A16: Address input
- D1-D8: Data input/output
- /CE1,CE2: Chip enable input 1,2
- /OE: Output enable input
- /WE: Write enable input

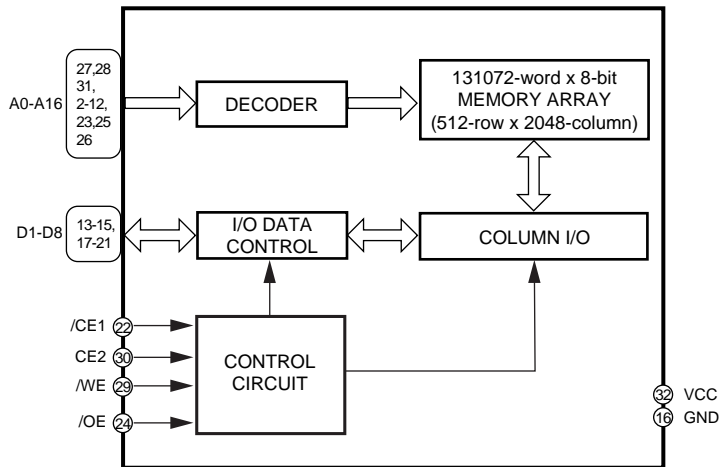

Mode	/WE	/CE1/CE2	/OE	Data I/O	Power
Not Selected (Power-down)	X	H	X	High impedance	Standby
	X	X	L	High impedance	On
Output Disabled	H	L	H	High impedance	On
Read	H	L	H	Output	On
Write	L	L	H	Input	On

**NOTE)** H: High Level L: Low level X: Don't care

IC7 : AK4324-VF-E2 (DAC)

1-bit D/A Converter

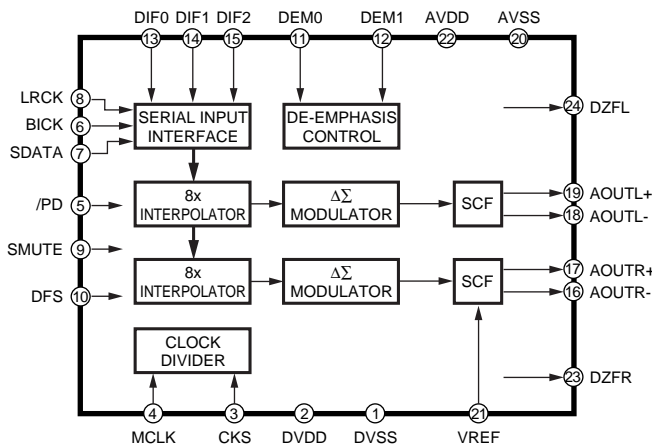
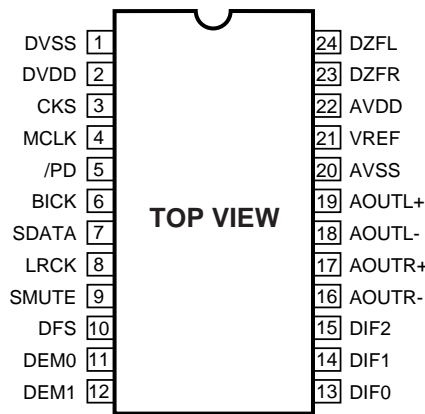

Pin No.	Pin Name	I/O	Function
1	DVSS		Ground (digital)
2	DVDD		Power supply (digital)
3	CKS	I	Master clock (MCLK) select input (Fixed L) Normal speed (L:256fs, H:384fs) High speed (L:128fs, H:192fs)
4	MCLK	I	256fs bit clock input from DIR5
5	/PD	I	Power-down and reset, initial clear input from AC3D2av (L:Reset)
6	BICK	I	64fs bit clock input from DIR5
7	SDATA	I	Serial data input from AC3D2av
8	LRCK	I	1fs word clock input from DIR5
9	SMUTE	I	Soft mute detect input (H:Soft mute, L:off)
10	DFS	I	Double speed sampling mode select input from DIR5 (L:Normal speed, H:High speed)

Pin No.	Pin Name	I/O	Function
11	DEM0	I	De-emphasis frequency select input 0 (Fixed H)
12	DEM1	I	De-emphasis frequency select input 1 (Fixed L)
13	DIF0	I	Digital input format input 0 (Fixed L)
14	DIF1	I	Digital input format input 1 (Fixed H)
15	DIF2	I	Digital input format input 2 (Fixed L)
16	AOUTR-	O	Rch negative analog output
17	AOUTR+	O	Rch positive analog output
18	AOUTL-	O	Lch negative analog output
19	AOUTL+	O	Lch positive analog output
20	AVSS		Ground (analog)
21	VREF	I	Reference voltage input
22	AVDD		Power supply (analog)
23	DZFR	O	Rch zero input detect output
24	DZFL	O	Lch zero input detect output

**IC6 : AK4526A-VQ (CODEC. ADC/DAC)**  
**20-bit 6-channel A/D, D/A Converter**

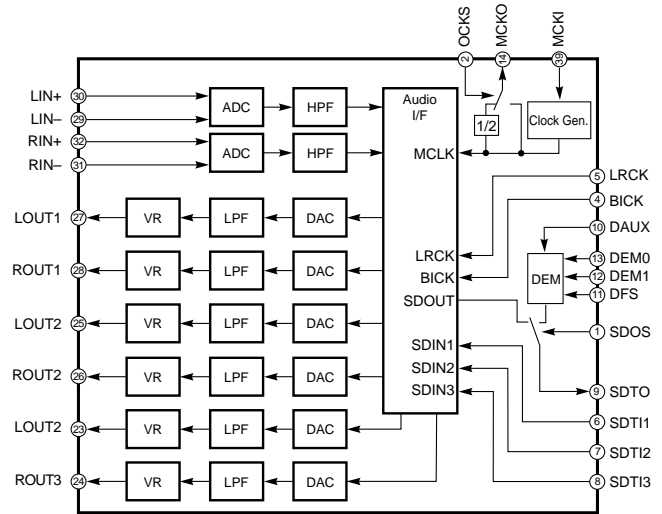
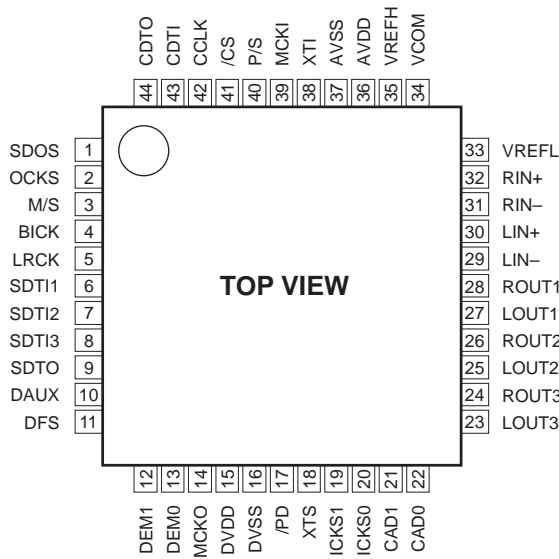

Pin No.	Pin Name	I/O	Function
1	SDOS	I	Fixed L
2	OCKS	I	Fixed L
3	M/S	I	Fixed L
4	BICK	I	Audio serial data clock, 64fs bit clock input from microcomputer
5	LRCK	I	L/R channel clock, 1fs word clock input from microcomputer
6	SDTI1	I	DAC Audio serial data input 1-3, PCM input from AC3D2av
7	SDTI2	I	
8	SDTI3	I	
9	SDTO	O	Audio serial data output, audio data for AC3D2av
10	DAUX	I	Fixed L
11	DFS	I	Double speed sampling mode selection data input from DIR5
12	DEM1	I	De-emphasis frequency select input 1 (Fixed L)
13	DEM0	I	De-emphasis frequency select input 0 (Fixed L)
14	MCKO	O	Unconnected
15	DVDD		Power supply (digital)
16	DVSS		Ground (digital)
17	/PD	I	Power-down and reset, initial clear input from AC3D2av
18	XTS	I	Connected to ground (analog)
19	ICKS1	I	Connected to ground (analog)
20	ICKS0	I	Connected to ground (analog)
21	CAD1	I	Connected to ground (analog)
22	CAD0	I	Connected to ground (analog)

Pin No.	Pin Name	I/O	Function
23	LOUT3	O	Lch analog output 3, for CENTER
24	ROUT3	O	Rch analog output 3, for LFE
25	LOUT2	O	Lch analog output 2, for REAR
26	ROUT2	O	Rch analog output 2, for REAR
27	LOUT1	O	Lch analog output 1, for FRONT
28	ROUT1	O	Rch analog output 1, for FRONT
29	LIN-	I	Lch negative analog input, from MAIN
30	LIN+	I	Lch positive analog input, from MAIN
31	RIN-	I	Rch negative analog input, from MAIN
32	RIN+	I	Rch positive analog input, from MAIN
33	VREFL	I	Reference voltage (Low) input (analog)
34	VCOM	O	Common voltage output
35	VREFH	I	Reference voltage (High) input (analog)
36	AVDD		Power supply (analog)
37	AVSS		Ground (analog)
38	XTI		Unconnected
39	MCKI	I	External master clock input, 256fs bit clock input from DIR5
40	P/S	I	Fixed L
41	/CS	I	Chip select in serial mode, chip enable from microcomputer
42	CCLK	I	Control data clock in serial mode, serial clock from microcomputer
43	CDTI	I	Control data input in serial mode, serial data from microcomputer
44	CDTO	O	Unconnected



# DISPLAY DATA

## V501 : 16-BT-71GK (V4193300)



### PIN CONNECTION

Pin No.	1	2	3	4	5	6	7	8	9	10	11	12	13	14	15	16	17	18	19	20	21	22	23	24	25
CONNECTION	F1	F1	NP	NP	NP	NP	NP	NP	NP	NP	NP	NP	NP	NP	NP	NP	NP	Fd	Fd	NP	NP	P22	P21	P20	P19
Pin No.	26	27	28	29	30	31	32	33	34	35	36	37	38	39	40	41	42	43	44	45	46	47	48	49	50
CONNECTION	P18	P17	P16	P15	P14	P13	P12	P11	P10	P9	P8	P7	P6	P5	P4	P3	P2	P1	NP	NP	16G	15G	14G	13G	12G
Pin No.	51	52	53	54	55	56	57	58	59	60	61	62	63	64	65										
CONNECTION	11G	10G	9G	8G	7G	6G	5G	4G	3G	2G	1G	NP	NP	F2	F2										

**NOTE** 1) F1, F2..... Filament  
 2) NP..... No pin  
 3) P1~P22 .....Segment  
 4) 1G~16G..... Grid  
 5) Fd terminals are to be supplied through 51kΩ from Ec.  
 6) Field of vision is a minimum of 23° from the lower side.

### GRID ASSIGNMENT

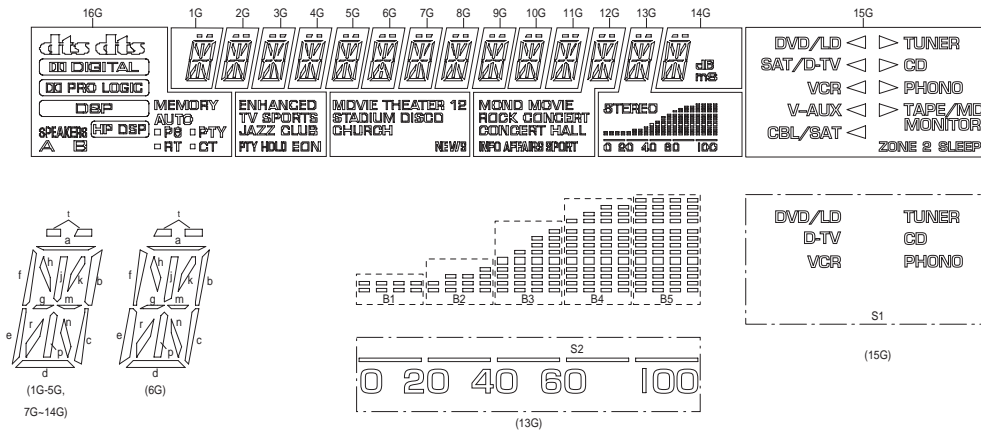

### ANODE CONNECTION

	16G	15G	14G	13G	12G	11G	10G	9G	8G	7G	6G	5G	4G	3G	2G	1G
P1	CLKS (LEFT)	(TUNER)	a	a	a	a	a	a	a	a	a	a	a	a	a	a
P2	(RIGHT) CLKS	(CD)	b	b	b	b	b	b	b	b	b	b	b	b	b	b
P3	DIGITAL	(PHONO)	c	c	c	c	c	c	c	c	c	c	c	c	c	c
P4	PRO LOGIC	(TAPE/MD)	d	d	d	d	d	d	d	d	d	d	d	d	d	d
P5	DSP	(CBL/SAT)	e	e	e	e	e	e	e	e	e	e	e	e	e	e
P6	HP DSP	(V-AUX)	f	f	f	f	f	f	f	f	f	f	f	f	f	f
P7	SPEAKERS	(VCR)	g	g	g	g	g	g	g	g	g	g	g	g	g	g
P8	A	(SAT/D-TV)	h	h	h	h	h	h	h	h	h	h	h	h	h	h
P9	B	(DVD/LD)	j	j	j	j	j	j	j	j	j	j	j	j	j	j
P10	MEMORY	S1	k	k	k	k	k	k	k	k	k	k	k	k	k	k
P11	AUTO	SAT/	m	m	m	m	m	m	m	m	m	m	m	m	m	m
P12	(PS)	V-AUX	n	n	n	n	n	n	n	n	n	n	n	n	n	n
P13	PS	CBL/SAT	p	p	p	p	p	p	p	p	p	p	p	p	p	p
P14	(PTY)	TAPE/MD	r	r	r	r	r	r	r	r	r	r	r	r	r	r
P15	PTY	MONITOR	t	t	t	t	t	t	t	t	t	t	t	t	t	t
P16	(RT)	ZONE 2	dB	STEREO	MONO MOVIE	MOVIE THEATER	ENHANCED	-	-	-	-	-	-	-	-	-
P17	RT	SLEEP	ms	B1	ROCK CONCERT	1	TV SPORTS	-	-	-	-	-	-	-	-	-
P18	(CT)	-	-	B2	CONCERT HALL	2	JAZZ CLUB	-	-	-	-	-	-	-	-	-
P19	CT	-	-	B3	INFO	STADIUM	PTY HOLD	-	-	-	-	-	-	-	-	-
P20	-	-	-	B4	AFFAIRS	DISCO	EON	-	-	-	-	-	-	-	-	-
P21	-	-	-	B5	SPORT	CHURCH	-	-	-	-	-	-	-	-	-	-
P22	-	-	-	S2	-	NEWS	-	-	-	-	-	-	-	-	-	-

# BLOCK DIAGRAM (1/2)

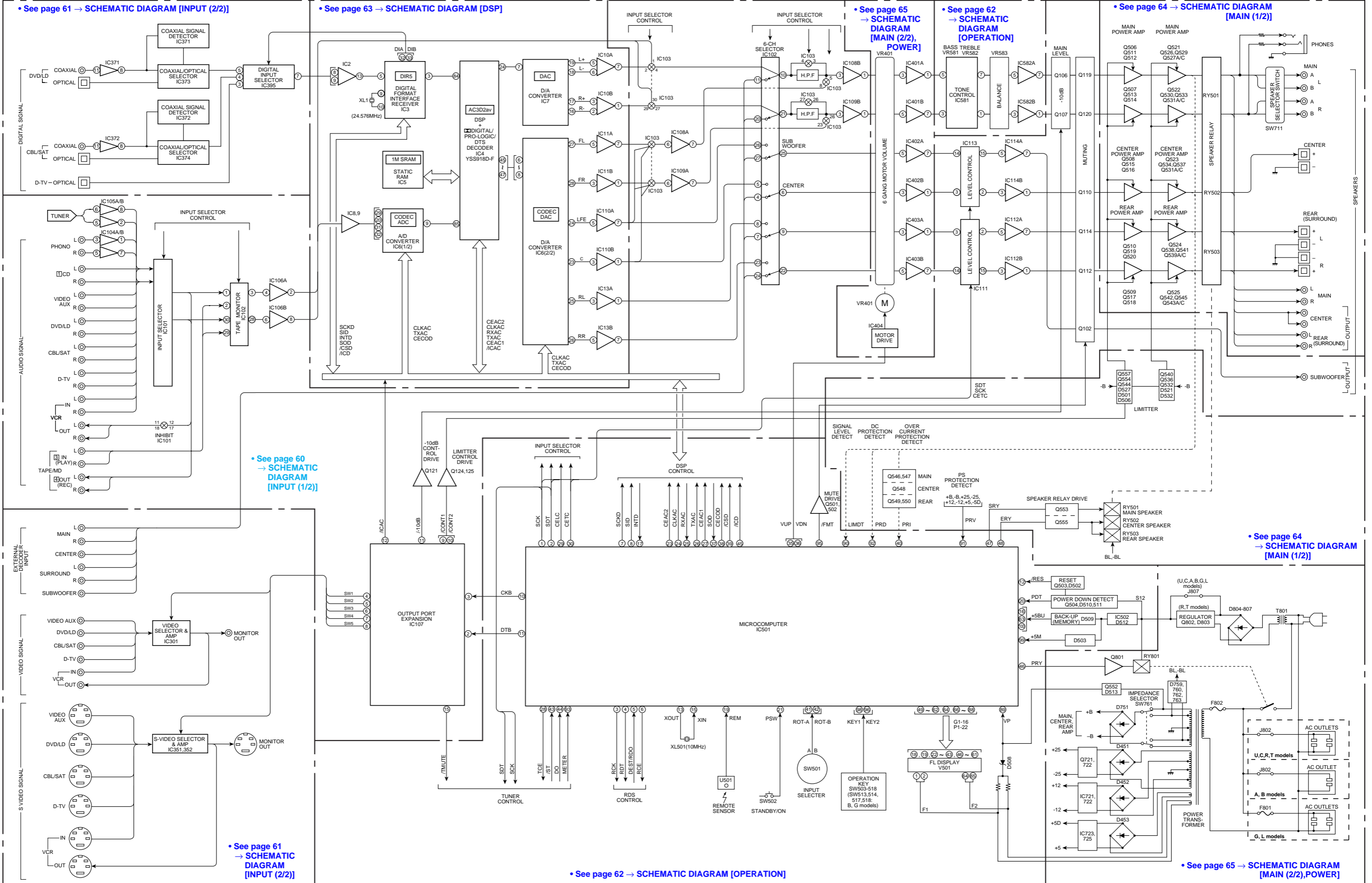

■ BLOCK DIAGRAM (2/2)

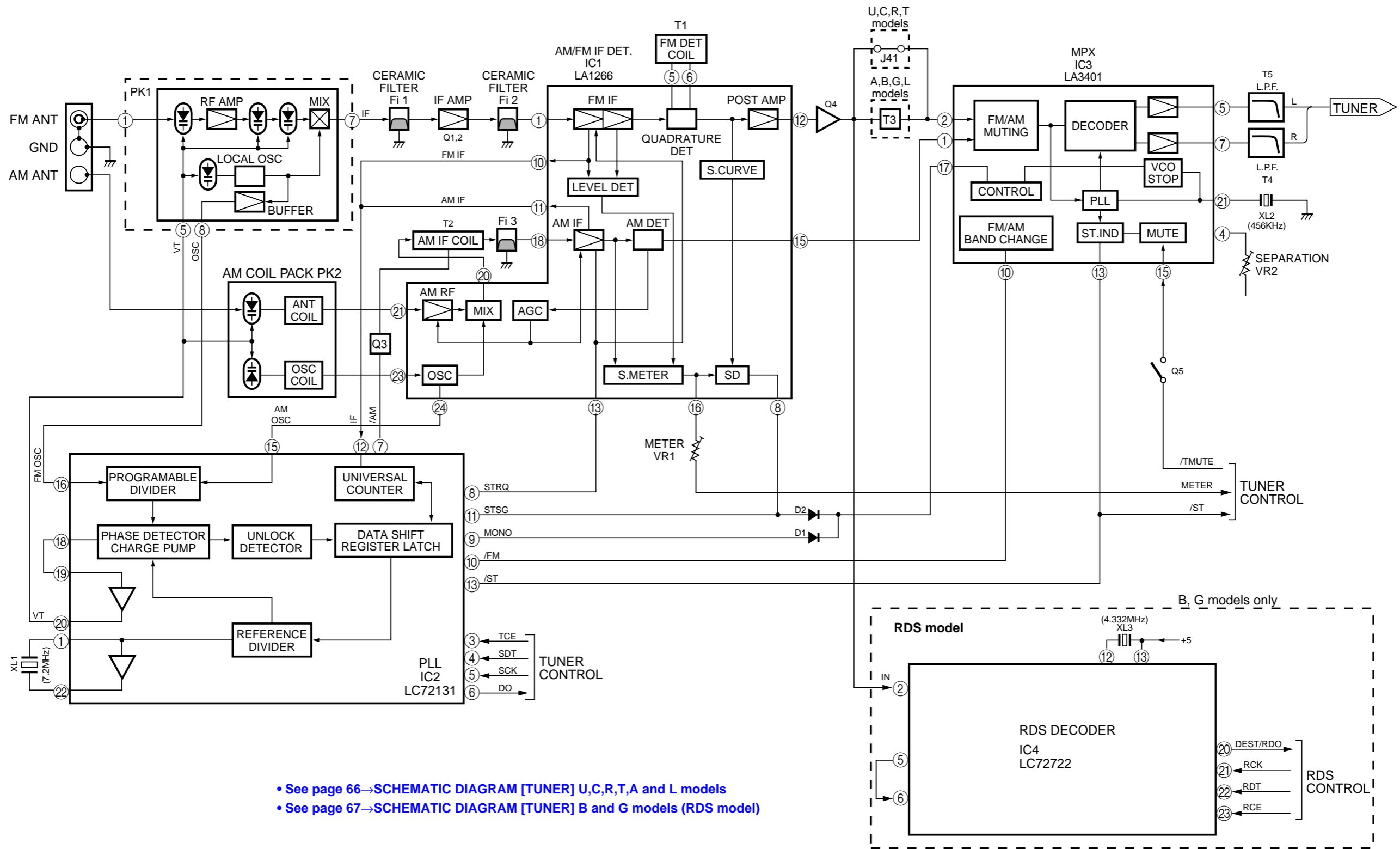

- See page 66→SCHEMATIC DIAGRAM [TUNER] U,C,R,T,A and L models
- See page 67→SCHEMATIC DIAGRAM [TUNER] B and G models (RDS model)

# PARTS LIST

## ■ ELECTRICAL PARTS

### ■ WARNING

Components having special characteristics are marked  $\triangle$  and must be replaced with parts having specifications equal to those originally installed.

- Carbon resistors (1/6W or 1/4W) are not included in the ELECTRICAL PARTS List. For the part Nos. of the carbon resistors, refer to page 86.
- Chip resistors are listed on page 81.

### ABBREVIATIONS IN THIS LIST ARE AS FOLLOWS:

C. A. EL. CHP	: CHIP ALUMI. ELECTROLYTIC CAP	LED. DSPLY	: LED DISPLAY
C. CE	: CERAMIC CAP	LED. INFRD	: LED, INFRARED
C. CE. ARRAY	: CERAMIC CAP ARRAY	MODUL. RF	: MODULATOR, RF
C. CE. CHP	: CHIP CERAMIC CAP	PHOT. CPL	: PHOTO COUPLER
C. CE. ML	: MULTILAYER CERAMIC CAP	PHOT. INTR	: PHOTO INTERRUPTER
C. CE. M. CHP	: CHIP MULTILAYER CERAMIC CAP	PHOT. RFLCT	: PHOTO REFLECTOR
C. CE. SAFTY	: RECOGNIZED CERAMIC CAP	PIN. TEST	: PIN, TEST POINT
C. CE. TUBLR	: CERAMIC TUBULAR CAP	PLST. RIVET	: PLASTIC RIVET
C. CE. SMI	: SEMI CONDUCTIVE CERAMIC CAP	R. ARRAY	: RESISTOR ARRAY
C. EL	: ELECTROLYTIC CAP	R. CAR	: CARBON RESISTOR
C. MICA	: MICA CAP	R. CAR. CHP	: CHIP RESISTOR
C. ML. FLM	: MULTILAYER FILM CAP	R. CAR.FP	: FLAME PROOF CARBON RESISTOR
C. MP	: METALLIZED PAPER CAP	R. FUS	: FUSABLE RESISTOR
C. MYLAR	: MYLAR FILM CAP	R. MTL. CHP	: CHIP METAL FILM RESISTOR
C. MYLAR. ML	: MULTILAYER MYLAR FILM CAP	R. MTL. FILM	: METAL FILM RESISTOR
C. PAPER	: PAPER CAPACITOR	R. MTL. OXD	: METAL OXIDE FILM RESISTOR
C. PLS	: POLYSTYRENE FILM CAP	R. MTL. PLAT	: METAL PLATE RESISTOR
C. POL	: POLYESTER FILM CAP	RSNR. CE	: CERAMIC RESONATOR
C. POLY	: POLYETHYLENE FILM CAP	RSNR. CRYST	: CRYSTAL RESONATOR
C. PP	: POLYPROPYLENE FILM CAP	R. TW. CEM	: TWIN CEMENT FIXED RESISTOR
C. TNTL	: TANTALUM CAP	R. WW	: WIRE WOUND RESISTOR
C. TNT. CHP	: CHIP TANTALUM CAP	SCR. BND. HD	: BIND HEAD B-TITE SCREW
C. TRIM	: TRIMMER CAP	SCR. BW. HD	: BW HEAD TAPPING SCREW
CN	: CONNECTOR	SCR. CUP	: CUP TITE SCREW
CN. BS. PIN	: CONNECTOR, BASE PIN	SCR. TERM	: SCREW TERMINAL
CN. CANNON	: CONNECTOR, CANNON	SCR. TR	: SCREW, TRANSISTOR
CN. DIN	: CONNECTOR, DIN	SUPRT. PCB	: SUPPORT, P. C. B.
CN. FLAT	: CONNECTOR, FLAT CABLE	SURG. PRTCT	: SURGE PROTECTOR
CN. POST	: CONNECTOR, BASE POST	SW. TACT	: TACT SWITCH
COIL. MX. AM	: COIL, AM MIX	SW. LEAF	: LEAF SWITCH
COIL. AT. FM	: COIL, FM ANTENNA	SW. LEVER	: LEVER SWITCH
COIL. DT. FM	: COIL, FM DETECT	SW. MICRO	: MICRO SWITCH
COIL. MX. FM	: COIL, FM MIX	SW. PUSH	: PUSH SWITCH
COIL. OUTPT	: OUTPUT COIL	SW. RT. ENC	: ROTARY ENCODER
DIOD. ARRAY	: DIODE ARRAY	SW. RT. MTR	: ROTARY SWITCH WITH MOTOR
DIODE. BRG	: DIODE BRIDGE	SW. RT	: ROTARY SWITCH
DIODE. CHP	: CHIP DIODE	SW. SLIDE	: SLIDE SWITCH
DIODE. VAR	: VARACTOR DIODE	TERM. SP	: SPEAKER TERMINAL
DIOD. Z. CHP	: CHIP ZENER DIODE	TERM. WRAP	: WRAPPING TERMINAL
DIODE. ZENR	: ZENER DIODE	THRMST. CHP	: CHIP THERMISTOR
DSCR. CE	: CERAMIC DISCRIMINATOR	TR. CHP	: CHIP TRANSISTOR
FER. BEAD	: FERRITE BEADS	TR. DGT	: DIGITAL TRANSISTOR
FER. CORE	: FERRITE CORE	TR. DGT. CHP	: CHIP DIGITAL TRANSISTOR
FET. CHP	: CHIP FET	TRANS	: TRANSFORMER
FL. DSPLY	: FLUORESCENT DISPLAY	TRANS. PULS	: PULSE TRANSFORMER
FLTR. CE	: CERAMIC FILTER	TRANS. PWR	: POWER TRANSFORMER ASS'y
FLTR. COMB	: COMB FILTER MODULE	TUNER. AM	: TUNER PACK, AM
FLTR. LC. RF	: LC FILTER, EMI	TUNER. FM	: TUNER PACK, FM
GND. MTL	: GROUND PLATE	TUNER. PK	: FRONT-END TUNER PACK
GND. TERM	: GROUND TERMINAL	VR	: ROTARY POTENTIOMETER
HOLDER. FUS	: FUSE HOLDER	VR. MTR	: POTENTIOMETER WITH MOTOR
IC. PRTCT	: IC PROTECTOR	VR. SW	: POTENTIOMETER WITH ROTARY SW
JUMPER. CN	: JUMPER CONNECTOR	VR. SLIDE	: SLIDE POTENTIOMETER
JUMPER. TST	: JUMPER, TEST POINT	VR. TRIM	: TRIMMER POTENTIOMETER
L. DTCT	: LIGHT DETECTING MODULE		
L. EMIT	: LIGHT EMITTING MODULE		

**Note)** Those parts marked with "#" are not included in the P. C. B. Ass'y.

## P. C. B. DSP

Schm Ref	PART NO.	Description			
*	V4800100	P.C.B.	DSP		
* CB1	VQ044300	CN.BS.PIN	7P		
CB3	VQ044900	CN.BS.PIN	19P		
CB6	VQ044600	CN.BS.PIN	13P		
C1	UB245100	C.CE.M.CHP	0.1uF	25V	
C2	UB052100	C.CE.M.CHP	100pF	50V	
C3	UB052100	C.CE.M.CHP	100pF	50V	
C4	UB245100	C.CE.M.CHP	0.1uF	25V	
C5	UB052100	C.CE.M.CHP	100pF	50V	
C6	UB052100	C.CE.M.CHP	100pF	50V	
C7	UB245100	C.CE.M.CHP	0.1uF	25V	
C8	UB051100	C.CE.M.CHP	10pF	50V	
C9	UB013100	C.CE.M.CHP	1000pF	50V	
C10	UB245100	C.CE.M.CHP	0.1uF	25V	
C11	UR818100	C.EL	100uF	6.3V	
C12	UB245100	C.CE.M.CHP	0.1uF	25V	
C20	VJ900700	C.CE.M.CHP	33pF	50V	
C21	UB044220	C.CE.M.CHP	0.022uF	50V	
C22	UA953470	C.MYLAR	4700pF	50V	
C23	VJ900700	C.CE.M.CHP	33pF	50V	
C32	UB245100	C.CE.M.CHP	0.1uF	25V	
C33	UB245100	C.CE.M.CHP	0.1uF	25V	
C34	UB245100	C.CE.M.CHP	0.1uF	25V	
C35	UB245100	C.CE.M.CHP	0.1uF	25V	
C44	UB245100	C.CE.M.CHP	0.1uF	25V	
C45	UB245100	C.CE.M.CHP	0.1uF	25V	
C46	UB245100	C.CE.M.CHP	0.1uF	25V	
C47	UR818100	C.EL	100uF	6.3V	
C48	VJ900700	C.CE.M.CHP	33pF	50V	
C50	UR818330	C.EL	330uF	6.3V	
C51	UB245100	C.CE.M.CHP	0.1uF	25V	
C52	UR818330	C.EL	330uF	6.3V	
C53	UB245100	C.CE.M.CHP	0.1uF	25V	
C54	UB245100	C.CE.M.CHP	0.1uF	25V	
C55	UR829100	C.EL	1000uF	10V	
C56	UR818330	C.EL	330uF	6.3V	
C59	UR829100	C.EL	1000uF	10V	
C61	UB012470	C.CE.M.CHP	470pF	50V	
C62	UB245100	C.CE.M.CHP	0.1uF	25V	
C63	UB245100	C.CE.M.CHP	0.1uF	25V	
C64	UR818330	C.EL	330uF	6.3V	
C65	UB245100	C.CE.M.CHP	0.1uF	25V	
C66	UR818330	C.EL	330uF	6.3V	
C67	UB245100	C.CE.M.CHP	0.1uF	25V	
C68	UB245100	C.CE.M.CHP	0.1uF	25V	
C69	UR818330	C.EL	330uF	6.3V	
C70	UB245100	C.CE.M.CHP	0.1uF	25V	
C71	VG286200	C.EL	100uF	10V	
C72	VG286200	C.EL	100uF	10V	
C73	UB245100	C.CE.M.CHP	0.1uF	25V	
C74	VG288500	C.EL	10uF	50V	
C75	UB245100	C.CE.M.CHP	0.1uF	25V	
C76	VG286200	C.EL	100uF	10V	

\* New Parts

Schm Ref	PART NO.	Description			
C77	UB245100	C.CE.M.CHP	0.1uF	25V	
C78	UB245100	C.CE.M.CHP	0.1uF	25V	
C79	UB245100	C.CE.M.CHP	0.1uF	25V	
C82	VG286200	C.EL	100uF	10V	
C85	UB245100	C.CE.M.CHP	0.1uF	25V	
C86	UB245100	C.CE.M.CHP	0.1uF	25V	
C88	UA953150	C.MYLAR	1500pF	50V	
C89	UA953150	C.MYLAR	1500pF	50V	
C90	VG288500	C.EL	10uF	50V	
C91	VG288500	C.EL	10uF	50V	
C92	VG288500	C.EL	10uF	50V	
C93	VG288500	C.EL	10uF	50V	
C94	VG288500	C.EL	10uF	50V	
C95	VG288500	C.EL	10uF	50V	
C96	VG288500	C.EL	10uF	50V	
C97	VG288500	C.EL	10uF	50V	
C98	VG288500	C.EL	10uF	50V	
C99	VG288500	C.EL	10uF	50V	
C100	UA952100	C.MYLAR	100pF	50V	
C101	UA952100	C.MYLAR	100pF	50V	
* C102	UA952150	C.MYLAR	150pF	50V	
* C103	UA952150	C.MYLAR	150pF	50V	
C104	VG288500	C.EL	10uF	50V	
C106	UA952390	C.MYLAR	390pF	50V	
C107	UA952390	C.MYLAR	390pF	50V	
C109	VG288500	C.EL	10uF	50V	
C110	VG288500	C.EL	10uF	50V	
C111	UB245100	C.CE.M.CHP	0.1uF	25V	
C112	VG286500	C.EL	470uF	10V	
* C113	VG286900	C.EL	220uF	10V	
C115	VG288500	C.EL	10uF	50V	
C116	VG288500	C.EL	10uF	50V	
C117	VG288500	C.EL	10uF	50V	
C118	UA952390	C.MYLAR	390pF	50V	
C119	UA952390	C.MYLAR	390pF	50V	
C120	VG288500	C.EL	10uF	50V	
C121	VG288500	C.EL	10uF	50V	
C122	UA952100	C.MYLAR	100pF	50V	
C123	VG287300	C.EL	22uF	50V	
C124	VG288500	C.EL	10uF	50V	
C125	VG287300	C.EL	22uF	50V	
C126	UA952100	C.MYLAR	100pF	50V	
C127	VG288500	C.EL	10uF	50V	
C128	VG288500	C.EL	10uF	50V	
* C129	V4578900	C.EL	47uF	35V	
* C130	V4578900	C.EL	47uF	35V	
C131	UB052100	C.CE.M.CHP	100pF	50V	
C132	UB052100	C.CE.M.CHP	100pF	50V	
C133	UB052100	C.CE.M.CHP	100pF	50V	
C134	UB052100	C.CE.M.CHP	100pF	50V	
C135	UB052100	C.CE.M.CHP	100pF	50V	
C136	UB052100	C.CE.M.CHP	100pF	50V	
C137	UB052100	C.CE.M.CHP	100pF	50V	

\* New Parts

<b>P. C. B. DSP &amp; P. C. B. OPERATION</b>
--

Schm Ref	PART NO.	Description		
C138	UB245100	C.CE.M.CHP	0.1uF	25V
C139	UB052100	C.CE.M.CHP	100pF	50V
C140	UB052100	C.CE.M.CHP	100pF	50V
C141	UB052100	C.CE.M.CHP	100pF	50V
C150	UB052100	C.CE.M.CHP	100pF	50V
C151	UB012330	C.CE.M.CHP	330pF	50V
C152	UB052100	C.CE.M.CHP	100pF	50V
C153	UB012330	C.CE.M.CHP	330pF	50V
C154	UB052100	C.CE.M.CHP	100pF	50V
C155	UB012330	C.CE.M.CHP	330pF	50V
C156	UB052100	C.CE.M.CHP	100pF	50V
C157	UB052100	C.CE.M.CHP	100pF	50V
C158	UB052100	C.CE.M.CHP	100pF	50V
C159	UB012560	C.CE.M.CHP	560pF	50V
C160	UB052100	C.CE.M.CHP	100pF	50V
C161	UB052100	C.CE.M.CHP	100pF	50V
C162	UB052100	C.CE.M.CHP	100pF	50V
C163	UB052100	C.CE.M.CHP	100pF	50V
C164	UB012330	C.CE.M.CHP	330pF	50V
C165	UB052100	C.CE.M.CHP	100pF	50V
C166	UA952680	C.MYLAR	680pF	50V
C167	UA952680	C.MYLAR	680pF	50V
* C168	UA952150	C.MYLAR	150pF	50V
* C169	UA952150	C.MYLAR	150pF	50V
C170	UB245100	C.CE.M.CHP	0.1uF	25V
C175	UB245100	C.CE.M.CHP	0.1uF	25V
D1	VT332900	DIODE	1SS355	
D2	VT332900	DIODE	1SS355	
D4	VT332900	DIODE	1SS355	
D5	VT332900	DIODE	1SS355	
D6	VT332900	DIODE	1SS355	
D7	VT332900	DIODE	1SS355	
D8	VT332900	DIODE	1SS355	
D9	VT332900	DIODE	1SS355	
D10	VT332900	DIODE	1SS355	
D11	VT332900	DIODE	1SS355	
D12	VT332900	DIODE	1SS355	
D14	VT332900	DIODE	1SS355	
D15	VT332900	DIODE	1SS355	
D16	VT332900	DIODE	1SS355	
D17	VT332900	DIODE	1SS355	
D150	VT332900	DIODE	1SS355	
D151	VT332900	DIODE	1SS355	
D152	VT332900	DIODE	1SS355	
G1	VR463400	TERM.GND	D3.5 TP00385	
G2	VR463400	TERM.GND	D3.5 TP00385	
G3	VR463400	TERM.GND	D3.5 TP00385	
G4	VR463400	TERM.GND	D3.5 TP00385	
IC1	XR038A00	IC	NJM2904M OP AMP	
IC2	XL091A00	IC	HD74HC02FPEL NOR	
* IC3	XW526A00	IC	YSD917	
IC4	XV304B00	IC	YSS918D-F	
* IC5	XV305A00	IC	IS61C1024-20J SRAM	

\* New Parts

Schm Ref	PART NO.	Description		
IC6	XV951A00	IC	AK4526A-VQ	
* IC7	XT955A00	IC	AK4324-VF-E2	
IC8	XF291A00	IC	uPC4570G2	
IC9	XF291A00	IC	uPC4570G2	
IC10	XF291A00	IC	uPC4570G2	
IC11	XF291A00	IC	uPC4570G2	
IC13	XF291A00	IC	uPC4570G2	
IC15	XU965A00	IC	uPC29M33T-E1 3.3V	
Q1	VV655300	TR.DGT	DTA144EKA	
Q2	VV655300	TR.DGT	DTA144EKA	
Q3	VV655300	TR.DGT	DTA144EKA	
Q4	VD303700	TR	2SC3326 A,B	
Q5	VD303700	TR	2SC3326 A,B	
Q6	VD303700	TR	2SC3326 A,B	
Q7	VD303700	TR	2SC3326 A,B	
Q8	VD303700	TR	2SC3326 A,B	
Q9	VD303700	TR	2SC3326 A,B	
Q10	VD303700	TR	2SC3326 A,B	
Q11	VD303700	TR	2SC3326 A,B	
Q12	VD303700	TR	2SC3326 A,B	
Q13	VD303700	TR	2SC3326 A,B	
Q14	VV655700	TR.DGT	DTC144EKA	
R30	HV753220	R.CAR.FP	2.2Ω 1/4W	
R36	HV753220	R.CAR.FP	2.2Ω 1/4W	
R37	HV753220	R.CAR.FP	2.2Ω 1/4W	
R43	HV754100	R.CAR.FP	10Ω 1/4W	
R44	HV754100	R.CAR.FP	10Ω 1/4W	
R45	HV753100	R.CAR.FP	1Ω 1/4W	
R47	HV753100	R.CAR.FP	1Ω 1/4W	
R114	HV753220	R.CAR.FP	2.2Ω 1/4W	
R115	HV753220	R.CAR.FP	2.2Ω 1/4W	
R170	HV753220	R.CAR.FP	2.2Ω 1/4W	
* XL1	V3625700	RSNR.CRYS	24.576MHz	
*	V4800800	P.C.B.	OPERATION(UC)	
*	V4800900	P.C.B.	OPERATION(RT)	
*	V4801000	P.C.B.	OPERATION(AL)	
*	V4801100	P.C.B.	OPERATION(BG)	
* CB501	VU273500	CN	35P	
* CB502	VU270800	CN	8P	
CB503	Vi878800	CN.BS.PIN	10P	
CB581	Vi878700	CN.BS.PIN	9P	
CB621	VQ047100	CN.BS.PIN	7P	
C501	UR866220	C.EL	2.2uF 50V	
C502	VG278900	C.CE.TUBLR	680pF 50V	
C503	VG278900	C.CE.TUBLR	680pF 50V	
C504	UR866100	C.EL	1uF 50V	
C505	VJ599100	C.CE.TUBLR	0.1uF 50V	
C506	UR819100	C.EL	1000uF 6.3V	
C507	UR819100	C.EL	1000uF 6.3V	
C508	VS672200	C.EL	4700uF 5.5V	

\* New Parts

**P. C. B. OPERATION & P. C. B. INPUT**

Schm Ref	PART NO.	Description	
C509	VJ599100	C.CE.TUBLR	0.1uF 50V
C510	UR847100	C.EL	10uF 25V
C511	VJ599100	C.CE.TUBLR	0.1uF 50V
C512	UR847470	C.EL	47uF 25V
C513	VJ599100	C.CE.TUBLR	0.1uF 50V
C514	VJ599100	C.CE.TUBLR	0.1uF 50V
C515	VJ599100	C.CE.TUBLR	0.1uF 50V
C516	VJ599100	C.CE.TUBLR	0.1uF 50V
* C581	VG291300	C.EL	100uF 50V
* C582	VG291300	C.EL	100uF 50V
C583	VG290500	C.EL	1uF 50V
* C584	V5690300	C.PP	47pF 100V
C585	VG290600	C.EL	2.2uF 50V
* C586	V5690300	C.PP	47pF 100V
C587	VG290600	C.EL	2.2uF 50V
C588	VG290500	C.EL	1uF 50V
C589	UU137470	C.EL	47uF 16V
C590	UA655120	C.MYLAR	0.12uF 50V
C591	UA954330	C.MYLAR	0.033uF 50V
C592	UA954330	C.MYLAR	0.033uF 50V
C593	UA655120	C.MYLAR	0.12uF 50V
C594	UU137470	C.EL	47uF 16V
C595	UU137100	C.EL	10uF 16V
C596	VQ645600	C.MYLAR	100pF 50V
C597	VQ645600	C.MYLAR	100pF 50V
C598	UU137100	C.EL	10uF 16V
C599	UU137100	C.EL	10uF 16V
C600	UU137100	C.EL	10uF 16V
C621	VJ599100	C.CE.TUBLR	0.1uF 50V
C622	VJ599100	C.CE.TUBLR	0.1uF 50V
C623	VF466800	C.CE.TUBLR	100pF 50V
C624	VF466800	C.CE.TUBLR	100pF 50V
D501	VD631600	DIODE	1SS133,176,HSS104
D502	VD631600	DIODE	1SS133,176,HSS104
D503	VD631600	DIODE	1SS133,176,HSS104
D504	VD631600	DIODE	1SS133,176,HSS104
D505	VM974100	DIODE.ZENR	HZS5B2TD 5.0V
D506	VM974100	DIODE.ZENR	HZS5B2TD 5.0V
D507	VD631600	DIODE	1SS133,176,HSS104
D508	VM974700	DIODE.ZENR	HZS7B2TD 7.0V
D509	VD631600	DIODE	1SS133,176,HSS104
D510	VD631600	DIODE	1SS133,176,HSS104
D511	VM974400	DIODE.ZENR	HZS6B2TD 6.0V(RT)
D511	VM974600	DIODE.ZENR	HZS7A2TD7V(UCALBG)
D512	VD631600	DIODE	1SS133,176,HSS104
* IC501	XW826A00	IC.CPU	M30217MA-A203FP
IC502	XJ757A00	IC	NJM78L05A-T3
IC581	XA987A00	IC	NJM2068D-D
IC582	XA987A00	IC	NJM2068D-D
JK621	V2589500	CN	1P
PJ621	VR406000	JACK.PIN	3P
PN501	V3750200	PIN	L=70
Q501	iA093320	TR	2SA933S Q,R

\* New Parts

Schm Ref	PART NO.	Description	
Q502	iA093320	TR	2SA933S Q,R
Q503	VG722000	TR.DGT	DTC144ES
Q504	iA093320	TR	2SA933S Q,R
Q505	VR948600	TR	2SC4038 Q,R,S
Q506	VR948600	TR	2SC4038 Q,R,S
R581	VP939800	R.MTL.OXD	10Ω 1W(UCRT)
R581	VP940200	R.MTL.OXD	47Ω 1W(ALBG)
R582	VP939800	R.MTL.OXD	10Ω 1W(UCRT)
R582	VP940200	R.MTL.OXD	47Ω 1W(ALBG)
ST601	BB071360	SCR.TERM	8.3x13
SW501	V4586200	SW.RT.ENC	REB161PVB20F
SW502	VG392900	SW.TACT	SKHVAA
SW503	VG392900	SW.TACT	SKHVAA
SW504	VG392900	SW.TACT	SKHVAA
SW505	VG392900	SW.TACT	SKHVAA
SW506	VG392900	SW.TACT	SKHVAA
SW507	VG392900	SW.TACT	SKHVAA
SW508	VG392900	SW.TACT	SKHVAA
SW509	VG392900	SW.TACT	SKHVAA
SW510	VG392900	SW.TACT	SKHVAA
SW511	VG392900	SW.TACT	SKHVAA
SW512	VG392900	SW.TACT	SKHVAA
SW513	VG392900	SW.TACT	SKHVAA(BG)
SW514	VG392900	SW.TACT	SKHVAA(BG)
SW515	VG392900	SW.TACT	SKHVAA
SW516	VG392900	SW.TACT	SKHVAA
SW517	VG392900	SW.TACT	SKHVAA(BG)
SW518	VG392900	SW.TACT	SKHVAA(BG)
U501	V3872300	L.DTCT	PIC-28143TH5
V501	V4193300	FL.DSPLY	16-BT-71GK
VR581	VP741800	VR	B20KΩ
VR582	VP741900	VR	G25KΩ
VR583	VP742000	VR	MN100KΩ
XL501	V4610100	RSNR.CE	10MHz
	VS588900	SHEET	
	V4186900	SPACER	FL-WIDE
*	V4800300	P.C.B.	INPUT(UCRT)
*	V4800400	P.C.B.	INPUT(ABGL)
CB102	VM923600	CN.BS.PIN	13P
CB103	Vi878900	CN.BS.PIN	11P
* CB104	VQ048400	CN	35P
CB105	VM689000	CN.BS.PIN	23P
CB106	VQ047400	CN.BS.PIN	19P
CB107	VQ963700	CN.BS.PIN	16P
CB108	VK025300	CN.BS.PIN	9P
CB110	VQ047500	CN.BS.PIN	20P
CB112	Vi878900	CN.BS.PIN	11P
CB301	Vi878800	CN.BS.PIN	10P
CB302	VK027000	CN.BS.PIN	11P

\* New Parts

<b>P. C. B. INPUT</b>
-----------------------

Schm Ref	PART NO.	Description			
CB303	VQ047100	CN.BS.PIN	7P		
CB331	Vi878900	CN.BS.PIN	11P		
CB351	Vi878800	CN.BS.PIN	10P		
* CB371	V5478200	CN.PHOT.SN	1P GP1FA551RZ		
* CB372	V5478200	CN.PHOT.SN	1P GP1FA551RZ		
* CB373	V5478200	CN.PHOT.SN	1P GP1FA551RZ		
* CB374	VQ044300	CN.BS.PIN	7P		
C102	UA952100	C.MYLAR	100pF	50V(ABGL)	
C103	UA952220	C.MYLAR	220pF	50V	
C104	UA952100	C.MYLAR	100pF	50V(ABGL)	
C105	UA952220	C.MYLAR	220pF	50V	
C107	VF467300	C.CE.TUBLR	0.01uF	16V	
C108	VK533900	C.PP	100pF	200V	
C109	VK533900	C.PP	100pF	200V	
C112	UA952100	C.MYLAR	100pF	50V	
C113	UA952100	C.MYLAR	100pF	50V	
C114	FG651470	C.CE	47pF	50V	
C115	FG651470	C.CE	47pF	50V	
C116	UA952100	C.MYLAR	100pF	50V	
C117	UA952100	C.MYLAR	100pF	50V	
C118	UA952100	C.MYLAR	100pF	50V	
C119	UA952100	C.MYLAR	100pF	50V	
C120	VF466800	C.CE.TUBLR	100pF	50V	
C121	VF466800	C.CE.TUBLR	100pF	50V	
C122	VF466700	C.CE.TUBLR	47pF	50V	
C123	VF466700	C.CE.TUBLR	47pF	50V	
C124	UA655220	C.MYLAR	0.22uF	50V	
C125	VF467300	C.CE.TUBLR	0.01uF	16V	
C126	UR866220	C.EL	2.2uF	50V	
C127	UR828220	C.EL	220uF	10V	
* C128	V4578900	C.EL	47uF	35V	
C129	UA953100	C.MYLAR	1000pF	50V	
C130	UA653910	C.MYLAR	9100pF	50V	
C131	UA954330	C.MYLAR	0.033uF	50V	
C132	UA653910	C.MYLAR	9100pF	50V	
C133	UA954330	C.MYLAR	0.033uF	50V	
C134	UA953100	C.MYLAR	1000pF	50V	
C135	UR828220	C.EL	220uF	10V	
* C136	V4578900	C.EL	47uF	35V	
C137	UR866220	C.EL	2.2uF	50V	
C138	VG291200	C.EL	47uF	50V	
C139	VG291200	C.EL	47uF	50V	
C140	VG287200	C.EL	10uF	50V	
C141	VG287200	C.EL	10uF	50V	
C142	VJ599100	C.CE.TUBLR	0.1uF	50V	
C143	VJ599100	C.CE.TUBLR	0.1uF	50V	
C144	UA954680	C.MYLAR	0.068uF	50V	
C145	UA954180	C.MYLAR	0.018uF	50V	
C146	UR828220	C.EL	220uF	10V	
C147	UU137100	C.EL	10uF	16V	
C148	UU137100	C.EL	10uF	16V	
C149	UU137100	C.EL	10uF	16V	
C150	UU137100	C.EL	10uF	16V	

\* New Parts

Schm Ref	PART NO.	Description			
C151	VG287200	C.EL	10uF	50V	
C152	VG288500	C.EL	10uF	50V	
C153	VG287200	C.EL	10uF	50V	
C154	UA952220	C.MYLAR	220pF	50V	
C155	UA952100	C.MYLAR	100pF	50V	
C156	VG287200	C.EL	10uF	50V	
C157	VG288500	C.EL	10uF	50V	
C158	VG287200	C.EL	10uF	50V	
C159	UR837100	C.EL	10uF	16V	
C160	UR837100	C.EL	10uF	16V	
C161	VJ599100	C.CE.TUBLR	0.1uF	50V	
C162	VJ599100	C.CE.TUBLR	0.1uF	50V	
C163	UA952390	C.MYLAR	390pF	50V	
C164	UA952390	C.MYLAR	390pF	50V	
* C165	Vi717200	C.MYLAR	0.027uF	50V	
* C166	Vi717200	C.MYLAR	0.027uF	50V	
C167	UU137100	C.EL	10uF	16V	
C168	UU137100	C.EL	10uF	16V	
* C169	VP917700	C.PP	470pF	100V	
* C170	V4578900	C.EL	47uF	35V	
* C171	V4578900	C.EL	47uF	35V	
* C172	VP917700	C.PP	470pF	100V	
C173	UU137100	C.EL	10uF	16V	
C174	UU137100	C.EL	10uF	16V	
* C175	Vi717200	C.MYLAR	0.027uF	50V	
* C176	Vi717200	C.MYLAR	0.027uF	50V	
C177	VJ599100	C.CE.TUBLR	0.1uF	50V	
C178	VJ599100	C.CE.TUBLR	0.1uF	50V	
C179	VG291200	C.EL	47uF	50V	
C180	VG291200	C.EL	47uF	50V	
C181	VJ599100	C.CE.TUBLR	0.1uF	50V	
C182	VG287200	C.EL	10uF	50V	
C183	VG291200	C.EL	47uF	50V	
C184	VG291200	C.EL	47uF	50V	
C185	VG287200	C.EL	10uF	50V	
C186	UR866470	C.EL	4.7uF	50V	
C187	UR866470	C.EL	4.7uF	50V	
C188	VJ599100	C.CE.TUBLR	0.1uF	50V	
C189	VJ599100	C.CE.TUBLR	0.1uF	50V	
C190	VG287200	C.EL	10uF	50V	
C191	VG287200	C.EL	10uF	50V	
C192	UR866470	C.EL	4.7uF	50V	
C193	VF466800	C.CE.TUBLR	100pF	50V	
C194	VF467000	C.CE.TUBLR	1000pF	50V	
C195	VF467300	C.CE.TUBLR	0.01uF	16V	
C196	VJ599100	C.CE.TUBLR	0.1uF	50V	
C197	VF467000	C.CE.TUBLR	1000pF	50V	
C198	VF466800	C.CE.TUBLR	100pF	50V	
C199	UR866470	C.EL	4.7uF	50V	
C200	VJ599100	C.CE.TUBLR	0.1uF	50V	
C201	VJ599100	C.CE.TUBLR	0.1uF	50V	
C202	UA952100	C.MYLAR	100pF	50V	
C203	UA952100	C.MYLAR	100pF	50V	

\* New Parts



<b>P. C. B. INPUT</b>
-----------------------

Schm Ref	PART NO.	Description		
C302	VF466800	C.CE.TUBLR	100pF	50V
C303	UR837470	C.EL	47uF	16V
C304	UR837100	C.EL	10uF	16V
C305	UR837100	C.EL	10uF	16V
C306	UR837100	C.EL	10uF	16V
C307	UR837100	C.EL	10uF	16V
C309	VF466800	C.CE.TUBLR	100pF	50V
C310	UR837470	C.EL	47uF	16V
C331	VG278400	C.CE.TUBLR	220pF	50V
C332	VG278400	C.CE.TUBLR	220pF	50V
C333	VG278400	C.CE.TUBLR	220pF	50V
C334	VG278400	C.CE.TUBLR	220pF	50V
C335	VG278400	C.CE.TUBLR	220pF	50V
C336	VG278400	C.CE.TUBLR	220pF	50V
C337	VF467300	C.CE.TUBLR	0.01uF	16V
C351	VF466800	C.CE.TUBLR	100pF	50V
C352	VF466800	C.CE.TUBLR	100pF	50V
C353	UR837100	C.EL	10uF	16V
C354	UR837100	C.EL	10uF	16V
C355	UR837100	C.EL	10uF	16V
C356	UR837100	C.EL	10uF	16V
C357	VF466800	C.CE.TUBLR	100pF	50V
C358	VF466800	C.CE.TUBLR	100pF	50V
C360	UR837330	C.EL	33uF	16V
C362	UR837330	C.EL	33uF	16V
C363	UR837470	C.EL	47uF	16V
C364	UR837470	C.EL	47uF	16V
C365	UR837100	C.EL	10uF	16V
C366	UR837100	C.EL	10uF	16V
C367	UR837100	C.EL	10uF	16V
C368	UR837100	C.EL	10uF	16V
C371	VJ599100	C.CE.TUBLR	0.1uF	50V
C372	VJ599100	C.CE.TUBLR	0.1uF	50V
C373	UR847220	C.EL	22uF	25V
C374	VG276600	C.CE.TUBLR	22pF	50V
C375	VF466600	C.CE.TUBLR	10pF	50V
C376	VF466600	C.CE.TUBLR	10pF	50V
C377	VG276600	C.CE.TUBLR	22pF	50V
C378	UR847220	C.EL	22uF	25V
C379	VJ599100	C.CE.TUBLR	0.1uF	50V
C380	VJ599100	C.CE.TUBLR	0.1uF	50V
C381	VJ599100	C.CE.TUBLR	0.1uF	50V
C382	VJ599100	C.CE.TUBLR	0.1uF	50V
C383	VJ599100	C.CE.TUBLR	0.1uF	50V
C384	VG278400	C.CE.TUBLR	220pF	50V
C385	VF467000	C.CE.TUBLR	1000pF	50V
C386	VF467000	C.CE.TUBLR	1000pF	50V
C387	VG278400	C.CE.TUBLR	220pF	50V
C388	VJ599100	C.CE.TUBLR	0.1uF	50V
C389	VJ599100	C.CE.TUBLR	0.1uF	50V
C390	VJ599100	C.CE.TUBLR	0.1uF	50V
C391	UR828100	C.EL	100uF	10V
D101	VM975300	DIODE.ZENR	HZS11B2TD 11V	

\* New Parts

Schm Ref	PART NO.	Description	
D102	VM975300	DIODE.ZENR	HZS11B2TD 11V
D103	VM975300	DIODE.ZENR	HZS11B2TD 11V
D104	VM975300	DIODE.ZENR	HZS11B2TD 11V
D371	VD631600	DIODE	1SS133,176,HSS104
D372	VD631600	DIODE	1SS133,176,HSS104
D373	VD631600	DIODE	1SS133,176,HSS104
D374	VD631600	DIODE	1SS133,176,HSS104
* IC101	XP580A00	IC	TC9273N-004
IC102	XP896A00	IC	LC78213
IC103	XP895A00	IC	LC78212
IC104	XM356A00	IC	NJM2068LD
IC105	XM356A00	IC	NJM2068LD
IC106	XM356A00	IC	NJM2068LD
IC107	XP265A00	IC	BU2090
IC108	iG092000	IC	M5220L
IC109	iG092000	IC	M5220L
IC110	iG092000	IC	M5220L
IC111	XR040A00	IC	TC9299P
IC112	XA987A00	IC	NJM2068D-D
IC113	XR040A00	IC	TC9299P
IC114	XA987A00	IC	NJM2068D-D
* IC301	XW164A00	IC	NJM2296D
* IC351	XW164A00	IC	NJM2296D
* IC352	XW164A00	IC	NJM2296D
IC371	iG142200	IC	TC74HCU04AP
IC372	iG142200	IC	TC74HCU04AP
* IC373	iR000000	IC	TC74HC00AP
* IC374	iR000000	IC	TC74HC00AP
IC395	XT208A00	IC	HD74HC153P MPX
JK351	VP113600	CN.DIN	2P
JK352	VP113600	CN.DIN	2P
JK353	VP113600	CN.DIN	2P
L371	GE901970	COIL	68uH
L372	GE901970	COIL	68uH
L373	GE901970	COIL	68uH
PJ101	VQ260900	JACK.PIN	4P
PJ102	VJ696300	JACK.PIN	4P
PJ103	VU857800	JACK.PIN	6P
PJ104	VJ696300	JACK.PIN	4P
PJ105	VK437600	JACK.PIN	1P
PJ301	VJ695900	JACK.PIN	3P
PJ302	VJ695900	JACK.PIN	3P
PJ331	VT003300	JACK.PIN	6P
PJ371	VZ537500	JACK.PIN	2P
PN101	V3750200	PIN	L=70
Q102	iC287820	TR	2SC2878 A,B
Q106	iC287820	TR	2SC2878 A,B
Q107	iC287820	TR	2SC2878 A,B
Q110	iC287820	TR	2SC2878 A,B
Q112	iC287820	TR	2SC2878 A,B
Q114	iC287820	TR	2SC2878 A,B
Q119	iC287820	TR	2SC2878 A,B
Q120	iC287820	TR	2SC2878 A,B

\* New Parts

<b>P. C. B. INPUT &amp; P. C. B. POWER</b>
--

Schm Ref	PART NO.	Description	
Q121	VG721700	TR.DGT	DTA144ES
Q124	VG721700	TR.DGT	DTA144ES
Q125	VG721700	TR.DGT	DTA144ES
R141	HV755100	R.CAR.FP	100Ω 1/4W
R154	HV755100	R.CAR.FP	100Ω 1/4W
R155	HV753220	R.CAR.FP	2.2Ω 1/4W(UCRT)
R155	VP940200	R.MTL.OXD	47Ω 1W(ABGL)
R156	HV753220	R.CAR.FP	2.2Ω 1/4W(UCRT)
R156	VP940200	R.MTL.OXD	47Ω 1W(ABGL)
R216	HV753220	R.CAR.FP	2.2Ω 1/4W(UCRT)
R216	VP940200	R.MTL.OXD	47Ω 1W(ABGL)
R217	HV753220	R.CAR.FP	2.2Ω 1/4W(UCRT)
R217	VP940200	R.MTL.OXD	47Ω 1W(ABGL)
R222	HV753220	R.CAR.FP	2.2Ω 1/4W
R231	HV753220	R.CAR.FP	2.2Ω 1/4W(UCRT)
R231	VP940200	R.MTL.OXD	47Ω 1W(ABGL)
R232	HV753220	R.CAR.FP	2.2Ω 1/4W(UCRT)
R232	VP940200	R.MTL.OXD	47Ω 1W(ABGL)
R245	HV753220	R.CAR.FP	2.2Ω 1/4W
R246	HV753220	R.CAR.FP	2.2Ω 1/4W
R386	HV753220	R.CAR.FP	2.2Ω 1/4W
*	V4801600	P.C.B.	POWER(UC)
*	V4801700	P.C.B.	POWER(RT)
*	V4801800	P.C.B.	POWER(A)
*	V4801900	P.C.B.	POWER(B)
*	V4802000	P.C.B.	POWER(GL)
CB401	VQ045300	CN.BS.PIN	23P
CB451	Vi878600	CN.BS.PIN	8P
CB721	VQ963000	CN.BS.PIN	9P
CB722	Vi878600	CN.BS.PIN	8P
CB801	VQ960900	CN.BS.PIN	6P
CB802	VP206500	HOLDER.FUS	EYF-52BCT(GL)
CB803	VP206500	HOLDER.FUS	EYF-52BCT(GL)
CB804	VP206500	HOLDER.FUS	EYF-52BCT
CB805	VG879900	CN.BS.PIN	2P
CB806	VP206500	HOLDER.FUS	EYF-52BCT
CB851	VP206500	HOLDER.FUS	EYF-52BCT(RT)
CB852	VP206500	HOLDER.FUS	EYF-52BCT(RT)
C401	VG290600	C.EL	2.2uF 50V
* C402	VP917500	C.PP	100pF 100V
* C403	VP917500	C.PP	100pF 100V
C404	VG290600	C.EL	2.2uF 50V
C405	VG290600	C.EL	2.2uF 50V
C406	VG290600	C.EL	2.2uF 50V
C407	VG290600	C.EL	2.2uF 50V
C408	VG290600	C.EL	2.2uF 50V
C409	UN866100	C.EL	1uF 50V
C410	UU137100	C.EL	10uF 16V
C411	VG277000	C.CE.TUBLR	33pF 50V(BGL)
C412	VM645200	C.PP	560pF 100V

\* New Parts

Schm Ref	PART NO.	Description	
C414	VM645200	C.PP	560pF 100V
C416	VG277000	C.CE.TUBLR	33pF 50V(BGL)
C417	UU137100	C.EL	10uF 16V
C418	UU137100	C.EL	10uF 16V
C419	VG277000	C.CE.TUBLR	33pF 50V(BGL)
* C420	VG291300	C.EL	100uF 50V
* C421	VP917500	C.PP	100pF 100V
C422	VG286200	C.EL	100uF 10V
C423	UA952100	C.MYLAR	100pF 50V
C424	VG286200	C.EL	100uF 10V
* C425	VG291300	C.EL	100uF 50V
C426	VG277000	C.CE.TUBLR	33pF 50V(BGL)
* C427	Vi578700	C.EL	10uF 50V
* C428	Vi578700	C.EL	10uF 50V
C429	VG277000	C.CE.TUBLR	33pF 50V(BGL)
C430	UA952100	C.MYLAR	100pF 50V
C431	VG286200	C.EL	100uF 10V
C432	UA952100	C.MYLAR	100pF 50V
C433	VG286200	C.EL	100uF 10V
C434	VG277000	C.CE.TUBLR	33pF 50V(BGL)
* C435	Vi578700	C.EL	10uF 50V
C436	VJ599100	C.CE.TUBLR	0.1uF 50V
* C451	VG291500	C.EL	330uF 50V
* C452	VG291500	C.EL	330uF 50V
△ C453	UR749470	C.EL	4700uF 25V
C454	VE326000	C.MYLAR.ML	0.1uF 50V
△ C455	UR749470	C.EL	4700uF 25V
C456	VE326000	C.MYLAR.ML	0.1uF 50V
C457	VS745400	C.POL.MTL	0.1uF 100V
△ C458	UR739470	C.EL	4700uF 16V(UC)
△ C458	UR73A100	C.EL	10000uF 16V(RTABGL)
C461	VE326000	C.MYLAR.ML	0.1uF 50V
C462	VE326000	C.MYLAR.ML	0.1uF 50V
△ C463	UR739470	C.EL	4700uF 16V(UC)
△ C463	UR73A100	C.EL	10000uF 16V(RTABGL)
C464	VS745400	C.POL.MTL	0.1uF 100V
C721	VG291200	C.EL	47uF 50V
C722	VG291200	C.EL	47uF 50V
C723	VG287600	C.EL	100uF 25V
C724	VG288500	C.EL	10uF 50V
C725	VG287600	C.EL	100uF 25V
C726	VG288500	C.EL	10uF 50V
C727	VG291200	C.EL	47uF 50V
C728	VG291200	C.EL	47uF 50V
C729	UR838100	C.EL	100uF 16V
C730	UR838100	C.EL	100uF 16V
C731	UR847100	C.EL	10uF 25V
C732	UR838100	C.EL	100uF 16V
C733	UR847100	C.EL	10uF 25V
C734	UR847100	C.EL	10uF 25V
C801	FG613100	C.CE	1000pF 50V(RT)
C802	VJ599100	C.CE.TUBLR	0.1uF 50V
C803	UR749100	C.EL	1000uF 25V(UCABGL)

\* New Parts

**P. C. B. POWER & P. C. B. MAIN**

Schm Ref	PART NO.	Description	
* C804	VL884600	C.PP	0.01uF 100V
* C805	UR896470	C.EL	4.7uF 100V(RT)
C806	Vi716700	C.MYLAR	0.01uF 50V
△ C807	V3501400	C.CE.SAFTY	0.01uP 275V
C808	UR848220	C.EL	220uF 25V(RT)
D401	VM974200	DIODE.ZENR	HZS5C2TD 5.0V
△ D451	VQ379300	DIODE.BRG	S1VB20 1.0A 200V
△ D452	VQ379300	DIODE.BRG	S1VB20 1.0A 200V
△ * D453	V4269600	DIODE.BRG	D2SBA20 1.5A 200V
D721	VM976300	DIODE.ZENR	HZS242TD 24V
D722	VM976300	DIODE.ZENR	HZS242TD 24V
D801	VD631600	DIODE	1SS133,176,HSS104
D803	VM975600	DIODE.ZENR	HZS12B2TD 12V(RT)
D804	VV307700	DIODE	1N4002S
D805	VV307700	DIODE	1N4002S
D806	VV307700	DIODE	1N4002S
D807	VV307700	DIODE	1N4002S
△ F801	VT942900	FUSE	TH2.5A 250V(GL)
△ F802	KB000790	FUSE	T4.0A 250V(ABGL)
△ F802	VS823300	FUSE	T8.0A 125V(UCRT)
△ F851	KB000790	FUSE	T4.0A 250V(RT)
HS801	VR506800	HEAT.SINK	PUH16-25(RT)
IC401	XA987A00	IC	NJM2068D-D
IC402	XA987A00	IC	NJM2068D-D
IC403	XA987A00	IC	NJM2068D-D
IC404	XF494A00	IC	LB1641
△ IC721	XJ608A00	IC	NJM7812FA
△ IC722	XD343A00	IC	NJM79M12FA
△ IC723	XJ604A00	IC	NJM78M05FA
△ IC724	XE436A00	IC	NJM79M05FA
△ IC725	XJ607A00	IC	NJM7805FA 5V
Q721	iC181510	TR	2SC1815 Y
Q722	iA101510	TR	2SA1015 Y
Q801	iC174020	TR	2SC1740S R,S
Q802	VR510800	TR	2SD2396 J,K(RT)
R411	VP940200	R.MTL.OXD	47Ω 1W
R412	VP940200	R.MTL.OXD	47Ω 1W
R435	HV754100	R.CAR.FP	10Ω 1/4W
R451	HV753100	R.CAR.FP	1Ω 1/4W
R452	HV753100	R.CAR.FP	1Ω 1/4W
R725	HV753100	R.CAR.FP	1Ω 1/4W
R726	HV753100	R.CAR.FP	1Ω 1/4W
R727	HV755100	R.CAR.FP	100Ω 1/4W
R728	HV755100	R.CAR.FP	100Ω 1/4W
R729	HV753100	R.CAR.FP	1Ω 1/4W
* R730	VP939500	R.MTL.FLM	1Ω 1W
R731	VP939600	R.MTL.FLM	2.2Ω 1W
R802	HV756560	R.CAR.FP	5.6KΩ 1/4W(RT)
R803	HV756560	R.CAR.FP	5.6KΩ 1/4W(RT)
RY801	V2712300	RELAY	DC SDT-S-112LMR
△ ST801	BB071360	SCR.TERM	8.3x13
SW851	VA961800	VOLT.SELCT	ESE-37247-F(RT)
△ * T801	XW606A00	TRANS.PWR	(UC)

\* New Parts

Schm Ref	PART NO.	Description	
△ * T801	XW607A00	TRANS.PWR	(RT)
△ * T801	XW608A00	TRANS.PWR	(ABGL)
△ * TE801	V4746400	OUTLET.AC	S2-764T-214C(RT)
△ TE801	VT915000	OUTLET.AC	2P(A)
△ TE801	VU543100	OUTLET.AC	2P(UC)
△ TE801	VU543300	OUTLET.AC	1P(B)
△ TE801	VU543400	OUTLET.AC	2P(GL)
VR401	VV613500	VR	A100KΩ
	EP600140	SCR.BND.HD	3x10 MFZN2-BL(RT)
*	V4802500	P.C.B.	MAIN(U)
*	V4802600	P.C.B.	MAIN(C)
*	V4802700	P.C.B.	MAIN(RAT)
*	V4802800	P.C.B.	MAIN(BGL)
CB501	VQ045000	CN.BS.PIN	20P
CB502	VQ961700	CN.BS.PIN	14P
CB503	VQ963500	CN.BS.PIN	14P
CB505	VF728200	CN.BS.PIN	10P
CB506	Vi878600	CN.BS.PIN	8P
CB507	VQ961200	CN.BS.PIN	9P
CB702	VQ584700	CN.BS.PIN	5P
CB711	VQ584700	CN.BS.PIN	5P
CB751	Vi878600	CN.BS.PIN	8P
CB752	VQ962700	CN.BS.PIN	6P
* CB763	VQ585200	CN.BS.PIN	10P(UC)
* CB764	VQ585200	CN.BS.PIN	10P(UC)
C501	VK534000	C.PP	220pF 200V
* C502	Vi377400	C.EL	4.7uF 63V
* C503	V2290000	C.EL	22uF 63V
C504	UU137100	C.EL	10uF 16V
C505	UU137100	C.EL	10uF 16V
* C506	V5618600	C.EL	10uF 25V
C507	UU138100	C.EL	100uF 16V
* C508	Vi578700	C.EL	10uF 50V
* C509	Vi578700	C.EL	10uF 50V
C510	VQ645600	C.MYLAR	100pF 50V
C511	VQ462600	C.MYLAR	220pF 50V
C512	VQ645600	C.MYLAR	100pF 50V
C513	VQ462600	C.MYLAR	220pF 50V
C514	VQ645600	C.MYLAR	100pF 50V
C515	VQ462600	C.MYLAR	220pF 50V
C516	UA952100	C.MYLAR	100pF 50V
C517	UA952220	C.MYLAR	220pF 50V
C518	UA952100	C.MYLAR	100pF 50V
C519	UA952220	C.MYLAR	220pF 50V
C520	FU451150	C.MICA	15pF 500V
* C521	VG291300	C.EL	100uF 50V
* C522	VP918000	C.PP	3300pF 100V
C523	FU451150	C.MICA	15pF 500V
* C524	VG291300	C.EL	100uF 50V
C525	VP918000	C.PP	3300pF 100V

\* New Parts

## P. C. B. MAIN

Schm Ref	PART NO.	Description		
* C526	FU451150	C.MICA	15pF	500V
C527	VG291200	C.EL	47uF	50V
* C528	VP918000	C.PP	3300pF	100V
C529	VR516400	C.CE	15pF	500V
* C530	V4578900	C.EL	47uF	35V
C531	UA953330	C.MYLAR	3300pF	50V
C532	VR516400	C.CE	15pF	500V
* C533	V4578900	C.EL	47uF	35V
C534	UA953330	C.MYLAR	3300pF	50V
C535	VG291200	C.EL	47uF	50V
C536	VG291200	C.EL	47uF	50V
C537	VG291200	C.EL	47uF	50V
C538	VG291200	C.EL	47uF	50V
C539	VG291200	C.EL	47uF	50V
* C540	V2290000	C.EL	22uF	63V
C541	VS759000	C.PP	150pF	630V
C542	VG287500	C.EL	47uF	50V
* C543	V5618900	C.EL	47uF	25V
C544	VS759000	C.PP	150pF	630V
C545	VS759000	C.PP	150pF	630V
* C546	VT898000	C.MYLAR	0.1uF	100V
* C547	V5618900	C.EL	47uF	25V
C548	VS759000	C.PP	150pF	630V
C549	VS759000	C.PP	150pF	630V
* C550	V5618900	C.EL	47uF	25V
C551	VS759000	C.PP	150pF	630V
* C552	V3872800	C.MYLAR	150pF	100V
C553	VG287500	C.EL	47uF	50V
* C554	V3872800	C.MYLAR	150pF	100V
* C555	V3872800	C.MYLAR	150pF	100V
C556	VG287500	C.EL	47uF	50V
* C557	V3872800	C.MYLAR	150pF	100V
* C558	VP918300	C.PP	0.022uF	100V
* C559	VP918300	C.PP	0.022uF	100V
* C560	VP918300	C.PP	0.022uF	100V
C561	UA954220	C.MYLAR	0.022uF	50V
C562	UA954220	C.MYLAR	0.022uF	50V
C563	UR866470	C.EL	4.7uF	50V
* C564	VT898000	C.MYLAR	0.1uF	100V
C565	VK534000	C.PP	220pF	200V
C568	UR866470	C.EL	4.7uF	50V
C569	UR866470	C.EL	4.7uF	50V
C570	UR818220	C.EL	220uF	6.3V
C573	VF466900	C.CE.TUBLR	470pF	50V(RATBGL)
C574	VF466900	C.CE.TUBLR	470pF	50V(RATBGL)
C575	VF466900	C.CE.TUBLR	470pF	50V(RATBGL)
C576	VF466900	C.CE.TUBLR	470pF	50V(RATBGL)
C577	UA954100	C.MYLAR	0.01uF	50V(RATBGL)
C578	UA954100	C.MYLAR	0.01uF	50V(RATBGL)
C579	UA954100	C.MYLAR	0.01uF	50V(RATBGL)
C580	UA954100	C.MYLAR	0.01uF	50V(RATBGL)
C581	UA954100	C.MYLAR	0.01uF	50V(RATBGL)
* C582	V2290000	C.EL	22uF	63V

\* New Parts

Schm Ref	PART NO.	Description		
C583	UA954100	C.MYLAR	0.01uF	50V(RATBGL)
C584	UA954100	C.MYLAR	0.01uF	50V(RATBGL)
C585	UA954100	C.MYLAR	0.01uF	50V(RATBGL)
C586	UA954100	C.MYLAR	0.01uF	50V(RATBGL)
C701	VF466900	C.CE.TUBLR	470pF	50V(RATBGL)
C702	VF466900	C.CE.TUBLR	470pF	50V(RATBGL)
* C703	Vi716300	C.MYLAR	4700pF	50V(RATBGL)
* C704	Vi716300	C.MYLAR	4700pF	50V(RATBGL)
* C705	Vi716300	C.MYLAR	4700pF	50V(RATBGL)
* C706	Vi716300	C.MYLAR	4700pF	50V(RATBGL)
C707	Vi716700	C.MYLAR	0.01uF	50V(RATBGL)
C708	Vi716700	C.MYLAR	0.01uF	50V(RATBGL)
C711	UA954100	C.MYLAR	0.01uF	50V(RATBGL)
C712	UA954100	C.MYLAR	0.01uF	50V(RATBGL)
C713	Vi716700	C.MYLAR	0.01uF	50V(RATBGL)
△ C751	V2922200	C.EL	12000uF	63V(UC)
△ C751	VS529200	C.EL	10000uF	63V(RATBGL)
△ C752	V2922200	C.EL	12000uF	63V(UC)
△ C752	VS529200	C.EL	10000uF	63V(RATBGL)
* C753	VT898000	C.MYLAR	0.1uF	100V
* C754	VT898000	C.MYLAR	0.1uF	100V
C755	VK534100	C.PP	0.01uF	100V
* C760	VG291300	C.EL	100uF	50V
* C761	VG291300	C.EL	100uF	50V
C762	UA655100	C.MYLAR	0.1uF	50V
C763	UA655100	C.MYLAR	0.1uF	50V
C764	Vi716700	C.MYLAR	0.01uF	50V(RATBGL)
C765	Vi716700	C.MYLAR	0.01uF	50V(RATBGL)
* D501	VG440300	DIODE.ZENR	MTZJ12C	12V(RATBGL)
* D501	VG440700	DIODE.ZENR	MTZJ15A	15V(C)
* D501	VG441000	DIODE.ZENR	MTZJ16A	16V(U)
D502	VD631600	DIODE	1SS133,176,HSS104	
D503	VD631600	DIODE	1SS133,176,HSS104	
D504	VD631600	DIODE	1SS133,176,HSS104	
D505	VD631600	DIODE	1SS133,176,HSS104	
* D506	VG438800	DIODE.ZENR	MTZJ8.2A8.2V	(RATBGL)
D506	VG439600	DIODE.ZENR	MTZJ10C	10V(UC)
D507	VN008700	DIODE	1SS270A	
D508	VN008700	DIODE	1SS270A	
D509	VN008700	DIODE	1SS270A	
D510	VN008700	DIODE	1SS270A	
D511	VN008700	DIODE	1SS270A	
* D512	VG440300	DIODE.ZENR	MTZJ12C	12V
* D513	VG443200	DIODE.ZENR	MTZ J 30.0A	30.0V
* D514	VG440300	DIODE.ZENR	MTZJ12C	12V
* D515	VG440300	DIODE.ZENR	MTZJ12C	12V
D521	VD631600	DIODE	1SS133,176,HSS104	
D522	VN008700	DIODE	1SS270A	
D523	VN008700	DIODE	1SS270A	
D524	VN008700	DIODE	1SS270A	
D525	VN008700	DIODE	1SS270A	
D526	VN008700	DIODE	1SS270A	
* D527	VG440300	DIODE.ZENR	MTZJ12C	12V

\* New Parts

## P. C. B. MAIN

Schm Ref	PART NO.	Description		Schm Ref	PART NO.	Description	
* D528	VG440300	DIODE.ZENR	MTZJ12C 12V	△ * Q530	V4096100	TR	2SC4614 S,T(UC)
* D529	VG440300	DIODE.ZENR	MTZJ12C 12V	△ Q530	VP872700	TR	2SC4488 ST(RATBGL)
* D530	VG440300	DIODE.ZENR	MTZJ12C 12V	△ Q531	VR355900	TR.PAIR	2SA1695/C4468 OPY
D531	VD631600	DIODE	1SS133,176,HSS104	△ Q532	VS883300	TR	2SB1565 E,F
D532	VD631600	DIODE	1SS133,176,HSS104	△ * Q533	V4096000	TR	2SA1770 S,T(UC)
△ * D751	VM702000	DIODE.BRG	S5VB20 3.5A 200V	△ Q533	VP872600	TR	2SA1708 ST(RATBGL)
* D752	VG440300	DIODE.ZENR	MTZJ12C 12V	△ * Q534	V4096100	TR	2SC4614 S,T(UC)
△ D759	VS997800	DIODE	1T2	△ Q534	VP872700	TR	2SC4488 ST(RATBGL)
△ D760	VS997800	DIODE	1T2	△ Q535	VR355900	TR.PAIR	2SA1695/C4468 OPY
D761	VN008700	DIODE	1SS270A	△ Q536	VP883000	TR	2SA893A D,E
△ D762	VS997800	DIODE	1T2	△ * Q537	V4096000	TR	2SA1770 S,T(UC)
△ D763	VS997800	DIODE	1T2	△ Q537	VP872600	TR	2SA1708 ST(RATBGL)
D764	VN008700	DIODE	1SS270A	△ * Q538	V4096100	TR	2SC4614 S,T(UC)
D765	VN008700	DIODE	1SS270A	△ Q538	VP872700	TR	2SC4488 ST(RATBGL)
D766	VG437200	DIODE.ZENR	MTZJ4.7C 4.7V	△ Q539	VR355900	TR.PAIR	2SA1695/C4468 OPY
D767	VN008700	DIODE	1SS270A	Q540	VP883000	TR	2SA893A D,E
D768	VN008700	DIODE	1SS270A	△ * Q541	V4096000	TR	2SA1770 S,T(UC)
G501	VR463400	TERM.GND	D3.5 TP00385	△ Q541	VP872600	TR	2SA1708 ST(RATBGL)
JK711	V2700900	JACK.PHONE	JY-6317-03-030GD	△ * Q542	V4096100	TR	2SC4614 S,T(UC)
* PJ501	V5479200	JACK.PIN	4P YKC21-3739	△ Q542	VP872700	TR	2SC4488 ST(RATBGL)
PJ701	VR765100	JACK.PIN	2P	△ Q543	VR355900	TR.PAIR	2SA1695/C4468 OPY
PN501	V3750200	PIN	L=70	Q544	VP883100	TR	2SC1890A D,E
PN502	V3750200	PIN	L=70	△ * Q545	V4096000	TR	2SA1770 S,T(UC)
PN503	V3750200	PIN	L=70	△ Q545	VP872600	TR	2SA1708 ST(RATBGL)
PN504	V3750200	PIN	L=70	Q546	VP883100	TR	2SC1890A D,E
PN505	V3750200	PIN	L=70(RAT)	Q547	VP883100	TR	2SC1890A D,E
PN506	V3750200	PIN	L=70(RAT)	Q548	VP883100	TR	2SC1890A D,E
Q506	VP883100	TR	2SC1890A D,E	Q549	VP883100	TR	2SC1890A D,E
Q507	VP883100	TR	2SC1890A D,E	Q550	VP883100	TR	2SC1890A D,E
Q508	VP883100	TR	2SC1890A D,E	Q551	VP883000	TR	2SA893A D,E
Q509	VP883100	TR	2SC1890A D,E	△ Q552	iA1015I0	TR	2SA1015 Y
Q510	VP883100	TR	2SC1890A D,E	Q553	iC1815I0	TR	2SC1815 Y
Q511	VP883100	TR	2SC1890A D,E	Q554	VP883100	TR	2SC1890A D,E
* Q512	V3966800	TR	2SB949 O,Y	Q555	iC1815I0	TR	2SC1815 Y
Q513	VP883100	TR	2SC1890A D,E	△ Q557	VR510800	TR	2SD2396 J,K
* Q514	V3966800	TR	2SB949 O,Y	△ R516	HV754100	R.CAR.FP	10Ω 1/4W
Q515	VP883100	TR	2SC1890A D,E	R538	VP940400	R.MTL.OXD	100Ω 1W
* Q516	V3966800	TR	2SB949 O,Y	△ R543	HV756150	R.CAR.FP	1.5KΩ 1/4W
Q517	VP883100	TR	2SC1890A D,E	R545	VP940400	R.MTL.OXD	100Ω 1W
* Q518	V3966800	TR	2SB949 O,Y	R552	VP940400	R.MTL.OXD	100Ω 1W
Q519	VP883100	TR	2SC1890A D,E	R559	HV755100	R.CAR.FP	100Ω 1/4W
* Q520	V3966800	TR	2SB949 O,Y	R566	HV755100	R.CAR.FP	100Ω 1/4W
△ Q521	VK432900	TR	2SD1915F S,T	R567	VP941500	R.MTL.OXD	4.7KΩ 1W(RATBGL)
△ Q522	VK432900	TR	2SD1915F S,T	R567	VP941600	R.MTL.OXD	5.6KΩ 1W(UC)
△ Q523	VK432900	TR	2SD1915F S,T	* R569	V3946100	R.MTL.OXD	2.7KΩ 0.5W
△ Q524	VK432900	TR	2SD1915F S,T	* R570	V3945100	R.MTL.OXD	390Ω 0.5W
△ Q525	VK432900	TR	2SD1915F S,T	* R571	V3945600	R.MTL.OXD	1KΩ 0.5W
△ * Q526	V4096100	TR	2SC4614 S,T(UC)	* R572	V3945500	R.MTL.OXD	820Ω 0.5W
△ Q526	VP872700	TR	2SC4488 ST(RATBGL)	R573	VP941500	R.MTL.OXD	4.7KΩ 1W(RATBGL)
△ Q527	VR355900	TR.PAIR	2SA1695/C4468 OPY	R573	VP941600	R.MTL.OXD	5.6KΩ 1W(UC)
Q528	iC1815I0	TR	2SC1815 Y	* R575	V3946100	R.MTL.OXD	2.7KΩ 0.5W
△ * Q529	V4096000	TR	2SA1770 S,T(UC)	* R576	V3945100	R.MTL.OXD	390Ω 0.5W
△ Q529	VP872600	TR	2SA1708 ST(RATBGL)	* R577	V3945600	R.MTL.OXD	1KΩ 0.5W

\* New Parts

\* New Parts

## P. C. B. MAIN

Schm Ref	PART NO.	Description			Schm Ref	PART NO.	Description		
* R578	V3945500	R.MTL.OXD	820Ω	0.5W	△ R662	VP940800	R.MTL.OXD	470Ω	1W(RATBGL)
* R579	VP941500	R.MTL.OXD	4.7KΩ	1W(RATBGL)	△ R662	VP940900	R.MTL.OXD	560Ω	1W(UC)
R579	VP941600	R.MTL.OXD	5.6KΩ	1W(UC)	△ R663	HV755100	R.CAR.FP	100Ω	1/4W
R580	VP941500	R.MTL.OXD	4.7KΩ	1W(RATBGL)	△ R664	HV756100	R.CAR.FP	1KΩ	1/4W
R580	VP941600	R.MTL.OXD	5.6KΩ	1W(UC)	△ R665	VP940800	R.MTL.OXD	470Ω	1W(RATBGL)
* R581	V3946100	R.MTL.OXD	2.7KΩ	0.5W	△ R665	VP940900	R.MTL.OXD	560Ω	1W(UC)
* R582	V3945100	R.MTL.OXD	390Ω	0.5W	△ R666	VP940800	R.MTL.OXD	470Ω	1W(RATBGL)
* R583	V3945600	R.MTL.OXD	1KΩ	0.5W	△ R666	VP940900	R.MTL.OXD	560Ω	1W(UC)
* R584	V3945500	R.MTL.OXD	820Ω	0.5W	R672	HV755100	R.CAR.FP	100Ω	1/4W
R585	VP941500	R.MTL.OXD	4.7KΩ	1W(RATBGL)	R673	HV755100	R.CAR.FP	100Ω	1/4W
R585	VP941600	R.MTL.OXD	5.6KΩ	1W(UC)	△ R688	V3873200	R.WW	0.22Ω	3W
R586	VP941500	R.MTL.OXD	4.7KΩ	1W(RATBGL)	△ R690	V3873200	R.WW	0.22Ω	3W
R586	VP941600	R.MTL.OXD	5.6KΩ	1W(UC)	△ R691	VP939700	R.MTL.FLM	4.7Ω	1W
* R587	V3946100	R.MTL.OXD	2.7KΩ	0.5W	△ R692	V3873200	R.WW	0.22Ω	3W
* R588	V3945100	R.MTL.OXD	390Ω	0.5W	△ R693	VP939700	R.MTL.FLM	4.7Ω	1W
* R589	V3945600	R.MTL.OXD	1KΩ	0.5W	△ R694	VU981700	R.MTL.PLAT	0.22Ω+0.22Ω	3W
* R590	V3945500	R.MTL.OXD	820Ω	0.5W	△ R695	VP939700	R.MTL.FLM	4.7Ω	1W
R591	VP941500	R.MTL.OXD	4.7KΩ	1W(RATBGL)	△ R696	VU981700	R.MTL.PLAT	0.22Ω+0.22Ω	3W
R591	VP941600	R.MTL.OXD	5.6KΩ	1W(UC)	R697	HV753470	R.CAR.FP	4.7Ω	1/4W(RATBGL)
R592	VP941500	R.MTL.OXD	4.7KΩ	1W(RATBGL)	R698	HV753470	R.CAR.FP	4.7Ω	1/4W(RATBGL)
R592	VP941600	R.MTL.OXD	5.6KΩ	1W(UC)	R699	HV753470	R.CAR.FP	4.7Ω	1/4W(RATBGL)
* R593	V3946100	R.MTL.OXD	2.7KΩ	0.5W	R711	VP940900	R.MTL.OXD	560Ω	1W
* R594	V3945100	R.MTL.OXD	390Ω	0.5W	R712	VP940900	R.MTL.OXD	560Ω	1W
* R595	V3945600	R.MTL.OXD	1KΩ	0.5W	△ R763	HV753100	R.CAR.FP	1Ω	1/4W
* R596	V3945500	R.MTL.OXD	820Ω	0.5W	△ R764	HV753100	R.CAR.FP	1Ω	1/4W
R597	VP941500	R.MTL.OXD	4.7KΩ	1W(RATBGL)	△ R768	HV756470	R.CAR.FP	4.7KΩ	1/4W
R597	VP941600	R.MTL.OXD	5.6KΩ	1W(UC)	R769	VP939700	R.MTL.FLM	4.7Ω	1W(RATBGL)
△ R598	VP939700	R.MTL.FLM	4.7Ω	1W	R770	VP939700	R.MTL.FLM	4.7Ω	1W(RATBGL)
△* R599	V3944800	R.MTL.OXD	220Ω	0.5W	△ RY501	VK438300	RELAY	DH24D2-OT/M2	
R600	VP941500	R.MTL.OXD	4.7KΩ	1W(RATBGL)	△ RY502	VU566700	RELAY	DG24D2-OS/M	
R600	VP941600	R.MTL.OXD	5.6KΩ	1W(UC)	△ RY503	VK438300	RELAY	DH24D2-OT/M2	
△ R602	VP939700	R.MTL.FLM	4.7Ω	1W	ST501	BB071360	SCR.TERM	8.3x13	
△ R603	VP939700	R.MTL.FLM	4.7Ω	1W	ST502	BB071360	SCR.TERM	8.3x13	
△* R605	V3944800	R.MTL.OXD	220Ω	0.5W	ST503	BB071360	SCR.TERM	8.3x13	
△ R607	VP939700	R.MTL.FLM	4.7Ω	1W	ST504	BB071360	SCR.TERM	8.3x13	
△ R608	VP939800	R.MTL.OXD	10Ω	1W	ST505	BB071360	SCR.TERM	8.3x13	
△ R609	HV754100	R.CAR.FP	10Ω	1/4W	SW711	VV523900	SW.PUSH	PBS-YM-001	
△* R610	V3944800	R.MTL.OXD	220Ω	0.5W	△ SW761	V4104200	SW.SLIDE	SL13B-022-AMCS	
△ R611	VP939800	R.MTL.OXD	10Ω	1W	TE501	V4470700	TERM.SP	6P(UCRAT)	
△ R612	HV754100	R.CAR.FP	10Ω	1/4W	* TE501	V4470900	TERM.SP	6P(BGL)	
△* R614	V3944800	R.MTL.OXD	220Ω	0.5W	* TE701	V4811400	TERM.SP	8P(BGL)	
△ R615	HV754100	R.CAR.FP	10Ω	1/4W	TE701	VC313700	TERM.SP	8P(UCRAT)	
△ R616	HV754100	R.CAR.FP	10Ω	1/4W		BB070700	GND.MTL		
△* R617	V3944800	R.MTL.OXD	220Ω	0.5W					
△ R619	HV754100	R.CAR.FP	10Ω	1/4W					
△ R624	VP939800	R.MTL.OXD	10Ω	1W					
△ R629	VP939800	R.MTL.OXD	10Ω	1W					
△ R634	VP939800	R.MTL.OXD	10Ω	1W					
△ R639	VP939800	R.MTL.OXD	10Ω	1W					
△ R644	VP939800	R.MTL.OXD	10Ω	1W					
R653	HV755100	R.CAR.FP	100Ω	1/4W					
R660	HV755100	R.CAR.FP	100Ω	1/4W					
R661	HV755100	R.CAR.FP	100Ω	1/4W					

\* New Parts

\* New Parts

<b>P. C. B. TUNER</b>
-----------------------

## • Lead Type

Schm Ref	PART NO.	Description	
	V2518600	P.C.B.	TUNER/TU-01NC(UC)
	V2518700	P.C.B.	TUNER/TU-01NC(RT)
	V2518800	P.C.B.	TUNERTU-01NC(ABGL)
	V2518900	P.C.B.	TUNERTU01RDSNC(BG)
CB4	VQ961900	CN	16P
C1	VG287600	C.EL	100uF 25V
C3	VG275800	C.CE.TUBLR	8.2pF 50V
C4	UR837470	C.EL	47uF 16V
C5	VF467300	C.CE.TUBLR	0.01uF 16V
C6	UR837470	C.EL	47uF 16V
C7	UM416100	C.EL	1uF 50V
C8	VF467300	C.CE.TUBLR	0.01uF 16V
C9	VF467300	C.CE.TUBLR	0.01uF 16V
C10	VF467300	C.CE.TUBLR	0.01uF 16V
C11	VF467000	C.CE.TUBLR	1000pF 50V
C12	UM397100	C.EL	10uF 16V
C13	UM397100	C.EL	10uF 16V
C14	FG652100	C.CE	100pF 50V
C15	VF467000	C.CE.TUBLR	1000pF 50V
C16	VF466700	C.CE.TUBLR	47pF 50V
C17	UR837470	C.EL	47uF 16V
C19	VA760600	C.CE	10pF 50V
C20	VG287600	C.EL	100uF 25V
C21	VJ599000	C.CE.TUBLR	0.047uF 16V
C22	VG290700	C.EL	3.3uF 50V
C23	VF467300	C.CE.TUBLR	0.01uF 16V
C24	UM406470	C.EL	4.7uF 50V
C25	UM416330	C.EL	3.3uF 50V
C26	UM397100	C.EL	10uF 16V
C27	VF467300	C.CE.TUBLR	0.01uF 16V
C28	VA760600	C.CE	10pF 50V
C29	UM416100	C.EL	1uF 50V
C30	UM416100	C.EL	1uF 50V
C31	VG287600	C.EL	100uF 25V
C32	UM415470	C.EL	0.47uF 50V
C33	UM416100	C.EL	1uF 50V
C34	UA954470	C.MYLAR	0.047uF 50V
C35	VG290700	C.EL	3.3uF 50V
C36	UA952270	C.MYLAR	270pF 50V(ABGL)
C36	UA953100	C.MYLAR	1000pF 50V(UCRT)
C36	V3451700	C.PP	270pF 100V(RDS BG)
C37	UA952270	C.MYLAR	270pF 50V(ABGL)
C37	UA953100	C.MYLAR	1000pF 50V(UCRT)
C37	V3451700	C.PP	270pF 100V(RDS BG)
C38	VF466900	C.CE.TUBLR	470pF 50V
C39	VG287200	C.EL	10uF 50V
C39	VQ082700	C.EL	10uF 16V(RDS BG)
C40	VE020000	C.EL	3.3uF 50V(RDS BG)
C40	VG290700	C.EL	3.3uF 50V
C41	UA953390	C.MYLAR	3900pF 50V
C41	VL884100	C.PP	3900pF 100V(RDS BG)
C42	UM397220	C.EL	22uF 25V
C43	UA953390	C.MYLAR	3900pF 50V

\* New Parts

Schm Ref	PART NO.	Description	
C43	VL884100	C.PP	3900pF 100V(RDS BG)
C44	VE020000	C.EL	3.3uF 50V(RDS BG)
C44	VG290700	C.EL	3.3uF 50V
C45	UR837470	C.EL	47uF 16V
C46	UR837470	C.EL	47uF 16V
C47	VG278600	C.CE.TUBLR	330pF 50V
C48	VG278800	C.CE.TUBLR	560pF 50V
C49	UA952120	C.MYLAR	120pF 50V(ABGL)
C49	UA953220	C.MYLAR	2200pF 50V(UCRT)
C49	V3451600	C.PP	120pF 100V(RDS BG)
C50	VJ599000	C.CE.TUBLR	0.047uF 16V
C51	UR837470	C.EL	47uF 16V
C52	UR837470	C.EL	47uF 16V
C53	UR837470	C.EL	47uF 16V
C54	VA761100	C.CE	27pF 50V
C55	VA761100	C.CE	27pF 50V
C56	VJ599000	C.CE.TUBLR	0.047uF 16V
C57	VG278600	C.CE.TUBLR	330pF 50V
C59	VF467300	C.CE.TUBLR	0.01uF 16V(UC)
D1	VD631600	DIODE	1SS133,176,HSS104
D2	VD631600	DIODE	1SS133,176,HSS104
D3	VG437700	DIODE.ZENR	MTZJ5.6B 5.6V
Fi1	GG000560	FLTR.CE	SFE10.7MS3GHY-A
Fi2	GG000560	FLTR.CE	SFE10.7MS3GHY(UCRT)
Fi2	V4545200	FLTR.CE	SFE10.7MJA1(ABGL)
Fi3	VC219000	FLTR.CE	SFZ450JL3
IC1	XB760A00	IC	LA1266
IC2	XQ944A00	IC	LC72131
IC3	iG158100	IC	LA3401
IC4	XY534A00	IC	LC72722(RDS BG)
L1	Vi546100	COIL	220uH
L2	Vi546100	COIL	220uH
L3	Vi546100	COIL	220uH
L4	Vi546100	COIL	220uH
L5	Vi546100	COIL	220uH
PK1	V2716700	TUNER.PK	ENV172A4G1(ABGL)
PK1	V2909100	TUNER.PK	ENV-172C8G1R(UCRT)
PK2	VU333700	COIL.RF.AM	940536051A
Q1	iC053540	TR	2SC535 A,B,C
Q2	iC053540	TR	2SC535 A,B,C
Q3	VD678500	TR.DGT	DTA114ES
Q4	iC174020	TR	2SC1740S R,S
Q5	VG722000	TR.DGT	DTC144ES
Q6	iC1815I0	TR	2SC1815 Y
Q7	VD678500	TR.DGT	DTA114ES
R56	HV754470	R.CAR.FP	47Ω 1/4W(ABGL)
R56	HV755100	R.CAR.FP	100Ω 1/4W(UCRT)
SW1	VS602600	SW.SLIDE	SS070-P022 A(RT)
T1	V3725400	COIL.DT	10.7MHZ 104A
T2	VR895700	COIL.IF	450KHz
T3	VT486800	COIL	XYA2(ABGL)
T4	VQ138200	FLTR.LC	19KHz
T5	VQ138200	FLTR.LC	19KHz

\* New Parts

**P. C. B. TUNER**

**P. C. B. TUNER**

**Chip Resistors**

Schm Ref	PART NO.	Description	
TE1	VU477800	TERM.ANT	AJ-2038-040
TP1	VT969000	PIN.TEST	IRS-2049
TP2	VT969000	PIN.TEST	IRS-2049
VR1	VJ694000	VR.TRIM	B47KΩ
VR2	VJ694000	VR.TRIM	B47KΩ
XL1	VY734600	RSNR.CRYS	7.2MHz
XL2	GG000750	RSNR.CE	456KHz
XL3	V3930900	RSNR.CRYS	4.332MHz
	BB071360	SCR.TERM	8.3x13
	VR282500	PLATE	ANT.

Schm Ref	PART NO.	Description		
C32	UM415470	C.EL	0.47uF	50V
C33	UM416100	C.EL	1uF	50V
C34	UA954470	C.MYLAR	0.047uF	50V
C35	VG290700	C.EL	3.3uF	50V
C36	UA952270	C.MYLAR	270pF	50V(ABGL)
C36	UA953100	C.MYLAR	1000pF	50V(UCRT)
C36	V3451700	C.PP	270pF	100V(RDS BG)
C37	UA952270	C.MYLAR	270pF	50V(ABGL)
C37	UA953100	C.MYLAR	1000pF	50V(UCRT)
C37	V3451700	C.PP	270pF	100V(RDS BG)
C38	UB012470	C.CE.M.CHP	470pF	50V
C39	VG287200	C.EL	10uF	50V
C39	VQ082700	C.EL	10uF	16V(RDS BG)
C40	VE020000	C.EL	3.3uF	50V(RDS BG)
C40	VG290700	C.EL	3.3uF	50V
C41	UA953390	C.MYLAR	3900pF	50V
C41	VL884100	C.PP	3900pF	100V(RDS BG)
C42	UM397220	C.EL	22uF	25V
C43	UA953390	C.MYLAR	3900pF	50V
C43	VL884100	C.PP	3900pF	100V(RDS BG)
C44	VE020000	C.EL	3.3uF	50V(RDS BG)
C44	VG290700	C.EL	3.3uF	50V
C45	UR837470	C.EL	47uF	16V
C46	UR837470	C.EL	47uF	16V
C47	UB012330	C.CE.M.CHP	330pF	50V
C48	UB012560	C.CE.M.CHP	560pF	50V
C49	UA952120	C.MYLAR	120pF	50V(ABGL)
C49	UA953220	C.MYLAR	2200pF	50V(UCRT)
C49	V3451600	C.PP	120pF	100V(RDS BG)
C50	UB044470	C.CE.M.CHP	0.047uF	50V
C51	UR837470	C.EL	47uF	16V
C52	UR837470	C.EL	47uF	16V
C53	UR837470	C.EL	47uF	16V
C54	VA761100	C.CE	27pF	50V
C55	VA761100	C.CE	27pF	50V
C56	UB044470	C.CE.M.CHP	0.047uF	50V
C57	UB012330	C.CE.M.CHP	330pF	50V
C59	VF467300	C.CE.TUBLR	0.01uF	16V(UC)
D1	VT332900	DIODE	1SS355	
D2	VT332900	DIODE	1SS355	
D3	VU172000	DIODE.ZENR	UDZS5.6BTE-17 5.6V	
Fi1	GG000560	FLTR.CE	SFE10.7MS3GHY-A	
Fi2	GG000560	FLTR.CE	SFE10.7MS3GHY(UCRT)	
Fi2	V4545200	FLTR.CE	SFE10.7MJA1(ABGL)	
Fi3	VC219000	FLTR.CE	SFZ450JL3	
IC1	XB760A00	IC	LA1266	
IC2	XQ944A00	IC	LC72131	
IC3	iG158100	IC	LA3401	
IC4	XY534A00	IC	LC72722(RDS BG)	
L1	VU889500	COIL	220uH	
L2	VU889500	COIL	220uH	
L3	VU889500	COIL	220uH	
L4	VU889500	COIL	220uH	
L5	VU889500	COIL	220uH	

Schm Ref	PART NO.	Description	
PK1	V2716700	TUNER.PK	ENV-172A4G1(ABGL)
PK1	V2909100	TUNER.PK	ENV-172C8G1R(UCRT)
PK2	VU333700	COIL.RF.AM	940536051A
Q1	iC053540	TR	2SC535 A,B,C
Q2	iC053540	TR	2SC535 A,B,C
Q3	VD678500	TR.DGT	DTA114ES
Q4	iC174020	TR	2SC1740S R,S
Q5	VG722000	TR.DGT	DTC144ES
Q6	iC181510	TR	2SC1815 Y
Q7	VD678500	TR.DGT	DTA114ES
R56	HV754470	R.CAR.FP	47Ω 1/4W(ABGL)
R56	HV755100	R.CAR.FP	100Ω 1/4W(UCRT)
SW1	VS602600	SW.SLIDE	SS070-P022 A(RT)
T1	V3725400	COIL.DT	10.7MHZ 104A
T2	VR895700	COIL.IF	450KHz
T3	VT486800	COIL	XYA2(ABGL)
T4	VQ138200	FLTR.LC	19KHz
T5	VQ138200	FLTR.LC	19KHz
TE1	VU477800	TERM.ANT	AJ-2038-040
TP1	VT969000	PIN.TEST	IRS-2049
TP2	VT969000	PIN.TEST	IRS-2049
VR1	VJ694000	VR.TRIM	B47KΩ
VR2	VJ694000	VR.TRIM	B47KΩ
XL1	VY734600	RSNR.CRYS	7.2MHz
XL2	GG000750	RSNR.CE	456KHz
XL3	V3930900	RSNR.CRYS	4.332MHz
	BB071360	SCR.TERM	8.3x13
	VR282500	PLATE	ANT.

Schm Ref	PART NO.	Description		
	RD254470	R.CAR.CHP	47Ω	1/10W
	RD255100	R.CAR.CHP	100Ω	1/10W
	RD255330	R.CAR.CHP	330Ω	1/10W
	RD256100	R.CAR.CHP	1KΩ	1/10W
	RD256120	R.CAR.CHP	1.2KΩ	1/10W
	RD256150	R.CAR.CHP	1.5KΩ	1/10W
	RD256220	R.CAR.CHP	2.2KΩ	1/10W
	RD256330	R.CAR.CHP	3.3KΩ	1/10W
	RD256360	R.CAR.CHP	3.6KΩ	1/10W
	RD256390	R.CAR.CHP	3.9KΩ	1/10W
	RD256470	R.CAR.CHP	4.7KΩ	1/10W
	RD256680	R.CAR.CHP	6.8KΩ	1/10W
	RD256820	R.CAR.CHP	8.2KΩ	1/10W
	RD256910	R.CAR.CHP	9.1KΩ	1/10W
	RD257100	R.CAR.CHP	10KΩ	1/10W
	RD257160	R.CAR.CHP	16KΩ	1/10W
	RD257470	R.CAR.CHP	47KΩ	1/10W
	RD258100	R.CAR.CHP	100KΩ	1/10W
	RD258470	R.CAR.CHP	470KΩ	1/10W
	RD259100	R.CAR.CHP	1MΩ	1/10W

\* New Parts

**• Lead Type & SMD**

Schm Ref	PART NO.	Description	
	V2519300	P.C.B.	TUNER/TU-01CP(UC)
	V2519400	P.C.B.	TUNER/TU-01CP(RT)
	V2519500	P.C.B.	TUNER/TU-01CP(ABGL)
	V2519600	P.C.B.	TUNERTU01RDSCP(BG)
CB4	VQ961900	CN	16P
C1	VG287600	C.EL	100uF 25V
C3	UB050800	C.CE.M.CHP	8pF 50V
C4	UR837470	C.EL	47uF 16V
C5	UB044100	C.CE.M.CHP	0.01uF 50V
C6	UR837470	C.EL	47uF 16V
C7	UM416100	C.EL	1uF 50V
C8	UB044100	C.CE.M.CHP	0.01uF 50V
C9	UB044100	C.CE.M.CHP	0.01uF 50V
C10	UB044100	C.CE.M.CHP	0.01uF 50V
C11	UB013100	C.CE.M.CHP	1000pF 50V
C12	UM397100	C.EL	10uF 16V
C13	UM397100	C.EL	10uF 16V
C14	FG652100	C.CE	100pF 50V
C15	UB013100	C.CE.M.CHP	1000pF 50V
C16	UB051470	C.CE.M.CHP	47pF 50V
C17	UR837470	C.EL	47uF 16V
C19	VA760600	C.CE	10pF 50V
C20	VG287600	C.EL	100uF 25V
C21	UB044470	C.CE.M.CHP	0.047uF 50V
C22	VG290700	C.EL	3.3uF 50V
C23	UB044100	C.CE.M.CHP	0.01uF 50V
C24	UM406470	C.EL	4.7uF 50V
C25	UM416330	C.EL	3.3uF 50V
C26	UM397100	C.EL	10uF 16V
C27	UB044100	C.CE.M.CHP	0.01uF 50V
C28	VA760600	C.CE	10pF 50V
C29	UM416100	C.EL	1uF 50V
C30	UM416100	C.EL	1uF 50V
C31	VG287600	C.EL	100uF 25V

\* New Parts

\* New Parts

\* New Parts

\* New Parts



Ref. No.	PART NO.	Description	Remarks	Markets
7	V2518700	P.C.B. ASS'Y	TUNER/TU-01 NC	(RT)
7	V2518800	P.C.B. ASS'Y	TUNER/TU-01 NC	(AL)
7	V2518900	P.C.B. ASS'Y	TUNER/TU-01RDS NC	(BG)
* 8	V4800300	P.C.B. ASS'Y	INPUT	(UCRT)
* 8	V4800400	P.C.B. ASS'Y	INPUT	(ABGL)
* 10	V4801600	P.C.B. ASS'Y	POWER	(UC)
* 10	V4801700	P.C.B. ASS'Y	POWER	(RT)
* 10	V4801800	P.C.B. ASS'Y	POWER	(A)
* 10	V4801900	P.C.B. ASS'Y	POWER	(B)
* 10	V4802000	P.C.B. ASS'Y	POWER	(GL)
△* 15	XW611A00	POWER TRANSFORMER		(C)
△* 15	XW612A00	POWER TRANSFORMER		(RT)
△* 15	XW613A00	POWER TRANSFORMER		(A)
△* 15	XW614A00	POWER TRANSFORMER		(BGL)
△* 15	XY191A00	POWER TRANSFORMER		(U)
△ 16	V2296800	POWER CORD ASS'Y		(A)
△* 16	V2363800	POWER CORD ASS'Y		(UC)
△ 16	VN363700	POWER CORD ASS'Y		(GL)
△ 16	VV437300	POWER CORD ASS'Y		(B)
△ 16	VZ542500	POWER CORD ASS'Y		(RT)
17	V2438700	CORD STOPPER	10P1	
23	MF219140	S FLEXIBLE FLAT CABLE	19P 140mm	
24	MF120200	FLEXIBLE FLAT CABLE	20P 200mm	
25	MF123140	FLEXIBLE FLAT CABLE	23P 140mm	
26	MF113140	FLEXIBLE FLAT CABLE	13P 140mm	
27	MF207200	S FLEXIBLE FLAT CABLE	7P 200mm	
* 28	MF207350	S FLEXIBLE FLAT CABLE	7P 350mm	
101	VV121300	TOP COVER		BL
101	VV121500	TOP COVER		TI
101	VZ884500	TOP COVER		GD
102	V2460600	CHASSIS		
* 103	V4167100	REAR PANEL		RX-V596 (U)
* 103	V4167200	REAR PANEL		RX-V596 (C)
* 103	V4167300	REAR PANEL		RX-V596 (RT)
* 103	V4167400	REAR PANEL		RX-V596 (A)
* 103	V4167500	REAR PANEL		RX-V596 (L)
* 103	V4167600	REAR PANEL		RX-V596RDS (B)
* 103	V4167700	REAR PANEL		RX-V596RDS (G)
* 103	V4168000	REAR PANEL		HTR-5250 (U)
* 103	V4168100	REAR PANEL		HTR-5250 (C)
* 103	V4168200	REAR PANEL		HTR-5250 (T)
* 103	V4168300	REAR PANEL		HTR-5250 (A)
109	V2461100	SHIELD CASE		
110	VZ332800	SHIELD CASE COVER		(UC)
112	V4168900	FRAME, PCB		
120	V0042500	LEG	D60xH21	GD,5250BL(T)
120	VS025000	LEG	D60xH21	BL, TI
120	VV544300	LEG	D60xH21	5250BL(UCA) (UCA)
* 121	V4172900	KNOB D40		BL
* 121	V4173000	KNOB D40		TI
121	V4173100	KNOB D40		GD
* 122	V4172600	KNOB D30 ENC		BL
122	V4172700	KNOB D30 ENC		TI

\* New Parts

Ref. No.	PART NO.	Description	Remarks	Markets
122	V4172800	KNOB D30 ENC	GD	
* 123	V4172000	KNOB	BL	
* 123	V4172100	KNOB	TI	
123	V4172200	KNOB	GD	
124	V2918800	BUTTON	3x8	BL
124	V2918900	BUTTON	3x8	TI
124	V4562700	BUTTON	3x8	GD
128	V2469400	SHEET, WINDOW		
* 131	V4170300	PLATE SIDE L	BL	
* 131	V4170400	PLATE SIDE L	TI	
131	V4170500	PLATE SIDE L	GD	
* 132	V4170600	PLATE SIDE R	BL	
* 132	V4170700	PLATE SIDE R	TI	
132	V4170800	PLATE SIDE R	GD	
135	VR264400	SPACER	H8	
137	V5901100	DAMPER	10x50xT7	(UC)
138	V2879500	SPACER PCB-M		
155	VQ368600	PUSH RIVET	P3555-B	
160	VN413300	BIND HEAD BONDING B-T. SCREW	3x8 MFZN2-BL	
161	VY731200	BONDING HEAD TAPPING SCREW	3x10 MFNI33	
162	EP600830	BIND HEAD B-TITE SCREW	3x8 FCRM3-BL	
163	EP600250	BIND HEAD B-TITE SCREW	3x8 ZMC2-Y	
166	EG330030	BIND HEAD SCREW	3x6 FCRM3-BL	
167	VT669300	PW HEAD B-TITE SCREW	3x8-8 MFC2	
168	VT669400	PW HEAD B-TITE SCREW	3x15-8 MFC2	
170	21991500	PW HEAD S-TITE SCREW	4x8-10 FCRM3-BL	BL
171	21991500	PW HEAD S-TITE SCREW	4x8-10 FCRM3-BL	BL
171	VD069600	PW HEAD S-TITE SCREW	4x8-10 MFNI-33	GD
171	VH313200	BW HEAD S-TITE SCREW	4x8-10 FNM3-BL	TI
176	AA627310	GROUND TERMINAL		
178	03700480	HEXAGONAL CAP NUT	4.0 MFNI33	
		ACCESSORIES		
* 200	V4297600	REMOTE CONTROL TRANSMITTER	SBGH20018A RAV210	(UCRALT)
* 200	V4297700	REMOTE CONTROL TRANSMITTER	SBGH20018A RAV211	(BG)
200-1	AAX14030	LID	BW0780/1	71078002000
201	VQ147100	ANTENNA, FM	1.4m	
202	VR248500	ANTENNA, AM LOOP	1.0m	
203	VT948000	ANTENNA ADAPTER		(UC)
204	VE364900	ANTENNA ADAPTER	PAL 75-300Ω	(B)
		BATTERY, MANGANESE	SUM-4,AAA,R03	

\* New Parts

# Parts List for Carbon Resistors

Value	1/4W Type Part No.	1/6W Type Part No.	Value	1/4W Type Part No.	1/6W Type Part No.
1.0 Ω	HJ35 3100	HF85 3100	10 kΩ	HF45 7100	HF45 7100
1.8 Ω	HJ35 3180	*	11 kΩ	HF45 7110	HF45 7110
2.2 Ω	HJ35 3220	HF85 3220	12 kΩ	HJ35 7120	HF85 7120
3.3 Ω	HJ35 3330	HF85 3330	13 kΩ	HF45 7130	HF45 7130
4.7 Ω	HJ35 3470	HF85 3470	15 kΩ	HF45 7150	HF45 7150
5.6 Ω	HJ35 3560	HF85 3560	18 kΩ	HF45 7180	HF45 7180
10 Ω	HF45 4100	HF45 4100	22 kΩ	HF45 7220	HF45 7220
15 Ω	HJ35 4150	HF85 4150	24 kΩ	HF45 7240	HF45 7240
22 Ω	HF45 4220	HF45 4220	27 kΩ	HJ35 7270	HF85 7270
27 Ω	HJ35 4270	HF85 4270	30 kΩ	HF45 7300	HF45 7300
33 Ω	HF45 4330	HF45 4330	33 kΩ	HF45 7330	HF45 7330
39 Ω	HJ35 4390	HF85 4390	36 kΩ	HF45 7360	HF45 7360
47 Ω	HF45 4470	HF45 4470	39 kΩ	HF45 7390	HF45 7390
56 Ω	HF45 4560	HF45 4560	47 kΩ	HF45 7470	HF45 7470
68 Ω	HF45 4680	HF45 4680	51 kΩ	HF45 7510	HF45 7510
75 Ω	HF45 4750	HF45 4750	56 kΩ	HF45 7560	HF45 7560
82 Ω	HF45 4820	HF45 4820	62 kΩ	HF45 7620	HF45 7620
91 Ω	HF45 4910	HF45 4910	68 kΩ	HF45 7680	HF45 7680
100 Ω	HF45 5100	HF45 5100	82 kΩ	HF45 7820	HF45 7820
110 Ω	HJ35 5110	HF85 5110	91 kΩ	HF45 7910	HF45 7910
120 Ω	HF45 5120	HF45 5120	100 kΩ	HF45 8100	HF45 8100
150 Ω	HF45 5150	HF45 5150	110 kΩ	HF45 8110	HF45 8110
160 Ω	HJ35 5160	*	120 kΩ	HF45 8120	HF45 8120
180 Ω	HF45 5180	HF45 5180	150 kΩ	HF45 8150	HF45 8150
200 Ω	HF45 5200	HF45 5200	180 kΩ	HF45 8180	HF45 8180
220 Ω	HF45 5220	HF45 5220	220 kΩ	HJ35 8220	HF85 8220
270 Ω	HF45 5270	HF45 5270	270 kΩ	HF45 8270	HF45 8270
330 Ω	HF45 5330	HF45 5330	300 kΩ	HF45 8300	HF45 8300
390 Ω	HF45 5390	HF45 5390	330 kΩ	HF45 8330	HF45 8330
430 Ω	HF45 5430	HF45 5430	390 kΩ	HJ35 8390	HF85 8390
470 Ω	HF45 5470	HF45 5470	470 kΩ	HF45 8470	HF45 8470
510 Ω	HF45 5510	HF45 5510	560 kΩ	HJ35 8560	HF85 8560
560 Ω	HF45 5560	HF45 5560	680 kΩ	HJ35 8680	HF85 8680
680 Ω	HF45 5680	HF45 5680	820 kΩ	HJ35 8820	HF85 8820
820 Ω	HF45 5820	HF45 5820	1.0 MΩ	HF45 9100	HF45 9100
910 Ω	HF45 5910	HF45 5910	1.2 MΩ	HJ35 9120	*
1.0 kΩ	HF45 6100	HF45 6100	1.5 MΩ	HJ35 9150	HF85 9150
1.2 kΩ	HF45 6120	HF45 6120	1.8 MΩ	HJ35 9180	HF85 9180
1.5 kΩ	HF45 6150	HF45 6150	2.2 MΩ	HJ35 9220	HF85 9220
1.8 kΩ	HF45 6180	HF45 6180	3.3 MΩ	HJ35 9330	HF85 9330
2.0 kΩ	HJ35 6200	HF85 6200	3.9 MΩ	HJ35 9390	*
2.2 kΩ	HF45 6220	HF45 6220	4.7 MΩ	HJ35 9470	HF85 9470
2.4 kΩ	HJ35 6240	HF85 6240			
2.7 kΩ	HF45 6270	HF45 6270			
3.0 kΩ	HF45 6300	HF45 6300			
3.3 kΩ	HF45 6330	HF45 6330			
3.6 kΩ	HJ35 6360	HF85 6360			
3.9 kΩ	HF45 6390	HF45 6390			
4.7 kΩ	HF45 6470	HF45 6470			
5.1 kΩ	HF45 6510	HF45 6510			
5.6 kΩ	HF45 6560	HF45 6560			
6.8 kΩ	HF45 6680	HF45 6680			
8.2 kΩ	HF45 6820	HF45 6820			
9.1 kΩ	HF45 6910	HF45 6910			

**1/4W Type**  
HJ35 ○○○○

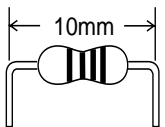

10mm

**1/4W Type**  
HF45 ○○○○

**1/6W Type**  
HF85 ○○○○

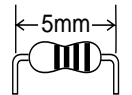

5mm

\*: Not available

# REMOTE CONTROL TRANSMITTER

(RAV210 or RAV211)  
 • U,C,R,T,A and L models → RAV210  
 • B and G models → RAV211

## SCHEMATIC DIAGRAM

## Key Arrangement

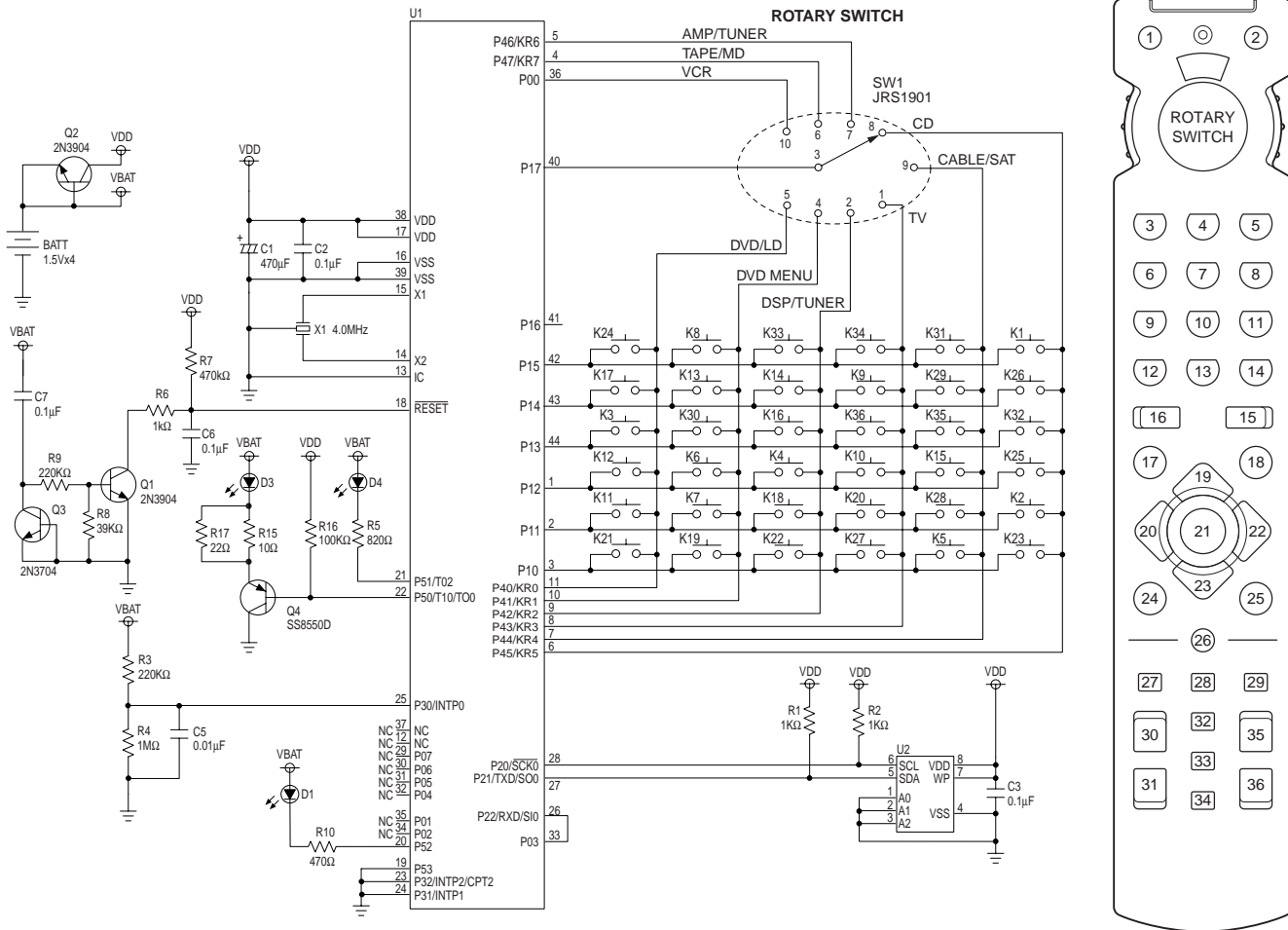

## List of the Functional key

Key No.	Key Name	TV	VCR	CABLE/SAT	CD	AMP/TUNER	TAPE/MD	DVD/MENU	DVD/LD	DSP/TUNER
1	DSP									
2	INPUT									0023
3	1	CH1	CH1	CH1	1	CD	1	1	1	DD/dts/SUR P1
4	2	CH2	CH2	CH2	2	TUNER	2	2	2	MOVIE THTR1 P2
5	3	CH3	CH3	CH3	3	TAPE/MD	3	3	3	MOVIE THTR2 P3
6	4	CH4	CH4	CH4	4	DVD/LD	4	4	4	MPNO MOVIE P4
7	5	CH5	CH5	CH5	5	D-TV	5	5	5	TV SPORTS P5
8	6	CH6	CH6	CH6	6	VCR(VCR1)	6	6	6	DISCO P6
9	7	CH7	CH7	CH7	7	PHONO	7	7	7	ROCK P7
10	8	CH8	CH8	CH8	8	CBL/SAT	8	8	8	JAZZ CLUB P8
11	9	CH9	CH9	CH9	9	V-AUX	9	9	9	CHURCH -
12	0	CH0	CH0	CH0	0	EXT DEC	0	0	0	HALL -
13	ENTER	CH Enter/Recall	CH Enter/Recall	CH Enter	INDEX	A/B/C/D/E	-	INDEX	INDEX	A/B/C/D/E <-
14	>10				+10	(VCR2)	+10	+10	+10	EFFECT -
15	CH+	TV CH+	VCR CH+	CBL/SAT CH+	DISC +	PRESET+	-	DISC +		PRESET+ <-
16	CH-	TV CH-	VCR CH-	CBL/SAT CH-	DISC -	PRESET-	-	DISC -		PRESET- <-
17	REC		VCR REC	-	-	TEST	REC/PAUSE	RETURN	-	TEST <-
18	DISPLAY	DISPLAY	DISPLAY	DISPLAY/GUIDE	DISPLAY	ON SCREEN	DISPLAY/A-B	DISPLAY	DISPLAY	ON SCREEN <-
19	PAUSE		VCR PAUSE	Up	PAUSE	Up	PAUSE	Up	PAUSE	Up <-
20	SKIP-	-	-	Left	SKIP-	Left	SKIP-/DIR A	Left	SKIP/CHAP-	Left <-
21	PLAY		VCR PLAY	Menu Select	PLAY	-	PLAY	Select	PLAY	- <-
22	SKIP+	-	-	Right	SKIP+	Right	SKIP+/DIR B	Right	SKIP/CHAP+	Right <-
23	STOP		VCR STOP	Down	STOP	Down	STOP	Down	STOP	Down <-
24	REW		VCR REW	RECALL	REW	TIME/LEVEL	REW	TITLE	REW	TIME/LEVEL <-
25	FF		VCR FF	MENU	FF	SET MENU	FF	MENU	FF	SET MENU <-
26	AV POWER		VCR POWER	CBL/SAT POWER	CD POWER	-	TAPE/MD POWER		DVD/LD POWER	- <-
27	TV POWER					TV POWER				
28	STANDBY					STANDBY (OFF)				
29	POWER					AMP POWER				
30	TV VOL+					TV VOL+				
31	TV VOL-					TV VOL-				
32	TV INPUT					TV INPUT				
33	SLEEP	TV SLEEP				SLEEP				
34	MUTE	TV MUTE				MUTE				
35	VOL+					VOL+				
36	VOL-					VOL-				
	Library	TV	VCR	CABLE SAT/SAT	CD	TUNER 0023	TAPE MD	(DVD)	DVD LD	TUNER 0023
	Change Device	x	x	AUX	x	x	x	AUX	x	x
	Default	0101	0002	0006	0005(Yamaha)	0003(AMP)	0004(Yamaha)	0008(Yamaha)		0013(DSP)

## List of the Yamaha Code (NEC Format)

Key No.	Key Name	DVD		DVD MENU		LD		CD		
			Yamaha 0008		Yamaha 0008		Yamaha 0007		Yamaha 0005	Yamaha 0015
3	1	1	7C-94	1	7C-94	1	7C-17	1	79-11	79-11
4	2	2	7C-95	2	7C-95	2	7C-18	2	79-12	79-12
5	3	3	7C-96	3	7C-96	3	7C-19	3	79-13	79-13
6	4	4	7C-97	4	7C-97	4	7C-1A	4	79-14	79-14
7	5	5	7C-98	5	7C-98	5	7C-1B	5	79-15	79-15
8	6	6	7C-99	6	7C-99	6	7C-1C	6	79-16	79-16
9	7	7	7C-9A	7	7C-9A	7	7C-1D	7	79-17	79-17
10	8	8	7C-9B	8	7C-9B	8	7C-1E	8	79-18	79-18
11	9	9	7C-9C	9	7C-9C	9	7C-1F	9	79-19	79-19
12	0	0	7C-93	0	7C-93	0	7C-16	0	79-10	79-10
13	ENTER	INDEX	7C-9E	INDEX	7C-9E	CHP/TIME	7C-15	INDEX	79-0B	79-0B
14	>10	+10	7C-9D	+10	7C-9D	+10	7C-5D	+10	79-1A	79-1A
15	CH+	DISC+	7C-8B	DISC+	7C-8B	DISC+	-	DISC+	7A-4F	79-4F
16	CH-	DISC-	7C-8A	DISC-	7C-8A	DISC-	-	DISC-	7A-50	79-50
17	REC	REC	-	RETURN	7C-B7	REC	-	REC	-	-
18	DISPLAY	DISPLAY	7C-A6	DISPLAY	7C-A6	DISPLAY	7C-13	DISPLAY	79-0A	79-0A
19	PAUSE	PAUSE	7C-B3	Up	7C-B4	PAUSE	7C-5A	PAUSE	7A-09	79-55
20	SKIP-	SKIP/CHAP-	7C-B9	Left	7C-B5	SKIP/CHAP-	7C-02	SKIP-	7A-0B	79-04
21	PLAY	PLAY	7C-B2	Select	7C-B8	PLAY	7C-05	PLAY	7A-08	79-02
22	SKIP+	SKIP/CHAP+	7C-BA	Right	7C-B6	SKIP/CHAP+	7C-03	SKIP+	7A-0A	79-07
23	STOP	STOP	7C-B5	Down	7C-B3	STOP	7C-5B	STOP	7A-06	79-56
24	REW	REW	7C-B6	TITLE	7C-B1	REW	7C-06	REW	7A-0D	79-05
25	FF	FF	7C-B7	MENU	7C-B2	FF	7C-07	FF	7A-0C	79-06
26	AV POWER	DVD POWER	7C-B0	DVD POWER	7C-B0	LD POWER	-	CD POWER	-	-
27	TV POWER		Punch Through		Punch Through		Punch Through		Punch Through	
28	STANDBY		Punch Through		Punch Through		Punch Through		Punch Through	
29	POWER		Punch Through		Punch Through		Punch Through		Punch Through	
30	TV VOL+		Punch Through		Punch Through		Punch Through		Punch Through	
31	TV VOL-		Punch Through		Punch Through		Punch Through		Punch Through	
32	TV INPUT		Punch Through		Punch Through		Punch Through		Punch Through	
33	SLEEP		Punch Through		Punch Through		Punch Through		Punch Through	
34	MUTE		Punch Through		Punch Through		Punch Through		Punch Through	
35	VOL+		Punch Through		Punch Through		Punch Through		Punch Through	
36	VOL-		Punch Through		Punch Through		Punch Through		Punch Through	

- : No Code

Key No.	Key Name	TAPE		MD		AMP/TUNER			
		Yamaha 0004	Yamaha 0014	Yamaha 0024		AMP 0003	DSP 0013	TUNER 0023	
3	1	1	-	-	79-85	CD	7A-15	7A-88	7A-E5
4	2	2	-	-	79-85	TUNER	7A-16	7A-89	7A-E6
5	3	3	-	-	79-87	TAPE/MD	7A-18	7A-8A	7A-E7
6	4	4	-	-	79-88	DVD/LD	7A-17	7A-8B	7A-E8
7	5	5	-	-	79-89	D-TV	7A-54	7A-8C	7A-E9
8	6	6	-	-	79-8A	VCR	7A-0F	7A-8D	7A-EA
9	7	7	-	-	79-8B	PHONO	7A-14	7A-8E	7A-EB
10	8	8	-	-	79-8C	CBL/SAT	7A-C0	7A-8F	7A-EC
11	9	9	-	-	79-8D	V-AUX	7A-55	7A-90	-
12	0	0	-	-	79-8E	EXT.DEC.	7A-87	7A-91	-
13	ENTER	INDEX	-	-	-	A/B/C/D/E	7A-12	7A-12	7A-12
14	>10	+10	-	-	79-8F	(VCR2)	7A-13	7A-56	-
15	CH+	CH+	-	-	-	PRESET+	7A-10	7A-10	7A-10
16	CH-	CH-	-	-	-	PRESER-	7A-11	7A-11	7A-11
17	REC	REC/PAUSE	7A-04	7F-04	79-AF	TEST	7A-85	7A-85	7A-85
18	DISPLAY	A/B DISPLAY	7A-06	7F-06	79-A5	ON SCREEN	7A-C2	7A-C2	7A-C2
19	PAUSE	PAUSE	-	-	79-A9	Up	7A-98	7A-98	7A-98
20	SKIP-	DIR A/SKIP-	7A-07	7F-07	79-AB	Left	7A-53	7A-53	7A-53
21	PLAY	PLAY	7A-00	7F-00	79-A8		-	-	-
22	SKIP+	DIR B/SLIP+	7A-40	7F-0B	79-AE	Right	7A-52	7A-52	7A-52
23	STOP	STOP	7A-03	7F-03	79-AA	Down	7A-99	7A-99	7A-99
24	REW	REW	7A-01	7F-01	79-AC	TIME/LEVEL	7A-86	7A-86	7A-86
25	FF	FF	7A-02	7F-02	79-AD	SET MENU	7A-9C	7A-9C	7A-9C
26	AV POWER	TAPE/MD POWER	-	-	-		-	-	-
27	TV POWER		Punch Through	Punch Through	Punch Through		Punch Through	Punch Through	Punch Through
28	STANDBY		Punch Through	Punch Through	Punch Through	AMP STANDBY	7A-1E	7A-1E	7A-1E
29	POWER		Punch Through	Punch Through	Punch Through	AMP POWER	7A-1D	7A-1D	7A-1D
30	TV VOL+		Punch Through	Punch Through	Punch Through		Punch Through	Punch Through	Punch Through
31	TV VOL-		Punch Through	Punch Through	Punch Through		Punch Through	Punch Through	Punch Through
32	TV INPUT		Punch Through	Punch Through	Punch Through		Punch Through	Punch Through	Punch Through
33	SLEEP		Punch Through	Punch Through	Punch Through	AMP SLEEP	7A-57	7A-57	7A-57
34	MUTE		Punch Through	Punch Through	Punch Through	AMP MUTE	7A-1C	7A-1C	7A-1C
35	VOL+		Punch Through	Punch Through	Punch Through	AMP VOL+	7A-1A	7A-1A	7A-1A
36	VOL-		Punch Through	Punch Through	Punch Through	AMP VOL-	7A-1B	7A-1B	7A-1B

- : No Code

**RX-V596/HTR-5250/RX-V596RDS**

---

**YAMAHA**

---