



IP210SS
Portable Ice Maker
Owner's Manual

This owner's manual provides instructions on safe installation, use, and maintenance. Please read it carefully and save it for reference.



<http://www.edgestar.com>

TABLE OF CONTENTS

IMPORTANT SAFETY INSTRUCTIONS	1
PREPARING YOUR ICE MAKER FOR USE	
IMPORTANT SAFETY TIPS.....	2
GETTING TO KNOW YOUR UNIT	3
OPERATING PROCEDURES & MAINTENANCE	
UNPACKING YOUR ICE MAKER	4
CONNECTING YOUR ICE MAKER.....	4
CLEANING AND MAINTAINING YOUR ICE MAKER.....	4
USING YOUR ICE MAKER	5
TROUBLESHOOTING.....	6
TECHNICAL SPECIFICATIONS & CIRCUIT DIAGRAM	8
WARRANTY	9

IMPORTANT SAFETY INSTRUCTIONS

Your safety and the safety of others are very important.

We have provided many important safety messages in this manual and on your appliance. Always read and obey all safety messages.

This is the safety alert symbol:



All safety messages will follow the safety alert symbol and the word “DANGER” or “WARNING”.



DANGER



WARNING

These words mean:

You can be killed or seriously injured if you don't immediately follow instructions.

All safety messages will tell you what the potential hazard is, tell you how to reduce the chance of injury, and tell you what can happen if the instructions are not followed.

PREPARING YOUR ICE MAKER FOR USE

IMPORTANT SAFETY TIPS

When using electrical appliances, basic safety precautions should be followed to reduce the risk of fire, electric shock, and/or injury to persons or property. Read all instructions before using any appliance.

- Do not operate this or any other appliance with a damaged cord. Connect to properly polarized outlets only. No other appliance should be plugged into the same outlet. Be sure that the plug is fully inserted into the receptacle.
- Do not run cord over carpeting or other heat insulators. Do not cover the cord. Keep cord away from traffic areas, and do not submerge in water.
- We do not recommend the use of an extension cord, as it may overheat and become a fire risk. If you must use an extension cord, use a cord of No.14 AWG minimum size and rated for no less than 1875 watts.
- Unplug the ice maker before cleaning it or making repairs.
- Exercise caution and use reasonable supervision when appliance is used near children.
- Do not clean your ice maker with flammable fluids. The fumes can create a fire hazard or explosion.
- Do not tip over.
- If the ice maker is brought in from outside in wintertime, give it a few hours to warm up to room temperature before plugging it in.

GETTING TO KNOW YOUR UNIT

1. Cover: Features a transparent window for interior visibility.
2. Ice shovel.
3. Control Panel: Easy to use, with touch controls.
 - A. Ice-full light.
 - B. Ice size indicators: Small, Medium, and Large.
 - C. Ice size selector button.
 - D. Add water light: when lit, add water.
 - E. Power indicator.
 - F. Power button.
4. Foot
5. Water drain cap: For draining water from water reservoir.
6. Air vent.

Note: Ice scoop not shown.



OPERATING PROCEDURES & MAINTENANCE

UNPACKING YOUR ICE MAKER

1. Remove the exterior and interior packaging. Check that ice basket and ice scoop is included. If any parts are missing, please contact customer service.
2. Clean the interior with lukewarm water and a soft cloth. Take out the ice basket and clean it .
3. Find a location for your ice maker that is protected from direct sunlight and other sources of heat (e.g., stove, furnace, radiator). Place the ice maker on a level surface. Make sure that there is at least 5 inches of space between the back and sides of your ice maker and the wall.
4. Allow one hour for the refrigerant fluid to settle before plugging ice maker in.
5. The appliance must be positioned so that the plug is accessible.

CONNECTING YOUR ICE MAKER



DANGER

*** Improper use of the grounded plug can result in the risk of electrical shock. If the power cord is damaged please call customer service.**

1. This unit should be properly grounded for your safety. The power cord of this appliance is equipped with a three-prong plug which mates with standard three prong wall outlets to minimize the possibility of electric shock.
2. Plug your appliance into an exclusive, properly installed, grounded wall outlet. Do not under any circumstances, cut or remove the third (ground) prong from the power cord. Any questions concerning power and/or grounding should be directed toward a certified electrician.
3. This appliance requires a standard 110~120 volt, 60Hz electrical outlet with three-prong ground.

CLEANING AND MAINTAINING YOUR ICE MAKER

Before using your ice maker, it is strongly recommended to clean it thoroughly.

1. Take out the ice basket.
2. Clean the interior with diluted detergent, warm water and a soft cloth.
3. The outside of the ice maker should be cleaned regularly with a mild detergent solution and warm water.
4. Dry the interior and exterior with a soft cloth.
5. When the machine is not in use, open the water drain cap to completely drain the water reservoir.

USING YOUR ICE MAKER

1. Select the size of the ice cube by pressing the “Select” button. If the room temperature is lower than 60°F, it is best to select the small or medium ice size, otherwise the ice cubes might stick together.
2. Open the cover, remove the ice basket and pour water into tank.
Keep water level below the level mark.
3. Press “Power” on the control panel to begin the ice making cycle.
4. The ice making cycle lasts 6 to 15 minutes, depending on the size of the ice cubes selected.
5. While the ice maker is on, verify the water level periodically. If the water level is too low, the ice maker will stop automatically, and the “Water” indicator will turn on.
Press the “Power” button, fill the unit with water, and press “Power” again.
Allow the refrigerant inside the compressor at least 3 minutes to settle before restarting.
6. The ice maker automatically stops working when the ice basket is full.
7. Change the water in the water reservoir every 24 hours to ensure a reasonable hygiene level.

If the ice maker will not be used for an extended period of time, you should drain the water from the reservoir and wipe out the inside of the unit.

TROUBLESHOOTING

Issue	Solution
<p>No power to the unit.</p>	<p>Check to make sure the power cord is plugged in</p>
	<p>Check the control panel for any lights or if there is any movement with any components of the unit such as the ice case or water pump. If there is no light or no movement, contact EdgeStar support.</p>
<p>Only the power and/or ice cube size lights are on, unit is not working and does not respond to buttons pushed on the control panel.</p>	<p>When the ice maker is plugged in, the power light may blink until you push the power button to turn on the unit.</p>
	<p>If you push the power button, but the unit does not respond, then the probable cause is a faulty control panel, and needs to be replaced. Contact EdgeStar support.</p>
<p>After pushing the power button and making ice cube selections, the ice maker does nothing.</p>	<p>Contact EdgeStar support.</p>
<p>Ice case moves back and forth but does not stop in the water fill position.</p>	<p>Contact EdgeStar support.</p>
<p>Unit goes through the ice making process, but no ice is produced, or ice cubes are very small.</p>	<p>Check to see if the ice maker is being used in proper ambient temperature. If unit is run in a room that is particularly hot at times, such as kitchen or laundry rooms, Please move the unit to a different, cooler room and try again.</p>
	<p>If ice maker is being used in proper ambient temperatures, then check to see if the fan on the side of the unit is working during the cycle. If not, then the fan needs to be replaced as it is not drawing the heat off the coils. Contact EdgeStar support.</p>
<p>Compressor makes a knocking noise</p>	<p>Make sure the unit is sitting level</p>
	<p>If the unit is sitting level, then contact EdgeStar support</p>
<p>When the unit tries to dump the ice, the ice case and shovel jam.</p>	<p>The ice case hinges or the ice shovel plastic tabs (on older models) are broken and need to be replaced.</p>

<p>The ice maker has a funny smell or the ice that is being produced has an unappealing taste.</p>	<p>Clean the machine out with a mild soapy solution and a soft cloth</p>
	<p>Add a tablespoon of vinegar to the water in the reservoir and then run a few batches of ice. After removing the vinegar ice and water, run a few more cycles with regular water. Remove this water and ice. The machine should then be free of a bad smell and you should be able to produce better tasting ice.</p>
<p>The “add water” light is on even though the machine is full of water.</p>	<p>Your water may not have enough impurities (distilled, reverse osmosis [RO], purified, etc.) in it. Add a pinch of salt to the distilled water. This will add impurities to the water which will allow the machine to detect the water.</p>
	<p>The water uptake filter may be clogged (at the bottom of the lower water reservoir). Using a flathead screwdriver to pry it out, clean the filter and replace.</p>
<p>Ice maker freezes one big block of ice instead of individual cubes.</p>	<p>If the ambient temperature in the room is less than 60 degrees, use only the small and medium ice cube size settings.</p>
	<p>If the ambient temperature in the room is normal, the compressor may be faulty. Contact EdgeStar support</p>
<p>The unit is leaking.</p>	<p>If there is a steady drip coming from the machine, the drain plug may be loose or a hose may have been damaged. If the drain plug is securely attached, contact EdgeStar support</p>
	<p>If the machine is leaking when water is poured into the lower water reservoir, a hose may have become dislodged. Contact EdgeStar support.</p>
<p>The evaporator coils are not freezing/The evaporator coils are not releasing the ice/Only half of the evaporator coils are freezing.</p>	<p>Contact EdgeStar support</p>

TECHNICAL SPECIFICATIONS & CIRCUIT DIAGRAM

TECHNICAL SPECIFICATIONS

Model	IP210SS
Power	115V/60Hz
Rated Current	2.7 A
Refrigerant	R134a/ 2.3 Oz
Net Weight	30 Lb
Size (HxWxD)	14 ¾" x 11 ¾" x 14 ½"

CIRCUIT DIAGRAM

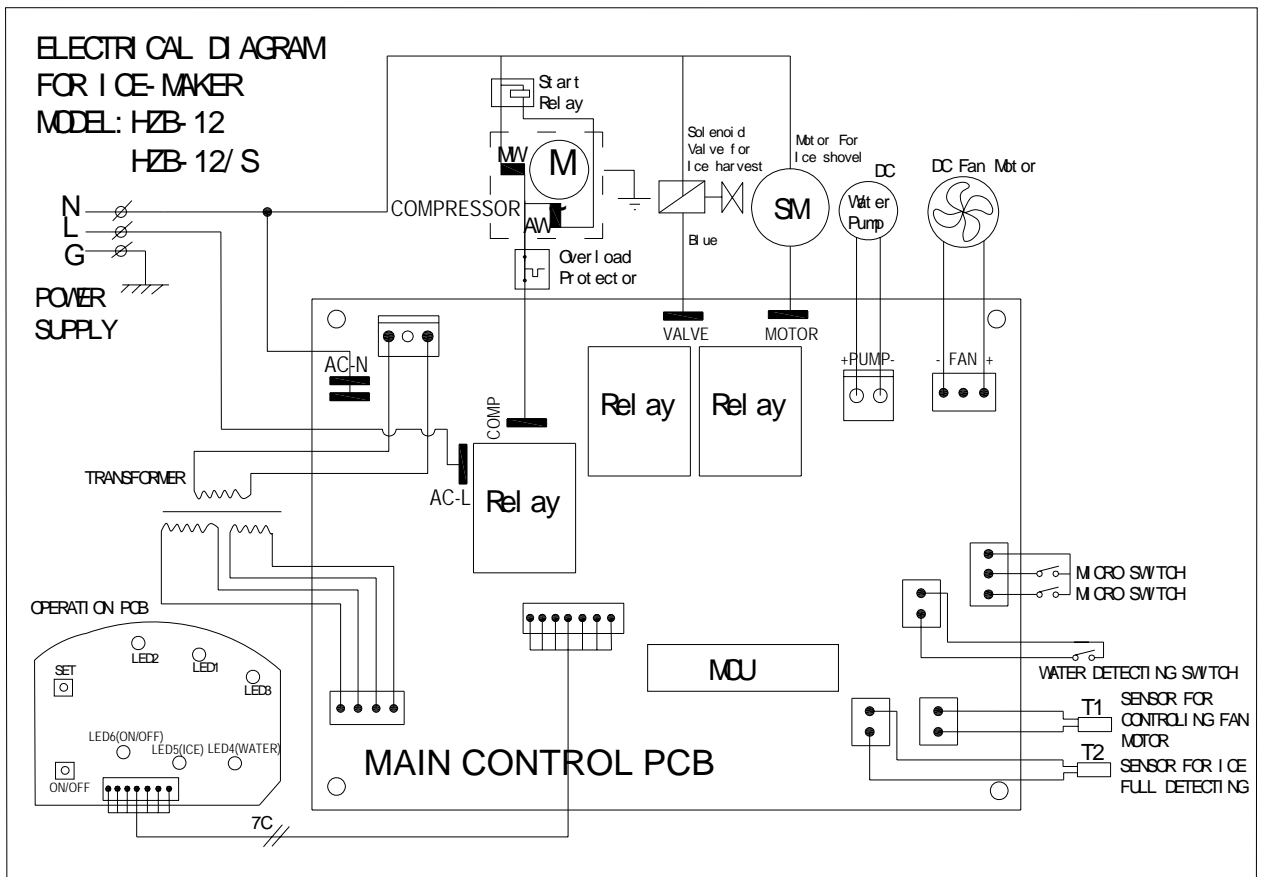

LIMITED WARRANTY

This EdgeStar product is warranted to be free from defective workmanship and materials for the first year following the date of original purchase. Replacement parts will be supplied free of charge for the first year following the date of original purchase. Labor will be performed free of charge for the first 90 days following the date of original purchase.

WHAT IS COVERED

This warranty applies to the original purchaser only, and only covers defects in workmanship experienced during operation of the product under normal service, maintenance, and usage conditions. This warranty applies to the purchase and use of this product in residential settings within the United States of America.

WHAT IS NOT COVERED

The following limitations apply to the coverage of this warranty:

Optional accessories, attachments, and appearance items are excluded from warranty coverage, as is shipping damage, and any damage caused by improper voltage or any other misuse, including abnormal service, handling, or usage.

This warranty does not cover normal wear and tear on parts or replacement of parts designed to be replaced, e.g. filters, etc.

This warranty does not cover service trips to deliver, pick-up, repair, or install the product, or to instruct in proper usage of the product.

Damages or operating problems resulting from abuse, operation outside environmental specifications, uses contrary to instructions provided in the owner's manual, accidents, vermin, fire, flood, improper installation, unauthorized service, acts of God, unauthorized installation or modification, or commercial use are excluded from warranty coverage.

Damage or loss of items stored inside the appliance are excluded from warranty coverage.

This warranty does not cover labor incurred 91 days or more after the date of original purchase.

This warranty does not cover use of EdgeStar products in commercial settings.

DESCRIPTION OF WARRANTY SERVICE

All defective product components covered by this warranty will be repaired or replaced, at EdgeStar's option, free of charge on a mail-in basis to EdgeStar's authorized repair facility during the first 90 days from the date of original purchase.

All defective product components covered by this warranty will be repaired or replaced, at EdgeStar's option, on a mail-in basis to EdgeStar's authorized repair facility during the time period beginning on the 91st day from the date of original purchase and ending one year from the date of original purchase. During this time period, parts will be supplied free of charge, but labor charges will apply.

All replacement parts and units will be new, remanufactured, or refurbished.

All products and components replaced by EdgeStar under warranty service become the

property of EdgeStar.

OBTAINING WARRANTY SERVICE

Contact EdgeStar for troubleshooting assistance and warranty service authorization at 1-866-319-5473. Please have your order receipt available to confirm the date of purchase.

Once an EdgeStar authorized representative has confirmed that your product is eligible for warranty service, the product must be returned to an EdgeStar authorized repair facility.

The purchaser is solely responsible for prepaying all shipping related costs to and from the repair facility.

EdgeStar is not responsible for damage resulting from shipper mishandling or improper packaging.

Do not return defective product to the place of purchase.

THIS WARRANTY IS IN LIEU OF ANY OTHER WARRANTY, EXPRESS OR IMPLIED, INCLUDING WITHOUT LIMITATION, ANY WARRANTY OF MERCHANTABILITY OR FITNESS FOR A PARTICULAR PURPOSE. TO THE EXTENT ANY IMPLIED WARRANTY IS REQUIRED BY LAW, IT IS LIMITED IN DURATION TO THE EXPRESS WARRANTY PERIOD ABOVE. NEITHER THE MANUFACTURER NOR ITS DISTRIBUTORS SHALL BE LIABLE FOR ANY INCIDENTAL, CONSEQUENTIAL, INDIRECT, SPECIAL, OR PUNITIVE DAMAGES OF ANY NATURE, INCLUDING WITHOUT LIMITATION, LOST REVENUES OR PROFITS, OR ANY OTHER DAMAGE WHETHER BASED IN CONTRACT, TORT, OR OTHERWISE. SOME STATES DO NOT ALLOW THE EXCLUSION OF INCIDENTAL OR CONSEQUENTIAL DAMAGES, SO THE ABOVE EXCLUSION MAY NOT APPLY TO YOU. THIS WARRANTY GIVES YOU SPECIFIC LEGAL RIGHTS. YOU MAY HAVE OTHER RIGHTS THAT VARY FROM STATE TO STATE.



For information on EdgeStar and to view our full line of products, please visit our website:

<http://www.edgestar.com>

EdgeStar Products

Box 81336

Austin, Texas 78708-1336

Toll Free: 1-866-319-5473