



AUTHORIZED TECHNICIAN

TECHNICAL MAINTENANCE MANUAL



CALYPSO FIRST STAGE

Contents

COPYRIGHT NOTICE.....	3
INTRODUCTION.....	3
WARNINGS, CAUTIONS, & NOTES.....	3
SCHEDULED SERVICE.....	3
GENERAL GUIDELINES.....	3
GENERAL CONVENTIONS.....	3
DISASSEMBLY PROCEDURES.....	4
REASSEMBLY PROCEDURES.....	5
FINAL TESTING.....	7
Checking Medium Pressure.....	7
Immersion Test.....	7
TABLE 1 - FIRST-STAGE TROUBLESHOOTING GUIDE.....	8
TABLE 2 - RECOMMENDED TOOL LIST.....	9
TABLE 3 - TORQUE SPECIFICATIONS.....	10
TABLE 4 -TEST BENCH SPECIFICATIONS.....	10
TABLE 5 - RECOMMENDED LUBRICANTS AND CLEANERS.....	11
PROCEDURE A - CLEANING AND LUBRICATION.....	12
EXPLODED PARTS DIAGRAM.....	14

Copyright Notice

This manual is copyrighted, all rights reserved. It may not, in whole or in part, be copied, photocopied, reproduced, translated or reduced to any electronic medium or machine-readable form without prior consent in writing from Aqua Lung America. It may not be distributed through the internet or computer bulletin board systems without prior consent in writing from Aqua Lung America.

©2007 Aqua Lung America, Inc.

Calypso First Stage Technical Maintenance Manual

Introduction

This manual provides factory prescribed procedures for the correct service and repair of the Aqua Lung® or Apeks regulator products described in this manual. It is not intended to be used as an instructional manual for untrained personnel.

The procedures outlined within this manual are to be performed only by personnel who have received Factory Authorized training through an Aqua Lung Service & Repair Seminar. If you do not completely understand all of the procedures outlined in this manual, contact Aqua Lung® to speak directly with a Technical Advisor before proceeding any further.

Warnings, Cautions, & Notes

Pay special attention to information provided in warnings, cautions and notes that are accompanied by one of these symbols:

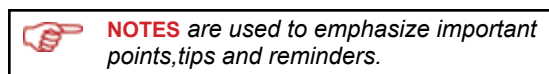
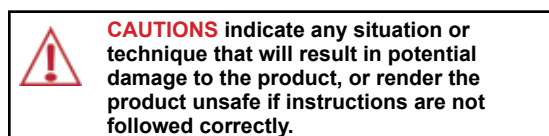
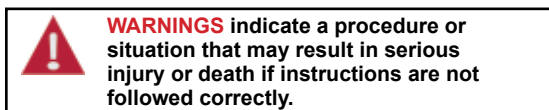

Scheduled Service

If the regulator is subjected to less than 50 dives per year, it is permissible to overhaul it every other year with an inspection procedure being performed on the "off" years. For example:

Year #1: Inspection

Year #2: Overhaul

Year #3: Inspection

Year #4: Overhaul, and so on.

Both Inspections and Overhauls need to be documented in the Annual Service & Inspection Record in the back of the Owner's Manual to keep the Limited Lifetime Warranty in effect. If a regulator is subjected to more than 50 dives per year, it should receive the complete overhaul.

An Official Inspection consists of:

1. A pressurized immersion test of the entire unit to check for air leakage.
2. Checking for stable intermediate pressure that is within the acceptable range.
3. Checking for opening effort that is within the acceptable range.
4. Checking for smooth operation of the control knob and venturi switch.
5. A visual inspection of the filter for debris or discoloration.
6. A visual inspection of the exhaust valve to see that it is in good shape and that it's resting against a clean surface.
7. A visual inspection of the mouthpiece looking for tears or holes.
8. Pulling back hose protectors and checking that the hoses are secure in the hose crimps.

If a regulator fails item #1,2,3 or 4, the entire regulator should be overhauled. If a regulator fails 4,5,6 or 7, it will be up to the technician's discretion whether or not a full overhaul is required.

General Guidelines

1. In order to correctly perform the procedures outlined in this manual, it is important to follow each step exactly in the order given. Read over the entire manual to become familiar with all procedures before attempting to disassemble the product in this manual, and to learn which specialty tools and replacement parts will be required. Keep the manual open beside you for reference while performing each procedure. Do not rely on memory.
2. All service and repair should be carried out in a work area specifically set up and equipped for the task. Adequate lighting, cleanliness, and easy access to all required tools are essential for an efficient repair facility.
3. As the regulator is disassembled, reusable components should be segregated and not allowed to intermix with nonreusable parts or parts from other units. Delicate parts, including inlet fittings and crowns which contain critical sealing surfaces, must be protected and isolated from other parts to prevent damage during the cleaning procedure.
4. Use only genuine Aqua Lung® parts provided in the overhaul parts kit for this product. DO NOT attempt to substitute an Aqua Lung® part with another manufacturer's, regardless of any similarity in shape or size.
5. Do not attempt to reuse mandatory replacement parts under any circumstances, regardless of the amount of use the product has received since it was manufactured or last serviced.
6. When reassembling, it is important to follow every torque specification prescribed in this manual, using a calibrated torque wrench. Most parts are made of either marine brass or plastic, and can be permanently damaged by undue stress.
7. In order to make the regulator compatible with nitrox up to 40%O₂ (EAN40), the regulator must be properly cleaned, lubricated and assembled using genuine Aqua Lung® or Apeks replacement parts. In addition, assembly must be carried out in a clean environment using powderless, latex gloves or equivalent. For more detailed information, be sure to read **Procedure A: Cleaning and Lubricating** at the back of this manual.

General Conventions

Unless otherwise instructed, the following terminology and techniques are assumed:

1. When instructed to *remove, unscrew, or loosen* a threaded part, turn the part counterclockwise.
2. When instructed to *install, screw in, or tighten* a threaded part, turn the part clockwise.
3. When instructed to *remove* an o-ring, use the pinch method (see illustration below) if possible, or use a brass or plastic o-ring removal tool. Avoid using hardened steel picks, as they may damage the o-ring sealing surface. All o-rings that are removed are discarded and replaced with brand new o-rings.

Pinch Method

Press upwards on sides of o-ring to create a protrusion. Grab o-ring or insert o-ring tool at protrusion.

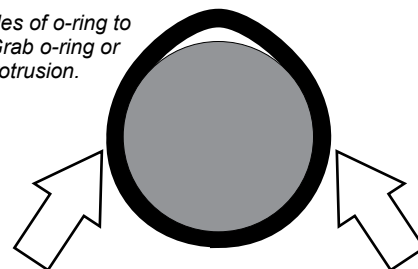

4. The following acronyms are used throughout the manual: **MP** is Medium Pressure; **HP** is High Pressure; **LP** is Low Pressure.
5. Numbers in parentheses reference the key numbers on the exploded parts schematics. **For example**, in the statement, "...remove the o-ring (7) from the crown (8)...", the number 7 is the key number to the crown o-ring.

DISASSEMBLY PROCEDURES

 **NOTE:** Before performing any disassembly, refer to the exploded parts drawing, which references all mandatory replacement parts. These parts should be replaced with new, and must not be reused under any circumstances regardless of the age of the regulator or how much use it has received since it was last serviced.

 **CAUTION:** Use only a plastic or brass o-ring removal tool (pn 944022) when removing o-rings to prevent damage to the sealing surface. Even a small scratch across an o-ring sealing surface could result in leakage. Once an o-ring sealing surface has been damaged, the part must be replaced with new. **DO NOT** use a dental pick, or any other steel instrument.

1. Pull back the hose protector to expose wrench flats. Using a 9/16" wrench, unscrew the MP hose from the first stage.

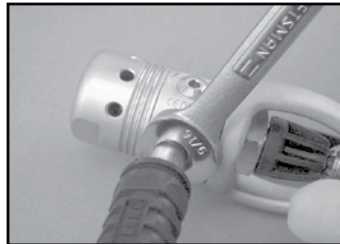
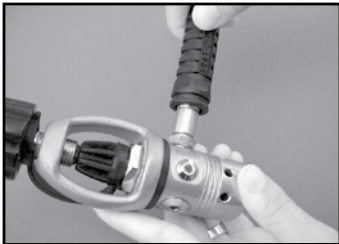

2. Using a 4mm hex key, unscrew the HP (19) and MP (10) port plugs. Remove the o-rings (9, 20) from the port plugs.

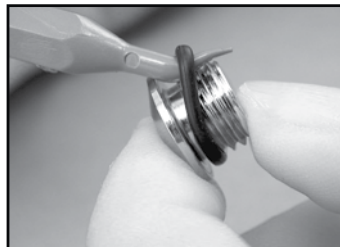

3. Remove the yoke screw (21) and dust cap (18). Thread a first stage vise mounting tool (pn 5116230) into the HP port.



4. Secure mounting tool in a vise. Using a large adjustable wrench, remove the inlet fitting (16) and the yoke (17). Remove the yoke washer (13).

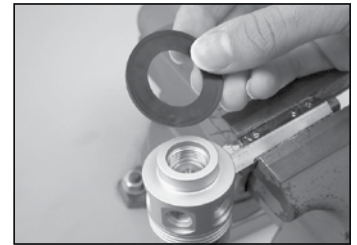
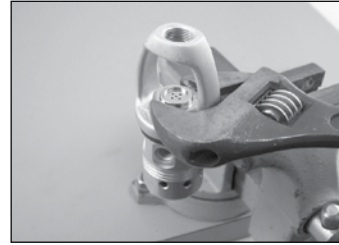

5. Remove the o-ring (15) from the inlet fitting (16). Insert the extraction tool (pn 109437) through the center hole of the inlet fitting and push out the conical filter (14).

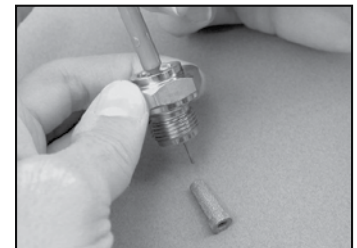

6. Remove the recessed o-ring (9) from the inside of the inlet fitting (16).



7. Turn the regulator in the vise so that the piston cap (2) is facing up. Using a large adjustable wrench, remove the piston cap. Remove the vise mounting tool.

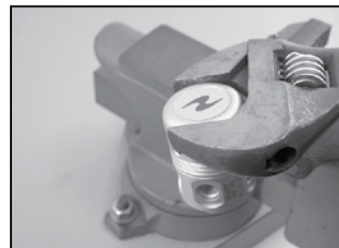

8. Insert the handle end of the extraction tool into the threaded end of the body (8) and push out the crown orifice (12). Remove the o-ring (11) from the crown orifice.

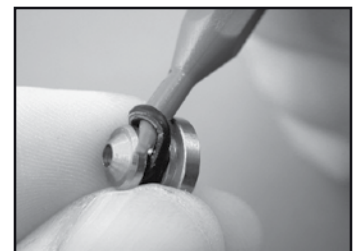
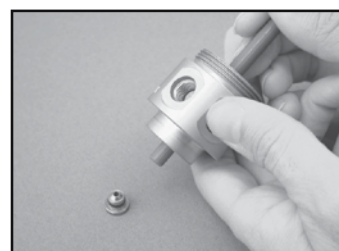

- Remove the main spring (7) from the piston cap (2). Firmly grasp the shaft of the piston (4) and directly pull it out of the cap.

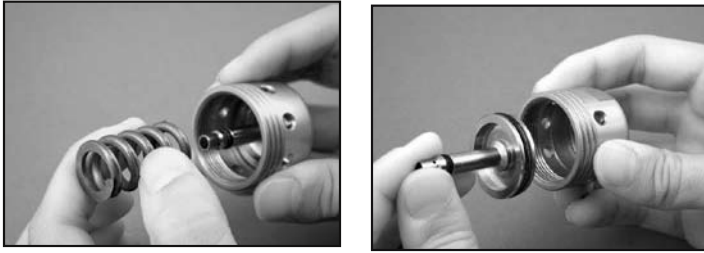

- Remove large piston head o-ring (3). Remove piston shaft o-ring (5).

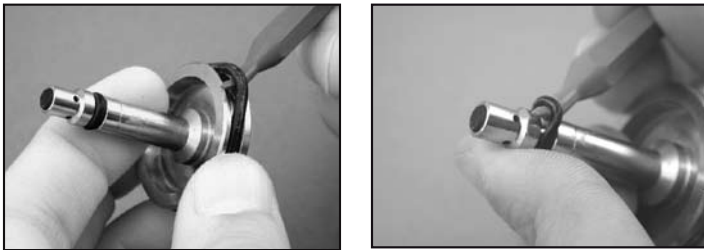

- Insert the extraction tool through the head of the piston (4) and push out the piston HP seat (6).



This Ends Disassembly.

Before starting reassembly, perform parts cleaning and lubrication in accordance with Procedure A : Cleaning and Lubricating, (p. 12).

REASSEMBLY PROCEDURES

- Place a new, lubricated o-ring (11) onto the crown orifice (12). Load the crown orifice onto the installation / extraction tool flat end first.

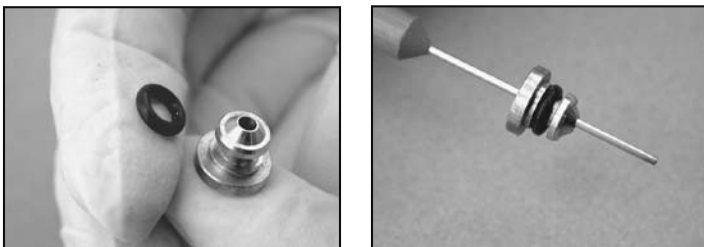

- Insert the crown orifice (12) into the inlet side (non-threaded side) of the body (8). Turn the tool over and press on the head of the crown orifice to confirm that it is seated all the way in the body.

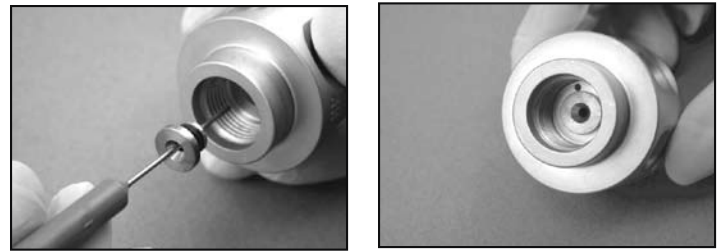

- Install a new, lubricated o-ring (5) into its groove on the piston (4) shaft.

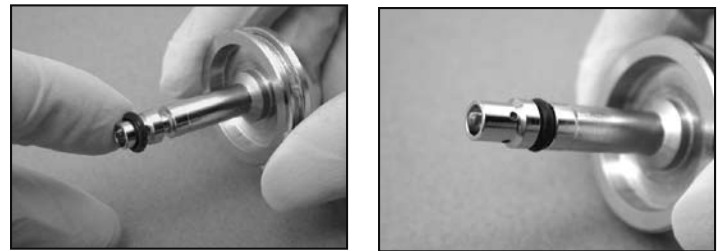

- Install a new, lubricated o-ring (3) onto the head of the piston (4).

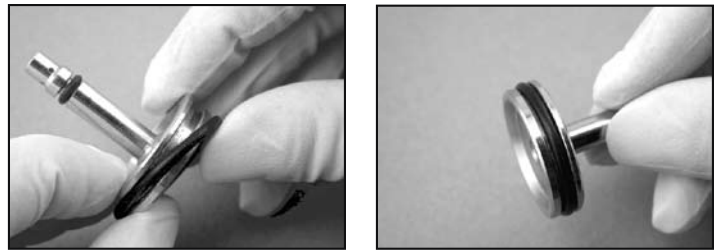

- Using your finger, press a new HP (6) seat into the end of the piston (4) until it is seated all the way and is flush with the end of the piston. If you are unable to press the HP seat into the piston all the way with your finger, as an option, you can place the HP seat on a clean surface and press the piston shaft over it.

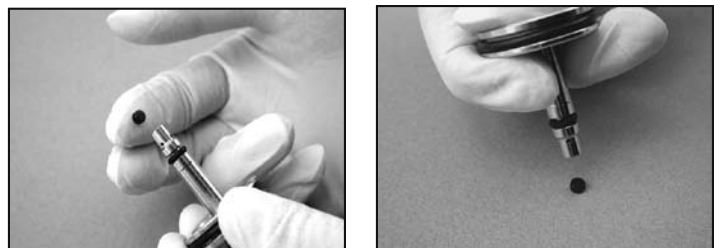

6. Apply a coat of Christo-Lube® to the outside of the piston head o-ring (3). Insert the piston (4), head first, into the cap (2).



7. Apply a coat of Christo-Lube® to the outside of the shaft o-ring (5). Lower main spring (7) over the shaft of the piston (4).

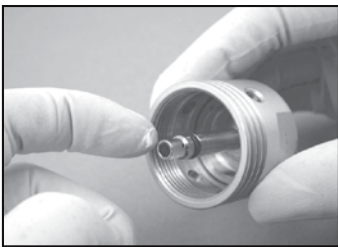

8. Apply a light coat of Christo-Lube® to the threads on the main body (8). Mate the piston cap assembly (2) to the main body. Thread until hand-tight.



9. Install a new, unlubricated o-ring (9) into the groove inside the inlet fitting (16).



10. Install a new, lubricated o-ring onto the outside of the inlet fitting (16). Using your finger, press fit a new conical filter (14), narrow end first, into the inlet fitting.

 **NOTE:** Be careful not to get any lubricant on or near the conical filter.

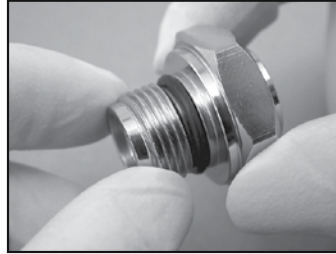

11. Load the body (8) into a vise using the vise-mounting tool. Using a large adjustable wrench, snug the cap (2) onto the body making sure that metal meets metal.

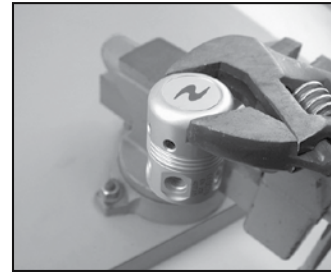

12. Invert the body (8) in vise. Install the cosmetic black washer (13), smooth side up, onto the body. Set the yoke (17) on top of the washer.

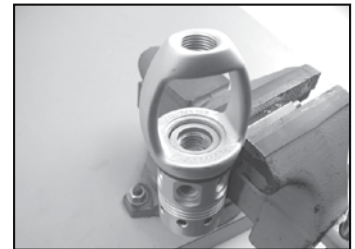
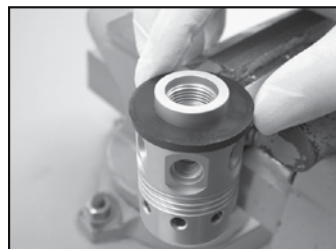

13. Thread in the inlet fitting (16). Using a ft/lbs torque wrench, the inlet fitting socket (pn 111001) and a 3" extension, apply a torque of 18 ft/lbs / 24.5 Nm to the inlet fitting. Install dust cap (18) and yoke screw (21).



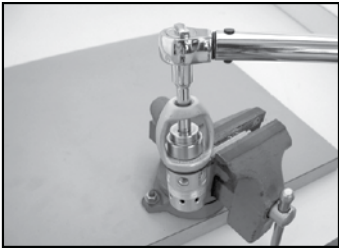

14. Install o-rings (9, 20) onto each port plug (10, 19). Using a 4mm hex key, install each of the port plugs into its respective port.

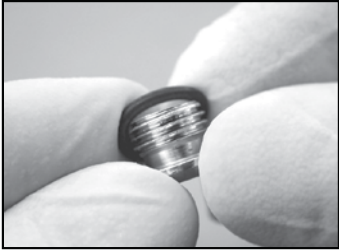

15. Install the MP hose into its respective port. Using an in/lbs torque wrench and a 9/16" crow foot, torque the hose to 40 in/lbs / 4.5 Nm.

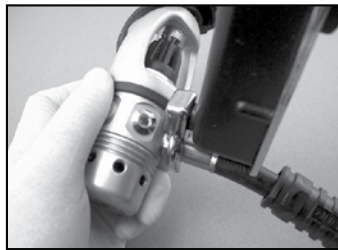
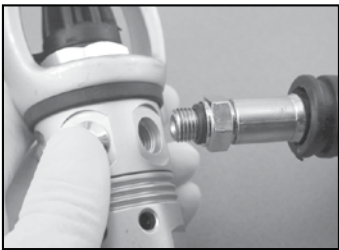

16. Slide hose protector back into position.



This Concludes Reassembly

FINAL TESTING

CHECKING THE MEDIUM PRESSURE

1. Attach an MP test gauge (0-400 psig or 0-27 bar) to a MP hose and thread the hose into the open MP port. If your test gauge does not have an over-pressure relief valve, you must also attach a properly adjusted second stage to the first stage to act as the relief valve in case of a HP leak.
2. Attach the first stage to a cylinder charged to 3000 psi (206 bar). Slowly open the cylinder valve to pressurize the regulator.

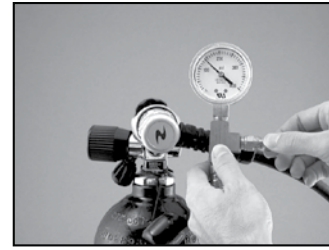

WARNING: If the pressure gauge rapidly exceeds 145 psi (10 bar), then there is a HP leak. Quickly close the cylinder valve and purge the regulator. Failure to do so may cause a rupture to the MP hose and/or the MP gauge which in turn, can lead to personal injury. Refer to *Table 1, Troubleshooting Guide*, for the causes of HP leaks.

3. With the regulator under pressure, cycle the over-pressure relief valve or the second stage purge button to produce an airflow.
4. Check the MP reading, which should be between 130 and 145 psi (9-10 bar).
5. Leave the regulator under pressure for about 10 seconds - the MP should remain stable and should not rise by more than 5 psi (.35 bar). If the MP rises more than 5 psi (.35 bar), this indicates that there is a leak. Refer to *Table 1, Troubleshooting Guide*.

IMMERSION TEST

With the port plugs and at least one properly adjusted second stage installed, slowly open the cylinder valve and pressurize the first stage. Completely submerge the first stage in fresh water and check for leaks.



NOTE: Do not confuse bubbles from trapped air with a true leak. If there is an air leak, bubbles will come out in a constant stream.

Assuming there are no leaks, close the cylinder valve and depressurize the regulator. Remove the first stage from the valve and secure the dust cap in place with the yoke screw. If a leak is detected, note the source of the leak and refer to *Table 1, Troubleshooting Guide* for possible causes and corrective actions.

Table 1 - Troubleshooting Guide

SYMPTOM	POSSIBLE CAUSE	TREATMENT
Restricted airflow/high inhalation resistance through entire system	1. Cylinder valve not completely opened.	1. Open valve. Check fill pressure
	2. Cylinder valve requires service	2. Connect to a different cylinder
	3. Conical filter (14) contaminated	3. Replace filter with new
	4. Insufficient medium pressure	4. See below
Insufficient medium pressure	1. Low inlet pressure	1. Refill test cylinder
	2. Main spring (7) weakened	2. Replace main spring
High intermediate pressure (leakage or freeflow through second stage)	1. HP seat (6) damaged or worn	1. Replace HP seat
	2. Piston o-rings (3,5) damaged and worn	2. Replace o-rings
	3. Crown o-ring (11) damaged	3. Replace o-ring
	4. Crown orifice (12) sealing surface damaged	4. Replace crown
	5. Damaged piston (4)	5. Replace piston
Leakage of air from ambient ports of piston cap	1. Piston shaft o-ring (5) damaged or worn	1. Replace o-ring
	2. Piston head o-ring (3) damaged or worn	2. Replace o-ring
Leakage of air from inlet fitting	1. Inlet fitting o-ring (15) damaged	1. Replace o-ring



NOTE: This is a partial list of possible problems and recommended treatments. For more information, contact Aqua Lung's Technical Services Department for assistance with problems not described here.



CAUTION: Recommended treatments which require disassembly of the regulator must be performed during a complete overhaul, according to the prescribed procedures for scheduled, annual service. Do not attempt to perform partial service.

Table 2 - Recommended Tool List









PART #	DESCRIPTION	APPLICATION
111610	MP Gauge 0-400 psi (0-27 bar) 	Checking medium pressure
944022	O-ring Tool 	Removing and installation of o-rings
111001	Inlet Fitting Socket 	Apply proper torque to inlet fitting
N/A	3" Socket Extension 	Use with inlet fitting and spring retainer sockets to apply proper torque
109437	Seat Extraction Tool 	Crown (14) assembly/disassembly
5116230	Vise Mounting Tool 	For holding first stage in vise
N/A	Torque Wrench ft/lbs and in/lbs	Apply torque to parts listed in Table 3: Torque Specification, p. 10
N/A	Hex Key (4mm) 	Loosen/tighten/adjust parts
N/A	Hex Key Adapter (4mm) 	Apply torque to parts listed in Table 3: Torque Specification, p. 10
N/A	Open-end Wrench (1/2", 9/16", 5/8") 	Loosen/tighten/adjust parts
N/A	15" Adjustable Wrench	Loosen parts
N/A	Crowfoot (26mm) (1/2", 9/16", 5/8") 	Apply torque to parts listed in Table 3: Torque Specification, p. 10
N/A	Magnifier w/Illumination	Sealing surface and spring inspection
N/A	Ultrasonic Cleaner	Brass & stainless steel parts cleaning
N/A	Bench Vise	Disassembly / Reassembly
N/A	Powderless latex gloves or finger cots	Keep finger oils off of parts
900015	Service Kit CALYPSO	

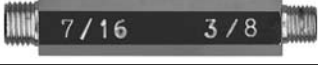

Table 3 - Torque Specifications

PART #	DESCRIPTION / KEY ITEM #	TORQUE
125712	Piston Cap / 2	18 ft/lbs / 24.5 Nm
125716	Inlet Fitting / 16	18 ft/lbs / 24.5 Nm
103133	MP Port Plug / 10	40 in/lbs / 4.5 Nm
103137	HP Port Plug / 19	40 in/lbs / 4.5 Nm
APF124563	Interstage Hose	40 in/lbs / 4.5 Nm

Table 4 - Test Bench Specifications

TEST	CONDITION	SPECIFICATIONS
Immersion Test	Supply Pressure 2500 - 3000 psi (176-206 bar)	No leaks
Medium Pressure	Supply Pressure 2500 - 3000 psi (176-206 bar)	MP at 130 - 145 psi (9-10 bar)
MP Variation	Supply Pressure 2500 - 3000 psi (176-206 bar)	After cycling the regulator several times, the MP should not increase by more than 5 psi in 5 - 15 seconds.

Table 5 - Recommended Lubricants & Cleaners

LUBRICANT / CLEANER	APPLICATION	SOURCE
Christo-Lube® MCG-111	All O-rings seals	Aqua Lung, PN 820466, or Lubrication Technologies 310 Morton Street Jackson, OH 45640 (800) 477-8704
<div style="border: 1px solid black; padding: 5px;">  CAUTION: Silicone rubber requires no lubrication or preservative treatment. DO NOT apply grease or spray to silicone rubber parts. Doing so may cause a chemical breakdown and premature deterioration of the material. </div>		
Oakite #31	Acid bath for reusable stainless steel and brass parts.	Oakite Products, Inc. 50 Valley Road Berkeley Heights, NJ 07922
White distilled vinegar	Acid bath for reusable stainless steel and brass parts.	“Household” grade
<div style="border: 1px solid black; padding: 5px;">  CAUTION: Do not use muriatic acid for the cleaning of any parts. Even if strongly diluted, muriatic acid can harm chrome plating and may leave a residue that is harmful to O-ring seals and other parts. </div>		
Liquid dishwashing detergent (diluted with warm water)	Degreaser for brass and stainless steel parts; general cleaning solution for plastic and rubber	“Household” grade

Procedure A

Cleaning & Lubrication

Aqua Lung® and Apeks First Stages and Nitrox

When it comes to issues of nitrox safety and compatibility, the concerns lie primarily with the first stage as it is subjected to high inlet pressures. High inlet pressures lead to adiabatic compression or heating of the gas. The Aqua Lung® or Apeks regulator product described in this manual, when properly cleaned and assembled, is authorized for use with enriched air nitrox (EAN) that does not exceed 40% (EAN 40). It is authorized because it has undergone adiabatic compression testing and the authorized service kit components and lubricants are compatible in elevated oxygen environments. During cleaning, a mild detergent must be used to remove condensed hydrocarbons (compressor oils) from the inside passageways of the first stage. For the first stage to remain EAN40 compatible, only use hyper filtered compressed gas (hydrocarbons < 0.1 mg/m³). Ordinary compressed breathing air (Grade E) usually does not meet this criterion. Once ordinary breathing air is used, the first stage is no longer EAN40 compatible until it is cleaned and serviced again.

Although regulator second stage components are not exposed to high pressure EAN, Aqua Lung® recommends that the same cleaning procedures be followed for the complete regulator. This prevents the possibility of cross contamination and guarantees the cleanliness of the entire regulator.

Cleaning Brass and Stainless Steel Parts

1. Preclean in warm, soapy water* using a nylon bristle tooth brush.
2. Thoroughly clean parts in an ultrasonic cleaner filled with soapy water. If there are stubborn deposits, household white distilled vinegar (acetic acid) in an ultrasonic cleaner will work well. DO NOT place plastic, rubber, silicone or anodized aluminum parts in vinegar.
3. Remove parts from the ultrasonic cleaner and rinse with fresh water. If tap water is extremely "hard," place the parts in a bath of distilled water to prevent any mineral residue. Agitate lightly, and allow to soak for 5-10 minutes. Remove and blow dry with low pressure (25 psi) filtered air, and inspect closely to ensure proper cleaning and like-new condition.

Cleaning Anodized Aluminum, Plastic & Rubber Parts

Anodized aluminum parts and parts made of plastic or rubber, such as box bottoms, box tops, dust caps, etc., may be soaked and cleaned in a solution of warm water mixed with mild dish soap. Use only a soft nylon toothbrush to scrub away any deposits. Rinse in fresh water and thoroughly blow dry, using low pressure filtered air.



CAUTION: Do not place plastic and rubber parts in acid solutions. Doing so may alter the physical properties of the component, causing it to prematurely degrade and/or break.

Cleaning Hoses

1. Hose fittings: Ultrasonically clean with soapy water*; vinegar OK on tough corrosion
2. Run soapy water through hose if needed
3. Thoroughly rinse with fresh water
4. Blow out hose before installing

Lubrication and Dressing

Wear powderless, latex gloves when handling and lubricating o-rings. Keeping internal parts free from skin oils and other contaminants is important when running enriched air nitrox through a first stage. All o-rings should be lubricated with Christo-Lube® MCG-111. Dress the o-rings with a very light film of grease, and remove any visible excess by running the o-ring between thumb and forefinger. Avoid applying excessive amounts of Christo-Lube® grease, as this will attract particulate matter that may cause damage to the o-ring.

*Soapy water is defined as "household" grade liquid dishwashing detergent diluted in warm water.



NOTES

Calypso First Stage • Exploded Parts Diagram

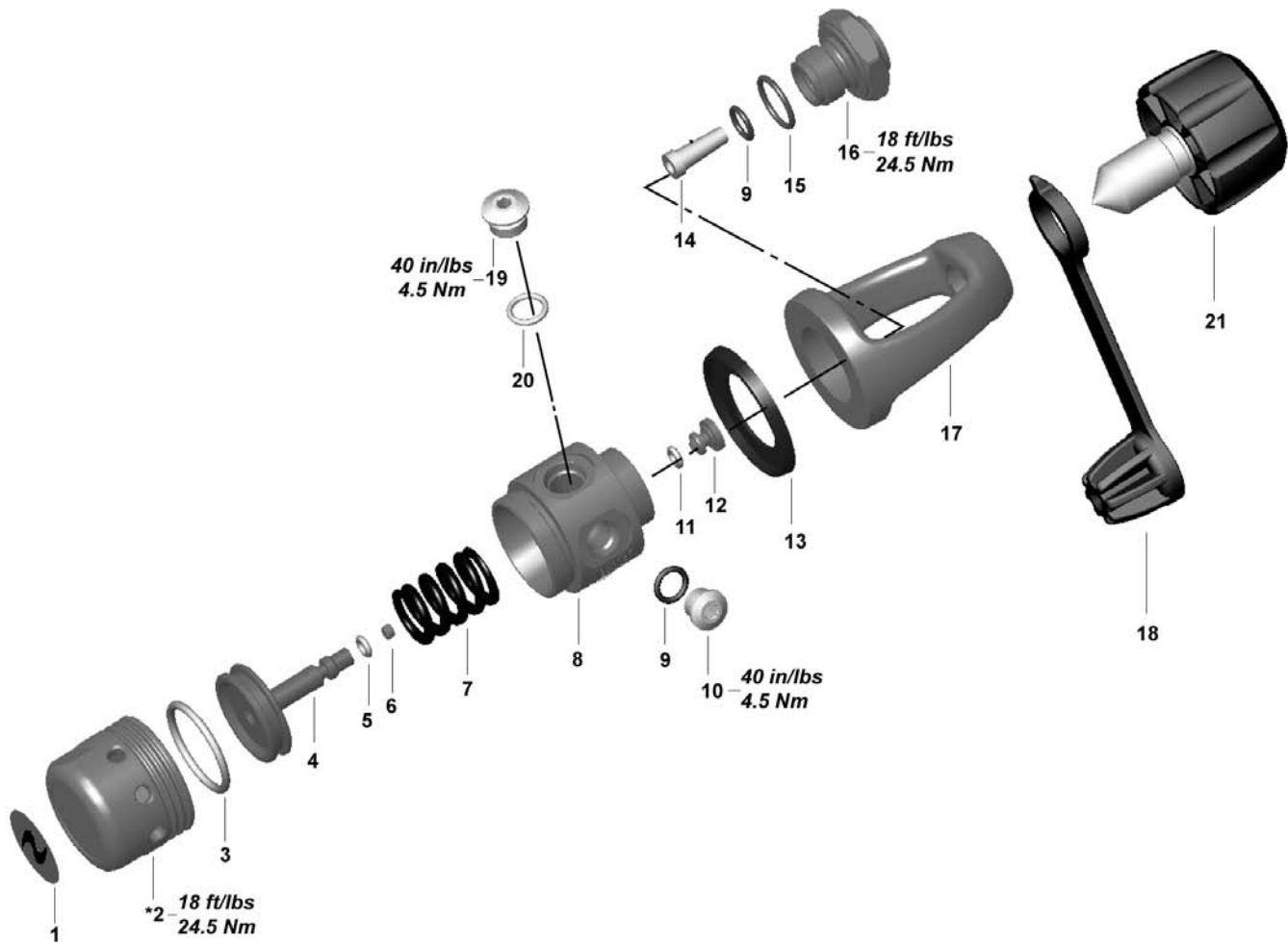

Key #	Part #	Description
-----	125730	First Stage, Calypso, Yoke
-----	900015	Overhaul Parts Kit
1-----	125713	Decal, Aqua Lung logo
2-----	125712	Piston cap
3-----	820062	O-ring
4-----	125717	Piston
5-----	820007	O-ring
6-----	106726	HP seat
7-----	106771	Spring
8-----	124628	Body
9-----	820011	O-ring
10-----	103133	MP port plug
11-----	820007	O-ring
12-----	106767	Crown orifice
13-----	125710	Yoke washer
14-----	129151	Filter
15-----	820015	O-ring
16-----	125716	Inlet fitting
17-----	106843	Yoke, satin
-----	124611	Yoke, bright Chrome
18-----	124555	Dust cap
19-----	103137	HP port plug
20-----	957004	O-ring
21-----	107507	Yoke screw
-----	107508	Yoke screw, green, Nitrox, O ₂

Part numbers in **BOLD ITALICS** are included in the service kit.



Authorized Technician

**TECHNICAL MAINTENANCE MANUAL
CALYPSO FIRST STAGE**

Aqua Lung America
2340 Cousteau Court, Vista CA 92081
Tel: 760-597-5000 / Web: www.aqualung.com

©2007 Aqua Lung International

Rev 06/07