

GB

*Induction hob operating and
installation guide*

ref. manufacturer **214**

9963 3131 02/04

List of contents

Using your hob in complete safety.....	3
Containers.....	6
Installing your hob in complete safety.....	7
Using your hob in all simplicity.....	9
Preserving and maintaining your hob.....	10
Cooking	12

In this Manual,

 *displays safety instructions*

 *displays tips and hints*

Using your hob in complete safety

For saucepans

Overheat sensor

- Each unit is equipped with a sensor that continuously monitors the temperature of the bottom of the pan, so that overheating is impossible (empty saucepan, etc.).
- A sensor continuously monitors the temperature of the components of your hob. The power output by the hob will automatically be reduced if this temperature becomes excessive.

For the hob

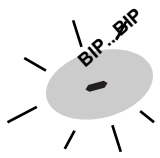

Overflow protection

The shutdown of the hob, a special display (symbol shown opposite) and an audible "beep"* can all be triggered in one of the three following cases:

- An overflow which covers the control buttons.
- A damp cloth being placed on the buttons.
- A metal object being placed on the control buttons.

Clean or remove the object and start cooking once again.

* depending on the model

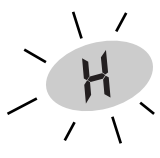

Residual heat indicator

After intensive use, the cooking zone may remain hot for several minutes.

The letter "H" is displayed during this period. Do not touch the zones concerned.

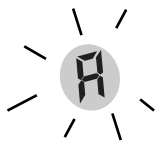

Auto-stop system

The "Automatic-Stop" function activates automatically if the user forgets to turn off the cooker after cooking.

It starts up automatically if ever you forget to turn off after cooking

The letter **A** is displayed for the heating zone concerned and the hob will bleep for about 2 minutes. The **A** will continue to be displayed until any control of the zone in question is touched. The hob will then bleep twice to confirm your action.

Power used	the heating zone goes out automatically after:
Between 1...4	8 hours
Between 5...7	2 hours
Between 8...9	1 hour

Using your hob in all simplicity



Child safety

Your cook top is equipped with a **child safety feature** which locks it during the use:

- Either when stopped (for cleaning)
 - Or during cooking (any operations underway will continue and the displayed settings remain active).
- this case, for safety reasons only the **"STOP"** button is still usable.

Don't forget to unlock the appliance before reusing it.

Locking the appliance

- Identify the special locking buttons **(- +)** placed on top of a symbol representing a padlock (or a key).
- Press simultaneously on these buttons **(- +)** until the following information is displayed  or 

The display goes out after a few seconds.

Pressing any of the buttons activates the display.

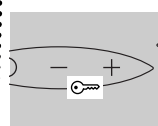

Unlocking the appliance

Press simultaneously on the locking buttons **(- +)** until the display goes out.

Automatic saucepan detection

Your induction hob is able to recognise most recipients.

- Test recipient: place your recipient on one of the rings on power setting **4**.

If the display remains unchanged, your recipient is compatible.

If it flashes on and off, your recipient cannot be used with induction.

- You can also check using a magnet.

If it "sticks" to the base of the recipient, then this recipient is compatible with induction.

Removing the recipient from the hob immediately turns off the power to your hob. To completely turn off the ring you should press on the "Stop" button.

"Small item" safety feature

A small object such as a fork, spoon or a ring placed on your induction hob by itself is not detected as a pan. The display flashes and there is no output power.

Your induction hob in complete safety

The principles of induction

When your induction hob is switched on and a heating power has been selected, the electronic circuits produce induced currents that instantaneously heat the bottom of the pan that transfers this heat to the food.

Thus cooking takes place with **practically no energy loss** between the induction hob and the food.

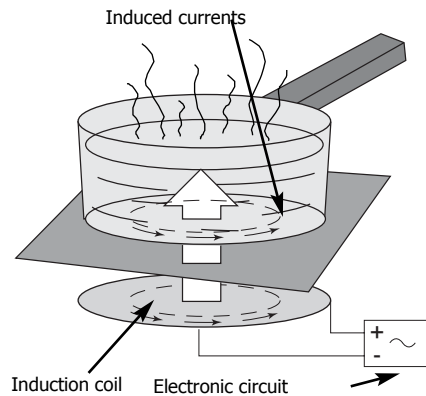

For the attention of wearers of pacemakers or other active implants:

The hob complies with all current standards on electromagnetic interference.

Your induction hob is therefore perfectly in keeping with legal requirements (89/336/CEE directives). It is designed not to create interference on any other electrical apparatus being used on condition that the apparatus in question also complies with this legislation.

Your induction hob generates short-range magnetic fields.

To avoid any interference between your induction hob and a pacemaker, the latter must be designed to comply with relevant regulations.

In this respect, we can only guarantee our own product conformity. Please consult the pacemaker manufacturer or your doctor concerning its conformity or any possible incompatibility.



If a crack appears in the glass surface, disconnect the appliance immediately to avoid any risk of electric shock. For disconnecting, remove the fuses or use the cutout switch.

Do not re-use your hob until the glass surface has been changed.



Your hob must never be used as a storage space or cutting surface for any products whatsoever.

When cooking never use aluminium foil and never place products wrapped in aluminium foil or products deep-frozen in aluminium packs on the hob.

The aluminium will melt and damage your appliance irreparably.



Do not leave empty pans on your hob in case of residual heat or if the hob is turned on by mistake.

A steam cleaner must not be used.

containers

You probably already have some suitable pans.

Your induction hob is able to recognize most types of pans.

Pan test: Place your pan on a zone, for example at

position 4; you know that your pan is compatible if the display does not flash, but if it does flash then you cannot use this pan for induction cooking. You can also test it with a magnet: if the magnet "sticks" to the base of the pan, then you can use it for induction cooking.

Pans compatible with induction are:

- pans made of enamel coated steel with or without a non-stick coating.
- cast iron pans with or without enamel coated base.

An enamelled coated base will prevent the glass top of your hob from getting scratched.

- stainless steel pans designed for induction cooking.

Most stainless steel pans (saucepans, stewpans, frying pans, deep frying pans, etc.) are suitable for induction cooking if they pass the pan test.

- aluminium pans with special base. pans which do not have a flat base may be suitable, however they must not be deformed too badly.

Choose a pan marked with the  logo on its base or packaging to be sure that it is perfectly suitable for use on your induction hob under normal conditions of use.

Note

Glass, ceramic, earthenware pans, aluminium pans (without a special base) and copper pans, and some non-magnetic stainless steel pans are incompatible with induction cooking. You will be informed by the flashing display.

You should choose pans with a thick flat base for uniform cooking (heat is better distributed).

Using the cooking zones according to the pan

Multi-service zone

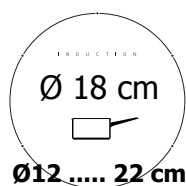

Installing your hob in complete safety

Always ensure that the air vents beneath the hob are kept clear.
Your induction hob must always be adequately ventilated.

Above a cupboard or drawer unit

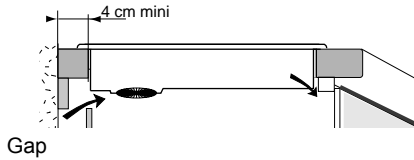

 During long cooking sessions, leave the drawer slightly open to promote the circulation of warm air.

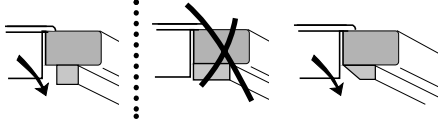

Ensure that the unit crossbar does not block the air passage, make a bevel if necessary.

Above an oven

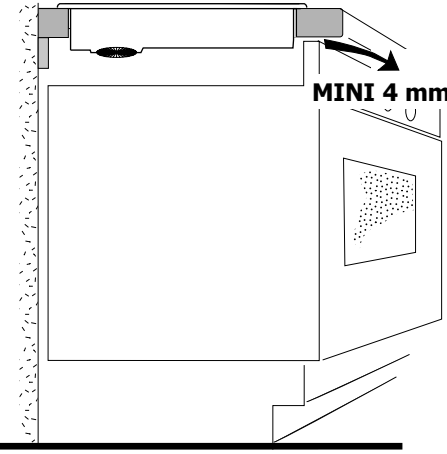

If the appliance underneath your hob produces excess heat :

this will be detected by a safety device incorporated into your induction hob. A high temperature will be indicated by a **series of dashes** or **F7** will appear in the display.

If this happens we suggest you either create an opening in the side of the unit and/or install an insulation kit available from the After-Sales Dept (ref 75X1652), which will protect your hob from the heat generated beneath it.

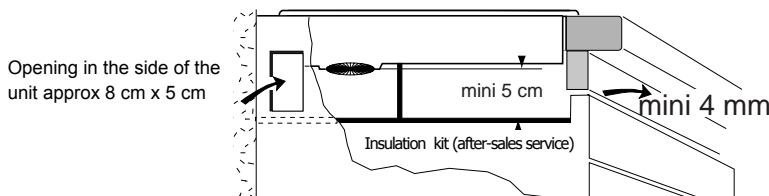

Providing the advice on ventilation given above is followed, your hob can be installed above any piece of kitchen equipment.

Installing your hob in complete safety

Fitting

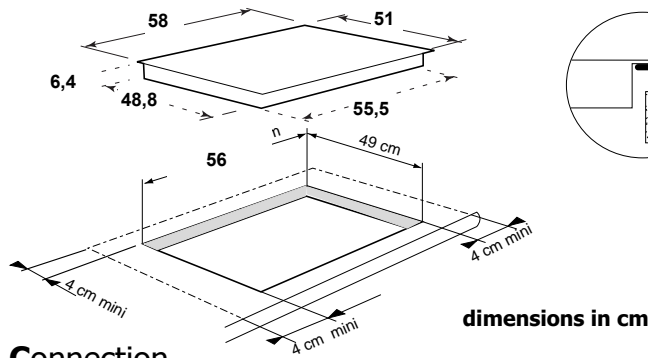

A seal exists for preventing any humidity getting under the hob.
 -Stick the seal under the rim of the hob and lower the hob into position on the worktop.
 -This seal is supplied in the sachet; stick it in place beneath the hob.

Connection

These hobs are delivered with type H 05 VVF power cable (1.5mm²) with 3/5 conductors (including a green/yellow earth wire), which must be connected to the power supply via a plug that complies with publication CEI 60 083 or an all-pole cut-out unit with contacts that open by at least 3mm.

If the cable is damaged, it must be replaced by the manufacturers, their After Sales Service or another similarly qualified person for avoiding any possible risk of accident.

When the power is switched on, or after a long power failure, a light code appears on the control panel. This disappears automatically after about 30 seconds or as soon as any touch control is touched on the panel. This is normal, as the display is for use by the after-sales service when required. The user must not take this into account under any circumstances. If the unit has a 3 phase 400 V2N connection, and is not working correctly, check that the neutral wire is correctly connected. This precaution should also be taken for all your other electronic apparatus.

"When installing the hob, precautions must be taken to avoid damaging the power cable with the sharp edges".

- 220 240V monophase fuse 32 Amp

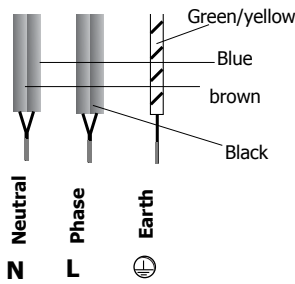

5,6 kW

The unit must be installed so that the mains plug is easily accessible.

- 400 V 2N three-phase fuse : 16 Amp

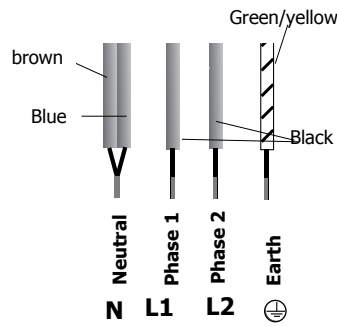

Separate the 2 phase wires L1 and L2 before connecting

Using your hob in all simplicity

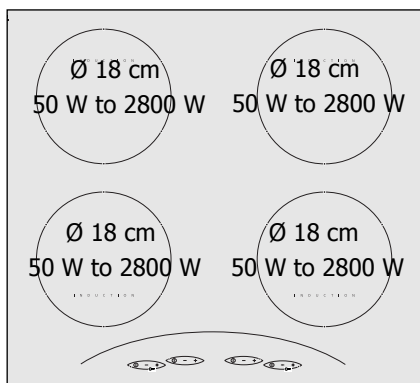

Start/Stop

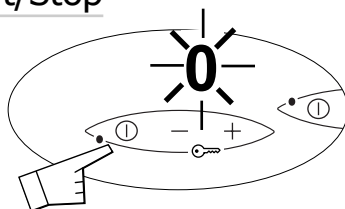

A flashing **0** show that the zone concerned has been turned on.
You can then choose the desired power.
If you do not set the power, the cooking zone will turn itself off automatically.

Setting manual power

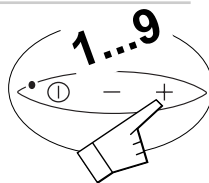

Preserving and maintaining your hob

● You must:

Avoid any shocks with pans:

The glass surface is highly resistant but not unbreakable.

Avoid rubbing with any abrasive or with the base of pans etc. as in time this will deteriorate the markings on the top of your ceramic hob.

Avoid using pans with rough or dented bases:

They may hold and transport matter liable to stain or scratch the hob.

Any such faults, which are not the cause of breakdowns nor make the hob impossible to use, are not included in the guarantee conditions.

Place your pan **in the middle** of the heating zone.

● You must not

Leave metal cooking utensils, knives and forks, or metal objects on the hob. They will get hot if left close to any heating zone that is in use.

Store MAINTENANCE or INFLAMMABLE products in the cupboard under your hob.

Leave an empty pan on a heating zone.





Heat up a closed can. It may burst; this recommendation applies to all methods of cooking.

Put the pans on the frame or plate (depending on the model)

Preheat at maximum temperature when using pans with non-stick inside surfaces (Teflon type). Use very little or no fat at all.

The maximum heating position is for boiling and frying only.

It is very easy to clean your countertop hob, especially if you follow these few recommendations:

TYPE OF STAIN	WHAT TO DO	ACCESSORIES EMPLOYED
Minor	Soak the area to be cleaned with hot water, then wipe it.	Clean sponges
Accumulated burnt-on stains	Soak the area to be cleaned with hot water, use a special ceramic hob scraper to remove the worst, finish off with the rough side of a cleaning sponge, then wipe it clean.	Clean sponges special ceramic hob scraper
Rings and traces of limescale	Apply hot white spirit vinegar on the stain, leave to act then wipe off with a soft cloth.- Use a commercial cleaner.	Special ceramic hob cleaner
Burnt-on stains following sugar spillage, melted aluminium or plastic.	- Apply a special ceramic hob cleaner on the surface, preferably one which contains silicone (protective action).	Special ceramic hob cleaner
 powder	 abrasive-backed sponge	 cream
		 ordinary sponge or special sponge for delicate items

Minor troubleshooting

You have doubts about whether your hob is working correctly this does not necessarily mean there is a breakdown. Nevertheless, check the following points

IF YOU REALIZE THAT	POSSIBLE CAUSES	WHAT SHOULD YOU DO?
When you switch on, the display lights up	The hob is working normally	NOTHING: see chapter Remarks on connections
When you switch on, the fuse blows	Your hob is connected incorrectly	Check the connection and make sure it complies with requirements.
When you switch on, only one side of the hob works	Your hob is connected incorrectly	
The fan keeps going for a few minutes after the hob has been switched off	The electronics are cooling down	This is normal.
The top of the hob is always warm (even when it is switched off).	The electronics are under power as for all other electronic apparatus (TV, transformers, etc.).	This is normal.
The hob does not work. Displays on the keyboard do not come on	The apparatus is not under power. There is a power or connection problem.	Inspect the fuses and the cut-out switch.
The hob stops working during operation, a  , or F7 come on.	Something has overflowed and/or an object is touching the control panel.	Clean the hob or remove the object in question and start cooking again.
A series of little  (or F7) appears	Electronic circuits have overheated.	See " Fitting your hob ".
The hob does not work , another message comes on	The electronic circuit is working badly.	Call the After Sales Service
After having turned on a heating zone, the keyboard displays continue to flash.	The saucepan you use is unsuitable for induction cooking or its diameter is under 12 cm. (10 cm on the 160 mm zone).	See containers.
The pans make a noise during cooking	This comes from vibrations made by energy going from the hob to the pan.	Under high power this phenomenon is normal with certain types of pans. There is no danger for the hob.
The hob gives off a smell when first used for cooking	A new apparatus	Use each heating zone for ½ hour with a pan full of water.

If the slightest break or crack appears in the ceramic glass surface, disconnect the unit immediately and contact your After Sales Service.

DISHES	FRYING BRINGING TO THE BOIL		COOKING/BROWNING BRINGING BACK TO THE BOIL STEADY SIMMERING				COOKING KEEPING SIMMERING WARM		
	9	8	7	6	5	4	3	2	1
SOUPS									
FISH									
SAUCES									
VEGETABLES									
MEAT									
DEEP FRYING									
MISCELLANEOUS									

maximum power is reserved for frying and quick boiling.

- slow cooking
- fast cooking
- boil or fry
- boil with cover
- add food