

10 Sunnen Drive
St. Louis, MO 63143
telephone: 314-678-6336
fax: 314-781-2714
www.bloomfieldworldwide.com

**OWNERS MANUAL
for
SINGLE
SATELLITE
COFFEE BREWER
with
E-MAX
CONTROL
and
EXTERNALLY HEATED
SATELLITE SERVERS**

**MODEL:
2121**

Includes:

**Installation
Operation
Use & Care
Servicing Instructions**

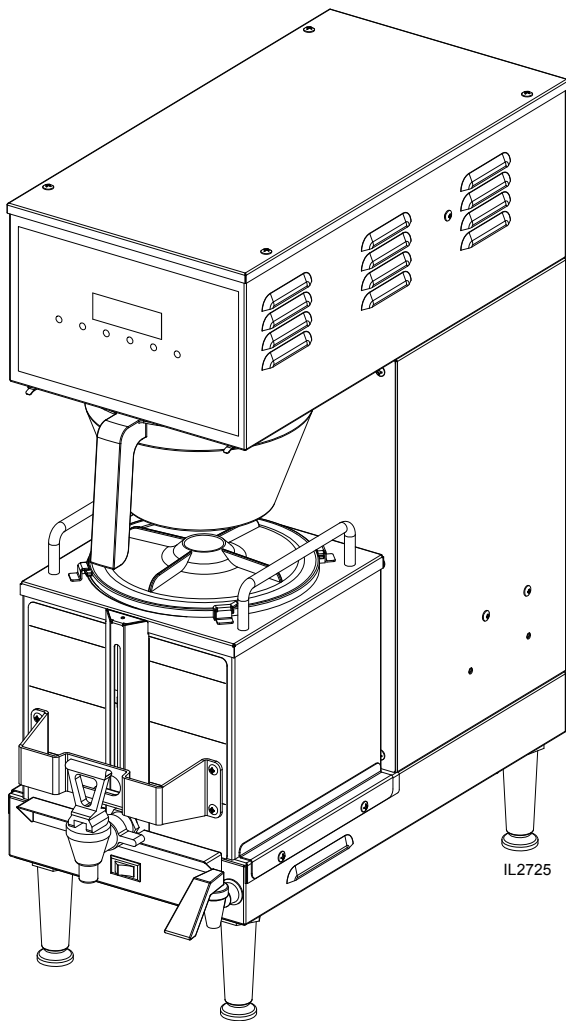

Model 2121 Single Satellite Brewer

WARRANTY STATEMENT

All equipment manufactured by Bloomfield is warranted against defects in materials and workmanship for the time periods listed in the chart starting from the date the equipment is placed into service and is for the benefit of the original purchaser:

THE FOREGOING OBLIGATION IS EXPRESSLY GIVEN IN LIEU OF ANY OTHER WARRANTIES, EXPRESSED OR IMPLIED, INCLUDING ANY IMPLIED WARRANTY OF MERCHANTABILITY OR FITNESS FOR A PARTICULAR PURPOSE, WHICH ARE HEREBY EXCLUDED.

BLOOMFIELD, LLC SHALL NOT BE LIABLE FOR INDIRECT, INCIDENTAL OR CONSEQUENTIAL DAMAGES OR LOSSES FROM ANY CAUSE WHATSOEVER.

This warranty is void if it is determined that upon inspection by an authorized service agency that the equipment has been modified, misused, misapplied, improperly installed, or damaged in transit or by fire, flood or act of God.

It also does not apply if the serial nameplate has been removed or unauthorized service personnel perform service. The prices charged by Bloomfield for its products are based upon the limitations in this warranty. Seller's obligation under this warranty is limited to the repair of defects without charge by a Bloomfield Authorized Service Agency or one of its sub-agencies. This service will be provided on customer's premises for non-portable models. Portable models (a device with a cord and plug or a dispenser) must be taken or shipped to the closest authorized service agency, transportation charges prepaid, for services.

Agencies are located in principal cities, please visit our website to locate one.

This warranty is valid in the United States and Canada and void elsewhere. Please consult your classified telephone directory or your food service equipment dealer; or, for information and other details concerning warranty, write to:

Service Parts Department; Bloomfield
10 Sunnen Drive, St. Louis, MO 63143

Phone: (314) 678-6336 : Fax: (314) 781-2714

Technical@bloomfieldworldwide.com / www.bloomfieldworldwide.com

Equipment	Parts	Labor
pour over, automatic coffee brewers	2 yrs.	2 yrs.
EBC, EMAX coffee brewers	2 yrs.*	2 yrs.
* EBC, EMAX coffee brewer control	3 yrs.	no labor
POD coffee brewers	1 yr.	1 yr.
ECO coffee brewers	1 yr.	1 yr.
coffee warmers	1 yr.	1 yr.
tea brewers	2 yrs.	2 yrs.
tea dispensers	1 yr.	1 yr.
tea dispenser BBTea	1 yr.	no labor
hot water machines	2 yrs.	2 yrs.
thermal servers	90 days	no labor
airpots	30 days	no labor
decanters	no warranty	no warranty

BLOOMFIELD SERVICE POLICY AND PROCEDURE GUIDE ADDITIONAL WARRANTY EXCLUSIONS

1. Resetting of safety thermostats, circuit breakers, overload protectors, or fuse replacements.
2. All problems due to operation at voltages other than specified on equipment nameplates - conversion to correct voltage must be the customer's responsibility.
3. All problems due to electrical connections not made in accordance with electrical code requirements and wiring diagrams supplied with the equipment.
4. Replacement of items subject to normal wear, to include such items as knobs and light bulbs. Normal maintenance functions including adjustment of thermostats, microswitches, and replacement of fuses and indicating lights are not covered under warranty.
5. All problems due to inadequate water supply, such as fluctuating, or high or low water pressure.
6. All problems due to mineral/calcium deposits, or contamination from chlorides/chlorines. De-liming is considered a preventative maintenance function and is not covered by warranty.
7. Full use, care and manuals may or may not be sent with each unit, only a condensed version. Please visit our web site to download the full version.
8. Travel mileage is limited to fifty (50) miles from an authorized service agency or one of its sub-service agencies.
9. All labor shall be performed during normal working hours. Overtime premium shall be charged to the customer.
10. All genuine Bloomfield replacement parts are warranted for ninety (90) days from date of purchase on non-warranted equipment. **Any use of non-genuine Bloomfield parts completely voids any warranty.**
11. Installation, labor and job checkouts are not considered warranty.
12. Charges incurred by delays, waiting time or operating restrictions that hinder the service technicians ability to perform services are not covered by warranty. This includes institutional and correctional facilities.

SHIPPING DAMAGE CLAIMS PROCEDURE

NOTE: For your protection, please note that equipment in this shipment was carefully inspected and packaged by skilled personnel before leaving the factory. Upon acceptance of this shipment, the transportation company assumes full responsibility for its safe delivery.

IF SHIPMENT ARRIVES DAMAGED:

1. **VISIBLE LOSS OR DAMAGE:** Be certain that any visible loss or damage is noted on the freight bill or express receipt, and that the note of loss or damage is signed by the delivery person.
2. **FILE CLAIM FOR DAMAGE IMMEDIATELY:** Regardless of the extent of the damage.
3. **CONCEALED LOSS OR DAMAGE:** if damage is unnoticed until the merchandise is unpacked, notify the transportation company or carrier immediately, and file "CONCEALED DAMAGE" claim with them. This must be done within fifteen (15) days from the date the delivery was made to you. Be sure to retain the container for inspection.

Bloomfield cannot assume liability for damage or loss incurred in transit. We will, however, at your request, supply you with the necessary documents to support your claim.

TABLE OF CONTENTS

WARRANTY STATEMENT	xi
SPECIFICATIONS	1
FEATURES & OPERATING CONTROLS	2
PRECAUTIONS & GENERAL INFORMATION	4
AGENCY APPROVAL INFORMATION	4
INSTALLATION	5
OPERATION	7
CLEANING INSTRUCTIONS	10
SERVICING INSTRUCTIONS	12
<i>Delime the water tank</i>	12
<i>Draining hot water tank</i>	13
<i>Timer Adjustment</i>	14
<i>Temperature Adjustment</i>	15
TROUBLESHOOTING SUGGESTIONS	16
EXPLODED VIEWS	17
WIRING DIAGRAM	26

Thank You for purchasing this Bloomfield appliance.

Proper installation, professional operation and consistent maintenance of this appliance will ensure that it gives you the very best performance and a long, economical service life.

This manual contains the information needed to properly install this appliance, and to use, care for and maintain or repair the appliance in a manner which will ensure its optimum performance.

SPECIFICATIONS

MODEL	VOLTS 60 Hz 1ø	Hz	WATS	AMPS	POWER CORD
2121	120/240V3/WN	50/60Hz1ø	3150	26.25/13.125	Requires 3-wire (L1, L2, N plus Gnd) cord - not provided

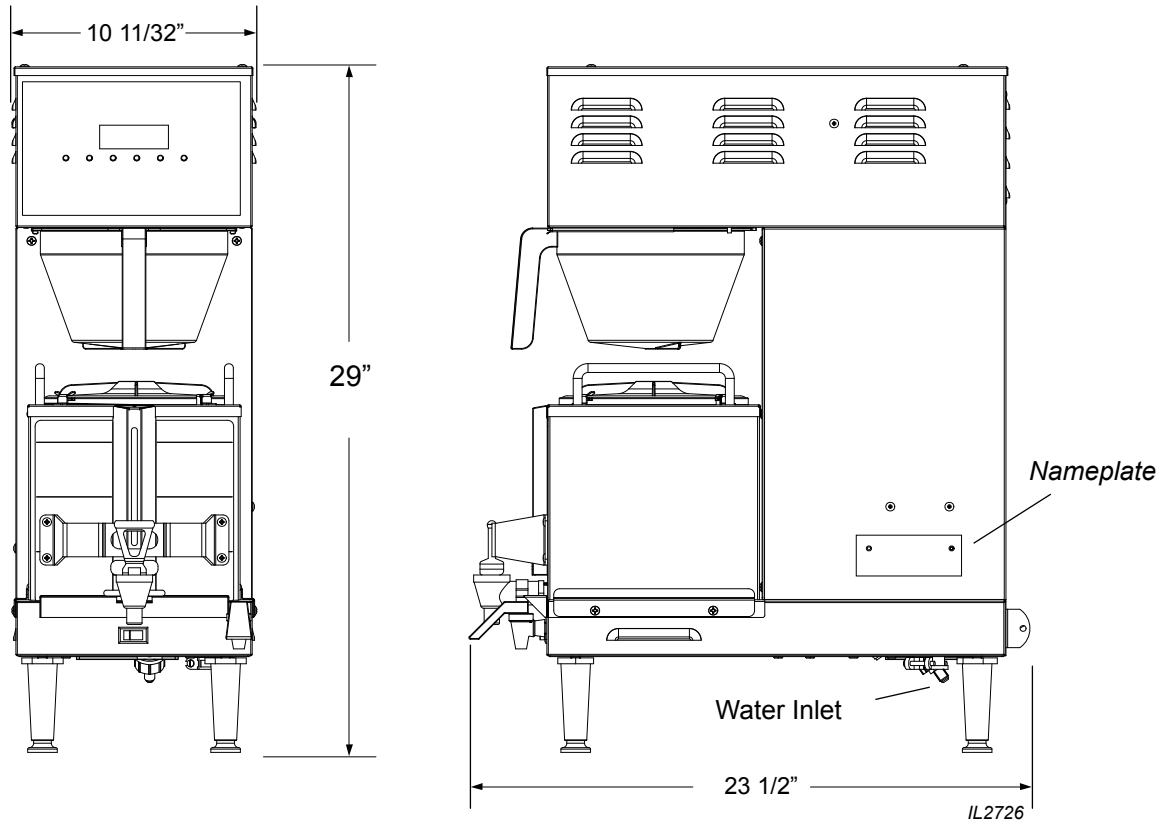

FEATURES AND OPERATING CONTROLS

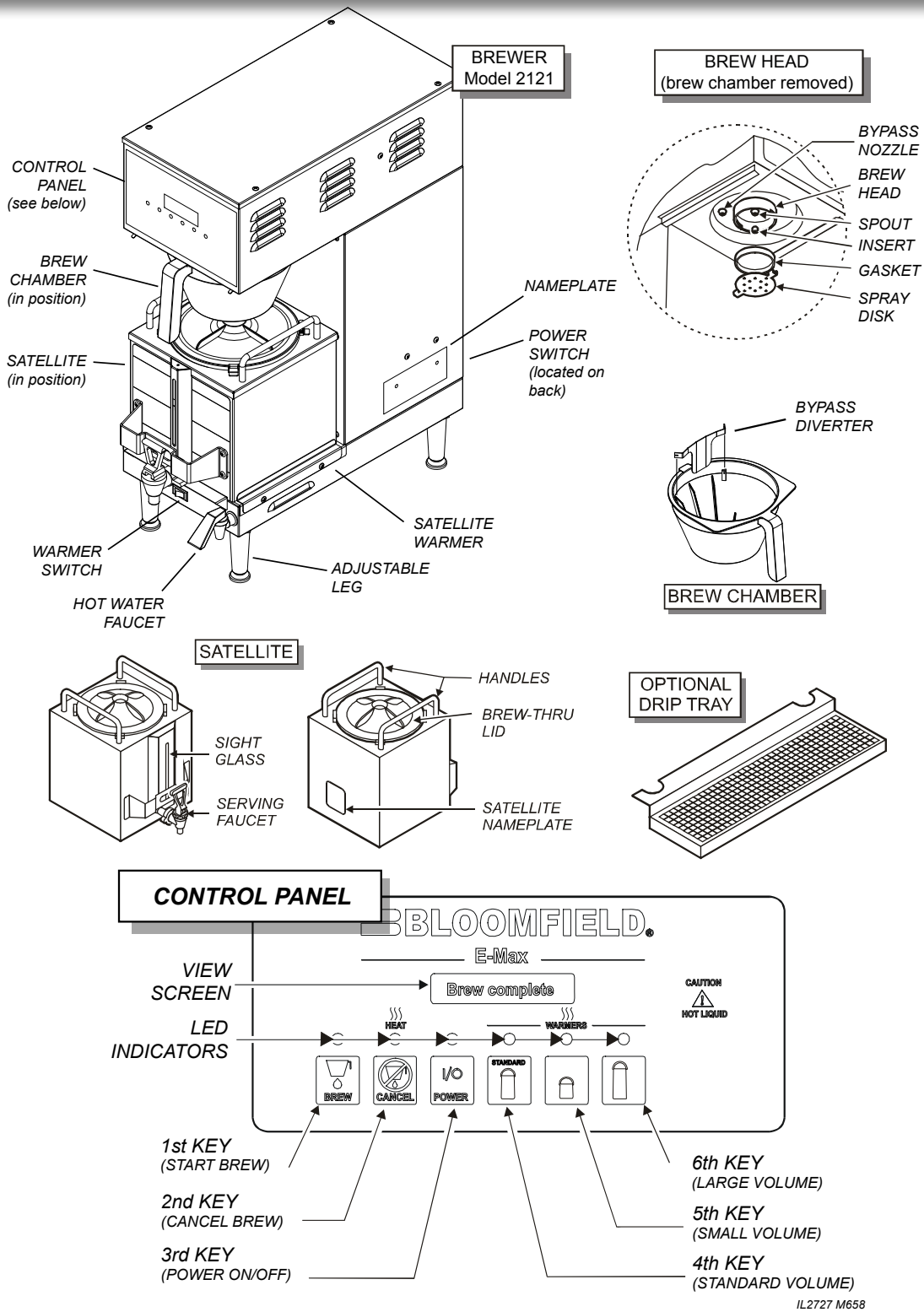

Fig 1. 2121 Satellite Brewing System Features & Operating Controls

658 2M-217969 Owners Manual 2121 E-Max Satellite Brewer

IL2727 M658

FEATURES AND OPERATING CONTROLS (continued)

Brewer

Adjustable Legs	Allows brewer to be leveled. Also allow clearance for cleaning underneath brewer.
Brewing Controls	Start or stop brew and select brew volume.
Bypass Valve	Dilution water flows into brew chamber channel from here. Dilution water DOES NOT flow through the coffee grounds.
Hot Water Faucet	Hot water dispensed here.
Nameplate	Lists manufacturer, model and serial number. Also lists voltage and wattage rating of brewer.
System Switch (not shown)	Located on lower right rear of brewer. Turns main power to brewer <i>ON</i> or <i>OFF</i> .
Satellite Locator/Warmer	Positions externally heated satellite on brewer. Maintains temperature of product in satellite.
Warmer Switch	Control individual warmer for externally heated satellite .

Brew Chamber

Brew Chamber	Holds coffee grounds during brew cycle.
Bypass Diverter	Forms dilution flow channel by holding filter clear of the brew chamber wall.

Satellite

Brew-Thru Lid	Allows entry of brewed coffee and dilution water into satellite. Minimizes splashing in the event satellite is tipped.
Handles	Allow the satellite to be safely carried.
Nameplate	Lists manufacturer, model and serial number. Also lists voltage and wattage rating of satellite.
Serving Faucet	Fresh coffee dispensed from satellite here.
Sight Glass	Check the level of coffee remaining here.

Drip Tray (optional)

Optional drip tray catches drips and spills from serving faucet. Easily removed for cleaning.

GENERAL INFORMATION AND PRECAUTIONS



WARNING: SHOCK HAZARD

All servicing requiring access to non-insulated electrical components must be performed by a factory authorized technician. DO NOT open any access panel that requires the use of tools. Failure to follow this warning can result in severe electrical shock.



CAUTION: BURN HAZARD

Surfaces of this brewer can be hot and can cause burns on contact.

This appliance is intended for use in commercial establishments only.

This appliance is intended to brew hot beverage, specifically coffee, for human consumption. No other use is recommended or authorized by the manufacturer or its agents.

Operators of this appliance must be familiar with the appliance use, limitations and associated restrictions. Operating instructions must be read and understood by all persons using or installing this appliance.

Cleanliness of this appliance is essential to good sanitation. Read and follow all included cleaning instructions and schedules to ensure the safety of the food product.

Surfaces of the brewer, brew basket and satellite can be hot to the touch, and may cause burns on contact.

Disconnect the brewer from electrical power before performing any maintenance or servicing.

DO NOT submerge satellites in water.

DO NOT splash or pour water over, onto or into any controls, control panel or wiring.



Any procedure which requires the use of tools must be performed by a qualified technician.

This manual is considered to be a permanent part of the appliance. This manual and all supplied instructions, diagrams, schematics, parts breakdown illustrations, notices and labels must remain with the appliance if it is sold or moved to another location.

This appliance is made in the USA. Unless otherwise noted, this appliance has American sizes on all hardware.

AGENCY APPROVAL INFORMATION



This single satellite brewing system is  listed under E9253 and  listed under E9253.



This single satellite brewing system meets NSF Standard 4 only when installed and maintained per the instructions in this manual.



INSTALLATION INSTRUCTIONS

INSTALL LEGS

The brewer is provided with 4" adjustable legs and rubber feet. Be sure the legs are securely screwed into the base of the brewer, and that the rubber feet are properly installed.

LEVEL THE UNIT

The adjustable legs allow the brewer to be leveled. Set the brewer in its ultimate operating location and check for level with a spirit level. Adjust the brewer for level from front-to-rear, and from side-to-side. Be sure all four feet rest firmly on the counter.

PLUMBER'S INSTALLATION INSTRUCTIONS

IMPORTANT:

This equipment must be installed in accordance with the Basic Plumbing Code of the Building Officials and Code Administrators International (BOCA), and the Food Service Sanitation Manual of the Food and Drug Administration (FDA). Also, this equipment installation must comply with all local plumbing codes and ordinances.

IMPORTANT:

Brewer must be installed on a water line with a full-flow pressure between 20 psi and 90 psi.

NOTE: If water pressure varies greatly, or exceeds 90 psi at any time, a water pressure regulator must be installed. Plumbing installer must supply the regulator.

Brewer must be connected to a potable water supply. Bloomfield recommends not less than 1/4" copper tubing for installations of 12' or less, and not less than 3/8" copper tubing for installations exceeding 12'. Brewer must be connected to a COLD water line.

NOTE: DO NOT use a saddle tap for this water line connection.

A shut-off valve must be installed between the main water supply and the brewer. Plumbing installer must supply the shut-off valve. A 1/4-turn ball valve is recommended.

Bloomfield highly recommends the use of the provided water strainer to help prevent deposits in the brewing system.

Flush the water line before connecting to the brewer.

ELECTRICIAN'S INSTALLATION INSTRUCTIONS

Brewer requires a dedicated single-phase circuit:

Model 2121 120/208-240 Volt AC, 60 Hz 30 Amp circuit
3-Wire (L1, L2, N plus Gnd)

NOTE:

To enable the installer to make a quality installation and to minimize installation time, these tests and suggestions should be completed before the actual installation is begun.



CAUTION: UNSTABLE EQUIPMENT HAZARD

Rubber feet must be installed on each leg of the brewer. Legs must be adjusted so that all four feet rest firmly on the counter. Failure to properly install the feet can result in movement of the brewer, which can cause personal injury and/or damage to the brewer.

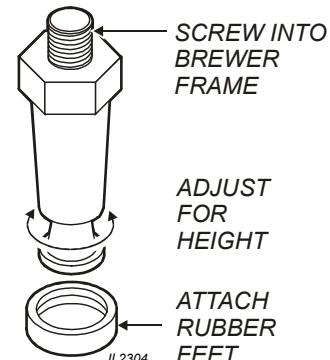

Fig. 2 Adjustable Legs



CAUTION: SHOCK HAZARD

Brewer must be properly grounded to a reliable earth ground to prevent possible shock hazard. Do not assume a plumbing line will provide such a ground. Electrical shock may cause serious injury.

OPERATION

OPERATING INSTRUCTIONS

IMPORTANT:

All E-Max brewers are tested and set at the factory. If programming adjustments are necessary, refer to the E-Max Programming Manual (p/n 2M-73674).

To over-ride the Brew Wait mode, press and hold the BREW key for 3 seconds when the brewer is in Brew Wait mode (i.e. when brew light is flashing). The brew will proceed immediately regardless of water temperature. This feature should only be used when testing water volume, otherwise the brew will proceed with the water below the precise brew temperature.

Note: the following safety features have been incorporated to prevent multiple unattended brews:

The brew key is disabled during a brew cycle. This minimizes the possibility of double brewing.

When the "Brew" light is on or flashing, repeated pressing of the BREW switch will be ignored, (there will be a beep each time it is pressed). A Brew will only be activated when the "Brew" light is off.

- 1. Energizing the Brewer:** When electricity has been connected to the unit, there will be a momentary flash of the power light.

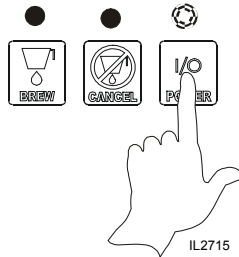

Turn the brewer on by pressing the POWER key. The brewer will start to fill the tank. With the proper water supply the tank should be filled in about 2½ minutes. Once filled, the heating element will come on until the proper tank temperature has been reached, (which will take about 20 minutes on 120-Volt models or about 12 minutes on 120/240 Volt models).

- 2. Brewing (Precise Temperature for Brewing — PTB):** In the regular operating mode, the E-Max maintains the tank temperature within +/- 1°F of the brew temperature. Normally this will mean that a brew will be started as soon as the BREW key is pressed. However, there may be a slight delay if the BREW key is pressed immediately after a brew has been completed (notably on 120 volt models). If the tank temperature is below the brew temperature, the brew will be delayed, going into the "Brew Wait" mode, with the brew light flashing. As soon as the correct temperature is reached the brew will commence with the brew light on continuously during the brew. When the brew begins the main warming station will be turned on automatically (if it is not already on). During the brew cycle, if the BREW key is pressed, it will be ignored. Only when the brew is complete can another brew be started.

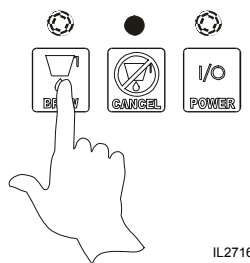

- 3. Brew Cancel:** To cancel a brew in progress, press the CANCEL KEY: two beeps will sound and the "Brew" light will go out. Water flowing to the brew chamber will be stopped immediately, but if there is already water in the brew chamber, it will take a few moments before this drips through as tea.



- 4. Normal Operation (Non Brewing):** When the unit is not brewing, the E-Max maintains the water temperature at the Precise Temperature for Brewing (PTB). The heating element will cycle on and off automatically to maintain this temperature.
- 5. After Hours Mode:** If no brew is detected for a pre-selected length of time, the brewer will enter the After Hours mode. Temperature will be allowed to drop to save energy. Pressing the BREW KEY returns the brewer to normal operation.

USER'S GUIDE

1. Remove the **brew chamber** from under the spray head. Place one (1) genuine Bloomfield paper filter into the brew chamber. Add your choice of pre-measured tea leaves. Shake the brew chamber gently to level the tea leaves. Slide the brew chamber back into place.

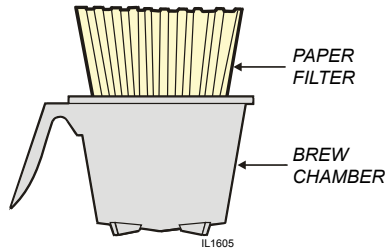

WARNING: Burn Hazard

This appliance dispenses very hot liquid. Serious bodily injury from scalding can occur from contact with dispensed liquids.

2. Place an empty **dispenser** under the brew chamber.

3. If any volume other than "Standard" brew volume is required, press the appropriate volume key.

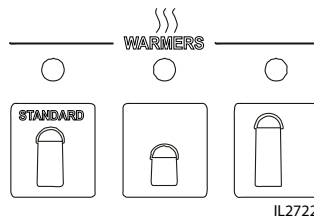

CAUTION: Burn Hazard

To avoid splashing or overflowing hot liquids, ALWAYS use an empty dispenser before starting the brew cycle. Failure to comply can cause serious burns.

4. To begin the brew cycle, press BREW key. Hot water will start spraying over the coffee grounds, and brewed coffee will start filling the server. Cold water will flow from the bypass valve to bring the coffee to the proper concentration. When the coffee stops flowing from the brew chamber, the fresh coffee is ready to serve.

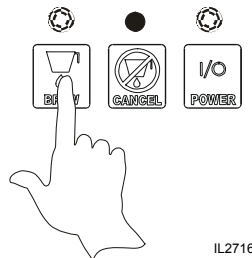

CAUTION: Burn Hazard

After a brew cycle, brew chamber contents are HOT. Remove the brew chamber and dispose of used filter and coffee grounds with care. Failure to comply can cause serious burns.

NOTE: Brewing will not begin until the Precise Temperature for Brewing has been reached. (See page 6)

5. At the end of the brew cycle, the view screen will read "Brew complete". After all dripping has stopped, remove the brew chamber from the brewer. Discard the used paper filter and coffee grounds.

Brew complete



CAUTION: Burn Hazard

Exposed surfaces of the appliance, as well as brew chamber may be HOT to the touch, and can cause serious burns.

6. The brewer is now ready to begin another brewing cycle.

OPERATION (continued)

PROGRAMMING FEATURES AND OPTIONS

- 1. View Water Temperature in Tank:** To view the water temperature on the screen, E-Max brewer must be ON, and not brewing or in the filling mode. Press and hold the 4th key, and depress the 6th key. The actual water temperature will be displayed for 3 seconds.
- 2. Daily Brew Count:** The E-Max maintains a count of the number of completed brews for a 7-day period. To access the count, turn the brewer OFF. In the OFF mode, press and hold the CANCEL key for 3 seconds. The current day and brew count will be displayed. Depress the ON/OFF key repeatedly to view each preceding day. When all 7 days have been displayed a 7-day total will be displayed. If you wish to exit the daily brew count before viewing all of the days, press CANCEL key.
- 3. ON/OFF – Non Automatic Timer:** To turn the brewer OFF, press the ON/OFF switch: 2 beeps will be heard and the brewer will be turned OFF, indicated by all lights being off. To turn the brewer ON, press the ON/OFF switch: 2 beeps will sound, all lights will flash once, then the “Power” light will remain on, (the “Heat” light may come on if water temperature is too low).
- 4. ON/OFF – Automatic Timer Feature:** The factory programmed E-Max has the automatic timer turned off. To set the automatic timer, refer to the E-Max Programming Manual, “Time Functions” Menu. If the Automatic Timer feature is programmed off, the brewer can be turned on and off by depressing the ON/OFF switch, as noted above.
 - * When the Automatic Timer feature is programmed ON, the E-Max will turn on and off automatically, at a programmed time, Monday to Friday; with a separate on and off programmed time schedule for Saturday and Sunday.
 - * Temporarily Overriding the Automatic ON/OFF function. While in the automatic timed OFF mode the brewer can be started by depressing the ON/OFF switch. The brewer will remain ON until the automatic programmed off time, when it will turn OFF and resume normal automatic timed functioning. Similarly, if turned OFF during the automatic timed ON mode the brewer will remain OFF until the next programmed on time, when it will turn on and resume normal automatic timed functioning.
- 5. Automatic Start-Up in Previous Mode:** If the E-Max automatic timer is OFF (the factory setting) and power is disconnected, the brewer will start up when power is restored, in the mode it had been in prior to the power disconnection. If the E-Max has the timer setting ON and power is disconnected, the brewer will start up in the mode that it should be in at the time the power is restored.
- 6. Viewing Programmed Brew Volume:** The E-Max can have up to 4 different brew volumes. When a volume other than the standard, or first brew volume, is selected, the E-Max will complete that volume and then automatically reset to the standard, or first brew volume. With the brewer ON, press and hold the CANCEL key. The 1st, or standard, volume will be displayed for 3 seconds (i.e. Volume #1 3 G), and then the day and time will be displayed.
- 7. Changing Brew Volume:** Press the required volume key. If a volume is programmed for that key, the volume will be displayed on the screen for 3 seconds and the light above the key will be turned on. If no volume is programmed, the previous light will remain on and the screen will read “no volume prog” (i.e. no volume programmed). When a brew volume other than the 1st, or standard brew volume is selected, the E-Max will complete the brew then return to the 1st or standard brew volume automatically.

8. Clock

- A. Time – Battery Backup.** The E-Max has a battery backup system which will maintain the proper time during power failures, or when the brewer is unplugged (even for very prolonged periods of time). Normally there will not be a need to set the time except for Daylight Saving Time changes, or moving the brewer to different time zones.
- B. Changing Day and Time:** To change time, turn the E-Max off. Press the 2nd key twice followed by the 1st key twice to access the time change mode, (i.e. press CANCEL, CANCEL, BREW, BREW). In the time change mode the screen will read “Day:” followed by the current day setting. Use the 6th key to advance the day, or the 5th key to reverse. When day has been properly set, press the 3rd key. The screen will now read “Time:” with the set time on the screen, the hour and am or pm flashing. Use the 5th key to go back or the 6th key to advance the hour, making sure that the am or pm is correct. When the hour and am/pm is correctly set, press the 3rd key, and the screen will read “Time:” with the set time on the screen, minutes flashing. As previously use the 5th or 6th keys to adjust the minutes, and press the 3rd key when complete. E-Max will return to the off mode. (Changing time can also be done in the regular programming mode. Consult the E-Max *Programming Manual*)
- C. After Hours:** Consult the E-Max *Programming Manual* to set the After Hours mode. The factory programming has the After Hours mode turned OFF. The After Hours can be programmed to come on from 1 to 6 hours after the last brew. When the E-Max goes into the After Hours mode, any warmer plates left on will be turned off (on decanter brewers), the water in the tank will be allowed to drop from the normal brewing temperature and will reheat less frequently – this feature saves energy and extend component life. While in the After Hours mode, the power light will flash continuously. When the BREW switch is pressed the E-Max automatically reverts back to normal operation, heating the water to the Precise Temperature for Brewing (PTB), before starting the brew. (The power light will be on continuously and the Brew light will flash until the correct water temperature is reached.)
- 9. Countdown Quality Timer:** Refers to coffee warmers, when “ON” the warmers will automatically turn off between 20 to 120 minutes, depending on how they are programmed.

OPERATION (continued)

10. Pulse or Pre-Infusion Volume Options: these three (3) volumes have been preset at the factory as the following sample programs. *To change these settings refer to E-Max Programming Manual 2M-73674.* refer to E-Max Programming Manual, Brew Settings Menu. If a particular brew volume has utilized the pulse or pre-infusion option, that volume will be displayed with an asterisk (*) after the volume.

As an example “**Volume#2 3 G***” would indicate that the second programmed brew volume has utilized the pulse or pre-infusion program options.

DEFAULT PROGRAMS			
Type: Satellite	Key Positions 4, 5 & 6		
	1 Gallon	1/2 Gallon	1-1/2Gallon
Total Valve	215	142	322
Press 4th Key			
Init. Valve Time	30		
Pulse Delay	5		
Pulse Valve On	10		25
Bypass Time	150	50	200
Brew Complete	45	30	60

Approximate Flow Rates
To determine brew time for a volume divide ounces by flow rate:
Brew Valve; .50oz sec
Bypass; .27oz sec

11. Keypadlock: This feature is OFF in the standard factory settings. To set the feature refer to E-Max Programming Manual, Machine Settings Menu. If the Keypadlock feature is activated, there will be no response by the brewer when the keys are depressed (except for the beep after a key is depressed). To temporarily “unlock” the keypad, press and hold the CANCEL key for 6 seconds. A beep will be heard indicating the keypad is now “unlocked”, — a brew can be initiated, warmer plates turned on or off, etc. The keypad will remain unlocked until the brew is completed, then automatically return to keypadlock mode. If a brew is not initiated 60 seconds after “unlocking”, the system will time out and return to the “locked” position.

12. View Filter Statistics: To view filter statistics, turn the brewer off. Press and hold the 1st key (Brew), and depress the 3rd (ON/OFF) key. Total water volume will be displayed (TotalVol.). Press the 3rd key to view the Filter Life (FltrLife:). Press the 3rd key to view the percentage of the filter that has been used. (If the filter option is used, the filter life volume needs to be entered in the program – see E-Max Programming Manual, Service & Counters Menu.)

13. Diagnostic Messages – Programmed Safety Features: When E-Max senses a problem, it will automatically turn off all elements and valves, flash lights, display the message “Call For Service” and display one of the messages below. (Additionally: a service phone number may appear if it has been programmed into the system.)

*To reset the brewer it can be re-energized (or press and hold CANCEL for 3 seconds for all faults except the Valve Fault, which must be reset by re-energizing). The brewer will try to re-start, but if the same problem persists, the appropriate error message will appear again. Consult the Trouble Shooting section to determine how to solve the problem.

- A. **“Probe/Heater Error”:** Overheating Detection (1): If the heating element is on for 5 minutes and the temperature does not change by +2°F (1°C) in the five minute period, the unit will go into the Over Temperature Mode with all lights flashing. When in this mode the brewer turns off the heating elements, the solenoid valves are turned off; the switches disabled; (and all lights flashing continuously). The LCD display will read **“Probe/Heater Error”**, followed by the message **“Call for Service”**, and then the service phone number (if it has been entered into memory). To reset press and hold CANCEL for 3 seconds, or re-energize the brewer. (Possible causes of problem: high limit needs to be re-set; defective high limit, element, triac, water level probe or control board.)
- B. **“Overheat Error”:** Overheating Detection (2): If the E-Max senses a temperature over the Maximum Temperature set in the program (factory set at 208°F or 98°C) it will go into the over temperature mode as above with all lights flashing, except the LCD will read **“overheat error”**, and **“Call for Service”**. To reset press and hold CANCEL for 3 seconds, or re-energize the brewer. (Possible cause of problem is a defective triac, temperature probe or related wiring and connections.)
- C. **“No Water Sensed” — Time-Out —Inlet Valve:** When filling for the first time, the inlet valve will remain open for 4¼ minutes, (the screen will read **“filling...”**). If water is not detected at the end of this time the E-Max will shut down with the message **“no water sensed”**. The valves and all elements are turned off, and the Brew and Power light flash alternately with the Heat light, until the brewer is reset. To reset press and hold CANCEL for 3 seconds, or re-energize the brewer. (Possible causes of the problem are: no incoming water; slow flow of incoming water (i.e. less than 45 oz/minute); sensor not reading (check for placement, connections or lime scale).

INSTALLATION INSTRUCTIONS (continued)

IMPORTANT:

Initial set-up must be performed by a qualified installer or qualified service technician. Improper set-up will damage the brewer and void the warranty.

IMPORTANT:

Complete water line installation before connecting brewer to electrical power.

INITIAL SET-UP INSTRUCTIONS

Plumber's and Electrician's installation procedures must be completed before proceeding with the set-up.

Be sure all electrical connections are secure, and that all plumbing connections are secure and leak-proof.

1. CHECK BREWER FOR PROPER CONFIGURATION

Make sure spray disk gaskets are in place **INSIDE** of spray heads.

Make sure spray disks are properly installed.

Check hot water faucet for proper operation and leaks.

Place empty satellites in position.

2. START BREWER OPERATION

When electricity has been connected to the unit, there will be a momentary flash of the power light. Turn the brewer on by pressing the **POWER** key.

The brewer will start to fill the tank. With the proper water supply the tank should be filled in about 2½ minutes. Once filled, the heating element will come on until the proper tank temperature has been reached, (which will take about 20 minutes on 120-Volt models or about 12 minutes on 120/240 Volt models).

3. FINAL CHECKS

After initial heat-up and before brewing, draw water from the hot water faucet until the inlet solenoid actuates. This will prevent volume differences to the initial brew caused by water expansion.

Press **SATELLITE WARMER** switch on. Brewer will not operate unless the appropriate **SATELLITE WARMER** switch on.

OPERATING INSTRUCTIONS (continued)

WATER FLOW

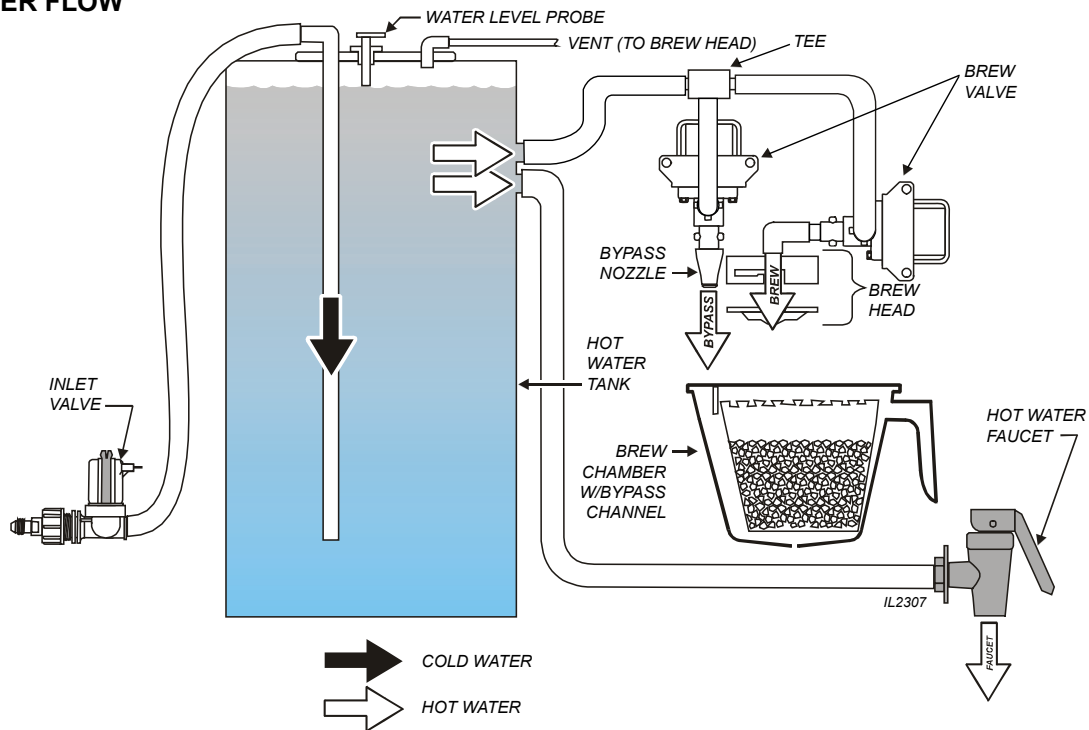

INLET

The INLET VALVE is controlled by a signal from the CONTROL BOARD. If the WATER LEVEL PROBE does not detect water, the inlet solenoid is opened until water is again sensed.

BREW AND BYPASS

The BREW VALVE is fed by gravity from the hot water tank. The brew valve is opened for a length of time as determined by the CONTROL setting. The brew valve discharges through the BREW HEAD:

- A portion of water is fed to the BYPASS through a reducing “tee”. The amount of bypass water is controlled by CONTROL BOARD settings. Bypass water flows through the brew basket, but is diverted from the grounds by a bypass channel.
- The remainder of the brew water is discharged through the BREW HEAD and flows over the grounds in the brew basket.

HOT WATER FAUCET

The HOT WATER FAUCET is fed by gravity from the hot water tank. The faucet is spring-loaded closed and manually opened.

The hot water faucet is fed by the hot water tank, but is otherwise independent of the brewing systems.

NOTE:

Use of the hot water faucet during a brew cycle will not change the delivered volume. However, excessive use of the faucet during brew may lower the brew water temperature.

CLEANING INSTRUCTIONS



CAUTION: BURN HAZARD

Brewing and serving temperatures of coffee are extremely hot. Hot coffee will cause serious skin burns.

PROCEDURE: Clean Coffee Brewer

PRECAUTIONS: Press POWER key to OFF.
Allow brewer to cool.

FREQUENCY: Daily

TOOLS: Mild Detergent, Clean Soft Cloth or Sponge
Bristle Brush

IMPORTANT:

DO NOT use steel wool, sharp objects, or caustic, abrasive or chlorinated cleansers to clean the brewer, brew baskets or satellites.

DO NOT immerse or submerge satellites in water.

1. Press POWER key to OFF.
Allow brewer to cool.
 2. Remove satellites.
 3. Remove and empty brew baskets.
 4. Remove spray disks and gaskets from spray heads
 5. Wipe inside of spray head and area around spray head with a soft clean cloth or sponge moistened with clean water.
 6. Wash spray disks in a sink using warm water and a mild detergent. A bristle brush may be used to clear clogged spray holes. Rinse spray disks with clean water and allow to air dry.
 7. Wash brew baskets in a sink using warm water and a mild detergent. A bristle brush may be used to clean around the bypass diverters. Rinse with clean water and allow to air dry. Be sure bypass diverters are properly installed.
 8. Remove and drain the drip tray. Rinse in a sink under warm running water. Allow to air dry, then reinstall on brewer.
 9. Wipe exterior of brewer and satellites with a soft clean cloth or sponge moistened with clean water.
 10. Reinstall gaskets INSIDE brew heads, and then reinstall spray disks.
 11. Reinstall brew chambers.
 12. Reinstall satellites.
- Procedure is complete

CLEANING INSTRUCTIONS (continued)

PROCEDURE: Clean Satellite

PRECAUTIONS: Drain Satellite before Cleaning

FREQUENCY: Twice Weekly

TOOLS: Sight Glass Brush, Sanitizer
Soft Clean Cloth, Bucket



CAUTION: BURN HAZARD

Brewing and serving temperatures of coffee are extremely hot. Hot coffee will cause serious skin burns.

IMPORTANT:

DO NOT submerge satellite in water.

IMPORTANT:

DO NOT use steel wool, sharp objects, or caustic, abrasive or chlorinated cleansers to clean the satellites.

1. Remove and drain satellites. Remove lids.
2. Place 1 packet of Sanitizer into 2-1/2 gallons of warm tap water. Pour approximately 1 gallon of sanitizer solution into each satellite. Allow to stand for 2 minutes.
3. Drain sanitizer solution from satellite into the bucket.
4. Disassemble faucet. Brush clean with sanitizer solution. Reassemble faucet.
5. If necessary, disassemble and clean sight glass.
 - a. Push down on ears on sight glass guard. Then, pull ears forward. Lift guard off of retaining clip.
 - b. Remove sight glass tube from silicone elbow. Run the sight glass brush through the tube at least ten times.
 - c. Reassemble the tube to the silicone elbow. Be sure the elbow has not been pulled from the satellite body.
 - d. Reinstall the sight glass guard.
6. Reinstall lids. Install satellites on brewer.
7. Rinse satellites: With an empty brew chamber in place, press the BREW key and run 1 full cycle into each satellite.
8. Drain water from satellites.

Procedure is complete

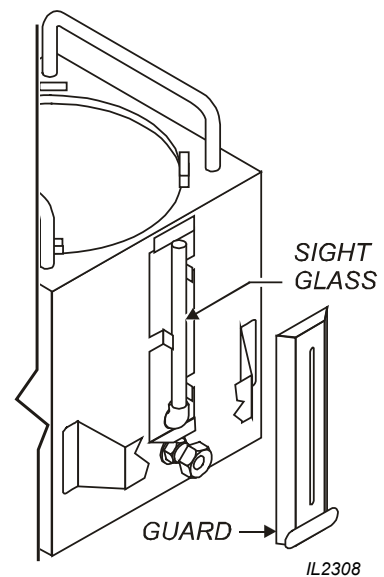

Sight Glass

SERVICING INSTRUCTIONS



CAUTION: CHEMICAL BURN HAZARD

Deliming chemicals may be caustic. Wear appropriate protective gloves and goggles during this procedure. Never siphon deliming chemicals or solutions by mouth.

This operation should only be performed by qualified and experienced service personnel.

PROCEDURE: Delime the Water Tank

PRECAUTIONS: Disconnect brewer from electric power.
Allow brewer to cool.

FREQUENCY: As required (Brewer slow to heat)

TOOLS: Deliming Solution
Protective Gloves, Goggles & Apron
Mild Detergent, Clean Soft Cloth or Sponge
Bristle Brush, Bottle Brush
Large Sink (or other appropriate work area)

IMPORTANT: DO NOT spill, splash or pour water or deliming solution into or over any internal component other than the inside of the water tank.

IMPORTANT: DO NOT allow any internal components to come into contact with the deliming solution. Take care to keep all internal components dry.

NOTE: Repeat steps 4 and 7 as required to remove all build-up.

1. Disconnect brewer from the electrical supply.
2. Remove the brewer top panel, then remove the tank lid assembly. Do not disconnect the tank assembly at this time.
3. Siphon all water from the hot water tank.
4. Mix 10 gallons of deliming solution according to the manufacturer's directions. Carefully pour the deliming solution into the water tank. Lower the lid assembly back onto the tank. Allow to sit for 30 minutes, or as directed by the chemical manufacturer.
5. At end of soaking period, reconnect brewer to electrical power. Install the brew chamber without filter paper or grounds. Place an empty satellite under the brew chamber. Force a 1-1/2 gallon brew:
 - a. Press the 1-1/2 gallon key
 - b. Press the brew key, then press and hold the brew key until a brew is initiated.Empty the satellite and repeat for the other side.
6. Disconnect brewer from electrical power and allow to cool.
7. Remove lid assembly from tank.
 - a. Using a stiff bristle brush, scrub internal components to remove lime and calcium build-up.
 - b. Thoroughly rinse internal components of lid assembly with clear water.
 - c. Store lid assembly in a safe location.
8. Using a stiff bristle brush, scrub exposed portions of the heating element and the inside surfaces of the tank to remove lime and calcium build-up.
9. Siphon all solution from the tank.

SERVICING INSTRUCTIONS (continued)

10. Reinstall tank lid assembly into hot water tank. Make sure the lid gasket is properly in place, then reinstall the hold-down clamps.
11. Remove spray disks and gaskets. Rinse both brew heads with clean water. Using a stiff brush, scrub spray disk to remove any lime or calcium build-up. Reinstall gaskets and spray disks.
13. Reconnect brewer to electrical supply .
14. Install the brew chamber without filter paper or grounds.
15. Place an empty satellite under the brew chamber. Run at least five 1-1/2 gallon brew cycles and discard all water generated at the end of each cycle. Repeat for the other side.
16. Rinse satellite with clean water. Reinstall one empty satellite under each brew chamber.

Brewer is ready to use.

NOTE: Normally, silicone hoses do not need to be delimed. Should deliming hoses become necessary, Bloomfield recommends replacing the hoses.

DRAINING HOT WATER TANK

1. Disconnect brewer from the electrical supply
 2. Remove the top panel assembly (4 Screws)
 3. Remove the front panel assembly (4 Screws)
 4. Release the drain hose & hose clamp assy from the retaining clip.
 5. Bring the drain hose down out the front panel so its lower than the tank.
 6. Remove the red hose cap.
 6. Open the hose clamp and drain into container.
- CAUTION:** Single Satellite tanks holds 3 gallons of water and can may contain HOT WATER,
7. When tank is empty, close the hose clamp and place the red cap back into position.
 8. Place the end of the hose back into its retaining clip

TROUBLESHOOTING SUGGESTIONS

DESCRIPTION OF PROBLEM	POSSIBLE CAUSE	SUGGESTED REMEDY
No lights or heat	Unit not plugged in or circuit breaker tripped	Restore electric power
No heat	Power switch OFF	Turn power switch ON
	Hi-limit safety tripped	Allow brewer to cool, verify water level, reset hi-limit
	Thermostat damaged	Replace thermostat
	Damaged hi-limit safety	Replace hi-limit
	Damaged heater switch	Replace heater switch
	Damaged heating element	Replace heating element
Brewer overflows	Water level probe corroded	Clean water level probe
	Poor ground connection	Verify ground connection
	Dirt in inlet valve or valve damaged	Replace inlet valve
	Brew valve damaged	Replace brew valve
	Tank water boiling	Adjust or replace thermostat
Brew chamber overflows	Too many paper filters or wrong filter used.	Use one genuine Bloomfield paper filter per brew
	Chamber discharge hole plugged	Clean brew chamber
	Timer not set properly	Set timer
	Too much coffee or too fine a grind	Check with coffee supplier for recommended grind and quantity
Heats slow	Connected to wrong voltage	Verify supply voltage
	Scale build-up on heating elements	De-lime hot water tank
	Damaged heating element	Replace element
Slow to fill	Insufficient water pressure	Brewer must be operated on a dedicated water line. Other equipment on line may be robbing water volume.
	Plugged water line strainer	Clean strainer
No heat to satellite	Warmer switch not on	Turn warmer switch on
	Damaged element or wiring	Replace as required
Poor coffee quality	Keep brewer and servers clean. Install a taste and odor filter in water supply, and replace cartridges regularly. Use a quality coffee with a consistent roast. Use proper grind and amount of coffee per brew.	

SATELLITE EXPLODED VIEW & PARTS LIST

SATELLITE MODEL 9440

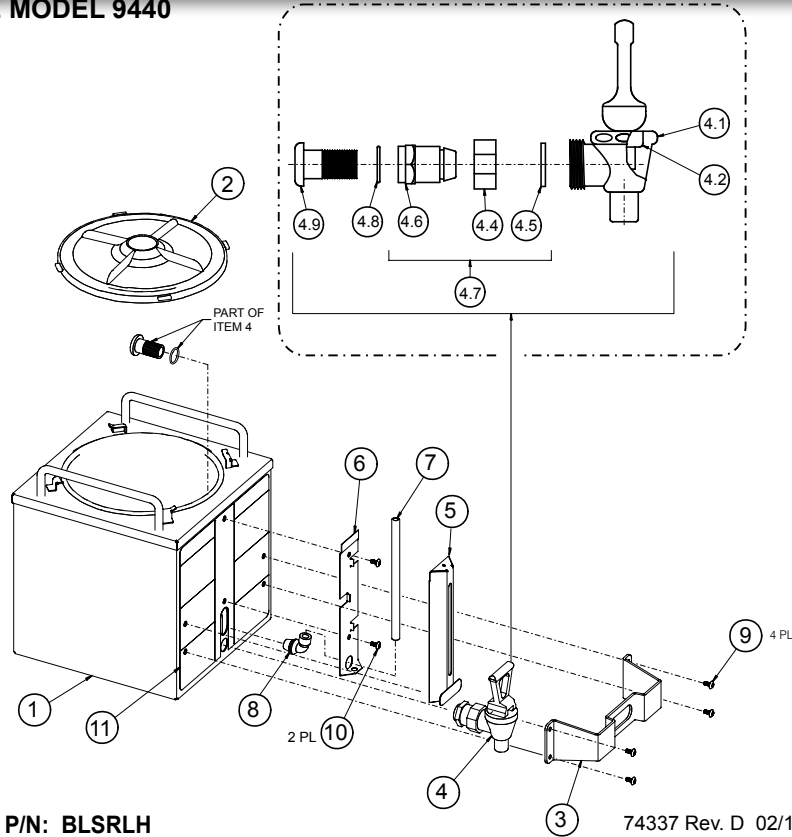

P/N: BLSRLH

74337 Rev. D 02/12/04
IL1855b

SATELLITE ASSEMBLY 9440

Fig No	Part No	Quantity	Description
1	D7-76657	1	WELDMNT SATELLITE ASSY
2	2L-73863	1	TANK LID ASSY, SRL-DP
3	2R-74313	1	HANDLE FAUCET GUARD
4	2U-76577	1	FAUCET & SHANK ASY
4.1	2V-Z15411	1	FAUCET ESP ULTEM HI TEMP
4.2	2U-71460	1	SEAT CUP TEA DISP FAUCET
4.4	2C-84393	1	HEX NUT-SPOUT VALVE
4.5	2C-H2016	1	WASHER-C-TOMLINSON
4.6	2A-84395	1	SHANK-FAUCET
4.7	2U-84396	1	SHANK ASSY FAUCET
4.8	2C-84489	1	WASHER-FIBER
4.9	2A-84488	1	FERRULE-VALVE SHANK
5	D7-74539	1	ASSY SIGHT GAUGE HOUSING
6	D7-74300	1	BRKT SIGHT GAUGE
7	D7-74354	1	TUBE SIGHT GAUGE
8	2K-70130	1	ELBOW SPRAYER
9	2C-76008	4	SCREW 8X1/2 PAN PH DRILL
10	2C-76007	2	SCREW 8AX1/2 SS TR PH SMS
11	2M-74342	1	DECAL SRL-H SATELLITE FRO

EXPLODED VIEW 2121 MAIN ASSEMBLY

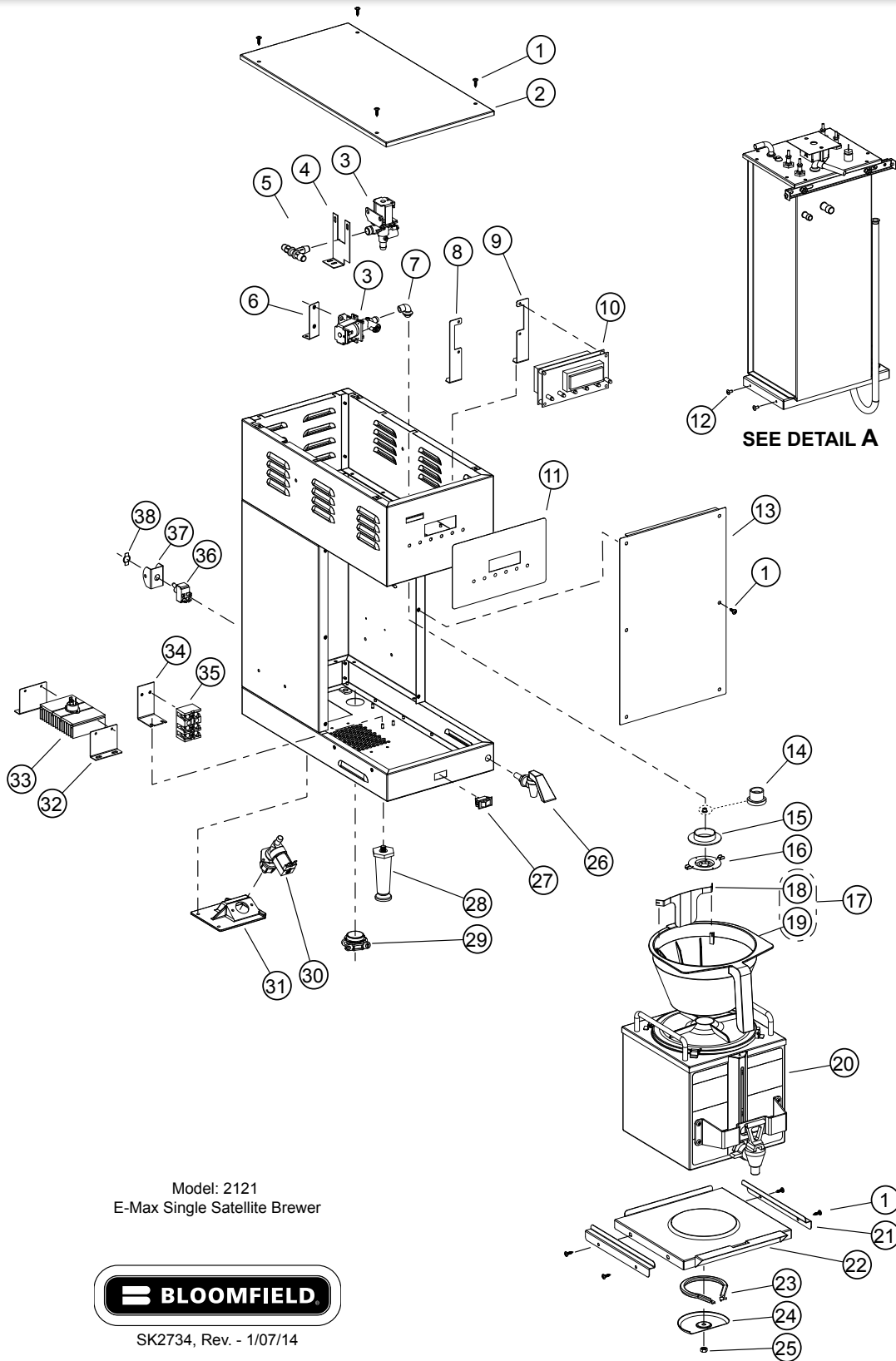

658 2M-217969 Owners Manual 2121 E-Max Satellite Brewer

PARTS LIST : 2121 MAIN ASSEMBLY

Model: 2121 Single E-Max Satellite Brewer			
Fig No	Part No	Qty	Description
1	2C-76007	14	SCREW 8AX1/2 SS TR PH SMS
2	D7-Z16698	1	TOP COVER
3	2V-73388	2	VALVE ADJUST WATER OUTLET
4	D7-Z17807	1	BRACKET, BYPASS
5	2K-74364	1	TEE PLASTIC 1/2 BARB
6	D7-76576	1	BRKT OUTLET VALVE
7	2K-70103	2	ELBOW OUTLET
8	D7-Z16739	1	BRKT BOARD MTG LEFT EMAX
9	D7-Z16740	1	BRKT BOARD MTG RIGHT EMAX
10	2E-Z17751	1	BOARD SET, CONTROL
11	2M-Z17817	1	KEYPAD-SINGLE SATELLITE
12	2C-6349	12	SCREW #8X3/8 B THP STL NP
13	D7-Z16691	1	LOWER FRONT PANEL
14	2G-73571	1	INSERT SPRAY HEAD SS2
15	2I-72215	1	GASKET SPRAY HEAD 1.5 ID
16	A6-72727	1	SPRAY HEAD DISC EMBOSSED
17	D7-76652	1	CHAMBER BREW ASSY
18	D7-Z16812	1	BRKT BYPASS PLASTIC BREW
19	2L-72387M	1	BREW CHAMBER MOLDED BLACK
20	D7-74336	1	SATELLITE ASSY SRL-H
21	D7-74719	2	GUIDE SATELLITE 9441 9442
22	D7-WL0365	1	BASE WARMER COVER ASSY
23	2N-70091UL	1	ELEM WARMER 120V 100W
24	D7-71220	1	RETAINER WARMER ELEMENT
25	2C-35485	1	NUT 1/4-20 HEX FINISHED S
26	2U-71061	1	FAUCET HOT WATER
27	2E-74382	1	SWITCH ON OFF (ROCKER)
28	2A-73098	4	LEG 4 BLK PLASTIC W/FLAN
29	2K-300102	1	STRAIN RELIEF 1NPT.375-1.
30	2V-74427	1	SOLENOID SINGLE 120V 1.0
31	2Q-75089	1	DOOR ACCESS PLASTIC
32	D7-Z16713	2	BRACKET, HEAT SINK
33	2E-73475	1	HEAT SINK AND TRIAC ASSY
34	D7-Z17065	1	BRKT- TERMINAL BLOCK
35	2E-37465	1	TERM BLOCK 3POLE 85AMP
36	2E-30330	1	SWITCH ON OFF TOGGLE 20A
37	Z1-70-07-0343	1	SWITCH GUARD
38	2E-33192	1	PANEL ON & OFF SWITCH
NI	2M-Z17591	1	DIAGRAM WIRE LABEL
NI	2A-76574	1	TUBE BYPASS
NI	2A-74343	1	TUBE FILL 90 DEGREE
NI	F4-73977	1	TUBE SIL .312 ID X 35
NI	A6-73537	3	TUBE SIL .312 ID X 9 LG
NI	D7-Z16477	1	TUBE SILICONE .312 X 41.5
NI	D7-Z18242	1	TUBE SIL .250 ID X .375"
NI	D7-Z18243	1	TUBE SIL .312 ID X 1" LONG
NI	2A-73384	1	TUBE SPRAY HEAD 2 3/8 LG
NI	D7-Z17081	1	TUBE, SIL .500 ID 8.5

EXPLODED VIEW: 2121 TANK ASSEMBLY

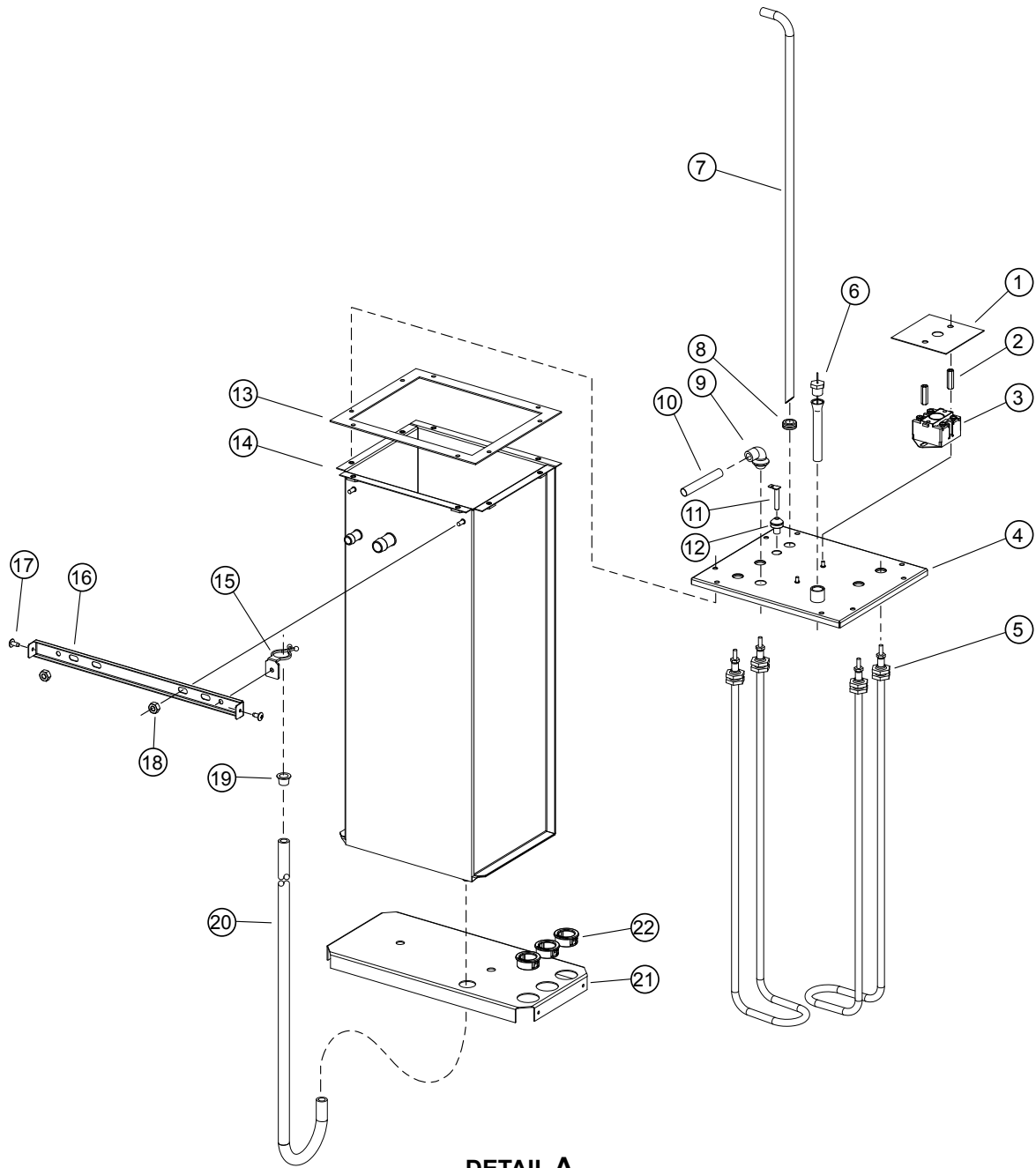

DETAIL A

Model: 2121
E-Max Satellite Brewer: Tank Assy



SK2735, Rev. - 1/07/14

658 2M-217969 Owners Manual 2121 E-Max Satellite Brewer

PARTS LIST: 2121 TANK ASSEMBLY

Detail A: 2121 Tank Assy			
FigNo	Part No.	Qty	Description
1	D7-73414	1	SHIELD HI-LIMIT
2	2C-73415	2	NUT 6-32 HEX 1.00 LG ALUM
3	2T-73312	1	THERMO HI LIMIT DBL POLE
4	D7-WL0347	1	TANK COVER ASSY
5	2N-76571UL	2	ELEM HEATIN 120V 1500W HW
6	2J-73313	1	PROBETHERMISTORPASSIVATE10-1/2"
7	2A-74343	1	TUBE FILL 90 DEGREE
8	2I-72390	1	GROMMET .375 ID TRANSLUCE
9	2K-70103	2	ELBOW OUTLET
10	2A-73384	3	TUBE SPRAY HEAD 2 3/8 LG
11	A6-73521	1	PROBE ASSY WATER LEVEL
12	2A-73532	1	SLEEVE WATER LEVEL PROBE
13	2I-Z16545	1	TANK GASKET
14	D7-WL0346	1	TANK WELDMENT
15	2C-43914	1	TIE WIRE MTG STUD M4200-2
16	D7-Z16700	1	BRACKET, TANK TOP
17	2C-6349	2	SCREW #8X3/8 B THP STL NP
18	2C-35485	2	NUT 1/4-20 HEX FINISHED S
19	2P-306831	1	CAP PLUG PLASTIC .5 DIA.
20	F4-73977	1	TUBE SIL .312 ID X 35
21	D7-Z16694	1	TANK SUPPORT BOTTOM
22	2K-Y5093	3	BUSHING-SNAP #SB-1000-12
NI	2C-76564	1	CLAMP HOSE SHUT OFF

WIRING DIAGRAM: 2121-120/240V SINGLE E-Max SATELLITE BREWER

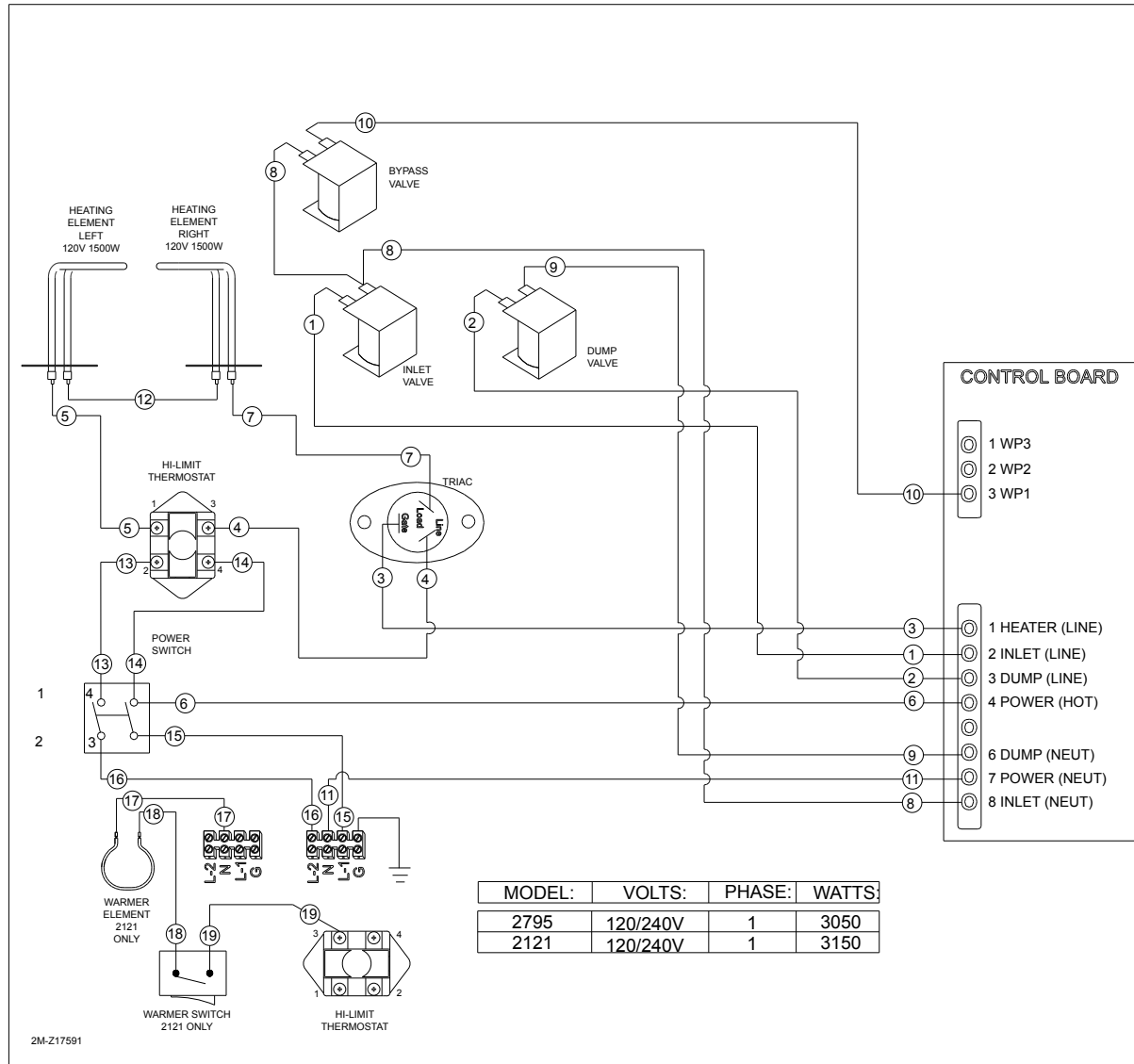

658 2A 671 2M-Z16955 Owners Manual 9121, 9221 Dual Satellite Brewer

CFESA

Commercial Food Equipment Service Association

Wells Bloomfield proudly supports CFESA
Commercial Food Equipment Service Association

SERVICE TRAINING - QUALITY SERVICE



CUSTOMER SATISFACTION

BLOOMFIELD®

10 Sunnen Drive, St. Louis, MO 63143
telephone: 314-678-6336 fax: 314-781-2714
www.bloomfieldworldwide.com