

# Dialog 4220 Lite/Dialog 4222 Office

System telephones for MD110 Communication System

## User Guide



Flinders University

# Table of Contents

Description .....	2
Incoming Calls.....	10
Outgoing Calls.....	12
During Calls.....	18
Call Forwarding.....	23
Group Features.....	33
Other Useful Features.....	35
Settings.....	38
Accessories.....	45
Installation.....	49
Glossary.....	55
Index.....	56

# Description

## Dialog 4220 Lite/4222 Office phones

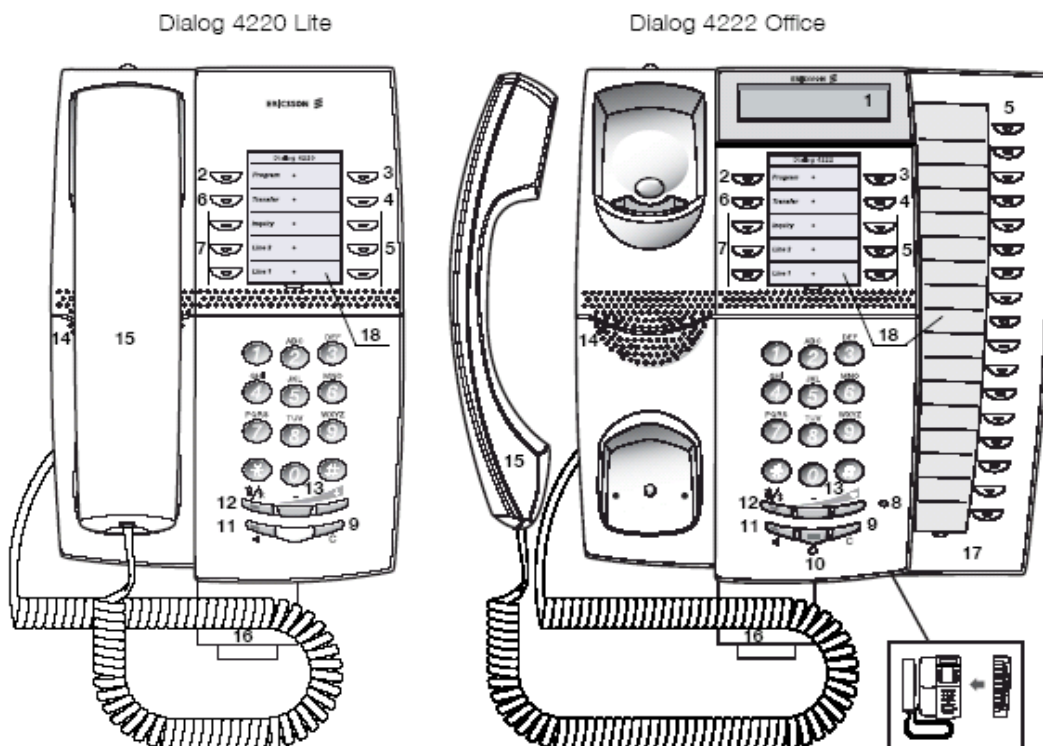

**Note:** The functions available on each model vary. If any functions differ or are unavailable, this will be indicated in the relevant section of the user guide.

- 1 Display (Dialog 4222 Office Only)**  
2x20 characters. See section "Display information" on page 7.
- 2 Programming**  
See Section "Settings" on page 38.

- 3 Call-back**  
For indicating/activating Call-back. See Section “When you receive a busy tone” on page 14. The feature can be removed or moved to another programmable function key by your system administrator.
- 4 Diversion (Follow-me)**  
For indicating/activating and deactivating Diversion (Follow-me). See section “Call Forwarding” on page 23. The feature can be removed or moved to another programmable key by your system administrator.
- 5 Programmable function keys**  
To program numbers of functions, see section “Programming of function keys” on page 38.
- 6 Transfer**  
For transferring call, see section “During Calls” on page 20.
- 7 Triple Access Line**  
For handling calls, Line 1 and 2 are available both for incoming and outgoing calls. Inquiry can only be used for outgoing calls.
- 8 Microphone (Dialog 4222 Office only)**  
Used for handsfree conversation.
- 9 Clear**  
To disconnect calls or exit a function. Can always be pressed instead of replacing the handset.
- 10 Headset Key**  
To handle headset calls.
- 11 Loudspeaker on/off**
  - a. To activate Group listening. See section “During Calls” on page 18.
  - b. To activate handsfree conversation (Dialog 422 Office only see section “During Calls” on page 13.

- 12 Mute**
- a. To switch the microphone on or off during call. See section “Mute” on page 19.
  - b. To switch off the ring signal in idle more or when ringing. See sections “Mute ring signal” on page 43 and “Silent ringing” on page 44.
- 13 Volume control**  
To change the volume. See section “Settings” on page 38.
- 14 Loud Speaker**
- 15 Handset**  
Supplied with hearing aid function as standard. An extra handset can be connected, see section “Accessories” on page 45.
- 16 Pull-out leaf for easy guide (optional)**
- 17 Key panel (optional, Dialog 4222 Office Only)**  
With 17 programmable keys. One panel can be connected. See section “Key panel (optional)” on page 45.
- 18 Designation Card**  
Your system administrator can print new designation cards for you.

# Lamp Indicators



Extinguished lamp

The function is not active.



Steady light

The function is active or multiple represented line is busy.



Slowly flashing lamp

The line (or function) is put on hold.



Rapidly flashing lamp

An incoming call.



Light with short breaks











Ongoing call.

# Tones and Signals

The following different tones and signals are sent from the exchange to your phone.



## Tone characteristics

The tones shown in this section are the most used tones worldwide. Many markets use a different tone for one or more situations.

Dial tone	
Special dial tone	
Ringing tone or queue tone	
Busy tone	
Congestion tone	
Number unobtainable tone	
Call waiting tone	
Intrusion tone	
Conference tone	 every 15 seconds (to all parties)
Verification tone	
Warning tone, expensive route	

## Ring Signals

Three different ring signals inform you about the type of the incoming call. The signals shown in this section are the most used signals worldwide. Many markets use signals that are adapted for the local standards.

Internal ring signal	
External ring signal	
Recall signal (Callback reminder)	

# Display Information

**Notes:**

*The Display is only available on the 4222 Office Phone.*

*There are two versions of display text, an earlier and a later version. Both versions are shown in this section.*

*The order in which the date is stated is system dependent.*

The display gives you feedback information such as time and date, traffic state and connected phone numbers. The following displays show examples of the different states your phone is in.

For the later display text version:

When information ends with three dots (...), this means that the system is working or waiting for your action. When information ends with an exclamation mark (!), this means that no further action is possible.

## **Idle phone (idle mode)**

When your phone is idle, the upper row shows general information. The lower row shows your extension number. In example below, the extension number is 2222.

Earlier version:

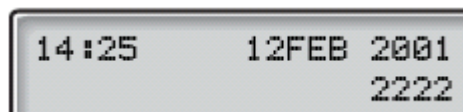

```
14:25      12FEB 2001
                2222
```

Later version:

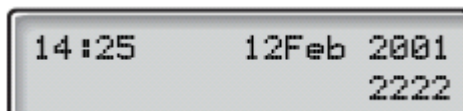

```
14:25      12Feb 2001
                2222
```



### Outgoing call

When you make an outgoing call on your phone, the upper row shows the traffic state and the lower row shows the dialled number.

Earlier version:

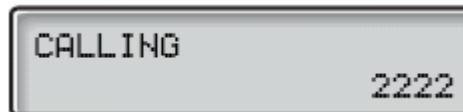

CALLING  
2222

Later version:



Calling...  
2222

If the called party's phone is diverted, the upper row shows the dialled number and Diversion information. For the later version, > is the Diversion symbol.

Earlier version:

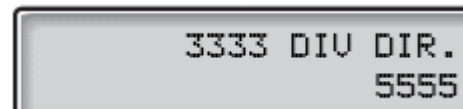

3333 DIV DIR.  
5555

Later version:



3333 >Direct  
5555

The dialled number (3333) is directly diverted to number 5555.

**Incoming call**

When you receive an incoming call, the upper row flashes the calling party's extension number.



If a diverting extension is calling, the upper row shows the diversion information. The calling party's number is flashing on the lower row. For the later version, > is the Diversion symbol.

Earlier version:



Later version:

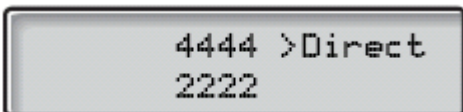

Number 2222 has dialed number 4444 and the call is directly diverted to you.

**Choice of Language(optional)**

One of the following languages can be chosen to be used for the display information on your phone.

Digit 0-9 =the language code:

0 English	1 French	2 German	3 Spanish	4 Italian
5 _____	6 _____	7 _____	8 _____	9 _____

*Note: By default 5-9 are programmed for English. To be changed locally to other languages.*

To choose a language:

✖08✖

Dial.

(0-9)

Enter the language code.

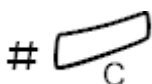

Press.

# Incoming Calls

## Answer calls

A ringing signal and a flashing lamp indicate an incoming call.

### On line 1

Normally you will receive calls on Line 1.



**Lift the handset.**

### On any other Line key



**Lift the handset.**



**Press the flashing line key**

### Handsfree

*(Dialog 4222 Office phone only)*



**Press the flashing line key.**

You are connected to the caller via the loudspeaker and the microphone.

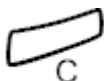

**Press to terminate a handsfree call.**

**On another extension**

You can answer a call to a phone in another room.



**4**

**Call the ringing extension****Press****Notes:**

*You can also press Call pick up (function key programmed by system administrator).*

**Answer a second call during and ongoing call**

If your phone is programmed with a Free on 2<sup>nd</sup> key, you can receive another call, if this function is activated.

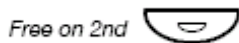
**Press to activate/deactivate.**

When Free on 2 is active lamp is lit.

*Note: Function Key programmed by your system administrator.*

You have an ongoing call Line 1, when Line 2 flashes to indicate a new incoming call:

**Press to answer.**

The first call is put on hold

**Press to switch back to the first call**

The second call is put on hold. You are connected to the first caller.

**Press to terminate the connected call**

# Outgoing Calls

## Make calls

How to make internal and external calls:



**Lift the handset and proceed depending on call type:**

### Internal calls



**Dial the extension number.**

### External calls

**0**

**Press the digit or digits to get an external line.**

Dial tone.



**Dial the external number.**

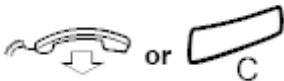

**Replace the handset or press to end the call.**

***Note:** If you receive a queue tone when the digit or digits to get an external line are dialled (optional function Least Cost Routing is used in the system), keep waiting. Once a line becomes free you will receive a dial tone. If a warning tone is heard, the selected line is marked "Expensive".*

## **Handsfree**

*(Dialog 4222 Office phone only)*



### **Dial the number**

You are connected via the loudspeaker and the microphone.



### **Press to terminate a handsfree call.**

***Note:** You can make your calls faster by using common Speed dialling numbers and by using your own programmed function keys. See section "Speed Dialling" on page 15.*

---

## **Last External Number Redial**

When you initiate an external call the system automatically stores all the dialled digits, irrespective of whether the call was successful or not.



### **Lift the handset**

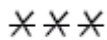

### **Dial to repeat the stored number.**

The last external number is automatically redialled.

**Notes:**

*You also press Last Number Redial (function Key programmed by the system administrator).*

## When you receive a busy tone

If you call an extension and receive a busy tone, or get no answer you can use any of the following methods.

### Call-back

If a called extensions is busy or there is no answer:

6

#### Press

It can take a couple of seconds before the procedure was executed.

#### **Notes:**

*You can also press: Call-back (function key programmed by system administrator).*



#### Replace the handset to finish procedure

You are called back (recall ringing signal) when the ongoing call is finished or the next time a new call is finished. You have to answer within 8 seconds; otherwise the Call-back service is cancelled. While waiting for Call-back you can make and receive calls as normal.



#### Lift the handset when you are called back

The system calls the ext.

**Note:** *Call-backs can be activated on several extensions at the same time. Call-backs from additional lines will recall on Line 1.*

### Cancel any single Call-back

# 3 7 \*

Dial and enter the ext number.

#

Press

### Cancel all Call-backs

# 3 7 #

Dial

Press

## Bypass

If this function is allowed from your extension, you can bypass an; *activated diversion or activated follow me* on a specific extension.

✳ 60 ✳ 

**Dial and enter the extension number.**

#

**Press and wait for answer.**

## Speed Dialling

### Common Speed Dialling numbers

By using common speed dialling numbers, you can make calls simply by pressing a few keys. The common speed dialling numbers consist of 1-5 digits and are stored in the exchange by your system administrator.



**Lift the handset and dial the common Speed Dialling number.**

### Individual Speed Dialling numbers

You can program ten frequently used phone numbers on the digit keys 0-9 and use them as individual Speed Dialling numbers (if this function is allowed).

To use:

✳✳ (0-9)

**Dial and press the relevant digit.**

To program and alter Individual Speed Dialling numbers:

✳51✳ (0-9)

**Dial and press the selected digit.**

✳ 

**Press and dial the phone number**

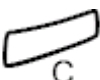
# 

**Press**



**Note:** The programmed number may consist of a maximum of 20 digits plus \* which indicates the second dial tone from the public network.

To erase one programmed number:

# 5 1 \* (0-9)

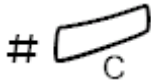

**Dial and press selected digit.**

**Press**

To erase all programmed numbers:

# 5 1 #



**Dial**

**Press**

**Dial by a function key**

Both functions and phone numbers can be programmed on a function key. To programme a key, speak to your system administrator.

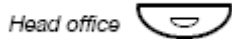

**Press the function key.**

**Authorisation Code (Optional)**

If you are assigned an authorisation code (1 to 7 digits), affiliated to your own ext you can change the access level on your ext. You can use the code for one call or you can open the phone to some calls and lock it when leaving the phone.

To use for a single call:

**\*72\***

**Dial.**

⓪⓪⓪  
⓪⓪⓪ #  
⓪

**Enter authorisation code and press**  
Verification tone.

⓪⓪⓪  
⓪⓪⓪  
⓪⓪⓪  
⓪

**Dial 0 to get an external line, and then dial the**  
**external number.**

To open an ext for some calls:

**#73\***

**Dial**

⓪⓪⓪  
⓪⓪⓪ #  
⓪

**Enter authorisation code and press.**  
Verification tone.

To lock an extension:

**\*73\***

**Dial**

⓪⓪⓪  
⓪⓪⓪ #  
⓪

**Enter authorisation code and press.**  
Verification tone.

# During Calls

## Group Listening (Loudspeaking)

This function lets other people in your room listen to your phone conversation. You speak in the handset while the other party's voice is heard on the speaker.

During an ongoing conversation:



**Press to switch between loudspeaker and handset.**

When the key lamp is lit, the other party's voice is heard on the loudspeaker.

*Note: You can adjust the volume, See section "Settings" on page 38.*

### **From loudspeaking to handsfree**

(Dialog 4222 Office phone only).



**Replace the handset.**

Handsfree conversation

### **From handsfree to loudspeaking**

(Dialog 4222 Office phone only).



**Lift the handset and press.**

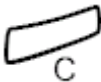

**Press to end the call.**

## Handsfree

(Dialog 4222 Office phone only).



**Press and replace the handset**  
Handsfree conversation



**Press to end the call.**

### From handsfree to handset



**Lift the handset**  
Conversation via the handset

## Mute



**Press to switch the microphone on or off.**  
When the lamp is lit, the person on the line cannot hear what is being said in your room.

## Inquiry

You have a voice connection on Line 1 and want to make an inquiry to an internal or external party.



**Press**  
This first party is put on hold (Line 1 flashes slowly).

*Note: You can also press Line 2*



### Call the Third Party

When the other party answers, you can switch between the calls, Transfer the call, create a conference and end one of the calls.



**Press to end inquiry or call.**  
The third party is disconnected



**Press to return to first call.**

### **Refer Back**

The line key flashes for the call put on hold.



Line 1

#### **Press to put third party on hold.**

First call is connected.



Inquiry

#### **Press to put first call on hold**

Third party is connected.

*Note: You can also press Line 2 if you have initiated the inquiry on line 2.*



#### **Press to terminate connected call.**

---

## **Transfer**

You have an ongoing call and you want to transfer the call to another extension.



Inquiry

#### **Press**

*Note: You can also press a free line key.*



#### **Call the third party**



Transfer

#### **Press before or after**

The ongoing call is transferred.

*Note: If you have put more than one call on hold, the last call that was put on hold will be transferred. If the dialled ext is busy or Transfer is not allowed, your phone will ring again.*

## Conference

With this procedure you can include up to seven parties in a conference. Only the conference leader (i.e. the person initiating the conference) can admit participants. During the conference a tone will be heard every 15<sup>th</sup> second.

You have an ongoing conversation (Line 1) and want to establish a phone conference. You will become the conference leader.



**Press.**

*Note: You can also press Line 2 or Inquiry*



**Call the third party.**

Wait for an answer.

**3**

**Press to establish conference**

**Repeat the procedure to add more conference members.**



**Replace the handset to leave the conference.**

*Note: A tone burst is heard each time a participant enters or leaves the conference. When the conference leader leaves the conference, the conference will continue with the other included parties. The conversation is changed back to a normal 2 party connection when there is only two parties left.*

## On Hold

You can temporarily put the ongoing call on hold. Calls put on hold can be resumed from your own phone.

### Individual

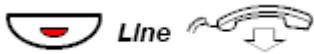

**Press the ongoing call Line key and replace the handset.**

The key lamp flashes slowly.



**Press the flashing Line again to resume the call.**

# Call Forwarding

## Diversion

If you do not want to be disturbed or will be out of the office, you can have all calls diverted to another answering position. During diversion you will hear a special dial tone. You can still make calls as usual.

Diversion can be direct, on no answer or on busy.

### Order Direct Diversion from your ext

The call is diverted to an individual position, pre-programmed by your system administrator.

**Note:** Diversion can also be ordered or cancelled from the answering position, use same procedure as in section "Internal follow-me" page 25.

Diversion 

### Press

**Note:** Function key programmed by your System administrator. Lamp will be lit.

\*21# 

### Dial and press.

### Cancel Direct diversion from your own ext

**Note:** Diversion can also be ordered or cancelled from the answering position, use same procedure as in section "Internal follow-me" page 25.

Diversion 

### Press

**Note:** Function key pre-programmed by your system administrator. You can also use procedure below.

#21#

### Dial.





**Press.**

*Diversion when there is no answer*

**\*211#**

**Dial to order.**

The incoming call is diverted after 3 rings.



**Press.**

**#211#**

**Dial to cancel.**



**Press.**

*Diversion when caller receives busy tone*

**\*212#**

**Dial to order.**



**Press**

## Internal Follow-me

All calls to your extension are diverted to another extension of your choice (within the private network). During the follow-me, your phone can still be used for outgoing calls and you will hear a special dial tone when you lift the handset.

### Order from your own extension



**Lift the Handset**

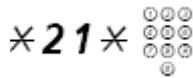

**Dial and enter the answering position**

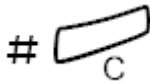

**Press**

### Cancel from your own extension

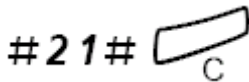

**Dial and Press**

### Redirect from answering position

If you move from one answering position to another answering position, you can redirect Follow-me from that new position.

**Note:** *Internal Follow-me must be ordered from your own extension before you can redirect from answering position.*

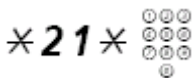

**Dial and enter your own extension number.**



**Press and enter the diversion number**

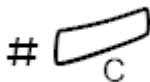

**Press to redirect**

Calls are diverted to answering position.

Cancel from answering position

#21\* 

Dial and enter your own extension number.

# 

Press.

---

**External Follow-me**

If external Follow-me is allowed, you can have all calls to your extension diverted to an external number of your choice. During Follow-me, your phone can still be used for outgoing calls and you will hear a special dial tone when you lift the handset.

Order

\*22# 

Dial and enter the digit or digits to get an external line and enter the external line.

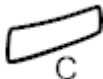
# 

Press.

Cancel

#22#

Dial



Press

## Personal Number (optional)

With this function you can be reached on your normal office phone number even if you are in another room, out of the office or at home, etc.

Depending on the functionality of your office exchange, you can have either one individual single search profile or you can choose between five individual search profiles.

A search profile can be designed to fit the situation, i.e. in the office, travelling, at home, etc. Both internal or external phone numbers can be used in a profile.

At your request, the search profiles are programmed or modified by your system administrator. See section "To design and order your search profiles" on page 32.

When the function is activated, incoming calls are transferred to different phones or to back up services in the order you choose. If an answering position in the profile is busy, the call can be transferred to another predefined position in the profile, i.e. voicemail or a colleague. You can activate the function from your own office phone or when out of the office, by using the Direct Inward System Access Function (DISA).

To activate or change to another profile from your office phone.

× 1 0 ×

**Dial**

( 1 - 5 )

**Press the search profile digit.**

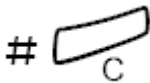

**Press.**

The display show the chosen search profile digit.

### Notes:

*You can also activate and change to another profile by programming one function key/search profile (pre-assigned by your system administrator). When the search profile is active the key lamp is on. See section "Settings" on page 38. When another party is included in the activated profile, a colleague or an operator etc., remember to inform about your absence.*

To Cancel from your office phone

# 1 0 #

**Dial.****Press**

**Note:** If you have activated a profile via function key, you can press this key instead of using the procedure above.

To activate or change to another profile from an external phone

The external phone must be of push button type provided with the hash key (#) and star key (\*) or a mobile phone adapted for dial tone pulses (DTMF).

**Call the DISA function at your office.**

Dial tone.

\* 7 5 \*

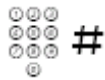
**Dial****Enter the authorisation code and press.****Dial your own ext number and press.**

Dial tone.

\* 1 0 \*

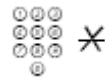
**Dial****Dial your own extension number and press.**

( 1 - 5 )

**Press the search profile digit.****Press and replace the handset.**

**Note:** When another party is included in the activated profile, a colleague or an operator, etc., always remember to inform about your absence. If voicemail is included in the activated profile, always update your greeting with absence information.

To cancel from an external phone

The external phone must be of push button type provided with the hash key (#) and star key (\*) or a mobile phone adapted for dial tone pulses (DTMF).



**Call the DISA function at your office.**

Dial tone.

×75×

Dial tone.

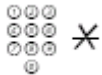

Dial the authorisation code and press.

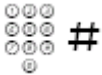

Dial your own extension number and press.

Dial tone.

#10×

Dial

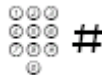

Dial your own extension number and press.



Replace the handset

To design and order your search profile

The search profiles are installed or changed by your system administrator. In order to set up your profiles, copy the setting form, fill in your new or changed profiles and hand in to your system administrator.

### Important notes when designing your profiles:

- Avoid ring times longer than 45 seconds for your profiles

Usually the caller hangs up after 3-6 ring signals. If you need a longer ring time, the maximum ring time is 60 sec.

- Consider the time you need to react and answer on each answering position on your profile.

You might need up to 15 seconds to react and answer a call on a desk or cordless phone and 20-25 seconds for a mobile phone.

- There must be an answering position at the end of every profile. (Voicemail or operator/secretary)

If not, calls might end up unanswered.

- Consider what should happen when you are busy on the phone:

The available options are:

- Activate Free on 2<sup>nd</sup> (if available)
- Diversion to voicemail
- Diversion to operator

- If an answering machine, a fax or other answering device is used as an early answering position, it might interrupt the searching.

Disconnect the answering device, or design the ring time so that they do not affect the searching.

- If your system admits just one single profile, design the profile only with your 2-3 most frequently used positions.

If you add more numbers, there is a risk that the caller hangs up before a latter position is called.

- If your system admits 1-5 personal profiles, design the different profiles to fit your most frequently used positions.

Make sure you use as few answering positions as possible for each profile. Profile examples:

- In the office
- At home
- Travelling
- Absent/not reachable

*Example:*

How to fill in your setting form for search profiles:

**Profile 1 In office**

Search order	Type of telephone or Answering position*	Telephone number	Ring time (seconds)
1	Desk	1234	10
2	Cordless	5234	15
3	Voice mail		

\* Examples: Desk, Cordless, Mobile, External, Voice mail, Operator, etc.

**Profile 2 At home**

Search order	Type of telephone or Answering position*	Telephone number	Ring time (seconds)
1	External	222222	20
2	Mobile	0706666666	25
3	Voice mail		



## Setting form for Search profiles

Name:

Department:

Telephone no.:

### Profile 1

Search order	Type of telephone or Answering position*	Telephone number	Ring time (seconds)
1			
2			
3			
4			

\* Examples: Desk, Cordless, Mobile, External, Voice mail, Operator, etc.

### Profile 2

Search order	Type of telephone or Answering position*	Telephone number	Ring time (seconds)
1			
2			
3			
4			

### Profile 3

Search order	Type of telephone or Answering position*	Telephone number	Ring time (seconds)
1			
2			
3			
4			

### Profile 4

Search order	Type of telephone or Answering position*	Telephone number	Ring time (seconds)
1			
2			
3			
4			

### Profile 5

Search order	Type of telephone or Answering position*	Telephone number	Ring time (seconds)
1			
2			
3			
4			

# Group Features

## Group Call-pick-up

People working in a team can have their phones programmed by the system administrator to form a call-pick-up group.

In a call-pick-up group, any member can answer any individual call to group members.

**6**

**Press to answer.**

---

## Common bell group

Calls are signalled on a common bell.

**88**

**Press to answer.**

---

## Group Hunting

An internal Group Hunting number is common directory number for a group of extensions. Calls to the group will be indicated at a free extension in the group.

When you leave your phone temporarily, you make your phone unavailable for incoming calls.

To leave a group temporarily

✖21✖ 

**Dial and enter in your own extension.**

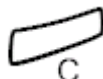
# 

**Press**

To re-enter the group

#21#

Dial



Press.

If you are authorised you can you can divert all calls to your group, to another extension or group:

\*24\*

Dial



Dial the number of the group to be diverted and press.



Dial the extension number of the new answering position.



Press

To cancel the diversion:

#24\*

Dial



Dial the number of the group that has been diverted.

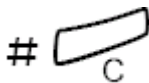

Press

# Other useful features

## General deactivation

The following features can be simultaneously cancelled :

- Call-back (all call-backs are cancelled)
- Diversion/Internal and External Follow-me

### Order

#001#



Dial

Press

---

## Hot line

Ask your system administrator if you require this function.

### Delayed Hot Line

When the handset of the delayed hot line phone is lifted or when the line key is pressed, a timer is started. If no digit is pressed before time out, a call is generated to a specific extension or external line. If a digit is pressed before time out the phone works as an ordinary phone.

### Direct Hot Line

The same function as described above, but without a delay. Only hotline calls can be placed from this line. To be used e.g. as alarm phone, door phone etc

## Additional directory number

You can be assigned (programmed by your system administrator) one or more Additional Directory Numbers (lines) on three function keys.

To answer, make calls and use functions on the additional directory lines, use below procedure.

*Example:*

To make a call on an additional directory line:



**Lift the handset**

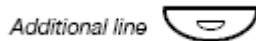

**Press**

**Note:** *Function key pre-programmed by your system administrator.*



**Dial the extension**

## Multiple represented directory number

Your extension number can be programmed on a dedicated key on other system telephones, i.e. the number is “represented” on these phones.

This means that incoming calls to your extension can be answered on any of these other phones by just pressing the dedicated key. The dedicated key can also be programmed with the possibility to call your extension when pressed. This function has to be programmed by your system administrator.

## **DISA = Dialling Inward System Access (Optional)**

If you are assigned to use this function and you are working externally, you can call your office and get access to an external line in order to make business calls. The business call will be charged to your extension number or an account number. You will just be charged for the call to the office.

The external phone must be off push button type provided with the hash key(#) and star key (\*) or a mobile phone adapted for dial tone pulses (DTMF).

After a completed DISA call you must hang up before a new DISA call can be made.

### With Authorisation code



**Call the DISA function at your office**

Dial tone

✳ 72 ✳

**Dial**

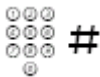

**Dial the authorisation code and press**

Dial tone



**Dial the external number**

# Settings

## Programming of function keys

Frequently used functions and phone numbers can be Programmed of the function keys for easy access. When you want to use the function just press the key. Certain functions must be programmed by your system administrator. Both phone numbers and function can be programmed on a function key.

### Programme or change a function



**Press**



**Press selected function key**

*Note: If the key is already programmed the number or function will be displayed.*



**Enter phone number or function code according to the list in section “Functions and required data”.**

*Note: If a wrong number is entered, press the clear key to erase it, and then enter the number again.*



**Press the function key again.**

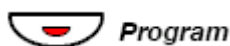

**Press to finish programming.**

Remove the transparent cover and write the function name or phone number beside the key

To verify and erase programmed number or function

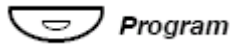

**Press.**



**Press the selected function key.**

On the 4222 office phone, the stored number is shown on the display.



**Press if you want to erase the stored number.**

The stored number is erased.



**Press.**



## Functions and required data

<i>Function</i>	<i>Function code or associated number</i>
Call Pickup:	
Group	<b>6</b>
Individual	<b>No. + 4</b>
Conference:	<b>3</b>
Dial by function key	<b>Extension number</b>
Last external number redial	<b>***</b>
Personal Number (List no,)	<b>1-5</b>

Functions that need to be programmed by your system administrator:

- Additional lines
- Free on 2nd
- Multiple Representation
- Search profile lists and pre-assigning of function keys for Personal Number.
- Call-back
- Diversion
- Individual external line

## Programming of ringing signals

You have six programmable ring tones on your phone. The different signals can be programmed on lines, additional lines and multiple represented lines.



**Press**



**Press the corresponding Line key.**

**(0-6)**

**Select the ring signal you want to use according to the list below:**

- 0 = Silent
- 1 = Periodic ring signal.
- 2 = Delayed periodic ring signal
- 3 = One muted ring signal
- 4 = One muted delay ring signal
- 5 = Immediate Speech Connection with one ring signal controlled by function key
- 6 = Immediate Speech Connection with one ring signal.

*Note: Options 5 and 6 are not available for multiple represented lines.*



**Press**



**Press to finish programming**

To verify a ring signal

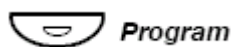

**Press**



**Press the corresponding Line key.**

A digit (0-6) is shown in the display.

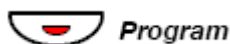

**Press to finish programming.**

## Programming of signal tone character

There are 10 different programmable ring signal tone characters on your phone, each corresponding to a digit between 0 and 9.

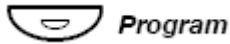

### Press

On the 4222 Office phone, the current tone character is displayed.

(0-9)

### Press the corresponding digit.

The phone rings with the chosen character.



### Press to finish programming.

## Handset and Loudspeaker Volume

Use the Volume keys to change the volume of the handset or loudspeaker during a call. Adjust the handset listening volume when the handset is off the hook. Adjust the loudspeaker volume when dial tone is heard via the loudspeaker.



### Press to change the volume.

On the dialog 4222 Office phone, a volume symbol is shown for a few seconds (replacing your extension number). The handset and loudspeaker level is stored.

To adjust the volume during group listening:



### Replace the handset.



### Press to change the volume.

Volume symbol is shown for a few seconds.



### Lift the handset and press.

For people with impaired hearing, the handset hearing volume can be extra amplified. To change the level:

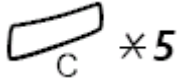

**Press simultaneously for at least 1 sec.**

A tone is heard, and the display on the 4222 office phone shows "Setting Mode".



**Press to set or reset the volume level.**

Key lamp on indicates amplified volume level. Key lamp off indicates default volume.



**Press to finish setting.**

When extra amplification has been selected the Line 1 key turns off.

*Note: A level change also effects a headset connected to the headset outlet.*

## Ring signal volume

Use the Volume keys to adjust the ring signal volume when the phone is idle or ringing. Adjusted volume is stored.



**Press to change the volume.**

On the dialog 4222 Office phone, a volume symbol is shown for a few seconds (replacing your extension number).

## Mute ring signal

You can suppress the ring signal for an incoming call.



**Press to switch the ring signal.**

The ring signal is switched off for the current call, and your phone is automatically set to silent ringing.

## Silent Ringing

If you do not want to be disturbed by the ring signal but still want to be able to answer an incoming call, you can switch off the ring signal. Incoming are only indicated by the flashing line lamp and display information.

When the phone is in idle mode or when ringing:



### Press to switch off the ring signal

The mute key lamp is switched on to indicate silent ringing. The ring signal will automatically be switched on the next time you lift the handset or press any key.

## Display Contrast

*(Dialog 4222 Office phone only)*

You can adjust the contrast of the display.

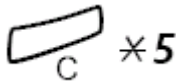

### Press and hold simultaneously until ring signal is heard.

The display shows "Settings Mode".



**Press.**



**Press repeatedly to adjust the contrast.**

**#**

**Press to save and exit.**

**Note:** To exit the menu without saving changes, press # before you press any of the adjustment keys.

# Accessories

## Key Panel (Optional)

*(Dialog 4222 Office phone only)*

In newer versions of the exchange, your phone can be equipped with one additional key panel. The key panel offers 17 additional keys for sorting of your most frequently used telephone numbers and functions, and for supervising extensions. If you don't know what version of the exchange you are using, ask your system administrator. How to install the key panel, see section "Installation" on page 49.

---

## Headset (Optional)

*(Dialog 4222 Office phone only)*

How to install the headset, see section "installation" on page 49. The following headset functions are available.

### Answer calls



#### **Press to answer**

Headset lamp is turned on.

**Note:** When the phone is set for "Headset Preset", you can also press the flashing line key to answer the call. See section "Headset Preset" on page 47.

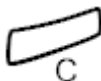

**Press to terminate the headset call.**

Make calls



**Press and dial the number.**  
The headset key lamp is on.

**Note:** When the phone is set Headset preset, you can also dial the number directly without pressing the headset key or press a Line Key instead of the Headset key.



**Press to terminate the call.**

From headset to handset



**Lift the handset**

From handset to headset



**Press**  
The headset key lamp is turned on.



**Replace the handset**

Headset with Group listening (loudspeaking)



**Press to toggle between headset with or without group listening.**  
When the Loudspeaker key lamp is on, the Group is listening is active.

From headset to handsfree



**Press**  
The loudspeaker key lamp is turned on



**Press**

From handsfree to headset**Press**

The headset key lamp is turned on.

Headset Preset

By default the phone is set for calls to be connected to the loudspeaker when you answer or make calls, by pressing a Line key, so called Loudspeaker Preset. Also when you dial the number without lifting the handset, the call is automatically connected to the loudspeaker.

When you use a headset for your telephone, you can change the setting to get calls connected to the headset instead, so called Headset Preset. In Headset Preset mode you can make headset calls by pressing digits directly (direct dialling). You can also answer headset calls by pressing a Line Key.

**Notes:**

*Independent the type of preset setting, when you lift the handset, the call is always connected to the handset.*

*Also handsfree and loudspeaking work as usual, i.e. when the Loudspeaker key is pressed, the call is temporarily connected to the loudspeaker.*

*Activation and cancellation of Headset Preset can only be done when the telephone is in idle mode.*

To activate Headset Preset:

**Press and hold for at least 4 seconds**

A short acknowledgement tone signal is heard, and the headset key lamp flashes for a few seconds.

To cancel Headset Preset:

**Press to hold for at least 4 seconds**

A short acknowledgement tone signal is heard, and the loudspeaker key lamp flashes for a few seconds.

To check the current preset setting:



**Press**

Either the Loudspeaker or Headset key lamp is turned on, indicating the current preset setting.

**Press**Headset Volume

Use the Volume keys to change the volume of the headset.

**Press to change the volume.**

On the Dialog 4222 Office phone, a volume symbol is shown for a few seconds (replacing your extension number). The set headset volume level is stored.

To adjust the volume for the loudspeaker of the phone during Group listening:

**Press****Press to change the volume.**

On the Dialog 4222 Office phone, a volume symbol is shown for a few seconds (replacing your extension number). The loudspeaker volume level is stored.

**Press.**

For people with impaired hearing, the headset hearing volume level can be extra amplified, use the same procedure as in section "Handset and loudspeaker volume" on page 42.

# Installation

## Install cables

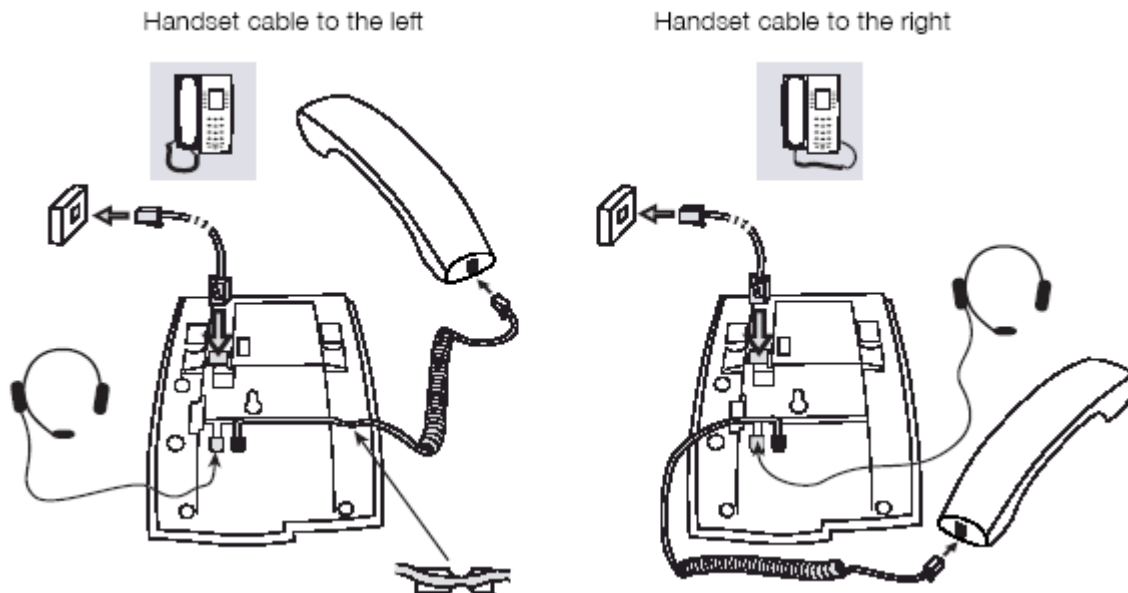

You can put the cable to the handset notch underneath the telephone. The cable to the exchange has to be plugged in "LINE" and the handset cable has to be plugged in "HANDSET".

### Change cables

To remove a cable, use a screwdriver to unlock the stop.

## Install stands and adapt phone

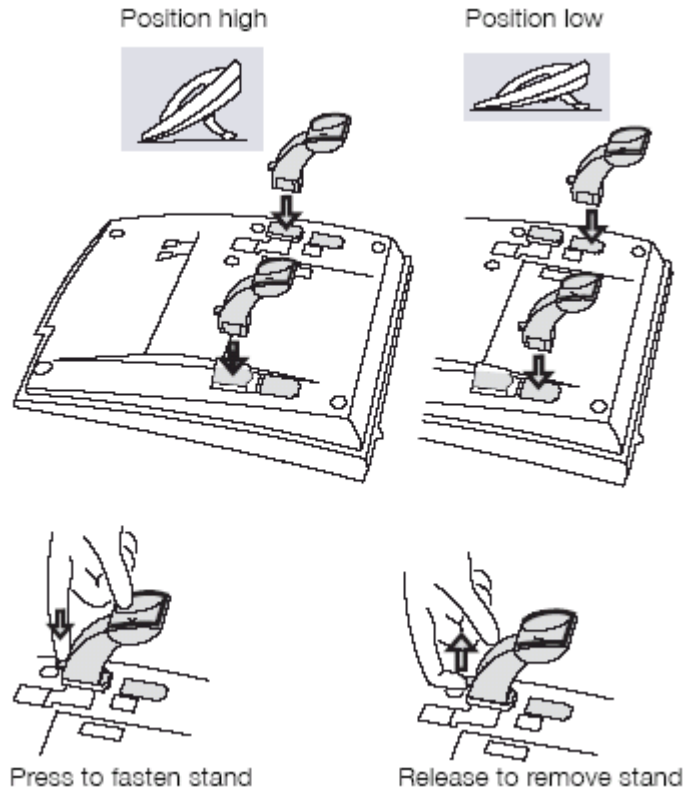

## Install key panel (optional)

*(Dialog 4222 Office phone only)*

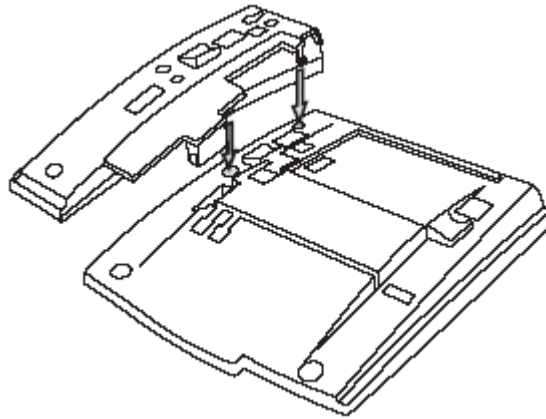

### 1 Attach the key panel unit

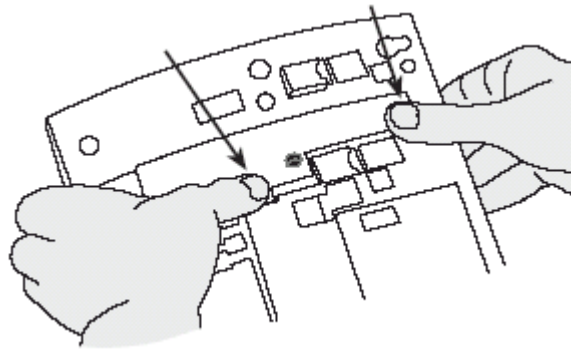

### 2 Press hard where the arrows are pointing, until you hear the "Click" sound.

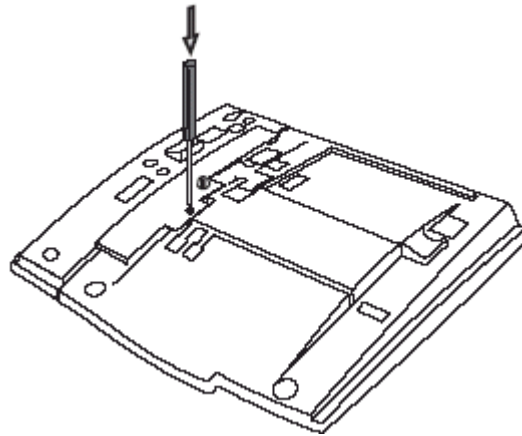

- 3 Use a screw driver and press hard in the bottom of the hole, until you hear a weak sound.
- 4 Install the stands as shown in picture “Stand positioning”

**Stand positioning**

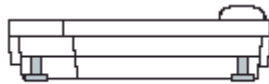

## Wall Mounting

The phone can be wall mounted without using a special console. Useful for instance in conference rooms or public areas.

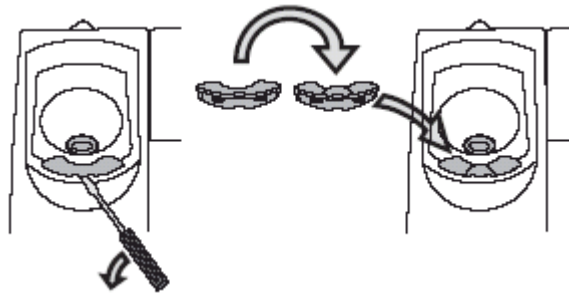

- 1 Use a screwdriver to remove the handset hook.
- 2 Turn the hook upside down and insert

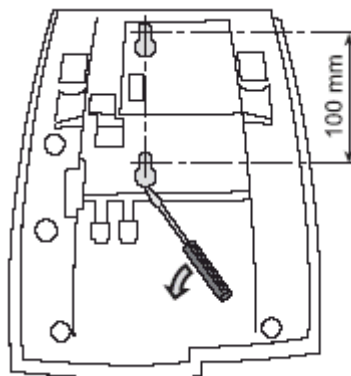

- 3 Use the screwdriver to remove the two plastic covers.
- 4 Drill wall holes according to measure.

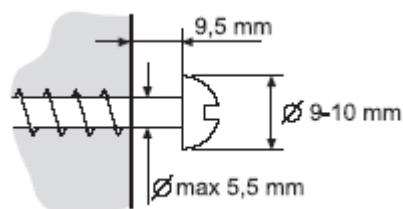

- 5 Mount screws according to measures and attach the phone.

## **Placing the phone**

Do not expose your phone to direct sunlight for long periods. Keep the phone away from excessive heat and moisture.

---

## **Cleaning**

Clean your phone only with soft, water dampened cloth. Using soap or any other cleaning materials may discolour or damage the phone.

# Glossary

<b>Additional Lines</b>	One or more additional extension numbers can be assigned to your phone, these are programmed on free function keys.
<b>Exchange</b>	Switch. Your telephone switching system, e.g. MD110 Communication System.
<b>Idle mode</b>	The state your phone is in when nothing is activated; not calling, not ringing, not diverting etc.
<b>Speed Dialling number</b>	Abbreviated number or short number, used for making frequently used numbers faster to dial.
<b>Supervision</b>	Your extension number can be represented on a function key on other extensions (two or more).
<b>Traffic state</b>	The different stated your phone is in; calling, ringing, diverted, etc.



# Index

## A

- Accessories 45
  - Headset 45
  - Key Panel 45
- Additional directory number 36
- Answer calls 10
- Authorisation Code 17

## B

- Bypass 15

## C

- Call Forwarding 23
  - Diversion 23
  - External Follow-me 26
  - Internal Follow-me 25
  - Personal Number 27
- Call-back 14
- Common Bell group 33
- Common Speed Dialling numbers 15
- Conference 21

## D

- Description 2
  - Choice of language 9
  - Display information 7
  - Lamp Indications 5
  - Tones and Signals 6
- Dial by a function key 38
- DISA=Direct Inward Dialling System 37
- Display information 7
- Diversion 23
- During calls 18
  - Conference 21
  - Group Listening (loudspeaking) 18
  - Handsfree 19
  - Handsfree to loudspeaking 18
  - Inquiry 19
  - Loudspeaking to handsfree 18
  - Microphone on or off 19
  - On hold 22
  - Transfer 20

## E

- External Follow-me 26

## F

- Free on 2<sup>nd</sup> 11
- Functions and required data 40

## G

- General Deactivation 35
- Glossary 55
- Group Features 33
- Group Hunting 33
- Group listening (loudspeaking) 18

## H

- Handset and loudspeaker volume 42
- Handsfree 13
- Headset 45
- Hot Line 35

## I

- Incoming calls 10
  - Answer a second call 11
  - Handsfree 10
  - On another extension 11
  - On any other line key 10
  - On Line 1 10
- Individual Speed Dialling numbers 15
- Inquiry 19
- Installation 49
- Internal Follow-me 25

## K

- Key panel 45

## L

- Lamp indications 5
- Language 9
- Last External Number Redial 13

## M

- Make calls 12
- Multiple represented directory number 36
- Mute 19
- Mute ring signal 43

**O**

- On hold 37
- Other useful features 35
- Outgoing calls 12
  - Authorisation code 17
  - Bypass 15
  - Call-back 14
  - External calls 12
  - Handsfree 13
  - Internal calls 12
  - Last External Number Redial 13
  - Speed dialling 15
  - When you receive a busy tone 14

**P**

- Personal number 27
- Programming of functions 38
- Programming of signal tone character 42
- Programming of ring signals 41
- Put a call on hold 22

**R**

- Refer back 20
- Ring signal volume 43
- Ring signals 6

**S**

- Setting form for search profiles 32
- Settings 38
  - Mute ring signal 43
  - Programming of functions 38
  - Programming of a signal tone character 42
  - Programming of ring signals 41
  - Ring signal volume 43
  - Silent ringing 44
- Speed dialling 15

**T**

- Tones and signals 6
- Transfer 20

**V**

- Volume 42

**W**

- When you receive a busy tone 14