

USER'S MANUAL

Thermal Transfer Bar Code Printer

CLP-7001
CLP-7002
CLP-7401

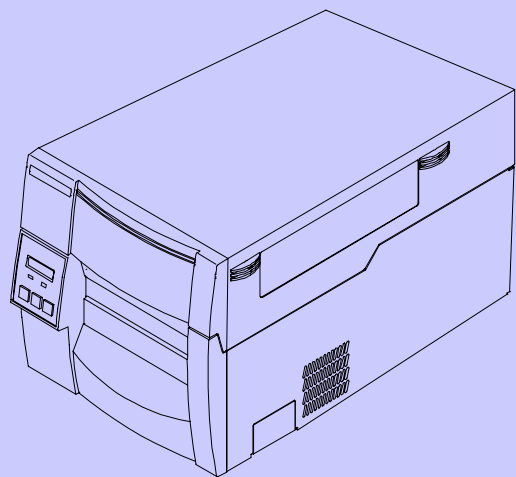

FCC COMPLIANCE STATEMENT FOR AMERICAN USERS

This equipment has been tested and found to comply with the limits for a Class A digital device, pursuant to Part 15 of the FCC Rules. These limits are designed to provide reasonable protection against harmful interference when the equipment is operated in a commercial environment. This equipment generates, uses, and can radiate radio frequency energy and, if not installed and used in accordance with the instruction manual, may cause harmful interference to radio communications. Operation of this equipment in a residential area is likely to cause harmful interference in which case the user will be required to correct the interference at his own expense.

"DESIGNED AND MANUFACTURED TO BE EQUIVALENT TO EUROPEAN
STANDARD FOR ITE, EN60950."

EMI COMPLIANCE STATEMENT FOR CANADIAN USERS

This equipment generates and uses radio frequency energy and if not installed and used properly, that is, in strict accordance with the manufacturer's instructions, may cause interference to radio and television reception. This digital apparatus does not exceed the Class A limits for radio noise emissions from digital apparatus set out in the Radio Interference Regulations of the Canadian Department of Communications. This equipment is designed to provide reasonable protection against such interference in a residential installation. However, there is no guarantee that interference will not occur in a particular installation. If this equipment does cause interference to radio or television reception, which can be determined by turning the equipment off and on, the user is encouraged to try to correct the interference by one or more of the following measures:

- Reorient or relocate the receiving antenna.
- Increase the separation between the equipment and receiver.
- Connect the equipment into an outlet on a circuit different from that to which the receiver is connected.
- Consult the dealer or an experienced radio/TV technician for help.

CAUTION: Use shielded cables to connect this device to computers.

Any changes or modifications not expressly approved by the grantee of this device could void the user's authority to operate the equipment.

ETAT DE CONFORMITE EMI A L'USAGE DES UTILISATEURS CANADIENS

Cet équipement produit et utilise l'énergie à radiofréquences et s'il n'est pas installé et utilisé correctement, c'est à dire en accord strict avec les instructions du fabricant, il y a un risque de provoquer des interférences avec la réception de la radio et de la télévision.

Le présent appareil numérique n'émet pas de bruits radioélectriques dépassant les limites applicables aux appareils numériques de la classe A prescrites dans le Règlement sur le brouillage radioélectrique édicté par le ministère des Communications du Canada.

Cet équipement est conçu pour fournir une protection satisfaisante contre de telles interférences dans une installation résidentielle. Cependant, il n'y a pas de garantie contre les interférences avec les réceptions radio ou télévision, provoquées par la mise en et hors circuit de l'équipement; aussi, il est demandé à l'utilisateur d'essayer de corriger l'interférence par l'une ou plus des mesures suivantes:

- Réorienter l'antenne de réception.
- Installer l'ordinateur autre part, par égard pour le récepteur.
- Brancher l'ordinateur dans une prise de courant différente de façon à ce que l'ordinateur et le récepteur soient branchés sur des circuits différents.

Important Safety Instructions

1. Read all of these instructions and save them for later reference.
2. Follow all warnings and instructions marked on the product.
3. Unplug this product from the wall outlet before cleaning. Do not use liquid or aerosol cleaners. Use a damp cloth for cleaning.
4. Do not use this product near water.
5. Do not place this product on an unstable cart, stand or table. The product may fall, causing serious damage to the product.
6. Slots and openings on the cabinet and the back or bottom are provided for ventilation.
To ensure reliable operation of the product and to protect it from overheating, do not block or cover these openings. The openings should never be blocked by placing the product on a bed, sofa, rug or other similar surface. This product should never be placed near or over a radiator or heat register. This product should not be placed in a built-in installation unless proper ventilation is provided.
7. This product should be operated from the type of power source indicated on the marking label. If you are not sure of the type of power available, consult your dealer or local power company.
8. This product is equipped with a three-pronged plug, a plug having a third (grounding) pin. This plug will only fit into a grounding-type power outlet. This is a safety feature. If you are unable to insert the plug into the outlet, contact your electrician to replace your obsolete outlet. Do not defeat the safety purpose of the grounding-type plug.
9. Do not allow anything to rest on the power cord. Do not locate this product where the cord will be walked on.
10. If an extension cord is used with this product, make sure that the total of the ampere ratings on the products plugged into the extension cord do not exceed the extension cord ampere rating. Also, make sure that the total of all products plugged into the wall outlet does not exceed 15 amperes for 120V outlet and 7.5 amperes for 220V–240V outlet.
11. Never push objects of any kind into this product through cabinet slots as they may touch dangerous voltage points or short out parts that could result in a risk of fire or electric shock. Never spill liquid of any kind on the product.
12. Except as explained elsewhere in this manual, don't attempt to service this product yourself. Opening and removing those covers that are marked "Do Not Remove" may expose you to dangerous voltage points or other risks. Refer all servicing on those compartments to service personnel.
13. The mains plug on this equipment must be used to disconnect mains power. Please ensure that the socket outlet is installed near the equipment and shall be easily accessible.
14. Unplug this product from the wall outlet and refer servicing to qualified service personnel under the following conditions:
 - A. When the power cord or plug is damaged or frayed.
 - B. If liquid has been spilled into the product.
 - C. If the product has been exposed to rain or water.
 - D. If the product does not operate normally when the operating instructions are followed. Adjust only those controls that are covered by the operating instructions since improper adjustment of other controls may result in damage and will often require extensive work by a qualified technician to restore the product to normal operation.
 - E. If the product has been dropped or the cabinet has been damaged.
 - F. If the product exhibits a distinct change in performance, indicating a need for service.

Notice

1. Before use, be sure to read this manual. And keep it handy for reference when needed.
2. The contents of this manual may change without prior notice.
3. Reproduction, transfer, or transmission of the contents of this manual without prior consent is strictly prohibited.
4. We are not liable for any damage resulting from the use of the information contained herein, regardless of errors, omissions, or misprints.
5. We are not liable for any problems resulting from the use of optional products and consumable supplies other than the designated products contained herein.
6. Do not handle, disassemble or repair the parts other than those specified in this manual.
7. We are not liable for any damage caused by user's erroneous use of the printer and inadequate environment.
8. Data residing in the printer is temporary. Therefore, all data will be lost if power is lost. We are not liable for any damage or loss of profits caused by data loss due to failures, repairs, inspections, etc.
9. Please contact us if there are any mistakes or ambiguities within this manual.
10. If there are missing or incorrectly collated pages in this manual, contact us to obtain a new manual.

SAFETY INSTRUCTIONS

— must be strictly observed !

To prevent personal injury or property damage, the following shall be strictly observed.

The degree of possible injury and damage due to incorrect use or improperly following instructions is described below.



WARNING

Indicates a situation which, if not observed and handled properly, could result in death or serious injury.



CAUTION

Indicates a situation which, if not observed and handled properly, could result in injury.



This is a mark to call attention to the reader.



WARNING

- Never perform the following. If not avoided, these may cause damage or trouble to the printer or cause the printer to overheat and release smoke and cause burns or an electrical shock. If the printer is damaged or is malfunctioning, be sure to turn the power off immediately and remove the power cord from the outlet, then consult our service personnel.
 - Do not jolt or impact to the printer by stepping on, dropping or hitting the printer.
 - Do not place the printer in a poorly ventilated area, or shut off the air vent of the printer.
 - Do not place the printer where chemical reactions occur, such as in laboratories or where air is mixed with salt or gas.
 - Do not use a power voltage or frequency other than those specified.
 - Do not plug/unplug the power cord or attach/detach the interface cable by simply grabbing the power cord or interface cable. Do not pull or carry the printer when the tension of the power cord or interface cable is increased.
 - Do not drop or put foreign matter such as clips and pins into the printer. This may cause problems.
 - Do not plug the power cord into an outlet with many loads.
 - Do not spill drinks such as tea, coffee and juice on the printer or spray insecticide on the printer. If drink or water is spilled, first be sure to turn the power off and remove the power cord from the outlet, then consult our service personnel.
 - Do not disassemble or modify the printer.

- Discard or safely store the plastic packing bag. This bag should be kept away from children. If the bag is pulled over a child's head, it may cause suffocation.

General Precautions

1. Prior to operation, read the safety instructions carefully and observe them.
2. Do not drop or put foreign matter such as clips and pins into the printer. This may cause problems.
3. Be careful when moving or carrying the printer. Dropping the printer may cause injury or property damage.
4. Make sure if you open the top cover, it is opened all the way. If only partially open, the cover could slam shut, possibly causing injury.
5. When the cover is open, be careful of the corners of the cover. They could cause injury.
6. Do not open the printer during printing.
7. When cleaning the surface of the printer case, do not use the cloth that is soaked in thinner, trichloroethylene, benzene, ketone or similar chemicals.
8. Do not use the printer where there is a lot of oil, iron particles, or dust.
9. Do not spill liquids or spray insecticide on the printer.
10. Do not jolt or impact to the printer by stepping on, dropping or hitting the printer.
11. Operate the control panel properly. A careless, rough handling may cause problems or malfunction. Do not use such sharp-edged tool as a ballpoint pen for operation.
12. Be careful of the edges of the plates so injury or property damage is possible.
13. If a problem occurs during printing, stop the printer immediately and unplug the power cord from the outlet.
14. When printer trouble occurs, do not try to disassemble it. Instead, consult our service personnel.

Precautions When Installing the Printer

1. Prior to operation, read the safety instructions carefully and observe them.
2. Do not use or store the printer near fire, excessive moisture, in direct sunlight, near an air conditioner or heater or other source of unusually high or low temperature or humidity or excessive dust.
3. Do not place the printer where chemical reactions occur, such as in a laboratory.
4. Do not place the printer where air is mixed with salt or gas.
5. The printer must sit on a firm, level surface where there is ample ventilation. Never allow the printer's air vent to be blocked by a wall or other object.
6. Do not put anything on the top of printer.
7. Do not place the printer near a radio or television, and do not use the same wall outlet for the printer and radio or television. Radio or television reception could be adversely affected.
8. Do not use a power voltage or frequency other than those specified.
9. Do not put anything on the power cord or step on it.
10. Do not drag or carry the printer with the power cord or interface cable.
11. Avoid plugging the power cord into an outlet with many loads.
12. Do not bundle the power cord when inserting the plug.
13. Always grip the plug housing, not the cord, to plug/unplug the power cord.
14. Make certain the power is turned off before connecting/disconnecting the interface cable.
15. Avoid lengthening the signal cable or connecting it to any noise-producing device. If it is unavoidable, use the shielded cable or twisted pair for each signal.
16. Place the printer near the outlet where the power cord can be unplugged easily to shut off power.
17. Use the AC outlet that accepts a three-pronged plug. Otherwise, static electricity may be generated and there will be danger of electric shock.

Contents

Before Operation

FCC COMPLIANCE STATEMENT FOR AMERICAN USERS	1
EMI COMPLIANCE STATEMENT FOR CANADIAN USERS	2
Important Safety	3
Notice	4
Safety Instructions.....	5
Warning.....	6
General Precautions.....	7
Precautions When Installing the Printer.....	8
Contents	9
Main Features	11
Model Description	12

Chapter 1 Setup

1 Confirmation of Carton Contents.....	14
2 Part Names and Functions.....	15
3 Connection to Power.....	18
4 Connection to a Computer.....	19

Chapter 2 Printer Operation

1 Power On/Off.....	21
2 Normal Operating Mode.....	23
3 Printer Setup Mode	24
4 Self-Test Mode.....	26
5 System Maintenance Mode.....	28
6 Returning to Factory Setting.....	31

Chapter 3 Paper and Ribbon

1	Kinds of Paper	34
2	Media Handling (When Using Front Sensors)	35
3	Media Handling (When Using Adjustable Sensor)	36
4	Paper Setting	37
5	Kinds of Ribbon.....	39
6	Ribbon Setting	40

Chapter 4 Printer Adjustments

1	Using Paper Other Than the Recommended (Head Offset Adjustments) 43	
2	Using Narrow Paper (Head Pressure Adjustments)..... 44	
3	Using Narrow Ribbon (Ribbon Tension Adjustments)..... 45	
4	Adjustable Sensor (For CLP-7001/7401)	46
5	Cleaning.....	47

Chapter 5 Troubleshooting

1	Error Messages	49
2	Power Troubleshooting.....	53
3	Paper Feed Troubleshooting	54
4	Ribbon Feed Troubleshooting.....	55
5	Print Troubleshooting	56
6	Interface Troubleshooting.....	57

Appendixes

1	Options	60
2	Specifications.....	62

Main Features

High-speed, high-quality printing

This printer adopts both a direct-thermal and thermal-transfer printing system with the line thermal head and its unique control IC enables high-speed and high-quality printing.

Precision printing for additional value: 400dpi

New technologies such as the newly-developed 400dpi head in the CLP-7401, unique control IC and optimized driving technology for high-resolution printing are all available on Citizen label printers creating labels that are crisp, clear, easy-to-read and scan. Also, thanks to the additional front (label) sensors, an amazingly high level of accuracy can be achieved; small sized labels, miniature bar codes and small fonts are produced on demand and in the correct position leading to a reduction in cost, lead time and stock holding.

Powerful control language

A powerful yet simple to use control language is standard to all of Citizen's label printers allowing easy design of labels and bar codes. Alternatively, Citizen provides printer drivers for popular operating systems such as Windows™.

Easy operation

Thanks to the clam-shell mechanism, labels, media and ribbons are loaded easily and maintenance such as head cleaning is carried out smoothly.

Parallel and serial ports as the standard

The parallel port (Centronics) in addition to the serial port is provided as the standard to enable high-speed data transmitting and industry compatible connectivity.

Adjustable media sensor

The moveable media detection sensor, standard on the CLP-7001 and CLP-7401 allows irregularly cut labels and tags to be used with ease. The sensors can also detect black registration marks that are not at the edge of the media.

Trademark Acknowledgement:

Windows: Microsoft Corporation

Model Description

This manual is prepared for the three models, CLP-7001, CLP-7002 and CLP-7401.
The main different points on the specifications among the three are shown below.

Model	Print resolution	Printing speed	Adjustable sensor
CLP-7001	203dpi	2-7 IPS	Standard
CLP-7002	203dpi	2-6 IPS	Optional
CLP-7401	400dpi	1-4 IPS	Standard

Chapter 1

Setup

- 1 Confirmation of Carton Contents
- 2 Part Names and Functions
- 3 Connection to Power
- 4 Connection to a Computer



1 Confirmation of Carton Contents

Check that the following accessories are included with the printer in the carton.

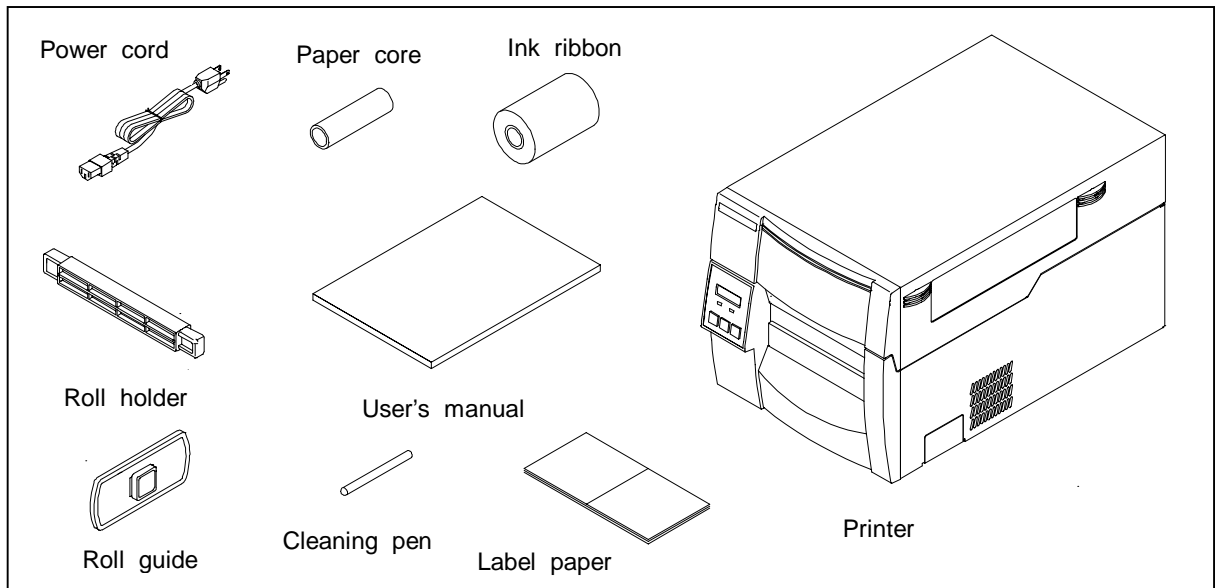

- The empty carton and packing materials should be stored for future shipping of the printer.

CAUTION

- Be careful when moving or carrying the printer and when taking the printer out of the carton. The printer may cause injury or property damage if dropped. Be sure to grip the printer housing tightly when taking it out of the carton. Do not grip the printer by the foam packing material which may break, causing the printer to drop.

2 Part Names and Functions

Front view

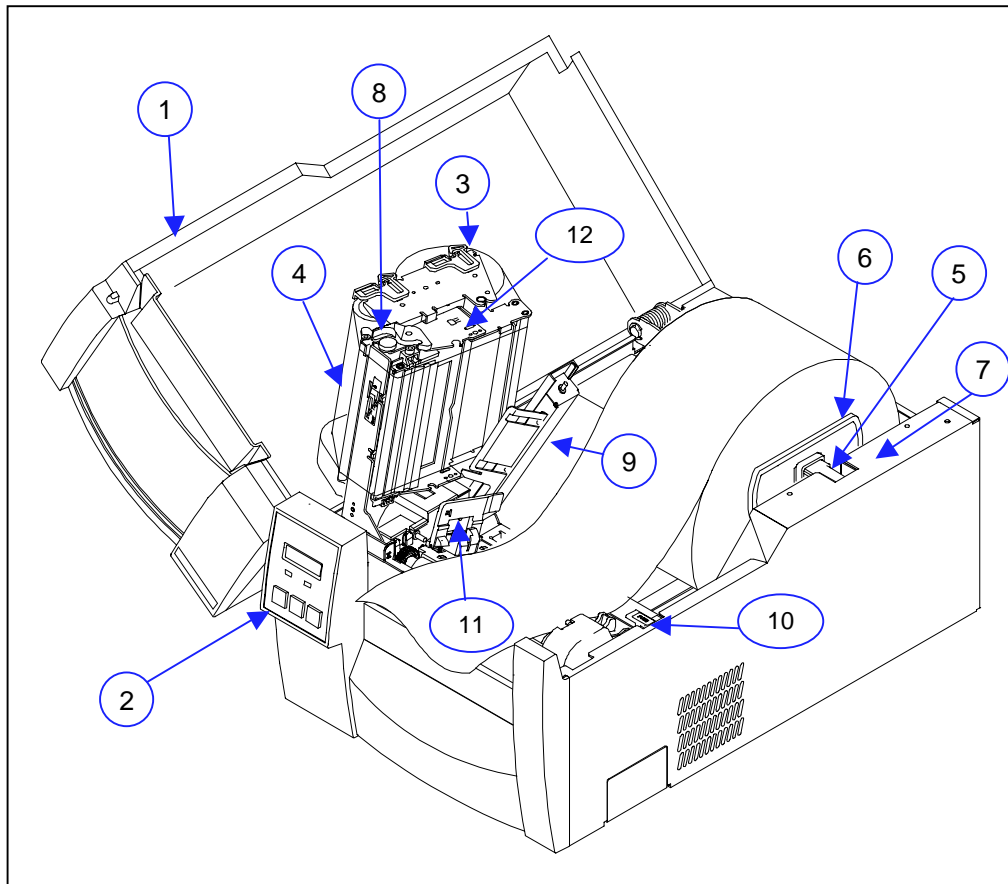

- | | |
|---|--|
| <p>1 Cover
Opens to allow loading of the paper and ribbon.</p> <p>2 Control panel
To set the printer settings. (See Chapter 2.)</p> <p>3 Ribbon holder
To attach the ribbon. (See Chapter 3.)</p> <p>4 Ribbon winder
To wind the ribbon after print. (See Chapter 3.)</p> <p>5 Roll holder
Holds the roll of paper.</p> <p>6 Roll guide
Guides the roll of paper. This is adjusted according to the width of the paper. (See Chapter 3.)</p> <p>7 Paper holder
Holds the roll holder. (See Chapter 3.)</p> | <p>8 Open lever
To swing the print head out of the way when loading the paper or cleaning the print head. (See Chapter 3.)</p> <p>9 Open guide
Holds down the paper. The movable sensor inside this (when the model is an adjustable sensor type) detects the paper position. (See Chapter 3.)</p> <p>10 Open guide lever
Pressing this opens the open guide to replace the paper. (See Chapter 3.)</p> <p>11 Front sensors
Detect the label and tag paper position. (See Chapter 3.)</p> <p>12 Offset verification window
Allows you to check the optimum position of the print head. (See Chapter 4.)</p> |
|---|--|

2 Part Names and Functions

Rear view

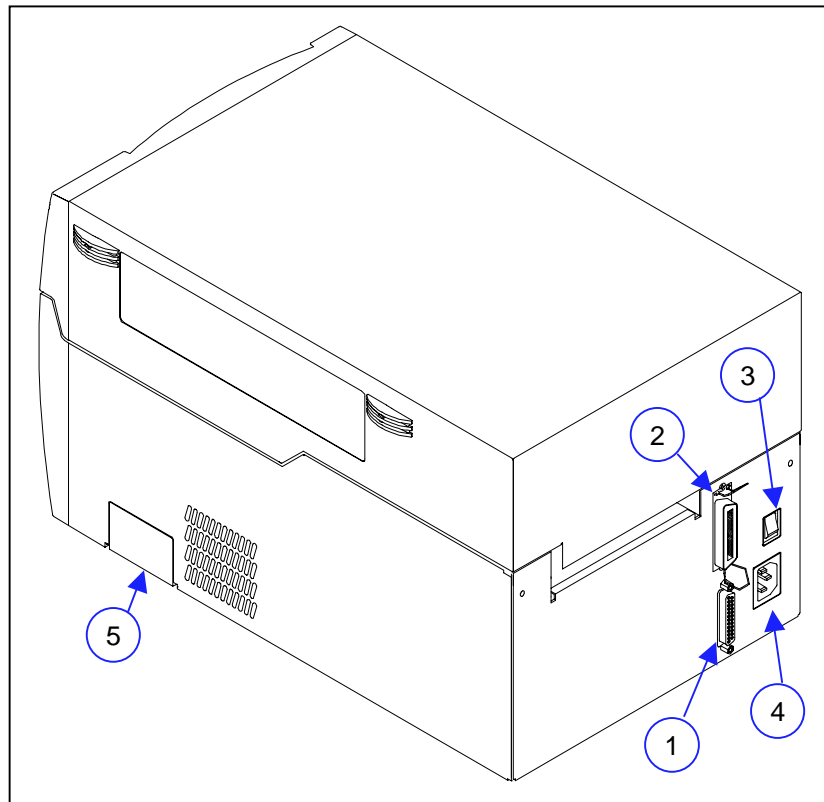

- 1 Serial interface connector**
To connect the serial interface cable.
- 2 Parallel interface connector**
To connect the parallel interface cable.
- 3 Power switch**
To turn on or off the power. (See Chapter 2.)

- 4 Power inlet**
To connect the power cord.
- 5 PCMCIA memory card cover**
To protect the PCMCIA memory card from exposure to dust and foreign matter. To install a PCMCIA memory card, first unhook this cover, then slide it out. (See Appendixes.)

CAUTION

- When opening the cover, open it all the way. If only part way open, the cover could slam shut, possibly causing injury.
- Be careful of the edge of the cover when the cover is opened. It may cause injury or property damage.
- Be careful of the edges of the plates so injury or property damage is possible.

2 Part Names and Functions

Control panel

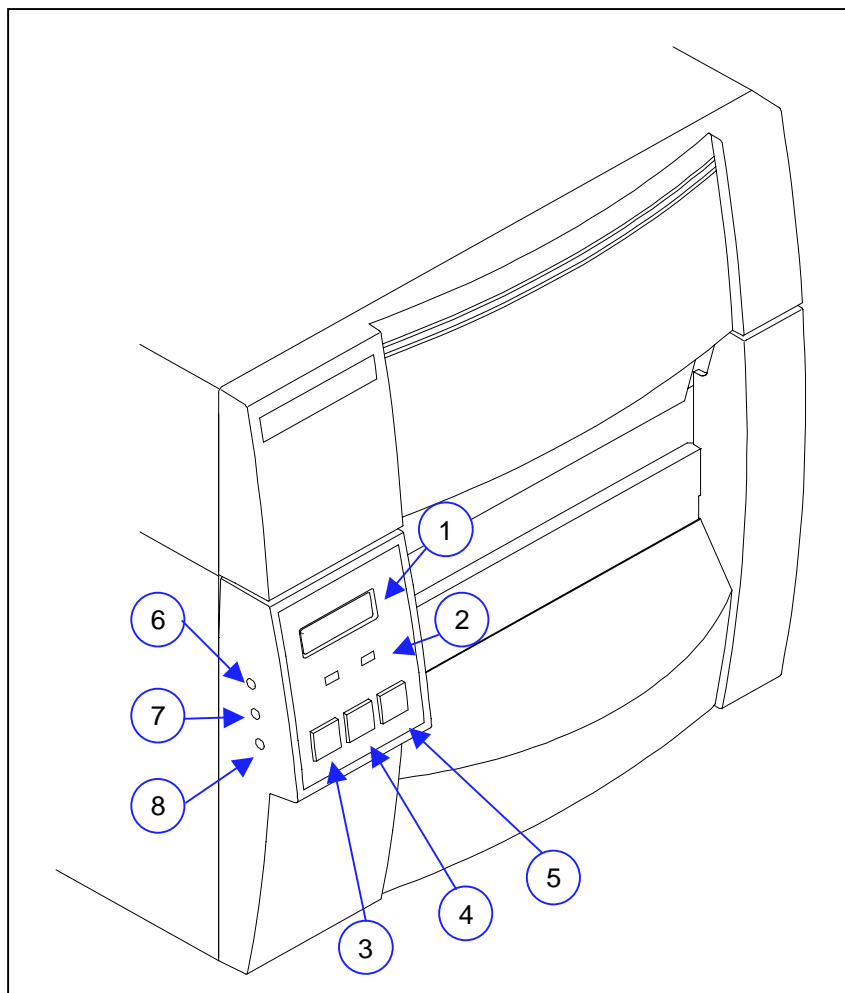

- | | |
|--|---|
| <p>1 LCD
Displays the current printer status, configuration settings, or an error message.</p> <p>2 LEDs
One LED is the power indicator and the other is the error indicator.</p> <p>3 Pause key
Temporarily pauses printing.</p> <p>4 Feed key
Feeds the paper.</p> | <p>5 Stop key
Stops the printer operating.</p> <p>6 Paper gap adjustment control
To adjust the paper gap sensor sensitivity.</p> <p>7 Black line adjustment control
To adjust the black line sensor sensitivity.</p> <p>8 LCD contrast adjustment control
To adjust the LCD contrast.</p> |
|--|---|

3 Connection to Power

1. Check that the power switch on the printer is turned OFF.
2. Connect the connector of the power cord to the power inlet on the printer.
3. Insert the plug of the power cord in the AC outlet.

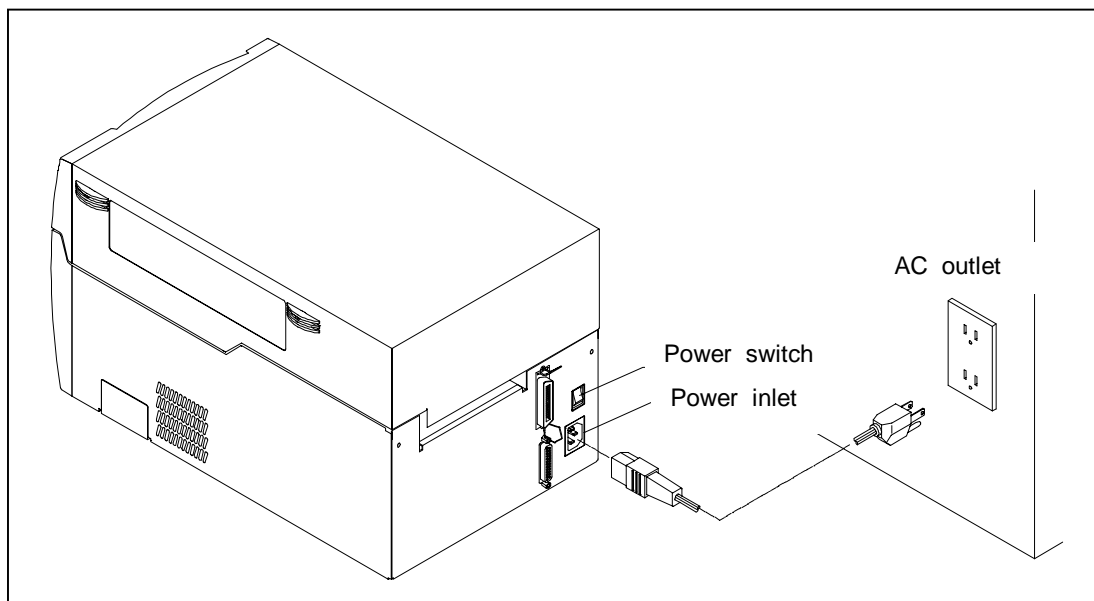

CAUTION

- Use an AC outlet that accepts a three-pronged plug. Otherwise, static electricity may be generated and there will be danger of electric shock.

4 Connection to a Computer

An interface cable is necessary to connect the printer to a computer. To connect the cable, proceed as follows.

1. Turn off both power switches of the printer and the computer.
2. Connect the connector of one end of the interface cable to the interface connector at the lower side of the printer and secure it with screws.
3. Connect the connector of the other end of the interface cable to the interface connector on the computer and secure it with screws.

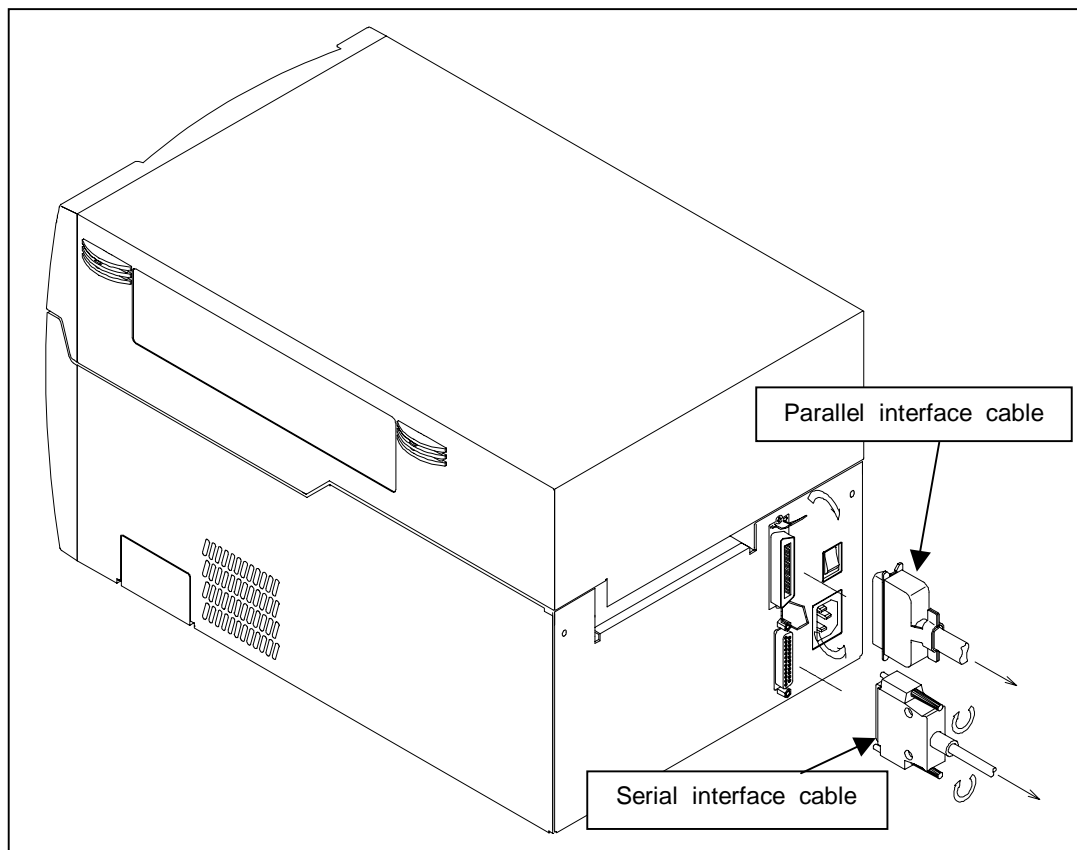

Chapter 2

Printer Operation

- 1 Power On/Off
- 2 Normal Operating Mode
- 3 Printer Setup Mode
- 4 Self-Test Mode
- 5 System Maintenance Mode
- 6 Returning to Factory Setting



1 Power On/Off

Turning on the power

1. Turn on the power switch on the back of the printer.

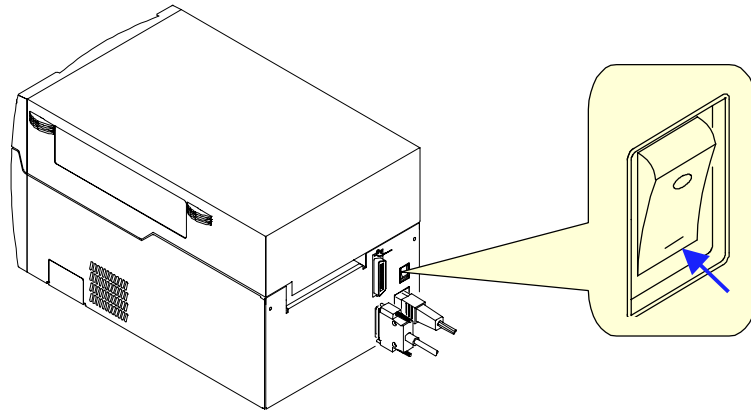

2. The green LED power indicator goes on. Check that the LCD screen displays 'ON LINE.'

When operating normally

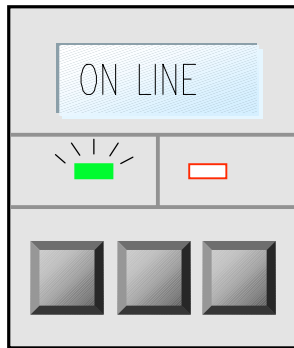

When displaying an error message

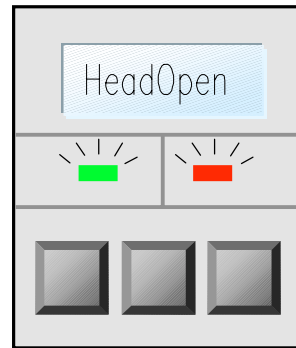

When displaying no message

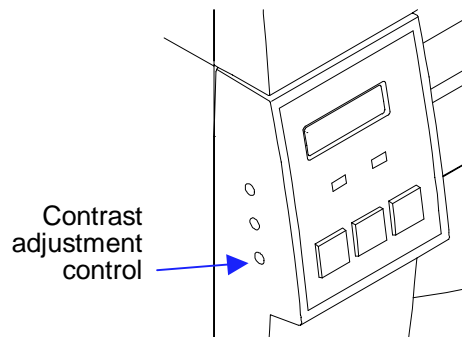
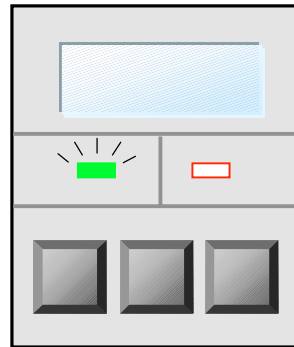

Turn the LCD contrast adjustment control with a small Phillips head screwdriver.

1 Power On/Off

Turning off the power

1. Turn off the power switch on the back of the printer.

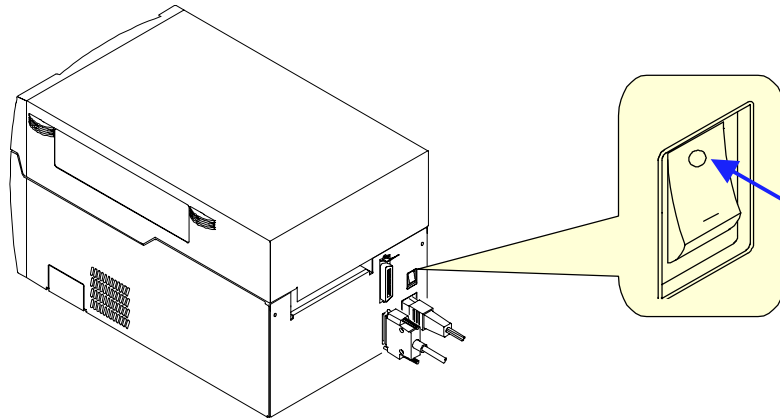

2. The green LED power indicator goes off and any message on the LCD screen disappears.

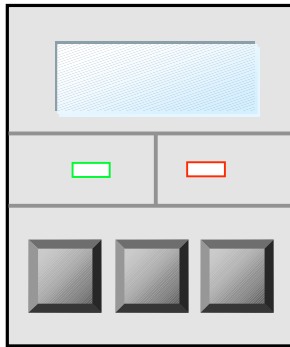

2 Normal Operating Mode

When the power is turned on, the printer enters normal operating mode. The control keys function as follows:

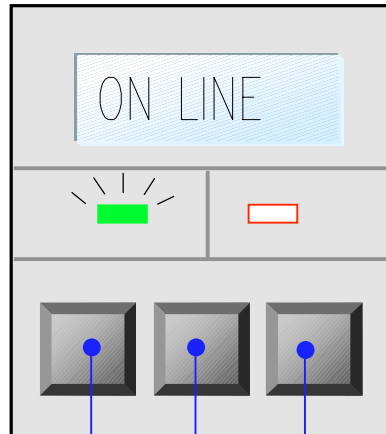

Stop key (STOP)

With this key, the operator can stop and cancel the current print job. Pressing the Stop key during printing stops the printing immediately. Pressing the Stop key again cancels the print job.

Feed key (FEED)

Advance to the top of the next label. When using continuous paper, make sure the Sensor selection is set to ContinuP or a Paper error will result.

Pause key (PAUSE)

Temporarily pauses printing. 'Pause' is displayed on the LCD screen. If pressed during printing, printing will stop after the current label is printed. Press the Pause key again to resume printing.

3 Printer Setup Mode

In this mode, the print mode, optional equipment ON/OFF and sensor selections are set up. Control keys function in the following. The printer configuration settings are stored in memory so they are maintained even after the power is turned off.

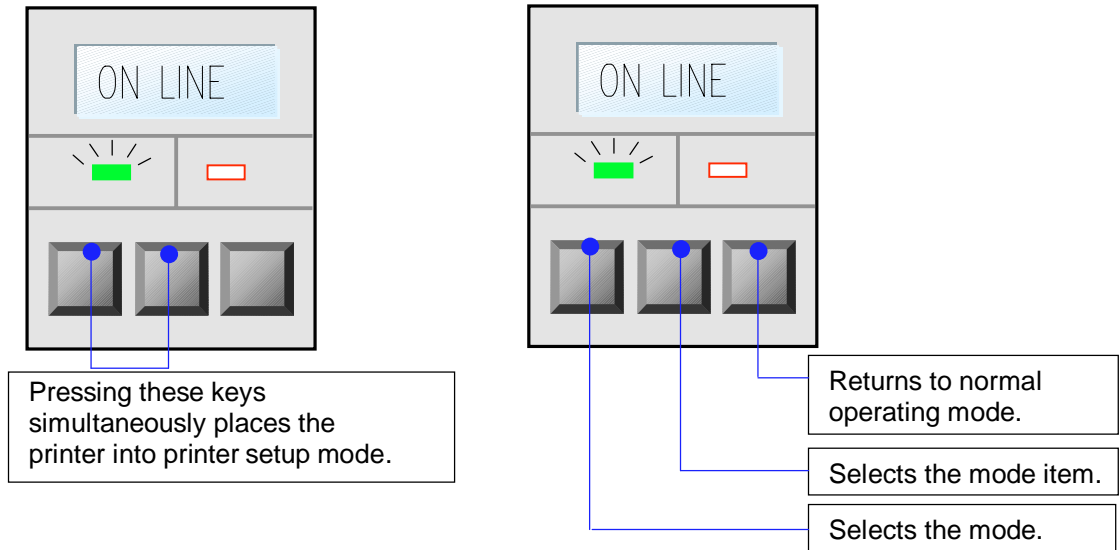

Example Changing the paper gap sensor to the black line sensor

1. First check the printer goes ON LINE, then press and hold the Pause key and then press the Feed key and release both keys.

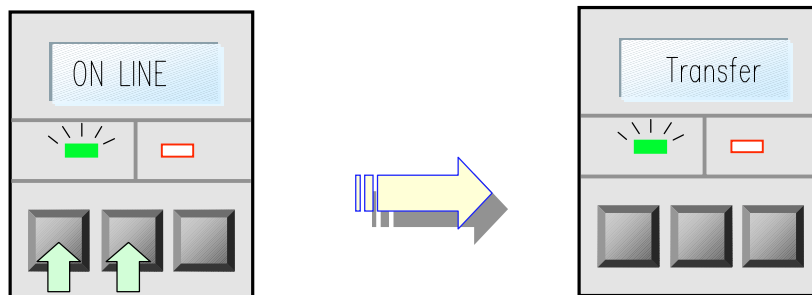

2. Change the print mode (direct-thermal or thermal transfer printing) to the sensor selection with the Pause key.

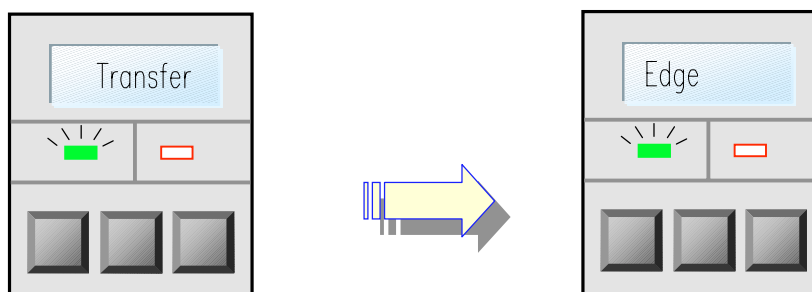



3 Printer Setup Mode

3. Change the paper gap sensor to the black line sensor with the Feed key.

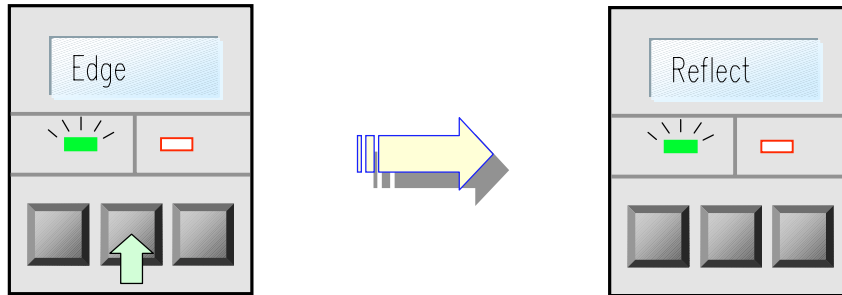

4. Return to normal operating mode with the Stop key.

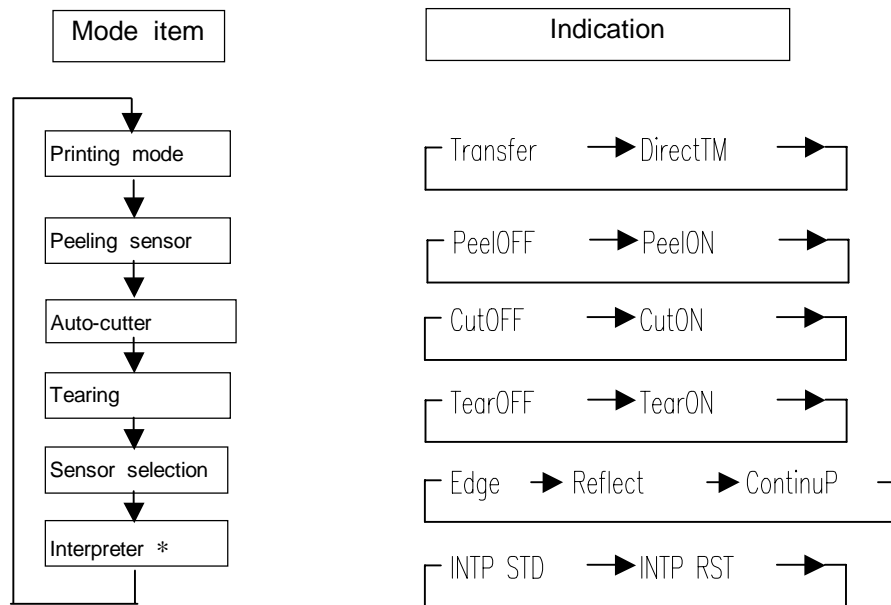
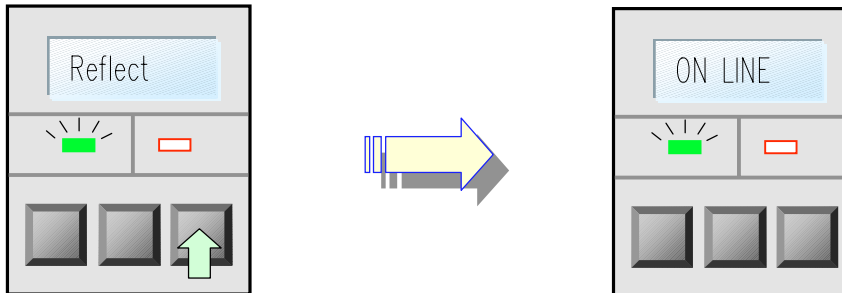

* Normally 'INTP STD' (interpreter standard) is used. See the Command Reference for details.

4 Self-Test Mode

In this mode, self-test printing is performed. With this test printing, you can check the current printer configuration settings and print quality. After loading the paper and ribbon, operate the printer as follows:

1. Press and hold the Feed key while turning the printer on.
 - When label paper is used: Hold down the Feed key for two (2) seconds and the printer will feed the paper and print samples 1 and 2 and stop.
 - When continuous paper is used: Hold down the Feed key for four (4) seconds and the printer will feed the paper and print samples 1 and 2 and stop.

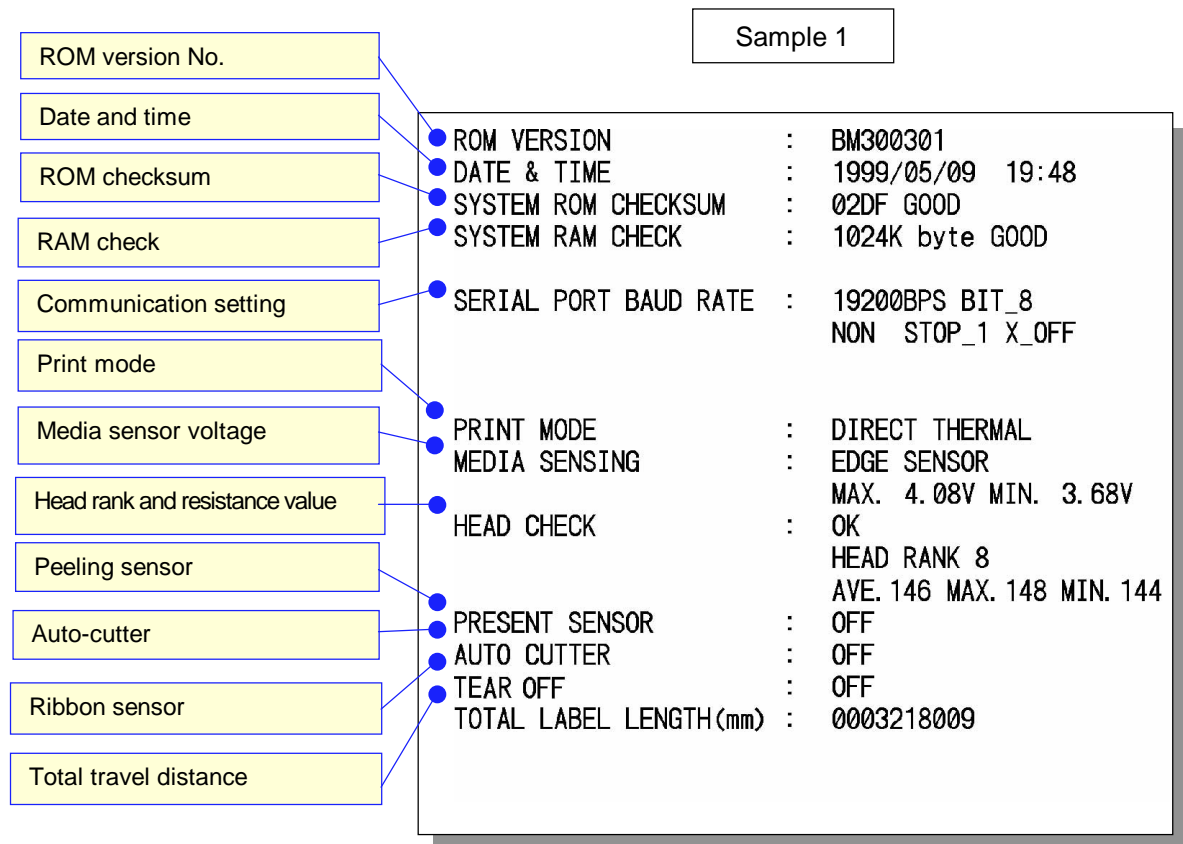
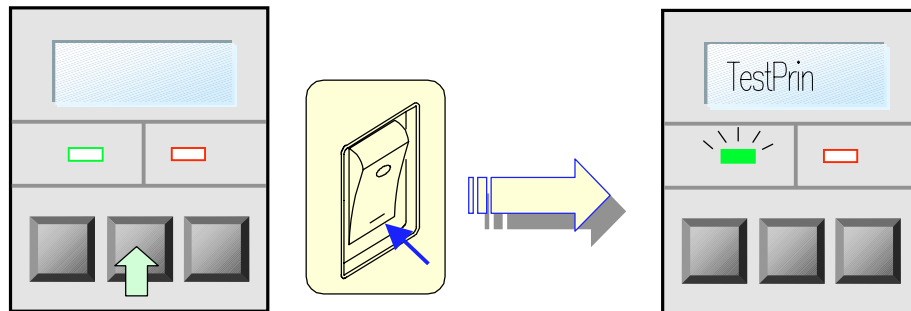

4 Self-Test Mode

Check the following items in the self-test mode.

Check item	Cause	Remedy
Dot missing	Head disconnected	Replace head
	Dust adhered	Clean head(→Section 5 Chapter 4)
Totally blurred	Head offset changed in position	Adjust head offset (→Section 1 Chapter 4)
	Printing energy low	Adjust printing energy (→Command Reference)
Partially blurred	Head pressure unbalanced	Adjust head pressure (→Section 2 Chapter 4)
Ribbon wrinkling and slipping	Ribbon tension improper	Adjust ribbon tension (→Section 3 Chapter 4)

Sample 2
203 dpi

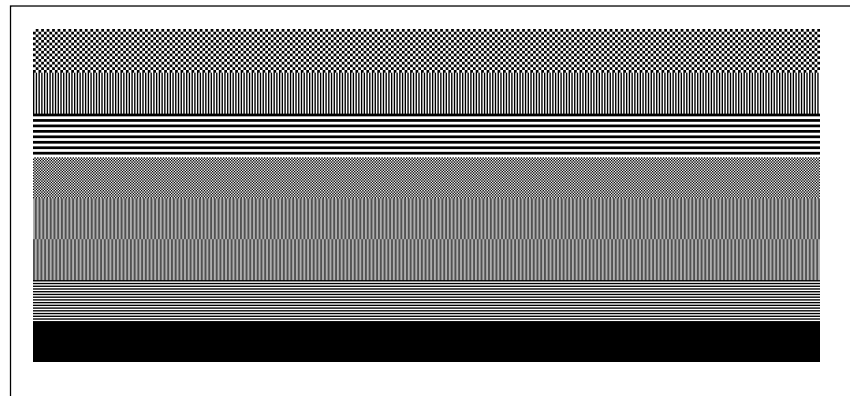

Sample 2
400 dpi

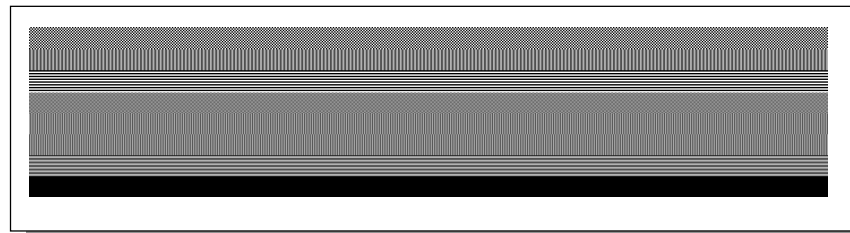

- After self-test printing, the printer enters data dump mode. The communication contents can be checked by printing the communication data in ASCII code.

DUMP LIST

```

024C4431310D4831300D313131313030      . LD11. H10. 111100
30303030303030303031323334353637      0000000001234567
38390D31313131303030303032303030      89. 1111000002000
30303132333435363738390D31343131      00123456789. 1411
30303030303030303032304142434445      00000000020ABCDE
464748494A4B4C4D4E4F505152535455      FGHIJKLMN0PQRSTU
0D45                                     . E

```

- Return to normal operating mode after turning off the power switch.

5 System Maintenance Mode

In this mode, the communication, adjustable sensor ON/OFF and sensor voltage selections are set up. The printer configuration settings are stored in memory so they are maintained even after the power is turned off. Control keys function as follows:

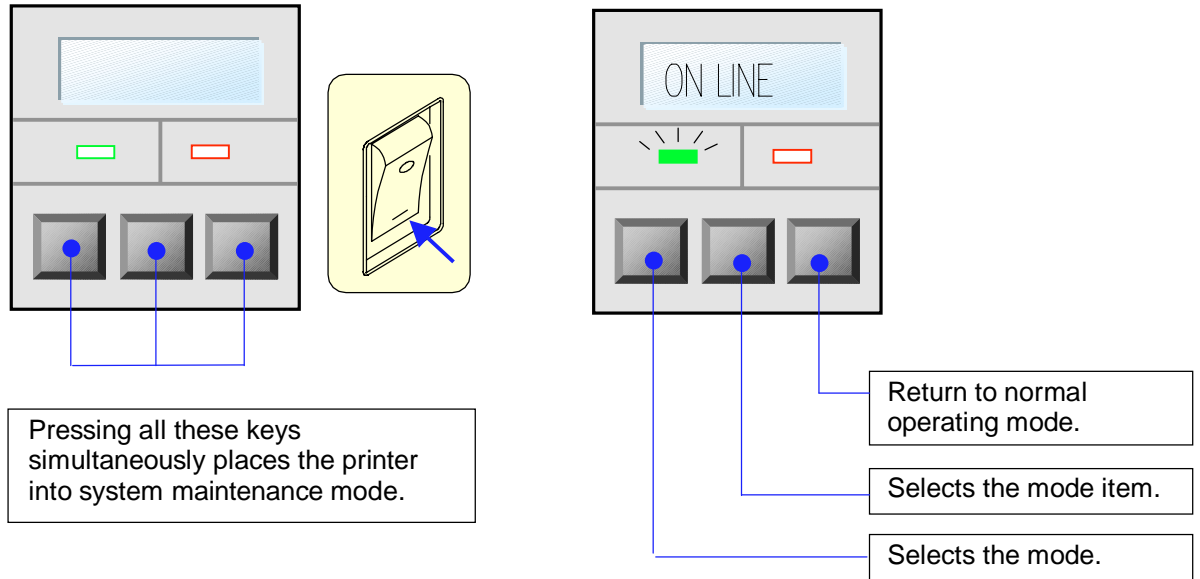

Example Setting the black line sensor voltage

1. First turn off the power switch, then press and hold down the Pause, Feed and Stop keys simultaneously while turning on the power switch.

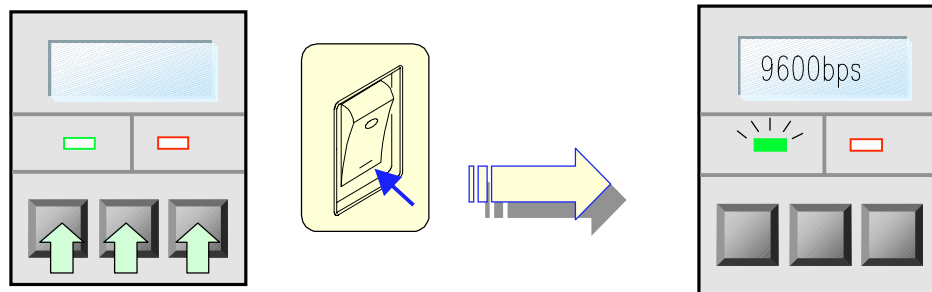

2. Change the baud rate to the sensor voltage setting with the Pause key.

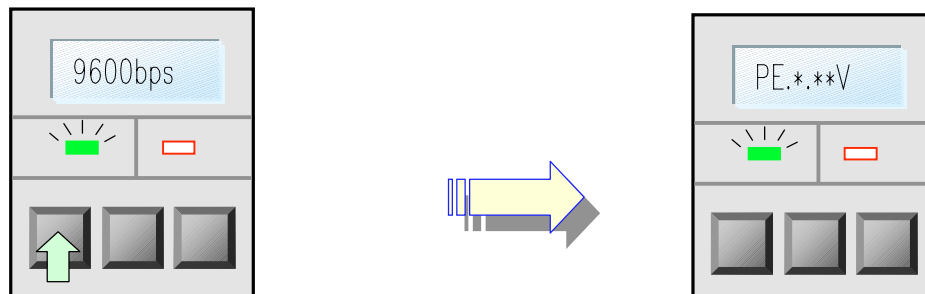

5 System Maintenance Mode

3. Change the paper gap sensor voltage to the black line sensor voltage with the Feed key.

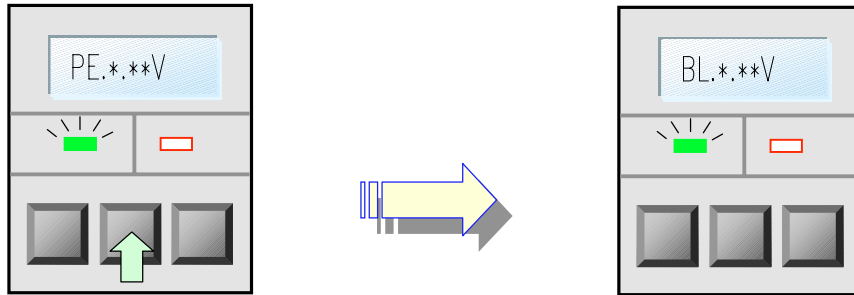

4. Return to normal operating mode with the St op key.

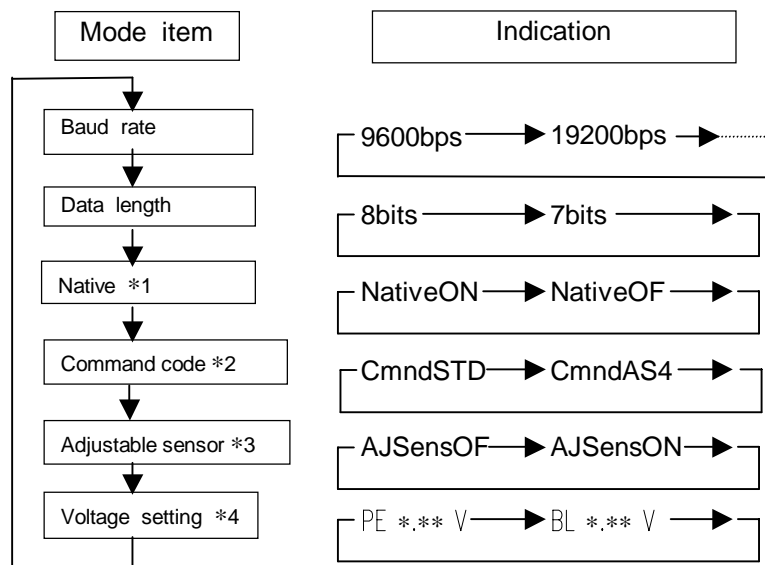
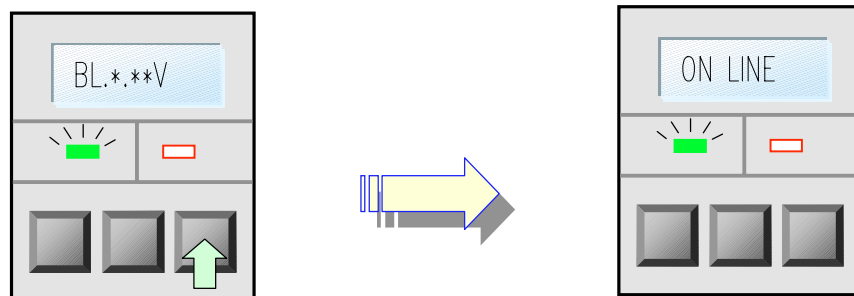

5 System Maintenance Mode

- *1 Native
Normally 'NativeON' is used. See the Command Reference for details.
- *2 Feed amount
See the Command Reference for details.
- *3 Command code
Normally 'CmndSTD' is used. See the Command Reference for details.
- *4 For adjustable sensor, the voltage setting must be done each time 'AJSensOF' is changed to 'AJSensON, and vice versa.
- *5 Voltage setting
In the voltage setting, adjust the paper gap and black line adjustment controls so that the voltages of both 'PE' and 'BL' displayed on the LCD screen can read 3.0V to 3.3V.
 1. Set the liner (glassine paper) only that has been removed from the label. (For the black line paper, position the black line so that it does not come to the paper sensor.)
 2. Set each level to 3.0V to 3.3V with the controls.

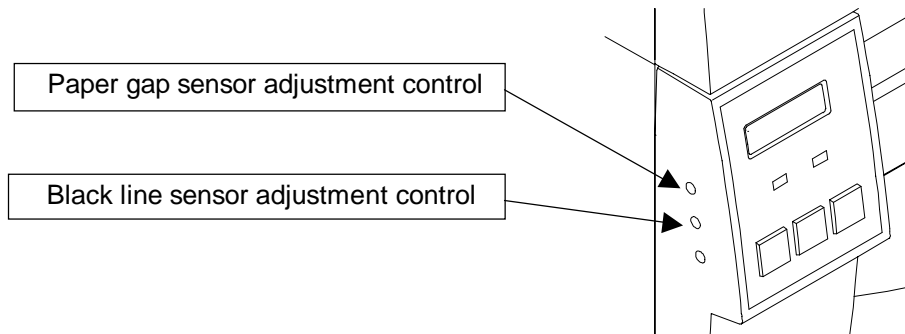

6 Returning to Factory Setting

To return the configuration already set in the printer setup mode or system maintenance mode to the factory setting, proceed as follows:

Turn off the power switch. Press and hold the Pause, Feed and Stop keys simultaneously while turning on the power switch, and further continue holding down those keys.

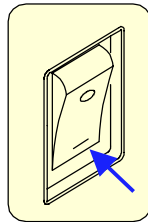
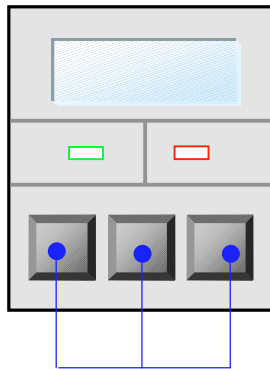

Press and hold those keys simultaneously while turning on the power switch

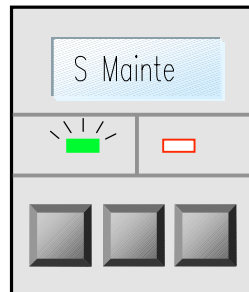

You hear a 'Pi' sound. Further continue holding down those keys

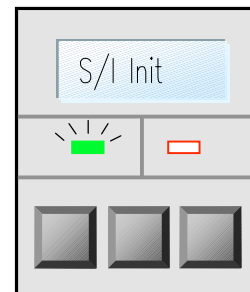
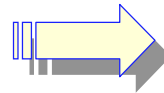

When you again hear a 'Pi' sound, the operation is completed

Factory setting

Printer setup mode		System maintenance mode	
Mode item	Indication	Mode item	Indication
Printing mode	Transfer	Baud rate	9600bps
Peeling sensor	PeelOFF	Data length	8bits
Auto-cutter	CutOFF	Native	NativeON
Tearing	TearOFF	Feed amount	fVirtual
Sensor selection	Edge	Command code	CmndSTD
Interpreter	INTP STD	Adjustable sensor	AJSensOF
—	—	Voltage setting	PE *.* V

Chapter 3

Paper and Ribbon

- 1 Kinds of Paper
- 2 Media Handling
(When Using Front Sensors)
- 3 Media Handling
(When Using Adjustable
Sensor)
- 4 Paper Setting
- 5 Kinds of Ribbon
- 6 Ribbon Setting

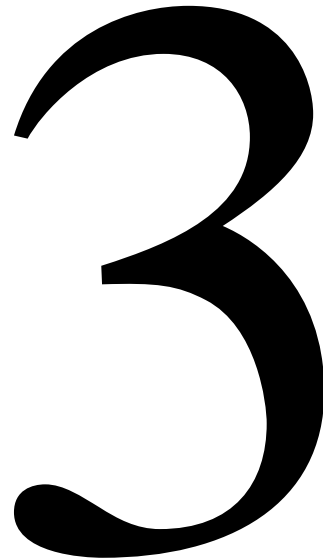

1 Kinds of Paper

	Item	Specification	
Kinds of paper	<ul style="list-style-type: none"> • Thermal-transfer paper • Direct-thermal paper 	<p>The printer is capable of printing on direct-thermal or thermal-transfer paper.</p> <p>The paper must be high-quality. Otherwise, good print quality and extended print head life cannot be guaranteed.</p>	
Type of paper	<ul style="list-style-type: none"> • Label paper (continuous, die-cut, fanfold) • Tag paper • Ticket 	Both in-wound and out-wound paper rolls may be used.	
Size of paper	Paper width	25.4–118 mm	1–4.65 in
	Paper thickness	0.0635–0.254 mm	0.0025–0.01 in
	Max. outer diameter of roll paper	203 mm	8 in
	Paper core inner diameter	38–76 mm	1.5–3 in

2 Media Handling (When Using Front Sensors)

The front sensors consist of the transparent-type and reflective-type photosensors and the position of a label or tag is detected as follows:

Transparent-type photosensor: Detects paper gap between labels and tag paper notch.

Reflective-type photosensor: Detects black line.

Note: Check that the adjustable sensor is set to 'AJSensOF.' (See Chapter 2.)

• Specification of paper

For dimensions of paper gap between labels, tag paper (label paper) notch and black line, see figure.

		Minimum value mm (in)	Maximum value mm (in)
A	Label width	7.62 (0.3)	118.00 (4.65)
B	Liner width	25.40 (1.0)	118.00 (4.65)
C	Label left edge position	0	2.54 (0.10)
D	Label paper gap length	2.54 (0.10)	2539.00 (99.96)
E	Label length	2.54 (0.10)	2539.00 (99.96)
F	Label pitch	5.08 (0.20)	2539.00 (99.96)
G	Liner thickness	0.06 (0.0025)	0.125 (0.0049)
H	Paper thickness	0.06 (0.0025)	0.25 (0.01)
I	Notch right end position	8.3 (0.32)	11 (0.43)
J	Notch left end position	0	4.7 (0.19)
K	Notch length	2.54 (0.10)	17.80 (0.70)
L	Black line right end position	15.00 (0.59)	–
M	Black line left end position	0	1.5 (0.06)
N	Black line width	3.18 (0.125)	17.80 (0.70)

- Note:
- Paper having both label paper gap and black line should use the paper -gap sensor.
 - Fanfold should use the paper-gap sensor.

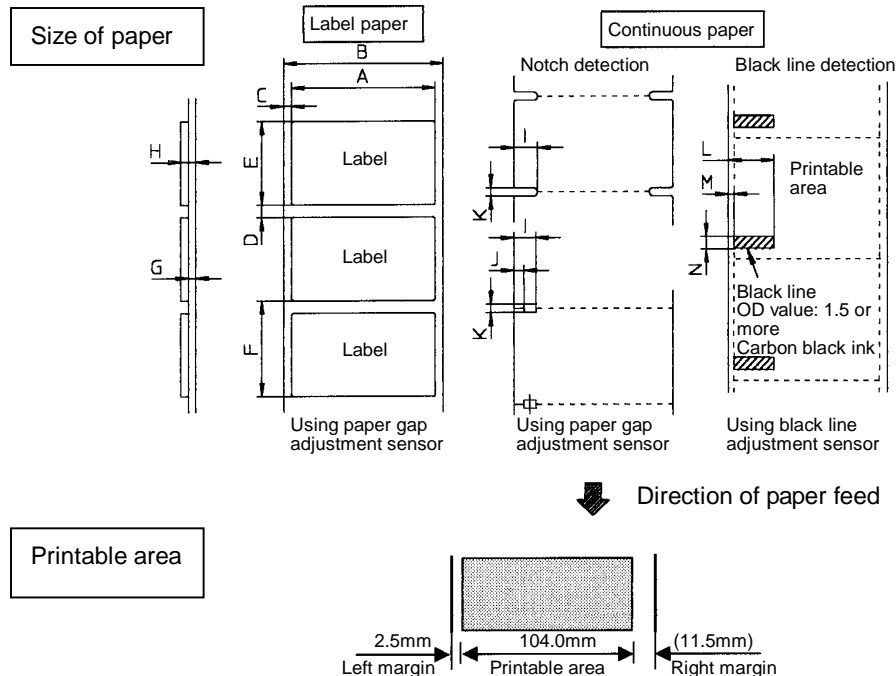

3 Media Handling (When Using Adjustable Sensor)

The adjustable sensor is the standard for CLP-7001 and CLP-7401 but it is the optional for CLP-7002.

Check that the adjustable sensor is set to 'AJSensON.' (See Chapter 2.)

		Minimum value mm (in)		Maximum value mm (in)	
A	Label width	25.40	(1.0)	118.00	(4.65)
B	Liner width	25.40	(1.0)	118.00	(4.65)
C	Label left edge position	0		2.54	(0.10)
D	Label paper gap length	2.54	(0.10)	2539.00	(99.96)
E	Label length	12.70	(0.50)	2539.00	(99.96)
F	Label pitch	12.70	(0.50)	2539.00	(99.96)
G	Liner thickness	0.06	(0.0025)	0.125	(0.0049)
H	Paper thickness	0.06	(0.0025)	0.25	(0.01)
I	Notch right end position	3.6	(0.14)	60.8	(2.39)
J	Notch left end position	0		57.2	(2.25)
K	Notch length	2.54	(0.10)	17.80	(0.70)
L	Black line right end position	15.00	(0.59)	66.5	(2.62)
M	Black line left end position	0		51.5	(2.02)
N	Black line width	3.18	(0.125)	17.80	(0.70)

- Note:
- Paper having both label paper gap and black line should use the paper-gap sensor.
 - Fanfold should use the paper-gap sensor.

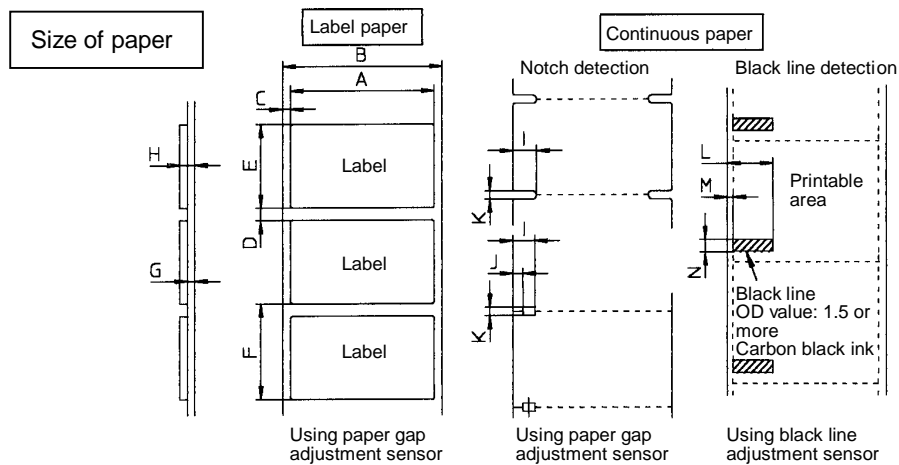

Direction of paper feed

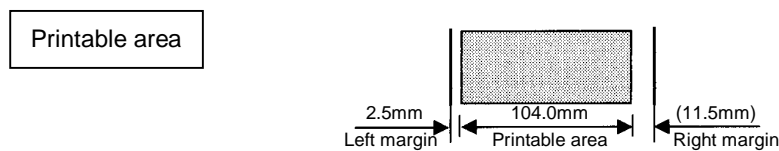

4 Paper Setting

The printer is designed for easy loading of paper. Open the printer cover and set the paper as follows:

1. Push down the open lever to open the print head.
2. Push down the open guide lever to lift the open guide up.

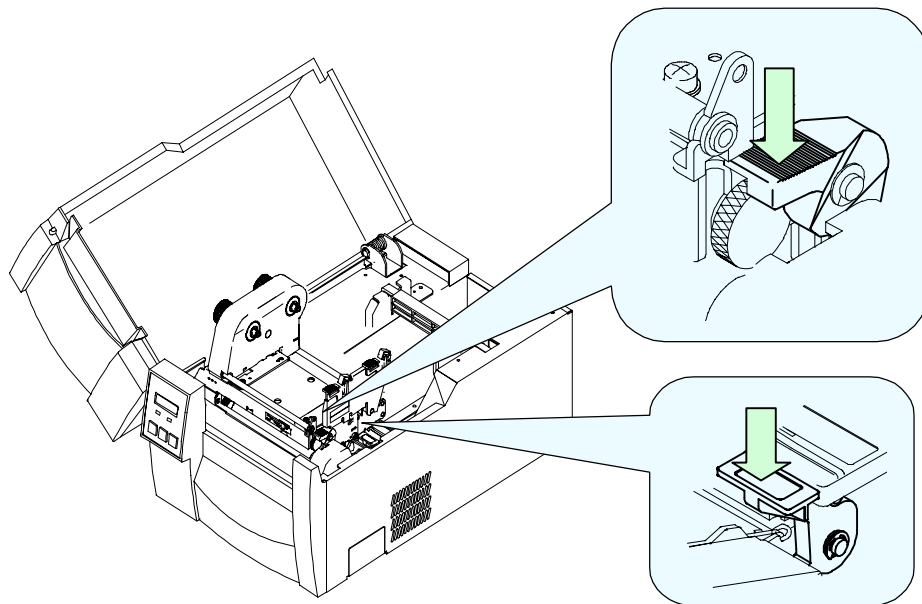

3. Attach the roll guide to the roll holder and insert this in the hole of the roll paper. Set the roll holder with the roll paper and guide on the paper holder and push this against the left-side wall so that the roll paper is positioned in its deepest position.

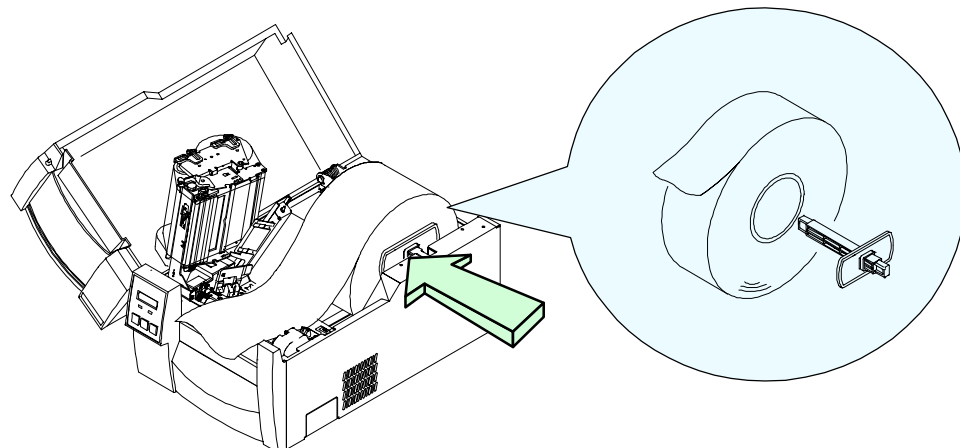

CAUTION

Be careful of the edges of the plates so injury or property damage is possible.

4 Paper Setting

4. ① Set the paper flush against the fixed paper guide on the left side.
- ② Guide the paper positively with the movable paper guide.
- ③ Align the paper top left edge with the notch of the tearing plate.

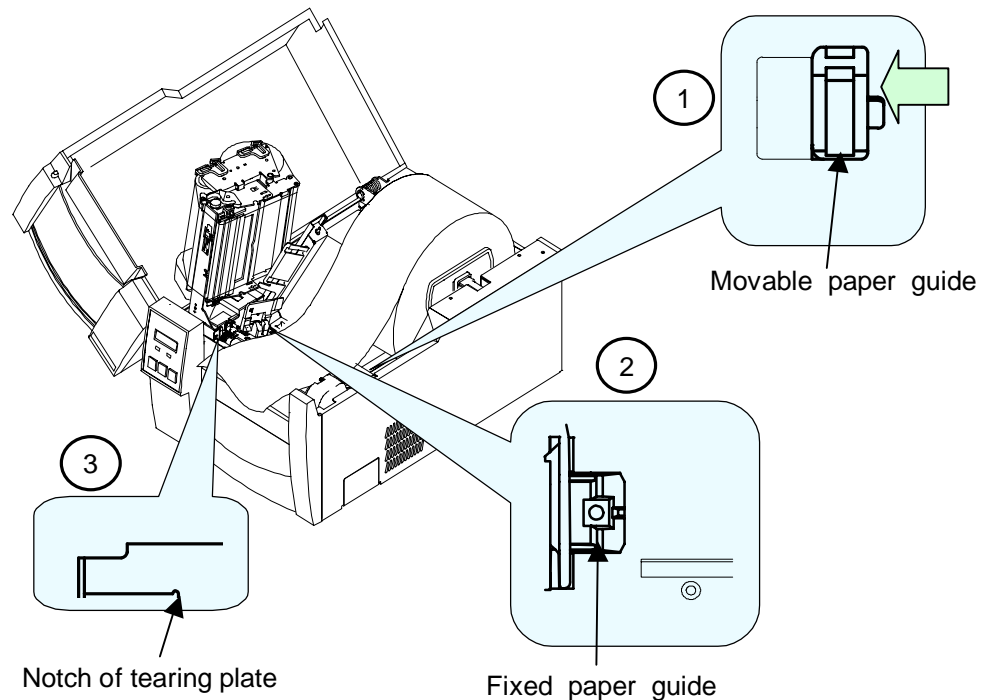

5. Slightly hold down the paper so as not to be skew and push down the open guide for closing.

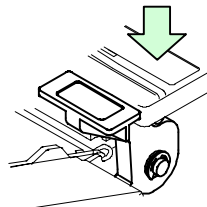

6. Push down the green tab on the front side until it clicks to securely close the printer mechanism.

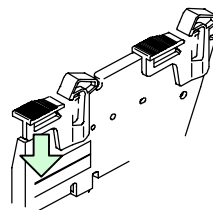

Note: Make certain the green part is pressed properly. Otherwise, the printer mechanism may fail to close.

7. Close the printer cover.
8. Turn on the power to the printer. The LCD screen on the control panel will display 'ON LINE.' Press the Feed key. The paper will advance to the next label and stop.

5 Kinds of Ribbon

	Item	Specification	
Kinds of ribbon	This printer uses a solid ink ribbon.		
	• Wax	Multipurpose ribbon.	
	• Wax resin	Multipurpose, high-quality ribbon.	
	• Resin	Special ribbon with weather resistance. When using this type, set the print speed slower and the printing energy greater.	
Type of ribbon	Both in-wound and out-wound ribbons can be used.		
Size of ribbon	With a single roll of ribbon (360 m), about two rolls of paper with outer diameter of 203 mm (8 in) can be used for printing.		
	• Ribbon width	25.4 – 114 mm	1 – 4.5 in
	• Recommended ribbon width: ±10% of width of paper used		
	• Max. length	360 m	1,181 feet
	• Max. outer diameter	74 mm	2.91 in
• Paper core inner diameter	25.4 ± 0.254 mm	1 ± 0.01 in	

6 Ribbon Setting

This printer is designed for easy loading of ribbon. Open the printer cover and set the ribbon as follows:

1. Push down the open lever to open the print head.

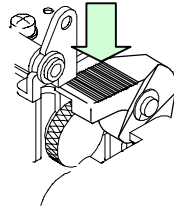

2. Insert the ribbon shaft in the hole of the ribbon until it is in its deepest position.
3. Set the ribbon holder on the transfer frame.

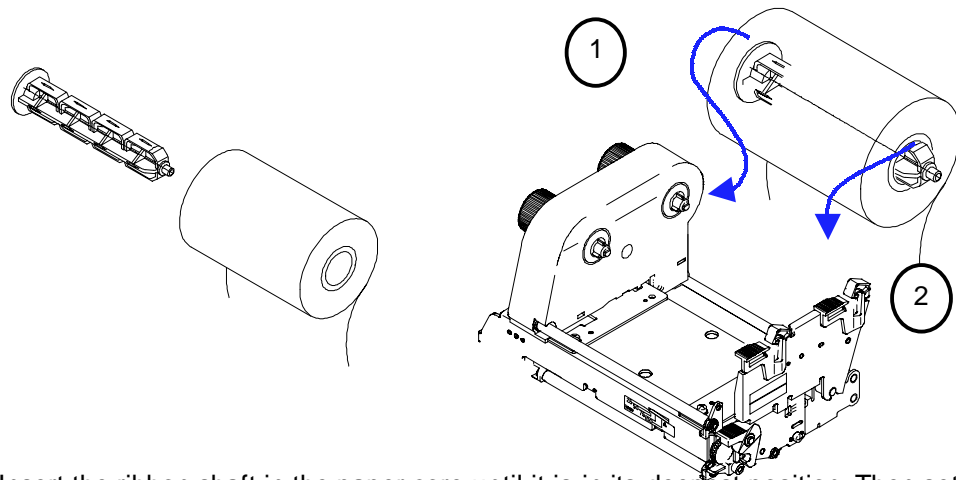

4. Insert the ribbon shaft in the paper core until it is in its deepest position. Then set this on the front side of the transfer frame.

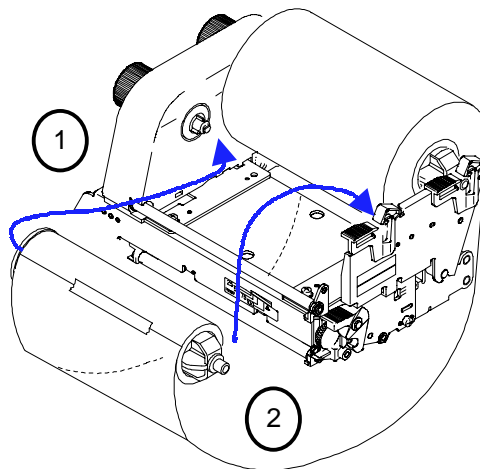

CAUTION

Be careful of the edges of the plates so injury or property damage is possible.

6 Ribbon Setting

5. Turn the knob on the front side in the direction of arrow to remove the slack of the ribbon.

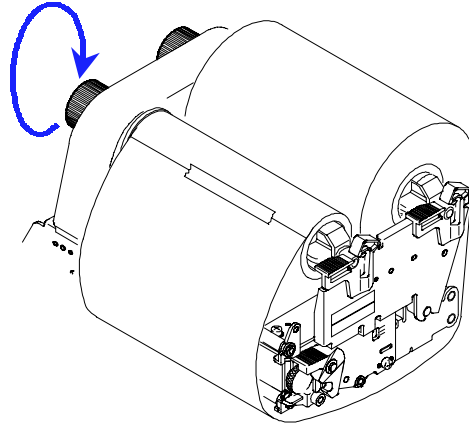

6. Push down the green part on the front side until it clicks to securely close the printer mechanism.

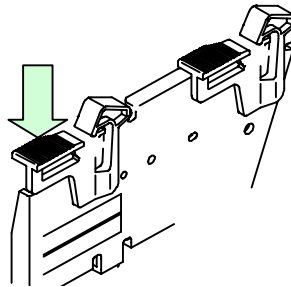

Note: Make certain the green part is pressed properly. Otherwise, the printer mechanism may fail to close.

7. Close the printer cover.
8. Turn on the power to the printer. The LCD screen on the control panel will display 'ON LINE.' Press the Feed key. The paper will advance to the next label and stop.

Chapter 4

Printer Adjustments

- 1 Using Paper Other Than the Recommended (Head Offset Adjustments)
- 2 Using Narrow Paper (Head Pressure Adjustments)
- 3 Using Narrow Ribbon (Ribbon Tension Adjustments)
- 4 Adjustable Sensor (For CLP-7001/7401)
- 5 Cleaning

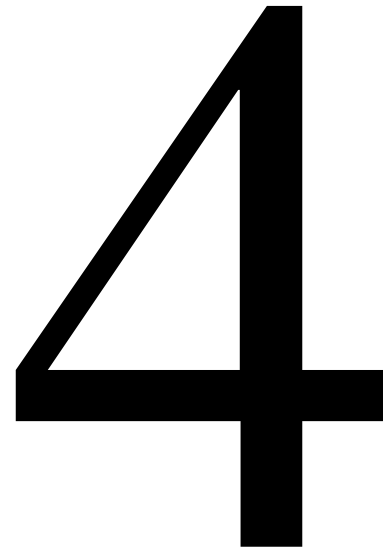

1 Using Paper Other Than the Recommended (Head Offset Adjustments)

The printer has already been factory-set to the proper print quality when using the recommended label paper. If the print quality is inferior because of the different type of paper, adjust the head offset as follows:

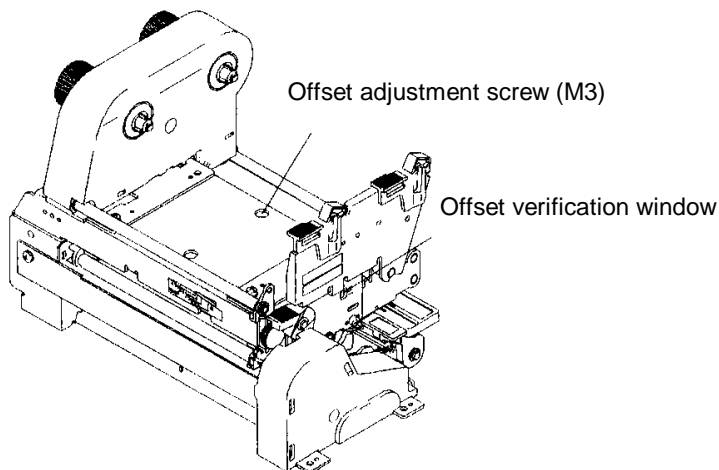

The relationship between the offset verification window and the print head heating element is shown below:

a) Print head position for label

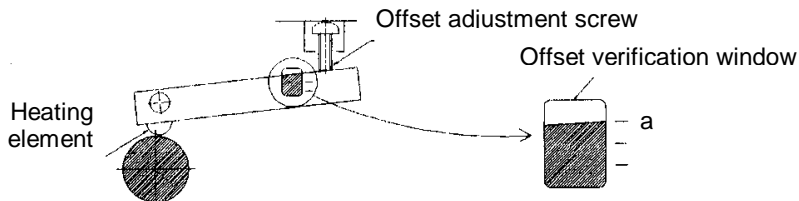

b) Print head position for tag

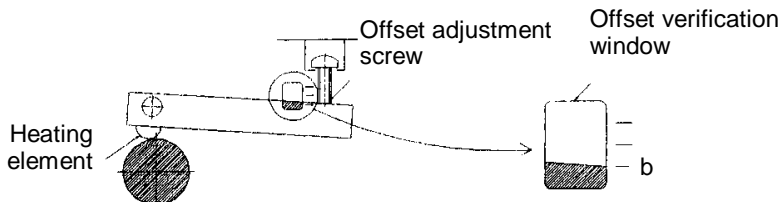

(a) When using standard label, slick, craft or thermal paper

- ① Peeping through the offset verification window, adjust the head offset so that it comes to the center line (middle of the three lines) by turning the offset adjustment screw with a screwdriver.

Turn the offset adjustment screw two or three turns counterclockwise with a screwdriver. (Factory set: Two turns.)

- ② Make fine adjustments, checking the self-test print.

(b) When using thick paper (tag or other paper)

- ① Peeping through the offset verification window, adjust the head offset so that it comes to the center line (middle of the three lines) by turning the offset adjustment screw with a screwdriver.

- ② Turn the offset adjustment screw two to four turns clockwise with a screwdriver.



- ③ Make fine adjustments, checking the self-test print.

2 Using Narrow Paper (Head Pressure Adjustments)

The printer has already been factory-set to the paper width of 112 mm (4.4 in). When you use narrow paper, adjust the head pressure as follows:

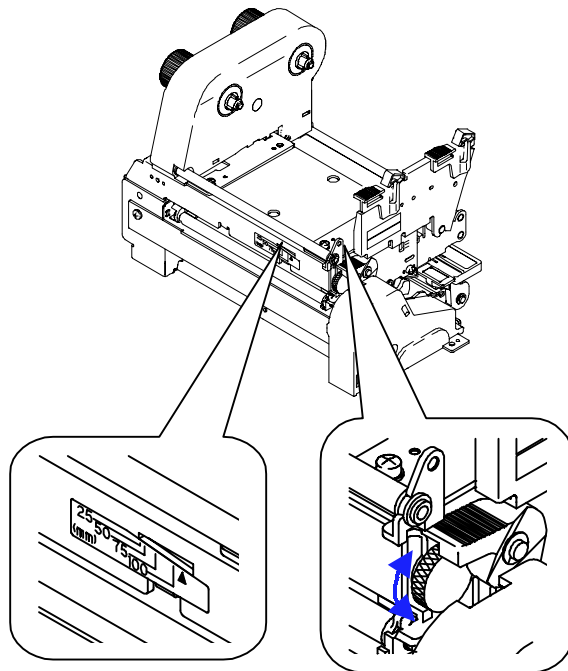
1. Looking at the check window on the upper frame, align the mark (the left edge of white plastic) with the width of the paper. (The print head is closed.)
 2. Make fine adjustments, checking the print.
 - (a) When the print on right side is too light: Move the mark to the right by turning the head pressure adjustment screw clockwise.
 - (b) When the print on the left side is too light: Move the mark to the left by turning the head pressure adjustment screw counterclockwise.
- * These adjustments are useful for preventing ribbon wrinkle or paper skew. For more details, consult our service personnel.

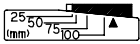
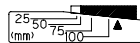
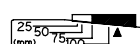

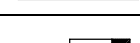
Check window	Width of paper	
		25.4 mm
	50.8 mm	2 in
	76.2 mm	3 in
	101.6 mm	4 in
	When ribbon wrinkles or paper skews with paper width of 4 in or more	
	Factory setting	

3 Using Narrow Ribbon (Ribbon Tension Adjustments)

If ribbon slips or wrinkles during printing, adjust the ribbon tension.

The printer has already been factory-set to the ribbon width of 114 mm (4.5 in). When you use a different ribbon, adjust the ribbon tension as follows:

1. Hold the ribbon roll by one hand on the side of the knob you operate so that it does not turn.
2. Slightly push the knob to the ribbon roll and turn it until the stopper comes to the desired position.
3. Gradually release the knob so that the stopper fits in the groove on the side of the knob.

Set values to each ribbon width:

*: Factory setting

Knob on ribbon winding section	Knob on ribbon feeding section	Ribbon width
5	5	Adjustments when ribbon slipping occurs
4	4	25.4 mm (1 in) 50.8 mm (2 in)
3	3	76.2 mm (3 in)
2	2	101.6 mm (4 in)
1*	1*	Adjustments when ribbon wrinkle occurs.

4. Perform printing and check for ribbon wrinkle or slipping. If it s occurs, adjust it according to the following procedure:
 - (a) Ribbon wrinkles: Increase the tension on the ribbon winding section.
 - (b) Ribbon slips: Decrease the tension on the ribbon feeding section.

If it is not resolved even when the tension on the ribbon feeding section is set to 5 (Mild), increase the tension on the ribbon winding section.

* If ribbon problems are not resolved, consult our service personnel.

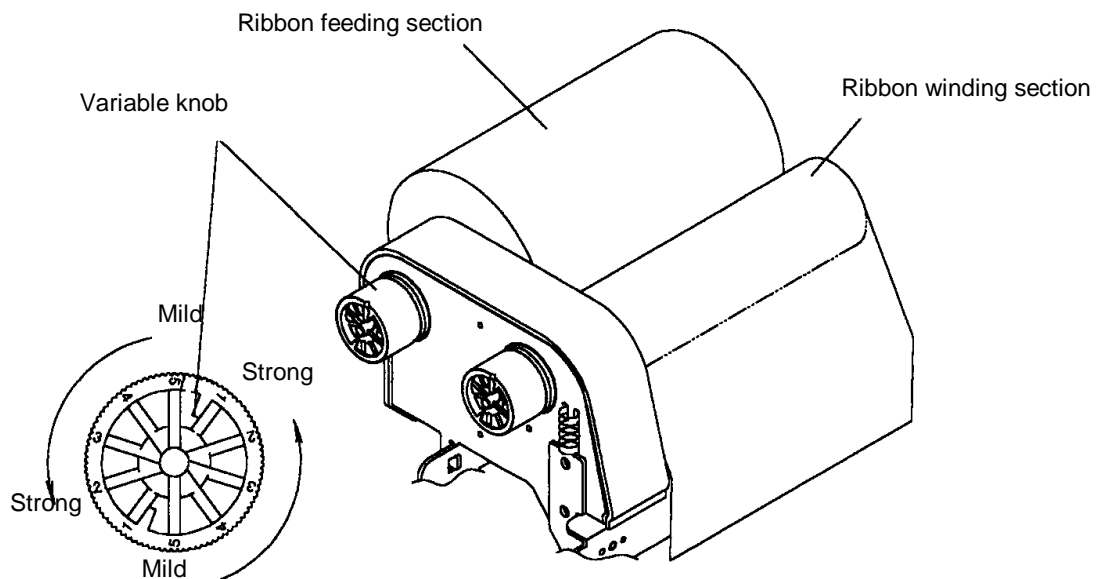

4 Adjustable Sensor (For CLP-7001/7401)

* The adjustable sensor is the optional for CLP-7002.

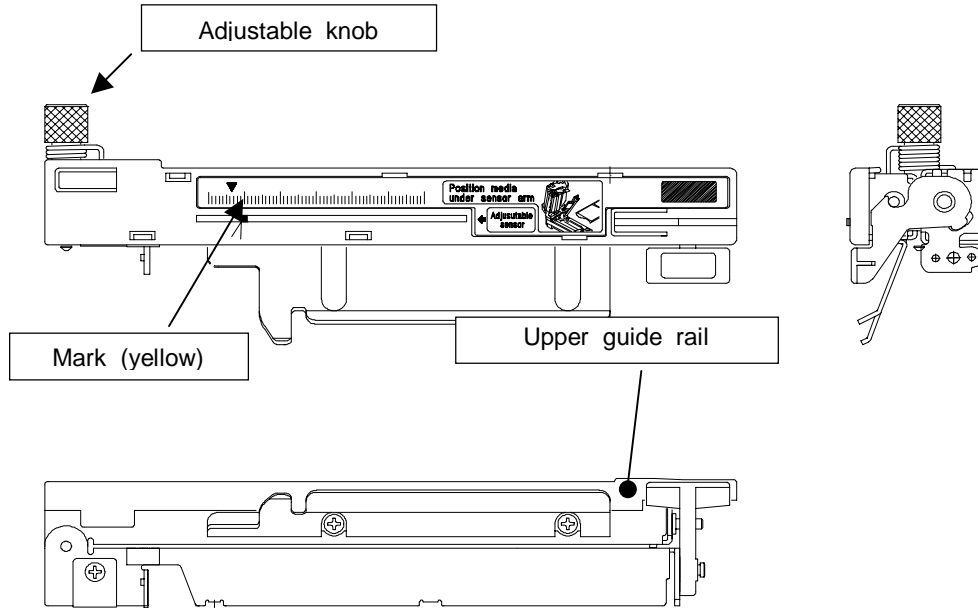

Operating procedure:

1. Move the adjustable sensor to your required detection position by tuning the adjustable knob. Measure your detection position beforehand. To set the detection position, align the scale marking on top of the upper guide rail with the sensor position mark (yellow) on the upper of the sensor. The movable range of the adjustable sensor is shown below.
2. Set the liner and close the upper guide rail and set voltage to 3V.

* For voltage setting, see Section 5: System Maintenance Mode, Chapter 2.

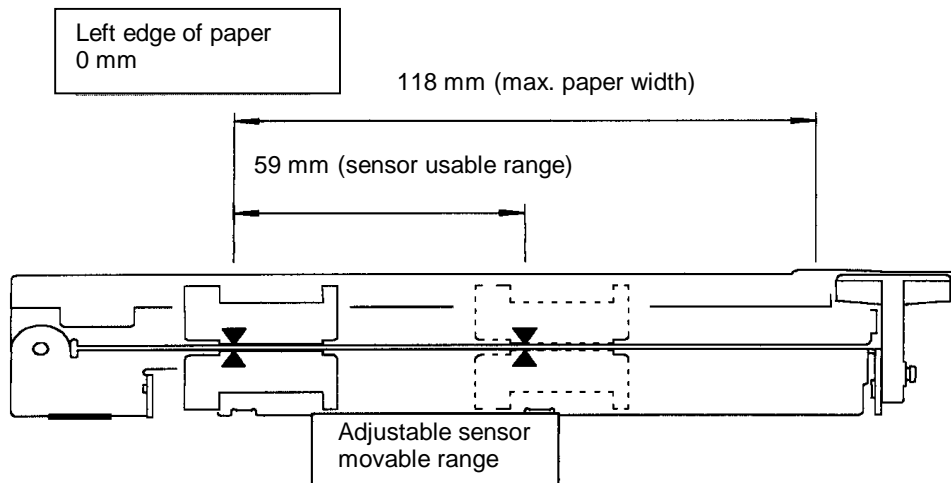

5 Cleaning

Wipe off any foreign matter such as ribbon or paper residue, dust and adhesive substance stuck to the thermal head, ribbon guide roller, platen etc with the accessory cleaning pen or a soft cloth soaked in ethyl alcohol. Cleaning of the thermal head is essential to guarantee print quality and extend print head life especially when printing on the direct-thermal paper for long periods.

Caution: Do not use solvent other than ethyl alcohol such as benzene and thinner that will dissolve plastic.

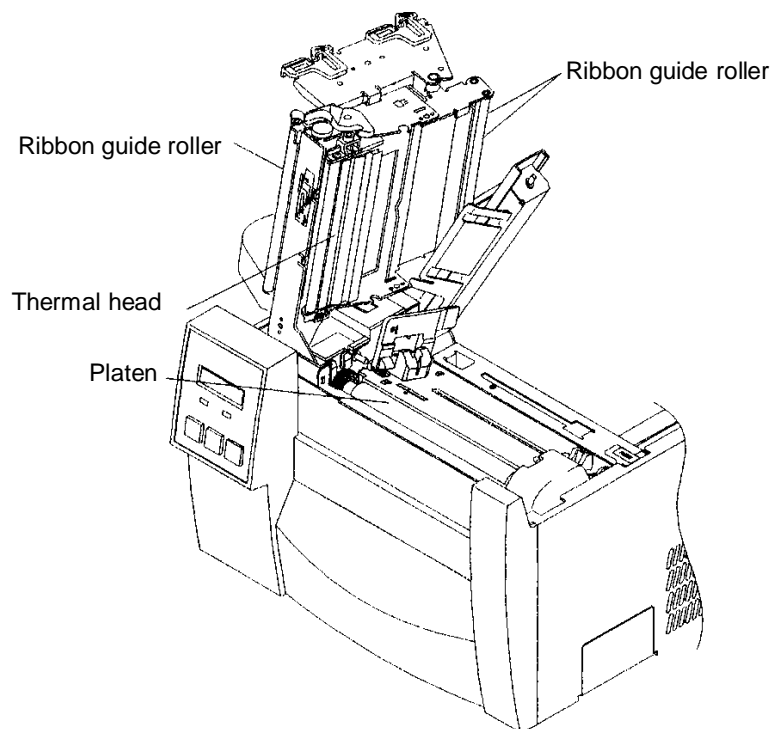

Chapter 5

Troubleshooting

- 1 Error Messages
- 2 Power Troubleshooting
- 3 Paper Feed Troubleshooting
- 4 Ribbon Feed Troubleshooting
- 5 Print Troubleshooting
- 6 Interface Troubleshooting

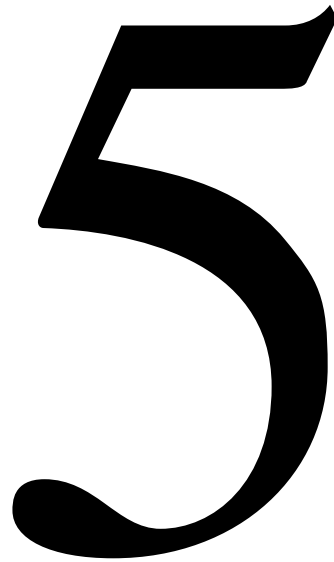

1 Error Messages

When there is a problem with the printer:

- A buzzer sounds.
- The error indicator lights up.
- An error message is displayed on the LCD screen.

Error descriptions and corrective actions are shown below.

1 Error descriptions and indications

Description	Indication	LED	Buzzer
Battery dead (for clock and backup RAM)	Battery	Lights	Sounds long
Head temperature low	ColdHead	Lights	Sounds long
PCB temperature low	Cold PCB	Lights	Sounds long
Head resistance value abnormal (error contents and head information repeatedly displayed) Rank: Rank of head resistance value Average: Average of resistance values (A/D reading value in decimal system) Maximum: Max. resistance value Minimum: Min. resistance value	Head Err Rank *** Ave.*** Max.*** Min.***	Lights	Sounds long
Communication error (receive buffer overrun)	OverFlow	Lights	Sounds long
Communication error (parity, framing)	S/I Err	Lights	Sounds long
Communication error (transmit buffer overflow)	HostBusy T.D.Full	Blinks	Sounds short 3 times
Pause key pressed	Pause	--	--
Pause command reception (remote control)	Pause	--	--
Head overheat	OverHeat Cooling	Blinks	Sounds short 3 times
Stop key pressed	Stop	--	Sounds short 3 times
Stop command reception (remote control)	Cancel	--	--
Mechanism head open	HeadOpen	Lights	Sounds short 3 times
Paper end (paper out)	PaperEnd	Lights	Sounds short 3 times
Paper out (paper position cannot be detected) (error contents and sensor information repeatedly displayed) M command: Sets length for detection miss checking with system command M Maximum: Max. value of sensor reading voltage Minimum: Min. value of sensor reading voltage	PaperErr M CMMD Max*. **V Min*. **V	Lights	Sounds short 3 times
Ribbon end	RibonOut	Lights	Sounds short 3 times
PCB overheat (PCB or sensor abnormal)	OverHeat	Lights	Sounds short 3 times
Fan stop	Fan stop	Blinks	Sounds short 3 times
Option board abnormal	OP Err	Lights	Sounds short 3 times
Auto-cutter abnormal (such as poor engagement)	Cut Err	Lights	Sounds short 3 times
ROM checksum error	ROM Err	Lights	Sounds long
RAM check error	RAM Err	Lights	Sounds long

1 Error Messages

2 Error indications and corrective actions

Indication	Description	Corrective actions
Battery	Battery dead	<p>Automatically returned after displaying the error for a certain time.</p> <p>Change the lithium battery (CR2032). Note: Contact our service personnel to replace the battery.</p> <p>If the battery runs down, the realtime clock will stop and the contents of the memory switch will be lost.</p>
ColdHead	Head temperature low	<p>Automatically returned after displaying the error for a certain time.</p> <p>Raise the temperature around the printer. Print density becomes low and print quality becomes inferior when the head temperature is low.</p>
Cold PCB	PCB temperature low	<p>Automatically returned after displaying the error for a certain time.</p> <p>Raise the temperature around the printer. Print density becomes low and print quality becomes inferior when the head temperature is low.</p>
Head Err	Head resistance value abnormal	<p>Check the contents and clear with the Stop key. Replace the print head.</p> <p>Print quality is affected at the section where the head resistance value is abnormal.</p>
OverFlow	Communication error (receive buffer overrun)	<p>Check the contents and clear with the Stop key. Correct the communication control system or communication cable abnormalities.</p>
S/I Err	Communication error (parity, framing)	<p>Check the contents and clear with the Stop key. Correct the communication parameter or communication cable abnormalities.</p>
HostBusy T.D.Full	Communication error (transmit buffer overflow)	Automatically returned if the computer receives data and the buffer becomes empty.
Pause	Pause key pressed	<p>Pressing the Pause key again resumes printing.</p> <p>If the Stop key is pressed, the stored printing contents are discarded and 'ON LINE' turns on.</p>
Pause	Pause command reception (communication control)	Same as above.

1 Error Messages

Indication	Description	Corrective actions
OverHeat Cooling	Head overheat	Wait until the head temperature goes down. When the temperature becomes low, the remaining printing resumes.
Stop	Stop key pressed	Enters a pause after displaying 'Stop' by the Stop command. If the Pause key is pressed, the printing will resume. If the Stop key is pressed again, the stored printing contents are discarded and 'ON LINE' turns on.
Cancel	Stop command reception (communication control)	Displays 'Stop' by the stop command, discards the remaining printing contents, and enters pause. If the Pause key is pressed, 'ON LINE' will turn on.
HeadOpen	Mechanism head open	Close the mechanism head.
PaperEnd	Paper end (paper out)	Install the paper.
PaperErr	Paper out (paper position cannot be detected)	Check the contents and clear with the Stop key. Correct the faulty setting of the paper detection (paper gap, black line, continuous paper). Correct the faulty parameter for paper (max. length, continuous paper). Adjust the sensor or change to the paper that can accept the paper position detection. Specify the detection miss checking length with the M command. When the paper position cannot be detected during paper feeding by the specified length, it is judged error. Generally specify the length about three times the label length. In case of continuous paper, specify the label length with the C command. Difference between the maximum and minimum values of the sensor reading voltage must be 0.8 V or more. Sensor adjustments and check of paper characteristic (voltage checking) can be performed with the Maintenance mode.

1 Error Messages

Indication	Description	Corrective actions
RibonOut	Ribbon end	Check the contents and clear with the Stop key. Install the ribbon. Check that ribbon winds properly. Correct the faulty setting of the print mode (direct-thermal or thermal-transfer).
OverHeat	PCB overheat	Turn off the power and reset the printer. If this recurs, contact our service personnel.
Fan stop	Fan stops	Check for fan stop caused by the problems such as foreign matter in the air vent. Automatically returned if the fan turns again. If disassembling is needed to remove foreign matter or the problem cannot be resolved, contact our service personnel.
OP Err	Option board abnormal	Turn off the power and reset the printer. If this recurs, contact our service personnel.
Cut Err	Auto-cutter abnormal (such as poor engagement)	Check the contents and clear with the Stop key. If this cannot be cleared, turn off the power and remove foreign matter from the auto-cutter. If this recurs, contact our service personnel.
ROM Err	ROM checksum error	Turn off the power and reset the printer. If this recurs, contact our service personnel.
RAM Err	RAM check error	Turn off the power and reset the printer. If this recurs, contact our service personnel.
--	System error (such as timer or CPU malfunction)	First protect the system, then turn off the power and reset the printer. If this recurs, contact our service personnel.

2 Power Troubleshooting

Problem	Cause and remedy
No power even with power switch turned ON.	<ul style="list-style-type: none"> <li data-bbox="548 432 1377 512">• Power cord is not properly connected to the outlet. → Turn off the power switch and reconnect the power cord to the outlet properly. <li data-bbox="548 531 1377 611">• Power cord is not properly connected to the power inlet. → Turn off the power switch and reconnect the power cord to the power inlet properly. <li data-bbox="548 630 1393 737">• Input voltage is not correct; input voltage is greater or less than the rated voltage. → Set input voltage within the rated voltage (puncture voltage may occur. Contact our service personnel). <li data-bbox="548 756 1435 888">• Correct RS-232C cable is not used. → Turn off the power switch and unplug the interface cable. Check that power is provided by turning on the power switch and use the correct RS-232C cable.

3 Paper Feed Troubleshooting

Problem	Cause and remedy
Paper doesn't feed.	<ul style="list-style-type: none"> • Wrong paper path. → Use correct path. (See Chapter 3) • Mechanism head is open. → Close the mechanism head.
Paper skew.	<ul style="list-style-type: none"> • Edge of paper is not in contact with the paper guide. → Slightly push the paper guide to the edge of the paper. (See Chapter 3) • Roll guide is not in contact with the roll paper. → Slightly push the roll guide to the roll paper. (See Chapter 3) • Head pressure is not correct. → Adjust it with the offset adjustment screw according to the width of the paper. (See Chapter 4)
Paper doesn't align with the print position.	<ul style="list-style-type: none"> • Setting mode is not correct. → Check whether the setting mode is for paper gap or black line sensor and if it is not, change it. (See Chapter 2) • Paper gap (black line) sensor adjustment failure. → Adjust the voltage of the paper gap or black line sensor from the voltage setting in the system maintenance mode. (See Chapter 2) • Transfer data is abnormal. → If the contents of the transfer data are incorrect, set them properly again.

4 Ribbon Feed Troubleshooting

Problem	Cause and remedy
Ribbon doesn't wind.	<ul style="list-style-type: none"> • Wrong ribbon path. → Use correct path. (See Chapter 3) • Ribbon winding direction is reversed. → Set it properly. (See Chapter 3) • Ribbon holder and winder tension is not correct. → Set it properly. (See Chapter 3) • Ribbon and paper are not proper. → Contact our service personnel.
Ribbon wrinkles.	<ul style="list-style-type: none"> • Ribbon holder and winder tension is not correct. → Set it properly. • Print density (heating factor) is not correct. → Correct the parameter of the Hnn command in the printing contents definition mode. (See Appendixes) • Angle of ribbon guide bar is not correct. → Contact our service personnel to adjust the ribbon guide bar. • Head pressure doesn't match paper width. → If not, the ribbon may wrinkle. Adjust head pressure with the adjustment screw. (See Chapter 4) • Ribbon and paper are not proper. → Contact our service personnel.

5 Print Troubleshooting

Problem	Cause and remedy	
Printing doesn't start.	<ul style="list-style-type: none"> • Power to the printer is not turned on. • Printer is not properly connected to the computer. • Printer configuration setting is not proper. 	<ul style="list-style-type: none"> → Turn on the power switch. If power is not provided, follow the descriptions on Section 2: Power Troubleshooting, Chapter 5. → Turn off the power switch and connect it properly. (See Chapter 1) → Correct the printer configuration setting. (See Chapter 2)
Missing lines.	<ul style="list-style-type: none"> • Print head connector connection fails. 	<ul style="list-style-type: none"> → If the print head connector is not connected properly, insert it properly.
Dropouts.	<ul style="list-style-type: none"> • Print head is dirty. • Platen is dirty. <p data-bbox="589 1089 1365 1119">Note: If those cannot be removed, contact our service personnel.</p>	<ul style="list-style-type: none"> → Check that the area around the print head heating body is not dirty. If dirty, clean it with the cleaning pen or a soft cloth soaked in ethyl alcohol etc. (See Chapter 4) → Remove label, ribbon or paper residue, dust etc stuck to the platen. (See Chapter 4)
Print is too light or dark.	<ul style="list-style-type: none"> • Ink ribbon and paper are not the recommended type. • Paper quality doesn't match the print head offset. • Paper width doesn't match the print head pressure. • Printer setup mode is not correct. • Printing energy setting level is not proper. 	<ul style="list-style-type: none"> → Change to the recommended type after checking the maker and model serial number of the ink ribbon and paper. → Adjust the print head offset. See Section 1: Head Offset Adjustments, Chapter 4. → Adjust the print head pressure. See Section 2: Head Pressure Adjustments, Chapter 4. → Check whether the printer setup mode is for direct-thermal or thermal-transfer printing, and change it as necessary. (See Chapter 2) → Check the set value of the printing energy level, and adjust it as necessary. (See the Command Reference separately available)
Other printing abnormalities	<ul style="list-style-type: none"> • Check the error message on LCD screen and correct it according to the descriptions on Section 1: Error Messages, Chapter 5. 	

6 Interface Troubleshooting

Problem	Cause and remedy
<p>Printer doesn't print.</p> <p>Print disordered.</p> <p>Error message is displayed and printer doesn't print.</p>	<p>The following may be the probable causes:</p> <ul style="list-style-type: none"> <li data-bbox="548 512 1365 569">• Interface cable is not properly connected. → Check that the interface cable is connected properly. <li data-bbox="548 583 1127 640">• Interface cable is not the standard type. → Replace it. <li data-bbox="548 655 1406 764">• Communication parameter setting is not correct. → Set the system maintenance mode from the control panel and check/correct the communication parameter value. (See Chapter 2)

Appendixes

- 1 Options
- 2 Specifications

APPENDIXES

1 Options

● Factory and dealer (reseller) options

1. Auto-Cutter			
Specifications	Cutting method	Rotary cutter	
	Max. thickness of cut paper	0.25 mm	0.01 in
	Min. length of cut paper	25.4 mm	1.0 in
Remarks	See the user's manual of the auto-cutter for details.		

2. Peeler			
Specifications	Width of paper	25.4–118 mm	1–4.65 in
	Max. diameter for roll paper	203 mm	8 in
	Inner diameter for roll paper	76 mm or more	3 in or more
	Min. length of label	25.4 mm	1 in
	Thickness of paper	Max. 0.17 mm	Max. 0.0067 in
	Thickness of liner of label	Max. 0.07 mm	Max. 0.0027 in
	Unusable paper	Special paper (Whitepet, etc.) or too flexible paper causing jams	
Remarks	See the user's manual of the peeler for details.		

3. Adjustable sensor	
* The adjustable sensor is the optional for CLP-7002.	

1 Options

● User options

4. PCMCIA Memory Card			
Summary	Card type	PCMCIA Type I flash memory card	
	PCMCIA memory card applications	Storing print format files	Data in the field register area can be stored and loaded
		Storing graphic data	Graphic data such as a corporate logo can be stored and recalled from the PCMCIA memory card and combined with field data and printed
	Storing downloaded fonts	Downloaded HP Soft fonts can be stored	

Installation

1. Turn off the power to the printer.
2. Remove the PCMCIA memory card cover at the bottom of the printer (see figure).
3. Insert the memory card.
4. Replace the PCMCIA memory card cover.

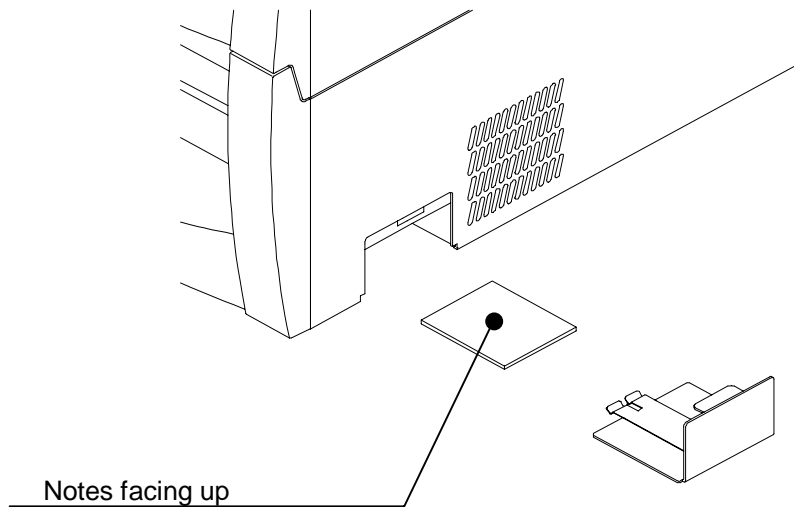

CAUTION

- Before use, carefully read and understand the instructions regarding the PCMCIA memory card .
- Do not insert or remove the PCMCIA memory card before the power to the printer is turned off.
- Always close the PCMCIA memory card cover to keep out foreign matter such as particles of dust.
- If the PCMCIA memory card write failure occurs, check it with the test command (STX.w).

2 Specifications

● Main Specifications

Item		CLP-7001/7002		CLP-7401	
Printing	Resolution	Main scanning line density: 203 dots/in (8 dots/mm)		Main scanning line density: 400 dots/in (15.75 dots/mm)	
		Sub-scanning line density: 203 dots/in (8 dots/mm)		Sub-scanning line density: 406 dots/in (16 dots/mm)	
	Printing method	Direct-thermal or thermal-transfer printing		←	
	Max. print width	104 mm	4.1 in	105.7 mm	4.2 in
	Max. print length	812.8 mm	32 in	254 mm	10 in
	Print density	Adjustable with software		←	
Printing speed	Printing speed setting	2–7 in/sec in one-inch units (for CLP-7001) 2–6 in/sec (for CLP-7002)		1–4 in/sec in one-inch units	
Print mode	Batch mode	Performs normal printing (single or multiple sheets)		←	
	Peel mode	Peels label from the liner after printing label		←	
	Cut mode	Prints and cuts by the specified number of sheets (label back-feeding enabled)		←	
	Tear-off mode	Feeds back paper to the print starting position after tearing paper		←	
Paper	Type of paper	Roll or fanfold (continuous label, die-cut, continuous tag or ticket)		←	
	Kinds of paper	Direct-thermal or thermal-transfer paper		←	
	Max. liner width	118 mm	4.65 in	←	
	Min. liner width	25.4 mm	1 in	←	
	Min. label width	7.62 mm	0.3 in	←	
	Min. paper pitch	5.08 mm	0.2 in	←	
	Max. paper thickness	0.254 mm	0.01 in	←	
	Min. paper thickness	0.0635 mm	0.0025 in	←	
	On-board roll paper diam.	Max. outer diam.: 203 mm Paper core: 38–76 mm	8 in 1.5–3 in	←	
Ribbon	Width	25.4–114 mm (1–4.5 in) freely adjustable		←	
	Length, max.	360 m	1,181 ft	←	
	Max. outer diam.	74 mm	2.91 in	←	
	Paper core inner diam.	25.4 mm ±0.254 mm	1 in ±0.01 in	←	

2 Specifications

- Main Specifications

Item	Description		
Bar codes	Bar code on-board may vary depending on the model and destination. See the Command Reference for details		
	<ul style="list-style-type: none"> · CODE 3 of 9 · CODE 128 	<ul style="list-style-type: none"> · UPC-A · EAN13 	<ul style="list-style-type: none"> · UPC-B · EAN8
Fonts	Font and size on-board may vary depending on the model and destination. See the Command Reference for details		
	<ul style="list-style-type: none"> · Fixed pitch font · True type lusterizer 	<ul style="list-style-type: none"> · OCR-A, B 	<ul style="list-style-type: none"> · CG Triumvirate, CG Triumvirate Bold
Media detection sensors	Transparent-type sensor	Detects paper gap between labels, tag paper notch and paper out	
	Reflective-type sensor	Detects black line on back of paper and paper out	
	Ribbon end sensor	Detects ribbon out and end (holder speed)	
	Label peeling sensor (optional)		
	Paper top position (home position) adjustable with software		
Communication interface	Serial (RS-232C)		
	Parallel (In conformity with Centronics)		
Indications, keys and switches	LEDs	Power and Error	
	LCD	Displays printer status, error contents, mode switch contents etc	
	Control keys	Pause, Feed and Stop	
	Mode switch	Switches between direct-thermal and thermal-transfer and sets parameters for communication etc	
	Head-up detection sensor	Detects head open	
	Power switch	Turns on or off the power	
Options	By factory or dealer (reseller)	Auto-cutter, peeler or adjustable sensor (note that adjustable sensor is standard for CLP-7001/7401)	
	By user	PCMCIA memory card	
Dimensions and weight	Height	251 mm	9.9 in
	Width	255 mm	10.0 in
	Depth	428 mm	16.9 in
	Weight	11.0 kg	24.2 lbs
Power	Voltage 120V system	120V: -10%+6%, 2.5A, 60Hz (U.S.A., Canada)	
	Voltage 230V system	220V–240V: -10%+6%, 1.2A, 50/60Hz (Europe)	

2 Specifications

• Main Specifications

Item	Description		
Standards	120V system	120V: U.S.A./ Canada	UL 1950
		CSA No. 950	
		FCC Part 15 Subpart B class A	
	230V system	220V–240V: Europe	EN 60950
			EN 55022 class A
			EN 55024
EN 61000-3-2, 61000-3-3			
Environment	Operating conditions	Temperature: 5–35°C (41–95°F) Humidity: 30–80% (non-condensing)	
	Storage	Temperature: -20–60°C (-68–140°F) Humidity: 5–85%	
	Ventilation	<ul style="list-style-type: none"> · Convection · Air vent be away from wall etc · Danger of smoke or fire 	
	Dust	Free from conductive or corrosive matter	

2 Specifications

● Interface

The printer is connected to a computer and prints labels according to the command from the computer. Two systems of interface connection to a computer are shown below.

1. Serial interface: RS-232C

System	Asynchronous serial interface RS-232C
Connector	DSUB 25-pin
Handshaking	XON/XOFF and CTS/DTR
Receive buffer size	32K bytes Receiving data stops when the receive buffer reaches 2K bytes and resumes receiving data when the receive buffer reaches 4K bytes
Baud rate	300, 600, 1200, 2400, 4800, 9600, 19200, 38400 bps
Bit length	7- or 8-bit
Stop bit	Fixed When printer is receiving data, stop bit is fixed at 1, and when printer is transmitting data, stop bit is fixed at 2. But computer can transmit or receive data, regardless of stop bit at 1 or 2
Parity	No

2. Parallel interface: In conformity with Centronics

System	8-bit parallel
Connector	36-pin unphenol type
Synchronous system	Strobe pulse
Handshaking	ACKNLG and BUSY signals
Signal level	TTL

3. RS-232C loopback test

After connector wiring as shown in the figure, place the printer into self-test mode. The printer will receive data that has been transmitted by printer itself and the test of receiving and transmitting data will be performed.

RS-232C loopback test

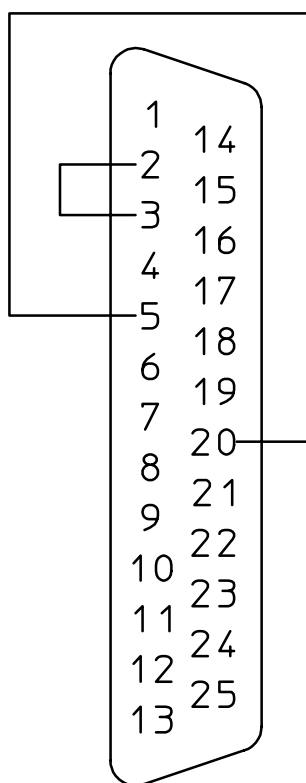

2 Specifications

- Interface Specifications

4. RS-232C protocol

1) X-ON/X-OFF system (see figure)

This is a control system in which the data transmitting request signal (X-ON (11H) code) and the data transmitting stop signal (X-OFF (13H) code) are output.

Requirements of output of X-ON code:

- When the power is switched to ON.
- When the receive buffer has less than 2K bytes available, the X -OFF code is output, and the receive buffer has at least 4K bytes available.

Requirements of output of X-OFF code:

- When printer error occurs.
- When the receive buffer has less than 2K bytes available.

Buffer in use

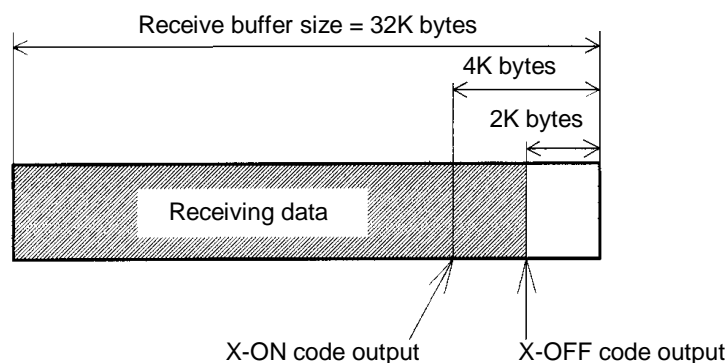

Note: Even if each code is ready for output, the same code will not be transmitted twice successively (except when the power is turned on or the printer is reset from the control panel).

2) Ready/Busy system (see figure)

This is a control system in which the DTR is output at Ready (High) or Busy (Low) level.

Requirements of output of DTR 'High':

- When the printer is 'ON LINE.'
- When the receive buffer has less than 2K bytes available. When this condition is detected, the printer keeps a 'Low' level until the receive buffer has at least 4K bytes available.
- When printer alarms such as the printer switched to 'OFF LINE' occur.

2 Specifications

- Interface Specifications

5. Interface pin assignment

The serial and parallel pin assignment tables are shown below.

■ Serial interface pin assignment table

Pin No.	Signal	Input/Output	Description
1	F.GND	Output	Frame ground
2	TXD	Output	RS-232C output data
3	RXD	Input	RS-232C input data
4	RTS	Output	RS-232C (pull up to +5V with 2 K Ω)
5	CTS	Input	RS-232C data transmission on computer enabled
6	NC	–	Not connected
7	S.GND	Output	Signal ground
8	NC	–	Not connected
9	NC	–	Not connected
10	NC	–	Not connected
11	NC	–	Not connected
12	NC	–	Not connected
13	L.GND	Output	Control system ground
14	VCCs	Output	Control system power +5 V (max. service current 0.05A)
15	NC	–	Not connected
16	NC	–	Not connected
17	NC	–	Not connected
18	NC	–	Not connected
19	NC	–	Not connected
20	DTR	Output	RS-232C printer data receiving enabled
21	NC	–	Not connected
22	NC	–	Not connected
23	NC	–	Not connected
24	NC	–	Not connected
25	NC	–	Not connected

2 Specifications

- Interface Specifications

- Parallel interface pin assignment table

Pin No.	Signal	Input/Output	Description
1	$\overline{\text{STROBE}}$	Input	8-bit data reading signal
2–9	DATA1-8	Input	8-bit parallel signal
10	$\overline{\text{ACKNLG}}$	Output	8-bit data request signal
11	BUSY	Output	Signal specifying printer Busy
12	PERROR	Output	Signal specifying paper out
13	SELECT	Output	Signal specifying printer 'ON LINE' (printing enabled) or 'OFF LINE' (pausing)
14	$\overline{\text{AUTOFD}}$	Input	Invalidness (ignorance)
15	NC	–	Not used
16	S.GND	Output	Signal ground
17	FGND	Output	Frame ground
18	P.L.H	Output	Signal specifying Peripheral Logic High (pull up to +5V with 2 K Ω)
19–30	GND	Output	Ground for twisted pair return
31	$\overline{\text{INIT}}$	Input	Printer reset
32	$\overline{\text{FAULT}}$	Output	Signal specifying printer error
33–35	NC	–	Not used
36	$\overline{\text{SELECTIN}}$	Input	Invalidness (ignorance)

2 Specifications

● Example of Connection to a Computer

When RS-232C is used:

(IBM PC compatible)

Communication control: XON/XOFF or CTS/DTR

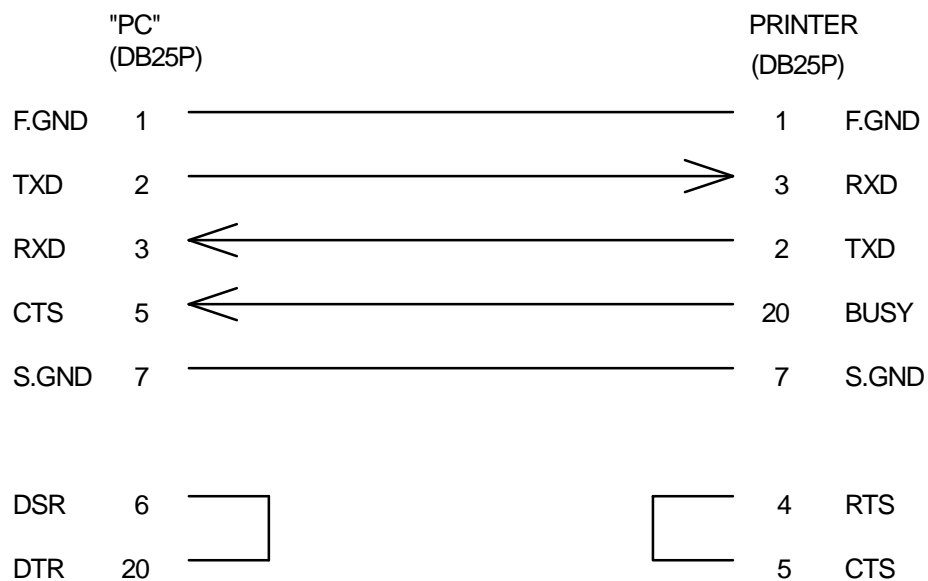

2 Specifications

● Tear-Off Function

The tear-off function eliminates the waste of labels when tearing manually. It allows the paper to automatically advance to the tear position after printing.

When this function is turned on, paper will be fed to the manual tear position after printing. The printer will feed back paper to the start print position when the next print job is sent.

If data is transmitted continuously from the computer, the tear-off function will be suppressed to increase throughput.

1. Turning Tear ON/OFF

Tear can be turned to ON or OFF from the control panel. Default is OFF.

Indications on the control panel are as follows

LCD screen	
Tear-off invalid	Tear-off valid
'Tear OFF'	'Tear ON'

2 Specifications

- Tear-Off Function

2. Tear-off when printing

- If set, the tear-off feature will start if no data is transmitted from the computer after printing. If data is transmitted continuously from the computer, the tear-off function will be suppressed. Tear-off is only performed for the final label of each batch processing. (The tear-off is not performed until the specified number of print sheets is completed.)
- Paper is fed to the tear position

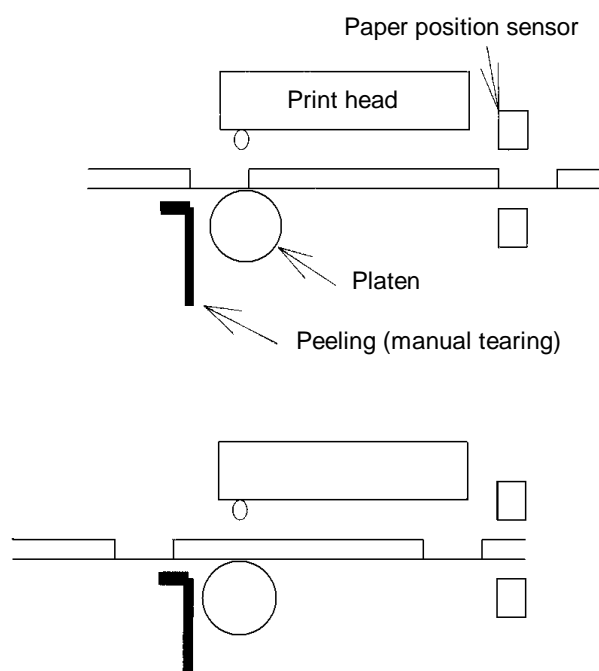

Tear-off will start if no data is transmitted after printing.

Paper is fed to the position where manual tearing is possible

- When manual tearing is needed, tear the label at this time.
- Performs next label printing.
When next print data is transmitted from the computer, the printer feeds back paper to the previous print completed position and resumes printing.

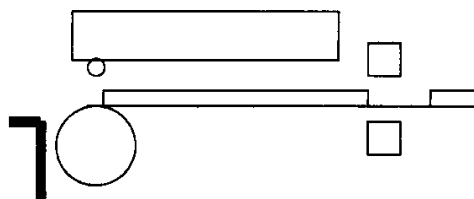

Paper is fed back to the Previous print completed position and printing resumes

2 Specifications

- Tear-Off Function

3. Tear-off when feeding

- The paper is fed to the tear position.
- When the manual tearing is needed, tear the label at this time.
- Perform next feeding or label printing.

If the Feed key is pressed or next print data is transmitted from the computer, the printer will feed back paper to the previous print completed position and resume feeding or printing.

4. Priority order

The following three functions (optional) cannot be performed simultaneously.

If commands for these three functions are received simultaneously, they will be executed in the following priority order:

- 1st: Auto-cutter
- 2nd: Peeler
- 3rd: Tear-off

2 Specifications

● Cut Position Adjustments

- The cut position can be specified with the 'fnnn' of the system -level commands. When the tear-off function is turned on, the following initialization value is set in the printer.
Initialization value: fnnn = f735 (73.5 mm)
The values higher or lower will increase or decrease the amount of feed in the tear-off.

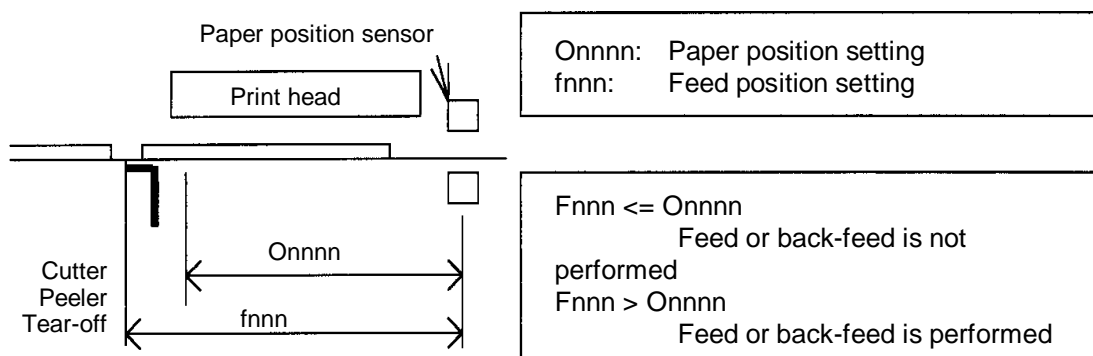

- Parameter initialization values
Initialization values of print and feed positions by each operating mode are described below.

unit: mm (in)

	Normal printing	Auto-cutter	Peeling	Tear-off	Minimum value
Print position (Onnnn, form offset)	55.9 (2.2)	55.9 (2.2)	55.9 (2.2)	55.9 (2.2)	12.7 (0.5)
Feed position (fnnn)	55.9 (2.2)	86.4(3.4)	68.6(2.7)	73.7(2.9)	12.7(0.5)

Citizen America Corporation
831 S. Douglas Street, Suite 121
El Segundo, CA 90245
(310) 643-9825
U.S.A.

Citizen Systems Europe Ltd.
Mettinger Strasse 11
73728 Esslingen
Germany

337 Bath Road, Slough
Berkshire, SL1 5PR
United Kingdom

JE99507-01
(70903891)

Printed in Japan