



# CWHDI-TxRx

## HDMI Wireless Transmitter & Receiver Set

OPERATION MANUAL





## *Precautions*

Failure to follow the precautions described below may cause damage to this HDMI device and void the warranty.

- DO NOT open the case. This will void the warranty, if you find a problem with this product, please return it to your retailer or seller who will assist you or provide you with a solution.
- DO NOT use third-Party AC adaptors or power cords. This may damage the device.
- DO NOT bump, jar or drop the product because it may cause damage and void the warranty.
- DO NOT allow liquids to come into contact with the units because they may cause damage.



## Table of Contents

1.	Introduction	1
2.	Features	1
3.	Package Contents	2
4.	Operation Controls and Functions	3
4.1	Transmitter	3
4.1.1.	Front Panel	3
4.1.2.	Rear Panel	4
4.2	Receiver	5
4.2.1.	Front Panel	5
4.2.2.	Rear Panel	6
5.	Remote Control	7
6.	Connection Diagram	8
7.	Specifications	9
8.	Troubleshooting	10





## 1. Introduction

This wireless HDMI transmitter and receiver set uses baseband technology with a Wireless High Definition Interface (WHDI) to deliver uncompressed HD video and audio up to 15~30 metres open field, while maintaining superb, wire-equivalent quality and robustness with no latency. The transmitter and receiver both come with embedded antennas.

## 2. Features

- Uncompressed wireless transmission of HD video/ audio at an equivalent quality to using a cable connection.
- Supports common video resolutions including;
- HDTV: 480i/p, 576i/p, 720p, 1080i and 1080p(24fps/30fps)
- PC: VGA@60/72, SVGA@60/72, XGA@60/70.
- Transmission distance between 15~30 metres open field depending on environment, no line of sight required.
- Real time link, less than 1 millisecond latency
- Strong 256-bit AES based encryption for security.
- Video Data Rates 1.5Gbps.
- 5GHz licensed band, MIMO RF.
- Supports CEC functionality.
- Fully HDCP Compliant.
- Unicast and Multicast broadcast options.
- Auto shut down of both devices when one of them is switched off.
- Control Channel allows two-way communications at 10Kbps.



### 3. Package Contents

- Wireless HDMI Transmitter unit.
- Wireless HDMI Receiver unit.
- 2 x 5V/2.6A DC power supply adaptors.
- Operation Manual.
- CR-67 Transmitter Remote
- CR-68 Receiver Remote
- Device Stand x 2



## 4. Operation Controls and Functions

### 4.1 Transmitter

#### 4.1.1 Front Panel

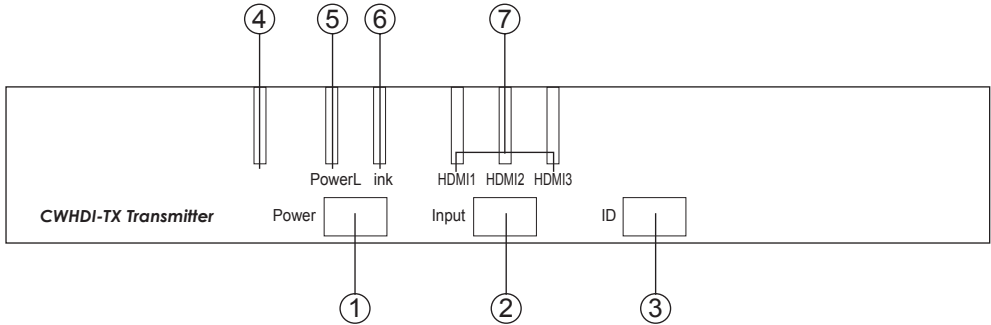

1. Power button: Press to turn the system ON/OFF - paired units will both turn on/off together when this button is pressed on either unit.
2. Input button: Press to select input source (1/2/3).
3. ID button: Press to initialise ID reset procedure and re-link units if necessary\*

\*These sets are already paired before they leave the factory so it is usually not necessary for you to reset them again unless the units have been unpaired.

If you need to re-link the units, press the transmitter "ID" button and hold for two seconds (the Link LED will start to flash quickly), then press the receiver "ID" button and hold for two seconds and wait for the system to pair. It is not necessary to press both the transmitter and receiver ID buttons at the same time.

Press and hold the ID button for more than 10 seconds to switch to a different broadcast mode, the two modes are unicast and multicast. Unicast mode means that the transmitter transmits to only one paired receiver. In multicast mode, the transmitter transmits to multiple receivers. A Green power LED indicates the unit is in Unicast mode and a red power LED indicates it is switched to multicast Mode.

The factory default is Unicast mode. We recommend that you use this mode for household use.

Note: Due to the nature of the transmission, the multicast mode has no uplink and therefore no bi-directional communication between the Transmitter and Receiver. This results in the following limitations:

- HDCP protected content can not be transmitted.



- CEC and EDID repeater functionalities cannot be supported.
  - Multicast mode is not HDCP compliant.
4. IR sensor.
  5. Power LED: The LED will illuminate when power is ON.
  6. Link LED: The LED flashes quickly during initial link procedure, flashes slowly during signal confirmation & remains solid when the link is established.
  7. Input indicator LED: The relevant LED will illuminate to indicate which input source is currently selected and being routed to the HDMI display.

#### 4.1.2 Rear Panel

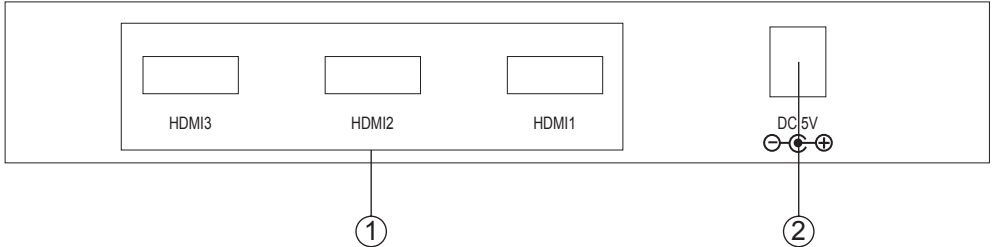

1. HDMI 1/2/3 Inputs: Connect each input to the HDMI output of your source equipment such as a DVD player or set-top-box.
2. Power: Plug the 5V DC power supply into this unit and connect the adaptor to an AC wall outlet.



## 4. Operation Controls and Functions

### 4.2 Receiver

#### 4.2.1 Front Panel

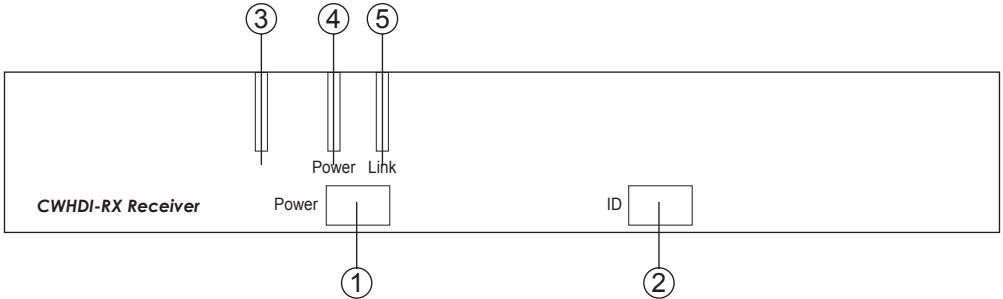

1. Power button: Press to turn the system ON/OFF - paired units will both turn on/off together when this button is pressed on either unit.
2. ID button – press to initialise ID procedure.

If you need to re-link the units, press the transmitter “ID” button and hold for two seconds (the Link LED will start to flash quickly), then press the receiver “ID” button and hold for 2 seconds and wait for the system to pair. It is not necessary to press both the transmitter and receiver ID buttons at the same time.

Press and hold the ID button for more than 10 seconds to switch to a different broadcast mode, the two modes are unicast and multicast. A Green power LED indicates the unit is in Unicast mode and a red power LED indicates it is switched to multicast Mode. The factory default is Unicast mode. We recommend you use this mode for household use.

3. IR sensor.
4. Power LED: The LED will illuminate when power is ON.
5. Link LED: The LED flashes quickly during initial link procedure, flashes slowly during signal confirmation & remains solid when the link is established.





#### 4.2.2 Rear Panel

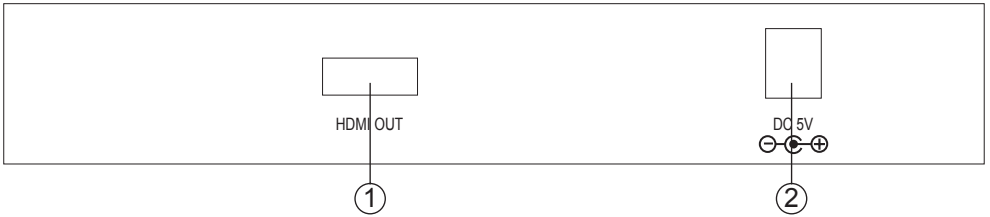

1. HDMI output: Connect this HDMI output to the HDMI input of your display with a HDMI cable.
2. Power: Plug the 5V DC power supply into this unit and connect the adaptor to an AC wall outlet.



## 5. Remote Control

1. Power: Press to turn the device ON/OFF.
2. ID: Press transmitter remote's "ID" button for 2 seconds and then receiver remote's "ID" for 2 seconds and wait for the system to pair. These systems are already paired before they leave the factory so it is not usually necessary for you to have to re-link the units.
3. (transmitter remote only) Input source selection: Press 1, 2 or 3 to select your desired input source. You can use this remote at the receiver end to select a different input.

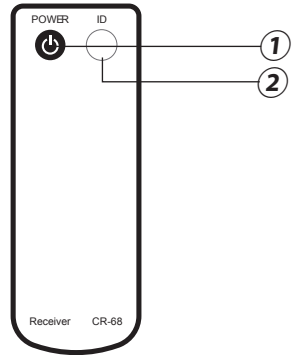
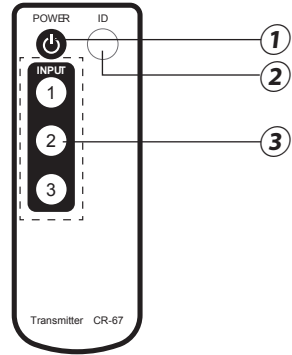



## 6. Connection Diagram

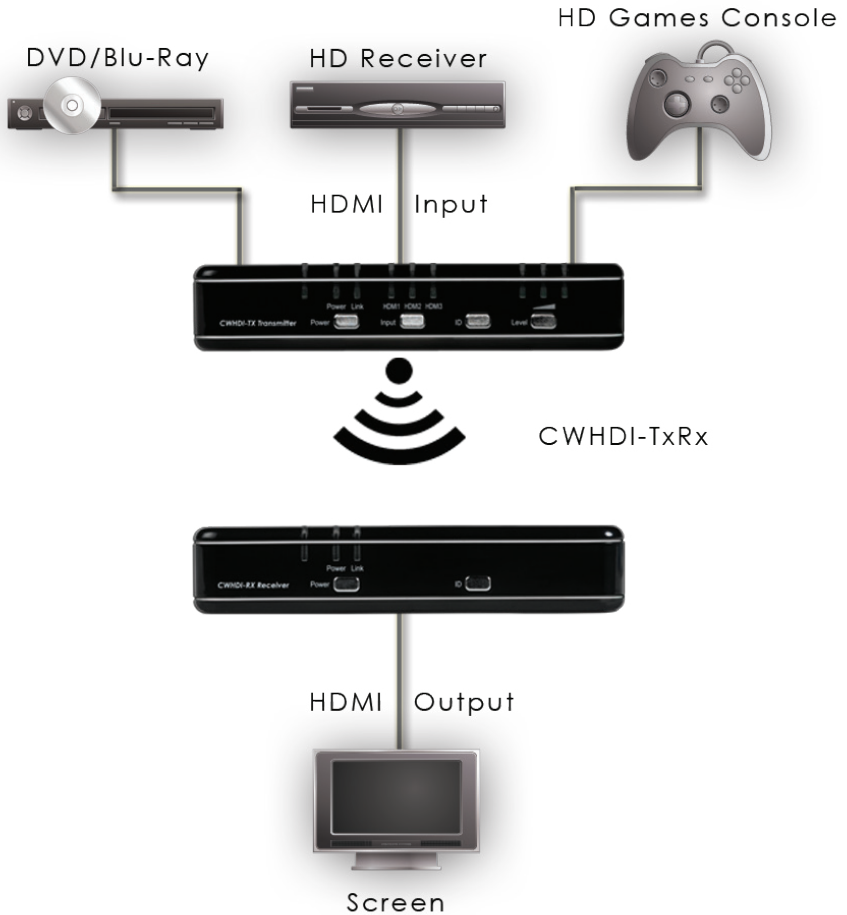



## 7. Specifications

Radio Power	Transmit power is configurable up to 63mW (+18dBm)
Video Resolutuions	480i/p, 576i/p, 720p, 1080i and 1080p(24fps/30fps), VGA@60/72, SVGA@60/72, XGA@60/70
Frequencies Supported	4.9 ~ 5.9 GHz
Modulation	OFDM MIMO with WHDITH video-modem Technology
Bandwidth	20MHz
Wireless Range	15 ~ 30 metres open field
Antenna	Transmitter: 4 transmit antennas and 1 recieve antenna Receiver: 5 receiver antennas and 1 transmit antenna
System Features	Automatic Transmission Power Control (ATPC) for best power performance. Automatic Frequency Selection (AFS) for avoiding interference.
Digital Video Interface	Up to 24bit RGB or YCbCr (4:4:4)
Digital Audio Interface	PCM 2ch, DTS 5.1, AC3 5.1
System Latency	Less than 1 millisecond delay between video/audio source & display
Security	Strong 256 bit AES-Based Encryption
Input ports	3 x HDMI
Output port	1 x HDMI
Power Supply	5V/2.6A DC (US/EU standards, CE/FCC/UL certified)
Dimensions (mm)	162.6 (W) x 164.5 (D) x 33.5 (H)
Weight (g)	Transmitter: 348 Receiver: 316
Chassis Material	Plastic
Silk Skin Colour	Piano Black
Operating Temp.	0°C ~ 40°C
Power Consumption	Transmitter: 1.95W Receiver: 1.62W



## 8. Troubleshooting

Situation	Check Point/s
Power LED does not illuminate when power is ON.	<ol style="list-style-type: none"> <li>1. Check the right adaptor is being used - 5V/2.6 A is the correct adaptor.</li> <li>2. Check all power connectors are plugged in correctly.</li> <li>3. Press the power buttons to turn on the devices</li> </ol>
After powering up Tx & Rx, the Link LEDs are flashing quickly / slowly without displaying a picture.	<ol style="list-style-type: none"> <li>1. Ensure your connected screen is On, and has the correct HDMI input selected, otherwise the Receiver unit's link LED will flash.</li> <li>2. This is normal if the devices are pairing or learning, the LED will flash slowly when it is carrying out a signal confirmation. Once signal lock is confirmed the LED will remain on.</li> <li>3. If the LED flashes quickly for more than 3 minutes, perform an ID reset as described on page 3 of this manual.</li> <li>4. If the LED flashes slowly for more than 3 minutes, check the input selection on the transmitter and confirm a device is connected to that input.</li> </ol>
The Link LED remains on but no image is displayed or an unexpected image is displayed.	<ol style="list-style-type: none"> <li>1. Check if source's resolution is supported, the device can support up to 1080i and 1080p 24/30, please make sure the source is sending a supported resolution, and confirm that your display can also accept that resolution.</li> <li>2. Check that both the source and the display are HDCP compliant.</li> <li>3. Check that the TV is on the correct AV channel.</li> <li>4. Check all hdmi cables have a good physical connection to the Rx/Tx units and connected sources and display.</li> </ol>
Input LEDs do not illuminate.	If the display connected to the receiver unit is not turned on and set to the correct HDMI channel, the input LEDs will not illuminate.
Different colours on Power LED.	<p>A Red Power LED indicates multicast mode and a Green Power LED indicates Unicast mode.</p> <p>If the Tx's power LED is green but the Rx's is Red. Press and hold the Rx's ID key for 10 seconds to change to Unicast mode. In similar scenarios hold the ID button down on the appropriate unit to set it to the required broadcast mode. To change both units from one broadcast mode to the other carry out the procedure on both.</p>



[www.cypeurope.com](http://www.cypeurope.com)

