

TROUBLESHOOTING	
Problem	Solution
Unit will not operate	<p>Check to make sure the unit is plugged in</p> <p>Check to make sure the unit is on by turning the knob</p> <p>If the door is not shut properly, the unit will not operate.</p> <p>Make sure the filters are properly installed and firmly close the door.</p>
Decreased air flow	<p>If the filters have not been changed for a year or more, change the HEPA filters.</p> <p>Check to ensure nothing is blocking the air inlet and filtered air outlet.</p> <p>Ensure carbon filters are changed every 3-6 months</p>

For U.K. and Ireland only:

If the plug is not suitable for the socket outlets in your home, it can be removed and replaced by a plug of the correct type. Please refer to "Installation of a plug" below.

Installation of a plug Applicable to U.K. and Ireland.

The wires in the mains lead are coloured as such:

GREEN AND YELLOW - EARTH
BROWN - LIVE
BLUE - NEUTRAL

Please note that the colour of these mains wires may not correspond with the colour markings that identify the terminals in your plug.

Please proceed as follows:

The wire which is coloured GREEN AND YELLOW must be connected to the terminal which is marked with the letter 'E' or by the earth symbol \oplus or coloured GREEN AND YELLOW.

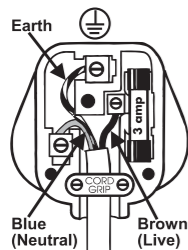

The BROWN coloured wire must be connected to the terminal, which is marked with the letter "L" or is coloured RED.

The BLUE coloured wire must be connected to the terminal, which is marked with the letter "N" or is coloured BLACK.

NOTE: If the terminals in the plug are not marked or if you are unsure or in doubt about the installation of the plug please contact a qualified electrician. If a 13A 3-pin plug is fitted, it must be an ASTA approved plug, conforming to BS1363 standard. Replacement 3A fuses must be BSI or ASTA BS1362 approved.

GUARANTEE

PLEASE KEEP YOUR RECEIPT AS THIS WILL BE REQUIRED FOR ANY CLAIMS UNDER THIS GUARANTEE.

- This appliance is guaranteed for 2 years.
- In the unlikely event of breakdown from a manufacturing related fault, please return it to the place of purchase, with your till receipt and a copy of this guarantee.
- The rights and benefits under this guarantee are additional to your statutory rights which are not affected by this guarantee.
- Holmes Products (Europe) Ltd undertakes within the specified period, to repair or replace free of charge, any part of the appliance found to be defective from a manufacturing fault provided that:
 - We are promptly informed of the defect.
 - The appliance has not been altered in any way or subjected to misuse or repair by a person other than a person authorised by Holmes Products (Europe) Ltd.
- Faults that occur through normal wear and tear are not covered by this guarantee.
- No rights are given under this guarantee to a person acquiring the appliance second hand or for commercial or communal uses.
- Any repaired or replaced appliance will be guaranteed on these terms for the remaining portion of the guarantee.

THIS PRODUCT IS MANUFACTURED TO COMPLY WITH THE E.E.C. DIRECTIVES 2006/95/EC, 2004/108/EC and 98/37/EEC.

Waste electrical products should not be disposed of with Household waste.

Please recycle where facilities exist.

Check on the following website for further recycling and WEEE information:

www.bionaire.com or e-mail
info-europe@jardencs.com



BIONAIRE®

Holmes Products (Europe) Ltd
1 Francis Grove
London SW19 4DT
England

Fax: +44 (0)20 8947 8272

Email: info-europe@jardencs.com

Website address: www.bionaire.com

UK - Filter Sales Order Line: 0870 759 9000

UK - Free phone Customer Service Helpline - 0800 052 3615

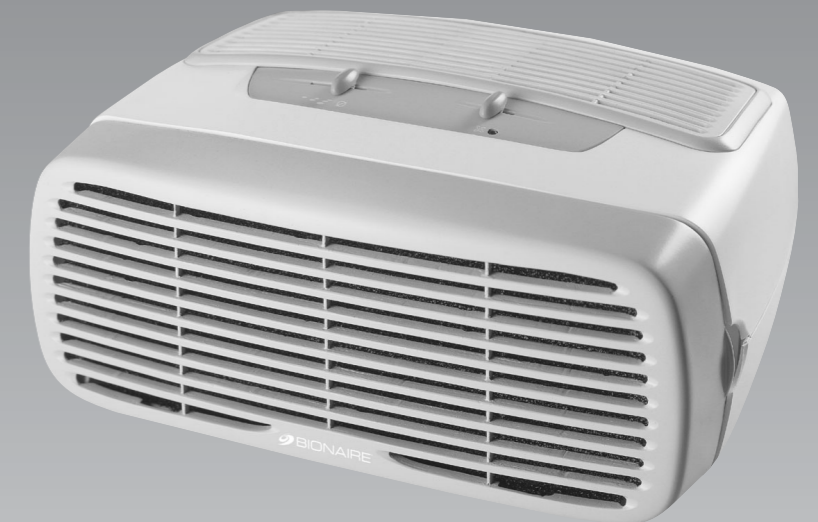

BIONAIRE®

Air Purifier

BAP242S



© 2007 Sunbeam Products, Inc. doing business as Jarden Consumer Solutions.
All Rights Reserved.

9100040003082
BAP242SIUK07EM1

INSTRUCTION MANUAL

Fig. 1

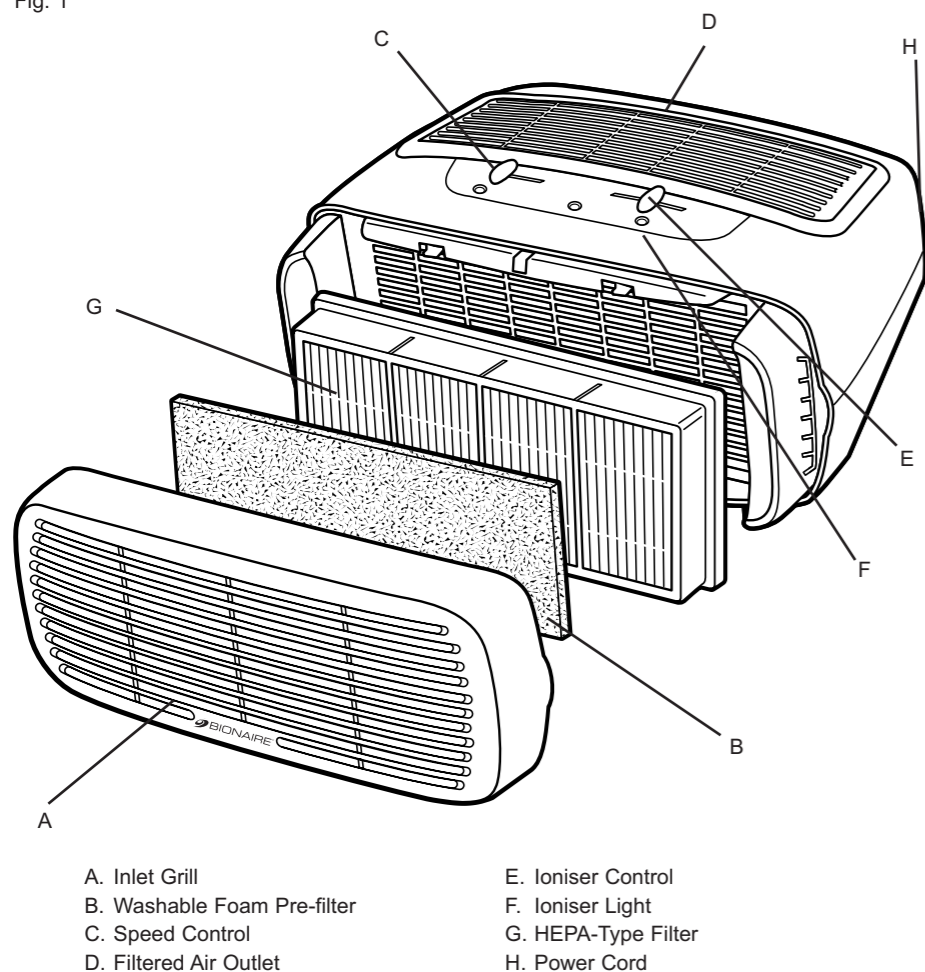
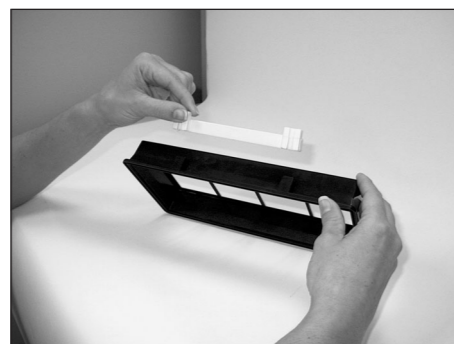

Fig. 2



Fig. 3



U.K. and IRELAND

PLEASE READ AND SAVE THESE IMPORTANT INSTRUCTIONS.

With proper care and use, this Bionaire® air purifier will give you fresh, clean air for many years.

NOTE: Before reading these instructions, please unfold the back page for the corresponding illustrations.

SAFETY PRECAUTION

Carefully read and retain all instructions before using the air purifier.

- To avoid fire or shock hazard, check that the voltage on the product corresponds to your electricity supply and plug directly into an electrical outlet.
- To avoid fire hazard, never put the cord under rugs, or near any heat source.
- Carefully discard any plastic wrapping that was used for the packaging.
- Do not use the air purifier outside.
- Do not place the unit near any heat source or in direct sunlight.
- Always unplug the air purifier before removing the grill, changing the filters, cleaning the air purifier or whenever it is not in use.
- Do not use in or around water or any other liquids. Do not attempt to wash the unit under running water.
- Use appliance only for intended household use as described in this manual.
- Ensure that all air openings are not restricted or covered in any way.
- Do not place anything on top of the unit.
- Never insert any object into any openings.
- Do not use the air purifier if any part is missing or damaged in any way.
- Do not attempt to repair or adjust any mechanical functions of this unit. If the unit becomes damaged return to the place of purchase or phone the helpline number on the back of this leaflet.
- If the supply cord or plug is damaged, it must be replaced by the manufacturer or its service agent or a similarly qualified person in order to avoid hazard.
- The air purifier contains no user serviceable parts and should the product suffer damage or breakdown it must be returned to the manufacturer or its service agent.
- Should the air purifier stop working, first check the fuse in the plug (UK only) or fuse/circuit breaker at the distribution board is operating, before contacting the manufacturer or service agent.

- This appliance is not intended for use by persons (including children) with reduced physical, sensory or mental capabilities, or lack of experience and knowledge, unless they have been given supervision or instruction concerning use of the appliance by a person responsible for their safety. Children should be supervised to ensure that they do not play with the appliance.

HOW THE AIR PURIFIER WORKS

Dirty, dust laden air is drawn through the front of the air purifier and through the multi-stage filtration system.

- The baking soda filter will help clear odours making the air cleaner and fresher.
- The HEPA filter entraps 99% of all smaller visible and non-visible particles down to 2 microns in size.

PRODUCT FEATURES

Quiet operation -

Your air purifier has been designed to be unobtrusive around the home and to be very quiet. The motor provides quiet performance and durability necessary for continuous use.

Dual position -

The unit can be placed either upright or on its side, flush against the wall. When positioning the unit be sure that the air inlet grill, filters and air outlet grill are not blocked, to ensure maximum air flow.

Ioniser -

Your Bionaire® Air Purifier has an independently controlled ioniser, which when turned on, releases negative ions into the outgoing filtered air. Ions are tiny particles that carry either a positive or negative charge. These ions exist naturally all around us in the air, water and ground. Both positive and negative ions are colourless, odourless and completely harmless. Negative ions help the air purification process by attaching themselves to very small airborne particles in the room. These particles take on a negative charge and may join with positively charged particles, such as dust, pollen, smoke and pet dander to form larger particles that are then more readily captured by the filter system, or they may be attracted to positively charged surfaces like walls or floors.

You may also note, after extended use, that dust may have collected around the grills or front panel. This is from the ionisation effect caused by the negative ions exiting from the air outlet. This dust does not come from the air output, but is drawn out of the uncleaned air going past the air outlet. This is additional evidence of the air cleaning effectiveness of negative ions. The dust can be easily removed with a clean, dampened cloth or soft brush.

PLEASE NOTE: it is important to change the HEPA filter at recommended intervals. Using the ioniser in conjunction with dirty filters may result in dirty particles exiting the air purifier and being attracted to walls, carpets, furniture and other household objects. These dirty particles may prove very difficult to remove.

PRE-OPERATING INSTRUCTIONS

- After removing the unit from the box, remove the plastic covering from the unit.
- Select a firm level place where there are no obstructions to the air inlet (front grill) or filtered air outlet (top of the unit)
- Remove the front grill by pulling the grill towards you (see Fig 2)
- Remove the HEPA filter by gripping on both sides and pulling forward.
- Remove protective plastic bag from the filter cartridge. The filter clip can only be attached to the hang tabs on the filter one way (see Fig 3). The filter clip should easily slide onto the filter hang tabs. Do not use force whilst attaching the filter clip to the filter. Align the clip on the top of your HEPA filter with the rails on the inside of the unit.
- Replace the front grill by sliding back on to the unit. Make sure that it snaps securely into position (the grill only goes on one way).

NOTE: The pleated material and rubber gasket should be facing towards the unit when applied.

NOTE: Do not point outlet towards wall.

OPERATING

- Plug into a suitable 220 – 240V electrical outlet.
- Select the required operating speed: Hi (III), Medium (II), Low (I) by sliding the switch to the appropriate setting.
- To release negative ions into the filtered air slide the ioniser button to ON. The amber light will illuminate.
- The ioniser will not work unless the unit is running.
- For optimum air filtration, it is recommended to operate the air purifier continuously. Its rugged motor is designed to give many years of service.
- For continuous use it is recommended to operate the air purifier at the medium (II) setting. For quieter operation or use in a bedroom, select the Low (I) setting. When high levels of air pollution are present, select the HI (III) setting to quickly circulate clean filtered air.

CLEANING AND MAINTENANCE

- Turn the air purifier off and unplug it before cleaning.
- The outside of the air purifier can be cleaned with a soft, clean dampened cloth.

- The filtered air outlet on the top of the unit can be cleaned of dust with a small, soft brush.
- If you wish to clean the inside of the air purifier, please only use a dry, soft cloth to wipe it down.

FILTER REPLACEMENT

IMPORTANT: IN ORDER TO RETAIN THE EFFICIENCY OF YOUR AIR PURIFIER, THE HEPA FILTER NEEDS TO BE CHANGED EVERY 3-6 MONTHS.

- Every few weeks check the condition of the prefilter.
 - Remove the front grill. If the foam pre-filter has collected a noticeable amount of dust, remove it from the inlet of the grill and wash it in warm soapy water. Rinse and dry the pre-filter thoroughly before replacing it in the inlet of the grill.
 - With the front grill removed, remove the HEPA cartridge and dispose in the dustbin. DO NOT try to wash and re-use the HEPA filter. Replace with a new HEPA filter - HAPF30 removing the protective plastic bag before inserting into the air purifier.
 - Align the clips on the top of your HEPA filter with the rails on the inside of the unit. Gently slide the filter onto the rails.
 - The filter clip should easily slide onto the filter hang tabs. Do not use force while attaching the filter clip to the filter. Align the clip on the top of your HEPA filter with the rails on the inside of the unit.
- NOTE:** The pleated material and rubber gasket should be facing towards the unit when applied.
- Replace the front grill by sliding back on to the unit. Make sure that it snaps securely into position (the grill only goes on one way).
- NOTE:** Do not point outlet towards wall.

REPLACEMENT FILTERS :

HAPF30 HEPA Filter

For UK only - Customer Service Helpline 0800 052 3615

Filter Sales Order Line - 0870 759 9000

SERVICE INSTRUCTIONS

- Do NOT attempt to repair or adjust any electrical or mechanical functions on this unit. Doing so will void the warranty. The insides of the unit contain no user serviceable parts. Only qualified personnel should perform all servicing.
- If you need to exchange the unit, please return it in its original carton, with a sales receipt, to the store where you purchased it.