

## THE POWERTAP SYSTEM

The PowerTap system includes a power-measuring hub which measures torque and wheel speed. This information is transmitted to a handlebar or stem mounted computer. The data is then integrated to display current, average, and maximum biometric information.

## PACKAGE CONTENTS

- 1x PowerTap Track hub
- 1x Lock ring
- 2x Axle bolts
- 1x User Guide

## COMPATIBILITY

- The PowerTap Track hub is compatible with White Industries splined cogs only.
- The PowerTap Track hub uses a 120mm bolt-on axle. Only insert the PowerTap Track hub into a frame designed with 120mm rear dropouts. Do not force the hub into any frame. Doing so may cause failure of the frame, hub, or both, and will void the warranty. Contact your dealer or Saris Cycling Group to address any special compatibility concerns.

## WHEEL BUILDING

Contact a wheel building professional or dealer for assistance in building the PowerTap Track hub into a wheel. Due to the design of the hub, the load pattern is not the same as a conventional hub. Slotting the hub flanges to accommodate bladed spokes is not recommended and will void the warranty. Complete wheel building hub dimensions are listed below. To determine proper spoke length, please reference a spoke length calculator.

## IMPORTANT:

**For your safety, the non-drive side of the PowerTap hub must be built with at least a 2x lacing pattern. Because of the patented PowerTap design, torque is transferred through the hub to the non-drive side. Failure to adhere to this precaution will void the warranty.**

Measurements	Non-drive	Drive
Hub center to flange:	21.5mm	28mm
Flange diameter:	70mm	70mm
Spoke hole diameter:	2.5mm	2.5mm
Hub spacing	120mm	

## INSTALLING THE COG

- Slide the cog onto the splined adapter.
- Install the lock ring. The lock ring is LEFT HAND THREADED.
- Use a standard Shimano Dura Ace bottom bracket wrench to tighten the lock ring to 25-30 Nm (18.5-22.1 ft-lb) torque.

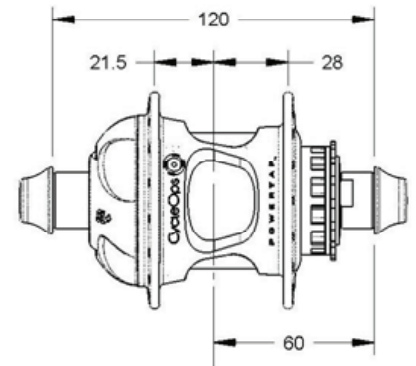
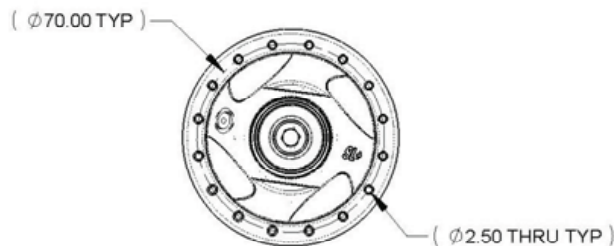

## AUTO-ZERO

In order for the PowerTap Track hub to accurately measure power, the Auto Zero function on the computer must be turned off.

### On Joule:

- Pair Joule to the PowerTap hub, as described in the Joule User Guide.
- Press [MODE] or [Interval] to turn on Joule.
- Press [MODE] until the Main menu screen is displayed.
- Press [JOYSTICK] to enter the Sensors menu.
- Press [JOYSTICK] to enter the Power Sensor menu.
- Use [JOYSTICK] to highlight the appropriate sensor and press [JOYSTICK] to select.
- In the sensor menu, scroll down to Auto Zero and press [JOYSTICK].
- Use [JOYSTICK] to change "Y" to "N". This turns the Auto Zero function off for this sensor. This only applies to this sensor, so this will not change any settings for other power meters.

### On Cervo:

- Pair Cervo to the PowerTap track hub, as described in the Cervo User Guide.
- Press and hold both [MODE] and [SELECT] buttons until you see the Set Edt 12345 screen.
- Press [SELECT] to scroll to "3" and then press [MODE] to enter
- Press [MODE] three times until "YES" is displayed on the bottom line
- Press [SELECT] to change to "no". This turns the Auto Zero function off. If/when you switch back to a normal PowerTap hub, make sure to change this back to "YES".

Note: Because the Auto Zero function is turned off, it is recommended to manually zero the hub on a regular basis.

## ANT+ Sport

The PowerTap "Plus" Series uses ANT+ Sport wireless technology that allows you to use the PowerTap with other ANT+ Sport devices that are capable of displaying power. If you are using a device other than CycleOps Joule or Cervo to display power, please consult the user guide that came with the device. Note: While the PowerTap Track hub sends an ANT+ signal, it is recommended by Saris Cycling Group to use a CycleOps Joule or Cervo for the purposes of using the manual zero function.

## MAINTENANCE & SPECIFICATIONS

During the course of repair, DO NOT remove the torque tube. There are no user serviceable parts inside. Special tools are required for assembly and calibration. If problems are suspected contact Saris Cycling Group.

### BEARINGS

The power measuring components inside the PowerTap hub are highly complex and should only be serviced by Saris Cycling Group. The bearings in the PowerTap hub do not require any adjustment. The bearings are sealed and do not require replacement. Field replacement can cause permanent damage to the power measuring electronics and result in compromised sealing and performance. If bearing problems are suspected please contact Saris Cycling Group.

TECHNICAL SPECIFICATIONS	
Accuracy	1.50%
Signal Transmission	2.4 GHz
Operational Temperature	0-40 C/32-104 F degrees
Battery Life	300 hours
Battery Type	#357/303 or EPX76 (2 per hub)-(IEC-SR44)

### HUB BATTERIES

Normal battery life for the hub batteries is 300 hours of actual ride time. Use #357/303 or EPX76 Silver oxide batteries (IEC-SR44) and always replace in pairs. Alkaline batteries have a shorter life and less performance.

### BATTERY REPLACEMENT

Use the battery cap removal tool (part# 7015) to unscrew the plastic cap on the non-drive side of the hub. Using the tool, unscrew the plastic battery cover to expose the battery holder and batteries.

### WARRANTY

The PowerTap hub is warranted to the original retail purchaser to be free from defects in materials and workmanship. Warranty coverage is valid to the original purchaser only and proof of purchase will be required. Electronics - 1 year

### THIS WARRANTY DOES NOT COVER:

- Normal wear and tear.
- Any damage, failure or loss caused by accident, misuse, neglect, abuse, improper assembly, improper maintenance, or failure to follow instructions or warnings in Owner's Manual.
- Use of products in a manner or environment for which they were not designed. This product was designed for use in a velodrome only.

### LIMITATIONS

The foregoing warranties are in lieu of and exclude all other warranties not expressly set forth herein, whether expressed or implied by operation of law or otherwise, including, but not limited to, warranties of merchantability or fitness for a particular purpose. Saris Cycling Group shall in no event be liable for incidental or consequential losses, damages or expenses in connection with its exercise products. Saris Cycling Group's liability hereunder is expressly limited to the replacement of goods not complying with this warranty or, at Saris Cycling Group election, to the repayment of an amount of the purchase price of the exercise product in question. Some states do not permit the exclusion or limitation of implied warranties or incidental or consequential damages, so the preceding limitations and exclusions may not apply to you.

### PROCEDURES

Warranty service will be performed by Saris Cycling Group or an authorized Saris Cycling Group Dealer. The original purchaser must provide proof of purchase. Service calls and/or transportation to and from the Authorized Saris Cycling Group Dealer are the responsibility of the purchaser.

- Saris Cycling Group will have the option to repair or replace any product(s) which requires warranty service.
- Saris Cycling Group will replace any unit that is structurally defective with a new unit or replace the unit with a unit of equal value.
- In the event a product cannot be repaired, Saris Cycling Group will apply a limited credit reimbursement toward another CycleOps PowerTap product of equal or greater value.

### DATA TRANSMISSION

The PowerTap hub transmits data on both the Saris network and ANT+ Sport simultaneously. Data transmitted on the Saris network:

- Applied power and torque
- Speed (angular velocity)
- Distance (wheel rotation)
- Cadence
- Hub battery condition

Data transmitted on the ANT+ Sport network

Power only message:

- Power
- Cadence

Torque at wheel message:

- Torque
- Speed
- Distance

## **COPYRIGHT**

Copyright 2008. All rights reserved. No part of this publication may be copied, photographed, reproduced, translated, transmitted electronically or placed on digital media without the prior written consent of Saris Cycling Group, Inc.

Saris Cycling Group, Inc.  
Model #: PowerTap SL2.4  
Contains IC:6459A-SL24TT1  
FCC ID:T8P-SL24TT1

## **TRADEMARKS**

Saris Cycling Group, Inc., PowerTap and the PowerTap logo, are all registered trademarks of Saris Cycling Group, Inc. All other product, brand, or trade names used in this manual may be trademarks or registered trademarks of their respective owners.

## **MODIFICATIONS**

Saris Cycling Group Inc, reserves the right to make improvements and/or updates to the products described herein at any time without notice.

## **FCC STATEMENT OF COMPLIANCE**

Statement of Compliance for FCC and Industry Canada:

"This device complies with Industry Canada and Part 15 of the FCC Rules. Operation is subject to the following two conditions: (1) This device may not cause harmful interference, and (2) this device must accept any interference received, including interference that may cause undesired operation."The term "IC:" before the radio certification number only signifies that Industry Canada technical specifications were met. Changes or modifications to this device not expressly approved by the party responsible for compliance with FCC regulations (the manufacturer) could void the user's authority to operate the equipment. This equipment has been tested and found to comply with the limits for a Class B digital device, pursuant to part 15 of the FCC Rules. These limits are designed to provide reasonable protection against harmful interference in a normal installation. This equipment generates, uses and can radiate radio frequency energy and, if not installed and used in accordance with the instructions, may cause harmful interference to radio communications. However, there is no guarantee that interference will not occur in a particular installation.