



INSTALLATION AND OPERATING INSTRUCTIONS

Cyclone SERIES

GAS CONVECTION OVENS

Models: BCO-G and GDCO-G

INTENDED FOR OTHER THAN HOUSEHOLD USE. RETAIN THIS MANUAL FOR FUTURE REFERENCE. OVEN MUST BE KEPT CLEAR OF COMBUSTIBLES AT ALL TIMES.

IMPORTANT INSTRUCTIONS: After the gas supply has been connected to your unit, it is extremely important to check piping for possible leaks. To do this, use soap and water solution or solutions that are expressly made for this purpose. **DO NOT USE** matches, candles, flames, or other sources of ignition since these methods are extremely dangerous. Instructions to be followed in the event you smell gas should be posted in a prominent location. Obtain these instructions from your local gas supplier.

FOR YOUR SAFETY



Do not store or use gasoline or other flammable vapors and liquids in the vicinity of this or any other appliance.



WARNING



Improper installation, adjustment, alteration, service or maintenance can cause property damage, injury or death. Read the Installation, Operating and Maintenance Instructions thoroughly before installing or servicing this equipment.



WARNING



Initial heating of oven may generate smoke or fumes and must be done in a well-ventilated area. Overexposure to smoke or fumes may cause nausea or dizziness.



This equipment has been engineered to provide you with year round dependable service when used according to the instructions in this manual and standard commercial kitchen practices.



BAKERS PRIDE OVEN CO., INC.

30 Pine Street
New Rochelle, NY 10801

Form # 8898500 4/05

+1 (800) 431-2745 US & Canada
+1 (914) 576-0200 Phone
+1 (914) 576-0605 Fax

sales@bakerspride.com E-Mail
www.bakerspride.com WebAddress

Table of Contents

I. INSTALLATION INSTRUCTIONS

SECTION	ITEM	PAGE
A	Receiving	2
B	Set Up / Mounting	3
C	Installation with Casters (Optional)	4
D	Location and Minimum Clearances	4
E	Gas Connections	4
F	Electrical Connection	5
G	Flue Connection Ventilation	5
H	Burner Operation	6
I	System Check Rotary Control	6
J	Programming Menus	6

II. OPERATING INSTRUCTIONS

A	General Instructions	7
B	Operation Sequence Rotary Control	7
	Cook only rotary control	7
	Timed cooking rotary control	7
	Cook and hold- rotary control	7
	Optional steam injection rotary control	8
	To cool down the oven quickly	8
C	Cleaning	8
D	Servicing	8
	Stacking Instructions	9
	Leg Assembly Instructions	10
	Wiring Diagrams	11, 12
	Parts List & Exploded View	13
	Warranty	16

I. INSTALLATION INSTRUCTIONS

A. RECEIVING

Read the notice on the outside carton regarding damage in transit. Damage discovered after opening the carton is "CONCEALED DAMAGE." Carrier must be notified immediately to send an inspector and to furnish forms for claims against the carrier.

When the oven arrives, it should consist of:

A crate or carton containing your new oven (two for a stacked unit).

A carton containing four 31" legs with mounting hardware (set of four 6" legs is supplied for stacked installations).

A carton containing a Flue Adapter and a Draft Hood. Optional: for Direct Venting (Not available for EuropeanCommunity Countries).

B. SET UP/MOUNTING:

NOTE:

This appliance must be installed by competent personnel in accordance with the rules in force.

In the U.K., Corgi registered installers (including the regions of British Gas) undertake to work to safe and satisfactory standards. This appliance must be installed in accordance with the current Gas Safety (Installation and Use) Regulations and the relevant Building Regulations/IEE Regulations. Detailed recommendations are contained in the British Standard Codes of Practice B.S. 6172, B.S. 5440: Part 2 and B.S. 6891.

Your oven will be packed sitting on its bottom. The skid may be left under the oven for convenience in further handling. Unpack carefully, avoiding damage to the Stainless Steel front and/or trim. If concealed damage is found, follow the instructions detailed in Section A (Receiving). Keep the area around the ovens free and clear of combustible materials. Do not store any materials on top of or under any oven. The provision for adequate air supply to your oven for ventilation and proper gas combustion is essential. As a minimum, observe the clearances detailed in Section D (Location). Provide adequate ventilation and make up air in accordance with local codes. Servicing your oven is done through the front control panel and right side access cover. Ensure that these areas are kept unobstructed for easy access.

For a single unit: Refer to Figure 4

- (1) Tilt Oven over to left-hand side and attach two 31" legs on the right-hand side with three 1/2" bolts and washers. Tighten firmly.
- (2) Using proper lifting equipment, lift up the left-hand side and attach two 31" legs on the left-hand side the same way.

For a stack of two ovens: Refer to Figure 3

- (1) Remove flue from bottom oven prior to stacking. When top oven is properly positioned on bottom oven, re-install the flue back on the bottom oven.
- (2) Tilt lower unit over to the left-hand side and position two 6" legs on the right side (one for front and one for back), secure in place by using 4 bolts (3/8"-16) per leg. Tighten firmly.
- (3) Using proper lifting equipment, lift up the left side of the unit and attach the other two legs in the same way.
- (4) Using the lifting equipment, raise the top oven to proper height and slide on top of the bottom oven. Line up sides and front and fasten to each other at the rear of the units by using a mounting bracket supplied in the stacking kit.

To assemble an open rack stand: Refer to Figure 1

- (1) Loosen 12 bolts (attaching 31" legs) slightly.
- (2) Remove 4 inner bolts, 1 from each of the 4 legs, place top right angle and top left angle underneath and tighten these 4 bolts.
- (3) Insert "Open Rack Shelf" and tighten into place with eight 3/8-16 screws, washers and nuts.
- (4) Position "Rack Supports" and tighten in place using 4 each of flat washers and 5/16-18 Hex Nuts.

Figure 1 OPEN RACK STAND ASSEMBLY INSTRUCTIONS: BCO-E & GDCO-E

STEP 1) Attach 4 each Item 2 with 16 each 3/8 -16 bolts to the threaded holes located in the bottom of the oven or supplied with leg kit.

STEP 2) Place Item 4 between the legs and over Item 9 then attach Item 9 to Item 4 with 16 each 10-32 screws.

STEP 3) Attach Item 5 to Item 10 using 2 each 1/4 -20 screws (Both sides)

STEP 4) Place Item 5 into Item 6 and into the holes in Item 4. (Both sides)

CAUTION
Do not store combustible items or materials on racks.

Fit the Standard Flue Diverter supplied into the hole in the top of the oven for under ventilation hood installation and secure with screws. For direct venting, Flue Adapter and Draft Hood must be placed into the hole on top of the oven.

C. INSTALLATION WITH CASTERS (OPTIONAL): Refer to Figure 4

Four casters (two with wheel brakes) and the mounting hardware are packed and included in the shipment if ordered. Install casters with wheel brakes on the front of the unit. Installation of the unit should be made with a connector that complies with the latest edition of the Standard for Connectors for Movable Gas Appliances ANSI Z21.69 in the USA (CAN CSA-6.16 in Canada) and a quick-disconnect device that complies with the latest edition of the standard for quick disconnect devices for use with gas fuel ANSI Z21.41 in the USA (CSA 6.9 in Canada). Adequate means must be provided to limit the movement of the appliance without depending on the connector and any quick disconnect device or its associated piping to limit appliance movement.

The restraint should be attached to the rear legs of the oven on which casters are mounted. If disconnect of the restraint is necessary, the restraint should be immediately reconnected after the appliance has been returned to its originally installed position.

D. LOCATION AND MINIMUM CLEARANCES:

Move the oven to its final location keeping the minimum clearance from the back of the oven to the wall. This clearance is necessary for safe operation and to provide proper air flow to the burner chamber.

MINIMUM CLEARANCES FROM COMBUSTIBLE AND NONCOMBUSTIBLE CONSTRUCTION		
	Under Ventilation Hood	Direct Venting
RIGHT WALL	1"	1"
LEFT WALL	1"	3"
REAR WALL	3"	3"

 SUITABLE FOR INSTALLATION ON COMBUSTIBLE FLOOR WHEN INSTALLED WITH LEGS OR CASTERS PROVIDED.
 

 CAUTION: DO NOT SET THE OVEN WITH ITS BACK FLAT AGAINST THE WALL. IT WILL NOT OPERATE PROPERLY UNLESS THERE IS AT LEAST THREE INCHES BREATHING SPACE BEHIND THE OVEN
 

E. GAS CONNECTION:

The ovens should not be installed on the same gas supply line with space heaters, boilers or other gas equipment with high intermittent demand.

The installation of the oven must conform to the latest local codes or *National Fuel Gas Code, ANSI Z223.1, Natural Gas Installation Code, CAN/CGA-B149.1, or the Propane Installation Code, CAN/CGA-B149.2.*

The appliance must be isolated from the gas supply piping system by closing its manual shut-off valve during any pressure testing of the gas supply piping system at test pressures equal to or less than ½ psig (3.45kpa). The appliance and its shut-off valve must be disconnected from the gas supply piping system during any pressure testing of that system at test pressures in excess of ½ psig (3.45kpa).

Use a pipe joint compound that is resistant to the action of liquefied petroleum gases when making gas connections. For Propane gas, use at least ½" (13 mm) pipe or tubing with a 5/8" (16 mm) inside diameter. For Natural gas, use ¾" (19 mm) pipe.

The gas pressure regulator is part of the combination valve and is adjusted to yield a pressure of 3.5" water column (9 mbar) for Natural Gas. If the oven is ordered for use on Propane Gas or Butane, the pressure regulator in the combination valve is preset at the factory to yield a pressure of 10" water column (25 mbar). **NOTE: No external regulator is required.**

Gas supply pressure in the European Community countries should be as below.

Gas Type	Supply Pressure
G20	20 mbar
G25	25 mbar
G20/25	20/25mbar
G30	30 or 50 mbar depending on country
G31	30, 37, or 50mbar depending on country

A separate shut-off valve for each oven must be provided. It should be as close as possible to the place where the gas line goes into the oven. It must be located such that it is easily accessible. When stacking with another oven, two shut-off valves, one for each of the two ovens, must be provided.

After the Gas Supply has been connected, it is extremely important to check all the piping for leaks. Use a soap and water solution or a product expressly made for this purpose. Do not use matches, candles or a flame and so forth to check leaks since these methods are extremely dangerous.

F. ELECTRICAL CONNECTION:

The oven, when installed, must be electrically grounded in accordance with local codes and/or the latest edition of the National Electrical Code ANSI/NFPA No. 70 in the USA (Canadian Electrical Code CSA Standard C22.1, Part 1 in Canada).

In Europe, the appliance must be connected by an earthen cable to all other units in the complete installation and, thence, to an independent earth connection in compliance with EN 60335-1 and/or local codes.

The electric motor, all the related switches, interior lights, and the timer/buzzer are all connected through the 6-foot (1829 mm) power supply cord located at the rear of the oven. The supply cord must be plugged into a properly grounded, three-prong receptacle. **DO NOT CUT OR REMOVE THE GROUNDING PRONG FROM THE PLUG.**

Normal factory connections are made for 120 volts A.C., 60 hz, Service in USA and Canada or 240 volts A.C., 50 hz service in European community countries. Other voltages can be supplied upon request. Electrical characteristics of this unit can be found on the rating plate located on the right side of the unit.

This unit is provided with a permanently lubricated electric motor. A wiring diagram may be found on the back of the service panel on the right-hand side and in this manual.

G. FLUE CONNECTION VENTILATION:

Installation under ventilation hood (standard):

If the oven is not vented directly and is installed under a ventilation hood, the unit is ready to be installed as is. Local inspectors and ventilation specialists should be consulted so that the design and the installation of the hood conform to local/municipal codes. In the U.K., follow ventilation requirements as detailed in B.S. 5440.

Optional direct venting (not available for European community countries):

If direct venting, a flue adapter and a draft hood are required to be installed. They prevent the flue gases leaving the oven to be affected by the air pressure changes on the outside of the flue stack extending out of the building. The flue pipe from the draft hood must not run downwards at any point from the oven to the final outlet. It should always slant slightly upwards. For best results, it should rise straight up. The venting system shall be in accordance with the National Fuel Gas Code, ANSI Z223.1 / NFPA 54 and or the CSA B149.1, Natural Gas and CSA B149.2, Propane Installation Codes, and local codes.

NOTE: DO NOT PUT A DAMPER IN THE FLUE AND DO NOT CONNECT A BLOWER DIRECTLY TO THE FLUE.

If the flue runs directly to the free air outside the building, use a wind deflector or a UL listed vent cap at the end of the pipe. Termination of the vent must be at least two feet above the highest part of the roof within ten feet. REF: AGACATALOG NO. XH0474.

H. BURNER OPERATION:

The oven burner flame should always have a blue appearance. This indicates a good mixture of air and gas. When using LP gas, the flame will have a blue-yellow appearance. There may be intermittent yellow-orange flame noticed. This is caused by dust particles burning in the flame.

I. SYSTEM CHECK- ROTARY CONTROL:

- (1) Open the oven door.
- (2) Turn Selector Switch to "HI." The indicator light near Selector Switch and oven light will illuminate.
- (3) Close the door. Oven lights will go off and fan will run. Make sure fan is rotating clockwise looking from front.
- (4) Press Oven Light switch. Oven light will go on and will go off when switch is released.
- (5) Turn Gas Cock Dial to "ON" position (only for USA and Canada).
- (6) Turn the thermostat knob. The indicator light near the thermostat will illuminate and the burners will come on.
- (7) Turn the Timer Knob and set a time of 2 minutes. At the end of 2 minutes, you should hear the buzzer. Turn the timer knob to "0", to stop the buzzer.
- (8) Open the oven doors. Oven lights will go on and burners and fan will go off.
- (9) Turn Selector Switch to "Cool Down" position. The fan will run to cool down the oven.
- (10) Turn Selector Switch to "0" position.
- (11) Close the oven doors.

NOTE: OVEN STARTS HEATING AS SOON AS THE SET TEMPERATURE IS HIGHER THAN THE OVEN TEMPERATURE WITH THE OVEN DOORS CLOSED AND THE SELECTOR SWITCH NOT IN "0" POSITION.

THERMOSTAT INDICATOR LIGHT GOES OUT WHEN OVEN REACHES SET TEMPERATURE AND COMES ON WHEN OVEN IS HEATING UP.

IN THE EVENT OF POWER FAILURE, THE OVEN WILL NOT OPERATE. RESTORATION OF POWER AFTER ANY DURATION, WILL RETURN UNIT TO NORMAL OPERATION.

J. PROGRAMMING MENUS (for units with digital controls):

Refer to C&H - 3 Plus Controller Operating/Programming Instructions Manual.

II. OPERATING INSTRUCTIONS

A. GENERAL INSTRUCTIONS:

- (1) This equipment has an Electronic Temperature Control and Electronic Hot Surface Direct Ignition System.
- (2) Due to increased efficiency of this oven, the temperature of standard recipes may be reduced 50°F (30°C).
- (3) Always load each shelf evenly. Space pans away from each other and from sides and back of oven to allow maximum air flow between them.
- (4) Large tempered glass windows and interior lights allow a close check on the product, making it unnecessary to frequently open the doors. Products cook faster in a convection oven as compared to a conventional oven. Depending on the product and the type of pans used, time saving may run from 20 percent to as high as 50 percent.

B. OPERATION SEQUENCE ROTARY CONTROL:

Cook only rotary control:

- (1) Close the oven doors.
- (2) Turn Selector Switch to "HI" or "LO" position. The indicator light near the Selector Switch will be illuminated.
- (3) Turn the thermostat knob to the desired cooking temperature.
- (4) Upon reaching the set temperature, the indicator light near the thermostat will go out.
- (5) Load the oven with product to be cooked.
- (6) Remove the product from the oven when done.

Timed cooking rotary control:

- (1) Close the oven doors.
- (2) Turn Selector Switch to "HI" or "LO" position. The indicator light near the Selector Switch will be illuminated.
- (3) Turn the thermostat knob to the desired cooking temperature.
- (4) Upon reaching the set temperature, the indicator light near the thermostat will go out.
- (5) Load the oven with product to be cooked.
- (6) Turn the timer knob to the desired bake time and timer will start counting down.
- (7) When timer reaches zero, a buzzer will sound.
- (8) Turn the timer knob to "O" position.
- (9) Remove the product from the oven.

NOTE: TIMER IS A SIGNAL DEVICE ONLY AND DOES NOT CONTROL THE OVEN.

Cook and Hold Rotary Control:

- (1) Close the oven doors.
- (2) Turn Selector Switch to "HI" or "LO" position. The indicator light near the Selector Switch will be illuminated.
- (3) Turn the thermostat knob to the desired cooking temperature.
- (4) Upon reaching the set temperature, the indicator light near the thermostat will go out.
- (5) Load the oven with product to be cooked.
- (6) Turn the timer knob to the desired bake time and timer will start counting down.
- (7) When timer reaches zero, a buzzer will sound.
- (8) Turn the Timer knob to "O" position.
- (9) Turn the thermostat knob to the desired hold temperature.
- (10) Remove the product from the oven when needed.

Optional steam injection: Rotary control:

The solenoid valve for steam injection is mounted behind the service panel on the right-hand side of the unit. The electronic timer is preset at the factory. A ¼" copper tubing is provided on the Solenoid Valve for water hookup with a compression fitting. After the water hookup is made, make sure that there are no leaks. For steam injection, press the Steam switch momentarily.

NOTE: DO NOT USE STEAM INJECTION AT TEMPERATURES BELOW 275°F (135°C).

Oven cool down Rotary control:

To cool down the oven to a lower desired temperature, follow the steps detailed below.

- (1) Open the oven doors.
- (2) Turn Selector Switch to "oven cool down" position. Fan will now operate and cool down the oven.
- (3) When the oven has cooled down to the desired temperature, turn the Selector Switch to "O" position. Close oven doors.

C. CLEANING:

CLEAN ONLY WHEN OVEN IS COLD

- (1) With porcelain enamel interiors, this oven is designed to be as maintenance free as possible. However, for best results, the oven should be cleaned regularly. Enameled interiors can be easily cleaned with oven cleaners. **KEEP CLEANING FLUIDS AWAY FROM ELECTRICAL WIRES, LIGHT SOCKETS, SWITCHES AND CONTROL PANEL.**
- (2) Baked on splatter, oil, grease or discoloration on the stainless steel front or inside of the oven may be removed with the stainless steel cleaner supplied or any other similar cleaning agent. **NOTE: ALWAYS RUB THE STAINLESS STEEL ALONG THE GRAINS.**
- (3) To clean the blower wheel, remove and immerse in ammoniated water for 20 to 25 minutes. Then, scrub it off with a small, stiff brush. The same procedure can be followed for wire racks and rack supports. To remove the blower wheel, loosen the set screws (2) on the hub of the blower wheel and tighten the 3/8" wheel puller bolt (supplied) in center of the hub (See Figure 2).

D. SERVICING:

NOTE: THIS APPLIANCE MUST BE SERVICED BY AN AUTHORIZED SERVICE AGENT.

- (1) Power supply to the unit must be disconnected before any service is performed.
- (2) Most of the service on the unit can be performed from the front and/or control panel side.
- (3) For proper servicing, access to the control panel side of the unit will be required.
- (4) It will be necessary to have access to the back of the oven for service needs related to the gas supply and electric power supply.
- (5) A system wiring diagram is provided in this manual and on the back of the service panel on the right side of the oven.
- (6) This unit is provided with a permanently lubricated electric motor.
- (7) All servicing should be performed by a factory-authorized technician only.
- (8) For proper maintenance and repairs, call the factory toll free (800-431-2745) for an authorized service agency in your area.

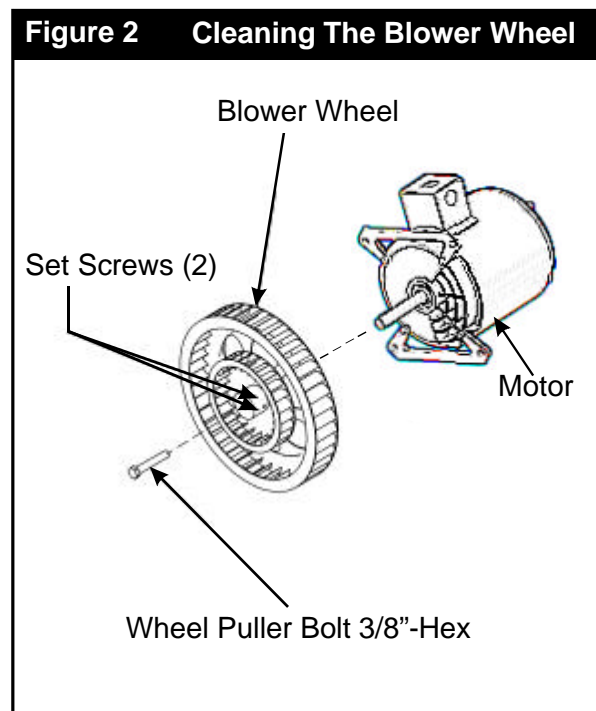

NOTE: THE VENTILATION SYSTEM MUST BE INSPECTED AT LEAST EVERY SIX MONTHS AND MAINTAINED CLEAN AND FREE OF OBSTRUCTIONS.

Figure 3 STACKING INSTRUCTIONS FOR: BCO-G & GDCO-G CONVECTION OVENS

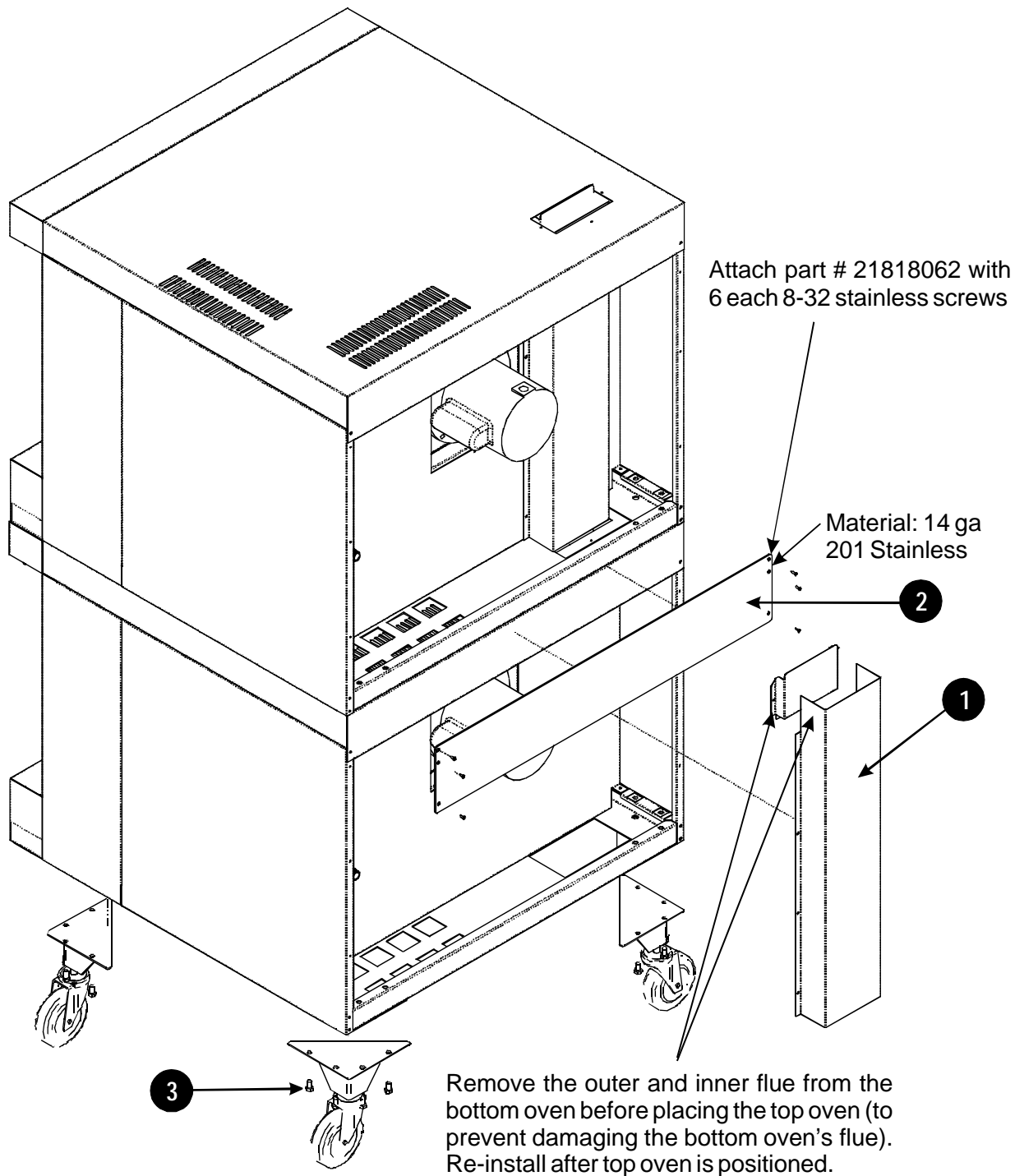

Item 1	Item 2	Item 3
 <p>E3770A</p>	 <p>E3771A</p>	 <p>3/8"-16 Bolt</p>

Figure 4

LEG ASSEMBLY INSTRUCTIONS-MODEL: BCO-G & GDCO-G

WITH PLATE CASTER

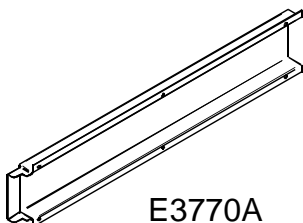
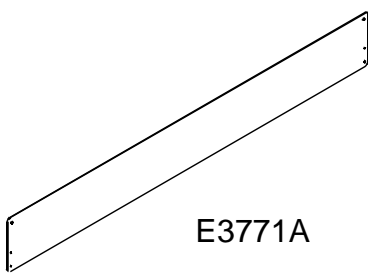
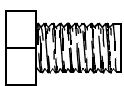
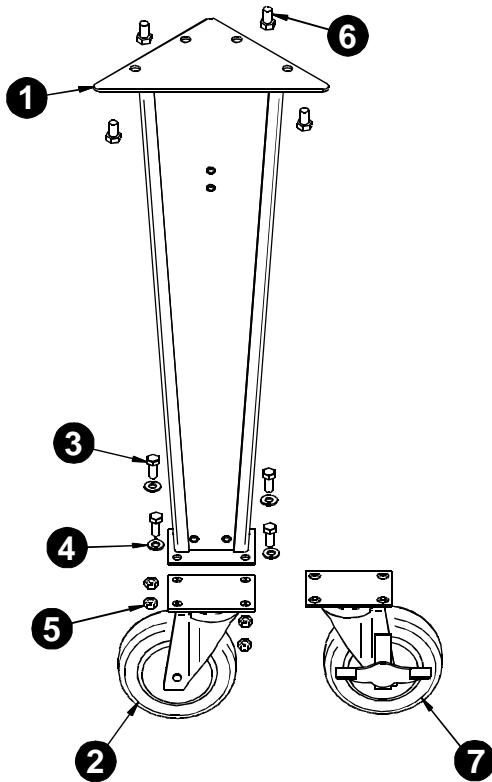

Item	P/N	Description
1	21818092	Leg, 25" SS Weldment Assy
2	8633102	Caster, 5" Swivel W/Top Plate
3	8227700	Hex Hd 5/16-18 X 3/4 Bolt #5 Zn
4	8509300	Washer, Flat SAE, 5/16
5	8435000	Hex-nut 5/16-18
6	82447-00	Hex Hd. 3/8-16 X .750 #5
7	8633101	Caster, 5" Swivel W/Plate & Brake

1. Attach two item 2 to two item 1 using item 3, 4 and 5.
2. Attach two item 7 to two item 1 using item 3, 4 and 5.
3. Using proper lifting equipment attach item 1 to the 4 corresponding hole patterns located in the bottom of the oven with item 6.

WITHOUT PLATE CASTER

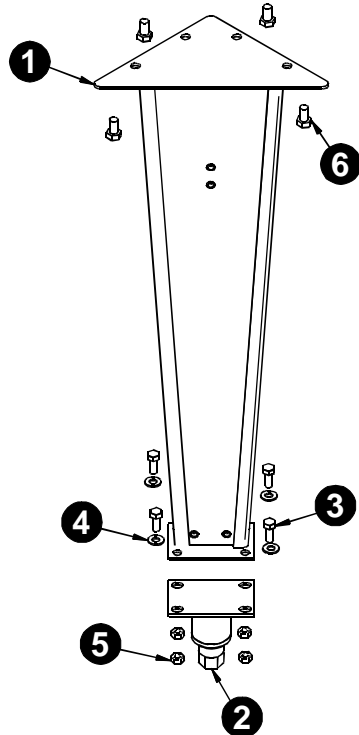

Item	P/N	Description
1	21818095	Leg, 25" Weldment Assy
2	8633515	Foot Insert, Adjustable
3	8227700	Hex Hd 5/16-18 X 3/4 Bolt #5 Zn
4	8509300	Washer, Flat, SAE, 5/16
5	8435000	Hex-Nut 5/16-18
6	82447-00	Hex Hd. 3/8-16 X .750 #5

1. Attach two item 2 to two item 1 using item 3, 4 and 5.
2. Using proper lifting equipment attach item 1 to the 4 corresponding hole patterns located in the bottom of the oven with item 6.

SINGLE-PHASE 120V WIRING DIAGRAM (PUSH-BUTTON CONTROL)

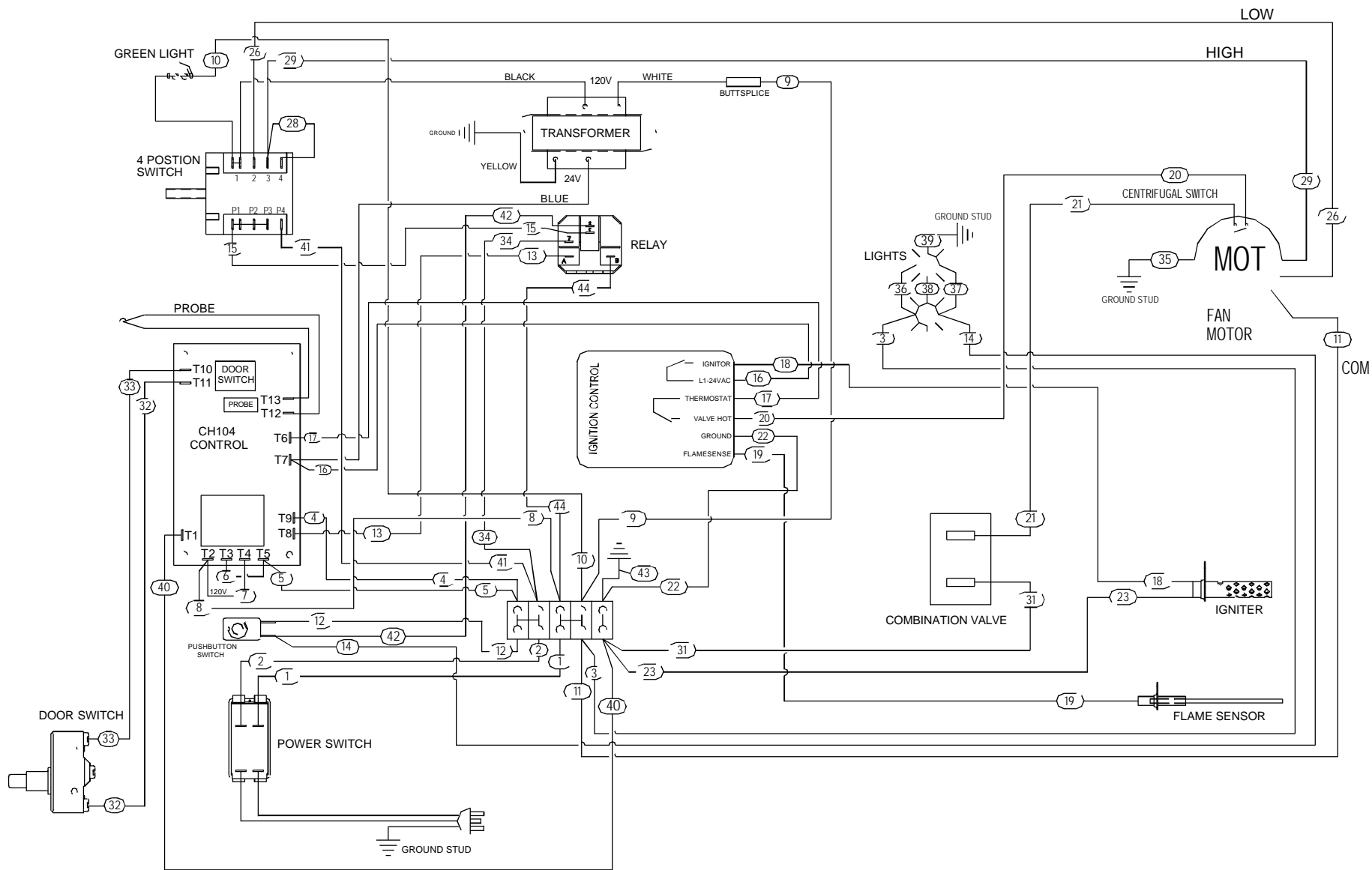

SINGLE-PHASE 120V WIRING DIAGRAM (DIAL CONTROL)

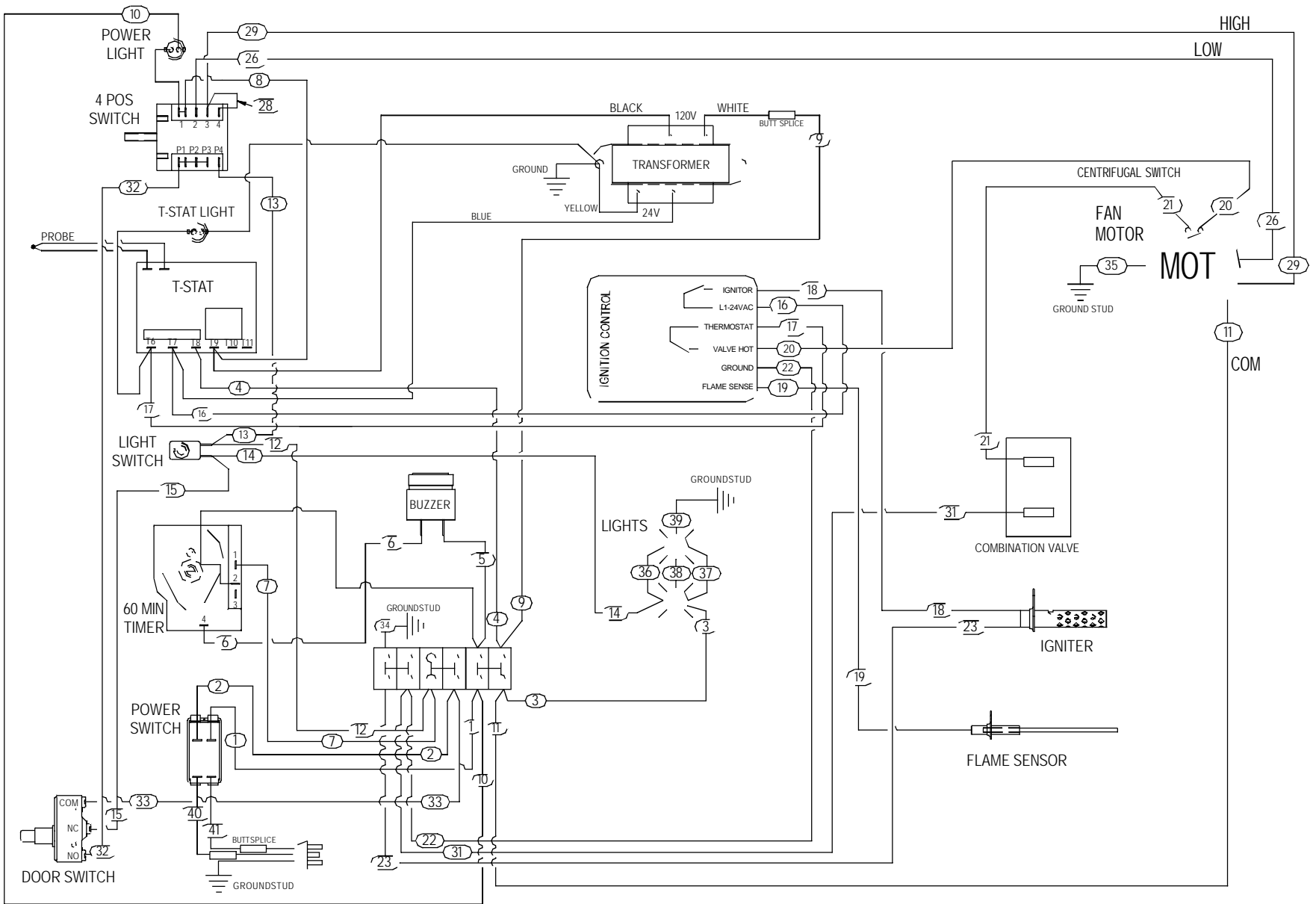



30 Pine Street • New Rochelle • New York • 10801

914 / 576 - 0200

914 / 576 - 0605

1 - 800 - 431 - 2745

www.bakerspride.com

fax

US & Canada

web address

BCO-G & GDCO-G

Full Size Gas Convection Oven

PARTS LIST

Cyclone

SERIES



Model Number: **BCO-G & GDCO-G**

Type of Gas: Natural

L.P.

Other

Serial Number: _____

Voltage/Phase: 115/1

208-240/1

230/1 (CE)

(Not Shown)

Exterior / Interior / Controls / Doors

Part #	Description
E8752A	KIT, 25" LEGS BLACK w/3" ADJ FEET
E8753A	KIT, 25" LEGS BLACK w/PLATE CASTER
E8754A	KIT, 25" LEGS S/S w/3" ADJ FEET
E8755A	KIT, 25" LEGS S/S w/PLATE CASTERS
E8756A	KIT, STACKING w/6" ADJ LEGS
E8759A	KIT, STACKING w/PLATE CASTER
T8097A	KIT, UNDERSHELF
T8026A	KIT, OPEN RACK STAND
E8765A	KIT, CONVERSION TO LP
E8766A	KIT, CONVERSION TO NAT

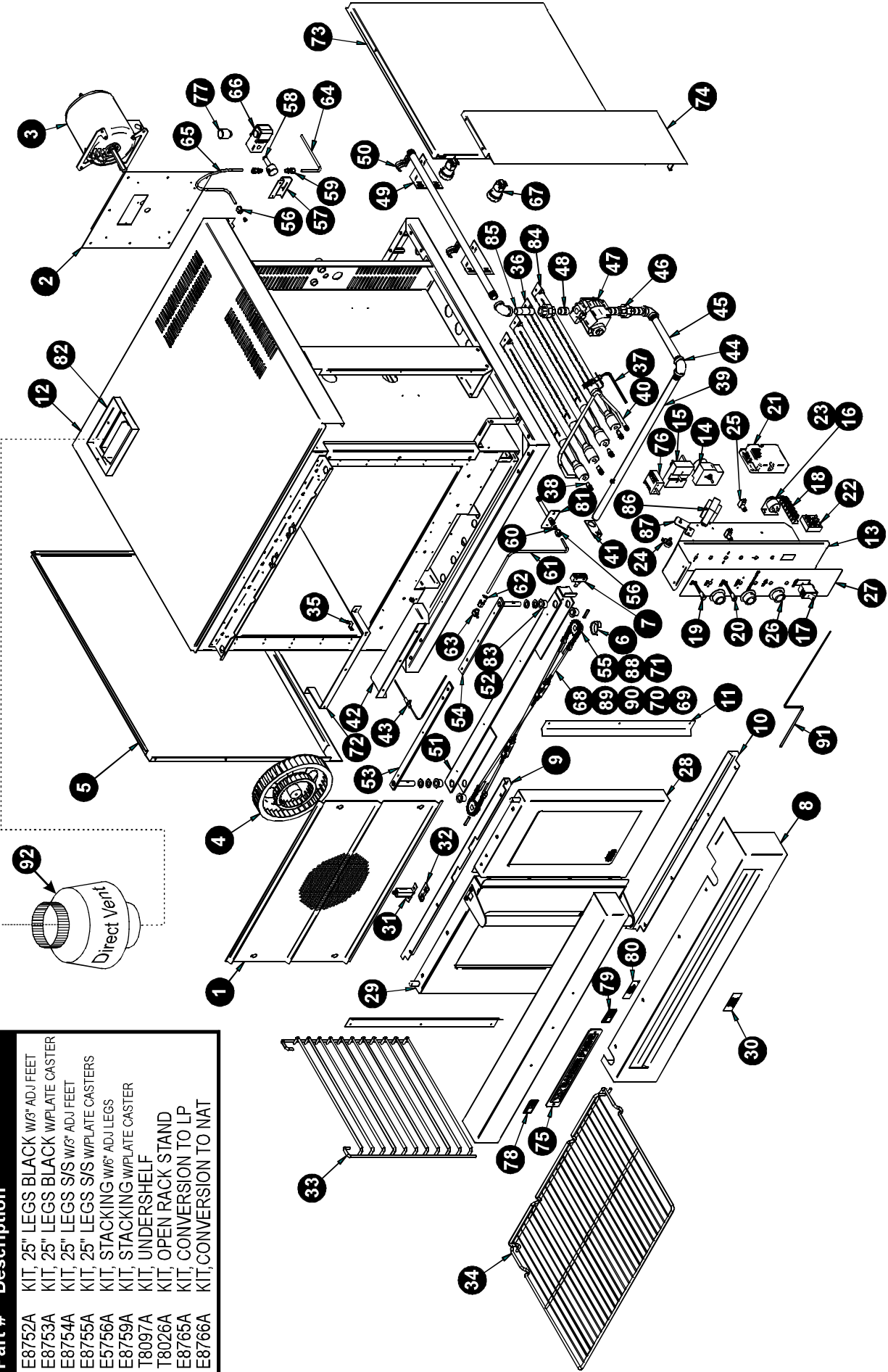

Note: When ordering, ALWAYS specify Part #, Model #, Serial #, Voltage/Phase & type of Gas.

Item	Part #	Description	Quan	Item	Part #	Description	Quan
1	E8189A	BAFFLE PLATE	1	47	R3164A	VALVE, COMBINATION (NAT.)	1
2	E8138A	MOTOR MOUNT	1		R3165A	VALVE, COMBINATION (L.P.)	1
3	M9208A	MOTOR 115V 850/1725 RPM	1	48	N5019A	NIPPLE, 1/2" X 1-1/8" STEEL PIPE	3
4	S1195A	BLOWER WHEEL	1	49	E8188A	BRACKET, SUPPORT	1
5	E8160A	PANEL, LEFT OUTER	1	50	P9900A	CLIP JIFFY 1/2"	2
6	S6810A	CAM, SWITCH	1	51	E8144A	BOTTOM CHANNEL	6
7	M1102A	SWITCH, DOOR	1	52	S0420A	THRUST BEARING	4
8	E8170A	BOTTOM TRIM	1	53	S6819A	ARM, 60 WELDMENT	4
9	E8178A	SEAL, TOP	1	54	S6821A	ARM, 40 WELDMENT	1
10	E8177A	SEAL, BOTTOM DOOR	1	55	S6805A	SPROCKET, DOOR	2
11	E8176A	SEAL (BETWEEN LEFT & RIGHT DOOR)	2	56	N7103A	FITTING, NUT S/S COMP 1/4 TUBE (STEAM OPTION ONLY)	2
12	E8156A	PANEL, TOP OUTER	1	57	E8778A	BRACKET, MOUNTING (STEAM OPTION ONLY)	1
13	E8193A	CONTROL PANEL ASSY.	1	58	M1114A	SOLENOID VALVE, 1/8 X 1/8 (STEAM OPTION ONLY)	1
14	M1332A	TIMER, 60 MINUTE	1	59	N3041A	FITTING 1/4 COMP X 1/8 MPT (STEAM OPTION ONLY)	2
15	M0110A	THERMOSTAT, FASTRON G6	1	60	N5815A	FITTING, 1/4" Tube Sleeve S/S FERRULE (STEAM OPTION ONLY)	2
16	E6895A	BRACKET, BUZZER	1	61	N8788A	STEAM TUBE (STEAM OPTION ONLY)	1
17	M1352A	SWITCH, ROCKER	1	62	N3041A	FITTING, FEM SS COMP 1/4 TUBE TO 1/8 PIPE (STEAM OPTION ONLY)	1
18	P7200A	TERMINAL BLOCK	1	63	N1019A	STEAM INJECTION NOZZLE (STEAM OPTION ONLY)	1
19	P9600A	PILOT LIGHT GREEN (POWER)	1	64	N8789A	TUBE, SUPPLY (STEAM OPTION ONLY)	1
20	P1167A	LIGHT, INDICATOR 250V, AMBER	1	65	N8791A	TUBE, VALVE TO OVEN (STEAM OPTION ONLY)	1
21	M2138A	IGNITION MODULE	1	66	M1115A	SOLENOID COIL 120/240 V, 17/12 W, 50/60Hz (STEAM OPTION ONLY)	1
22	M1175A	TIMER, SOLID STATE, 120 VAC, 5-60 SEC (STEAM OPTION ONLY)	1	67	P1144A	SNAP IN LIGHT ASSY 130V/15W	2
23	M1335A	AUDIO ALARM	1	68	S6816A	EYE HOOK, SHORT	2
24	M1176A	POTENTIOMETER (STEAM OPTION ONLY)	1	69	S6814A	EYE HOOK, LONG	2
25	M1049A	SWITCH, PUSH BUTTON (2 EA - STEAM OPTION ONLY)	1	70	S0410A	TURNBUCKLE, 1/4-20	2
26	S1311A	KNOB	3	71	Q4033A	ROLL PIN, 250 X 1,250	2
27	U8054A	DECAL BASIC BLUE & GOLD	1	72	E8125A	BRACKET WELDMENT	1
28	E6825A	DOOR, 40 W WINDOW ASSY	1	73	E8159A	PANEL, RIGHT OUTER	1
29	E6827A	DOOR, 60 W WINDOW ASSY	1	74	S8159A	PANEL, INSERT CONTROL	1
30	U4198A	DECAL, LEG	1	75	U1043A	NAME PLATE	1
31	S8768A	CATCH, ROLLER ADJUSTABLE	1	76	M1326A	SWITCH, 4 POSITION ROTARY	1
32	S8019A	PLATE, STRIKER	1	77	P1900A	CONNECTOR, 1/2" FLEX STRAIGHT	4
33	T3044A	SUPPORT, WIRE RACK	2	78	U3149A	LABEL, WARNING HOT SURFACE (FRENCH)	1
34	T3043A	RACK, FULL SIZE	5	79	U3103A	LABEL, WARNING, HOT SURFACE	1
35	E6865A	SUPPORT, SIDE RACK	8	80	U4197A	DECAL, CAUTION DISCONNECT	1
36	L5091A	BURNER w/IGNITOR BRACKET	1	81	E8790A	WELDMENT, WALL TUBE MOUNT	1
37	M2140A	IGNITER 24 V	1	82	E8064K	ADAPTER, VENT (DIRECT VENTING ONLY)	1
38	R3180A	ORIFICE #48 NAT ONLY	4	83	S0430A	FLANGE BEARING	1
	R6756A	ORIFICE 1.25MM LP ONLY	4	84	L5090A	BURNER	3
39	R8118A	MANIFOLD	1	85	N5007A	NIPPLE, 1/2" X 2-1/2" STEEL PIPE BLACK	1
40	R3161A	CARRY OVER, PILOT ORIFICE #71 (NAT)	1	86	M1360A	TRANSFORMER, CLASS 2, 120/240V-24V, 40VA	1
41	E8187A	BRACKET MANIFOLD	1	87	E8779A	BRACKET, MOUNTING (POTENTIOMETER)	1
42	E8143A	PANEL, FRONT FIREBOX	1	88	S6804A	CHAIN, ROLLER #35	2
43	M1323X	FLAME SENSOR	1	89	Q2039A	NUT, HEX, LEFT HAND 1/4-20 SS	2
44	N3010A	ELBOW, 1/2" X 90°	3	90	Q2016A	NUT, HEX, 1/4-20 SS	2
45	N5024A	NIPPLE, 1/2" X 8"	1	91	M0120A	PROBE, RTD	1
46	N3009A	UNION, 1/2"	2	92	R3002Y	DIRECT VENT	1

Note: When ordering, ALWAYS specify Part #, Model #, Serial #, Voltage/Phase & type of Gas.



BAKERS PRIDE LIMITED WARRANTY

30 Pine Street New Rochelle, New York 10801
914 / 576 - 0200 • US & Canada: 1 - 800 - 431 - 2745 • fax 914 / 576 - 0605

- WHAT IS COVERED** This warranty covers defects in material and workmanship under normal use, and applies only to the original purchaser providing that:
- ◆ The equipment has not been accidentally or intentionally damaged, altered or misused;
 - ◆ The equipment is properly installed, adjusted, operated and maintained in accordance with National and local codes, and in accordance with the installation instruction provided with the product;
 - ◆ The serial number rating plate affixed to the equipment has not been defaced or removed.
- WHO IS COVERED** This warranty is extended to the original purchaser and applies only to equipment purchased for use in the U.S.A.
- COVERAGE PERIOD** Cyclone Convection Ovens: BCO Models: One (1) Year limited parts and labor; (1) Year limited door warranty.
GDCO Models: Two (2) Year limited parts and labor; (2) Year limited door warranty.
CO11 Models: Two (2) Year limited parts and labor; (5) Year limited door warranty.
All Other Products: One (1) Year limited parts and labor. Warranty period begins the date of dealer invoice to customer or ninety (90) days after shipment date from BAKERS PRIDE - whichever comes first.
- WARRANTY COVERAGE** This warranty covers on-site labor, parts and reasonable travel time and travel expenses of the authorized service representative up to (100) miles, round trip, and (2) hours travel time. The purchaser, however, shall be responsible for all expenses related to travel, including time, mileage and shipping expenses on smaller counter models that may be carried into a Factory Authorized Service Center, including the following models: PX-14, PX-16, P18, P22S, P24S, PD-4, PDC, WS Series and BK-18.
- EXCEPTIONS** All removable parts in BAKERS PRIDE Char-broilers, including but not limited to: Burners, Grates, Radiants, Stones and Valves, are covered for a period of SIX MONTHS.
All Ceramic Baking Decks are covered for a period of THREE MONTHS. The installation of these replacement decks is the responsibility of the purchaser.
The extended Cyclone door warranty years 3 through 5 is a parts only warranty and does not include labor, travel, mileage or any other charges.
- EXCLUSIONS**
- ◆ Negligence or acts of God,
 - ◆ Thermostat calibrations after (30) days from equipment installation date,
 - ◆ Air and Gas adjustments,
 - ◆ Light bulbs,
 - ◆ Glass doors and door adjustments,
 - ◆ Fuses,
 - ◆ Char-broiler work decks and cutting boards,
 - ◆ Tightening of conveyor chains,
 - ◆ Adjustments to burner flames and cleaning of pilot burners,
 - ◆ Tightening of screws or fasteners,
 - ◆ Failures caused by erratic voltages or gas supplies,
 - ◆ Unauthorized repair by anyone other than a BAKERS PRIDE Factory Authorized Service Center,
 - ◆ Damage in shipment,
 - ◆ Alteration, misuse or improper installation,
 - ◆ Thermostats and safety valves with broken capillary tubes,
 - ◆ Accessories — spatulas, forks, steak turners, grate lifters, oven brushes, scrapers, peels, etc.,
 - ◆ Freight — other than normal UPS charges,
 - ◆ Ordinary wear and tear.
- INSTALLATION** Leveling and installation of decks, as well as proper installation and check out of all new equipment — per appropriate installation and use materials — is the responsibility of the dealer or installer, not the manufacturer.
- REPLACEMENT PARTS** BAKERS PRIDE genuine Factory OEM parts receive a (90) day materials warranty effective from the date of installation by a BAKERS PRIDE Factory Authorized Service Center.

This Warranty is in lieu of all other warranties, expressed or implied, and all other obligations or liabilities on the manufacturer's part. BAKERS PRIDE shall in no event be liable for any special, indirect or consequential damages, or in any event for damages in excess of the purchase price of the unit. The repair or replacement of proven defective parts shall constitute a fulfillment of all obligations under the terms of this warranty.

Form #U4177A 3/04