

USERGUIDE

# S900-II Configuration

## Version 2.1



### **WARNING - Reliance on this Manual Could Result in Severe Bodily Injury or Death!**

This manual is out-of-date and is provided only for its technical information, data and capacities. Portions of this manual detailing procedures or precautions in the operation, inspection, maintenance and repair of the product forming the subject matter of this manual may be inadequate, inaccurate, and/or incomplete and cannot be used, followed, or relied upon. Contact Conair at [info@conairgroup.com](mailto:info@conairgroup.com) or 1-800-654-6661 for more current information, warnings, and materials about more recent product manuals containing warnings, information, precautions, and procedures that may be more adequate than those contained in this out-of-date manual.

Logo definitions :



Warning, risks



Sepro robotique inventions



What to do ?



Document evolutions



Handy hints



Example



Innovation or information  
concerning a particular  
software version

## – CONTENTS –

<b>I – PARAMETER DEFINITION</b> .....	<b>2</b>
I – 1. Robot’s parameters .....	2
I – 1. 1. Accessing the parameters .....	2
I – 1. 2. Changing a parameter .....	4
I – 1. 3. Function of the parameters .....	4
I – 2. Axes’ parameters .....	55
I – 3. Saving and recovering the parameters .....	56
<b>II – PROCESSING THE MATERIAL SAFETY DEVICES</b> .....	<b>57</b>
<b>III – HARDWARE ARCHITECTURE</b> .....	<b>60</b>
III – 1. S900–II general block digram (for a brushless axis) .....	60
III – 2. The S900–II numeric control system .....	61
III – 3. The control cabinet boards .....	62
<b>IV – FAULT LIST</b> .....	<b>63</b>

**S900–II Configuration**  
**Version 2.1**

Characterizes the ....	Parameters	Page	Characterizes the ....	Parameters	Page
<u>ROBOT PARAMETERS</u>			Program number encoding inputs	540 → 547	50
Robot operation	1 → 17 29, 38 & 435	5 16 / 19	Safety outputs	550 → 554	51
Password	20 → 28	15	Outputs showing robot's status	560 → 568	52
Definition of the second arm	30 → 37	17	Interface outputs for IMM 1	570 → 578	53
Series communication	18 → 19 39 → 44	14 20	Interface outputs for IMM 2	579 → 587	54
CAN bus	45 → 125	22	Pneumatic high speed outputs	590 → 592	54
Floppy disk drive operation	126 → 131	22	<u>AXES' PARAMETERS</u>		
Screen colours definition	134 → 152	23	X axis adjustment	600 → 659	55
Reserved	153 → 165	–	PFC for X axis	662 → 740	
Type of IMM integrated commands	166 → 169	25	Y axis adjustment	746 → 795	
Type of operation with IMM 1	170 → 179	26	PFC for Y axis	798 → 876	55
Type of interface IMM 2	181	30	Z axis adjustment	882 → 931	
Reserved	182 → 189	–	PFC for Z axis	934 → 1012	
Pendant	190 → 197	31	B axis adjustment	1018 → 1067	
Definition of the customized keys	200 → 358	33	PFC for B axis	1070 → 1148	
Reserved	360 → 366	–	C axis adjustment	1154 → 1203	
Predefined actions	370 → 433	36	PFC for C axis	1206 → 1284	
Safety inputs	440 → 484	40	Numeric measured axis N1	1290 → 1300	
Interface inputs for IMM 1	490 → 499	45	Numeric measured axis N2	1304 → 1314	
Interface inputs for IMM 2	500 → 503	46	Analogue measured axis A1	1319 → 1326	
Reserved	504 → 509	–	Analogue measured axis A2	1331 → 1338	
External control inputs	510 → 539 548	46 48	Euromap 17 data	1340 → 1374	

The grey tinted areas represent the pre-calculated parameters, whose modifications are only taken into account after the robot's control cabinet has been powered up.

# I – PARAMETER DEFINITION

The parameters are the variables of the S900–II numeric control unit. They are used to characterize the robot, its environment as well as its means of communication with the environment.

## I – 1. Robot’s parameters

### I – 1. 1. Accessing the parameters

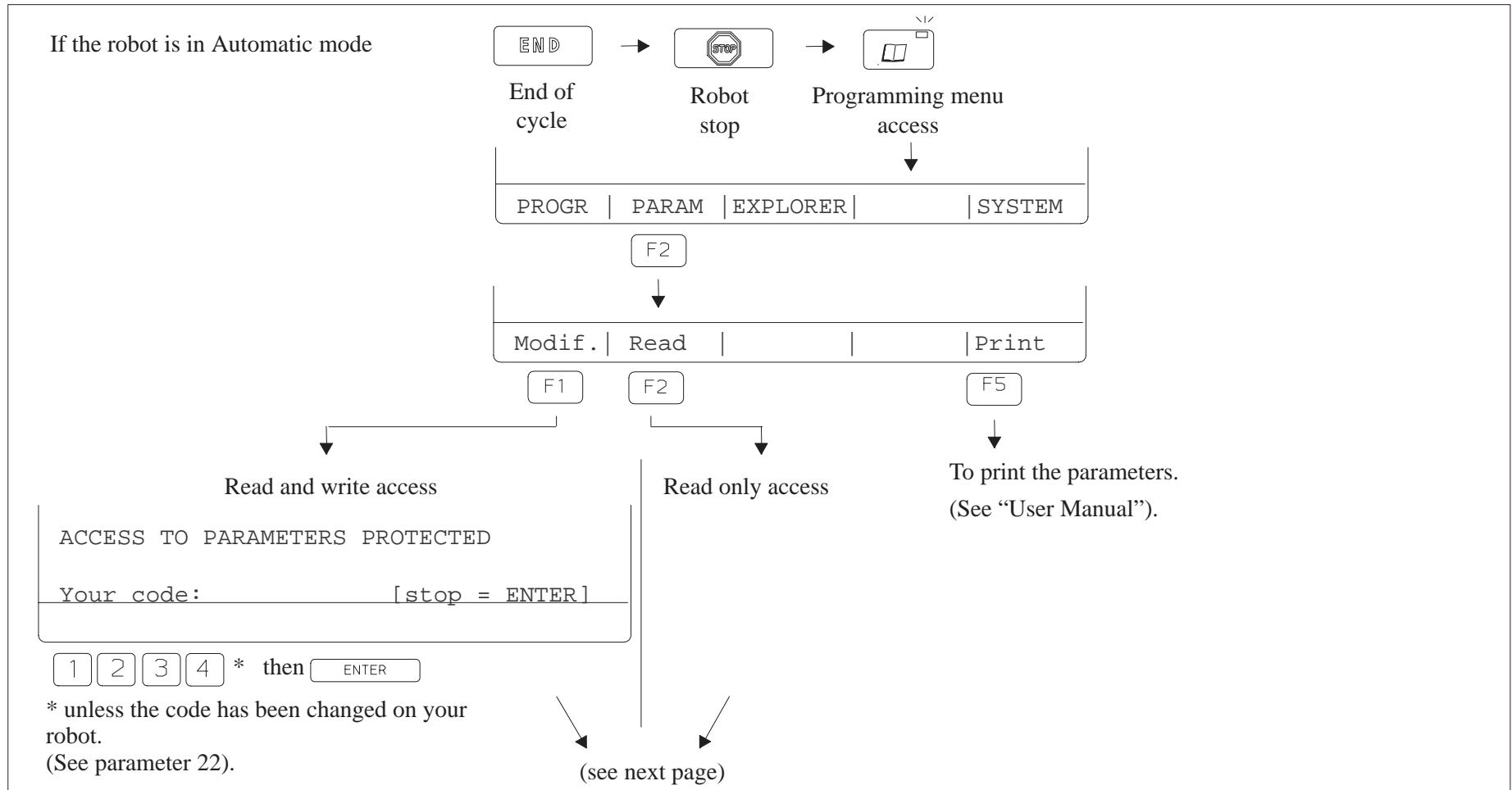

PARAMETERS		LIMITS		
P_0001 = 000000		0000 < 00000002		
CMD_OPER				
PC/E17	IMM	Keys	Actions	I/O
F1	F2	F3	F4	F5

F1 Direct access to the PC and Euromap 17 parameters (*Parameter 40*)

F2 Direct access to the IMM interface parameters (*Parameter 170*)

F3 Direct access to the key parameters (*Parameter 200*)

F4 Direct access to the action parameters (*Parameter 370*)

F5 Direct access to the inputs or outputs (*Parameter 440 and parameter 550*)

Other means of direct access exist :

Keys on keyboard	Direct access to parameters for :
	<i>1st pulse</i> : the X axis (Parameter 610) <i>2nd pulse</i> : the N1 axis (Parameter 1290)
	<i>1st pulse</i> : the Y axis (Parameter 746) <i>2nd pulse</i> : the N2 axis (Parameter 1304)
	<i>1st pulse</i> : the Z axis (Parameter 882) <i>2nd pulse</i> : the A1 axis (Parameter 1319)
	<i>1st pulse</i> : the B axis (Parameter 1018) <i>2nd pulse</i> : the A2 axis (Parameter 1331)
	<i>1st pulse</i> : the C axis (Parameter 1154) <i>2nd pulse</i> : rate of axis board 1 (Parameter 600)

Moving about in the parameters' list :

: To move back 10 parameters.



: To move forward 10 parameters.



: To move back one parameter (previous parameter).

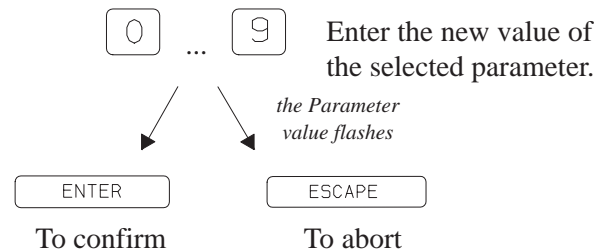

: To move forward one parameter (following parameter).

**I – 1. 2. Changing a parameter**

If the value entered on the keyboard is between the min and max limits, the value is saved. Otherwise, the value is not validated and the “The value is out of range” message appears on the screen.

Exit the parameter mode by pressing ESCAPE. If the parameters have been changed, the system displays : “Copying data to FLASHROM” for about 8 seconds.







Certain parameters (see list on page 1) are only taken into account after the robot’s control cabinet has been powered up. Consequently, you are strongly advised to power the robot’s cabinet down and then up again.

**I – 1. 3. Function of the parameters**

The function of each parameter is described in the following pages.

The default value is only indicative and corresponds to the values automatically downloaded after a general reset. In this case, start again with the parameter file corresponding to your robot (see File S of the robot file or download the “PARAM” file of diskette 1 of set 1, from a compatible PC). See chapter I – 3. page 56.

ROBOT OPERATION

PARAMETER	Abbreviation	Description	Parameter value	Corresponding function
<b>0001</b>	CMD_OPER	Type of operator commands	0	The commands are only activated from the Sepro pendant.
			1	Depending on the status of the input whose number is marked in parameter 510, the commands are either activated from the Sepro pendant or from the external inputs reserved for the commands (Parameters 511 to 539)  <u>Note</u> : In the "Commands from external inputs" mode, the pendant keys     can be used
			2	The commands are activated by the pendant and/or the IMM restart box (BRP).
			3	Depending on the status of the input whose number is marked in parameter 510, the commands are activated either from the Sepro pendant or from the IMM integrated commands (parameters 514, 515, 521, 526, 527 and 548).
<p>The commands concerned are :</p> <ul style="list-style-type: none"> <li>▶ the axes' movements in adjust mode (X+, X-, ...),</li> <li>▶ requests for cycle start, operation without the robot, stop at end of cycle, home return and tool change position (PCO).</li> </ul> <p>Using the values 1, 2 and 3 you can disconnect the pendant if the input defined in parameter 510 is at 1.</p>				
Default value : 0		Possible value : 0 -> 3	Interaction with other parameters : 173, 510 -> 539, 548.	

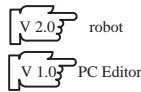



PARAMETER	Abbreviation	Description	Parameter value	Corresponding function
<b>0002</b>	CTRL_PRISE	Type of part grip controls	0	Standard control PP1 to PP8.
			1	Control by bit 32.
	The part presence can be controlled by detection (vacuum switch, end of course, proximity sensor, ...) or can be associated with the status of a bit, (bit 32) the result of a more complex equation (multiple part grips) carried out by the PLC. Checking by bit 32 is only valid with the PIP interface (parameter 171 = 1 or 2) and only for part grip in the IMM.			
	Default value : 0	Possible value : 0 → 1	Interaction with other parameters : 171	
<b>0003</b>	COD_NUM_PP	Type of program number encoding	0	None.
			1	Encoding limited to number on 4 inputs + parity input. Max : 16 programs (N° 0 to 15).
			2	Encoding extended to number on 7 inputs + parity input. Max : 100 programs (N° 0 to 99).
			3	Number encoded by the IMM with Euromap 17 (WWORD 102).
			4	Number encoded by supervisor word with JBUS option (MotCod 1, Word 58).
	The table on the following page shows the encoding for the 100 programs in pure binary. 1 represents the bit weighted 1 (parameter 540), 2 represents the bit weighted 2 (parameter 541), 4 represents the bit weighted 4 (parameter 542), ...8 → 543, 16 → 544, 32 → 545, 64 → 546 and p represents the parity bit (parameter 547)*.			
Default value : 0	Possible value : 0 → 4	Interaction with other parameters : 4, 540 → 547		

\* The binary code must contain an even number of inputs at 1 to be valid. Therefore, set the parity bit to 1 or 0.

Note : You are strongly advised not to use program number 0 as, if there is no encoding, this program is selected.

n°	p	64	32	16	8	4	2	1	n°	p	64	32	16	8	4	2	1	n°	p	64	32	16	8	4	2	1	n°	p	64	32	16	8	4	2	1
0	0	0	0	0	0	0	0	0	25	1	0	0	1	1	0	0	1	50	1	0	1	1	0	0	1	0	75	0	1	0	0	1	0	1	1
1	1	0	0	0	0	0	0	1	26	1	0	0	1	1	0	1	0	51	0	0	1	1	0	0	1	1	76	1	1	0	0	1	1	0	0
2	1	0	0	0	0	0	1	0	27	0	0	0	1	1	0	1	1	52	1	0	1	1	0	1	0	0	77	0	1	0	0	1	1	0	1
3	0	0	0	0	0	0	1	1	28	1	0	0	1	1	1	0	0	53	0	0	1	1	0	1	0	1	78	0	1	0	0	1	1	1	0
4	1	0	0	0	0	1	0	0	29	0	0	0	1	1	1	0	1	54	0	0	1	1	0	1	1	0	79	1	1	0	0	1	1	1	1
5	0	0	0	0	0	1	0	1	30	0	0	0	1	1	1	1	0	55	1	0	1	1	0	1	1	1	80	0	1	0	1	0	0	0	0
6	0	0	0	0	0	1	1	0	31	1	0	0	1	1	1	1	1	56	1	0	1	1	1	0	0	0	81	1	1	0	1	0	0	0	1
7	1	0	0	0	0	1	1	1	32	1	0	1	0	0	0	0	0	57	0	0	1	1	1	0	0	1	82	1	1	0	1	0	0	1	0
8	1	0	0	0	1	0	0	0	33	0	0	1	0	0	0	0	1	58	0	0	1	1	1	0	1	0	83	0	1	0	1	0	0	1	1
9	0	0	0	0	1	0	0	1	34	0	0	1	0	0	0	1	0	59	1	0	1	1	1	0	1	1	84	1	1	0	1	0	1	0	0
10	0	0	0	0	1	0	1	0	35	1	0	1	0	0	0	1	1	60	0	0	1	1	1	1	0	0	85	0	1	0	1	0	1	0	1
11	1	0	0	0	1	0	1	1	36	0	0	1	0	0	1	0	0	61	1	0	1	1	1	1	0	1	86	0	1	0	1	0	1	1	0
12	0	0	0	0	1	1	0	0	37	1	0	1	0	0	1	0	1	62	1	0	1	1	1	1	1	0	87	1	1	0	1	0	1	1	1
13	1	0	0	0	1	1	0	1	38	1	0	1	0	0	1	1	0	63	0	0	1	1	1	1	1	1	88	1	1	0	1	1	0	0	0
14	1	0	0	0	1	1	1	0	39	0	0	1	0	0	1	1	1	64	1	1	0	0	0	0	0	0	89	0	1	0	1	1	0	0	1
15	0	0	0	0	1	1	1	1	40	0	0	1	0	1	0	0	0	65	0	1	0	0	0	0	0	1	90	0	1	0	1	1	0	1	0
16	1	0	0	1	0	0	0	0	41	1	0	1	0	1	0	0	1	66	0	1	0	0	0	0	1	0	91	1	1	0	1	1	0	1	1
17	0	0	0	1	0	0	0	1	42	1	0	1	0	1	0	1	0	67	1	1	0	0	0	0	1	1	92	0	1	0	1	1	1	0	0
18	0	0	0	1	0	0	1	0	43	0	0	1	0	1	0	1	1	68	0	1	0	0	0	1	0	0	93	1	1	0	1	1	1	0	1
19	1	0	0	1	0	0	1	1	44	1	0	1	0	1	1	0	0	69	1	1	0	0	0	1	0	1	94	1	1	0	1	1	1	1	0
20	0	0	0	1	0	1	0	0	45	0	0	1	0	1	1	0	1	70	1	1	0	0	0	1	1	0	95	0	1	0	1	1	1	1	1
21	1	0	0	1	0	1	0	1	46	0	0	1	0	1	1	1	0	71	0	1	0	0	0	1	1	1	96	0	1	1	0	0	0	0	0
22	1	0	0	1	0	1	1	0	47	1	0	1	0	1	1	1	1	72	0	1	0	0	1	0	0	0	97	1	1	1	0	0	0	0	1
23	0	0	0	1	0	1	1	1	48	0	0	1	1	0	0	0	0	73	1	1	0	0	1	0	0	1	98	1	1	1	0	0	0	1	0
24	0	0	0	1	1	0	0	0	49	1	0	1	1	0	0	0	1	74	1	1	0	0	1	0	1	0	99	0	1	1	0	0	0	1	1



PARAMETER	Abbreviation	Description	Parameter value	Corresponding function
<b>0004</b>	CHG_PP_AUTO	Automatic program change	0	No automatic program change.
			1	Automatic program change. The code is positioned differently, depending on the status of parameter 3 : -> parameter 3 at 0, 1 or 2, the code number is given by the external inputs (parameters 540 to 547) and the code validation by the input whose number is given in parameter 511. -> parameter 3 at 3 or 4, the code number is given by the supervisor system (MotCod1, WORD 58) or WWORD 102 with Euomap 17.
	The automatic program change is validated either : <ul style="list-style-type: none"> <li>▶ by the 128 weighted bit of Mot Dial (WORD 43),</li> <li>▶ or by bit 33 (JBus and Euomap 17).</li> </ul>			
Default value :	Possible value :	Interaction with other parameters : 3, 511, 540 -> 547		
0	0 -> 1			

See the example of automatic program change in the S900–II Programming Manual Level 1.

PARAMETER	Abbreviation	Description	Parameter value	Corresponding function
<b>0005</b>	ROT_RGT_GEN	Type of general stacking rotations	0	<p>The rotation word (RotWrd) contains the “rotation” bits used in the main program to control the non–standard movements (Bits 16 to 20).</p> <p>E.g. : IF BIT.016 OUT 025</p> <p>It is not possible to set this parameter in teach mode ; the “RotWrd” must be entered directly.</p>
			1	<p>The rotation word (RotWrd) is the image of the standard mechanical rotations during the teaching :</p> <ul style="list-style-type: none"> <li>▶ ACT09 : “Gripper horizontal”,</li> <li>▶ ACT10 : “Gripper vertical ”,</li> <li>▶ ACT13 : “Rotation 2 + direction”,</li> <li>▶ ACT14 : “Rotation 2 - direction”,</li> <li>▶ ACT16 : “Rotation 2 intermed. position”.</li> </ul>
	<p>In the general stacking subroutines, a rotation word can be associated with each part to define its position before being released, during the teaching process.</p>			
	Default value :	Possible value :	Interaction with other parameters :	
	0	0 -> 1		

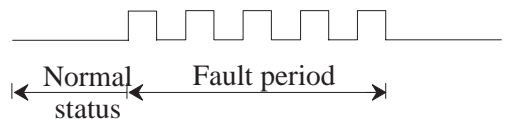
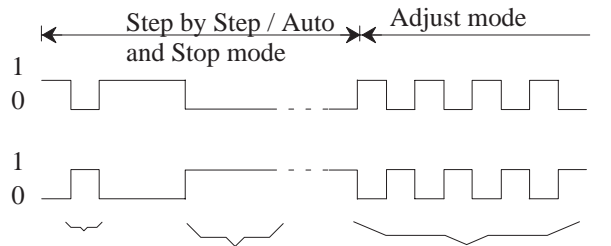

PARAMETER	Abbreviation	Description	Parameter value	Corresponding function
<b>0006</b>	TIMOUT_ST	Time–Out value between steps in 1/10 seconds	0000 -> 9999	Indicates the authorised waiting time for a control (input or bit) in a step before the fault D_10 appears.  Its validity is conditioned by parameter No. 7.
	Default value : 50	Possible value : 0 -> 9999	Interaction with other parameters : 7	
<b>0007</b>	DEF_TIMOUT	Type of Time–Out between steps	0	Fault for the main program (PRG) and the parallel subroutine (SPP).
			1	Fault for the parallel subroutine (SPP), just signalled for the main program (PRG).
			2	Fault for the main program (PRG), just signalled for the parallel subroutine (SPP).
			3	No fault, just signalled for the main program (PRG) and the parallel subroutine (SPP).
	<p>A software “watchdog” whose length is set by parameters (No 6 and 8) constantly overlooks the sequential running of the program. If there is a delay between 2 steps greater than that of the “watchdog” (input or bit absent), the robot goes into fault D_10 . However, there are cases when you do not want to be in fault mode. It is therefore possible to set the fault mode or signalling parameters globally : in a main program (PRG) and/or in a parallel subroutine (SPP)</p>			
Default value : 0	Possible value : 0 -> 3	Interaction with other parameters : 6, 8		

PARAMETER	Abbreviation	Description	Parameter value	Corresponding function
<b>0008</b>	TIMOUT_PP	Value of part grip Time-Out in 1/10 seconds	0 → 999	<p>If the robot parameters are set with the IMM interface (parameter No. 171 = 1 or 2), a special delay is applied to the part grip in the IMM. (So that the IMM is not open for too long).</p> <p>After this delay, the robot executes an automatic home return if the part presence control is not activated.</p>
	If the value P8 > P6 then P6 has priority			
	Default value : 30	Possible value : 0 → 999	Interaction with other parameters : 6, 171	
<b>0009</b>	TYP_ALARM	Type of alarm signal	0	<p>The alarm output (parameter 553) flashes.</p> <p>Alarm OUT 000 </p>
			1	<p>The alarm output (parameter 553) is the complement of the fault output (parameter 552).</p> <p>Fault OUT 001 </p> <p>Alarm OUT 000</p> <p>Period when the robot is in fault mode = Alarm</p>
	Default value : 0	Possible value : 0 → 1	Interaction with other parameters : 552, 553	

PARAMETER	Abbreviation	Description	Parameter value	Corresponding function
<b>0010</b>	DUR_ALARM	Length of operator alarm in 1/10 seconds	20 → 300	Length of operator alarm (output of parameter 554). Delayed start-up = parameter 10 + parameter 11 only if parameter 554 ≠ 128, otherwise there is no delayed start-up.
	The start-up is only delayed if  has been pushed more than 20 seconds ago.			
	Default value : 20	Possible value : 20 → 300	Interaction with other parameters : 11, 554	
<b>0011</b>	DELAI_START	Delay before robot cycle starts in 1/10 seconds	0 → 300	Length of delay before robot cycle starts. Delayed start-up = parameter 10 + parameter 11 only if parameter 554 ≠ 128, otherwise there is no delayed start-up.
	The start-up is only delayed if  has been pushed more than 20 seconds ago.			
	Default value : 0	Possible value : 0 → 300	Interaction with other parameters : 10, 554	
<b>0012</b>	CP_STAT_ROB	Robot's status copied onto the outputs	0	No copy
			1	Status copied.
	<p>For some applications, a link is necessary between the robot and an external automatic device. The basic “dialogue” is possible with the inputs/outputs of each system. For this, the robot status is copied onto the outputs, whose numbers are given in parameters 560 to 568 :</p> <p style="padding-left: 40px;">▶ robot in stop, auto, step by step, or adjust mode ; robot in HR, PCO, in cycle or in fault...etc...</p> <p>The “fault” (parameter 552) and “alarm” (parameter 553) status are not conditioned by this parameter.</p>			
Default value : 0	Possible value : 0 → 1	Interaction with other parameters : 560 → 568		

PARAMETER	Abbreviation	Description	Parameter value	Corresponding function
<b>0013</b>	PLC_ALL_MOD	<b>RESERVED</b>		
	Default value : 0	Possible value :	Interaction with other parameters :	
<b>0014</b>	OUT_IN_STOP	Output status maintained when robot is stopped and during mode changes.	0	Standard function ; the outputs go to 0 when you quit automatic or step by step modes.
			1	All the outputs keep their status whatever the operating mode. They only go to 0 if there is a fault.
	This function does not concern : – the outputs reflecting the robot status, – the outputs attributed to the ejector and core puller commands.			
	Default value : 0	Possible value : 0 -> 1	Interaction with other parameters : 171 560 -> 568, 574 -> 578	
<b>0015</b>	RO_REGL	Home return forced each time you move into adjust mode 	0	<u>Without</u> : no procedure is requested when you move into adjust mode. This means much more flexibility when fine tuning.
			1	<u>With</u> : Each time you move into adjust mode (except when teaching positions), a home return is requested (simple or total).
	It is possible to force the operator to carry out a home return before starting the cycle. A disengaging sequence is executed after movements in adjust mode, such as the arm descent.			
	Default value : 1	Possible value : 0 -> 1	Interaction with other parameters :	

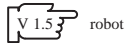

PARAMETER	Abbreviation	Description	Parameter value	Corresponding function
<b>0016</b>	BACKUP_MEM	Type of backup memory	0	Internal memory. Size depends on option (32 or 128 Kbytes). See User Manual, “Robot configuration” paragraph.
			1	RESERVED
	Default value : 0	Possible value : 0 -> 1	Interaction with other parameters :	
<b>0017</b>	BACKUP_UNIT	<b>RESERVED</b>		
	Default value : 0	Possible value :	Interaction with other parameters :	
 <b>0018</b>	RESERVED	JBUS reply time in ms		RESERVED
	Default value : 0	Possible value : 0 -> 999	Interaction with other parameters :	
 <b>0019</b>	RESERVED	JBUS time-out in ms		RESERVED
	Default value : 400	Possible value : 40 -> 400	Interaction with other parameters :	

PASSWORDS				
PARAMETER	Abbreviation	Description	Parameter value	Corresponding function
<b>0020</b>	PWD_EDIT	Password for program edition	0	No password
			1 -> 9999	Password value
	Default value : 0	Possible value : 0 -> 9999	Interaction with other parameters : 28	
<b>0022</b>	PWD_PARAM	Password for setting parameters or calibration	0	No password
			1 -> 9999	Password value
	Default value : 1234	Possible value : 0 -> 9999	Interaction with other parameters : 28	
<b>0024</b>	PWD_MAINT	Password for saving the maintenance	0	No password
			1 -> 9999	Password value
	Default value : 0	Possible value : 0 -> 9999	Interaction with other parameters : 28	
<b>0026</b>	PWD_CHMOD	Password for mode change	0	No password
			1 -> 9999	Password value
	Can also be used to change the program number.			
	Default value : 0	Possible value : 0 -> 9999	Interaction with other parameters : 28	

PARAMETER	Abbreviation	Description	Parameter value	Corresponding function
<b>0027</b>	PWD_NUM_PP	Password for selecting program number	0	No password
			1 -> 9999	Password value
	Default value : 0	Possible value : 0 -> 9999	Interaction with other parameters : 28	
<b>0028</b>	DUR_PWD	Time passwords are maintained in seconds	0 -> 120	Length during which, once the password has been entered, it is no longer necessary to enter it again to access the same mode.
	Default value : 120	Possible value : 0 -> 120	Interaction with other parameters : 20, 22, 24, 26, 27	

**ROBOT OPERATION**

PARAMETER	Abbreviation	Description	Parameter value	Corresponding function
<b>0029</b>	OUT_REGL	Locks the pneumatic movements associated with the predefined actions .	0	The movement is activated as soon as the corresponding key is pressed.
			1	Once the action key has been pressed, you must press <input type="button" value="ENTER"/> or <input type="button" value="START"/> within 5 seconds to enable the movement. The part grips and releases do not have to be validated in this way.
	Default value : 0	Possible value : 0 -> 1	Interaction with other parameters :	

 v 1.2.3 robot

 v 0.4.3 PC Editor





**DEFINITION OF THE SECOND ARM**

PARAMETER	Abbreviation	Description	Parameter value	Corresponding function
<b>0030</b>	FAST_UP_1	Fast ascent 1 in ms	0 → 999	High speed output pulse length for fast pneumatic ascent 1 (parameter 590).
	Valeur par Default value : 50	Possible value : 0 → 999	Interaction with other parameters : 36, 37, 590	
<b>0031</b>	FAST_UP_2	Fast ascent 2 in ms	0 → 999	High speed output pulse length for fast pneumatic ascent 2 (parameter 591).
	Default value : 50	Possible value : 0 → 999	Interaction with other parameters : 36, 37, 591	
<b>0032</b>	FAST_DOWN_1	Fast descent 1 in ms	0 → 999	High speed output pulse length for fast pneumatic descent 1 (parameter 590).
	Default value : 50	Possible value : 0 → 999	Interaction with other parameters : 36, 37, 590	
<b>0033</b>	FAST_DOWN_2	Fast descent 2 in ms	0 → 999	High speed output pulse length for fast pneumatic descent 2 (parameter 591).
	Default value : 50	Possible value : 0 → 999	Interaction with other parameters : 36, 37, 591	
<b>0034</b>	AV_Y	Fast Y advance in ms	0 → 999	High speed output pulse length for fast Y pneumatic advance (parameter 592).
	Default value : 50	Possible value : 0 → 999	Interaction with other parameters : 36, 37, 592	

PARAMETER	Abbreviation	Description	Parameter value	Corresponding function
<b>0035</b>	REC_Y	Fast Y retreat in ms	0 → 999	High speed output pulse length for fast pneumatic Y retreat (parameter 592).
	Default value : 50	Possible value : 0 → 999	Interaction with other parameters : 36, 37, 592	
<b>0036</b>	VALID_AM	Validation of high speeds only in the machine axis	0	The high speed pulses for the pneumatic axes are valid whatever the robot position.
			1	The high speed pulses for the pneumatic axes are only valid if the robot is in the machine axis.
	Default value : 0	Possible value : 0 → 1	Interaction with other parameters : 30 → 35, 37	
<b>0037</b>	TYP_BRAS_2	Type of arm 2	0	None.
			1	Electric.
			2	Pneumatic with mechanical stops.
			3	Tandem pneumatic.
	Default value : 0	Possible value : 0 → 3	Interaction with other parameters : 370 → 377, 396, 397	

ROBOT OPERATION

PARAMETER	Abbreviation	Description	Parameter value	Corresponding function
<b>0038</b>	DESC_REGL	Locks movements outside the Arm Free Safety area (SBD) in adjust mode (see page 58).	0	Movements not locked.
			1	The robot movements in adjust mode are prohibited when the robot is outside of the SBD area. In this case, the movements are blocked and the message Impossible to descend in this area appears.  The pneumatic movements of the second arm are also blocked.  The ascent of the vertical axes is always possible.  All movements are possible if you keep the  key pressed down.
	Default value : 0	Possible value : 0 -> 1		

 V 1.2 robot

 V 0.4 PC Editor

<b>0435</b>	VEL_ACC	Association of the VEL and ACC instructions for SAP	0	VEL and ACC are not associated (the commands are independent).
			1	The VEL instruction in an SAP program has an effect on both the speed and the acceleration of the axis.
	Default value : 0	Possible value : 0 -> 1	Interaction with other parameters :	

 V 2.0 robot

 V 1.0 PC Editor

SERIES COMMUNICATION				
PARAMETER	Abbreviation	Description	Parameter value	Corresponding function
<b>0039</b>	TYP_E17	Euomap 17 version	0	Version 1.0 (old machines)
			1	Version 1.1.
	Default value : 1	Possible value : 0 -> 1	Interaction with other parameters :	
<b>0040</b>	NUM_SLAV_PC	PC slave number	0 -> 99	Number given to the robot in dialogue with the PC or the Host.
	This parameter is used by the JBUS protocol in communication with the Host.			
	Default value : 1	Possible value : 0 -> 99	Interaction with other parameters :	
<b>0041</b>	BDRATE_PC	PC / JBUS transmission speed	0	2400 Bauds.
			1	9600 Bauds.
	Default value : 1	Possible value : 0 -> 1	Interaction with other parameters :	
<b>0042</b>	NUM_SLAV_E17	Euomap 17 slave number	0 -> 99	Number given to the robot in dialogue with the IMM via Euomap 17.
	Default value : 0	Possible value : 0 -> 99	Interaction with other parameters :	

PARAMETER	Abbreviation	Description	Parameter value	Corresponding function
<b>0043</b>	BDRATE_E17	Euromap 17 transmission speed	0	2400 Bauds.
			1	9600 Bauds.
	Default value : 1	Possible value : 0 -> 1	Interaction with other parameters :	
<b>0044</b>	TRANS_PP	Systematic program transfer	0	No : program is not transferred if it already exists in the robot's memory.
			1	Yes : if you want the program to be sent, even if it already exists in the robot's memory, the parameter must be set to 1.
	The procedure for downloading a program from the IMM anticipates that the latter asks the robot whether the program to be sent already exists in the robot's memory. If the robot replies Yes, there is no transfer and the program already in the robot will be executed.			
	Default value : 0	Possible value : 0 -> 1	Interaction with other parameters :	



---

CAN BUS

---

**Note :** Parameters 45 to 125 characterize the CAN network. They are described on the “CAN and axes configuration” Manual. These parameters can only be changed by people who have followed a Sepro robotique specific training course. Consult our After Sales Service for any changes.

---

V 2.0 robot  
V 1.0 PC Editor

FLOPPY DISK DRIVE OPERATION

Parameters 126 to 131 are used to define the operation of the floppy disk drive. They are described in the “CAN and axes Configuration” Manual. Modifying one of these parameters without having first consulted our After Sales Service may lead to the malfunctioning of the floppy disk drive.

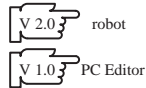

**DEFINITION OF THE SCREEN COLOURS (IF COLOUR PENDANT OPTION)**

Parameters 134 to 150 are used to define the screen display colours. The screen is divided into 5 windows, numbered 1 to 5. Each window is defined by a parameter in which 4 colours are coded :

- the background colour of the active window
- the text colour of the active window
- the background colour of the inactive window
- the text colour of the inactive window

Background colour of window 3

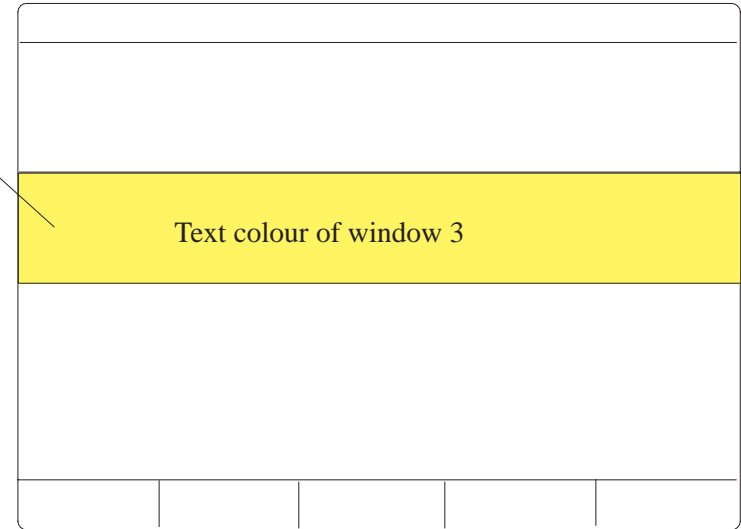

The colours are coded in hexadecimal. The following table indicates the colour coding as well as the colour obtained with a monochrome display (colour marked in brackets).

code	corresponding colour	code	corresponding colour	code	corresponding colour	code	corresponding colour
0	black (black)	4	dark red (grey5)	8	black (grey3)	C	bright red (grey1)
1	dark blue (black)	5	dark purple (grey5)	9	bright blue (grey3)	D	bright purple (grey1)
2	dark green (grey6)	6	dark yellow (grey4)	A	bright green (grey2)	E	bright yellow (white)
3	blue (grey6)	7	grey (grey4)	B	bright light blue (grey2)	F	white (white)

The value of the parameter is as follows :



bright purple  
D

dark yellow  
6

dark red  
4

bright light blue  
B

—> Value of corresponding parameter : D64B

<b>PARA-METER</b>	<b>Abbreviation</b>	<b>Description</b>	<b>Default value and corresponding colour in the active window / inactive window</b>		<b>Colour suggestion</b>
<b>134</b>	DEFT_FEN	Default window	0C0C	Black text – red background / red background – black text	0C0C
<b>135</b>	MONI_FEN_4	Monitor window 4	0F07	Black text – white background / black text – grey background	0B03
<b>136</b>	UTIL_FEN_4	User window 4	0F07	Black text – white background / black text – grey background	0B03
<b>137</b>	EXEC_FEN_1	Execution window 1	0F07	Black text – white background / black text – grey background	0E0E
<b>138</b>	EXEC_FEN_2	Execution window 2	0F07	Black text – white background / black text – grey background	0B03
<b>139</b>	EXEC_FEN_3	Execution window 3	0F07	Black text – white background / black text – grey background	0B03
<b>140</b>	EXEC_FEN_4	Execution window 4	0F07	Black text – white background / black text – grey background	0B03
<b>141</b>	EXEC_FEN_5	Execution window 5	0F07	Black text – white background / black text – grey background	0E0E
<b>142</b>	REGL_FEN_1	Adjust window 1	0F07	Black text – white background / black text – grey background	0E0E
<b>143</b>	REGL_FEN_2	Adjust window 2	0F07	Black text – white background / black text – grey background	0A02
<b>144</b>	REGL_FEN_3	Adjust window 3	0F07	Black text – white background / black text – grey background	0A02
<b>145</b>	REGL_FEN_4	Adjust window 4	0F07	Black text – white background / black text – grey background	0A02
<b>146</b>	REGL_FEN_5	Adjust window 5	0F07	Black text – white background / black text – grey background	0E0E
<b>147</b>	PROG_FEN_1	Programming window 1	0F07	Black text – white background / black text – grey background	0E0E
<b>148</b>	PROG_FEN_2	Programming window 2	0F07	Black text – white background / black text – grey background	0B03
<b>149</b>	PROG_FEN_4	Programming window 4	0F07	Black text – white background / black text – grey background	0B03
<b>150</b>	PROG_FEN_5	Programming window 5	0F07	Black text – white background / black text – grey background	0E0E
<b>151</b>	APPR_EXEC	Teaching in execution window	0F07	Black text – white background / black text – grey background	0A02
<b>152</b>	APPR_REG	Teaching in adjust window	0F07	Black text – white background / black text – grey background	0A02

V 2.0.3 robot

V 1.0.3 PC Editor

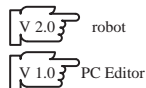



**TYPE OF IMM INTEGRATED COMMANDS**



PARAMETER	Abbreviation	Description	Parameter value	Corresponding function
<b>0166</b>	TYP_PRESSE_1	Type of IMM associated with the robot	0 → 999	This <b>Reserved</b> parameter is used to code the type of IMM associated with the robot. The type and generation of the IMM command are marked amongst other things.
	Default value : 0	Possible value : 0 → 999	Interaction with other parameters :	
<b>0167</b>	BLOC_CDE_PRESSE_1	Blocking the IMM integrated commands	0	The IMM integrated commands are always effective.
			1	The Reset, Home Return and Without Robot commands integrated into the IMM do not work when the latter is in semi-automatic or automatic mode (input MASA = 1, IN_AUTO_MACH1 <sub>[498]</sub> ).
	Default value : 0	Possible value : 0 → 1	Interaction with other parameters : 1	
<b>0168</b>	TYP_PRESSE_2	<b>RESERVED</b>	0 → 999	
	Default value : 0	Possible value : 0 → 999	Interaction with other parameters :	
<b>0169</b>	BLOC_CDE_PRESSE_2	<b>RESERVED</b>		
	Default value : 0	Possible value : 0 → 1	Interaction with other parameters :	

## TYPE OF OPERATION WITH INJECTION MOULDING MACHINE (IMM) 1

PARAMETER	Abbreviation	Description	Parameter value	Corresponding function
<b>0170</b>	TYPE_ACCES_1	Type of access to IMM 1	0	Vertical access.
			1	Lateral access.
			2	Axial vertical access.
			3	Mixed access (vertical or lateral). The selection is made by the input of parameter 453.
	Default value : 0	Possible value : 0 → 3	Interaction with other parameters : 453	
<b>0171</b>	TYP_INTERFACE_1	Type of interface with IMM 1	0	No interface.
			1	For Injection Moulding Machine (IMM) with Euromap 12 as standard
			2	IMM cycle validation maintained, for Injection Moulding Machine (IMM) with SPI as standard.
			3	General handling.
	Default value : 1	Possible value : 0 → 3	Interaction with other parameters :	

PARAMETER	Abbreviation	Description	Parameter value	Corresponding function
<b>0172</b>	TAKE_PART_1	Type of reset of the part made memory   robot  PC Editor	0	Disappearance of the “IMM in automatic or semi–automatic” data item (parameter 498) or disappearance of the “gate closed” signal (parameter 496) or pressing the pendant RESET key resets the part made memory to zero.
			1	Disappearance of the “IMM in automatic or semi–automatic” data item (parameter 498) or disappearance of the “gate closed” signal (parameter 496) triggers a stop at the end of the cycle and the question “Part to be taken in the MOULD ?“ is asked.
			2	The part made memory is only reset to zero by an operator reset. See parameter 173.
	Default value : 0	Possible value : 0 → 2	Interaction with other parameters : 173, 496, 498	
<b>0173</b>	RESET_1	Part reset to restart the IMM	0	Using the RESET key of the pendant only.
			1	Using the RESET button of the IMM 1 restart box only (BRP1).
			2	Using the pendant RESET key or the RESET button of the IMM 1 restart box (BRP1).
			3	Part made memory is not reset.
	Default value : 0	Possible value : 0 → 3	Interaction with other parameters : 1, 172	

PARAMETER	Abbreviation	Description	Parameter value	Corresponding function
<b>0174</b>	RLCE_ATCP_1	Type of anticipated restart for IMM 1	0	No anticipated restart.
			1	“Auto–adaptative” anticipated restart.
			2	Anticipated restart with programmed time delay.
	See “Anticipated restart” chapter in the Programming Level 1 Manual.			
	Default value : 0	Possible value : 0 → 2	Interaction with other parameters : 175 – 176	
<b>0175</b>	DELAI_RLCE_1	Default length of the IMM 1 restart in ms	0 → 9999 P174 = 1	For the auto–adaptative anticipated restart, this length of time is used as the basis by which the system delays the machine cycle validation (VCM) for the first cycle (this basic value is used after each robot stop).
			0 → 9999 P174 =2	For the anticipated restart with programmed time delay, this time length is double the minimum accepted programmed time delay.
			Interaction with other parameters : 174	
		Default value : 5000	Possible value : 0 → 9999	
<b>0176</b>	SECU_RLCE_MIN_1	Minimum safety margin for IMM 1 restart in ms	0 → 9999	The system checks that the time lapse between the appearance of the “Arm outside Mould” information (BHM described in chapter II – page 57) and the loss of “Machine Open” (MO) is not less than this safety margin.
		Default value : 100	Possible value : 0 → 9999	Interaction with other parameters : 174

PARAMETER	Abbreviation	Description	Parameter value	Corresponding function
<b>0177</b>	PRESSE_START 1	Robot cycle start given by IMM 1	0	The cycle start, given by the IMM via the Euromap 17 word “Mode Word” (MW)(WWORD104), is not taken into account.
			1	The cycle start, given by the IMM via the Euromap 17 word “Mode Word” (MW), is taken into account.
	Default value : 0	Possible value : 0 -> 1	Interaction with other parameters :	
<b>0178</b>	POSE_INSERT_1	Access to the Await end of robot cycle command	0	The  key does not give access to the Await end of machine cycle \$ command.
			1	The  key gives access to the Await end of robot cycle and Await end of machine cycle \$ commands.
	An example of programming with insert placing is given in the Programming Level 1 Manual.			
	Default value : 0	Possible value : 0 -> 1	Interaction with other parameters :	
<b>0179</b>	DELTA_VCM_SBD_1	Time delay in ms applied to the Machine Cycle Validation (VCM) output when the Arm Free Safety (SBD) goes to 1.	0 -> 100	A cascade connection of several relays on the “Arm Free Safety” (SBD) signal delays this signal compared to the “Machine Cycle Validation” (VCM) one. This parameter is used to cancel this delay which puts some IMMs into fault.
				The system counts down in 10 ms.
	Default value : 0	Possible value : 0 -> 100	Interaction with other parameters :	

 V 1.3 robot

 V 0.5 PC Editor

 V 2.0 robot

 V 1.0 PC Editor











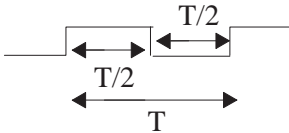



TYPE OF OPERATION WITH IMM 2

PARAMETER	Abbreviation	Description	Parameter value	Corresponding function
<b>0181</b>	TYP_INTERFACE_2	Type of interface with IMM 2	0	No interface.
			1	For Injection Moulding Machine (IMM) with Euromap 12 as standard.
			2	IMM cycle validation maintained (for Injection Moulding Machines (IMM) with SPI as standard).
			3	General handling.
	If this parameter is at 1 or 2, it is possible to access the core puller and ejector commands for IMM 2.			
Default value : 0	Possible value : 0 -> 3	Interaction with other parameters : 500 -> 503		

















 1.3 robot

 0.5 PC Editor

PENDANT				
PARAMETER	Abbreviation	Description	Parameter value	Corresponding function
<b>0190</b>	EXTINCTION	Time before screen goes into stand-by in minutes	0	The screen does not go into stand-by.
			1 -> 10	If you do not press a key during this time, the screen goes into stand-by.
	Default value : 3	Possible value : 0 -> 10	Interaction with other parameters :	
<b>0191</b>	TYP_BIP	Type of audible alarm	0	Intermittent.
			1	Continuous.
	Default value : 1	Possible value : 0 -> 1	Interaction with other parameters : 192, 193	
<b>0192</b>	PERIOD_BIP	Length of audible alarm in 1/10 seconds	100 -> 500	Length of beeps if there is an alarm.
	Default value : 100	Possible value : 100 -> 500	Interaction with other parameters : 191, 193	
<b>0193</b>	RATIO_BIP	Cyclic report of the audible alarm in percentage (%)	25 -> 75	Value of the cyclic report of the audible alarm. 
				Default value : 50

PARAMETER	Abbreviation	Description	Parameter value	Corresponding function
<b>0194</b>	BIP_CLAVIER	Length of beeps for the pendant keys in ms	0	No beeps.
			1 → 50	Length of beep each time a pendant key is pressed.
	Default value : 20	Possible value : 0 → 50	Interaction with other parameters :	
<b>0195</b>	ROT_ELEC_1	Electric Rotation 1	0	Rotation 1 is pneumatic, the  and  keys are used to activate ACTIONS 9 and 10.
			1	Rotation 1 is electric, the  and  keys are used to activate the B axis (4th electric axis)
	Default value : 0	Possible value : 0 → 1	Interaction with other parameters : 384 → 387	
<b>0196</b>	ROT_ELEC_2	Electric Rotation 2	0	Rotation 2 is pneumatic, the  and  keys are used to activate ACTIONS 13 and 14.
			1	Rotation 2 is electric, the  and  keys are used to activate the C axis (5th electric axis). In this case, the  key has no effect.
	Default value : 0	Possible value : 0 → 1	Interaction with other parameters : 392 → 395	
<b>0197</b>	BLOC_TORTUE	Tortoise blocked outside of adjust mode	0	The  key is effective in all modes.
			1	The  key is only effective in adjust mode 
	Default value : 0	Possible value : 0 → 1	Interaction with other parameters :	

**DEFINITION OF CUSTOMIZED KEYS**

The         keys  
as well as        

can be customized. The process for allocating an instruction is described in detail for the key G. The principle is the same for the other keys ; the table on page 35 gives the numbers of the corresponding parameters.

PARAMETER	Abbreviation	Description	Parameter value	Corresponding function
<b>0200</b>	NB_APPUL_G	Number of pulses on key G	0	Key not valid.
			1	Only the first pulse will be taken into account.
			2	The first 2 pulses will be taken into account.
			3	The first 3 pulses will be taken into account.
	4	The first 4 pulses will be taken into account.		
	Default value : 0	Possible value : 0 → 4	Interaction with other parameters : 202, 204, 206, 208	

Note : In adjust mode, only the first pulse is managed.

PARAMETER	Abbreviation	Description	Parameter value	Corresponding function														
<b>0202</b>	COD1_APPUL_G	Code of the first pulse on key G.	0 -> FFFF FFFF	Hexadecimal code of the instruction generated by the first pulse on key G, in adjust and programming mode. <table border="1" data-bbox="1129 357 1598 617"> <thead> <tr> <th>Instruction</th> <th>Hexadecimal code *</th> </tr> </thead> <tbody> <tr> <td>ACT xx</td> <td>A000 hhhh</td> </tr> <tr> <td>OUT xx</td> <td>A001 hhhh</td> </tr> <tr> <td>IN xx</td> <td>A002 hhhh</td> </tr> <tr> <td>IN/ xx</td> <td>A003 hhhh</td> </tr> <tr> <td>SET OUT xx</td> <td>D016 hhhh</td> </tr> <tr> <td>RST OUT xx</td> <td>D018 hhhh</td> </tr> </tbody> </table> <p>* hhhh is the value of xx in hexadecimal.   OUT 20 =&gt; A001 0014</p>	Instruction	Hexadecimal code *	ACT xx	A000 hhhh	OUT xx	A001 hhhh	IN xx	A002 hhhh	IN/ xx	A003 hhhh	SET OUT xx	D016 hhhh	RST OUT xx	D018 hhhh
	Instruction	Hexadecimal code *																
ACT xx	A000 hhhh																	
OUT xx	A001 hhhh																	
IN xx	A002 hhhh																	
IN/ xx	A003 hhhh																	
SET OUT xx	D016 hhhh																	
RST OUT xx	D018 hhhh																	
Default value : 0	Possible value : 0 -> FFFF FFFF	Interaction with other parameters : 200																
<b>0204</b>	COD2_APPUL_G	Code of the second pulse on key G.	0 -> FFFF FFFF	Hexadecimal code of the instruction generated by the 2nd pulse on the key G, only in programming mode.														
	Default value : 0	Possible value : 0 -> FFFF FFFF	Interaction with other parameters : 200															
<b>0206</b>	COD3_APPUL_G	Code of the third pulse on key G.	0 -> FFFF FFFF	Hexadecimal code of the instruction generated by the 3rd pulse on the key G, only in programming mode.														
	Default value : 0	Possible value : 0 -> FFFF FFFF	Interaction with other parameters : 200															
<b>0208</b>	COD4_APPUL_G	Code of the fourth pulse on key G.	0 -> FFFF FFFF	Hexadecimal code of the instruction generated by the 4th pulse on the key G, only in programming mode.														
	Default value : 0	Possible value : 0 -> FFFF FFFF	Interaction with other parameters : 200															

List of the customized keys' parameters

	NB_APPUI_	COD1_APPUI_	COD2_APPUI_	COD3_APPUI_	COD4_APPUI_
G	200	202	204	206	208
SHIFT + G	210	212	214	216	218
H	220	222	224	226	228
SHIFT + H	230	232	234	236	238
O	240	242	244	246	248
SHIFT + O	250	252	254	256	258
P	260	262	264	266	268
SHIFT + P	270	272	274	276	278
W	280	282	284	286	288
SHIFT + W	290	292	294	296	298
X	300	302	304	306	308
SHIFT + X	310	312	314	316	318
Y	320	322	324	326	328
SHIFT + Y	330	332	334	336	338
Z	340	342	344	346	348
SHIFT + Z	350	352	354	356	358

**PREDEFINED ACTIONS**

The predefined actions are used to control the pneumatic movements (bistable movements with 2 controls or part grip circuits with 1 control). Apart from actions 6, 15 and 16, the actions operate in pairs. An action is defined by three parameters : the output number and the two control inputs.

It is now possible to activate monostable movements with 1 or 2 controls as well as bistable movements with 1 or 2 controls. To do this, set the parameters corresponding to the outputs or inputs that are not used to 128.

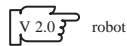

	<b>Bistable action with 2 controls</b>	<b>Bistable action with 1 control</b>	<b>Monostable action with 2 controls</b>	<b>Monostable action with 1 control</b>	<b>Commands for part grip circuit (bistable 2 controls 1 input)</b>	
P_OUT__ACT_A	#	#	#	#	#	
P_IN_ACT_A	#	128	#	#	#	 enter the same values
P_OUT_ACT_B	#	#	128	128	#	
P_IN_ACT_B	#	#	#	128	#	

# represents a numerical value between 0 and 126.

A and B are a pair of actions (for example 17 and 18).

<b>Specific values</b>	<b>Interpretation for the OUT_ACT outputs</b>	<b>Interpretation for the IN_ACT inputs</b>
127		Forced to 0
128	The output has not been allocated a function	Input not controlled

Details of two parameters defining an action :

PARAMETER	Abbreviation	Description	Parameter value	Corresponding function
<b>0370</b>	OUT_ACT_2	Output for action 2	0 → 255	Output number activated by action ACT 2.
	Default value : 128	Possible value : 0 → 255	Interaction with other parameters : 371	
<b>0371</b>	IN_ACT_2	Input for action 2	0 → 255	Input number controlling the end of action ACT 2.
	Parameter 373 contains the number of the input that controls the antagonist movement (input tested at 0 for this action).			
	Default value : 127	Possible value : 0 → 255	Interaction with other parameters : 370	

Parameters 372 to 433 function in the same manner as the two parameters above. They are described in the following pages.



Action	OUT_ parameter	IN_ parameter	/IN parameter	Allocation	
ACT_02	370	371	375	No allocation if TYP_2_BRAS <sub>[37]</sub> = 0	Pneumatic arm 1 up
ACT_04	374	375	371		Pneumatic arm 1 down
ACT_03	372	373	377	No allocation if TYP_2_BRAS <sub>[37]</sub> = 0	Pneumatic arm 2 up
ACT_05	376	377	373		Pneumatic arm 2 down
ACT_06	378	379	–	Reserved action	Pneumatic arm slow approach
ACT_07	380	381	383	No allocation if TYP_2_BRAS <sub>[37]</sub> = 0	Pneumatic arm forward
ACT_08	382	383	381		Pneumatic arm backward
ACT_09	384	385	387	Actions reserved for the rotation 1 command	Gripper horizontal
ACT_10	386	387	385		Gripper vertical
ACT_11	388	389	391	Actions reserved for the part grip	Grip part 1
ACT_12	390	391	389		Release part 1
ACT_13	392	393	395	Actions reserved for the rotation 2 command	Rotation 2 + direction
ACT_14	394	395	393		Rotation 2 – direction
ACT_15	396	397	–	Action reserved	Pneumatic arm down slowly
ACT_16	398	399	401	Actions reserved for the rotation 2 intermediate stop command	Rotation 2 intermed. position
$\overline{\text{ACT}}_{16}$	400	401	399		Antagonist command of ACT_16 (stop in)
ACT_17	402	403	405	Actions not allocated	Command not allocated
ACT_18	404	405	403		Command not allocated

Action	OUT_ parameter	IN_ parameter	/IN parameter	Allocation	
ACT_19	406	407	409	Actions reserved for a part grip	Grip part 2
ACT_20	408	409	407		Release part 2
ACT_21	410	411	413	Actions reserved for a part grip	Grip part 3
ACT_22	412	413	411		Release part 3
ACT_23	414	415	417	Actions reserved for a part grip	Grip part 4
ACT_24	416	417	415		Release part 4
ACT_25	418	419	421	Actions reserved for a part grip	Grip part 5
ACT_26	420	421	419		Release part 5
ACT_27	422	423	425	Actions reserved for a part grip	Grip part 6
ACT_28	424	425	423		Release part 6
ACT_29	426	427	429	Actions reserved for a part grip	Grip part 7
ACT_30	428	429	427		Release part 7
ACT_31	430	431	433	Actions reserved for a part grip	Grip part 8
ACT_32	432	433	431		Release part 8

Note : For the grip – release actions, you must enter the same input number in the IN and /IN parameters : the same input indicates the part presence (input =1) and absence (input = 0).



PARAMETER	Abbreviation	Description	Default value	Function
<b>0447</b>	IN_Y_MACH_1	Y in machine 1 axis	128	Input at 1 if the robot's Y axis is on the machine 1 axis' Y cam.
<b>0448</b>	IN_Y_MACH_2	Y in machine 2 axis	127	Input at 1 if the robot's Y axis is on the machine 2 axis' Y cam.
<b>0449</b>	IN_HORS_MACH 1	Robot outside machine 1	127	Input at 1 if the robot is on the “outside machine 1” cam.
<b>0450</b>	IN_HORS_MACH 2	Robot outside machine 2	128	Input at 1 if the robot is on the “outside machine 2” cam.
<b>0451</b>	IN_ATT_DECAL 1	Offset wait on machine 1 validation	128	Input at 0 if offset wait for machine 1 is selected.
<b>0452</b>	IN_ATT_DECAL 2	Offset wait on machine 2 validation	128	Input at 0 if offset wait for machine 2 is selected.
<b>0453</b>	IN_ACCES_LAT	Lateral access validation	127	Input at 1 if the lateral access is selected.
<b>0454</b>	IN_BRAS_1_HM	Arm 1 outside mould	19	Input at 1 if arm 1 is on the Outside Mould Area (ZHM) cam.
<b>0455</b>	IN_BRAS_2_HM	Arm 2 outside mould	128	Input at 1 if arm 2 is on the Outside Mould Area (ZHM) cam.
<b>0456</b>	IN_BRAS_1_H	Arm 1 up	16	Input at 1 if arm 1 is on the Arm Up (BH) cam.
<b>0457</b>	IN_BRAS_2_H	Arm 2 up	128	Input at 1 if arm 2 is on the Arm Up (BH) cam.



The default value may vary depending on the type of input / output board. Consult the list of robot parameters, file S.

PARAMETER	Abbreviation	Description	Default value	Function
<b>0458</b>	IN_SECU_ROT_1	Rotation safety 1	127	Input at 1 if arm 1 is on the Vertical Rotation obligatory RVO (arm retracted) cam. A fault will be detected if this input is at 1 AND if the gripper head is not vertical (IN_ACT_10 <sub>[387]</sub> = 0).
<b>0459</b>	IN_SECU_ROT_2	Rotation safety 2	128	Input at 1 if arm 1 is on the Horizontal Rotation authorized RHA (arm forward) cam. A fault will be detected if this input is at 0 AND if the gripper head is not vertical (IN_ACT_10 <sub>[387]</sub> = 0).
<b>0460</b>	IN_PROTECT	Robot safeguards OK	1	Input at 1 if the safeguards are closed.
<b>0461</b>	IN_INVALID	Dead man validation button OK	137	Input at 1 if one of the Dead Man buttons is pressed in maintenance mode (key in “safeguard open” position).
<b>0462</b>	IN_DEF_TRANSIST	Brake transistor fault	30	Input at 0 if the vertical axis’ brake transistor is faulty (Brake board).
<b>0463</b>	IN_CTL_PCO_1	Correct operation of end of stroke PCO 1 control	128	Input at 0 if the end of stroke PCO is activated. A fault will be detected if this input is at 0 AND if the ZBD input is at 0 (IN_ZBD <sub>[444]</sub> = 0). If the PCO cam is outside the ZBD cam, enter 128 in this parameter.
<b>0464</b>	IN_CTL_PCO_2	Correct operation of end of stroke PCO 2 control	128	Input at 0 if the end of stroke PCO is activated. A fault will be detected if this input is at 0 AND if the ZBD input is at 0 (IN_ZBD <sub>[444]</sub> = 0). If the PCO cam is outside the ZBD cam, enter 128 in this parameter.
<b>0465</b>	IN_CTL_SBD_1	Correct operation of relay SBD 1 control	3	Input at 1 if the SBD 1 relay is stuck (information coming from the S900II Interface board).
<b>0466</b>	IN_CTL_SBD_2	Correct operation of relay SBD 2 control	128	Input at 1 if the SBD 2 relay is stuck (information coming from the S900II Interface board).



The default value may vary depending on the type of input / output board. Consult the list of robot parameters, file S.

PARAMETER	Abbreviation	Description	Default value	Function
<b>0467</b>	IN_VAR_OK_X	X speed driver control OK	4	Input at 1 if the X axis' speed driver is working (not faulty). If this is the only input connected, enter 128 in parameters 468 to 471. In this case, the fault message will not distinguish the axis with the speedy fault driver.
<b>0468</b>	IN_VAR_OK_Y	Y speed driver control OK	128	Input at 1 if the Y axis' speed driver is working (not faulty).
<b>0469</b>	IN_VAR_OK_Z	Z speed driver control OK	128	Input at 1 if the Z axis' speed driver is working (not faulty).
<b>0470</b>	IN_VAR_OK_B	B speed driver control OK	128	Input at 1 if the B axis' speed driver is working (not faulty).
<b>0471</b>	IN_VAR_OK_C	C speed driver control OK	128	Input at 1 if the C axis' speed driver is working (not faulty).
<b>0472</b>	IN_POWER	Power control OK	5	Input at 1 if the robot is powered up (KM1 relay active).
<b>0473</b>	IN_BAUR_OK	External emergency stop button OK	0	Input at 0 if an external emergency stop is pressed down (robot cabinet, IMM or peripheral units emergency stop).
<b>0474</b>	IN_SURC_X	X axis in overtravel	6	Input at 0 if the X axis is in overtravel. If this is the only input connected, enter 128 in parameters 475 to 478. In this case, the fault message does not distinguish the axis in overtravel.
<b>0475</b>	IN_SURC_Y	Y axis in overtravel	128	Input at 0 if the Y axis is in overtravel.
<b>0476</b>	IN_SURC_Z	Z axis in overtravel	128	Input at 0 if the Z axis is in overtravel.
<b>0477</b>	IN_SURC_B	B axis in overtravel	128	Input at 0 if the B axis is in overtravel.
<b>0478</b>	IN_SURC_C	C axis in overtravel	128	Input at 0 if the C axis is in overtravel.



The default value may vary depending on the type of input / output board. Consult the list of robot parameters, file S.

PARAMETER	Abbreviation	Description	Parameter value	Corresponding function
<b>0480</b>	POS_Z_HM	Z “Arm 1 outside mould” monitoring position. Possible value : 0 -> 999999	999999	Position in 1/10 mm where the Arm 1 outside mould input (IN_BRAS_1_HM <sub>[454]</sub> ) must go to 0 (enter the lowest position of the cam plus about 100 mm).  If the position of the Area Outside Mould cam (ZHM) is very close to the Arm Up (BH) position, it is preferable to enter the same input number (IN_BRAS_1_H <sub>[456]</sub> ) in (IN_BRAS_1_HM <sub>[454]</sub> ).
	Default value : 999999	Possible value : 0 -> 999999	Interaction with other parameters : 454.	
<b>0482</b>	POS_C_HM	C “Arm 2 outside mould” monitoring position. Possible value : 0 -> 999999	0	Position in 1/10 mm where the Arm 2 outside mould input (IN_BRAS_2_HM <sub>[455]</sub> ) must go to 0 (enter the lowest position of the cam plus about 100 mm).  If the position of the Area Outside Mould cam (ZHM) is very close to the Arm Up (BH) position, it is preferable to enter the same input number (IN_BRAS_2_H <sub>[457]</sub> ) in (IN_BRAS_2_HM <sub>[455]</sub> ).
	Default value : 0	Possible value : 0 -> 999999	Interaction with other parameters : 455.	
<b>0484</b>	POS_Y_HM	Y monitoring position of Y in machine 1 axis.	0 -> 999999	Position in 1/10 mm where the input for Y in machine 1 axis (IN_Y_MACH_1 <sub>[447]</sub> ) switches to 0 (enter the start position of the cam plus about 100 mm).  Its coherence can only be controlled for part grip movements in the + direction.
	Default value : 0	Possible value : 0 -> 999999	Interaction with other parameters : 447.	

INTERFACE INPUTS WITH INJECTION MOULDING MACHINE 1				
Possible value :		0 -> 255	Specific values :	127 -> forced to 0 128 -> forced to 1
PARAMETER	Abbreviation	Description	Default value	Function
<b>0490</b>	IN_FIN_MV_NOY_1_1	End of core puller movement 1	10	Input at 1 if IMM 1's core pullers have reached position 1.
<b>0491</b>	IN_FIN_MV_NOY_2_1	End of core puller movement 2	11	Input at 1 if IMM 1's core pullers have reached position 2.
<b>0492</b>	IN_EJECT_OUT1	Ejectors out	9	Input at 1 if IMM 1's ejectors are out.
<b>0493</b>	IN_EJECT_IN_1	Ejectors in	8	Input at 1 if IMM 1's ejectors are in.
<b>0494</b>	IN_FIN_OUVERT_1	Mould open	7	Input at 1 if IMM 1's mould is completely open.
<b>0495</b>	IN_PIECE_FAB_1	Mould closed	14	Input at 1 if IMM 1's mould is closed.
<b>0496</b>	IN_PORTE_CLOSE_1	Gate closed	128	Input at 1 if IMM 1's gate is closed.
<b>0497</b>	IN_OUV_PARTIELLE_1	Partial opening reached	15	Input at 1 if IMM 1's mould is partially open (descent is authorized).
<b>0498</b>	IN_AUTO_MACH_1	Machine in Automatic or Semi-Automatic	13	Input at 1 if IMM 1 is in automatic or semi-automatic.
<b>0499</b>	IN_CTL_RELANCE_1	Anticipated restart control input	127	Input at 1 if the anticipated restart's monitoring circuit is active. If this is the case, the D_35: ANTICIPATED RESTART NOT CONFORM fault appears on the screen. To reactivate the monitoring circuit, power down the robot cabinet.



The default value may vary depending on the type of input / output board. Consult the list of robot parameters, file S.



<b>INTERFACE INPUTS WITH INJECTION MOULDING MACHINE 2</b>
---

<b>Possible value :</b>	<b>0 -&gt; 255</b>	<b>Specific value :</b>	<b>127 -&gt; forced to 0</b> <b>128 -&gt; forced to 1</b>
-------------------------	--------------------	-------------------------	--

PARAMETER	Abbreviation	Description	Default value	Function
<b>0500</b>	IN_FIN_MV_NOY_1_2	End of core puller movement 1	127	Input at 1 if IMM 2's core pullers have reached position 1.
<b>0501</b>	IN_FIN_MV_NOY_2_2	End of core puller movement 2	127	Input at 1 if IMM 2's core pullers have reached position 2.
<b>0502</b>	IN_EJECT_OUT2	Ejectors out	127	Input at 1 if IMM 2's ejectors are out.
<b>0503</b>	IN_EJECT_IN_2	Ejectors in	127	Input at 1 if IMM 2's ejectors are in.



The default value may vary depending on the type of input / output board. Consult the list of robot parameters, file S.

<b>EXTERNAL COMMAND INPUTS</b>
--------------------------------

<b>Possible value :</b>	<b>0 -&gt; 255</b>	<b>Specific values :</b>	<b>127 -&gt; forced to 0</b> <b>128 -&gt; forced to 1</b>
-------------------------	--------------------	--------------------------	--

PARAMETER	Abbreviation	Description	Default value	Function
<b>0510</b>	IN_VAL_CDE_EXT	External command validation	127	Input at 1 to authorize the external commands. Enables operation without the pendant.
<b>0511</b>	IN_VAL_CH_PRG	Program change validation	127	Input at 1 to validate the program change.

PARAMETER	Abbreviation	Description	Default value	Function
<b>0512</b>	IN_SUSCYC	Cycle suspension	128	Input at 0 to request the cycle suspension.
<b>0513</b>	IN_START_CYC1	Start BRP 1	127	Input at 1 if the Start button of the IMM 1 restart box (BRP 1) is pressed.
<b>0514</b>	IN_RST_MEM_PIEC_1	Reset BRP 1	127	Input at 1 if the Reset button of the IMM 1 restart box (BRP 1) is pressed.
<b>0515</b>	IN_WRK_SS_ROB_1	Without robot BRP 1 and robot OFF	31	Input at 1 if the Without robot button of the IMM 1 restart box (BRP 1) is pressed or if the Robot OFF switch is in the Robot OFF position.
<b>0516</b>	IN_START_CYC2	Start BRP 2	127	Input at 1 if the Start button of the IMM 2 restart box (BRP 2) is pressed.
<b>0517</b>	IN_RST_MEM_PIEC_2	Reset BRP 2	127	Input at 1 if the Reset button of the IMM 2 restart box (BRP 2) is pressed.
<b>0518</b>	IN_WRK_SS_ROB_2	Without robot BRP 2	31	Input at 1 if the Without robot button of the IMM 2 restart box (BRP 2) is pressed.
<b>0519</b>	IN_END_CYC	End of cycle request	128	Input at 0 for an end of cycle request.  For IMM integrated commands (parameter 1=3), the end of cycle input must be at 1 to trigger a stop at end of cycle.
<b>0520</b>	IN_PCO	Tool Change Position request	127	Input at 1 for a Tool Change Position request (PCO).
<b>0521</b>	IN_RO_SIMPLE	Simple home return request	127	Input at 1 for a simple home return request (RO).
<b>0522</b>	IN_RO_TOTAL	Total home return request	127	Input at 1 for a total home return request.



The default value may vary depending on the type of input / output board. Consult the list of robot parameters, file S.

PARAMETER	Abbreviation	Description	Default value	Function
<b>0523</b>	IN_VER_MOD	Mode locking	127	Input at 1 to lock the robot's operating modes.
<b>0524</b>	IN_VER_PRG	Programming mode locking	127	Input at 1 to lock the programming mode.
<b>0525</b>	IN_REGLAGE	Adjust mode	127	Input at 1 to select the Adjust mode.
<b>0526</b>	IN_PAS_A_PAS	Step by Step mode	127	Input at 1 to select the Step by Step mode.
<b>0527</b>	IN_AUTO	Automatic mode	127	Input at 1 to select the Automatic mode.

Note : If more than one of the 3 inputs of parameters 525, 526 and 527 are at 1, the robot goes into STOP mode.

<b>0548</b>	IN_STOP	Immediate stop	127	Input at 1 to request the immediate stop of the robot.
-------------	---------	----------------	-----	--

<b>0528</b>	IN_X_PLUS	X+ command	127	Input at 1 to request an X+ movement.
<b>0529</b>	IN_X_MOINS	X- command	127	Input at 1 to request an X- movement.
<b>0530</b>	IN_Y_PLUS	Y+ command	127	Input at 1 to request a Y+ movement.
<b>0531</b>	IN_Y_MOINS	Y- command	127	Input at 1 to request a Y- movement.



The default value may vary depending on the type of input / output board. Consult the list of robot parameters, file S.

PARAMETER	Abbreviation	Description	Default value	Function
<b>0532</b>	IN_Z_PLUS	Z+ command	127	Input at 1 to request a Z+ movement.
<b>0533</b>	IN_Z_MOINS	Z– command	127	Input at 1 to request a Z– movement.
<b>0534</b>	IN_B_PLUS	B+ command	127	Input at 1 to request a B+ movement.
<b>0535</b>	IN_B_MOINS	B– command	127	Input at 1 to request a B– movement.
<b>0536</b>	IN_C_PLUS	C+ command	127	Input at 1 to request a C+ movement.
<b>0537</b>	IN_C_MOINS	C– command	127	Input at 1 to request a C– movement.
<b>0538</b>	IN_V_PLUS	Overall speed increase	127	Input at 1 to request an increase in overall speed.
<b>0539</b>	IN_V_MOINS	Overall speed decrease	127	Input at 1 to request a decrease in overall speed.



The default value may vary depending on the type of input / output board. Consult the list of robot parameters, file S.

PROGRAM NUMBER ENCODING INPUTS				
Possible value :		0 -> 255	Specific values :	
			127 -> forced to 0 128 -> forced to 1	
PARAMETER	Abbreviation	Description	Default value	Function
<b>0540</b>	IN_COD_PRG_1	Program code weight 1	127	Input at 1 if the weight 1 bit of the coded program number is at 1
<b>0541</b>	IN_COD_PRG_2	Program code weight 2	127	Input at 1 if the weight 2 bit of the coded program number is at 1
<b>0542</b>	IN_COD_PRG_4	Program code weight 4	127	Input at 1 if the weight 4 bit of the coded program number is at 1
<b>0543</b>	IN_COD_PRG_8	Program code weight 8	127	Input at 1 if the weight 8 bit of the coded program number is at 1
<b>0544</b>	IN_COD_PRG_16	Program code weight 16	127	Input at 1 if the weight 16 bit of the coded program number is at 1
<b>0545</b>	IN_COD_PRG_32	Program code weight 32	127	Input at 1 if the weight 32 bit of the coded program number is at 1
<b>0546</b>	IN_COD_PRG_64	Program code weight 64	127	Input at 1 if the weight 64 bit of the coded program number is at 1
<b>0547</b>	IN_PARITE	Program code parity	127	Input at 1 so that an even number of inputs in the code are at 1

See encoding example page 7.



The default value may vary depending on the type of input / output board. Consult the list of robot parameters, file S.

**0548** See description page 48.

SAFETY OUTPUTS					
Possible value :		0 -> 255		Specific values :	128 -> output not used
PARAMETER	Abbreviation	Description	Default value	Function	
<b>0550</b>	OUT_FORC_SURC	Overtravel forced	3	Output at 1 to force the overtravels on the S900–II Interface board. This output goes to 1 when  is pressed in adjust mode.	
<b>0551</b>	OUT_SUIVI_OK	Following axis OK	128	Output at 1 to indicate that the following axis functions correctly.	
<b>0552</b>	OUT_DEF_ROB	Robot in fault	1	Output at 0 to indicate that the robot is in fault mode.	
<b>0553</b>	OUT_ALARM	Visual alarm	0	Output at 1 to light up the orange luminous column on top of the cabinet.	
<b>0554</b>	OUT_START_ALARM	Starting siren	128	Output at 1 to activate the restart siren (128 = no delayed start).	



The default value may vary depending on the type of input / output board. Consult the list of robot parameters, file S.

**OUTPUTS SHOWING THE ROBOT'S STATUS**

**Possible value :**        **0 -> 255**                      **Specific values :**        **128 -> output not used**

These outputs are only activated if parameter 12 (CP\_STAT\_ROB) is at 1.

PARAMETER	Abbreviation	Description	Default value	Function
<b>0560</b>	OUT_EN_CYC	Robot in cycle	128	Output at 1 when the robot is in cycle.
<b>0561</b>	OUT_EN_ARRET	Robot stopped	128	Output at 1 when the robot is stopped.
<b>0562</b>	OUT_EN_FIN_CYC	End of robot cycle running	128	Output at 1 when the robot is running its end of cycle.
<b>0563</b>	OUT_EN_PCO	Moving to Tool Change Position	128	Output at 1 when the robot is moving to its Tool Change Position.
<b>0564*</b>	OUT_EN_RO_SIMP	Simple home return in progress	128	Output at 1 when the robot is in a simple home return.
<b>0565</b>	OUT_EN_RO_TOT	Total home return in progress	128	Output at 1 when the robot is in a total home return.
<b>0566</b>	OUT_EN_REGL	Robot in Adjust mode	128	Output at 1 when the robot is in Adjust mode.
<b>0567*</b>	OUT_EN_STEP	Robot in Step by Step mode	128	Output at 1 when the robot is in Step by Step mode.
<b>0568*</b>	OUT_EN_AUTO	Robot in Automatic mode	128	Output at 1 when the robot is in Automatic mode.



The default value may vary depending on the type of input / output board. Consult the list of robot parameters, file S.

\* Outputs activated when the IMM integrated commands are in operation (parameter 1=3).

INTERFACE OUTPUTS FOR IMM 1					
Possible value :		0 -> 255		Specific values :	128 -> output not used
PARAMETER	Abbreviation	Description	Default value	Function	
<b>0570</b>	OUT_MOD_SS_ROB_1	Without robot and/or Robot OFF mode IMM 1	17	Output at 1 when the without robot and/or Robot OFF mode is selected for IMM 1.	
<b>0571</b>	OUT_ALARM_BRI	Alarm signal on BRP 1	1	Output at 1 when the the alarm signal is lit up on the IMM 1 restart box (BRP 1).	
<b>0572</b>	OUT_SBD_1	Arm Free IMM 1 safety device	16	Output at 1 when the robot's arm is free of IMM 1.	
<b>0573</b>	OUT_VAL_CYC1	Machine Cycle Validation (VCM) IMM 1	20	Output at 1 when the robot validates the IMM 1 machine cycle.	
<b>0574</b>	OUT_VAL_FIN_OUV_1	End of Opening validation (VFO) IMM 1	23	Output at 1 when the robot validates the end of the mould opening for IMM 1.	
<b>0575</b>	OUT_VAL_OUT_EJECT_1	Ejectors out validation (VSEJ) IMM 1	22	Output at 1 when the robot validates the ejectors out for IMM 1.	
<b>0576</b>	OUT_VAL_IN_EJECT_1	Ejectors in validation (VREJ) IMM 1	21	Output at 1 when the robot validates the ejectors in for IMM 1.	
<b>0577</b>	OUT_CMD_NOY_1_1	Core puller movement 1 validation, IMM 1	18	Output at 1 when the robot validates the core puller movement to position 1 for IMM 1.	
<b>0578</b>	OUT_CMD_NOY_2_1	Core puller movement 2 validation, IMM 1	19	Output at 1 when the robot validates the core puller movement to position 2 for IMM 1.	





The default value may vary depending on the type of input / output board. Consult the list of robot parameters, file S.





**INTERFACE OUTPUTS FOR IMM 2**
**Possible value :** 0 -> 255      **Specific values :** 128 -> output not used

PARAMETER	Abbreviation	Description	Default value	Function
<b>0579</b>	OUT_MOD_SS_ROB_2	Without robot mode and/or Robot OFF IMM 2	128	Output at 1 when the without robot mode and/or Robot OFF is selected for IMM 2.
<b>0584</b>	OUT_VAL_OUT_EJECT_2	Ejectors out validation (VSEJ) IMM 2	128	Output at 1 when the robot validates the ejectors out for IMM 2.
<b>0585</b>	OUT_VAL_IN_EJECT_2	Ejectors in validation (VREJ) IMM 2	128	Output at 1 when the robot validates the ejectors in for IMM 2.
<b>0586</b>	OUT_CMD_NOY_1_2	Core puller movement 1 validation, IMM 2	128	Output at 1 when the robot validates the core puller movement to position 1 for IMM 2.
<b>0587</b>	OUT_CMD_NOY_2_2	Core puller movement 2 validation, IMM 2	128	Output at 1 when the robot validates the core puller movement to position 2 for IMM 2.



The default value may vary depending on the type of input / output board. Consult the list of robot parameters, file S.



**PNEUMATIC HIGH SPEED OUTPUTS**
**Possible value :** 0 -> 225      **Specific values :** 128 -> output not used

PARAMETER	Abbreviation	Description	Default value	Function
<b>0590</b>	OUT_GV_UD_1	Cylinder 1 high speed ascent and descent	128	Output at 1 to validate the high speed ascent and descent for cylinder 1.
<b>0591</b>	OUT_GV_UD_2	Cylinder 2 high speed ascent and descent	128	Output at 1 to validate the high speed ascent and descent for cylinder 2.
<b>0592</b>	OUT_GV_AV_REC	High speed advance and retreat	128	Output at 1 to validate the high speed advance and retreat.

## I – 2. Axes' parameters

The parameters greater than 600 characterize the S900–II numeric axes. These parameters can only be changed by people who have followed a Sepro robotique specific training course. Consult our After Sales Service for any other characteristic changes.

However, you may need to change the value of certain axes' parameters, for example, the minimum and maximum limits for the axes' movements. In fact, if the robot's environment changes, you may need to increase or decrease the axes' stroke. The corresponding parameters are described in the following tables.

PARAMETER	Abbreviation	Description	Parameter value	Corresponding function
<b>0646</b> <b>0782</b> <b>0918</b> <b>1054</b> <b>1190</b>	LIMAX_X	Maximum limit for movement in 1/10 mm	1 -> 999999	Value of the axis' maximum limit.
	LIMAX_Y			
	LIMAX_Z			
	LIMAX_B			
	LIMAX_C			
	Default value : 999999			
<b>0648</b> <b>0784</b> <b>0920</b> <b>1056</b> <b>1192</b>	LIMIN_X	Minimum limit for movement in 1/10 mm	1 -> 999999	Value of the axis' minimum limit.
	LIMIN_Y			
	LIMIN_Z			
	LIMIN_B			
	LIMIN_C			
	Default value : 1			

### **I – 3. Saving and recovering the parameters**

It is possible to transfer the robot's parameters to the PC and vice versa or onto a diskette if the robot is equipped with the “floppy disk drive” option.

#### ► PC

The parameters are saved and recovered using the Sepro AS900–II software. The use of this software is described in the on–line Help.

To save the parameters (robot → PC), the robot must be out of programming mode.

To recover the parameters (PC → robot), the robot must be out of programming mode and stopped.

1. “Select” or “Create” the robot if it does not exist.

#### **Saving (Robot → PC)**

2. In the “Communication” menu, choose “Read in a robot”.
3. In the file type, choose “Parameters”
4. At the end of the transfer, “Save the current file”.

#### **Recovering (PC → Robot)**

2. “Select a file”.
3. Choose “Parameters”
4. In the “Communication” menu, choose “Write in the robot”.
5. Enter the password (1234, if it has not been changed).
6. At the end of the transfer, power down the cabinet, then power up again so that the robot takes the new parameters into account.

#### ► Floppy disk drive (option)

The use of the floppy disk drive is described in the “S900–II User Manual”.

## II – PROCESSING THE MATERIAL SAFETY DEVICES

This chapter deals with a PIP vertical unloading robot. The other cases (side–entry and mixed unloading) are dealt with in a specific manual.

### Annotations used :

- IN\_BRAS\_1\_H<sub>[456]</sub> represents parameter number 456 which contains the Arm 1 Up Input number. This term is “ true” when this input is at “ 1 ”.
- / IN\_BRAS\_1\_H<sub>[456]</sub> represents parameter number 456 which contains the Arm 1 Up Input number. This term is “true” when this input is at “0”.
- In the equations, the “ . ” represents the logic AND , and the “ + ” represents the logic OR.

### Controlling the robot’s position :

► If MVT\_OK = 0, the power drops and the D\_5 : MOVEMENT OUTSIDE CAMS fault appears on the screen.

- If the robot is in ADJUST mode :

$$\text{MVT\_OK} = \text{IN\_ATT\_DECAL\_1}_{[451]} + \text{IN\_FIN\_OUVERT\_1}_{[494]} + \text{OUT\_FORC\_SURC}_{[550]} + \text{IN\_ZBD}_{[444]} + (\text{IN\_HORS\_MACH\_1}_{[449]} \cdot \mathbf{V\_BH})$$

- If the robot is not in ADJUST mode :

$$\begin{aligned} \text{MVT\_OK} = & \text{IN\_ZBD}_{[444]} \\ & + (\text{IN\_HORS\_MACH\_1}_{[449]} \cdot \mathbf{V\_BH}) \\ & + (\mathbf{V\_BH} \cdot \text{IN\_FIN\_OUVERT\_1}_{[494]}) \\ & + [ \text{IN\_X\_MACH\_1}_{[445]} \cdot [ (\mathbf{V\_BHM} \cdot \text{IN\_Y\_MACH\_1}_{[447]}) + \text{IN\_FIN\_OUVERT\_1}_{[494]} ] \cdot [ \text{IN\_ATT\_DECAL\_1}_{[451]} + \text{IN\_FIN\_OUVERT\_1}_{[494]} ] ] \end{aligned}$$

Type of second arm : TYP_B_2 <sub>[37]</sub>	Arm Up variable : V_BH	Arm out of Mould variable : V_BHM
0 ( none )	IN_BRAS_1_H <sub>[456]</sub>	IN_BRAS_1_HM <sub>[454]</sub>
1 ( electric )	IN_BRAS_1_H <sub>[456]</sub> · IN_BRAS_2_H <sub>[457]</sub>	IN_BRAS_1_HM <sub>[454]</sub> · IN_BRAS_2_HM <sub>[455]</sub>
2 (pneumatic with stops)	IN_BRAS_1_H <sub>[456]</sub> · IN_ACT_2 <sub>[371]</sub>	IN_BRAS_1_HM <sub>[454]</sub> · (IN_BRAS_2_HM <sub>[455]</sub> + IN_ACT_2 <sub>[371]</sub> )
3 (tandem pneumatic)	IN_BRAS_1_H <sub>[456]</sub> · IN_ACT_2 <sub>[371]</sub> · IN_ACT_3 <sub>[373]</sub>	IN_BRAS_1_HM <sub>[454]</sub> · IN_ACT_2 <sub>[371]</sub> · IN_ACT_3 <sub>[373]</sub>

► If ROT\_1\_OK = 0, the power drops and the D\_15 : ROTATION 1 POSITION INCORRECT fault appears on the screen.

$$\text{ROT\_1\_OK} = [/\text{IN\_ACT\_10}_{[387]} \cdot (\text{IN\_SECU\_ROT\_1}_{[458]} + /\text{IN\_SECU\_ROT\_2}_{[459]})] \cdot /\text{OUT\_FORC\_SURC}_{[550]}$$

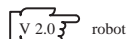
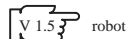

**Calculating the Arm Free Safety device : SBD**

$$\text{SBD} = \text{/Def capt} \cdot \left[ \left[ \text{IN\_ATT\_DECAL\_1}_{[451]} \cdot \left( \text{V\_BHM} \cdot \text{IN\_Y\_MACH\_1}_{[447]} \right) + \left( \text{ANTICIP} \cdot \text{/Déf\_PRESSE} \right) \right] \right. \\ \left. + \text{IN\_ZBD}_{[444]} \right. \\ \left. + \left( \text{IN\_HORS\_MACH\_1}_{[449]} \cdot \text{V\_BH} \right) \right]$$

ANTICIP = anticipated restart running.

Déf\_PRESSE = IMM signal coherence detection.

Def capt = Sensor fault = X sensor coherence+ Z sensor coherence except Déf. B1H and Déf. B2H + SBD relay control.

**Checking the coherence of the sensor information :**

A fault extension number (xx) D\_3 : SENSORS NOT COHERENT . . . . xx enables you to identify the type of fault.

► Arm 1 = Electric : The following checks trigger the fault : D\_3 : SENSORS NOT COHERENT . . . . xx.

Déf\_B1\_HM = IN\_BRAS\_1\_HM<sub>[454]</sub> . position Z > POS\_Z\_HM<sub>[480]</sub> **1**

Déf\_B1\_H = IN\_BRAS\_1\_H<sub>[456]</sub> . /IN\_BRAS\_1\_HM<sub>[454]</sub> . . . . . **2**

► Arm 2 : The following checks trigger the fault : D\_3 : SENSORS NOT COHERENT . . . . xx.

▪ *Arm 2 electric* (TYP\_B\_2<sub>[37]</sub> = 1)

Déf\_B2\_HM = IN\_BRAS\_2\_HM<sub>[455]</sub> . position C > POS\_C\_HM<sub>[482]</sub> **3**

Déf\_B2\_H = IN\_BRAS\_2\_H<sub>[457]</sub> . /IN\_BRAS\_2\_HM<sub>[455]</sub> . . . . . **4**

▪ *Arm 2 pneumatic with stops* (TYP\_B\_2<sub>[37]</sub> = 2)

Déf\_B2\_HM = IN\_BRAS\_2\_HM<sub>[455]</sub> . IN\_ACT\_4<sub>[375]</sub> . . . . . **3**

Déf\_B2 = IN\_ACT\_2<sub>[371]</sub> . IN\_ACT\_4<sub>[375]</sub> . . . . . **5**

▪ *Arm 2 tandem pneumatic* (TYP\_B\_2<sub>[37]</sub> = 3)

Déf\_V1\_BH = IN\_ACT\_2<sub>[371]</sub> . IN\_ACT\_4<sub>[375]</sub> . . . . . **6**

(cylinder 1 fault, up and down not possible at the same time)

Déf\_V2\_BH = IN\_ACT\_3<sub>[373]</sub> . IN\_ACT\_5<sub>[377]</sub> . . . . . **7**

(cylinder 2 fault, up and down not possible at the same time)

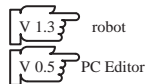

► X axis : The following check triggers the fault : D\_3 : SENSORS NOT COHERENT . . . . .xx.

**Déf\_capt\_X** = (IN\_ZBD<sub>[444]</sub> . IN\_X\_MACH\_1<sub>[445]</sub>) + (IN\_HORS\_MACH\_1<sub>[449]</sub> . IN\_X\_MACH\_1<sub>[445]</sub>) . . . . . **13**

**Déf\_capt\_Y** = (IN\_Y\_MACH\_1<sub>[447]</sub> . position Y > POS\_Y\_HM<sub>[484]</sub>) . . . . . **17**

► PCO sensor : The following check triggers the fault : D\_3 : SENSORS NOT COHERENT . . . . .xx.

This check is only valid if the PCO cam is in the ZBD area, otherwise set the parameter to : IN\_CTL\_PCO\_1<sub>[463]</sub> = 128

**Déf\_PCO1** = /IN\_ZBD<sub>[444]</sub> . /IN\_CTL\_PCO\_1<sub>[463]</sub> . /OUT\_FORC\_SURC<sub>[550]</sub> . . . . . **14**

► Mould : The following check triggers the fault : D\_3 : SENSORS NOT COHERENT . . . . .xx.

**Déf\_Moule** = IN\_PIECE\_FAB\_1<sub>[495]</sub> . (IN\_OUV\_PARTIELLE\_1<sub>[497]</sub> + IN\_FIN\_OUVERT<sub>[494]</sub>) . . . . . **16**

► SBD relay control : The following check triggers the fault “D\_4 : SAFETY RELAY FAULT”.

**Déf\_SBD1** = /OUT\_FORC\_SURC<sub>[550]</sub> . IN\_CTL\_SBD\_1<sub>[465]</sub>

► Command transistor for the Z axis’ brake : The following check triggers the fault “D\_52 : BRAKE COMMAND FAULTY “.

**Déf\_frein\_Z** = /IN\_DEF\_TRANSIST<sub>[462]</sub> . /OUT\_FORC\_SURC<sub>[550]</sub> . (IN\_PORTE\_CLOSE\_1<sub>[496]</sub> + IN\_ZBD<sub>[444]</sub>)

► IMM gate control (outside of the emergency stop line) : The following check triggers the fault “Machine gate open.”  
or “D\_5 : MOVEMENT OUTSIDE CAMS” or “D\_33 : GATE OPEN SIGNAL LOST”.

**Déf\_porte** = /IN\_ZBD<sub>[444]</sub> . /IN\_MOD\_MAINT<sub>[441]</sub> . (/IN\_PORTE\_CLOSE\_1<sub>[496]</sub> . (REGLAGE + (EN\_CYCLE . (/VALIDATION CYCLE MACHINE +  
(VALIDATION CYCLE MACHINE . IN\_PIECE\_FAB\_1<sub>[495]</sub>))))))

EN\_CYCLE = robot in automatic cycle.

VALIDATION CYCLE MACHINE = robot in Await Machine Cycle.

REGLAGE = adjust mode active.

# III – HARDWARE ARCHITECTURE

## III – 1. S900–II general block diagram (for a brushless axis)

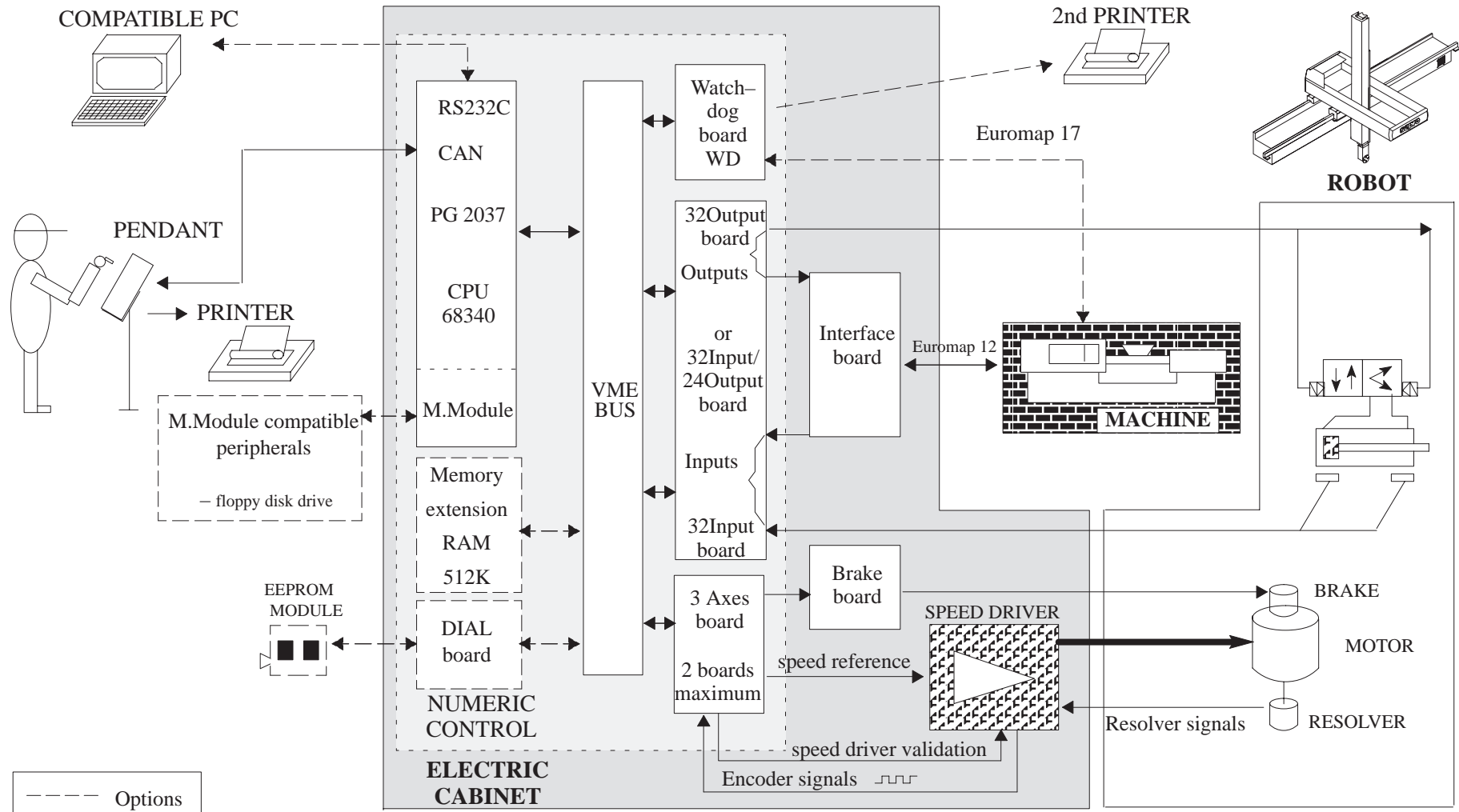

### III – 2. The S900-II numeric control system

This is made up of a “double europe” format rack which contains the electronic boards. The inter-board dialogue is assured by a VME bus.

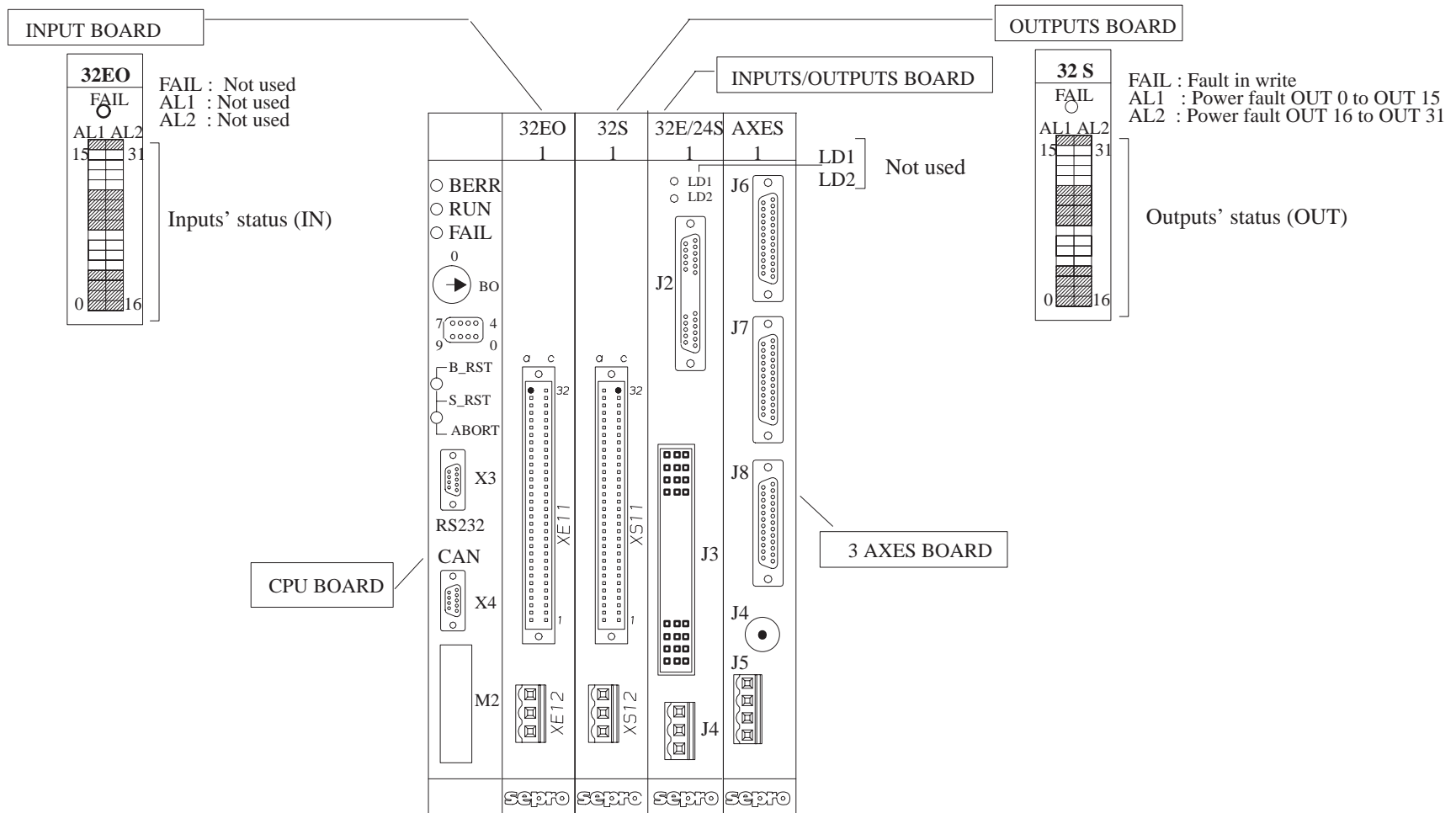



III – 3. The control cabinet boards

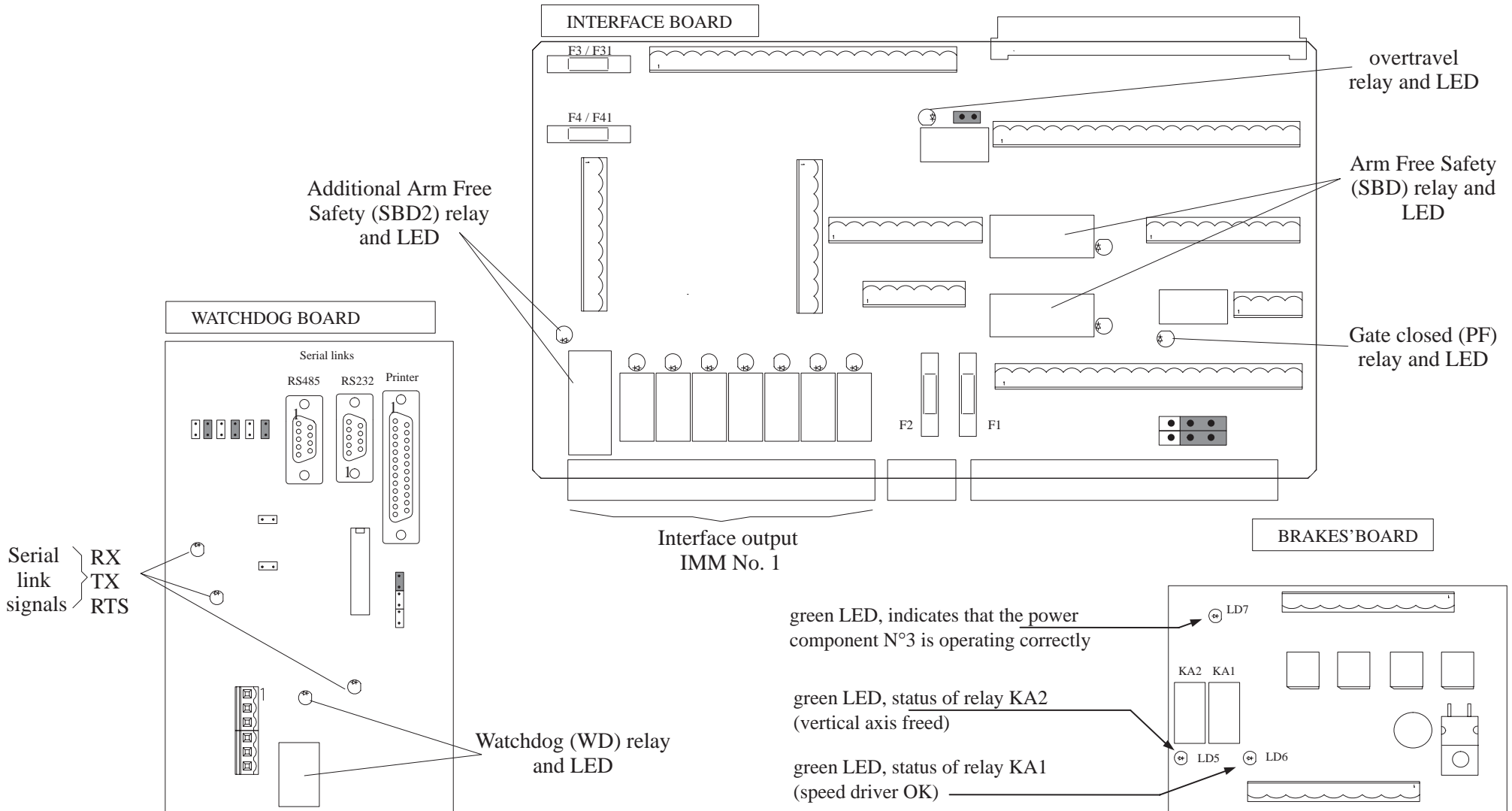

## IV – FAULT LIST

D\_1 : NO POWER

D\_2 : \$ -SPEED DRIVER FAULT

Reset the driver fault once it has been identified

D\_3 : SENSORS NOT COHERENT.....xx

Check....: I\_ , I\_ , I\_ , I\_

D\_4 : SAFETY RELAY FAULT

The <SBD> relay is not working properly

D\_5 : MOVEMENT OUTSIDE CAMS

Select ADJUST MODE to bring the robot back to an authorized area.

D\_6 : FAL SAFETY DEVICE

Remove gripper from release area and check position of FAL

D\_7 : PROTECTED MOVEMENT.....\$\$

The conditions necessary for the movement are not present

D\_8 : INCORRECT AIR PRESSURE

Pneumatic supply faulty or bad pressure sensor adjustment

D\_9 : WATCHDOG RELAY FAULTY

CPU watchdog or its relay are not working properly

D\_10

Safety time between steps elapsed  
Input(s) or Bit(s) test fault

D\_11: INCORRECT PRG NUMBER CODE

Check the PRG number encoding and the parity wire

D\_12: INPUT MODULO \$ FAULTY !

Access to Inputs Modulo(16) impossible

D\_13: OUTPUT FAILURE.....

Output(s) short-circuited or over temperature limit

D\_14: DIVISION BY 0

Check axis parameter value

D\_15: ROTATION 1 POSITION INCORRECT

The gripper head must be vertical in this area. Check your PRG

D\_16: MAINTENANCE SELECTOR FAULTY

Check....: I\_ , I\_ , I\_ , I\_

D\_17: PENDANT NOT IN ITS SUPPORT

Automatic mode is prohibited when the pendant is not in its support

D\_20: PC LINK FAULTY

Check the Robot/PC link as well as the transmission speed

D\_21: E17 LINK FAULTY  
Check the Robot/IMM link as well as  
the transmission speed

D\_22: CAN LINK FAULTY  
Check the Robot/displaced I/O link  
as well as the parameters

D\_27: BAD WRITE IN FLASHPROM  
Repeat the command. Change the CPU  
if here is still an error

D\_30: PART GRIP FAULT.....\$  
Part not correctly gripped after  
time-out programmed in parameter 8

D\_31: PART LOST IN MOULD  
Part lost. Execute a Home return  
before restarting AUTOMATIC cycle.

D\_32: PREMATURE MACHINE RESTART  
Check the programming or the value  
of the parameters 175,176

D\_33: GATE OPEN SIGNAL LOST  
Check. If its normal, once gate  
is closed, press START

D\_34: MOULD OPEN SIGNAL LOST  
Free robot arm in  
ADJUST mode

D\_35: ANTICIPATED RESTART NOT CONFORM  
Check the parameters, then power  
down to cancel the fault

D\_40: AXIS board.\$ FAULTY.....Nr = \$\$  
Check the plugging, components  
and addressing of the axes board

D\_41: AXI(e)S NOT INITIALIZED  
One or more axes are not initialized.  
Select ADJUST mode to initialize

D\_42: \$ -NO AXES BOARD  
Axis declared in parameter without  
an axes driver board ?

D\_43: \$ -TRACKING ERROR TOO LARGE  
Driver badly adjusted or position  
information fault related to encoder

D\_44: \$ -AXIS BLOCKED  
Check brake, brake supply or  
speed reference connection

D\_45: \$ -OVER SPEED LIMIT  
Check motor/speed driver wiring  
and division of speed reference

D\_46: \$ -MVT IN REVERSE DIRECTION  
Check speed driver and parameter  
configuration

D\_47: \$ -COUNTING ERROR  
Check initialization cam and signals  
from pulse generator

D\_48: \$ -PFC PARAMETERS INCOHERENT  
Incoherent value attached to PFC  
parameters. Check

D\_49: \$ -TRIGGERED Mvt. NOT FINISHED  
The previous movement set in motion  
before control point is not finished

D\_50: \$ -POSITION OUTSIDE LIMITS  
The calculated position of the axis  
concerned lies outside the limits.

D\_51: \$ -REGULATION FAULT  
Check the driver and axes board  
offset

D\_52: BRAKE COMMAND FAULTY  
Check the command transistors of axes  
led by their weight.

D\_53: ADC \$ ABSENT OR FAULTY  
The ADC converter is either absent  
or faulty.

D\_54: AXES PARAMETERS INCOHERENT

D\_59: \$ -> E17 MOVEMENT NOT VALUED  
IMM doesn't reply in time delay or  
Euromap 17 option absent

D\_60: \$ -MVT NOT AUTHORISED  
This instruction is not allowed.  
Check the program and/or parameters

D\_61: \$ -MVT IN PRG AND SPP  
SAME motions to be executed  
SIMULTANEOUSLY in PRG and SPP !.

D\_62: \$ -MOVEMENT NOT MOTORISED  
The axis requested is declared  
not MOTORISED in the parameters

D\_63: \$ -MVT TO BE MADE OUTSIDE LIMITS  
The position requested is outside  
the limits set in the parameters

D\_64: TEACHING IMPOSSIBLE  
B / C.STK mvt outside GENERAL STACKING  
or SAP message not present

D\_65: PRG \$\$ NOT FOUND  
This program does not exist.  
Check the program number

D\_66: CODE : 0x\$\$\$\$ NOT CONFORM  
Code not conform  
Check. Repeat [ N° ] if necessary

D\_67: OPERAND :                   INVALID  
Unknown operand. Check contents  
of faulty step.

D\_68: RETURN ADDRESS NOT FOUND !  
Return address not found.  
Check that the return LABEL exists

D\_69  
The info to be controlled during  
the movement is faulty

D\_70: PROGRAM NOT CONFORM  
Bad save copy in MEMORY. Correct by  
using Memory Read procedure

Check the wiring of the motor and  
the movement order

Pendant emergency stop pressed in.

D\_71: WRONG PLC PROGRAM  
Incorrect PLC program. Check  
instructions OR repeat [ N° ] command

Pendant not in its holder.

Validation button released.

D\_72: MORE THAN 16 SUCCESSIVE IFs  
The successive IF instructions in PLC  
must not exceed 16.

Safeguard open.

Machine gate open.

D\_73: PARALLEL SP ALREADY RUNNING  
Preceding parallel SP must be  
completed before starting the next one

\$ : axis in overtravel.

Axi(e)s in overtravel.

D\_74: INSTRUCTION AFTER IF NOT VALID  
Within PRG : IF, L, R, MASTER or SLA  
instructions cannot be used after IF

START to power up again

FAULTY

D\_75: MASTER MOVEMENT NOT DECLARED  
CTL.....movements must be preceded by  
the MASTER code.

Restart

Check the list of CAN faults with the  
number marked at the end of the line

D\_76: INSTRUCTION NOT AUTHORISED  
Instruction to be executed is not  
authorised. Check your program.

W\_00: \$ - Braking faulty

D\_77: TOO MANY SP LEVELS (max 3)  
No more than 3 successive SPs  
can be called (max 3 calls)

W\_01: \$ - No init TOP ?

W\_02: \$ - Too many init pulses

External emergency stop pressed in

W\_03: IMM delayed start incorrect

---

Conair has made the largest investment in customer support in the plastics industry. Our service experts are available to help with any problem you might have installing and operating your equipment. Your Conair sales representative also can help analyze the nature of your problem, assuring that it did not result from misapplication or improper use.

## WE'RE HERE TO HELP

To contact Customer Service personnel, call:



## HOW TO CONTACT CUSTOMER SERVICE

**From outside the United States, call: 814-437-6861**

You can commission Conair service personnel to provide on-site service by contacting the Customer Service Department. Standard rates include an on-site hourly rate, with a one-day minimum plus expenses.

### **If you do have a problem, please complete the following checklist before calling Conair:**

- Make sure you have all model, serial and parts list numbers for your particular equipment. Service personnel will need this information to assist you.
- Make sure power is supplied to the equipment.
- Make sure that all connectors and wires within and between loading control and related components have been installed correctly.
- Check the troubleshooting guide of this manual for a solution.
- Thoroughly examine the instruction manual(s) for associated equipment, especially controls. Each manual may have its own troubleshooting guide to help you.
- Check that the equipment has been operated as described in this manual.
- Check accompanying schematic drawings for information on special considerations.

## BEFORE YOU CALL ...

*Additional manuals and prints for your Conair equipment may be ordered through the Customer Service or Parts Departments for a nominal fee.*

---

## EQUIPMENT GUARANTEE

Conair guarantees the machinery and equipment on this order, for a period as defined in the quotation from date of shipment, against defects in material and workmanship under the normal use and service for which it was recommended (except for parts that are typically replaced after normal usage, such as filters, liner plates, etc.). Conair's guarantee is limited to replacing, at our option, the part or parts determined by us to be defective after examination. The customer assumes the cost of transportation of the part or parts to and from the factory.

## PERFORMANCE WARRANTY

Conair warrants that this equipment will perform at or above the ratings stated in specific quotations covering the equipment or as detailed in engineering specifications, provided the equipment is applied, installed, operated and maintained in the recommended manner as outlined in our quotation or specifications.

Should performance not meet warranted levels, Conair at its discretion will exercise one of the following options:

- Inspect the equipment and perform alterations or adjustments to satisfy performance claims. (Charges for such inspections and corrections will be waived unless failure to meet warranty is due to misapplication, improper installation, poor maintenance practices or improper operation.)
- Replace the original equipment with other Conair equipment that will meet original performance claims at no extra cost to the customer.
- Refund the invoiced cost to the customer. Credit is subject to prior notice by the customer at which time a Return Goods Authorization Number (RGA) will be issued by Conair's Service Department. Returned equipment must be well crated and in proper operating condition, including all parts. Returns must be prepaid.

Purchaser must notify Conair in writing of any claim and provide a customer receipt and other evidence that a claim is being made.

## WARRANTY LIMITATIONS

**Except for the Equipment Guarantee and Performance Warranty stated above, Conair disclaims all other warranties with respect to the equipment, express or implied, arising by operation of law, course of dealing, usage of trade or otherwise, including but not limited to the implied warranties of merchantability and fitness for a particular purpose.**