

36" QuietCool Portable Evaporative Cooler Owner's Manual



*Optional Cover for storage protection.
See section 9.0 for details and a
convenient Fax Back Order form.*

This Manual covers all of the following QuietCool Portable Evaporative Coolers.

QC36D1 – *QuietCool 36" Direct Drive 1 Speed*

QC36DVS – *QuietCool 36" Direct Drive Variable Speed (shown above)*

QC36B1 – *QuietCool 36" Belt Drive 1 Speed ½ HP*

QC36B1X – *QuietCool 36" Belt Drive 1 Speed ¾ HP*

QC36B3 – *QuietCool 36" Belt Drive 3 Speed*

QC36B1XHL – *QuietCool 36" Belt Drive 1 Speed ¾ HP – Explosion Proof*

Direct from the manufacturer

QuietCool

Engineered. Efficient. Cooler.

"Amazing!"

File this owner's manual in a safe place for future reference. It contains operating procedures – maintenance procedures – trouble shooting guide – replacement parts guide – order form – and contact information. **You will need this!**

Warnings and Cautions

Read before operating QuietCool Portable Evaporative Cooler

ELECTRICAL

- WARNING** Do not use a 3 prong to 2 prong adapter on the electrical power cord. Use 12 gauge extension cord only.
- WARNING** Do not remove the grounding lug from the electrical power cord plug.
Use only 3 prong, grounded receptacles.
- WARNING** Disconnect the QuietCool Portable Evaporative Cooler from your electrical power source before performing any service action.
- WARNING** Your QuietCool unit must be plugged into a fused or circuit breaker protected 20 Amp, 120 Volt, 60 Hz circuit – unless specifically manufactured for another voltage / frequency configuration. See manufacturer's label on cooler. A ground fault circuit interrupter protected circuit is strongly recommended.
- WARNING** Check your units electric power cord for insulation breaks, cracks or fraying. If any of these conditions are found DO NOT USE. See your distributor for immediate service replacement parts.
- WARNING** Some electric motors require periodic oiling. Check your model for oil fill holes. A couple drops of light oil per year normally will be sufficient. Heavy usage may require additional oil.
- WARNING** To reduce the risk of fire or electrical shock, DO NOT USE with any solid-state speed control device.
- WARNING** To reduce the risk of electrical shock or injury to persons, DO NOT USE cooler in a window.

WATER

- WARNING** Do not connect your QuietCool Portable Evaporative Cooler to any water source where water pressure exceeds 60 p.s.i. If your water source is above 60 p.s.i. you must use a pressure regulator (which can be found at your local hardware store).

QuietCool Portable Evaporative Cooler

Table of Contents

- 1.0 Introduction
 - 1.1 Quick Start
 - 1.2 Operate unit for 2 weeks before adding Evap-O-Matic Tablets
- 2.0 How Evaporative Cooling Works
- 3.0 Unpacking your new QuietCool unit
- 4.0 Set-up your QuietCool unit
 - 4.1 Connecting the electrical supply
 - 4.2 Connecting the water supply
- 5.0 Operating procedures
 - 5.1 Filling the units reservoir with water
 - 5.2 Turn-on pump
 - 5.3 Adjust water flow
 - 5.4 Turn-on Fan
- 6.0 Daily Operating procedures
 - 6.1 Turn-on pump
 - 6.2 Adjust water flow
 - 6.3 Turn-on fan
 - 6.4 Turn-off unit
- 7.0 Maintenance
 - 7.1 Access inside of unit
 - 7.2 Removing the cooling media
 - 7.3 Daily maintenance
 - 7.4 Periodic maintenance
 - 7.5 QuietCool Trouble Shooting Guide
- 8.0 Storage
- 9.0 Accessories
- 10.0 Replacement Parts and – Order form
- 11.0 Wiring Diagrams for all 36” units
- 12.0 Warranty

File this owner’s manual in a safe place for future reference. It contains operating procedures – maintenance procedures – trouble shooting guide – replacement parts guide – order form – and contact information. **You will need this!**

QuietCool Portable Evaporative Cooler

1.0 Introduction

- Your QuietCool was engineered to be the most efficient portable evaporative cooler manufactured. It was manufactured and assembled at our plant in Houston, Texas.
- Your QuietCool was tested 3 ways. Your unit was *tested for* 1. Maximum air flow at operating static pressure. Only QuietCool is *tested in operating conditions* with 2. *Water* and 3. *Electricity* before it is shipped.
- QuietCool is *easy to operate* – needs only tap water and electricity to operate.
- QuietCool is *easy to move* – roll your QuietCool to the area you want to cool. QuietCool comes standard with straight and swivel / lock casters which make moving your QuietCool a breeze.

1.1 **Quick Start** – Your Quick Start Information is located inside the information packet shipped with your unit.

Look on the front of your QuietCool in a plastic sleeve.

1.2 Evap-O-Matic – Chemical Water Treatment. Operate your unit 2 weeks – flush out old water – add clean water – then add Chemical Water Treatment tablet. Note; Tablet makes water foam which can cause unit to spit droplets of water temporarily. Foam subsides in 1 – 2 working days.

2.0 How Evaporative Cooling Works

Keeping in mind that regular fans only circulate same temperature air - same humidity – your QuietCool portable evaporative cooler takes that same existing air, combines it with evaporating water (*which dramatically lowers the temperature*) immediately relieving hot, dry areas, similar to the conditions when a natural rain storm approaches, the temperature drops noticeably cooler, because the air is saturated with water. Because your air is now saturated with water it becomes noticeably cooler. In high humidity areas the temperature will not be as cool – however, the QuietCool was engineered *efficient* to evaporate perspiration and sweat from employees to keep them cooler.

3.0 Unpacking your new QuietCool unit

Note: Carefully examine your QuietCool shipping carton for damage before opening. If your carton is damaged – notify the shipper immediately!

Your QC36” unit was shipped on a wooden skid covered with a cardboard cover and lid – strapped. First remove the straps then you may lift the whole cardboard box off the unit and skid. Your QuietCool must now be lifted off the wooden skid.

4.0 Set-up your QuietCool unit.

Roll your QuietCool unit to a level surface and lock the swivel casters to prevent accidental movement.

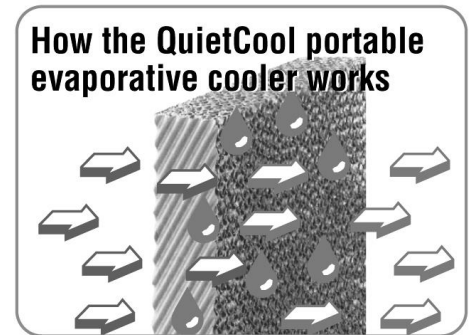

Hot, dryer air blowing through fan - about to mix with cooling media saturated with water.

Hot, dryer air - mixing with water molecules in the cooling media.

Moist, saturated air blowing out of fan - lowering the temperature up to 20° or more.

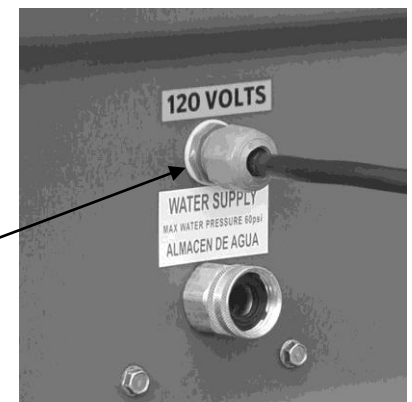

Electrical cord for 120V, 20Amp connection.
Note: Standard 3/4" water connection for utility water source under 60 p.s.i.

4.1 Connecting the electrical supply

All QuietCool models require regular 3 prongs, ground with 120 volt power supply. Plug electrical cord into receptacle. If using an extension cord be sure it is rated for at least 20 amps for the distance your cord is running. To be safe – make sure no other equipment is plugged into the same circuit. The QuietCool should run smoothly on 20 amp, 120 volt, and 60 Hz circuit.

4.2 Connecting the water supply

Connect standard water hose to female fitting on the right side of your QuietCool (looking at the fan blade side). If your water pressure is above 60 pounds per square inch (p.s.i.) you must use a pressure regulator (which can be found at your local hardware store). If you have purchased our optional QR60 gallon reservoir tank – simply attach the garden hose from the tank to the cooler. **Note:** Do not connect to water source exceeding 60 p.s.i. – this can cause damage to your QuietCool.

5.0 Operating procedures

Back your QuietCool unit up to a fresh air source such as an open door or window so the unit can pull in fresh air from the outside. Next, make sure you have a natural exhaust at the opposite end of the room, bay or building such as a window, door or bay door. This will ensure maximum efficiency from your unit. Finally make sure there are no obstructions between your QuietCool and the people / area you need to cool.

5.1 Filling the units reservoir with water

Once your water hose is connected – open the water flow valve (located on the front of your unit) only one and half (1 1/4) turns. *This water flow valve adjusts the amount of water to the unit.* Next, turn water on and fill the reservoir with water. Listen carefully. You can hear water filling the reservoir. Check your water connection – make sure there is no dripping. Once the reservoir is filled with water the float valve will automatically shut off the water source. When you no longer hear the water running – you know that the float valve is fully operational (the water turns off automatically) and you are now ready to turn on the water pump.

Warning! Do not run water pump without water in the reservoir.

5.2 Turn-on pump

To turn-on the water pump - flip the toggle switch for the water pump to on. Switch is located on front side of unit. **Warning! Do not run water pump without water in the reservoir.** The water pump will now begin pumping water to the top of the unit so that gravity will allow the water to run down the backside of unit inside and on the cooling pads. (If the water is dripping off of the pads on to the floor – turn your fan on low – close the flow valve a little to slow the water flow. After the pads are wet – you can

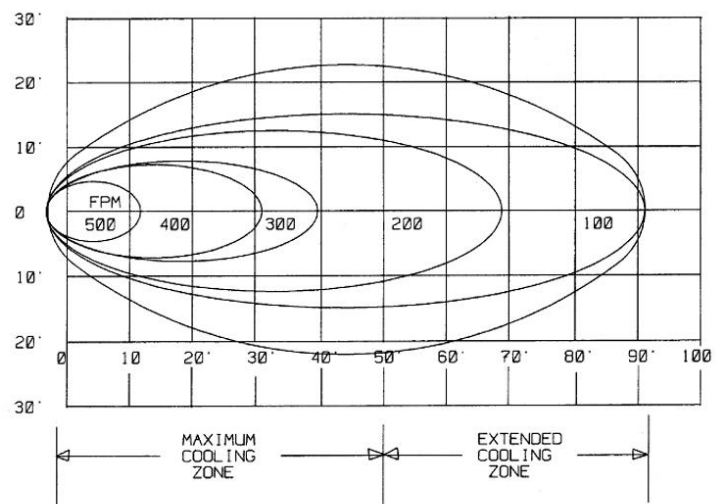

NOTE: EXTENDED COOLING ZONE: 40' TO 50' FROM QUIETCOOL UNIT. AIR MOVEMENT INCLUDES WARM AIR MIXING WITH COOLED AIR.

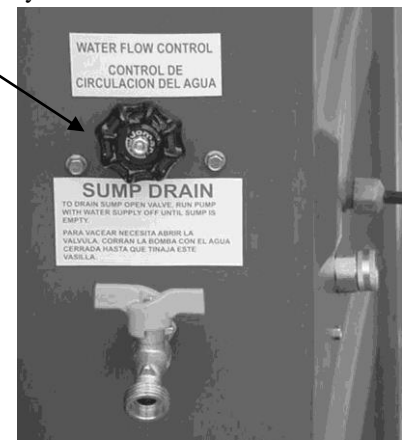

Top: Water control valve – controls water to units water reservoir. Open 1 ¼ turns.
Bottom: Water hook-up for cleaning and flushing water reservoir.

open the valve to 1 ¼ turn. Allow water to run for 10 – 15 minutes on new cooling pads to totally saturate them with water. Once your units cooling pads are saturated – then, you are ready to turn on fan and begin to feel the cooling effect from your new QuietCool. Note: After your cooling pads are broken in (typically takes 1 -2 weeks in operation) it will take less time to saturate pads for start-up.

5.4 Turn-on Fan

Once your cooling pads are wet – you may turn on your QuietCool unit. Now you can begin to feel the QuietCool difference in temperature. After your QuietCool has run for 5 minutes or so, visually inspect the pads – if water is dripping outside the unit – you have too much water, simply turn the water flow valve to the right ½ turn and inspect water flow in another 5 minutes. If there are dry streaks in the cel deck pads open the water flow valve handle ½ turn to increase water – check water flow in another 5 minutes and adjust accordingly. Most QuietCool operations work effectively with valve opened at 1 ¼ turns. This water valve is efficient – it requires minimal turning.

6.0 Daily Operating procedures

6.1 Turn-on water pump

Turn on water pump to unit – then, turn on fan to low – let cooling pads get saturated – then turn fan on high for cooling. Adjust the water flow – Your QuietCool operates most efficiently – and maintains uniform cooling pad wetness with the water control valve turned on at 1 ¼ turns. You must determine what works best for you and your specific environment.

6.2 Adjust water flow

Your QuietCool operates most efficiently – and maintains uniform cooling pad wetness with the water control valve turned on at 1 ¼ turns. You must determine what works best for you and your specific environment.

6.2 Turn on fan

When you can see that the cooling pads are saturated with water – turn fan on high and feel the cooler air coming from your QuietCool unit. Adjust the fan speed for your comfort.

6.4 Turn-off unit at end of day

15 minutes before closing for the day – turn off water pump with toggle switch – leave fan running – this action will shut-off water to the cooling pads while keeping the fan running. The fan will dry out the cooling pads. When the cooling pads are thoroughly dry – turn off fan. Drying your cooling pads thoroughly - everyday will help prevent mold and mildew growth, plus it will prolong the life of your cooling pads.

7.0 Maintenance

7.1 Access inside of unit

Turn-off water pump and let the fan continue to run until the cooling pads are thoroughly dry (about 10 – 15 minutes). Once your cooling pads are completely dry you may turn-off fan. Now unplug electricity to unit to avoid unnecessary shock. Next, using a 7/16” wrench – remove the two retaining bolts from the backside and topside (cooling pad side) of the unit. These

two bolts hold the metal angle retaining bar and the cooling pads in place. Next, remove the angle retaining bar and set to side. Now you are ready to remove your unit's cooling pads.

7.2 Removing the cooling pads

Before your start, make a note of the direction of the angle of the pads flutes (see side of pads). You must put pads back in correct order for your unit to function effectively. (Note: Install steep side 45° angle flute to the back of unit.)

Once the retaining angle bar is removed from the top of your QuietCool unit, reach to the top of the dry cooling pad to the left and gently take hold of the top of the pad and gently pull back and slightly down – this action will loosen the pad from the unit. Look at the direction of the angle of the pad flutes (*side of pads*). Remove the cooling pad and proceed to the next pad. Then, remove all five cooling pads and gently set in a safe place.

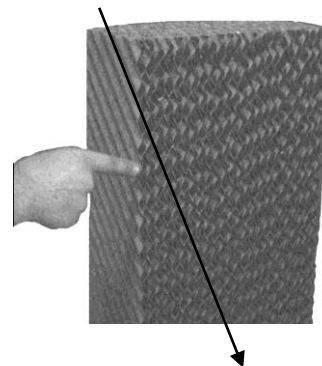

Note: this is a good time to take the cooling pads outside and run clean water over the pads to remove any accumulated dirt and debris. *Do not use high pressure hose* – this will damage pads and their ability to function effectively. Make sure the pads are thoroughly dry before placing back inside the unit. Full exposure to the sunlight is a good way to dry the pads while helping remove mold and mildew.

7.3 Daily maintenance

15 minutes before quitting time – turn off the water pump and let the fan run 10 – 15 minutes – to dry out the cooling pads before leaving. Inspect the cooling pads to make sure they are thoroughly dry (this action helps to reduce mold and mildew) when pads are completely dry then turn-off fan.

7.4 Periodic maintenance

Depending upon your environment and how often you operate your QuietCool will depend on how dirty your water gets in the reservoir and how often you will need to clean it. If you begin to detect an algae smell coming from your unit – it's time to flush your QuietCool reservoir with fresh water. Refer to and follow the steps above in 7.2 and you will only need to remove 1 or 2 of the cooling pads from the left side of the unit to gain access to your water reservoir. Take a small sponge and clean out your water reservoir with a light cleaner and wipe it down completely and let the unit dry. (You may want to use a wet / dry shop vacuum to clean out unit). When unit is clean add an Evap-O-Matic tablet – then replace your cooling pads (make sure flutes are facing correct direction) retaining bar and bolts and add fresh, clean water back to the units' water reservoir. Note: Adding Evap-O-Matic helps to reduce algae, mold and mildew. You can get the tablets by ordering from the QuietCool order form found in section 9.0. Simply follow instructions on the label. You may want to consider a Water Stabilizer to remove harmful calcium, scale build-up and algae – see section 9.0.

Note: You may want to remove most of water from water reservoir by attaching a garden hose to the drain valve and place the end of the garden hose into a drain then, running pump until sump is dry – shutting off pump immediately.

Warning! Do not run pump without water in the reservoir. This action will burn up your QuietCool's water pump.

Problem <i>(continued)</i>	Cause <i>(continued)</i>	Solution <i>(continued)</i>
5. Scale build-up on cooling pads.	Hard water with excessive mineral content.	<p>Use Evapo-O-Matic Tablets or add a Water Stabilizer at the discharge side of the pump. <i>See Accessories section 9.0.</i></p> <p>Flush water from unit's water reservoir more frequently. <i>See section 7.4.</i></p>

8.0 Storage

Remove pads as described above in 7.2 and rinse pads clean with fresh water. Dry cooling pads in sunlight. Drain water reservoir completely and wipe dry. Replace dry cooling pads. Replace top angle bar to hold pads in place. Store QuietCool in dry, clean area and cover (you can order a QCCover for your unit – see section 9.0) to prevent dust build up to have unit ready for the next hot season. Note: Make a list of accessories and needed parts – purchase off-season to save money.

9.0 Accessories

QuietCool accessories and parts were engineered to always fit your QuietCool unit – no matter how old. When you need a part – we have it in stock – if we don't have it – we'll make it.



QC36PM – Intake Pre-Filter for 36" unit. A *must* for environments with air-borne particles like sawdust or lint. (Shown with Guard) Suggest 2 intake filters. When one gets dirty – replace with second – clean first filter so it's ready when second gets dirty. Simply remove retaining bar at top to hold pre-filter in place.
List \$ 25.00 each.

QC36CC – Protective Cooler Cover for 36" unit. Plastic cover for unit to protect during storage. Helps keep unit clean during off-seasons.
List \$ 99.00 each.



Evapo-O-Matic Tablets for all QuietCool Portable Evaporative Coolers. Evapo-O-Matic is the chemical water treatment tablets that stops scale and calcium deposits associated with hard water. Adds life to vital cooler equipment – increases cooling efficiency and ends swampy odors. Treatment: 2 tablets for 36" units. *EPA registered protection from harmful air-borne organisms found in cooler equipment.*

QCTAB1 – Single tablet pack. **List \$ 16.00. NSN-4130-01-507-7080**
QCTAB2 – Double tablet pack. **List \$ 25.00 (12.50 ea.) NSN-4130-01-507-7081**
QCTAB12 – Jar of 12 tablets. **List \$ 99.00 (8.25 ea.) NSN-4130-01-507-7082**
Case of QCTAB12 – 12 Jars of 12 tablets each. (*Best buy at 6.93 each*). **List \$ 998.00**

QCG1001 – Water Stabilizer for 36" unit. The water stabilizer removes harmful calcium, scale build-up and algae by keeping it from collecting anywhere within your unit. The calcium and scale is flushed out of your unit when you flush out the sump – extending the life of your cooling pads and all internal water working parts. (*The water stabilizer must be connected inside the cooler at the discharge side of the water pump*).
List \$290.00.

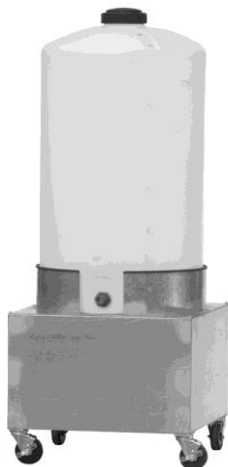

QRT60 – Quietaire Portable Water Reservoir for units where there is no access to water. Constructed with medium density polyethylene and a stand made of galvanized steel with 4" casters for easy moving. Has connection for standard water hose with valve. **List \$ 605.00 each. NSN-4130-01-449-4618**

QC10W –10" Semi-Pneumatic Rough Terrain Wheels designed for U.S. Military for use on rugged terrain. Also available for general public use too. *Complete set of 4 Wheels.* **List \$ 694.00 NSN-4130-01-507-7061**



10.0 Replacement Parts

All Accessories / Replacement Parts are obtainable through your local QuietCool distributor. Should a part be temporarily out of stock at your distributor he can special order it for you.

You can contact the manufacturer, Quietaire Cooling Inc. directly at: Telephone: 713.228.9421 or Fax: 713.228.9425.

Please have your units 1. Model number 2. Serial number (*look at front side of your cooler - on the right hand side – inside guard - on the fan shroud*) handy when you contact either your distributor or Quietaire Cooling Inc. for all Accessories / Replacement parts. This will assure that we are able to help you with the correct part the first time.



QCPUMP – Replacement Pump for all 36” units. Simply replace the new pump with the old pump.
List \$ 168.00 each.



TR798 – Float Valve for all 36” units. Automatically adjusts water level in units reservoir.
List \$ 16.00 each.



12Filter – Inline Filter for all 36” units. Simply open water filter located inside unit, remove old filter screen and replace with new filter.
List \$ 23.00.

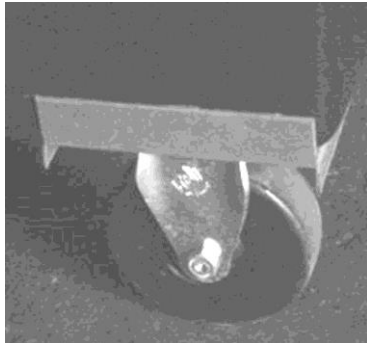

QC4X1RC – 4” Rigid Caster Replacement for all 36” units. Simply replace the new caster with the old caster. Sold in sets of 2.
List \$ 11.00 set.



QC4X1SC – 4” Swivel Caster Replacement for all 36” units. Simply replace the new caster with the old caster. Sold in sets of 2.
List \$ 11.00 set.

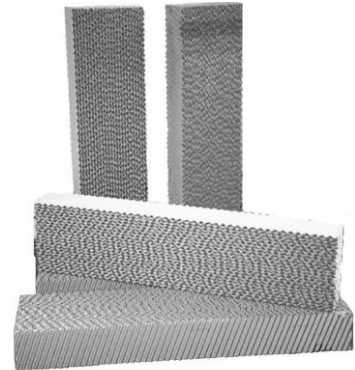

5-CD48612– Cooling Media Replacement for 36” unit. Cross corrugated angle fluted specially formulated cellulose material treated with a thermosetting resin. (*Replacement set of 5*).
List \$ 243.00 set. NSN-4130-01-507-7064

Direct from the manufacturer
QuietCool
Engineered. Efficient. Cooler.
“Amazing!”

Fax Back Order Form

Accessories and Replacement Parts For all QC48" fan blade models.

For all motors, pulleys, belts, switches and fan blades call Quietaire at 713.228.9421.

Accessories

Description	Part Number	Quantity	Amount	Price
Intake Pre-Filter – protects cooling pads from air-borne particles.	QC36PM		List \$ 25.00 each	
Protective Cooler Cover – protects cooler during long storage.	QC36CC		List \$ 99.00 each	
Evapo-O-Matic Tablets – Chemical water treatment tablets.	QCTAB1 – Single Tablet		List \$ 16.00 each <i>(16.00 per tablet)</i>	
Evapo-O-Matic Tablets – Chemical water treatment tablets.	QCTAB2 – 2 Tablets		List \$ 25.00 <i>(12.50 per tablet)</i>	
Evapo-O-Matic Tablets – Chemical water treatment tablets.	QCTAB12 – Jar of 12 Tablets		List \$ 99.00 <i>(8.25 per tablet)</i>	
Evapo-O-Matic Tablets – Chemical water treatment tablets.	Case of QCTAB12 12 Jars - 12 Tablets		List \$ 998.00 <i>(6.93 per tablet)</i>	
Water Stabilizer – Removes harmful calcium, scale build-up and algae.	QCG1001 – Water Stabilizer		List \$ 290.00 each	
Portable Water Reservoir – For use in field where there is no access to water.	QRT60 – Water Reservoir		List \$ 605.00 each	
Rough Terrain Wheels – 10" Semi-Pneumatic wheels. Sold as set	2-QC10x3RC 2-QC10x3SC		List \$ 694.00 set	

Replacement Parts

Description	Part Number	Quantity	Amount	Price
Water Pump Replacement – Pumps water up to cooling pads.	QCPUMP		List \$ 168.00 each	
Float Valve Replacement – Automatically adjusts water level.	TR798		List \$ 16.00 each	
Inline filter – Catches large debris in water line to cooling pads.	12Filter		List \$ 23.00 each	
Replacement Caster (Straight Wheel) – Sold in set of 2.	QC4X1RC - 2 Wheels		List \$ 22.00 set	
Replacement Caster (Swivel Wheel) – Sold in set of 2.	QC4X1SC - 2 Wheels		List \$ 24.00 set	
Cooling Pad Replacement – Replacement set of 5 pads.	5-CD48612 – Set of 5 cooling pads		List \$ 243.00 set	



Credit Card Type: _____ Credit Card Number: _____
 Expiration Date: _____ Name On Card: _____

Sub Total	\$
Texas Sales Tax	\$
Total	\$

Add up totals for needed accessories and replacement parts and Fax to: 713.228.9425

Texas residents add .0825 State Sales Tax. **Shipping Charges:** Fax your Zip Code and Shipping Address.

Name: _____

Company Name: _____

Telephone Number: _____ Fax Number: _____

Billing Address: _____

Shipping Address: _____

City: _____ State: _____ Zip: _____

12.0 Wiring Diagrams for all 36" units

QC36D1 - 1/2 HP 1 SPEED WIRING DIAGRAM

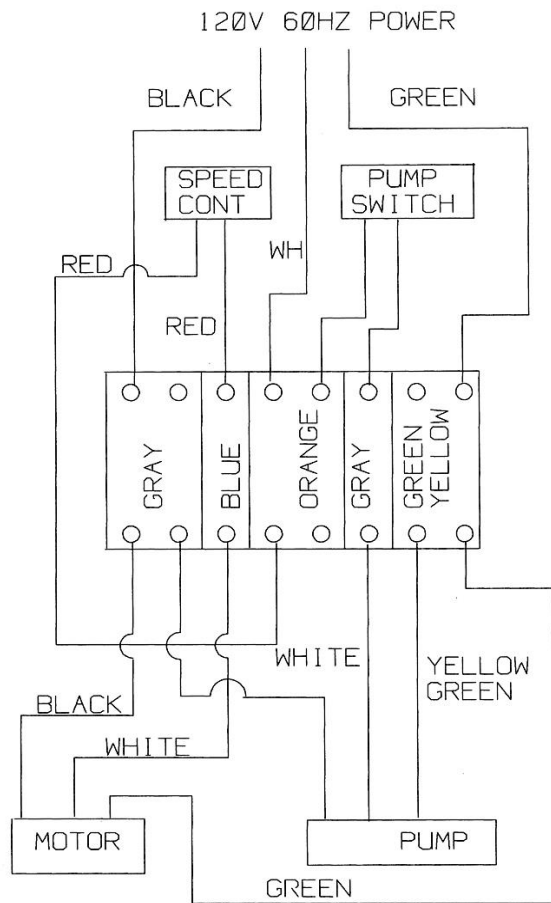
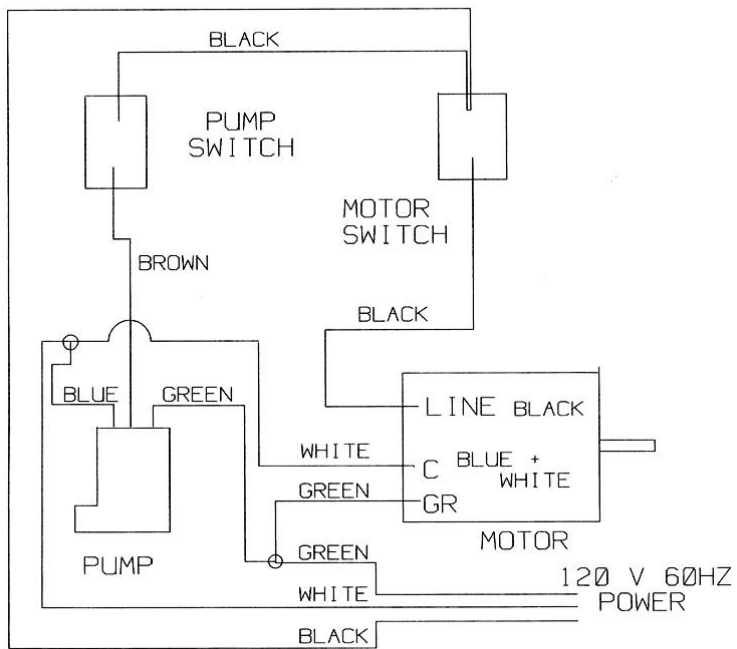

QC36DVS
36" VARIABLE SPEED WIRING DIAGRAM

QC36B1 -1/2 HP 1 SPEED WIRING DIAGRAM
 QC36B1X -3/4 HP 1 SPEED WIRING DIAGRAM

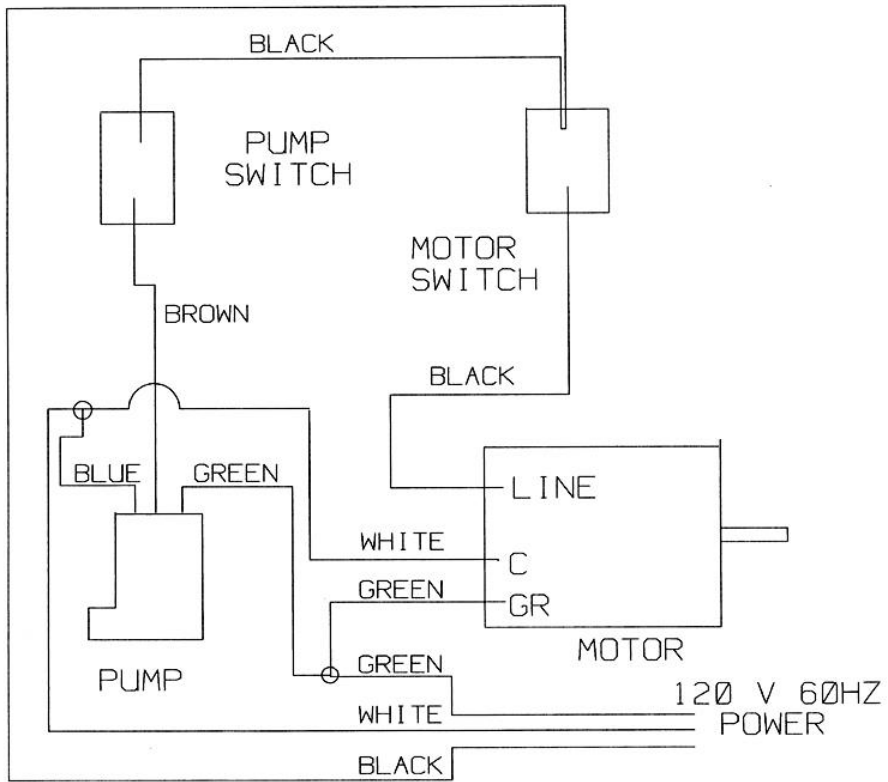

QC36B1 -1/2 HP 1 SPEED WIRING DIAGRAM
 QC36B1X -3/4 HP 1 SPEED WIRING DIAGRAM

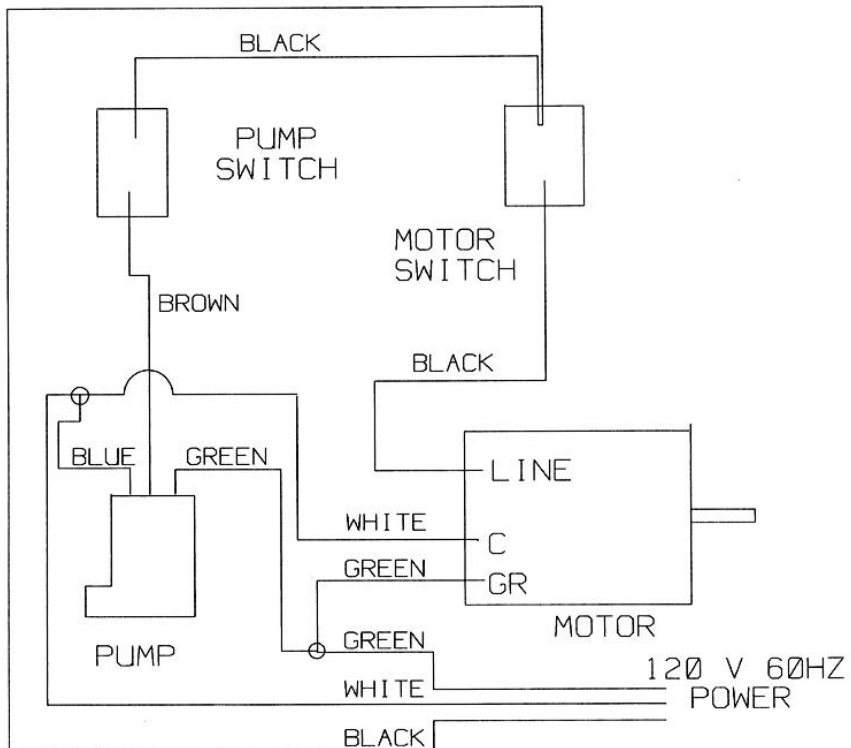

QC36B1XHL - 3/4 HP ONE SPEED EXPLOSION
PROOF WIRING DIAGRAM

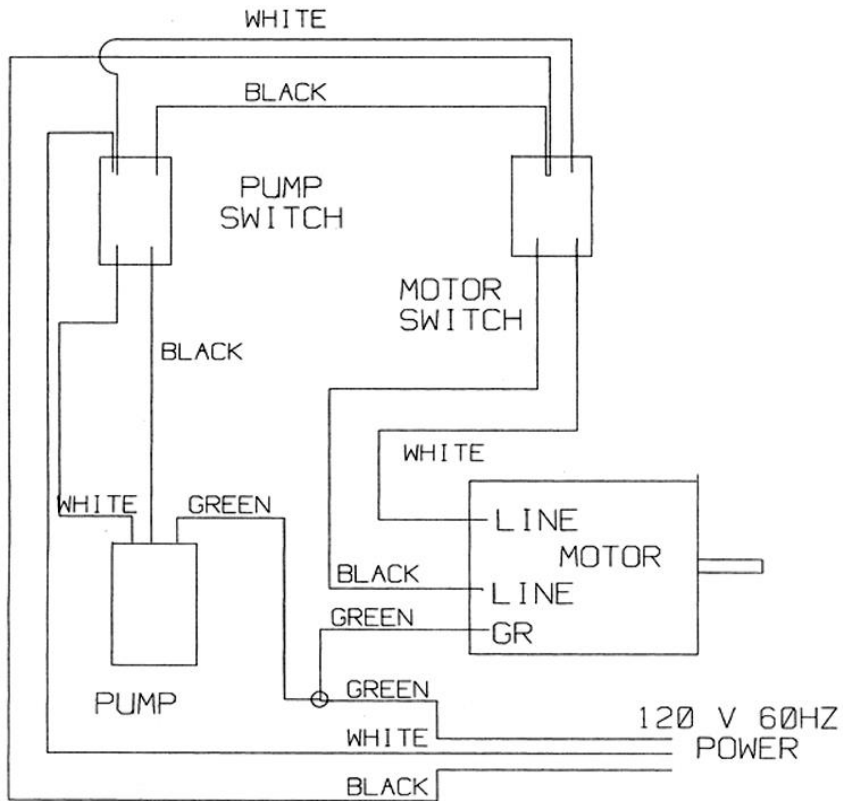

QC36B3
1/2 HP THREE SPEED WIRING DIAGRAM

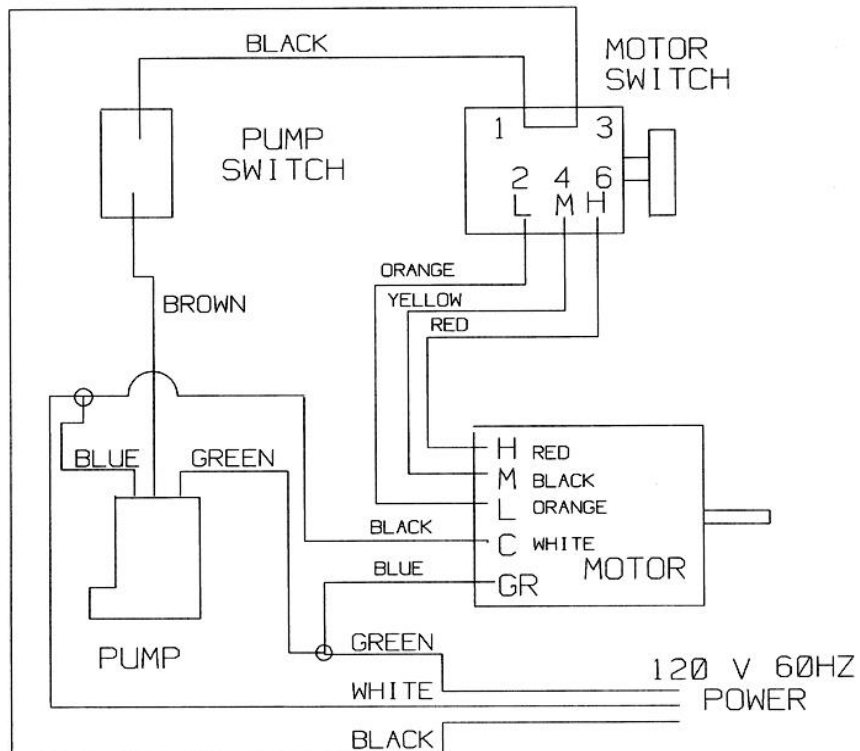

13.0 Warranty

WARRANTY

WARRANTY AND DISCLAIMER: Quietaire Cooling extends this limited warranty to the original buyer and warrants that products manufactured by Quietaire Cooling shall be free from original defects in workmanship and material for one year from date of shipment, provided same have been properly stored, installed, service, maintained and operated. This warranty shall not apply to products which have been altered or repaired in any way so as to effect its performance, without Quietaire Cooling's express authorization, or altered or reliability, nor which have been improperly installed or subjected to misuse, negligence, or accident, or incorrectly used in combination with other substances. The Buyer assumes all risks and liability for results of; use for the products. Warranties on purchased parts, such as electric motor and controls are limited to the terms of warranty extended by our supplier.

LIMITATION OF REMEDY AND DAMAGES: All claims under this warranty must be made in writing and delivered to Quietaire Cooling 505 N. Hutcheson, Houston, Texas, 77003 within 15 days after discovery of the defect and prior to the expiration of one year from the date of shipment by Quietaire Cooling of the product claimed defective, and Buyer shall be barred from any remedy if Buyer fails to make such claims within such period.

Within 30 days after receipt of a timely claim, Quietaire Cooling shall have the option either to inspect the product while in Buyer's possession or to request Buyer to return the product to Quietaire Cooling at Buyer's expense for inspection by Quietaire Cooling. Quietaire Cooling shall replace, or at its option repair, free of charge, any product it determines to be defective, and it shall ship the repaired or replacement product to Buyer F.O.B. point of shipment; provided, however, if circumstances are such as Quietaire Cooling judgment to prohibit repair or replacement to remedy the warranted defects, the buyer's sole and exclusive remedy shall be a refund to the buyer of any part of the invoice price, paid to Quietaire Cooling for the defective product or part.

Quietaire Cooling is not responsible for the cost of removal of the defective product or part, damages due to removal, or any expenses incurred in shipping the product of part to or from Quietaire Cooling plant, or the installation of the repaired or replaced product or part.

Implied warranties, when applicable, shall commence upon the same date as the express warranty provided above, and shall except for warranties of title, extend only for the duration of the express warranty provided above. Some states do not allow limitations on how long an implied warranty lasts, so the above limitation may not apply to you. The only remedy provided to you under an applicable implied warranty and the express warranty shall be the remedy provided under the express warranty, subject to terms and conditions contained therein. Quietaire Cooling shall not be liable for incidental and consequential losses and damages under the express warranty, any applicable implied warranty, or claims for negligence, except to the extent that his limitation is found to be unenforceable under applicable state law. Some states do not allow exclusion or limitation of incidental or consequential damages, so the above limitation or exclusion may not apply to you. The warranty gives you specific legal rights, and you may also have other rights which vary from state to state.

No employee, agent, dealer, or other person is authorized to give any warranties on behalf of Quietaire Cooling or to assume for Quietaire Cooling any other liability in connection with any of its products except in writing and signed by an officer of Quietaire Cooling.

TECHNICAL ADVICE AND RECOMMENDATION, DISCLAIMER: Notwithstanding any past practice or dealings or any custom of the trade, sales shall not include the furnishing of technical advice or assistance or system design, any such assistance shall be at Quietaire Cooling sole option and may be subject to additional charge.

Quietaire Cooling assumes no obligation or liability on account of any recommendations, opinions, or advice as to the choice, installation or use of products, Any such recommendations, opinions or advice are given and shall be accepted at your own risk and shall not constitute any warranty or guarantee of such products or their performance.

QUIETAIRE COOLING INC.
505 NORTH HUTCHESON STREET
HOUSTON, TEXAS 77003
TELEPHONE: 713.228.9421 FAX: 713.228.9425

Visit us online at: www.Quietaire.com *Click on QuietCool*