

ASSEMBLY INSTRUCTIONS / OWNERS MANUAL

IMPORTANT: READ ALL ASSEMBLY INSTRUCTIONS AND SAFETY PRECAUTIONS BEFORE USING THIS PRODUCT. REFERENCE ALL SAFETY GUIDELINES AND WARNING LABELS. RETAIN PRODUCT LITERATURE FOR FUTURE REFERENCE.

SAFETY: PROPERLY WARM UP AND STRETCH BEFORE EXERCISING. IF YOU FEEL PAIN OR DIZZINESS AT ANY TIME WHILE EXERCISING, STOP IMMEDIATELY AND CONSULT YOUR PHYSICIAN.

ASSEMBLY PREPARATION

To ensure ease of product assembly, please take time to verify the size and quantities of all required assembly hardware. Use the itemized parts listing and hardware chart for reference.

The product assembly process has been documented in easy to follow stages. Please read all assembly instructions carefully. Take time to review the manual and familiarize yourself with the entire assembly process before proceeding.

Assembly Tip: It is always helpful to pre-stage the items needed for each assembly step.

Perform product assembly in a 4ft. x 6ft. flat area. **Note:** After assembly is completed, allow a minimal of 2-3ft. of space on each side of bike for user access and dismounting.

Do not dispose of any packaging materials until assembly of the product is completed.

Assembly tools are included, but you may also use standard household tools to complete assembly of this product.

If you experience problems with operation of the equipment after assembly, please reference the troubleshooting guide in this manual.

For added component life, follow the preventative maintenance tips listed in this manual.

Make sure to completely fill-out the product registration form & return it to us within 30-days of purchase.

Please contact us if you have additional questions or need service assistance at 1-888-678-2476.

IMPORTANT PRECAUTIONS

WARNING: To reduce the risk of injury, please read the following precautions before assembling or using your new product.

1. It is the responsibility of the owner to ensure that all users of this equipment are adequately informed of stated precautions.
2. Read all instructions and enclosed literature carefully. Understand the assembly and operation before using the equipment.
3. Use equipment on a flat level surface. Use adjustment levelers on the bottom of equipment to help stabilize unit.
4. It's recommended to place an exercise mat beneath the equipment for added protection of floors or carpets.
5. Keep children & pets away from equipment at all times. Lock the fan wheel in place for added safety while not in use.
6. Inspect product on a frequent basis. Tighten loose assemblies or hardware as needed. Replace worn or damaged parts.
7. This equipment is intended for internal home use only. Do not use in a non-residential environment. Use in non-recommended environments can lead to serious injury and will void all related warranties & liabilities.
8. Recommended user weight should not exceed **300 lbs.**
9. Keep equipment clean and properly maintained.
10. Observe and adhere to all warning labels posted on equipment.
11. Properly warm-up and stretch before starting any strength training or cardio exercise routine.
12. If you feel pain or dizziness at any time while exercising, stop immediately and consult your physician.

Safety Warning: Before starting an exercise program, consult your physician. This is especially important for individuals over the age of 35 or persons with pre-existing health problems. It's important to read all instructions carefully. We assume no responsibility for personal injury or consequential damages sustained by or through the use of this equipment. Additional terms & conditions are listed in the back of this manual or enclosed owners manual.

Colors and specifications are subject to change without notice.

ASSEMBLY PARTS LIST

Item #	Part Number	Description	QTY.
1	060-0038	Base Frame Assembly	1
2	060-0001	Front Stabilizer Assembly	1
3	060-0002	Rear Stabilizer Assembly	1
4	060-0003	Sensor Cable	1
5	060-0004	Console	1
6	060-0005	Console Mast	1
7	060-0006	Adjustable Seat Slider	1
8	060-0007	Seat Post	1
9	060-0008	Seat	1
10	060-0009	Seat Slider Adjustment Knob	1
11	060-0010	Seat Back Post	1
12	060-0011	Seat Post Adjustment Knob	1
13	060-0012	Seat Back Bracket	1
14	060-0013	Seat Back Pad	1
15	060-0014	Connecting Arm (Preinstalled)	2
16	060-0015	Left Pivot Arm Assembly	1
17	060-0016	Right Pivot Arm Assembly	1
18	060-0017	Left Foot Rest	1
19	060-0018	Right Foot Rest	1
20	060-0019	Left Pedal	1
21	060-0020	Right Pedal	1
22	060-0021	(Large) Carriage Bolt M8 x 50 Length	4
23	060-0022	(Large) Spring Washer 20 x 8.5 x 1.5t	12
24	060-0023	(Large) Acorn Nuts M8	12
25	060-0024	(Small) Carriage Bolts M6 x 35 Length	2
26	060-0025	Pan Head Screw	4
27	060-0026	Button Head Allen Bolt M8 x 40 Length	2
28	060-0027	Button Head Allen Bolt M8 x 12 Length	2
29	060-0028	Button Head Allen Bolt M8 x 15 Length	6
30	060-0029	Pivot Bolt M8 x 35 Length	2
31	060-0030	Flat Washer 20 x 8.5 x 1.5t	2
32	060-0031	Nylon Nut M8	2
33	060-0032	(Small) Spring Washer 10 x 6.5 x 1.5t	2
34	060-0033	(Small) Acorn Nut M6	2
35	060-0034	Cage, Water Bottle	1
36	060-0035	Water Bottle	1

StairMaster® Zephyr Assembly Parts

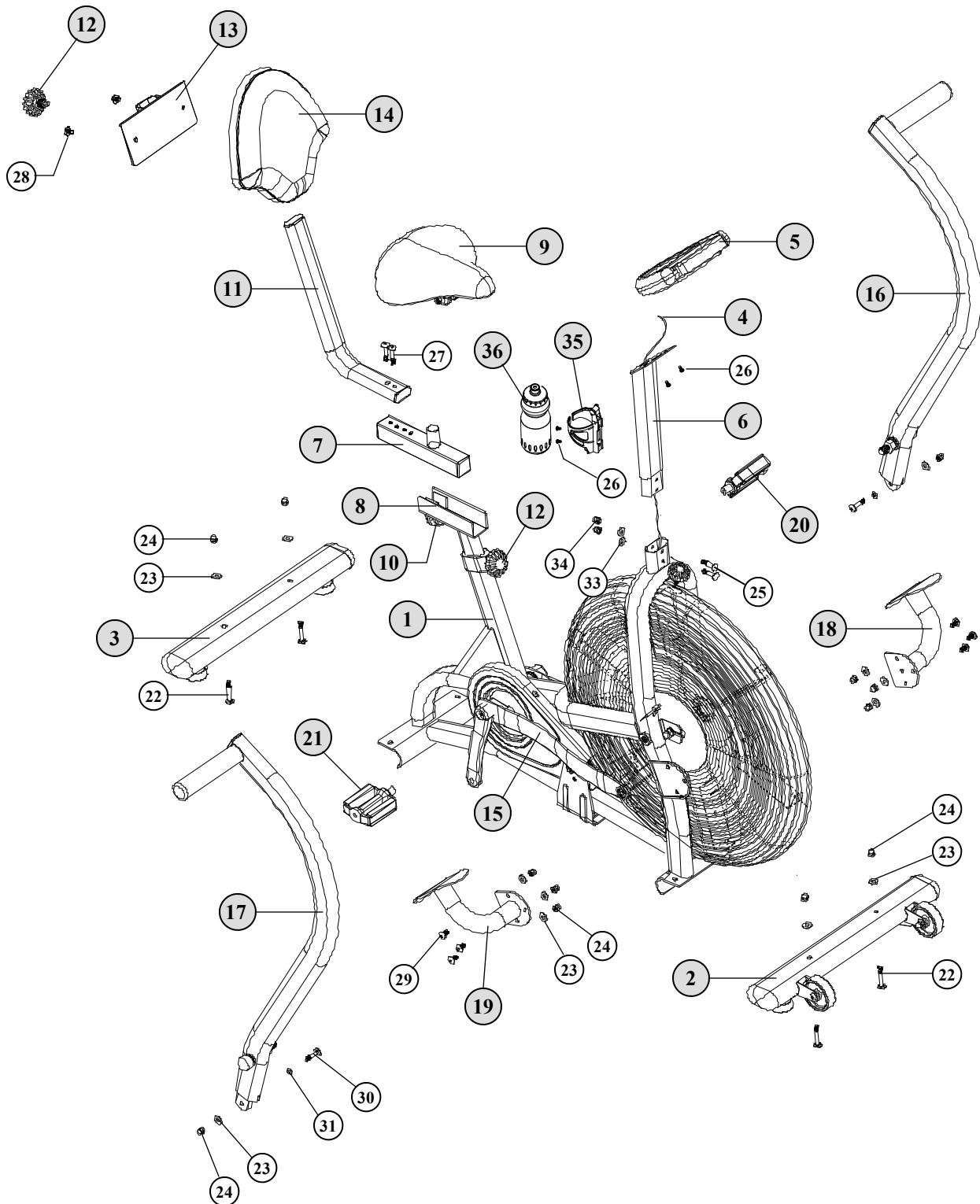

NOTE: THE EXPLODED PARTS VIEW IS SHOWN FOR REFERENCE ONLY. SOME ITEMS MAY BE PREASSEMBLED. PLEASE REFER TO THE INDIVIDUAL ASSEMBLY STAGE INSTRUCTIONS FOR DETAILED PARTS ORIENTATION.

ASSEMBLY STAGE #1

Attach Stabilizers to the Main Base

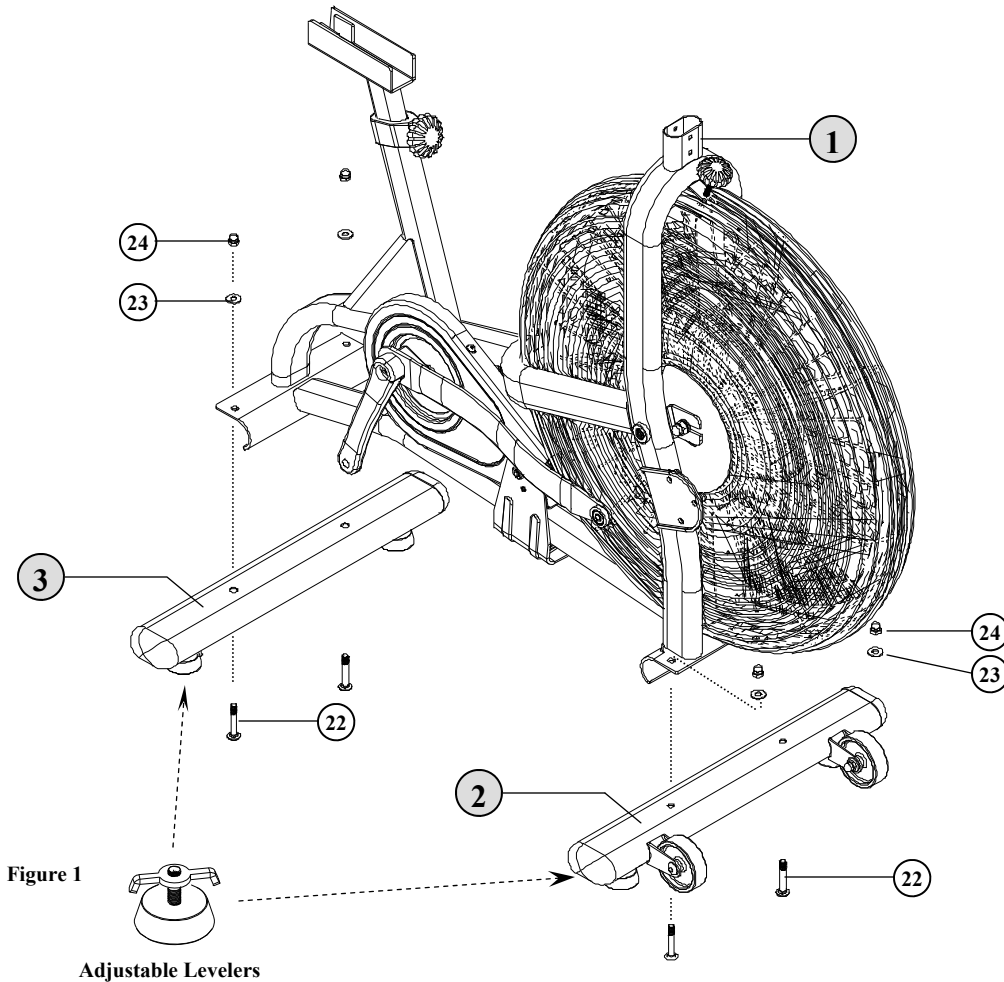

Assembly Hardware Required:

#22	Carriage Bolt	Qty. 4	#24	Acorn Nut	Qty. 4
#23	Spring Washer	Qty. 4			

Assembly Description:

- A) Assemble the **Front Stabilizer Assembly (#2)** to the **Main Base Assembly (#1)** using 2-**Carriage Bolts (#22)**, 2-**Flat Washers (#23)**, and 2-**Acorn Nuts (#24)**. **Note:** Make sure that the transport wheels on the Front Stabilizer are facing away from the Main Base Assembly as shown.
- B) Assemble the **Rear Stabilizer Assembly (#3)** to the **Main Base Assembly (#1)** using 2-**Carriage Bolts (#22)**, 2-**Flat Washers (#23)**, and 2-**Acorn Nuts (#24)**.
- C) Use the **Adjustable Levelers** on the bottom of the **Stabilizer Assemblies** to adjust the bike and keep it from rocking on an uneven surface (Figure 1).

Assembly Step #1 completed.

ASSEMBLY STAGE #2

Attach Console Mast & Mount Computer on the Main Base

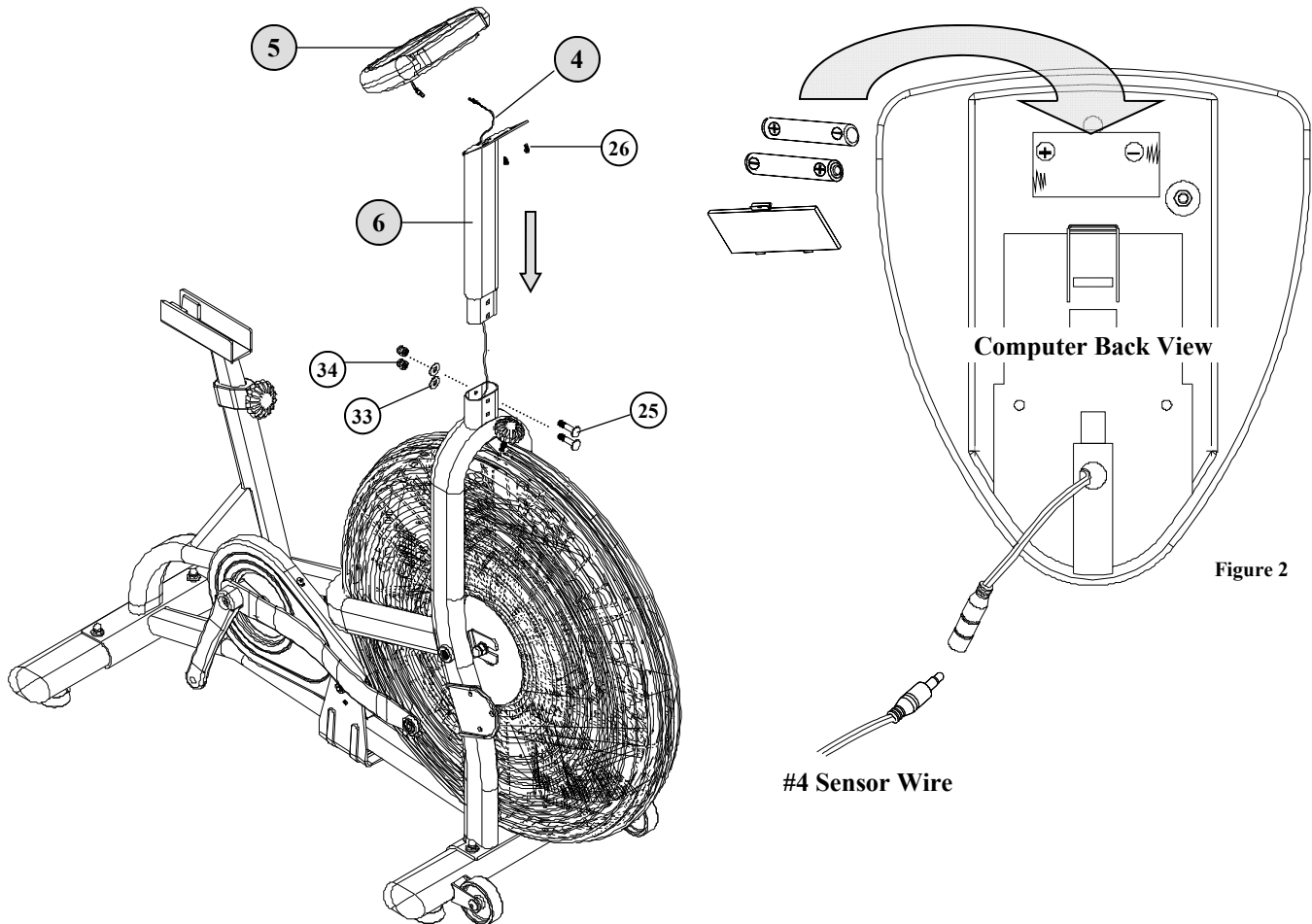

Assembly Hardware Required:

#25	Carriage Bolt	Qty. 2	#33	Spring Washer	Qty. 2
#26	Pan Head Screw	Qty. 2	#34	Acorn Nut M6	Qty. 2

Assembly Description:

- A) Carefully route the **Sensor Cable (#4)** through the **Computer Mast (#6)** and slide the mast down onto the corresponding mounting area of the **Base Frame Assembly**. Secure the mast to the base frame using **2-Carriage Bolts (#25)**, **2-Spring Washers (#33)**, and **2-Acorn Nuts (#34)**.
- B) Install **(2) AA Batteries** into the back of the **Computer (#5)**, as shown in **Figure 2**. Connect the **Sensor Cable (#4)** to the receptacle end of the cable coming from the back of the computer. Tuck the excess cable length into the mast and slide the computer onto the mast mounting plate. Secure the computer in place using **2-Pan Head Screws (#26)**.

Assembly Stage #2 completed.

ASSEMBLY STAGE #3

Attach Seat Slider and Seat to Main Base Assembly

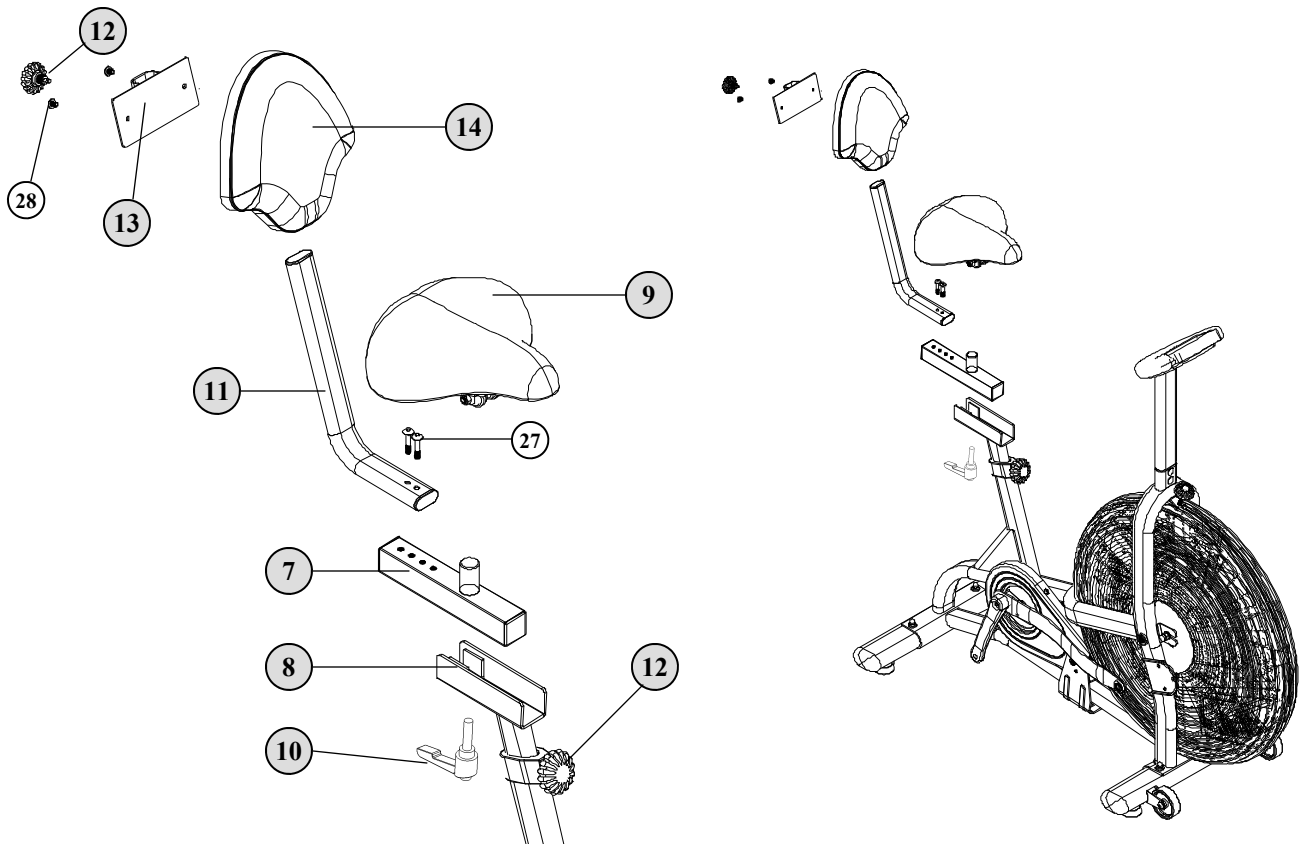

Assembly Hardware Required:

#27	Button Head Allen Bolt	Qty. 2	#28	Button Head Allen Bolt	Qty. 2
-----	------------------------	--------	-----	------------------------	--------

Assembly Description:

- A) Insert the **Adjustable Seat Slider** (#7) into the u-channel of the **Seat Support Post** (#8). Secure the seat slider assembly in place using the 1-**Seat Adjustment Knob** (#10).
- B) Attach the **Seat Back Post** (#11) to the **Adjustable Seat Slider** (#7) using 2-**Button Head Allen Bolts** (#27).
- C) Assemble **Seat** (#9) onto the knurled post of the seat slider. Set the seat at the desired position and secure it in place by tightening the u-clamp on the underside. Tighten the clamp until the seat no longer twists or tilts.
- D) Assemble the **Seat Back Bracket** (#13) to the **Back Pad** (#14) using 2-**Button Head Allen Bolts** (#28). Slide the back pad assembly over the **Seat Back Post** (#11) and lock into a desired position using **Back Pad Adjustment Knob** (#12)

Seat Adjustments: Adjust the seat height by unscrewing and pulling out on the **Seat Post Adjustment Knob** (#12). Select a desired seat post height and retighten the knob until seat post is secure. **Proper Height Adjustment:** Adjust seat height so the user is comfortable during use (pedaling motion). As a reference point, the users leg should be slightly bent at the bottom of the pedal stroke. The horizontal seat position can be adjusted using the **Seat Slider** (#7). Note: If the seat post wobbles during use, make sure the u-clamp and all adjustment knobs are securely tightened.

Assembly Stage #3 completed.

ASSEMBLY STAGE #4

Attach Pivot Arms to the Main Base

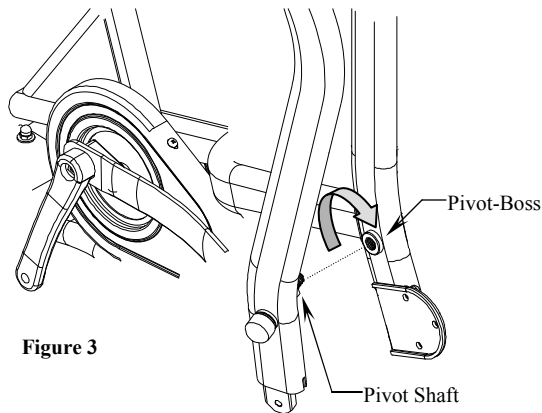

Figure 3

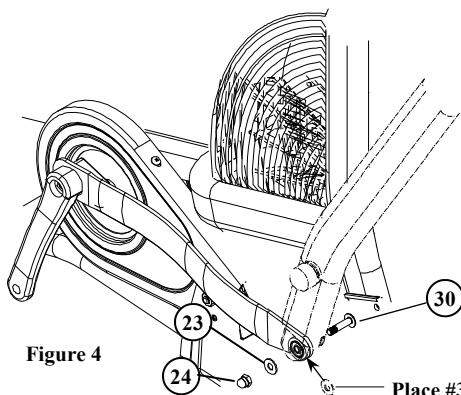
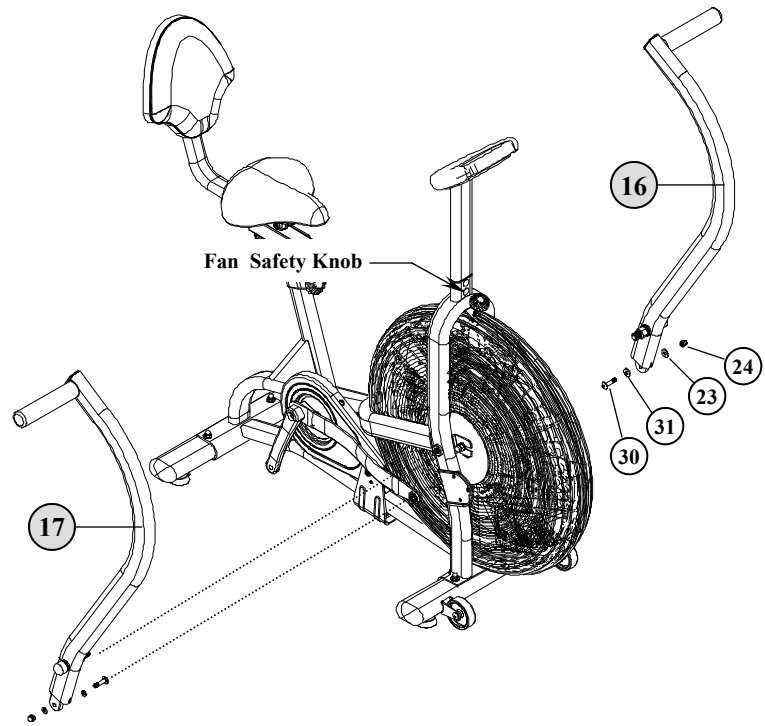

Figure 4



Assembly Hardware Required:

#23	Spring Washer	Qty. 2	#30	Pivot Bolt M8	Qty. 2
#24	Acorn Nut M8	Qty. 2	#31	Flat Washer	Qty. 2

Assembly Description:

- A) Install the **Pivot Arms** (#16 & #17) by threading the (preinstalled) pivot shaft into the corresponding pivot-boss of the **Base Frame Assembly** (#1). Using a standard crescent wrench (not included), thread each shaft into the pivot-boss using a clockwise rotation. Fully tighten each shaft until it is flush against the pivot-boss of the Base Frame Assembly. (Reference Figure #3)
- B) Once the Pivot Arms are mounted to the Base Frame Assembly, attach the ends of the **Connecting Arms** (#15) using 1-**Pivot Bolt** (#30), 1-**Flat Washer** (#31), 1-**Spring Washer** (#23), and 1-**Acorn Nut** (#24) per side. (Figure #4).

Hardware Orientation: The #31-Flat Washer must be placed in-between the connecting arm and inner flange mounting of the Pivot Arm. (Reference Figure #4).

Safety Note: The arm / pedal movement can be locked in place by turning the Fan Safety Knob until it makes contact with the fan wheel.

Assembly Stage #4 completed.

ASSEMBLY STAGE #5

Attach Pedals & Foot Rest to the Main Base Assembly

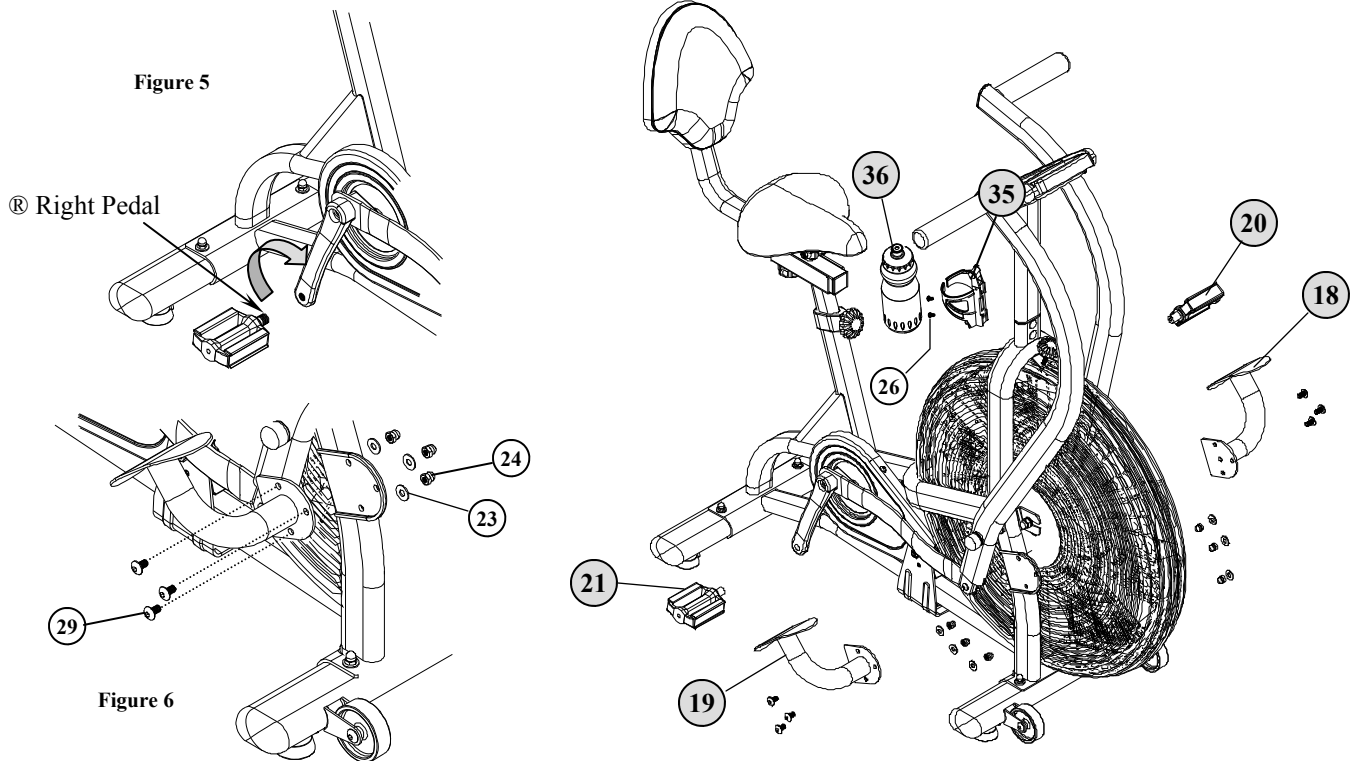

Assembly Hardware Required:

(*Assembly hardware may be preinstalled)

#23	Spring Washer	Qty. 6	#26	Pan Head Screw*	Qty. 2
#24	Acorn Nut	Qty. 6	#29	Button Head Allen Bolt	Qty. 6

Assembly Description:

Assembly Note: The right and left pedals are appropriately marked (R) and (L). The threading orientation on the left pedal is reversed from the threading orientation on the right pedal. To avoid stripping of the threads on the pedals or crank arms, make sure to follow the proper assembly orientation.

- A) Assemble the **Right Pedal** (#20) to the **Right Crank Arm** on the **Main Base Assembly**. Thread the pedal on the crank arm (**clockwise**) and securely tighten with the pedal wrench (included). (Reference Figure #5)
- B) Assemble the **Left Pedal** (#21) to the **Left Crank Arm** on the **Main Base Assembly**. Thread the pedal onto the crank arm (**counterclockwise**) and securely tighten with the pedal wrench (included).
- C) Mount the **Left & Right Foot Rest** (#18 & #19) to the **Main Base Assembly** (#1) using 3-**Button Head Allen Bolts** (#29), 3-**Spring Washers** (#23), and 3-**Acorn Nuts** (#24) per side. (Reference Figure #6)
- D) Mount the **Bottle Cage** (#35) to the **Computer Mast** (#6) using 2-**Pan Head Screws** (#26). Insert **Sport Bottle** (#36) into the cage. (Note: Washing the bottle before use is recommended)

Assembly Tip: Take time to review the additional information regarding computer operation, product maintenance, and warranty.

Congratulations !

You have successfully completed the assembly of this product and you are ready to start exercising toward a healthier lifestyle!

BUTTON FUNCTIONS

MODE	THE “MODE” BUTTON WILL SELECT AND SCROLL THROUGH EACH DISPLAY FUNCTION.
RESET	THE RESET BUTTON CAN BE USED TO ZERO OUT AN INDIVIDUAL DISPLAY FUNCTION.
TOTAL RESET	THIS BUTTON WILL ZERO OUT ALL DISPLAY READINGS AND PRESET VALUES. NOTE: THE REMOVAL OF THE BATTERIES WILL ALSO RESET ALL DISPLAY FUNCTIONS TO ZERO.
UP	THIS BUTTON ADJUST (INCREASES) FUNCTION VALUES.
DOWN	THIS BUTTON ADJUST (DECREASES) FUNCTION VALUES .

DISPLAY FUNCTIONS

SPEED	THE COMPUTER WILL REFERENCE A TRAINING SPEED BASED ON CORRESPONDING PEDAL RPM.
TIME	COMPUTER DISPLAY WILL ACCUMULATE TOTAL TRAINING TIME IN 00:00 (MINUTES : SECONDS). COMPUTER WILL COUNT UP TO A MAXIMUM DISPLAY READING OF 99:99. PRESET TARGET TRAINING TIME: USE THE “MODE” BUTTON TO SCROLL TO TIME FUNCTION AND PRESS THE “UP OR DOWN” BUTTONS TO SET THE DESIRED TIME. SETTINGS WILL BE ENTERED IN 1:00 MINUTE INCREMENTS AND THE COMPUTER WILL COUNT DOWN FROM THE SET TIME. ONCE THE DESIRED TIME IS SET, START PEDALING TO BEGIN TRAINING OR PRESS THE “MODE” BUTTON TO CONTINUE THE TARGET SET UP OF OTHER FUNCTIONS.
DISTANCE	THE COMPUTER ACCUMULATES TRAINING DISTANCE FROM 0.00 TO A MAXIMUM OF 99.99 MILES. EACH INCREMENT WILL BE DISPLAYED IN 0.01 MILE. PRESET A TARGET TRAINING DISTANCE: USE THE “MODE” BUTTON TO SCROLL TO THE TIME FUNCTION AND PRESS THE “UP OR DOWN” BUTTON TO SET A DESIRED DISTANCE. EACH SETTING WILL BE IN INCREMENTS OF 0.5 MILE AND THE COMPUTER WILL COUNT DOWN FROM THE SET DISTANCE. ONCE THE DESIRED DISTANCE IS SET, START PEDALING OR PRESS THE “MODE” BUTTON TO CONTINUE THE TARGET SET UP OF OTHER FUNCTIONS.
SCAN	THE COMPUTER WILL AUTOMATICALLY SCAN (CYCLE) THROUGH EACH FUNCTION READING EVERY 5 SECONDS. THE LARGE CHARACTER INFORMATION WILL CORRESPOND TO A BLINKING FUNCTION WINDOW AT THE BOTTOM OF THE DISPLAY. SCAN (CYCLING) SEQUENCE; SPEED, TIME, DISTANCE, AND CALORIES. NOTE: THE SCAN FUNCTION CAN BE TURNED OFF DURING A TRAINING SESSION BY PRESSING THE “MODE” BUTTON ONCE. THE SCAN SEQUENCE CAN BE REACTIVATED BY USING THE “MODE” BUTTON TO MANUALLY SCROLL TO THE BEGINNING FUNCTION WINDOW (SPEED READING). AT THIS POINT, THE WORD “SCAN” WILL APPEAR IN THE UPPER LEFT CORNER AND AUTOMATICALLY BE REACTIVATED.

DISPLAY FUNCTIONS (Continued)

CALORIE

COMPUTER ACCUMULATES TOTAL CALORIE CONSUMPTION (BURN) DURING A TRAINING PERIOD. COMPUTER WILL COUNT IN 1 CALORIE INCREMENTS, FROM 0 TO A MAXIMUM READING OF 9999 CALORIES.

PRESET A TARGET CALORIE BURN: USE THE "MODE" BUTTON TO SCROLL TO THE CALORIE FUNCTION AND PRESS THE "UP OR DOWN" BUTTONS. SETTINGS CAN BE ENTERED IN INCREMENTS OF 10 CALORIES AND THE COMPUTER WILL COUNT DOWN FROM THE SET CALORIE VALUE. ONCE THE CALORIE FUNCTION IS SET, START PEDALING TO BEGIN TRAINING OR PRESS THE "MODE" BUTTON TO CONTINUE THE TARGET SET UP OF OTHER FUNCTIONS.

NOTE: THE REPORTED CALORIE DATA IS ONLY A REFERENCE GUIDE FOR THE USER. IT SHOULD NOT BE USED IN COMPARISON OF CALIBRATED MEDICAL EQUIPMENT.

TRAINING NOTE:

EACH FUNCTION WILL ALWAYS RESET TO A ZERO VALUE AFTER A PRESET TARGET IS ACHIEVED. THE COMPUTER WILL AUTOMATICALLY START COUNTING UP FROM ZERO IF A USER CONTINUES TO TRAIN (PEDAL) AFTER REACHING A TARGET VALUE.

FEATURES

AUTO START

COMPUTER WILL ACTIVATE ONCE A SENSOR SIGNAL IS DETECTED (PEDAL OR ARM MOVEMENT).

SLEEP MODE

COMPUTER WILL AUTOMATICALLY STOP DISPLAYING FUNCTION READINGS AFTER 5 MINUTES OF NOT RECEIVING A SENSOR SIGNAL.

NOTE: START PEDALING TO REACTIVATE THE COMPUTER.

TIME & TEMP

THE COMPUTER WILL ALWAYS DISPLAY THE ROOM TEMPERATURE AND TIME WHEN THE OTHER FUNCTIONS ARE NOT IN USE OR COMPUTER IS IN A SLEEP MODE.

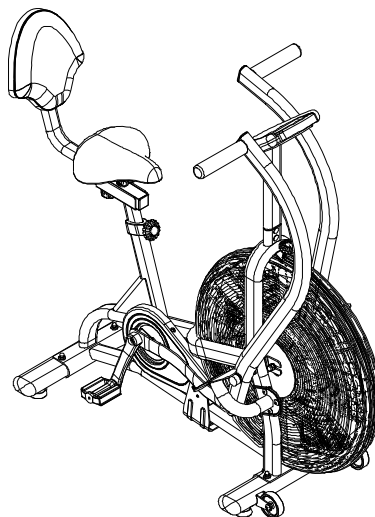

BASIC TROUBLESHOOTING TIPS

PROBLEM DESCRIPTION	SUGGESTED SOLUTION
NO DISPLAY	<ol style="list-style-type: none"> 1) CHECK BATTERY ORIENTATION: + / - 2) CHECK BATTERY VOLTAGE: (2) AA BATTERIES 1.5 VOLTS EACH 3) CHECK CABLE CONNECTIONS: MAKE SURE CONNECTIONS ARE SECURE AND IN THE CORRECT ORIENTATION. 4) CHECK CABLE ASSEMBLIES FOR DAMAGE: PINCH POINTS & POSSIBLE SHORTING OF WIRES. 5) CHECK FOR POSSIBLE COMPUTER DAMAGE: CRACKED DISPLAY WINDOW (BLACK SCREEN). <p>* If computer still fails to operate after checking these suggestions, contact us for technical support.</p>
PRODUCT WILL NOT SIT LEVEL	<ol style="list-style-type: none"> 1) USE LEVELERS ON THE BOTTOM OF THE STABILIZERS TO ADJUST EQUIPMENT TO UNEVEN SURFACES.
SEAT POST MOVEMENT	<ol style="list-style-type: none"> 1) MAKE SURE THE ADJUSTMENT KNOB IS LOCKED INTO A SEAT POST HOLE. 2) SECURELY TIGHTEN THE SEAT POST IN PLACE BY TURNING THE ADJUSTMENT KNOB.
PEDAL WOBBLE	<ol style="list-style-type: none"> 1) CHECK TO MAKE SURE PEDALS ARE INSTALLED CORRECTLY (ORIENTATION) AND MOUNTED FLUSH WITH THE CRANK ARMS. 2) LOOSEN THE PEDALS, CHECK FOR POSSIBLE CROSS-THREADING OF CRANK ARMS.
NO SPEED READING	<ol style="list-style-type: none"> 1) CHECK COMPUTER CONNECTION: MAKE SURE CONNECTORS ARE SECURE AND IN THE CORRECT ORIENTATION. 2) CHECK SPEED SENSOR. CONFIRM CABLE CONNECTION AND ALIGNMENT WITH MAGNET.

Make sure to reference the assembly steps & parts information in this manual when performing any troubleshooting.

If you experience other technical problems that are not listed or have additional questions, please contact the original retailer or call us at 1-888-678-2476.

EQUIPMENT MAINTENANCE

Use a dampened soft-cloth to wipe equipment free of perspiration after each use. Avoid getting excessive moisture on computer or electronic components. Do not use abrasive cleaners or petroleum-based solvents to clean equipment.

Do not remove drive train shrouds or attempt any technical service on equipment without consulting an authorized service representative.

Regularly inspect product for loose assembly hardware and worn components.

(If applicable) For added safety, unplug equipment from the wall socket when it is not being used.

Use a product /exercise mat underneath equipment for protection of floors & carpets.

(If applicable) Apply recommended component lubricants at the required time periods.

Keep product assembly manual, purchase receipt, and service records in a safe storage place.

(If applicable) Periodically check batteries for proper voltage output & replace as needed.

Do not store or use equipment outdoors.

Moving equipment:

Lift up the rear stabilizer and carefully tip the bike forward until the front stabilizer wheels touch the floor. **Do not** use the computer or pivot arms to move the unit. You may wish to lock the fan in place (which will keep the arms from moving), by turning the safety knob (referenced on page 7) until it makes contact with the fan wheel.

TRAINING FOR SUCCESS

How you start an exercise program depends on your physical condition. If you have been inactive for awhile or you have pre-existing health condition, you should start slowly. Initially you may only be able to exercise for a short amount of time using minimal resistance levels or weight loads.

Begin your desired training program slowly and gradually increase the amount of time you exercise. Apply realistic goals, that have been set by you or your physician. You should see sufficient gains in your personal fitness level within 6-8 weeks of continuous exercise, but do not be discouraged if it takes longer. It is very important to exercise at your own pace and become confident in obtaining your goals. It is also important to apply warm-up, stretching, and cool down periods with any exercise program.

As your fitness level increases, so will your confidence and sense of accomplishment. Regular exercise and a healthy diet will energize you and offer a sense of well-being.

Full Terms & Conditions

All StairMaster® exercise products are warranted to be free from defects in materials and workmanship under the terms of recommended use and warranty coverage.

Warranty coverage is valid to the original retail purchaser and is not transferable. Coverage will be calculated from the date of retail purchase. Original proof of purchase and serial number identification will be required with any associated warranty claim.

Coverage periods & warranty terms may vary per product model. Applied warranties will be based on type of product, components, and recommended application (use environment). Products sold or placed in non-recommended user applications will void all warranty coverage set forth by StairMaster.

Coverage Periods

StairMaster hereby extends the following limited warranties for the application, components, and time periods indicated:

User Environment:	Residential	Light Commercial
Structural Frame:	10 years (limited)	5 years (limited)
Mechanical Parts:	3 years	2 years
Electronic Parts:	1 year	1 year
Wear Items*:	6 months	6 months
Labor**:	1 year	1 year

*Wear items are those components that may need replacement based on normal wear & tear conditions (i.e. cables, upholstery, grips, etc.).

**Labor coverage excludes unauthorized repairs, service calls, and non-warranty related charges.

Exclusions & Limitations

Applied warranties are exclusive to StairMaster. Warranty coverage will not extend to any product not purchased from StairMaster or from an authorized reseller.

Warranty coverage is void and will not extend to: a) use of product in non-recommended environments ; b) invalid claims and / or; c) any damage, failure or loss due to improper assembly / installation, improper maintenance, negligence, misuse, unauthorized repair, alteration, accident, normal wear & tear, or an ACT OF GOD.

Except as expressly set forth in the stated warranty terms StairMaster makes no other warranties, expressed or implied including, but not limited to, any implied warranties of merchantability and fitness for a particular purpose. Any implied warranties that may be imposed by law are limited to the terms stated within StairMaster® product warranties. Neither StairMaster nor any of its affiliates will be responsible for incidental or consequential damages.

Some states do not allow limitations on how long an implied warranty lasts or the exclusion or limitation of incidental or consequential damages, so the preceding exclusions or limitations may not apply. The stated warranty gives you specific legal rights and you may have other rights that vary state to state. StairMaster neither assumes or authorizes anyone to assume for it any other express warranty.

Exclusive Remedies

For any product that fails to conform to the limited warranty, StairMaster will provide, at their option, one of the following: 1) repair or replacement of defective parts, or 2) replacement of equipment with a product of equal value; 3) limited credit reimbursement toward another StairMaster® product.

Service Procedure

Obtain warranty service by contacting StairMaster or the original place of product purchase. Warranty service will be performed by the original reseller or an authorized service provider.

All warranty claims must be validated and meet the requirements set forth by StairMaster. Warranty claims will include confirmation of model number, serial number, and all pertinent information supporting the existence of an alleged defect.

All non-warranty related service cost will be the sole responsibility of the purchaser.

Purchaser is responsible for all transportation of product to and from the reseller. Service calls & travel fees are not covered under standard warranty labor and are the responsibility of the purchaser.

Unauthorized repairs, service performed by someone other than an authorized service provider, and / or use of unapproved replacement parts will void warranty coverage.

Note to Authorized Warranty Service Providers:

Warranty labor reimbursement or warranty parts rights may not be transferred or reassigned to a third party service provider without the authorization of StairMaster.

Product Registration

Fill out the enclosed warranty registration form and return to StairMaster within 30 days of product purchase. You can also register your product online. Along with product registration, keep copies of all product information for your personal records.

Product Information

Model: _____ **Purchase Date:** _____

Serial Number: _____

Contact Information:

Address: **StairMaster**
4400 NE 77th Ave, Suite 300
Vancouver, WA 98662, USA

Phone: **1-888-678-2476**

Email: **parts@stairmaster.com**
services@stairmaster.com



Thank you for purchasing a StairMaster® product. Our products are designed and manufactured to the highest quality standards. We are committed to our customers satisfaction and we will do everything we can under the conditions of your product warranty to keep you secure in your product purchase. To help us serve you better, please fill out this Product Registration form & return it to us within 30-days of product purchase.

Send completed registration form to: **StairMaster**
8000 NE Parkway Drive, Suite 220
Vancouver, Washington 98662

<p>Your Name _____</p> <p>Address _____ Apt. # _____</p> <p>City _____</p> <p>State _____ Zip Code _____</p> <p>Phone Number: _____</p> <p>Email Address: _____</p> <p>PRODUCT INFORMATION</p> <p>Model: _____</p> <p>Product Type: _____ <small>(Home Gym, Upright Bike, Free Weight etc.)</small></p> <p>Serial Number: _____</p> <p>Date of Purchase: _____ <small>(Month / Day / Year)</small></p> <p>Purchased From: _____ <small>(Retailer Name)</small></p> <p>Address: _____</p> <p>SURVEY</p> <p>A) How did you learn about our products?</p> <p>1. <input type="checkbox"/> Recommendation of personal trainer</p> <p>2. <input type="checkbox"/> Recommendation of retail salesperson</p> <p>3. <input type="checkbox"/> Recommendation of friend / relative</p> <p>4. <input type="checkbox"/> Article in magazine / newspaper</p> <p>5. <input type="checkbox"/> Internet</p> <p>6. <input type="checkbox"/> TV / radio</p> <p>7. <input type="checkbox"/> other: _____</p>	<p>B) Please note all factors that influenced your product purchase:</p> <p>1. <input type="checkbox"/> Valued priced</p> <p>2. <input type="checkbox"/> Quality / durability</p> <p>3. <input type="checkbox"/> Brand name</p> <p>4. <input type="checkbox"/> Design / look / feel</p> <p>5. <input type="checkbox"/> Strength training</p> <p>6. <input type="checkbox"/> Cardiovascular fitness</p> <p>7. <input type="checkbox"/> Weight loss</p> <p>8. <input type="checkbox"/> Home fitness convenience</p> <p>C) Rate the overall in-home assembly of the product:</p> <p><input type="checkbox"/> Fair <input type="checkbox"/> Average <input type="checkbox"/> Excellent</p> <p>D) Rate the satisfaction with the retailer from which you purchased your product:</p> <p><input type="checkbox"/> Fair <input type="checkbox"/> Average <input type="checkbox"/> Excellent</p> <p>E) What other types of exercise equipment do you own?</p> <p>1. <input type="checkbox"/> Treadmill</p> <p>2. <input type="checkbox"/> Stepper</p> <p>3. <input type="checkbox"/> Elliptical</p> <p>4. <input type="checkbox"/> Home Gym</p> <p>5. <input type="checkbox"/> Upright bike</p> <p>6. <input type="checkbox"/> Recumbent bike</p> <p>7. <input type="checkbox"/> Free weights</p> <p>8. Other: _____</p> <p>F) What product features / functions are most important to you?</p> <p>1. <input type="checkbox"/> Heart rate monitoring</p> <p>2. <input type="checkbox"/> Multiple user programs</p> <p>3. <input type="checkbox"/> Ease of use</p> <p>4. <input type="checkbox"/> Quality / durability</p> <p>5. <input type="checkbox"/> Comfort / fit / feel</p> <p>6. <input type="checkbox"/> Design / appearance</p> <p>7. <input type="checkbox"/> Ease of assembly</p> <p>8. <input type="checkbox"/> Warranty & service</p> <p>9. <input type="checkbox"/> Brand recognition</p> <p>10. Other: _____</p> <p>G) How many times a week do you exercise?</p> <p><input type="checkbox"/> 1-2 times <input type="checkbox"/> 3-4 times <input type="checkbox"/> 4-5 times <input type="checkbox"/> 6-7 times</p> <p>H) What is the duration of your workout?</p> <p><input type="checkbox"/> 20-30 minutes <input type="checkbox"/> 1-2 hours <input type="checkbox"/> 2 hours or more</p> <p>I) Age Group:</p> <p><input type="checkbox"/> 18-25 <input type="checkbox"/> 26-35 <input type="checkbox"/> 36-45 <input type="checkbox"/> 46-55 <input type="checkbox"/> 56-65 <input type="checkbox"/> 66 & older</p> <p>J) Gender: <input type="checkbox"/> Male <input type="checkbox"/> Female</p> <p>K) Type of use: <input type="checkbox"/> Personal <input type="checkbox"/> Spouse <input type="checkbox"/> Family</p> <p>L) Do you belong to a health club, gym, wellness center, etc.?</p> <p><input type="checkbox"/> Yes <input type="checkbox"/> No</p>
--	--

Thank you ! We appreciate your response. The information provided on this questionnaire is used exclusively by StairMaster and will not be distributed to any other individuals or agencies regardless of purpose.

Safety Recommendations: Consult a physician or health professional before starting any type of exercise program. Warm up and stretch before starting a exercise routine. Inspect your product for proper assembly. Make sure all assembly hardware is tightened appropriately. Check cables and all moving parts for smooth movement and full range of motion. If you are unsure of proper use of your purchased product, contact a local retailer or call us for instruction. Equipment is not designed for the use of children or minors. Failure to follow or apply these suggested safety tips may result in serious injury.

✂ Please Cut Along This Line ✂

StairMaster
8000 NE Parkway Drive, Suite 220
Vancouver, WA 98662
1-888-678-2476



www.stairmaster.com