



# User Manual

## MHD44TP

PTN HDBaseT Matrix Switchers 4x4



**All Rights Reserved**

Version: MHD44TP20131.0



**NOTICE:** Please read this user manual carefully before using this product.

This manual is only for operation instruction only, not for any maintenance usage. The functions described in this version are updated till May 2013. Any changes of functions and parameters since then will be informed separately. Please refer to the dealers for the latest details.

This manual is copyright PTN Electronics Limited. All rights reserved. No part of this publication may be copied or reproduced without the prior written consent of PTN Electronics Limited.

**All product function is valid till 2013-05-29.**

### Update History

Version	Date	Update Content
1.0	2013.05.29	First version.



---

## **Table of Contents**

1. Introduction .....	1
1.1 Introduction to MHD44TP .....	1
1.2 Features .....	1
1.3 Package Contents .....	1
2. Introduction of Product Appearance.....	2
2.1 Front Panel of MHD44TP .....	2
2.2 Rear Panel of MHD44TP .....	3
2.3 Connection with RS232 Communication Port.....	4
2.4 Twisted Pair Cable Connection.....	5
3. System Connection.....	5
3.1 Usage Precautions .....	5
3.2 System Diagram .....	6
3.3 Connection Procedure.....	6
3.4 System Applications .....	7
4. Application Solution .....	7
5. System Operations .....	9
5.1 Usage of IR Remote .....	9
5.2 RS232 Control .....	10
5.3 USB Firmware Updating.....	12
6. Specification .....	13
7. Panel Drawing .....	14
8. Troubleshooting & Maintenance .....	15
9. Safety Operation Guide .....	16
10. After-sales Service .....	17



# 1. Introduction

## 1.1 Introduction to MHD44TP

MHD44TP is a 4x4 HDBaseT matrix switcher, including 4 HDMI inputs, 4 HDBaseT outputs, 2 local HDMI outputs, 4 de-embedded stereo audio & 4 de-embedded digital audio outputs. It enables cross-point switching from any input to any output, and supports high resolution 1080P, HD3D. The HDBaseT output works with TPHD402PR, to transmit HDMI, IR, RS232 and POE over a Cat5e/Cat6 cable. And its transmission distance can up to 60 meters.

## 1.2 Features

- HDTV compatible with High Definition Transmission resolution up to 1920\*1200@60Hz, support 1080P, HD3D.
- HDCP Compliant and DVI compatible, supporting DVI1.0.
- Powerful EDID&HDCP management.
- HDBaseT outputs, to transmit HDMI, IR&RS232 to 60 meters long distance over a Cat5E/6 cable.
- POE supports, provides power for all the receivers connected to HDBaseT outputs.
- Supports multiple control ways, including front panel, RS232, IR and optional TCP/IP control (works with PTNET).
- IR OUT signal switching follow with video signal, also can be broken away from video switching.
- Supports remote control from receiver by IR&RS232.
- Supports centralized IR control to control all the remote display devices.
- Supports PCM, Dolby, and DTS5.1 surround.
- LCD indicator shows connection status, switching status, HDCP status, and output resolution.

## 1.3 Package Contents

- 1 x MHD44TP
- 2 x Mounting ears
- 1 x Power adapter (DC48V)
- 1 x IR remote
- 1 x Power cord
- 1 x RS232 cable
- 1 x CAT5e twisted pair
- 8 x Captive screw connectors
- 4 x Plastic cushions
- 1 x User manual

**Notes:** Please confirm if the product and the accessories are all included, if not, please contact with the dealers.

## 2. Introduction of Product Appearance

### 2.1 Front Panel of MHD44TP

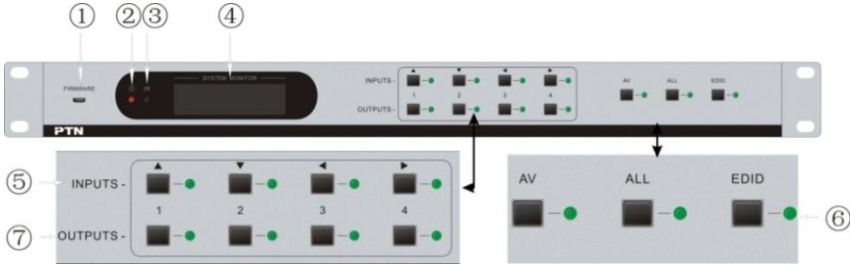

Figure 1 Front Panel of MHD44TP

No.	Name	Description
①	Firmware	Micro USB port for update firmware.
②	Power Indicator	Keep light when power on.
③	IR Receiver	Receive control signal from IR remote.
④	LCD Indicator	Real-time shows system status.
⑤	INPUTS/ Menu buttons	Normal mode: Input buttons, ranging from "1" to "4". Inquire mode: Press "AV" more than 3 seconds to enter this mode. ◀▶ to change different menus, ▲▼ to change different channels.
⑥	Function buttons	> <b>AV</b> synchronal button: To transfer AV and IR signal synchronously by the switcher. <b>Example:</b> To transfer both AV and IR signals from input channel No.1 to output channel No.3. <b>Operation:</b> Press buttons in this order "1", "AV", "3".
		> <b>ALL</b> outputs button: To transfer one input to all outputs. <b>Example:</b> To transfer both AV and IR signals from input channel No.1 to all output channels. <b>Operation:</b> Press buttons in this order "1", "ALL"
		> <b>EDID</b> management button: manually capture and copy the EDID data from output device to input port. <b>Example:</b> To capture and copy the EDID data from output channel No.4 to input channel No.2. <b>Operation:</b> Press buttons in this order "EDID", "2", "4"
⑦	OUTPUTS	Output buttons, ranging from "1" to "4".



With the front control panel, the switcher could be control directly and rapidly by pressing the buttons under below format.

- “Input Channel” + “AV” + “Output Channel”
- “Input Channel”: Fill with the number of input channel to be controlled.
- “Output Channel”: Fill with the number of output channels to be controlled.

### 2.2 Rear Panel of MHD44TP

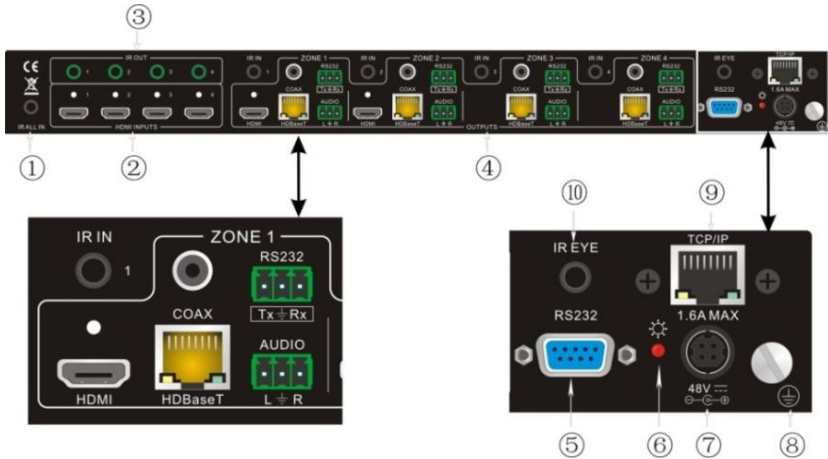

Figure 2 Rear Panel of MHD44TP

No.	Name	Description
①	IR ALL IN	IR control signal input port, connect with IR receiver, pass through to all the HDBaseT ports to control the remote devices.
②	HDMI INPUTS	Type A female HDMI connectors.
③	IR OUT	Connect with IR transmitter, to send out the IR signal from the HDBaseT port. These IR OUTs make up a IR matrix with the IR INs on the HDBaseT receivers, and all can be switched synchronously with the AV signal, or separately switching.
④	OUTPUTS	<p><b>IR IN:</b> Connect with IR receiver, fixed IR input for the output, cannot be switched. It makes up an IR transmission with the IR OUT on the corresponding HDBaseT receiver.</p> <p><b>HDMI:</b> Split HDMI output for local monitoring.</p> <p><b>COAX:</b> HDMI de-embedded digital audio output.</p> <p><b>HDBaseT:</b> Works with receivers using HDBaseT technology, such as TPHD402R, TPHD402PR. It can</p>

		pass through AV, IR and RS232 signal to 60m distance. Meanwhile, it can provide power for the receivers which support POE. <b>RS232:</b> RS232 port to communicate with the RS232 port on corresponding HDBaseT receiver. <b>AUDIO:</b> HDMI de-embedded stereo audio output
⑤	RS232	The serial port for unit control, 9-pin female connector.
⑥	Power Indicator	Keep light when power on.
⑦	48V DC	Connect with 48V DV power adaptor.
⑧	GROUND	Connect to grounding, make the unit ground well.
⑨	TCP/IP	TCP/IP port for unit control, optional function.
⑩	IR EYE	Connect with extended IR receiver, use the IR remote to control MHD44TP.

### 2.3 Connection with RS232 Communication Port

Except the front control panel, MHD44TP can be controlled by far-end control system through the RS232 communication port. This RS232 communication port is a female 9-pin D connector. The definition of its pins is as the table below.

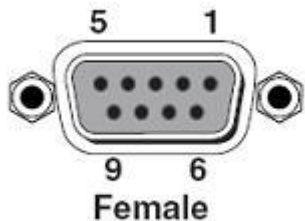

No.	Pin	Function
1	N/u	Unused
2	Tx	Transmit
3	Rx	Receive
4	N/u	Unused
5	Gnd	Ground
6	N/u	Unused
7	N/u	Unused
8	N/u	Unused
9	N/u	Unused

### 2.4 Twisted Pair Cable Connection

The cables for HDBaseT ports must be through ones, using T568A or T568B standard.

TIA/EIA T568A		TIA/EIA T568B	
Pin	Cable color	Pin	Cable color
1	green white	1	orange white
2	green	2	orange
3	orange white	3	green white
4	blue	4	blue
5	blue white	5	blue white
6	orange	6	green
7	brown white	7	brown white
8	brown	8	brown
1st Ground	4--5	1st Ground	4--5
2nd Ground	3--6	2nd Ground	1--2
3rd Group	1--2	3rd Group	3--6
4th Group	7--8	4th Group	7--8

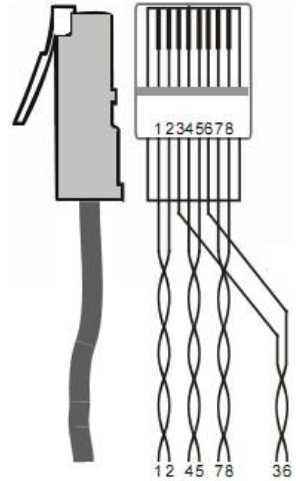

## 3. System Connection

### 3.1 Usage Precautions

- 1) System should be installed in a clean environment and has a prop temperature and humidity.
- 2) All of the power switches, plugs, sockets and power cords should be insulated and safety.
- 3) All devices should be connected before power on.

### 3.2 System Diagram

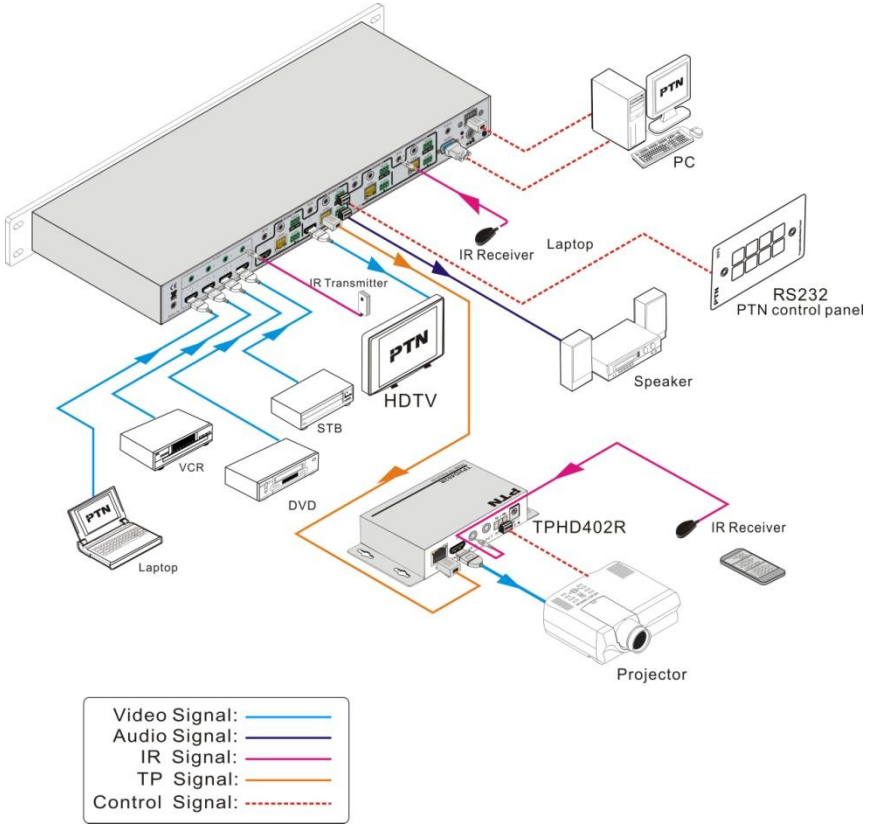

Figure4 System Diagram

### 3.3 Connection Procedure

- Step1.** Connect HDMI sources (such as DVD players) to HDMI input ports of MHD44TP with HDMI cables.
- Step2.** Connect HDMI displays (such as HDTV) to HDMI output ports of MHD44TP with HDMI cables.
- Step3.** Connect speakers or earphones to AUDIO output ports (3p captive screw connectors).
- Step4.** Connect the HDBaseT port of TPHD402R (Receiver) and MHD44TP with twisted pair.
- Step5.** Connect the RS232 port of control device and the 9 pin female D RS232 port of MHD44TP with RS232 cable.
- Step6.** Connect the RS232 port of controlled device to any other RS232 port (3p captive

screw connector) of MHD44TP. The control signal can be transmitted bi-directionally.

**Step7.** MHD44TP can be controlled by its built-in IR receiver or through the IR EYE port by connecting with external IR receiver. The IR signal can also be transmitted bi-directionally (connect IR OUT port of MHD44TP to IR IN port of other far-end IR device, and connect IR IN ports of MHD44TP to IR OUT port of other far-end IR device), and in this mode, we can control MHD44TP remotely.

**Step8.** Connect DC48V power adaptors to MHD44TP.

### 3.4 System Applications

As its good performance in control and transmission, MHD44TP can be widely used in computer realm, monitoring, large screen displaying, conference system, television education and bank securities institutions etc.

## 4. Application Solution

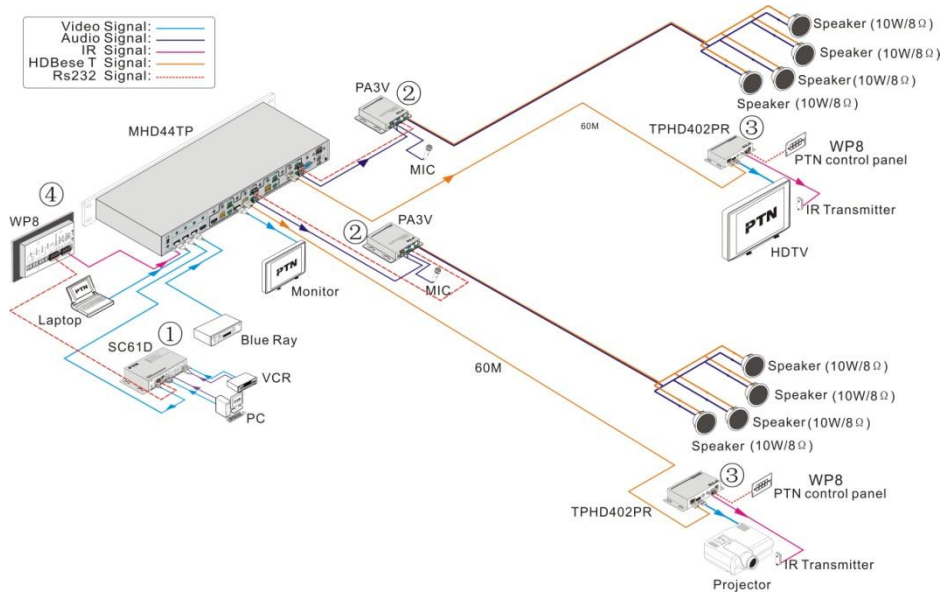

**Figure 5 Solution Diagram**

Product Assortment Description:

**① SC61D (mini scaler switcher)**

- 6 video Inputs: 2 x HDMI, 1 x VGA, 1 x YPbPr, 1 x C-video & 1 x S-video.
- Upscale to HDMI output at 1080P.
- 3 audio outputs: HDMI embedded audio, 3.5mm stereo audio and Coaxial (SPDIF).

- Output resolutions selectable to assure preferred output.
- Output display H/V size: adjustable to settle any overscale problem.
- Output display H/V position moveable.
- Picture/MP3 display via USB.
- Video parameter setting and preset.
- Powerful OSD function with full control, support output freeze function
- Ultra-switching for instantaneous display.
- HDMI1.3 and HDCP compatible.
- Firmware updatable via USB.
- Front panel lockout.

② **PA3V (40W power amplifier)**

- Mono audio output at 40Watt.
- Switchable between 70V and 100V.
- Ducking function.
- 16 ID codes for controlling between different PA3V amplifiers.
- 3-level MIC input, supports condenser microphone, dynamic microphone and wireless microphone.
- MIC port can support balance/unbalance signal, suppress the external noise effectively.
- Two stereo audio inputs and one digital audio input, switchable by button, IR remote & RS232.
- Volume/Bass/Treble controllable by buttons, IR remote & RS232.
- Fast switching speed for good performance.
- Convection cooler, fan is not needed.

③ **TPHD402P (HDMI/IR/RS232 POE twisted pair extender)**

- Support Full HD: Delivers high resolution image (1080p@60Hz@48 b/pixels/3D/4Kx2K).
- Max transmission distance is up to 70 meters over single CAT5e/CAT6 cable.
- HDTV Compatible, use HDMI 1.4 and HDCP compliant.
- Support POE & CEC.
- Connect with a displayer to transmit EDID and HPD signals constantly by using a CAT5e cable.
- Use HDBaseT technology.
- Bi-directional RS232/IR control.

④ **WP8 (control panel)**

- Every button can be programmed to send the bi-direction RS232 and RS485 commands simultaneously to control third party devices.
- Every button can be programmed to send the infrared code, control the relay, to let them work simultaneously to control the third party devices.
- Every button is built in the infrared code and RS232 code learning function, and baud-rate setting.

- ID looping function. 99pcs WP8 can be looped and controlled together, by ID identifying.
- Programmed by USB or RS232, working with PTN PC software (PS-WP).
- Crystal and backlit buttons with easy user-friendly customizable changeable labels.
- The backlit brightness is controllable.
- Dimension: 11.4cm long and 7cm wide.

## 5. System Operations

### 5.1 Usage of IR Remote

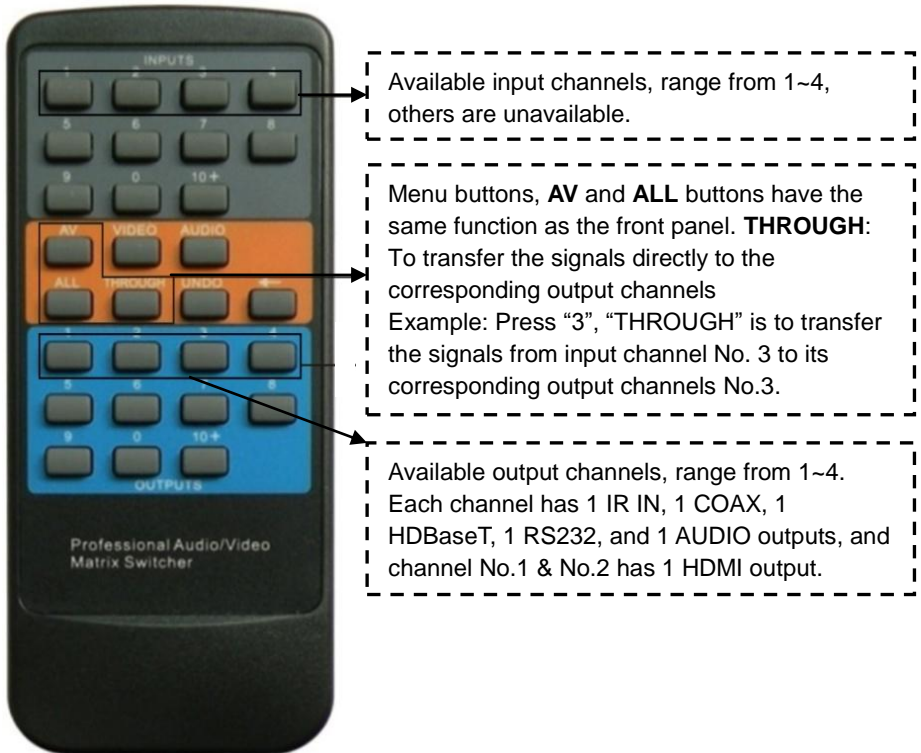

**Figure 6 IR Remote**

MHD44TP can be controlled by its built-in IR receiver or through the IR EYE port by connecting with external IR receiver, or even can be controlled remotely by a far-end IR device through the twisted pair.

## 5.2 RS232 Control

**Communication protocol:** RS232 Communication Protocol

Baud rate: 9600

Data bit: 8

Stop bit: 1

Parity bit: none

Command Types	Command Codes	Functions
System Command	/*Type;	Inquire the models information.
	/%Lock;	Lock the keyboard of the control panel on the Matrix.
	/%Unlock;	Unlock the keyboard of the control panel on the Matrix.
	/^Version;	Inquire the version of firmware
	/:MessageOff;	Turn off the feedback command from the com port. It will only show the “SWITCH OK”.
	/:MessageOn;	Turn on the feedback command from the com port.
	Demo.	Switch to the “demo” mode, 1->1, 2->2, 3->3 ... and so on .The switching interval is 2 seconds.
	Undo.	To cancel the previous operation.
Operation Command (PTN2.0 Command System)	[x]All.	Transfer signals from the input channel [x] to all output channels
	All#.	Transfer all input signals to the corresponding output channels respectively.
	All\$.	Switch off all the output channels.
	[x]#.	Transfer signals from the input channel [xq] to the output channel [x].
	[x]\$.	Switch off the output channel [x].
	[x1] V[x2].	Transfer the AV signal from the input channel [x1] to the output channel [x2].
	[x1] B[x2].	Transfer the AV and IR signal from the input channel [x1] to the output channel [x2].
	Status.	Inquire the input channel to the output channels one by one.
	Save[X].	Save the present operation to the preset command [X], ranges from 0 to 9.
	Recall[Y].	Recall the preset command [Y].
	Clear[Y].	Clear the preset command [Y].
	PWON.	Work in normal mode.
PWOFF.	Enter into standby mode.	



<p>/%[Y]/[X]:[Z].</p>	<p>HDCP management command. [Y] is for input (value: I) or output (value: O). [X] is the number of one port, if the value of X is ALL, it means all ports. [Z] is for working status (Value: 1 or 0).</p> <ul style="list-style-type: none"> <li>➤ Y=I &amp; Z=1, means the input port is compliant with HDCP.</li> <li>➤ Y=O &amp; Z=1, means output with HDCP.</li> <li>➤ Y=I &amp; Z=0, means the input port is not compliant with HDCP.</li> <li>➤ Y=O &amp; Z=0, means output without HDCP.</li> </ul>
<p>%0801.</p>	<p>Automatically HDCP management.</p>
<p>%0800.</p>	<p>Manually HDCP management.</p>
<p>[x1] R[x2].</p>	<p>Transfer the IR signal from the input channel [x1] to the output channel [x2].</p>
<p>/+[Y]/[X]:*****.</p>	<p>Set communication between PC and TPHD402R.</p> <ul style="list-style-type: none"> <li>➤ [Y] is for port number</li> <li>➤ [X] is for bound rate (Value ranges from 1 to 7, 1 is for 2400, 2 for 4800, 3 for 9600, 4 for 19200, 5 for 38400, 6 for 57600 and 7 for 115200)</li> <li>➤ ***** is for data (max 48 Byte, the symbol “.” Is unavailable)</li> <li>➤ Note: when the value of Y is 5, it means that to send data to all 4 ports synchronously.</li> </ul>
<p>%9971.</p>	<p>Check the connection status of the inputs.</p>
<p>%9972.</p>	<p>Check the connection status of the outputs.</p>
<p>%9973.</p>	<p>Check the HDCP status of the inputs.</p>
<p>%9974.</p>	<p>Check the HDCP status of the outputs.</p>
<p>%9975.</p>	<p>Check the switching status.</p>
<p>%9976.</p>	<p>Check the output resolution.</p>
<p>EDIDG[x].</p>	<p>Get EDID data from the output and display the output port number of X.</p>
<p>EDIDMInit.</p>	<p>Recover the factory default EDID data.</p>

	EDIDM[X]B[Y].	Manually EDID switching. Copy the EDID data of output[X] to the input[Y].
	EDIDUpgrade[x]	Upgrade EDID data via the RS232 port [X] is for input port, when the value of X is 5, it means to upgrade to all input ports. When the switcher gets the command, it will show a message to send EDID file (.bin file). Operations will be canceled after 10 seconds. (Note 1)

**Note:**

1. Please disconnect all the HDBaseT cables before sending command EDIDUpgrade[X].
2. In above commands, “[” and “]” are symbols for easy reading and do not need to be typed in actual operation.
3. Please remember to end the commands with the ending symbols “.” and “;”.
4. Type the command carefully, it is case-sensitive.

**5.3 USB Firmware Updating**

To meet with the request of different users or add function in future, the firmware of MV4 can be upgraded via USB. When you need to upgrade it, please download the latest upgrade file and then you are able to upgrade it through the update EXE software. Copy the EXE software to the PC in controlled and double click the program to upgrade the firmware.

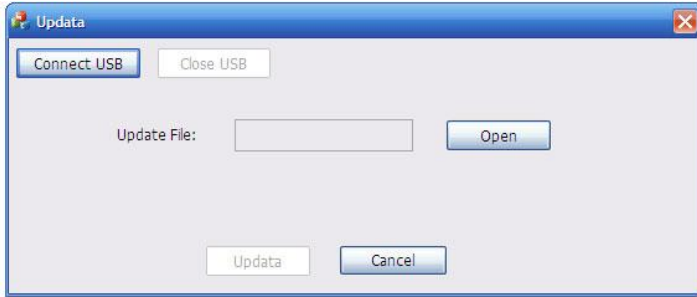

**Figure 7 Update EXE Software**

When the program is running normally, it will enter in to the interface (as shown in next

figure), please press the button  and choose the upgrade file downloaded,

and then press the button . It is ready to upgrade. When all are done, it will appear with a window shows the message Update success.



**Figure 8 Interface of Update EXE Software**

**Note:** The COM number connected with PC is available only when in 1 to 9.

## 6. Specification

Video Input		Video Output	
Input	4 HDMI	Output	2 HDMI 4 HDBaseT
Input Connector	Female HDMI	Output Connector	Female HDMI Female RJ45(with LED indicators)
Input Level	T.M.D.S. 2.9V/3.3V	Output Level	T.M.D.S. 2.9V/3.3V
Input Impedance	100Ω (Differential)	Output Impedance	100Ω (Differential)
Video General			
Gain	0 dB	Bandwidth	6.75Gbit/s
Video Signal	HDMI (or DVI-D)	Maximum Pixel Clock	165MHz
Resolution Range	Up to 1920 x 1200 or 1080P@60Hz	Switching Speed	200ns (Max.)
Transmission Distance	60m with POE		
EDID Management	In-built EDID data and manual EDID management		
HDCP	Supports HDCP 1.3, auto and manual HDCP management.		
Audio General			
Output Signal	Stereo audio Digital audio	Output Connector	4 3p captive screw connectors 4 Coax (RCA)
Stereo Output	Earphone output distortion: 0.1%	Coax Output	Supports PCM, Dolby, DTS 5.1

	32Ω/70mW@1KHz , 0.1% 16Ω/105mW @1KHz		
Frequency Response	20Hz~20KHz	CMRR	>90dB @20Hz ~ 20KHz
<b>Control Parts</b>			
Control Ports	4 IR OUT (green) 4 IR IN (black) 1 IR EYE (black) 1 TCP/IP (female RJ45) 1 RS232 (9 pin female D) 4 RS232 (3p captive screw connectors)	Panel Control	Front panel buttons
IR	Default IR remote Extend IR EYE	TCP/IP Control	Works with PTNET2.2
<b>General</b>			
Power Supply	Input: 100VAC ~ 240VAC, 50/60Hz Output:DC48V,1.6 A	Power Consumption	48W
Temperature	-20 ~ +70℃	Humidity	10% ~ 90%
Case Dimension	W483 x H44 x D235mm (1U high, full rack wide)	Product Weight	1.8Kg

### 7. Panel Drawing

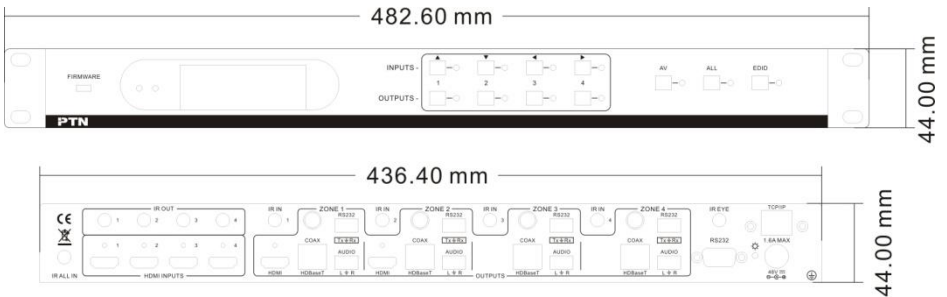

## 8. Troubleshooting & Maintenance

- 1) When there is a color losing or no video signal output, maybe the cables have already broken or haven't been connected well.
- 2) When EDID management does not work normally, probably the HDMI cable is broken at the output end.
- 3) When switching, there is a blank screen on the displayer, maybe the displayer does not support the resolution of the video source. Switch again or manage the EDID data manually to make the resolution of the video source automatically compliant with the output resolution.
- 4) When user cannot control the switcher by computer through its COM port, please check the COM port number in the software, and make sure the COM port is in good condition and the communication protocol is correct.
- 5) When switching , there is no output image:
  - Check if there is any signal at the input.
  - Check if there is any signal at the output.

If there is no signal input/output, maybe the input/output cables broken or the connectors loosen, please change for another cable.
  - Check if the output port number is the same with the controlled one.
  - If it is still the same after the above checking, maybe there is something wrong in the switcher. Please send it to the dealer for repairing.
- 6) If the static becomes stronger when connecting the video/audio connectors, it probably due to bad grounding, please check the grounding and make sure it connected well; otherwise it would damage the switcher.
- 7) If the switcher cannot be controlled through the RS232 port, front panel buttons or by the IR remote, the unit may have already been broken. Please send it to the dealer for repairing.

## **9. Safety Operation Guide**

In order to guarantee the reliable operation of the equipments and safety of the staff, please abide by the following proceeding in installation, using and maintenance:

- 1) The system must be earthed properly. Do not use two blades plugs and ensure the alternating power supply ranged from 100v to 240v and from 50Hz to 60Hz.
- 2) Do not put the switcher in a place of too hot or too cold.
- 3) As the power generating heat when running, the working environment should be maintained fine ventilation, in case of damage caused by overheat.
- 4) Cut off the general power switch in humid weather or left unused for long time.
- 5) Before following operation, ensure that the alternating current wire is pull out of the power supply:
  - Take off or reship any components of the equipment.
  - Take off or rejoin any pin or other link of the equipment.
- 6) As to non-professional or without permission, please DO NOT try to open the casing of the equipment, DO NOT repair it on your own, in case of accident or increasing the damage of the equipment.
- 7) DO NOT splash any chemistry substance or liquid in the equipment or around.

## 10. After-sales Service

- 1) If there appear some problems when running MHD44TP, please check and deal with the problems reference to this user manual. Any transport costs are borne by the users during the warranty.
- 2) You can email to our after-sales department or make a call, please tell us the following information about your cases.
  - Product version and name.
  - Detailed failure situations.
  - The formation of the cases.
- 3) We offer products for all three-year warranty, which starts from the first day you buy this product (The purchase invoice shall prevail).
- 4) Any problem is same with one of the following cases listed, we will not offer warranty service but offer for charge.
  - Beyond the warranty.
  - Damage due to incorrectly usage, keeping or repairing.
  - Damage due to device assembly operations by the maintenance company non-assigned.
  - No certificate or invoice as the proof of warranty.
  - The product model showed on the warranty card does not match with the model of the product for repairing or had been altered.
  - Damage caused by force majeure.

**Remarks:** For any questions or problems, please try to get help from your local dealer, or to email PTN at: [support@PTN-electronics.com](mailto:support@PTN-electronics.com).



[www.PTN-electronics.com](http://www.PTN-electronics.com)

**PTN Electronics Limited**

**Tel:** +86-755-2846 1819

**Fax:** +86-755-8471 7796

**Email:** [info@PTN-electronics.com](mailto:info@PTN-electronics.com)

**Website:** [www.PTN-electronics.com](http://www.PTN-electronics.com)



2 013062 806013