

Installation and Operation Manual

MOUNTAIN SERIES

Stone Hearth Oven
Wood-Fired Model



MT. CHUCKANUT

WS-MS-4-W

MT. ADAMS

WS-MS-5-W

MT. BAKER

WS-MS-6-W

MT. RAINIER

WS-MS-7-W

WoodStone

WOOD STONE CORPORATION

1801 W. Bakerview Rd.
Bellingham, WA 98226 USA

Toll Free (800) 988-8103

Tel (360) 650-1111

Fax (360) 650-1166

www.woodstone-corp.com

Revised September 2009



TABLE OF CONTENTS

MOUNTAIN SERIES-----	2
UNLOADING AND MOVING -----	4
INSTALLATION CLEARANCES -----	5
FACADE DETAILS -----	7
OUTDOOR INSTALLATIONS -----	8
OVEN VENTING -----	9
FLUE ADAPTER -----	12
TEMPERATURE READOUT -----	13
MANTLE MOUNTING -----	14
STUCCO FINISH APPLICATION -----	15
INITIAL STARTUP -----	16
MANAGING THE OVEN FIRE -----	17
SAFETY CONSIDERATIONS -----	18
CARE AND CLEANING -----	19
FUELWOOD FACTS-----	20
LIMITED WARRANTY -----	21



**INSTALLATION AND OPERATION MANUAL
THE WOOD STONE MOUNTAIN SERIES**

STONE HEARTH COOKING EQUIPMENT

WS-MS-(4, 5, 6, 7)-W

WOOD-FIRED OVEN

ADDITIONAL COPIES AVAILABLE UPON REQUEST

READ ALL INSTRUCTIONS BEFORE INSTALLING AND USING THIS APPLIANCE

**A MAJOR CAUSE OF OVEN RELATED FIRES IS FAILURE TO
MAINTAIN REQUIRED CLEARANCES (AIR SPACES) TO COMBUSTIBLE
MATERIALS. IT IS OF THE UTMOST IMPORTANCE THAT THIS OVEN BE
INSTALLED ONLY IN ACCORDANCE WITH THESE INSTRUCTIONS.**



WOOD STONE MOUNTAIN SERIES WOOD-FIRED OVEN OPERATING INSTRUCTIONS DO NOT THROW THIS MANUAL AWAY

RETAIN THIS MANUAL FOR FUTURE REFERENCE

Additional copies of this manual and prompt responses to service/maintenance questions are available from Wood Stone @ 1-800-988-8103.

**WHEN THE OVEN IS NOT PROPERLY INSTALLED, A FIRE MAY RESULT.
TO REDUCE RISK OF FIRE, FOLLOW THE INSTALLATION INSTRUCTION.**

FOR YOUR SAFETY

Do not store or use gasoline or other flammable vapors or liquids in the vicinity of this or any other appliance. Also, always keep the area under and around this appliance free and clear of any and all combustible materials.

It is recommended that this oven be installed, maintained and serviced by authorized professionals.

WARNING: Improper installation, adjustment, alteration, service or maintenance can result in property damage, injury or death. Read the installation, operation and maintenance instructions thoroughly before installing or servicing this equipment.

Wood Stone's wood-fired ovens have been tested and approved by Intertek Testing Services (ETL SEMKO) and are ETL Listed to UL Subject 2162 and ULC Subject 1482-M1990, and to ANSI/NSF Standard 4.



Please read this entire manual before you install the oven. Failure to follow instructions may result in property damage, bodily injury or even death. Contact your local building or fire officials about restrictions and installation inspection in your area.



LIFTING THE OVEN

1. USING A CRANE

The oven arrives with four lifting eyes attached. When craning a Wood Stone oven, use a spreader bar with a two-legged sling rigged on each end. The spreader bar should be of a sufficient length to keep the sling from contacting the oven.

NOTE: Once lifting eyes are no longer needed, remove the lifting eyes one at a time and be sure to replace the bolts that attach the oven to the stand.

2. USING A FORKLIFT

Be sure to use a forklift rated to lift more than the oven weighs as shown below. Fork length must be at least 6 feet, if not, fork extensions should be used. The oven stand is equipped with fork pockets just above the angle iron base. The oven is very top heavy so spread the forks as far apart as possible.

3. USING A PALLET JACK

Once the oven has been removed from the delivery vehicle, it can easily be moved on flat surfaces using a pallet jack. To lift the oven with a pallet jack, remove the front and rear angle iron stabilizers from the base of the oven stand and place a stout 4x4 post through the fork pocket as shown. **THE OVEN IS VERY TOP-HEAVY, MOVING THE OVEN UP OR DOWN A RAMP ON A PALLET JACK IS NOT SAFE!**

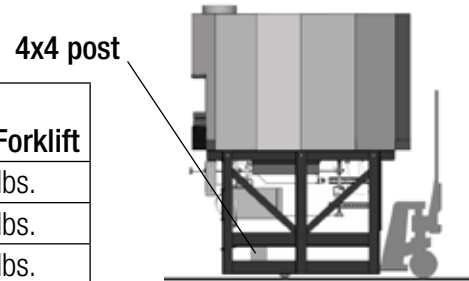
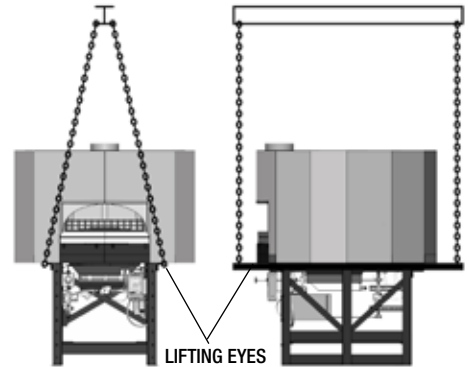

Model #	Oven	Approximate Weight	Minimum Fork Length Required	Required Forklift
WS-MS-4	Mt. Chuckanut	2,400 lbs.	4'	5,000 lbs.
WS-MS-5	Mt. Adams	3,600 lbs.	5'	6,000 lbs.
WS-MS-6	Mt. Baker	4,600 lbs.	6'	6,000 lbs.
WS-MS-7	Mt. Rainier	6,000 lbs.	7'	9,000 lbs.

DO NOT TURN THE OVEN ON ITS SIDE!

New MS series ovens have been designed to allow the oven to be turned on its side. **HOWEVER-CONTACT THE FACTORY BEFORE PROCEEDING TO VERIFY THAT YOUR OVEN CAN BE TURNED ON ITS SIDE**, and for instructions on how to do so. **WE STRONGLY RECOMMEND THAT YOU ENLIST THE SERVICES OF A QUALIFIED RIGGER FOR THIS PROCEDURE!**

Contact Wood Stone if the oven must be turned on its side for specific instructions. Moving a Wood Stone oven can present interesting challenges to even the most experienced riggers. Take your time, use your head, secure the proper equipment and make safety your first priority. Please don't hesitate to call the factory for technical support (1-800-988-8103).

DELIVERY NOTE: The customer will receive an Oven Shipping Notification when the oven leaves the Wood Stone factory. This will include a PRO# and a trucking company contact number. Wood Stone recommends that you confirm the delivery date/time with the trucking company before committing to heavy equipment and/or labor. Our goal is a smooth and safe delivery. Thank you.



IF THIS OVEN IS NOT PROPERLY INSTALLED A FIRE MAY RESULT. TO REDUCE THE RISK OF FIRE, FOLLOW THESE INSTALLATION INSTRUCTIONS. A MAJOR CAUSE OF OVEN RELATED FIRES IS FAILURE TO MAINTAIN REQUIRED CLEARANCES (AIR SPACES) TO COMBUSTIBLE MATERIALS. IT IS OF UTMOST IMPORTANCE THAT THIS OVEN BE INSTALLED ONLY IN ACCORDANCE WITH THESE INSTRUCTIONS.



WARNING: Installation and servicing of this product could expose you to glasswool/ceramic fibers as well as Calcium Silicate dust. **ALWAYS WEAR RESPIRATORY AND EYE PROTECTION WHEN INSTALLING OR SERVICING THIS APPLIANCE.** Please read this entire manual before you install the oven. Failure to follow instructions may result in property damage, bodily injury or even death. Contact your local building or fire officials about restrictions and installation inspection in your area.

CLEARANCES

- a. The Wood Stone ovens are (per ETL listings) approved for 1" clearance to combustibles on the sides and back of the unit. Any combustible facade or surround installed around the oven must maintain a 1" air space between it and the outer shell of the oven. An air space of 14" is required between the top of the unit and any combustibles.
- b. **WARNING: DO NOT PACK REQUIRED AIR SPACE WITH INSULATION OR OTHER MATERIALS.** The oven is fully insulated at the factory and requires no additional insulation.
- c. Install this oven only on a non-combustible floor surface. The non-combustible floor surface should extend 36" out in front of the oven, and extend 30" to either side of the oven doorway.
- d. Any facade above the doorway of the oven and 6" to either side of the doorway must be constructed of non-combustible building materials such as metal, plaster, tile, etc.
- e. If the space between the legs of the stand is used for wood storage, it is recommended that it be a covered container or box to prevent the possibility of sparks or embers from making contact with the stored wood. An 8-1/2" (eight and one-half inch) air space clearance is required between the bottom of the oven and any wood storage container.
- f. When utilizing a combustible material to construct the enclosure, all openings within 30" of either side of the door opening, floor to ceiling, must be sealed to prevent the entry of sparks or embers. Wood-fired ovens must be installed on non-combustible floor surface AND provided with a non-combustible floor covering at least 30" to each side of door opening and 36" in front of the door opening.

NOTICE: FOR STUCCO COVERED OVENS (MODEL NUMBERS ENDING IN 'S'), 36" CLEARANCE TO COMBUSTIBLE BUILDING MATERIALS IS REQUIRED. *When non-combustible building materials contact the body of the oven, the clearances to combustibles are transferred to those non-combustibles.

Please read this entire manual before you install the oven. Failure to follow instructions may result in property damage, bodily injury or even death. Contact your local building or fire officials about restrictions and installation inspection in your area.



THE FOLLOWING CLEARANCE INFORMATION APPLIES TO ALL WOOD STONE MOUNTAIN SERIES (NON-STUCCO) OVENS

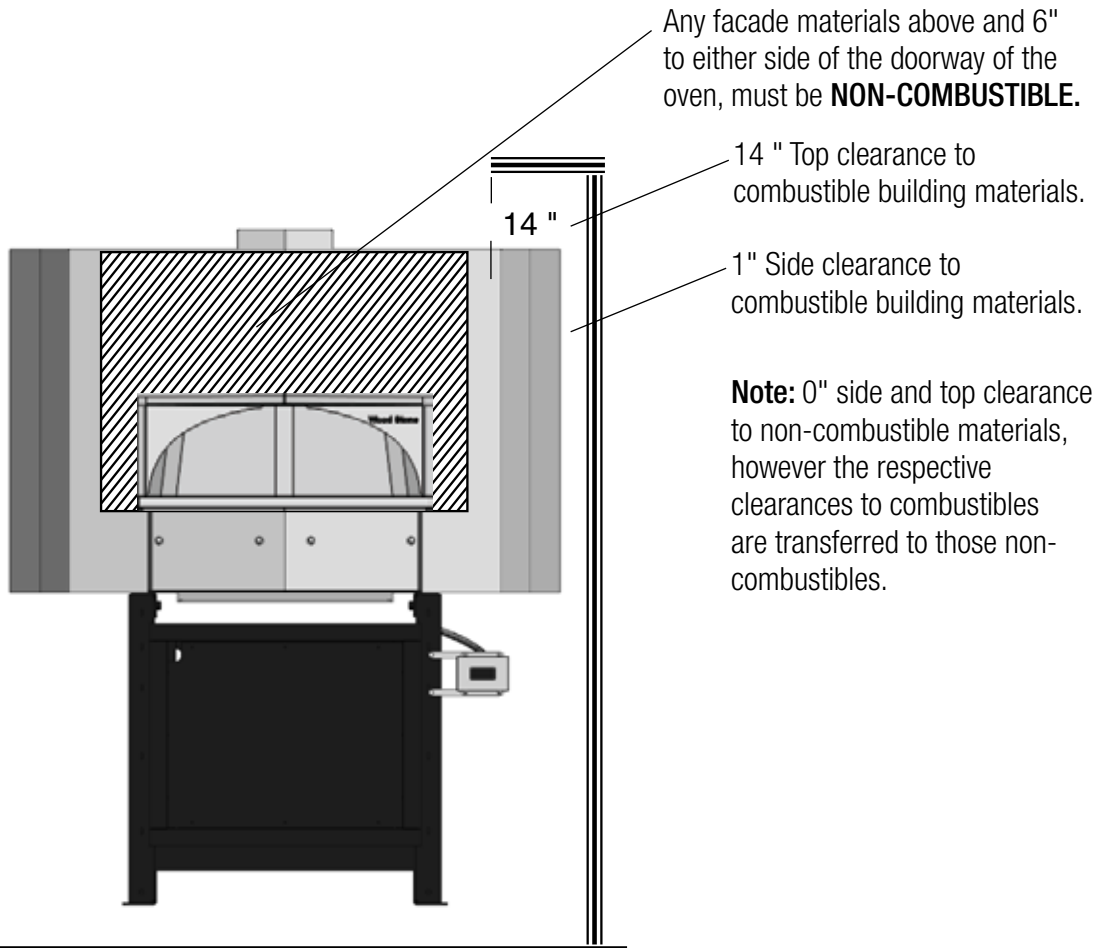

ALL STUCCO OVENS REQUIRE A 36" CLEARANCE TO COMBUSTIBLE BUILDING MATERIALS.



Wood Stone Mountain Series (MS-Models) ovens carry an ETL Sanitation listing. The oven interior only is ETL listed to NSF/ANSI Standard 4. This means that the surfaces of the oven which are meant to be left exposed after the facade has been put in place, have been evaluated from the standpoint of sanitation and food safety and found to comply with NSF/ANSI Standard 4. To operate the oven in accordance with NSF/ANSI Standard 4, only pizza and bread products may be cooked directly on the floor of the oven. Other types of food may be cooked on or in pans, or other suitable containers to prevent spillage onto the oven deck.

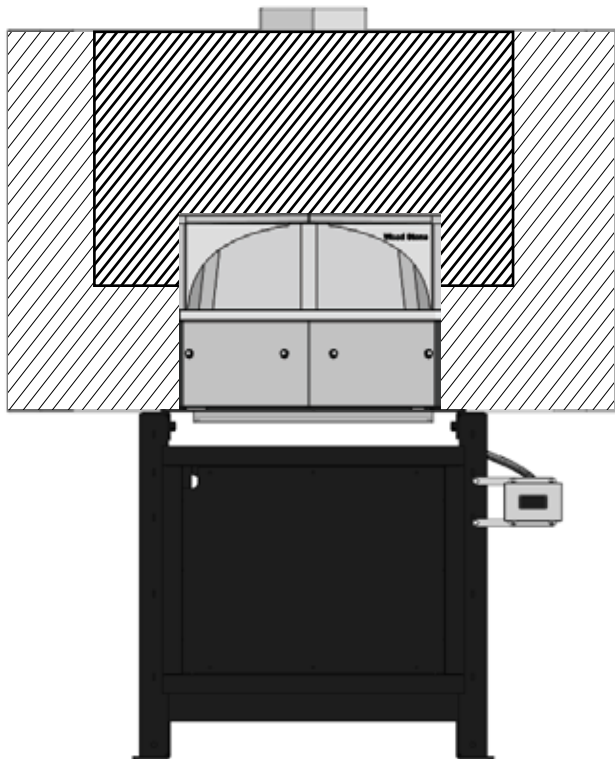

If using an exhaust hood over the oven, make sure your facade allows for the proper access for removal of the hood filters!

Go to www.woodstone-corp.com for detailed instructions for constructing a facade around a Wood Stone Oven.

IMPORTANT NOTE: If enclosing the oven in a facade, you must leave an access panel to allow for service of the thermocouple beneath the oven. Wood Stone's oven mounted wood box has an access panel built in.

 Hatched areas shall not be exposed after installation of facade.

 Any facade above and/or within 6" to either side of the doorway must be constructed of non-combustible building materials



OUTDOOR INSTALLATIONS

The Mountain Series (MS and MH) model ovens are ETL approved for outdoor installation. When installed outdoors, the open area beneath the oven must be enclosed. The oven may be installed in a weatherproof enclosure. If so be sure to maintain all clearances and adhere to the installation requirements included in this manual.

**KEEP THE AREA AROUND AND BENEATH THE OVEN CLEAR OF GRASS, LEAVES,
AND OTHER COMBUSTIBLE MATERIALS.**



THIS OVEN MUST BE VENTED AS A SOLID FUEL APPLIANCE

The following are the manufacturer's recommendations for venting the Wood Stone MS (Mountain Series) -W (wood-fired) ovens. It is never appropriate to use "B vent" in any part of an exhaust system connected to a Wood Stone oven. All ducting material must be manufactured to the specifications of a grease duct and a listed building heating appliance chimney. This is a wood-fired oven and must be vented as a solid fuel piece of equipment. Due to the possibility of sparks entering the system, exhaust systems serving solid fuel equipment must be vented separately from other non-solid fuel equipment. Submit your venting plans to your local authorities before proceeding with your installation, as there may be additional requirements in your area. The duct serving this solid fuel oven should be inspected at least twice a month during the first two months of operation, to establish rate of creosote buildup and necessary cleaning schedule. If creosote or soot has accumulated, it should be removed to reduce the risk of a flue fire.

THERE ARE THREE OPTIONS:

1. Direct Connection: A listed building heating appliance chimney, also listed as a grease duct as described in NFPA 96, connected directly to the oven flue collar and provided with a power ventilator listed for restaurant appliance exhaust. The power ventilator should be rated for a minimum of 450 degrees Fahrenheit (F). Wood Stone does not recommend the use of an in-line fan. A field built grease duct, constructed and installed to the specifications of a grease duct as detailed in NFPA 96 or the International Mechanical Code, may also be used.

A static pressure of -0.14 inches water column is necessary at the oven flue collar to ensure that flue gas temperatures do not exceed 450 degrees F at the fan inlet. The CFM required to attain this static pressure will depend on the configuration of your particular installation but will probably be between 500 and 700 CFM. Wood Stone provides a port in the flue collar of the oven for insertion of a magnehelic gauge. This enables the installer to monitor the draft to ensure proper operation of the venting system. This measurement may also be taken by inserting the end of the probe through the oven doorway, upwards to the oven flue collar. **NOTE:** Double door ovens (Models ending in DD), have two flue collars, both must be connected and a static pressure of -0.14 inches must be maintained at each collar.

NOTE: If your MS-5, MS-6, or MS-7 oven is ordered from Wood Stone without a hood, it will have a round flue adapter installed to facilitate direct connection to a round duct. If the oven is to be installed under a hood, it MAY be necessary to remove the round adapter to properly position the hood. This is done by removing the screws that attach the adapter to the oven. Please contact Wood Stone if you have any questions.

OVEN MODEL SERIES		FLUE COLLAR I.D. (NOMINAL)
Mt. Adams	WS-MS-5	10 inch
Mt. Baker	WS-MS-6	10 inch
Mt. Rainier	WS-MS-7	10 inch

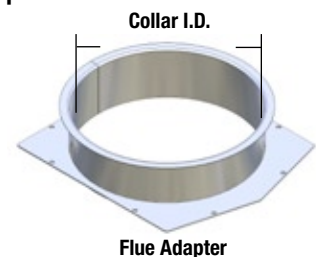

NOTE: MS-4 ovens come standard with a round 8" O.D. collar and do not require the flue adapter for a direct connection.

Install venting system in accordance with the duct manufacturer's instructions and in accordance with all local codes. All field built components should be built to the applicable codes and standards and are subject to the approval of the authority having jurisdiction.



INSTALLATION VIEWS OF A WOOD STONE HOOD

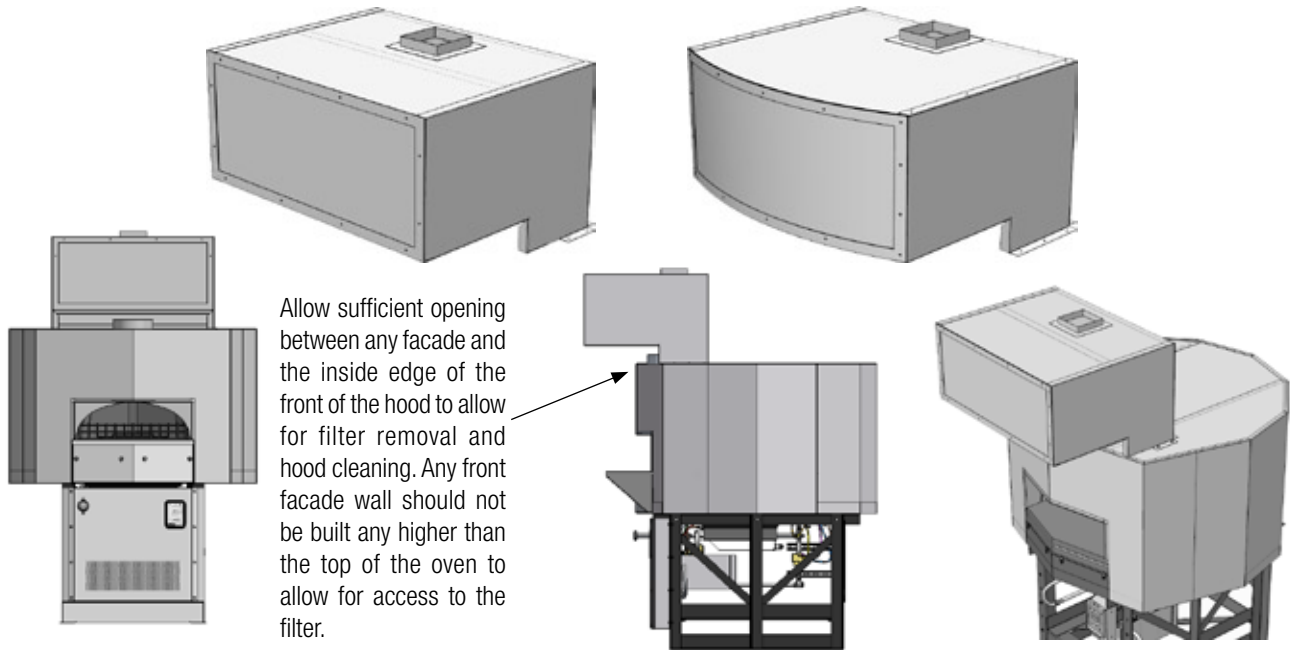

2. A Listed Type 1 Exhaust Hood or one that is constructed and installed in accordance with all relevant Local and National Codes. Wood Stone offers eyebrow-type hoods designed specifically for Wood Stone ovens. See specification sheet on ventilators for Wood Stone ovens.

Note that the notch of the hood is even with the front edge of the oven. The hood should be installed in accordance with the hood manufacturer's instructions, and with NFPA 96 and/or the applicable local and national codes.

3. Exhaust from Wood Stone gas-fired ovens (RFG models) can be vented using one of the previously mentioned methods OR can be combined with exhaust from other equipment, assuming the common duct meets the construction requirements listed in #1. If the Wood Stone oven is installed using the direct connect method, and is going to be tied into a common duct that is connected to any hoods; the system must be engineered so that the duct pressure at the oven flue collar is -0.1 inches W.C. (-0.14 inches W.C. for solid fuel models). Failure to properly engineer the venting system will severely compromise oven performance and reliability. Tying a direct connected Wood Stone oven into a common duct may not be a feasible solution for many installations. In these cases the oven must either be vented separately, or vented using a Type 1 hood.

It is never appropriate to use "B vent" in any part of an exhaust system connected to a Wood Stone oven. All ducting material must be manufactured to the specifications of a grease duct. Due to the possibility of sparks entering the duct, exhaust systems serving solid fuel equipment **MUST** not be combined with exhaust systems serving other (non-solid fuel) equipment. This model is rated as solid fuel equipment and must be vented as such.



VERY IMPORTANT! WOOD STONE RECOMMENDS THAT YOU SUBMIT YOUR VENTING PLANS TO LOCAL CODE AUTHORITIES BEFORE PROCEEDING WITH INSTALLATION.

FIRE SUPPRESSION

Check with your local code officials to see if fire suppression is required in your area. If fire suppression is required, you must vent the oven using a Type 1 hood constructed and installed in accordance with NFPA 96. The fusible link in the hood must be rated at 450 degrees F minimum. Wood Stone offers UL Listed Exhaust Hoods for our ovens that are pre-piped for ANSUL R-102 fire suppression. All installations are subject to the approval of the local authority having jurisdiction.



MOUNTAIN SERIES OVENS -- FLUE ADAPTER

The flue adapter unit is designed to facilitate connection to a round duct. Use the stainless steel screws provided to attach the flue adapter to the exhaust outlet on the oven.

NOTE: If using a Selkirk or other modular-type duct, attach according to the manufacturer's instructions. Otherwise, the duct must be attached with a full perimeter weld. If attaching to Selkirk duct, order the Selkirk Installation kit from Wood Stone. All duct must be grease-rated duct. If the oven is going to be enclosed, the flue adapter and exhaust outlet must be wrapped with an insulating material approved for use with a grease-duct.

Flue adapter

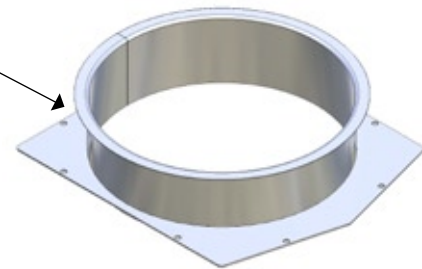

FLUE ADAPTER -- shown attached to oven flue collar

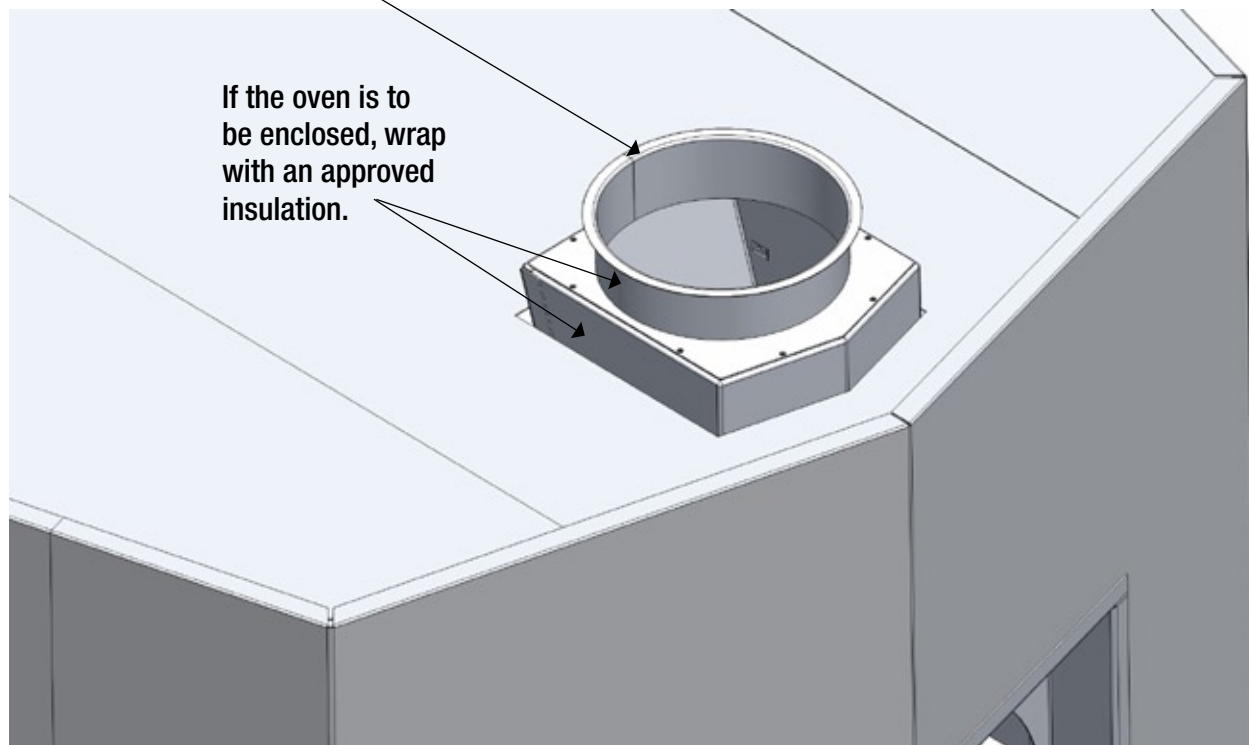



DIGITAL TEMPERATURE READOUT

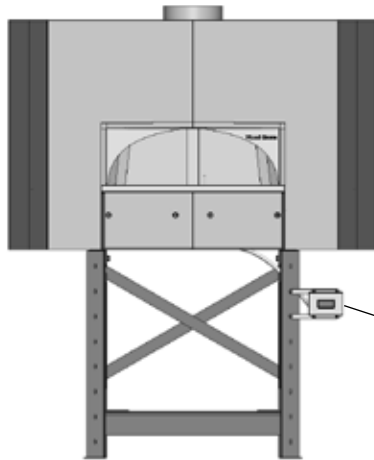

Location of digital readout

The temperature sensor (thermocouple) is factory mounted in the ceramic floor of the oven. The thermocouple cable runs through flexible conduit and is factory connected to the thermometer readout which is mounted to the stand of the oven. Extra conduit is provided to allow the thermometer box to be mounted to the oven facade instead or to the oven if so desired.

IMPORTANT NOTE: If enclosing the oven in a facade, you must leave an access panel to allow for service of the thermocouple. Wood Stone's oven mounted wood box has an access panel built in.

Wood Stone does not supply an electrical power cord. The power cord or direct connection is to be supplied by others and connected by a licensed electrician.

TO MAKE THE ELECTRICAL CONNECTION TO THE THERMOMETER READOUT:

Remove the (4) screws holding the stainless steel faceplate to the readout box and gently pull back the faceplate. The standard oven model comes configured for connection to a 120 VAC circuit. The oven can be ordered configured for connection to a 240 VAC circuit. Have a licensed electrician install the appropriate circuit through the vacant hole in the back of the stainless steel readout enclosure. Attached to the backside of the faceplate is the readout and a 120V/12V (or 240V/12V) step down transformer. Connect the incoming power supply to the transformer primary leads. Ground the incoming power supply using the green screw on the rear inner wall of the stainless enclosure.

NOTES:

- Be sure that the face plate is replaced right-side-up.
- There is no need to disconnect the conduit when relocating the digital readout.
- The mounting brackets for the stainless steel digital readout enclosure can be removed and remounted to accommodate the needs of various installations.
- Take care not to pull on the conduit or thermocouple wires.

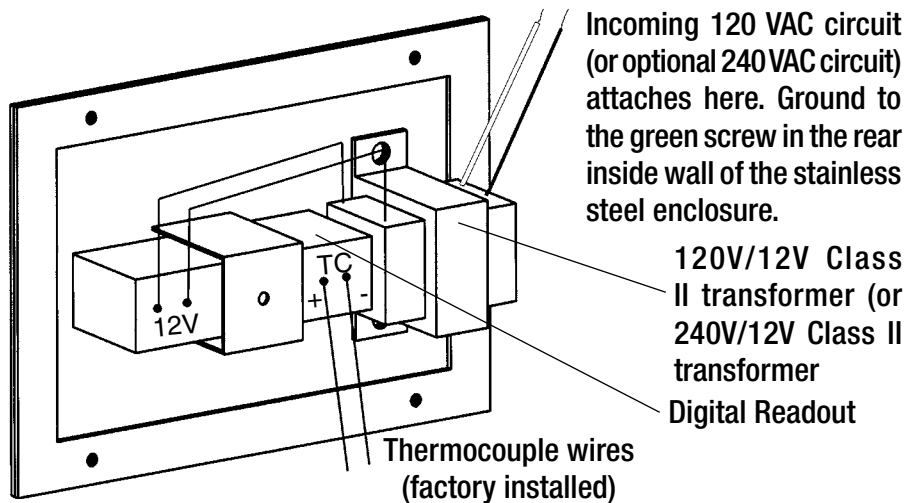



The initial steps are the same for mounting either a stainless mantle or a bracket for a granite mantle.

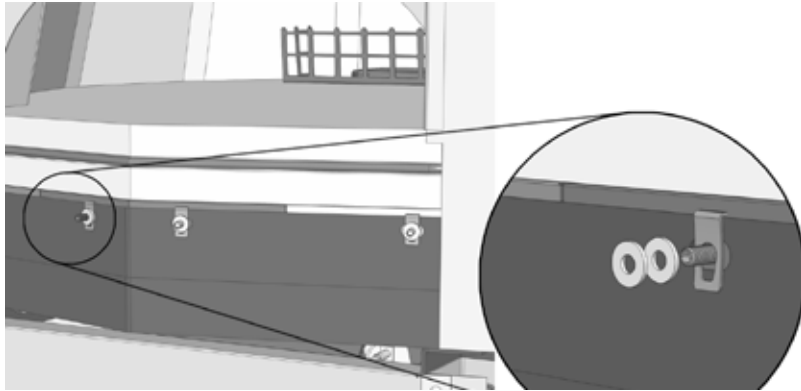

1. Begin by installing the threaded studs into the clip nuts below the oven doorway (3 or 4 turns is sufficient).

2. Next, place (2) spacer washers on each stud.

3. Position the mantle (or bracket) on the oven, make sure the rear flange rests on the floor of the oven (you may need an extra pair of hands).

4. Finally, place one final washer (stainless steel) and a cap nut on each stud. Tighten the cap nuts so the mantle is securely held in place.

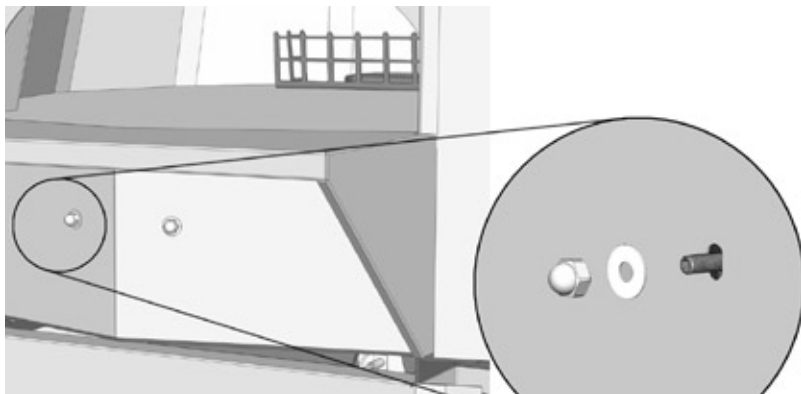

5. Using the high temperature silicone (provided), fill any gaps between the oven hearth and the mantle flange. Gaps between the mantle flange and the stainless steel doorway frame may also need to be filled with a small amount of the silicone compound.

INSTALLATION OF GRANITE - After completing the steps outlined above, apply a generous amount of silicone adhesive (provided) to the top of the steel mantle bracket.



Put the stone in place and apply light pressure to seat it properly. Make sure that the angle in the granite lines up with the angle in the bracket. Allow the adhesive to set for several hours before filling any gap between the stone slab and the metal bracket with the silicone compound (provided). Clean up any adhesive and/or silicone before it dries!

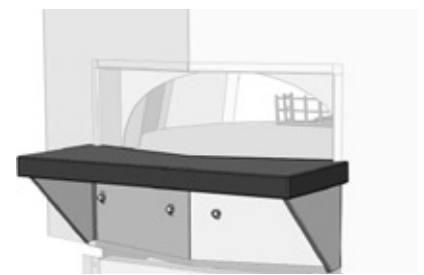



INSTALLING THE WOOD STONE 'S' MODEL (STUCCO FINISHED) WOOD-FIRED OVEN

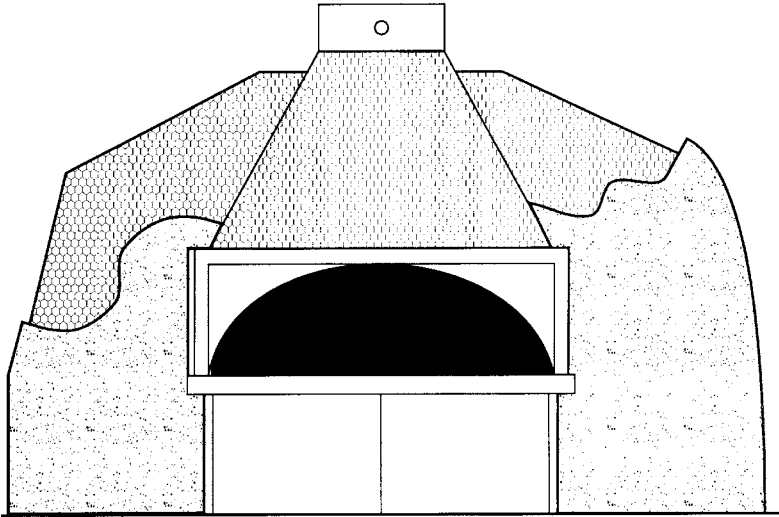

Front View

NOT TO SCALE

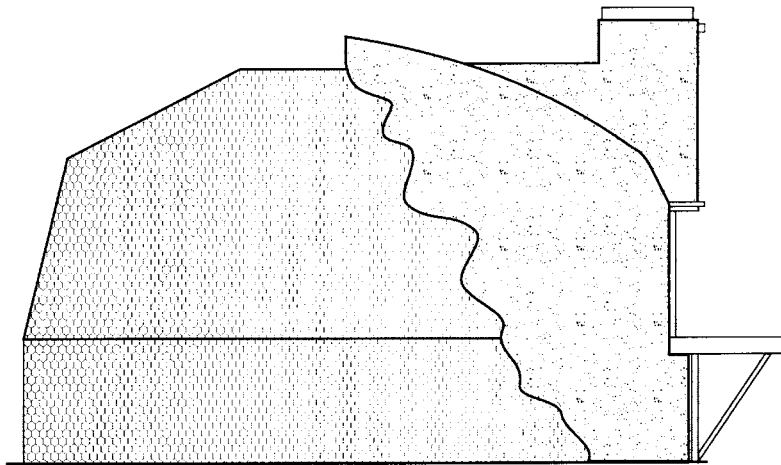

Side View

NOT TO SCALE

TRADITIONAL STUCCO MIX

1 part masonry cement
1 part regular cement
5 parts sand

STUCCO PREMIX IS PROBABLY AVAILABLE AT YOUR LOCAL LUMBER YARD OR BUILDING SUPPLY STORE

1 part premix
2 parts sand

MINIMUM STUCCO APPLICATION IS 1"

This figure depicts the application of stucco on a Wood Stone oven. Use no less than one inch of stucco coating to cover all exposed metal lathing on the oven. Maintain a minimum of 36" clearance from top and sides of oven to all combustible surfaces.



READ BEFORE BUILDING FIRST FIRE

THIS OVEN HAS BEEN FACTORY-CURED, HOWEVER SLOW WARMING IS STILL NECESSARY TO ENSURE EQUAL DISTRIBUTION AND SATURATION OF HEAT WITHIN THE DOME AND HEARTH. THIS PROCESS IS ALSO NECESSARY TO PREVENT THERMAL SHOCKING OF THE REFRACTORY STONE, WHICH CAN CAUSE EXCESSIVE CRACKING.

DAY ONE

1. Build a small kindling fire of newspaper and 5-7 lbs. of heavy, hard wood. We suggest using a "Fire Starter" (paraffin/sawdust stick) to start the fire. Begin with (3) small pieces of wood (about 1"-3" diameter and 14"-16" in length). Build the fire directly on the floor of the oven against the side or back of the dome. The fire should be built far enough inside and of a size that doesn't permit the flame to go up the flue. Slowly bring the oven temperature up to 300-400 degrees F. Maintain this fire for 4-5 hours.

2. Once the oven temperature has reached 300-400 degrees F, increase the oven temperature by increasing the size and amount of wood being used. Based on what is already burning, gradually increase the amount of wood per hour. This will bring the oven temperature up to 500-550 degrees F.

NOTE: THE MORE WOOD ADDED TO THE FIRE, THE HOTTER THE OVEN WILL GET

It is recommended that on the first day of heat-up, the oven does not exceed 550 degrees F within the first 8 hours. If your goal is to cook at higher temperatures, the oven should only be brought up to 550 degrees F on day one. Once the oven has reached the 550 degrees F, more wood may be added to the fire as necessary to bring the oven to the desired operating temperature. The amount of wood required to bring the oven to the specified temperatures may vary depending on the type and quality of the wood. **Never use any type of flammable liquid or fuel to start a fire in a Wood Stone oven. Doing so could cause a dangerous situation and/or damage to the oven ceramic.**

DURING THE FIRST FEW DAYS OF OPERATION, SMALL AMOUNTS OF WATER MAY APPEAR DRIPPING FROM THE OVEN. THIS IS NORMAL AND WILL STOP WITHIN A FEW DAYS.

IMPORTANT NOTES:

- One pound of properly cured, heavy, hard wood produces the potential of 6,500 Btu's.
- The temperature sensor (thermocouple) is located at the center of the floor, one inch under the surface. The thermocouple will give false readings if the fire is placed on top of it.
- If at anytime the oven is allowed to cool to room temperature for an extended period of time, especially outdoor installations, this heat-up procedure will need to be repeated to avoid thermal shocking of the refractory stone which can cause excessive cracking.
- Small "crazing" cracks will occur with normal heating and cooling. They will not effect the performance or durability of the oven. If cracks of 1/8" or more develop, contact Wood Stone for evaluation.

DO NOT POUR OR SPRAY LIQUIDS ONTO THE OVEN DECK OR INTO THE OVEN INTERIOR AS THIS CAN DAMAGE THE CERAMIC AND WILL VOID THE WARRANTY.



THE FIRE

Use only seasoned hardwoods with a moisture content of 20% or less. Use of soft woods, such as pine, cedar, hemlock etc., and wet or 'green' wood, will cause a build-up of residue throughout the exhaust system. (See Wood Stone's **Fuel Wood Facts**, or consult factory for information on what types of wood can be used for oven fuel.)

The fire should be ignited a couple of hours before the oven needs to be at cooking temperature, and can be located practically anywhere in the oven. Once the oven is being used daily, the fire can be ignited using still glowing coals from the previous day's fire. The oven is heated more evenly and effectively by the fire positioned on the side rather than in the rear of the oven. Adding about 5-7 lbs. of wood per hour should bring the oven temperature up about 100 degrees per hour (this will vary slightly depending on the type and moisture content of the wood and the size of the oven). The floor temperature is indicated by the digital thermometer and should not exceed 850 degrees. Once the desired temperature is reached, maintain it by addition of wood as needed. Do not toss or throw wood against back or side walls of oven - this may void the warranty. At the end of the work day, put removable stainless steel door(s) into door opening to hold heat in the oven overnight.

MANAGING THE FIRE / TEMPERATURE

These suggestions will normally produce an oven floor temperature of 500-600 degrees F. If you need to achieve higher temperatures, use a little more wood. For lower temperatures use a little less wood.

4' Oven: Maintain 1 log with 6-10" of open flame working on the coal bed.

5' and 6' Ovens: Maintain 1-1 1/2 logs with 8-12" of open flame working on the coal bed.

7' Oven: Maintain 1 1/2-2 logs with 8-14" of open flame working on the coal bed.

DO NOT OVER-FIRE THIS OVEN. IF FLAMES ARE SPILLING OUT OF THE DOOR OPENING, OR IF OVEN FLOOR TEMPERATURE EXCEEDS 850 DEGREES F, THEN YOU ARE OVER-FIRING THE OVEN.

ASH DISPOSAL: At the start of the following work day, push glowing coals out of the ash pile with 8" utility peel. Remove ash with ash shovel, leaving live coals to start the day's fire. Place ashes into metal container with a tight-fitting lid. The closed container of ashes should be placed on a non-combustible floor or on the ground, a safe distance from all combustible materials pending final disposal. They should be retained in the closed container until all cinders have thoroughly cooled. Check with your dealer about Wood Stone's Ash Dolly.

CAUTION: Never use gasoline, gasoline-type lantern fuel, kerosene, charcoal lighter fluid, or similar liquids to start or freshen a fire in this oven. Keep all such liquids away from the oven while it is in use.

DO NOT USE PRESSED WOOD PRODUCTS IN WOOD STONE FOOD SERVICE EQUIPMENT, AS THEY MAY DAMAGE THE CERAMICS.



REMOVAL OF CREOSOTE AND SOOT

As with all commercial cooking equipment exhaust systems, a regular inspection and cleaning schedule is needed to prevent the possibility of a hood or duct fire. The frequency of inspection and cleaning will depend on hours of use and type and quality of wood used as fuel. Only use hardwood species dried to a moisture content of 20% or less. See the **Fuel Wood Facts** Sheet at the end of this manual.

When wood is burned slowly, it produces tar and other organic vapors, which combine with expelled moisture to form creosote. The creosote vapors condense in the relatively cool oven flue of a slow-burning fire. As a result, creosote residue accumulates in the duct. When ignited, this creosote makes an extremely hot fire.

The duct serving this oven should be inspected at least twice a month during the first two months of operation, to establish rate of creosote buildup and necessary cleaning schedule. If creosote or soot has accumulated, it should be removed to reduce the risk of a flue fire.

The interior floor and dome of the oven do not require creosote or soot removal. The oven flue and exhaust system will require inspection and cleaning. The exhaust system should be inspected and cleaned per the manufacturer's and or local code official's recommendations.

DISPOSE OF ASH PER THE FOLLOWING:

1. Place ashes into a metal container with a tight fitting lid.
2. Place the closed container of ashes on a non-combustible floor or on the ground.
3. Place the closed container of ashes well away from all combustible materials, pending final disposal.
4. Retain the ashes in the closed container until all the cinders have thoroughly cooled. Ashes can then be disposed of safely.

NOTE: Wood Stone's stainless steel ash shovel and double compartment ash disposal system offer a safe and convenient way to dispose of ash.

DO NOT POUR OR SPRAY LIQUIDS ONTO THE OVEN DECK OR INTO THE OVEN INTERIOR AS THIS CAN DAMAGE THE CERAMIC AND WILL VOID THE WARRANTY.



CARE AND CLEANING

OVEN FLOOR: As needed, brush food particles and stray fire debris from the oven floor using a long-handled floor brush. If something spills on the floor of the oven, wait for it to burn and/or dry up and then clean the residue off with the floor brush. This process can be sped up by moving a small portion of coals onto the spill causing it to bake off quickly. For removal of fine particles (burned flour or ash), wrap a warm, damp cloth around the brush head and use it to briskly wipe the floor. Do not scrape the oven floor with metal tools having sharp edges or corners!

STAINLESS STEEL SURFACES: The oven tools, the mantle, the night doors and the oven doorway must be cleaned, as needed, using warm soapy water. Do not use abrasive metal scouring pads as they will scratch the stainless steel. Avoid the use of excess water when cleaning the face of the digital readout or oven controller.

DUCT: As with all commercial cooking equipment, regular cleaning and maintenance of the exhaust system is necessary to prevent the possibility of a hood and/or duct fire. The frequency of inspection and cleaning will depend upon hours of use and type and moisture content of the wood used for fuel.

AVOID FLUE FIRES; BURN GOOD QUALITY WOOD AND ESTABLISH A REGULAR CLEANING SCHEDULE!



WHAT TYPE OF WOOD SHOULD YOU USE TO FIRE YOUR SOLID FUEL COOKING EQUIPMENT?

The answer to this question depends on several considerations: geographical location, availability and relative cost of various fuelwood species and individual preferences regarding the flavor qualities of various wood types. There are a wide variety of good fuelwood species in all geographic locations. Each species of wood has different characteristics. The table below should help weigh the pros and cons of various types of wood. Wood from conifers (pine trees) is not recommended due to its poor fuelwood characteristics (low weight, low-med heat, poor coaling, high sparking and high residual creosote).

Wood Type	Heat	Lbs/Cord	Lighting	Coaling	Sparks	Fragrance*
Alder	Med-Low	2500	Fair	Good	Moderate	Slight
Apple	High-Med	4400	Fair	Excellent	Few	Excellent
Ash	High	3500	Fairly Difficult	Good-Excellent	Few	Slight
Beech	High	3800	Difficult	Excellent	Few	Good
Birch (white)	Medium	3000	Easy	Good	Moderate	Slight
Cherry	Medium	2000	Fair	Excellent	Few	Excellent
Elm	High	2300	Very Difficult	Good	Very Few	Fair
Hickory	Very High	4200	Fairly Difficult	Excellent	Moderate	Excellent
Maple (red)	High-Med	3200	Fairly Difficult	Excellent	Few	Good
Maple (sugar)	High	3700	Difficult	Excellent	Few	Good
Mesquite	Very High		Very Difficult	Excellent	Many	Excellent
Oak (live)	Very High	4600	Very Difficult	Excellent	Few	Fair
Oak (red)	High	3700	Difficult	Excellent	Few	Fair
Oak (white)	Very High	4200	Fairly Difficult	Excellent	Few	Fair
Pecan	High		Fair	Good	Few	Good

***The desirability of various fragrances is largely a matter of personal preference.**

Whichever type of wood you use, **MAKE SURE YOU KNOW THE MOISTURE CONTENT.** Properly seasoned wood contains 20% moisture or less. If wood contains more than 20% moisture, it should not be accepted for use. Wood should be stored off the ground and out of the rain in an environment that allows good air circulation so that the drying process can continue. Wet wood is the most common operational difficulty associated with wood-fired cooking equipment. Wood Stone's moisture meter can prevent you from paying for water when you thought you were paying for wood (see optional accessories).

Calculate your approximate monthly, daily and hourly fuel-wood costs using the following formulas:
The cost of well-seasoned hardwood varies greatly with geographical location.

$$\text{Cost per month} = A \times C \quad \text{Cost per day} = \frac{A \times C}{30} \quad \text{Cost per hour} = \frac{\left(\frac{A \times C}{30}\right)}{12}$$

A = Cost/Cord (from wood supplier)

B = lbs./Cord (from above table)

C = Cords/Month (from experience, or call Wood Stone for an estimate)

When burned, all wood releases approximately 6500 BTU's/lb. so it is better to compare the price of wood by the pound rather than by the cord. A full cord of wood measures 4' x 4' x 8' when stacked.

$$\text{Cost per lb} = \frac{A}{B}$$

Do Not use pressed wood products in Wood Stone food service equipment, they may damage the ceramics.



ALL WARRANTY SERVICE MUST BE PRE-APPROVED BY WOOD STONE PLEASE CONTACT THE FACTORY FIRST

Please call 1-800-988-8103 or 1-360-650-1111 seven days a week. Our normal business hours are 8am to 4:30pm Pacific Standard time Monday through Friday. If calling during non-business hours, follow the recorded instructions for emergency service and a Wood Stone technician will get back to you promptly. Wood Stone warrants its equipment to the original purchaser against defects in material or manufacture for a period of one year from the original date of purchase subject to the following exclusions and limitations.

EXCLUSIONS

The warranties provided by Wood Stone do not apply in the following instances:

1. In the event that the equipment is improperly installed. Proper installation is the responsibility of the installer; proper installation procedures are prescribed by the Wood Stone installation manual.
2. In the event the equipment is improperly maintained. Proper maintenance is the responsibility of the user; proper maintenance procedures are prescribed in the Wood Stone installation manual.
3. In the event that the failure or malfunction of the appliance or any part thereof is caused by abnormal use or is otherwise not attributable to defect in material or manufacture.
4. In the event that the appliance, by whatever cause, has been materially altered from the condition in which it left the factory.
5. In the event that the rating plate has been removed, altered or obliterated.
6. On parts that would be normally worn or replaced under normal conditions.
7. Normal cracking due to expansion and contraction stress relief in either the dome or oven deck.
- 8. In the event that pressed log products of any type have been burned in the equipment.**
9. Damage resulting from the use of chemical cleaning products in the oven, as well as any damage from liquids or chemicals being poured or sprayed into the oven.

If any oral statements have been made regarding this appliance, such statements do not constitute warranties and are not part of the contract of sale. This Limited Warranty constitutes the complete, final and exclusive statement with regard to warranties.

THIS LIMITED WARRANTY IS EXCLUSIVE AND IN LIEU OF ALL OTHER WARRANTIES WHETHER WRITTEN, ORAL OR IMPLIED, INCLUDING, BUT NOT LIMITED TO, ANY WARRANTY OF MERCHANTABILITY OR FITNESS FOR PARTICULAR PURPOSE OR WARRANTY AGAINST LATENT DEFECTS

LIMITATIONS OF LIABILITY:

In the event of warranty claim or otherwise, the sole obligation of Wood Stone shall be the repair and/or replacement, at the option of Wood Stone, of the appliance or component or part thereof. Such repair or replacement shall be at the expense of Wood Stone with the exception of travel over 100 miles or two hours, overtime, and holiday charges which shall be at the expense of the purchaser. Any repair or replacement under this warranty does not constitute an extension of the original warranty for any period of the appliance or for any component or part thereof. Parts to be replaced under this warranty will be repaired or replaced at the option of Wood Stone with new or functionally operative parts. The liability of Wood Stone on any claim of any kind, including claims based on warranty, expressed or implied, contract, negligence, strict liability or any other theories shall be solely and exclusively the repair or replacement of the product as stated herein, and such liability shall not include, and purchaser specifically renounces any rights to recover, special, incidental, consequential or other damages of any kind whatsoever, including, but not limited to, injuries to persons or damage to property, loss of profits or anticipated profits, or loss of use of the product.

TO SECURE WARRANTY SERVICE:

If you claim a defect covered by this Limited Warranty, direct your claim to:
Wood Stone Corporation 1801 W. Bakerview Rd. Bellingham, WA 98226 USA Attn: National Service Manager