

CLAMPBRO®



SPRAY GUN

MODEL NO: AP8GF

PART NO: 3082130

OPERATION & MAINTENANCE
INSTRUCTIONS



GC0813

INTRODUCTION

Thank you for purchasing this CLARKE Spray Gun.

Before attempting to use this product, please read this manual thoroughly and follow the instructions carefully. In doing so you will ensure the safety of yourself and that of others around you, and you can look forward to your purchase giving you long and satisfactory service.

GUARANTEE

This product is guaranteed against faulty manufacture for a period of 12 months from the date of purchase. Please keep your receipt which will be required as proof of purchase.

This guarantee is invalid if the product is found to have been abused or tampered with in any way, or not used for the purpose for which it was intended.

Faulty goods should be returned to their place of purchase, no product can be returned to us without prior permission.

This guarantee does not effect your statutory rights.

GENERAL SAFETY RULES

Before using this equipment it is in your own interest to read and pay attention to the following safety rules.

1. Keep the work area clean. Cluttered areas invite injuries. Keep work area well lit.
2. Keep children away. Children must never be allowed in the work area.
3. Store idle equipment. When not in use, tools should be locked up in a dry location. Always lock up tools and keep out of reach of children.
4. Use eye protection. Always wear approved safety goggles.
5. Stay alert. Watch what you are doing, use common sense. Do not operate any tool when you are tired.
6. Check for damaged parts. Before using any tool, any part that appears damaged should be carefully checked to determine that it will operate properly and perform its intended function.
7. Do not operate any tool if under the influence of alcohol or drugs. If there is any doubt, do not operate the tool.

COMPRESSED AIR EQUIPMENT

1. Compressed air can be dangerous. Ensure that you are thoroughly familiar with all precautions relating to the use of compressors and a compressed air supply.
2. Never direct a jet of compressed air at people or animals.
3. Always ensure that the equipment being used has a safe working pressure exceeding the output pressure of the compressor that it is connected to.
4. Always ensure that the air supply is turned off at the tool outlet and vent all compressed air from within the air hose and the equipment attached to it, before disconnecting air hoses or other equipment from your compressor.
5. Ensure all fixed airline connections are properly sealed using teflon tape or pipe sealant.
6. Never exceed the operating pressure of 50 psi.

PAINT SPRAYING EQUIPMENT

We strongly recommend that paint spraying equipment be used in conjunction with appropriate eye and face protecting goggles, glasses or spray masks available from most DIY and hardware stores.

1. Always keep the equipment perfectly clean. This will not only prolong its life but will also ensure you get the best results. See Maintenance.

2. Always ensure there is adequate ventilation. Do not spray or handle paint in enclosed areas.
3. Never spray close to any source of heat or flame.
4. Always wear a suitable approved breathing mask when spraying, to protect against inhalation of paint spray or fumes. An air feed mask may be required when spraying some toxic types of paint. If in doubt, check with the paint manufacturer.
5. Always check the manufacturer's data sheets for the paint products being sprayed for any particular hazards and follow the manufacturer's instructions. Take particular care if spraying isocyanate paints. Products used in a spray gun may be covered by COSHH Regulations.
6. Always disconnect the spray gun from the air supply when it is not in use and before any disassembly.
7. Never spray paint towards people or animals.
8. In the case of injury, seek expert medical advice immediately. Never smoke while spraying or preparing paints, or spray near a naked flame, heat source and electrical sparks. Many paints are flammable.
9. Never tamper with the product or modify it in any way, as this could prove to be dangerous and will invalidate the guarantee. Only use the product for the purpose for which it is intended.
10. When replacing parts, only use those supplied by Clarke International as per the parts list.

PRODUCT OVERVIEW

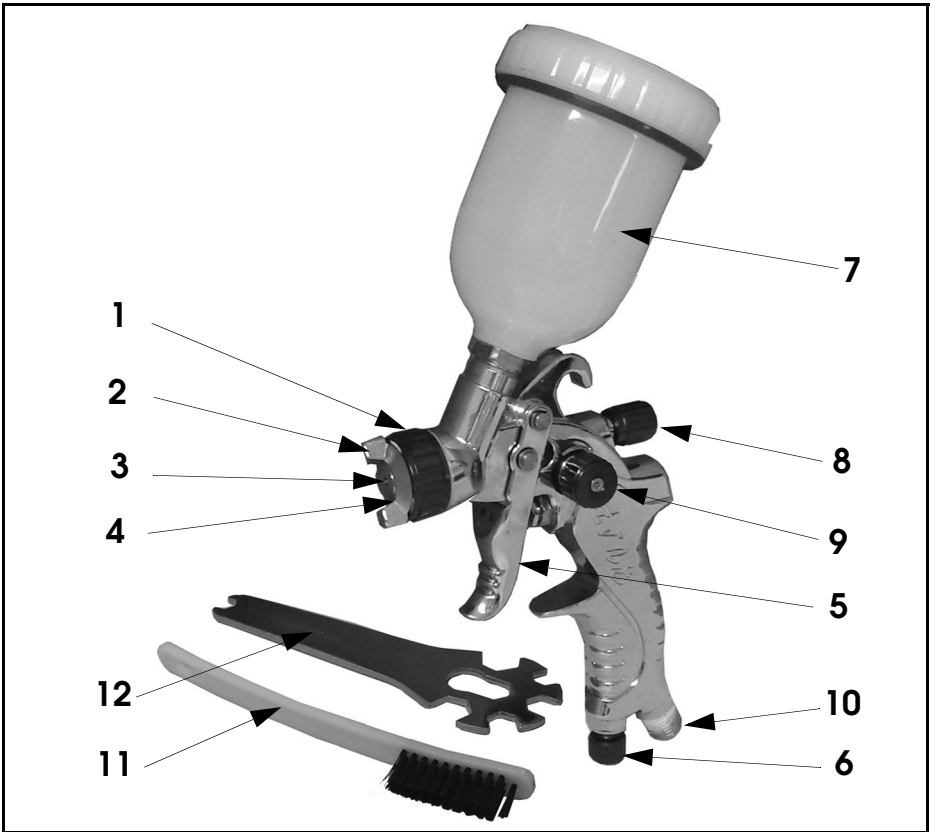

NO	DESCRIPTION
1	Locking Ring
2	Side Wings
3	Air Cap Needle
4	Air Nozzle
5	Trigger
6	Air Regulator Knob

NO	DESCRIPTION
7	Paint Container
8	Fluid Flow Control Knob
9	Spray Pattern Control Knob
10	Airline Connection
11	Cleaning Brush
12	Spanner

SPECIFICATION

Container Volume	100 ml
Air Inlet Connection	1/4" BSP
Minimum Compressor Size	3 HP
Typical Operating Pressure	30-43 psi
Maximum Operating Pressure	50 psi
Paint Delivery	65-100 ml/min
Weight	373 g
Depth x Width x Height	245 x 125 x 65m
Air Consumption	80 l/min
Nozzle Size	0.8 mm

AIR SUPPLY

For best results, the air supply to the spray gun must be clean and dry, with no oil or water contamination. Follow the air compressor manufacturer's guidelines on installation and operation to ensure that your air supply is as clean as possible.

The compressed air supply line to the spray gun must be fitted with a filter capable of removing any oil or water together with a suitable pressure regulator.

Higher pressure and contaminated air will shorten the spray gun life due to faster wear and could become a safety hazard.

Water in the air line will also cause damage and may contaminate the paint being used. Therefore ensure the air supply is properly filtered.

Line pressure, or supply hose inside diameter, should be increased to compensate for unusually long air hoses (over 10 m). Minimum hose diameter should be 6mm (¼") ID, and fittings should have the same inside dimensions.

The air inlet used for connecting air supply has a standard ¼" BSP thread.

OPERATION

The AP8GFM spray gun is fed with paint by gravity from the paint container. The air-flow through the air cap draws paint into the nozzle assembly, where it is atomised and sprayed forward.

The AP8GFM spray gun is supplied with one nozzle size, (0.8 mm). Ensure your spray gun is matched to the capacity of your compressor.

Connect the air supply hose to the air inlet, (using a suitable in-line connector if required).

PREPARATION BEFORE PAINTING

Mix the paint to the correct viscosity for spraying according to the manufacturer's instructions and strain it into the paint container through a fine mesh filter. When mixing the paint, make sure that you have enough thinners left to clean the spray gun after use.

Do not fill the paint container more than 3/4 full. Make sure that the threaded joint between the container and the gun are clean and before screwing the container on the gun. Always clean around the container sealing lip and keep the container vent clear.

Remember that some modern paints require specialist respiratory protection...always consult the paint manufacturers instructions.

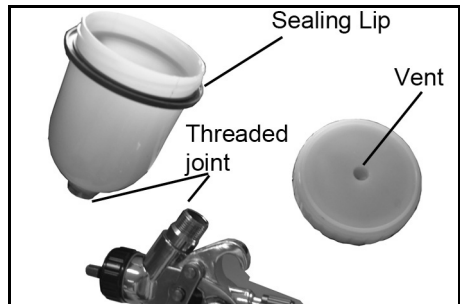

WARNING: NEVER ATTEMPT TO SPRAY UNLESS YOU ARE WEARING SUITABLE, APPROVED RESPIRATORY AND EYE PROTECTION.

Ensure that the area in which you will be spraying is clean and dust free. To obtain best results, it is vital that the surface to be sprayed is well prepared. It must be clean and dry, and free from dust, dirt oil or grease. Mask any area that is not to be sprayed and cover adjacent equipment to protect from overspray.

Check the paint manufacturer's instructions for any special surface preparation required.

REMEMBER - TIME SPENT PREPARING SAVES TIME SPENT FINISHING.

PAINT THINNING

Paint thinning is particularly important when spraying. Many paints are supplied ready for brush application and need to be sufficiently diluted for spraying purposes. Always follow the paint manufacturers instructions. If in doubt, always consult the paint manufacturer.

A Viscosity Cup (not supplied), will assist in determining the correct thickness of the paint.

The ideal viscosity for most paints is as follows:

Water based paints	35-45 secs
Oil based paints	15-25 secs
Enamel paints	15-25 secs
Primers	20-30 secs
Varnishes	20-25 secs
Aluminium paints	15-25 secs
Wood preservatives	Do not dilute
Wood Stains	Do not dilute
Smooth masonry paint	Dilute by 10-15 %

1. Dip the cup into the paint and fill to the brim. Time how long it takes for the cup to empty.
2. Thin as required until times are achieved.
3. Alternatively if a viscosity cup is not available, the following information can be used as a rough guide.
 - Water based paints (emulsions) 10-20% water.
 - Oil based paints (gloss) up to 10% thinners.
 - Cellulose paints up to 50 % cellulose thinners.

If in any doubt, contact the paint manufacturer.

4. Having mixed the paint thoroughly in a separate container, pour into the spray gun paint container through a fine filter.
 - DO NOT OVERFILL PAINT CONTAINER - never more than three quarters full.

ADJUSTMENTS OF THE SPRAY GUN

ADJUSTING THE PAINT FLOW

1. Set the Paint Flow Adjustment knob (8) according to the paint in use and the spray pattern required. (anticlockwise to increase, clockwise to reduce flow).

ADJUSTING THE SPRAY PATTERN

1. Turn the Pattern Adjustment knob (9) anticlockwise to give a fan shaped spray pattern, turning clockwise to give a circular spray pattern.
2. You can adjust the orientation of the fan either vertically or horizontally to suit your requirements by turning the side wings (2) to the desired position.
 - As the width of the spray is increased, paint flow will also need to be increased.

ADJUSTING THE AIR FLOW

1. To increase the air flow, turn the Airflow Adjustment knob anticlockwise to increase and clockwise to decrease the air pressure.
 - The air flow needed will vary according to the paint in use, with thicker paints needing more air.

SPRAYING TECHNIQUES

Practice spraying on a piece of material with the same type of surface as the article you wish to spray, eg. metal for a car body panel, wood for a piece of furniture etc.

Always make adjustments to the spray pattern according to the conditions. You may need to increase the paint and air flow when using a wider fan setting.

To reduce overspray, always use the lowest possible air pressure that produces an acceptable spray pattern.

- If the gun is too far from the surface or the paint is too thin, the paint will start to dry before hitting the surface, resulting in a rough, sandy finish. Allowing overspray to fall on a finished area will also result in a rough finish. Too much paint feed or holding the gun too close to the work will lead to runs and sagging.
- The paint should be agitated by gentle shaking at regular intervals during use to ensure consistency and avoid colour difference due to the paint settling in the container.

To obtain the best results, keep your spray gun level and parallel to the surface at all times. Keep the nozzle 23 - 30 cm from the surface and spray evenly from side to side or up and down. Use your arm to control the spray gun, not your wrist.

The gun should be perpendicular to the surface being covered and moved parallel with it. The stroke should be started before the trigger is pulled and likewise released before the stroke is ended. This gives accurate control of the gun and material.

Do not spray at an angle as this will lead to paint runs on the surface. Always use smooth and even strokes.

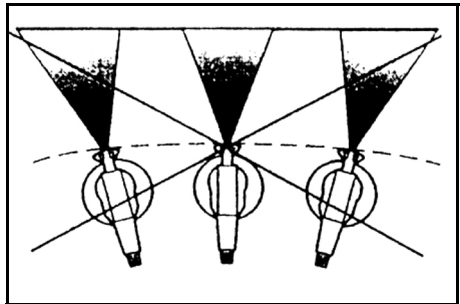
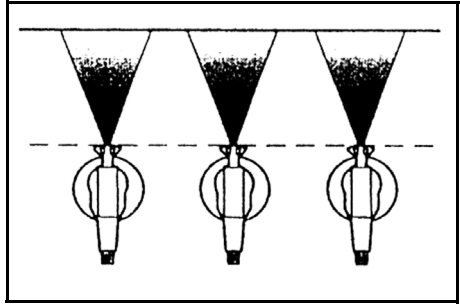

When spraying large areas, using a criss-cross pattern as shown.

Never start or stop the spray gun while it is aimed at the surface to be sprayed. Evenly control the speed of movement of the spray gun.

- Moving quickly over the surface will give a thin coat and slow movement will give a heavy coat.
- Apply one coat at a time. If a further coat is required, make sure you observe the manufacturers drying time recommendations before applying a second coat.
- When spraying small areas, keep the output control on a low setting as this will avoid using too much paint and prevent overspray.
- Where possible, avoid stopping and starting when spraying an object. This can lead to too much, or not enough paint being applied.

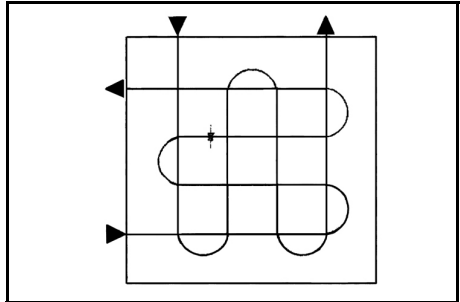

- The material deposited should always be even and wet. Lap each stroke over the preceding stroke to obtain a uniform finish.
- To ensure the edges are covered, start spraying just to the side of the area being sprayed and do not stop until the spray has gone past the opposite edge.
- Damage to the needle or nozzle, or any of the air ports, will result in a faulty spray pattern. Take care when cleaning or assembling these components.

MAINTENANCE

It is essential that the spray gun is kept clean. Dried paint in the nozzle assembly or airways will stop the gun from working. For the gun to perform at its best it must be thoroughly cleaned after every use.

CLEANING PROCEDURE

1. After use, empty any remaining paint from the paint container, wipe the container clean with a dry, lint free rag, and fill with thinner. Spray the thinners through the spray gun until it is clean.
2. Residue from dirty solvent may clog the narrow air passages in the gun. Use a cleaning brush and solvent to wash off accumulated paint.
3. Wipe down the outside of the gun with a solvent dampened cloth.
 - DO NOT poke any of the holes in the air cap or nozzle with metal instruments. These holes are precision drilled and can be damaged by probing with anything harder than a wooden toothpick.
4. Make sure that the air inlet vent to the paint container is kept clean. Blockages in this vent will prevent an even material flow through the gun.
 - Component parts of spray guns are supplied in matched sets and should only be used together.
 - Do not overtighten components, and be careful not to cross thread any parts on assembly.
 - Never use silicon based lubricants as this may cause paint finish defects.
5. Check the air supply hose regularly for any signs of damage and replace it if necessary. Do not use damaged or leaking hoses.
 - Finally, empty the spray gun and dry all components thoroughly. Store in a clean, dry place.

TROUBLESHOOTING

Problem	Cause	Solution
Atomisation is poor (paint comes out in blobs).	Paint volume adjustment is incorrect (paint is too thick).	Add thinners to paint and re-fill. Adjust air regulator to increase pressure.
Over-painting.	Spray gun not clean, resulting in needle valve sticking.	Dismantle spray gun and clean with paint thinners.
	Too much paint.	Adjust the volume regulator to reduce paint volume. Try spraying two thin coats of paint.
	Viscosity too low.	Check the paint viscosity using a viscosity cup.
Orange peel or fogging.	Wrong thinner used.	Use different thinner
	Spray gun held wrong distance from surface.	Hold spray gun at different distance to the surface.
	Paint too thick.	Thin the paint/test viscosity using a viscosity cup.
	Air pressure too high.	Reduce air pressure.
Rough texture as if paint is drying before hitting surface.	Paint is too thin. Air pressure could be too high.	Add more paint to container. Reduce air pressure.

AIRLINE ACCESSORIES AND EQUIPMENT

An extensive range of airline equipment is available from your Clarke dealer including hoses, retractable hose reels, filter/regulators, in-line regulators, pressure gauges, spray gun cleaning kit, respiratory masks and safety goggles.

PARTS DIAGRAM

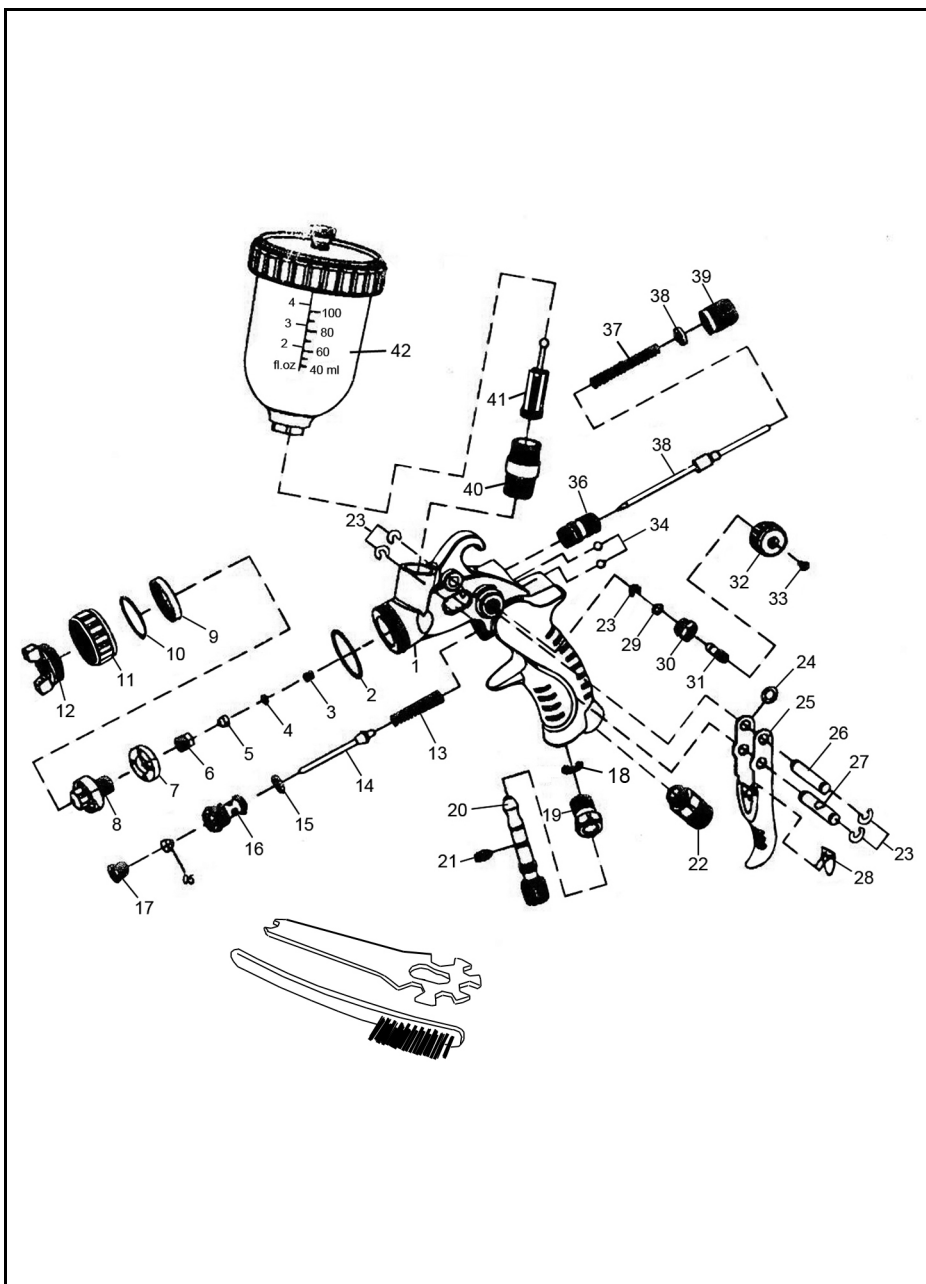

PARTS LIST

ID	DESCRIPTION
1	Gun Body
2	Sealing Gasket
3	Needle Sealing Spring
4	Gasket Needle
5	Needle Sealing Sheath
6	Sealing Screw
7	Airflow Separating Ring
8	Material Nozzle
9	Locknut
10	Sealing Gasket
11	Air Cap
12	Air Nozzle
13	Air Valve Spring
14	Air Valve Stem
15	Sealing Gasket
16	Air Valve Body
17	Sealing Screw
18	Opening Stopper
19	Airflow Adjusting Seat
20	Airflow Adjusting Knob
21	Sealing Ring
22	Air Joint
23	Circlip

ID	DESCRIPTION
24	Trigger Pin Gasket
25	Trigger
26	Trigger Pin
27	Fulcrum Pin
28	Trigger Gasket
29	Sealing Gasket
30	Pattern Adjustment Seat
31	Pattern Adjustment Stem
32	Patern Adjusting Knob
33	Bolt M2.5 x 4
34	Steel Ball 4 mm
35	Needle Adjusting Seat
36	Needle Sub-assembly
37	Needle Adjust Spring
38	Needle Spring Seat
39	Needle Adjusting Knob
40	Paint Passage Connector
41	Trap Valve A
42	Cup Sub-assembly
43	Spanner
44	Cleaning Brush
45	User Manual

DECLARATION OF CONFORMITY



Clarke[®]
INTERNATIONAL

Hemnoll Street, Epping, Essex CM16 4LG

DECLARATION OF CONFORMITY

This is an important document and should be retained.

We hereby declare that this product(s) complies with the following directive(s):

2006/42/EC Machinery Directive.

The following standards have been applied to the product(s):

EN 1953:1998 +A1:2009

The technical documentation required to demonstrate that the product(s) meet(s) the requirement(s) of the aforementioned directive(s) has been compiled and is available for inspection by the relevant enforcement authorities.

The CE mark was first applied in: 2007

Product Description: HVLP Spray gun
Model number(s): AP8GF
Serial / batch Number: N/A
Date of Issue: 05/07/2013

Signed:



J.A. Clarke
Director

A SELECTION FROM THE VAST RANGE OF

Clarke®

QUALITY PRODUCTS

AIR COMPRESSORS

From DIY to industrial, Plus air tools, spray guns and accessories.

GENERATORS

Prime duty or emergency standby for business, home and leisure.

POWER WASHERS

Hot and cold, electric and engine driven - we have what you need

WELDERS

Mig, Arc, Tig and Spot. From DIY to auto/industrial.

METALWORKING

Drills, grinders and saws for DIY and professional use.

WOODWORKING

Saws, sanders, lathes, mortisers and dust extraction.

HYDRAULICS

Cranes, body repair kits, transmission jacks for all types of workshop use.

WATER PUMPS

Submersible, electric and engine driven for DIY, agriculture and industry.

POWER TOOLS

Angle grinders, cordless drill sets, saws and sanders.

STARTERS/CHARGERS

All sizes for car and commercial use.



PARTS & SERVICE: 020 8988 7400

E-mail: Parts@clarkeinternational.com or Service@clarkeinternational.com

SALES: UK 01992 565333 or Export 00 44 (0)1992 565335

Clarke® INTERNATIONAL Hemnall Street, Epping, Essex CM16 4LG
www.clarkeinternational.com