

SAITO™

Saito™ 4-Stroke Gasoline Engines

Owner's Operating Instruction Manual

Model FG-20 & FG-36 | Version 2008



Warning:

- Do not modify any parts of the engine
- This engine is designed for use with radio control model aircraft
- In case of modifications by the customer, Horizon Hobby Inc. shall not bear any responsibility from any damage caused by such modification
- Keep the ignition system well maintained

SAITO

Distributed exclusively by
Horizon Hobby, Inc., Champaign, IL 61822
www.horizonhobby.com

© 2009
SAIMAN1LG

14387
Printed 01/09

Table of Contents

Introduction.....	1
Contents Included	1
Safety Precautions	1
Engine Mounting and Muffler Attachment Notes.....	2
Throttle Linkage.....	3
Propeller	3
Propeller and Fuel Consumption	3
Fuel	4
Fuel Tank and Plumbing	4
Ignition System	4
Spark Plug	5
Carburetor	5
Preparation Before Starting the Engine	6
Starting the Engine	6
Adjustment of the Carburetor	9
General Operating Procedures	10
Normal Operation, Maintenance and Additional Information	10
Troubleshooting Guide	11
Engine Maintenance	11
Valve/Tappet Gap Adjustment	12
Carburetor Maintenance	12
FG-20 Dimensions and Specifications	16
FG-20 Parts List	17
FG-36 Dimensions and Specifications	18
FG-36 Parts List	19
Full Parts List	20
Consumer Warranty and Repair Policy	22

VERY IMPORTANT

Failure to read and follow these instructions before you proceed to start your engine may result in engine damage and the voiding of your warranty.

Introduction

Congratulations on purchasing this fine engine.

It has been over 20 years since Saito introduced their first 4-stroke glow engine, the FA-30. Since that time Saito has led the way in the development of powerful 4-stroke glow engines, from the small FA-30 to the large FA-325 5-cylinder radial engine. Leading the way in innovations, we have seen the V-twins, and now Saito is proud to introduce the 4-stroke gasoline-powered engine.

Saito 4-stroke gasoline engines are developed exclusively for model airplanes. They are designed with an emphasis on high performance, durability and weight savings. Their components are modified to adapt to the gasoline version of existing glow engines and are equipped with a 4-stroke gasoline engine carburetor and ignition systems.

Remember, a properly cared for engine will offer many years of modeling enjoyment.

Features of the Gasoline 4-Stroke Engine

- Fuel efficient
- Fuel cost is low
- Aircraft stays relatively clean during operation

Contents Included

FG-36

Engine
 Engine Mount (SAIG3695)
 Ignition (SAIG36153)
 Muffler (SAIG3674)
 Muffler Manifold (SAIG3675)
 Muffler Nut, 2 pcs (SAIG3680)
 Spark Plug CM-6 (SAIG36120)
 Spark Plug Wrench (SAIG36969)
 Valve Adjusting Tools
 Muffler Wrench
 Instruction Manual
 Saito Decal

FG-20

Engine
 Ignition (SAIG20153)
 Muffler (SAIG2074)
 Muffler Manifold (SAIG2075)
 Muffler Nut, 2 pcs(SAIG2080)
 Spark Plug 1/4-32 (SAIG20120)
 Spark Plug Wrench (FG20967)
 Valve Adjusting Tools
 Instruction Manual
 Saito Decal

Safety Precautions

This manual describes the engine and its general operating procedures. For mounting and control, see the instruction manual for the model airplane. Some suggestions are included in this manual for mounting the engine using the included motor mount.

2 ENGINE MOUNTING AND MUFFLER ATTACHMENT

Note: For proper heat transfer, it is important to use a metal motor mount when mounting these engines in a model aircraft.

- The engine is designed for use on a model radio control airplane. If it is used for any other purpose, we cannot be responsible for its reliability or safety.
- Always use genuine Saito parts for replacements.
- Be sure to check the propeller before each flight. If it is damaged, replace the propeller with a new one.
- If the propeller hits something while the engine is in operation, immediately stop the engine and check for damage.
- Start the engine on a flat surface free of stones or other debris.
- When mixing fuel, or operating the engine, do so in a well-ventilated area.

Engine Mounting and Muffler Attachment Notes

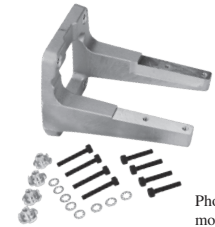

Photo is of the engine mount for the FG-36

Mount the engine on aircraft-grade plywood with more than 6mm thickness

for the FG-20 and 10mm of thickness for the FG-36 or to a mount of equivalent strength, and firmly fixed, with 4 bolts. We highly recommend the use of the Saito Motor Mount (SAIG3695 for the FG-36 or SAIG2095 for the FG-20) to mount this engine to a model aircraft.

Note: Be sure to use flat washers or a metal plate on the reverse side of the mount to prevent the bolts from sinking into the plywood. Before flying the airplane, be sure to check for loose bolts.

Note: Since this engine is equipped with a float less carburetor with a diaphragm pump, the direction of the cylinder and the position of the fuel tank can be upright or inverted.

Figure 1

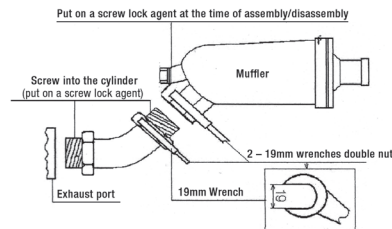

When you attach the muffler, use a drop of oil on the threads to ease the assembly. Screw the exhaust manifold into the engine exhaust port and the

THROTTLE LINKAGE AND PROPELLER 3

muffler as far as the thread will allow (see above drawing). Notice the use of the two wrenches used in tightening the two nuts on the muffler/manifold connection. Use of threadlock is recommended.

Remember to ensure cooling air passes by the engine and muffler in a cowled environment.

Throttle Linkage

Carefully attach the throttle linkage to the engine using a ball link on the carburetor throttle arm. Make sure the linkage is free to operate from low throttle to high throttle. Also, confirm that the low throttle setting on the transmitter closes the carburetor throttle barrel to the low idle position. Adjust the length of the pushrod until full throttle opens the carburetor throttle barrel to the fully open position, while low throttle, low trim completely closes the throttle barrel.

Propeller

Recommended Propeller Sizes:
The recommended propeller sizes are shown in the table below. The use of a carbon fiber propeller is highly recommended. Remember that the use of a large propeller will require care in balancing it. Vibration will reduce performance and can result in damage to the engine and airframe.

For break-in, Saito recommends the use of a smaller propeller for initial break-in and approximately 20 subsequent flights.

Diameter x Pitch (inches)

FG-20	FG-36
15 x 6-10"	17 x 10-13"
16 x 6-8"	18 x 8-10"
17 x 6"	19 x 8-10"
3 blade 15x7-9"	20 x 8"

The engine produces the maximum output when the engine is running at about 8,300–9,000 rpm. We would recommend using a propeller which makes the engine run at approximately 7,000–9,500 rpm while the airplane is in flight.

Propeller and Fuel Consumption

In order to decrease fuel consumption and prolong the life of the engine, a propeller should be selected that maximizes rpm's when the throttle is fully open, and an airframe that will perform flights at about 90% of the propeller output. If the load is large, (the diameter and pitch of the propeller is large) the air-fuel mixture will have to be rich. If the load is small, the rpm's will be high, but the fuel consumption is lowered because the high-speed needle valve is closed or leaned out more.

Fuel

- Mix a ratio of gasoline to oil of 20:1 for break-in and continuous operation on all engines.
- A mixture of commercial regular gasoline and a reliable High quality 100% Synthetic oil for 2-cycle engines must be used (we recommend Evolution Oil, EVOX1001Q). Unleaded high-octane gasoline is not required for Saito engines.
- Remember to use caution in the storage, use and transport of gasoline.
- Since commercial gasoline has many impurities, please be sure to use a reliable fuel filter (SAI50109) in your fuel system.

Note:

- Be sure to use a gasoline-resistant type of fuel tubing (like Tygon). DO NOT use any silicone rubber type of fuel line to the engine or in the fuel tank.
- The use of fuel with up to 10% ethanol has been tested and found to work fine.

Figure 2

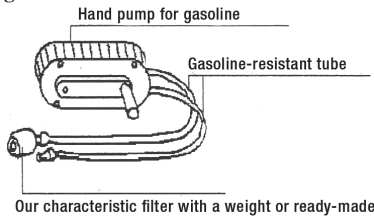

Fuel Tank and Plumbing

Figure 3

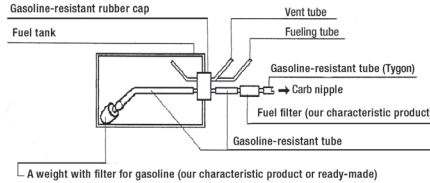

Be sure to include a reliable fuel filter in your fuel system. The drawing above suggests use of a fuel feed line and an air intake line. Also, be sure to use a fuel line compatible with gasoline.

IMPORTANT: Air is necessary to cool the engine during operation. Make sure that sufficient air circulation through the cowling is provided. As a basic reference, the outlet area should be 3 to 5 times the area of the inlet area to provide adequate cooling.

Ignition System

Saito gasoline four-stroke engines come with Saito's own ignition system composed of the ignition unit, cord for sensor (black and white), cord for earth to ground (green) insulated plug cap, and cord (black and red) for connection to a battery (not included). You will also need to secure an on/off switch (safety switch system). The switch must be

capacity of more than 1,000mA. Be sure to mount the ignition system in a location near the engine and away from

the receiver to prevent any unwanted interference. Please refer to the diagram below.

Figure 4

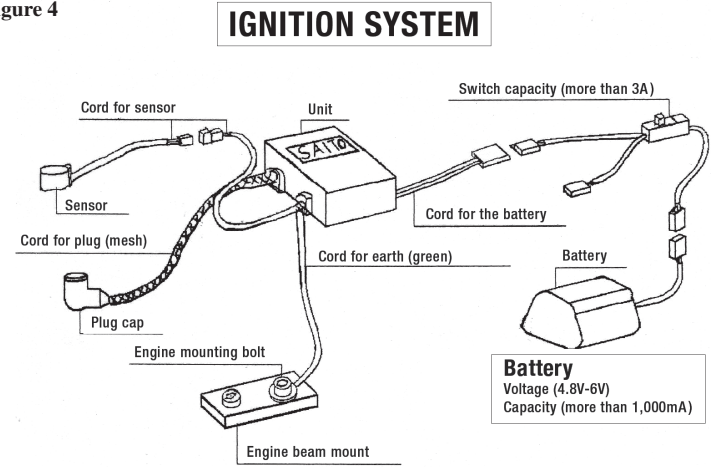

Spark Plug

NGK-CM6
 Spark gap = .7-.8mm (.024 - .028 in)
1/4-32
 Spark gap = .4 - .5mm (.016 - .020 in)

NGK-CM6 (SAIG36120) is the standard-equipped plug with the FG-36. The FG-20 comes with Saito's own 1/4-32 spark plug (SAIG20120). When needed, please replace with identical appropriate plugs.

Carburetor

The carburetor used on gasoline four-stroke engines are exclusive to Saito. Since they have a negative pressure type fuel pump, the engine can be mounted in any position.

CAUTION: If fuel remains in the carburetor after flight, the components made from rubber, such as the diaphragm, will deteriorate over time.

After a flying session, it is best to remove any fuel remaining in the carburetor by disconnecting the fuel line and

rated to a minimum 3A.

Saito recommends the use of a battery with a voltage of 4.8V to 6V and running the engine until it is dry.

Do not needlessly disassemble the carburetor. If you experience problems with the carburetor, return it to the Saito Horizon Service Center.

Preparation Before Starting the Engine

(prior to break-in)

- Mount the engine on a strong, flat test bench or on the aircraft. (In either case, the engine should be secured so it is immobile.)
- Check to make sure the throttle barrel will open and close completely.
- Check the wiring of the ignition system to make sure it is connected correctly and securely.
- Make sure the fuel line is connected securely to the carburetor.
- For break-in, use a fuel/oil mix ratio of 20:1.
- FG-36: Mount an 18x8 or 19x8 carbon fiber propeller such as a Bolly or Mejzlik. Be sure it has been balanced. (Remember to check the tightness after every flight.)
- FG-20: Mount a 15x6 plastic or wood propeller. Be sure it has been balanced. (Remember to check the tightness after every flight.)

- It is suggested you employ a spinner when using an electric starter. (Remember to check the tightness after every flight.)
- Use a tachometer to prevent over-revving of the engine.
- Be sure to connect a gasoline-proof line to the breather nipple to vent oil from the airframe.
- Check the battery of the electric starter to make sure it is fully charged. Be sure to use a safety on/off switch from the battery to the ignition.

WARNING: Do not let people stand in front of or to the side of the engine while attempting to start it. Also, make sure the engine test bench or aircraft is completely secure from movement.

Starting the Engine

(assuming the engine is mounted in an aircraft)

Saito's carburetors come adjusted to a basic setting. This setting should be maintained during the initial break-in runs. The standard carburetor settings are as follows: The high-speed needle valve is set to about 2 1/3 turns from the fully closed position. The low speed or idle needle valve is set to about 4 turns out from the fully closed position. Please refer to the diagrams on the next page.

Before you first start the engine, make

IMPORTANT: Never turn the engine over with the ignition turned on unless the spark plug is inserted in the plug socket. This could lead to ignition damage.

Note: Saito 4-stroke gasoline engines come with a pumped carburetor. You do not have to choke the engine as you normally would a 2-stroke engine.

When you are ready to start the engine, switch the ignition on and set the throttle to a slightly high idle speed. We highly recommend the use of an electric starter.

Be sure to have a helper hold the model securely.

- Turn on the transmitter first, then the receiver and check the operation of the throttle servo and other controls.
- Turn on power to the ignition system.
- Using an electric starter, begin cranking the engine. It should fire within seconds of applying the starter. Allow the engine to idle for 30 to 45 seconds.
- If the engine does not start, even after using the electric starter to crank the engine a second time, open the throttle to maximum, turn off the ignition and turn the engine over about 4 revolutions. Switch the ignition on again and then restart the engine with the throttle at a fast idle position.
- If the engine still will not start, unscrew the spark plug and check its

Figure 5

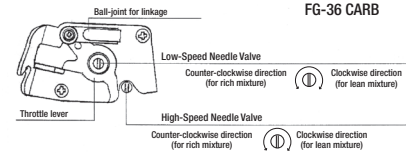
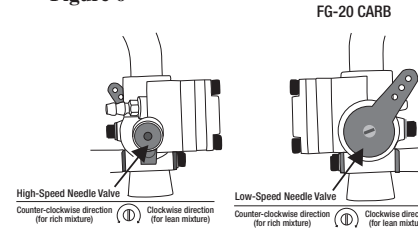

Figure 6



sure that the spark plug is screwed in and tightened, and that the plug socket cap is fitted in place and fastened down properly. Fix the ignition sensor in the proper position at the bottom of the engine crankcase. The throttle servo should be mounted at a distance of 8 to 12 inches from the engine. The spark plug cable must not touch any part of the model structure as vibration may damage the shielded cable. If this is not practical, it will be necessary to provide an insulation material for the cable. The ignition unit itself should be wrapped in foam rubber to prevent engine vibration from damaging the electronic components. All components must be protected from contact with engine fuel. Be sure to use an on/off (Safety or "kill") switch to allow the ignition to be turned off and on.

contacts. Clean any possible excess fuel (an indication of engine flooding) and screw it in again. Further starting should only be done with the throttle at idle position. If the plug is dry, probably not enough fuel has been drawn into the carburetor. If that is the case, check the fuel feed and then return to the instructions in paragraph A.

Note: We strongly urge the use of a tachometer to check rpm readings when breaking in the engine.

After starting and warming the engine for 30 to 45 seconds adjust as follows: For initial break-in: do not exceed 4,000 rpm for the first 10 minutes of operation. This allows all the parts to mate properly with good lubrication.

Step I. Move the throttle to 2/3 high throttle position quickly (fast acceleration). Repeat three times. If the engine accelerates smoothly go to Step III. If acceleration is not smooth, go to Step II.

Step II. Faulty acceleration and a tendency to quit is usually attributable to a poor fuel mixture in the medium rpm range. Stop the engine and recheck the fuel feed. The fuel line must not be pinched or broken. Restart the engine and test acceleration again. If the problem persists adjust the carburetor. Open the low-speed needle by 5 minutes and retest. If acceleration is smooth,

open the needle by another 3 to 5 minutes. This should be done because the needle was previously set too lean. If the engine continues to not accelerate properly, open the low-speed needle by 10 minutes. If the engine's operation does not improve, shut it off and check the basic setting, restart the engine and test the acceleration. If the engine continues to not accelerate properly, the defect is likely to lie somewhere other than an adjustment. If the engine runs correctly, go to Step III.

Step III. If the engine accelerates correctly, set it at idle speed and accelerate to full speed. Repeat twice more. If the engine functions correctly, go to Step IV. If it cuts out, open the low-speed needle valve by 5 to 10 minutes more. If the engine does not respond to acceleration fast enough, keep closing the low-speed needle until the engine starts to cut out in response to throttle opening. At that point, re-open the low-speed needle by 5 to 10 minutes.

Step IV. If the engine reacts correctly, set it at full speed. If the revolutions do not drop, the engine has been adjusted successfully. If the revolutions seem to drop, open the high-speed needle by about 5 to 10 minutes.

CAUTION: The engine must be stopped while you adjust the carburetor in order to prevent injury by the propeller. Subsequent runs may be made

while slightly leaning out the mixture with each tank full of fuel. Forty minutes is considered sufficient time for normal break-in prior to the first flight.

The use of a tachometer is encouraged for setting the high-speed needle valve prior to flight. The peak rpm should be obtained and then reduced by 200 to 300 rpm. Over-revving of a 4-stroke engine can cause internal damage to the engine.

Adjustment of the Carburetor

The low-speed needle valve is set at the factory so that idle rpm may be between 1,800 and 2,100 rpm.

In principle, a carburetor is adjusted by first achieving highest rpm with the high-speed needle valve and then performing idling (low speed rpms) with the throttle valve and the low-speed needle valve. (Unless peak rpm is achieved, idling adjustment will be difficult to adjust and will not be stable.)

- After filling the tank, start the engine and move the throttle to the fully open position.
- Turn the main needle valve screw clockwise (refer to Figure 5, page 7) with the carburetor adjustment bar (provided in the accessories package) or a small screw driver, and adjust to achieve peak rpm. Use a tachometer to verify rpm.

CAUTION: Over-closing the main

needle valve is very dangerous because it may cause knocking and preignition. It may also cause the propeller nut to loosen. Immediately turn the main needle counterclockwise to richen up the setting.

- Next, close the throttle valve until the engine operates stably and with an idle rpm of around 1,700 rpm. Do this by adjusting the low-speed needle valve with the carburetor adjustment bar (or small screwdriver) and manipulating the throttle valve via the throttle stick on the transmitter.
- After reaching the stable 1,700 rpm, slowly open the throttle fully. If the rpms become slow or go up suddenly, adjust carefully until the changes are smooth from idle to peak rpm, by adjusting the low-speed needle valve.
- After the previous steps have been accomplished, repeat the process from idle to high rpm quickly. If the rpms do not reach peak, but stutter as the throttle moves from low to high, re-tune the main needle valve and perform the process from idling to peak quickly.
- Repeat the process until the response is a smooth transition from idle to peak rpm.

Factory settings for the main and low-speed needle valves are as follows.

- Main needle valve: Turn needle valve all the way clockwise and then back

- out 2 1/3 turns.
- Idle needle valve: With the throttle barrel closed, turn the needle valve all the way clockwise and then back out 4 turns.
- Set the throttle barrel at the fully closed position before making any adjustments.

General Operating Procedures

(to ensure the long life of the engine)

- Do not operate the engine with a “lean” mixture.
- Regularly check all screws and nuts on both the engine and muffler.
- After 1 to 2 hours of operation, valve adjustment may be necessary. Adjust the valves as shown in the Engine Maintenance and Valve/Tappet Adjustment Sections.
- The Saito engines are equipped with a “breather” nipple. It is recommended that a length of Tygon-type tubing be attached to this crankcase breather nipple and routed away from the engine compartment so the excess oil can be expelled outside of the aircraft.

Normal Operation, Maintenance and Additional Information

- Be sure to do a range check before flying your model. It would be wise to do the range check with the engine

running and without it running. As a simple noise check, after the engine is started, do the normal range check your radio manufacturer recommends. If there is no malfunction noted, it is normal.

- Be sure to charge the ignition battery and radio system battery before the first flight of the day.
- To discharge the waste oil, connect a gasoline-proof line from the breather nipple on the crankcase and vent it outside of the aircraft.
- Lubrication of the piston, connecting rod, bearings and cam gear is blow-by lubrication, in which the oil in the fuel goes into the crankcase from the clearance between the cylinder and the piston. Engine life is directly affected by the property of the fuel/oil mix. Please use reliable oil.
- Running the engine too lean causes heat; be sure to run the engine slightly “rich” from peak. Running too lean will cause “knocking” or engine failure and has an adverse effect on the connecting rod and the cam gear.
- Adjustment of the tappet is described in the “Valve/Tappet Gap Adjustment” section.
- When attaching an exhaust pipe to the cylinder or attaching a propeller nut, the use of threadlock is recommended.
- Sometimes it is helpful to tighten an

- please refer to the following steps.
- Cylinder screws should be loosened in a crisscross pattern.
 - Assemble the cam gear lining up the timing mark at the “6 o’clock” position. The crankshaft must be positioned at the “12 o’clock” or “top dead center” (TDC) position. Refer to figure below:

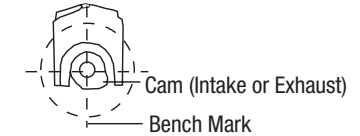

- Reassemble the piston, rod, rocker arm, pins, pushrod, tappet, etc. in their original positions. Engine parts are mated after running the engine and must be reassembled as close as possible to their original position.
- Assemble the engine, reversing the crisscross pattern used in the disassembly. Prior to tightening each of the screws, apply a drop of oil to prevent thread damage.
- Normal engine maintenance, such as adjusting the valves or carburetor, is permissible without voiding the warranty. If you have any questions concerning maintenance procedures, please contact the Saito Horizon Service Center at 877-504-0233. Our technicians will be happy to advise you on maintenance issues.

- exhaust nut, etc. when hot.
- When finished flying for the day, be sure to remove fuel from the carburetor and the fuel tank.
- If the engine will not be operated for a long period of time, remove the plug, rear cover, cylinder-head cover, etc. clean thoroughly and re-oil. Then assemble them in the original condition and place in a plastic or airtight container.

Troubleshooting Guide

If the engine does not start:

- Check and use a new spark plug if needed.
- Check fuel lines.
- Check for proper mechanical function by turning the engine over.
- Check that the carburetor is correctly installed.

Mechanical Faults

If the engine cannot be turned over easily:

- It is likely that the piston in the cylinder is seized.
- Visually examine the piston and crankcase to find the likely cause of the engine's mechanical problem.

Engine Maintenance

Do not needlessly disassemble your Saito single-cylinder engine.

If you must disassemble your engine,

Valve/Tappet Gap Adjustment

After approximately one hour of operation, tappet gap adjustment may be necessary. When you check the valves, lubricate the moveable parts. Also make sure the screw is in tight before making adjustments to valves.

Adjust the valves to a clearance of .03mm to .10mm (.002 to .004 in) using the supplied gauge. The valves must be adjusted with the engine cold due to thermal expansion.

Note: Valves must be in the compression stroke or closed position as shown in the following figure. When adjustment is completed, make sure you tighten the lock nut.

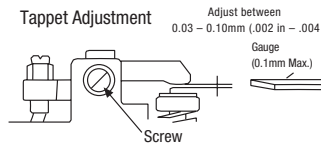

How to Adjust

Remove the plug and the rocker arm cover and revolve the propeller slowly clockwise by hand. The intake side rocker arm stops, and by turning it, the piston reaches the compression top dead center (TDC).

In that position, adjust with the included gauge and hexagonal wrench so tappet gap may be set to almost zero when the engine is in the compression stroke. If the gauge can enter (a limit gauge with a 0.1 mm thickness), the clearance is at

maximum and needs adjustment, adjust between 0.03 and 0.10mm (0.002 to 0.004 in.) After the gap is checked, tighten the locknut securely. Do not over-tighten.

The tappet gap is the most important factor in the maintenance of 4-stroke engines, and operation with an excess clearance will degrade performance. In particular, a large gap aggravates abrasion of the tappet and the cam and also increases the unusual sound.

Carburetor Maintenance

Should you experience difficulty with the carburetor of your engine:

- Factory settings for the idle needle valve are about 4 turns out from a fully closed position.
- The high-speed needle valve is set to about 2 1/3 turns out from a fully closed position and is a good point to start from.

Generally speaking, there are very few things that will keep today's modern gasoline engines from starting. To that end, make sure you are using good-quality "fresh" fuel, the spark plug is good, and the ignition system is working properly.

Check the battery voltage to make sure the ignition is getting the proper voltage. Should the engine fail to start after these items are verified, refer to the Troubleshooting Guide on page 11.

OUTSIDE DIMENSIONS (mm)

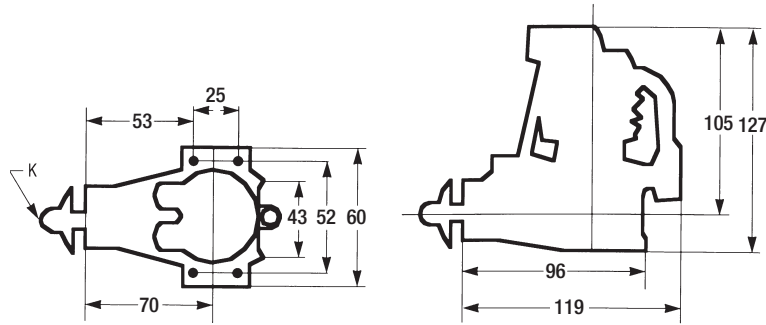

SPECIFICATIONS

Disp: 20.52cc (1.25 cu in)
 Bore: 31.7mm (1.24 in)
 Stroke: 26mm (1.02 in)
 Weight: (Engine only); 21.9 oz (620 g)
 Weight: (Muffler only): 2.9 oz (80 g)
 Weight: (Ignition only); 5.2 oz (146 g)
 Total weight with muffler and ignition system: 30.1 oz (850 g)
 Crankshaft: M8x1.25
 Cylinder: AAC
 Fuel Efficiency: 15cc/minute
 Propeller Size: Dia. 15-16 x Pitch 6-8, Dia. 17 x Pitch 6

Benchmark Propeller: APC 16x8W @ 8,700 rpm
 RPM Range: 1,700–10,000 rpm
 Fuel consumption will depend on the load of the propeller. During actual flight, fuel consumption increases slightly.
 Electrical usage of ignition system: Approximately 200mAh for 15 minutes.
 Fuel: Gasoline-Oil mix of 20:1 (20:1 is recommended for break in and continuous operation).
 Oil: The use of only 100% synthetic oil is such as our Evolution Oil (EVOX1001Q)

SAITO FG-20 PARTS LIST

#	DESCRIPTION	QTY	#	DESCRIPTION	QTY
01	Cylinder (left)	1	42	Rocker arm screw and nut (42-1,42-2)	2ea
06	Piston	1	43	Rocker arm pin	2
07	Piston pin	1	44	Rocker arm bracket (left)	1
08	Piston pin retainer	2	45	Rocker arm bracket (right)	1
09	Piston ring	1	46	Valve (in and out) (46-1, 46-2)	2
10	Connecting rod	1	47	Valve spring+Keeper+Retainer (47-1,47-2,48)	2ea
14	Cylinder screw set (14-1, 14-2, 14-3, 14-4)	1set	48	Valve retainer (Cotter)	4
15	Crankcase	1	49	Rocker arm cover	2
17	Rear cover	1	69	Intake manifold	1
19	Breather nipple	1	74	Muffler	1
20A	Front bearing	1	75	Muffler manifold (75-1, 80)	1
22	Rear bearing	1	80	Muffler nut	2
23	Crankshaft	1	82-1	Carburetor complete	1set
27A	Taper collet and drive flange (27-1, 27-2)	1ea		Carburetor body assembly	1set
28	Prop washer and nut (28-1,28-2)	1ea	83-1	82-1-1, 82-1-2, 82-1-3, 82-1-4, 82-1-5	
31	Crankcase screw set (31-1, 31-2, 31-3)	1set		Carburetor screw and spring set	
32	Engine gasket set (32-1, 32-2, 32-3, 32-4)	1set	90	82-1-9, 82-1-10, 82-1-11, 82-1-12	1set
33	Cam gear housing	1	91	Carburetor gasket set (82-1-6, 82-1-7, 82-1-8)	1set
35	Cam gear	1	93	Intake velocity stack	1
36A	Cam gear shaft	1	95	Engine mount set (95-1, 95-2, 95-3, 95-4, 95-5)	1set
37	Steel and washer set (37-1, 37-2)	1set	110	Anti loosening nut	1
38	Tappet	2	149	Oil slinger	1
39	Pushrod	2	152	Screw-pin (for drive flange setting)	1
40	Pushrod cover and rubber seal (40-1, 40-2, 40-3)	2ea	153	Electronic ignition system	
41	Rocker arm	2		153-1, 153-2, 153-3, 153-4	1set

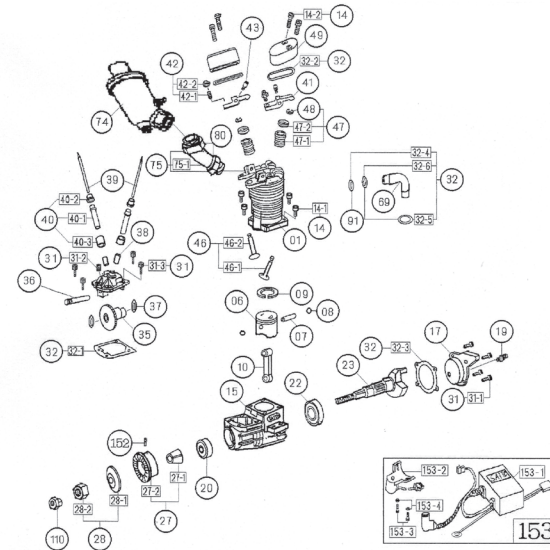

OUTSIDE DIMENSIONS (mm)

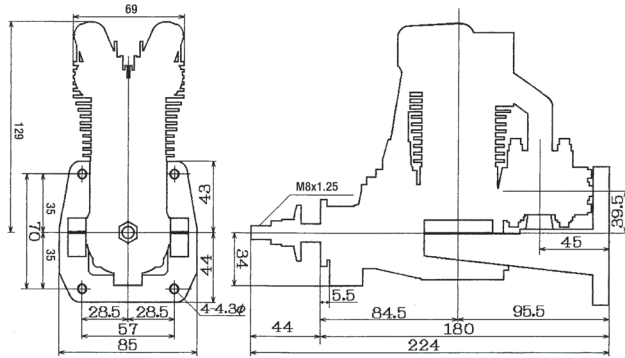

SPECIFICATIONS

Disp: 36.3cc (2.20 cu in)
 Bore: 38mm (1.49 in)
 Stroke: 32mm (1.26 in)
 Weight: (Engine only) 48.2 oz (1252 g)
 Weight: (Muffler only) 3.0 oz (86 g)
 Weight: (Engine Mount only) 9.6 oz (270 g)
 Weight: (Ignition only) 5.4 oz (152 g)
 Total weight with motor mount, muffler and ignition system: 66.2 oz (1760 g)
 Crankshaft: M8x1.25
 Cylinder: AAC
 HP: 3.5 approximately
 Fuel Efficiency: 30cc/minute
 Propeller Size: Dia. 18–19 x Pitch 8–9; Dia. 20x Pitch 8

Benchmark Propeller: APC 18x6W @ 8,300 rpm
 RPM Range: 1,700–9,000 rpm
 Fuel Consumption: Approximately 30cc/minute at full throttle and approximately 7,500 rpm. Fuel consumption will depend on the load of the propeller. During actual flight, fuel consumption increases slightly.
 Electrical usage of ignition system: Approximately 200mAh for 15 minutes.
 Fuel: Gasoline-Oil mix of 20:1 (20:1 is recommended for break in and continuous operation).
 Oil: The use of only 100% synthetic oil is such as our Evolution Oil (EVOX1001Q)

SAITO FG-36 PARTS LIST

#	DESCRIPTION	QTY	#	DESCRIPTION	QTY
01	Cylinder (left)	1	42	Rocker arm screw and nut (42-1,42-2)	2ea
06	Piston	1	43	Rocker arm pin	2
07	Piston pin	1	44	Rocker arm bracket (left)	1
08	Piston pin retainer	2	45	Rocker arm bracket (right)	1
09	Piston ring	1	46	Valve (in and out) (46-1, 46-2)	2
10	Connecting rod	1	47	Valve spring+Keeper+Retainer (47-1,47-2,48)	2ea
14	Cylinder screw set (14-1, 14-2, 14-3, 14-4)	1set	48	Valve retainer (Cotter)	4
15	Crankcase	1	49	Rocker arm cover	2
17	Rear cover	1	69	Intake manifold	1
19	Breather nipple	1	74	Muffler	1
20A	Front bearing	1	75	Muffler manifold (75-1, 80)	1
22	Rear bearing	1	80	Muffler nut	2
23	Crankshaft	1	82-1	Carburetor complete	1set
27A	Taper collet and drive flange (27-1, 27-2)	1ea		Carburetor body assembly	1set
28	Prop washer and nut (28-1, 28-2)	1ea	83-1	82-1-1, 82-1-2, 82-1-3, 82-1-4, 82-1-5	1set
31	Crankcase screw set (31-1, 31-2, 31-3)	1set		Carburetor screw and spring set	1set
32	Engine gasket set (32-1, 32-2, 32-3, 32-4)	1set	90	82-1-9, 82-1-10, 82-1-11, 82-1-12	1set
33	Cam gear housing	1	91	Carburetor gasket set (82-1-6, 82-1-7, 82-1-8)	1set
35	Cam gear	1	93	Intake velocity stack	1
36A	Cam gear shaft	1	95	Engine mount set (95-1, 95-2, 95-3, 95-4, 95-5)	1set
37	Steel and washer set (37-1, 37-2)	1set	110	Anti loosening nut	1
38	Tappet	2	149	Oil slinger	1
39	Pushrod	2	152	Screw-pin (for drive flange setting)	1
40	Pushrod cover and rubber seal (40-1, 40-2, 40-3)	2ea	153	Electronic ignition system	1set
41	Rocker arm	2		153-1, 153-2, 153-3, 153-4	

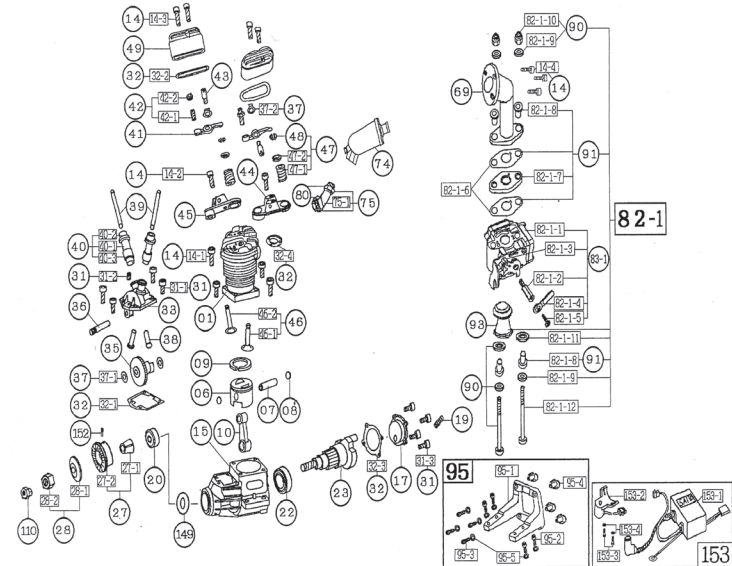

20 PARTS LIST

	FG-20	FG-36
01 Cylinder, Left	G2001	G3601
06 Piston	125A06	220a06
07 Piston Pin	120S07	220A07
08 Piston Pin Retainer (6 Pc)	120S08	120S08
09 Piston Ring	125A09	220A09
10 Connecting Rod	125A10	G3610
14 Cylinder Screw Set	6514	220A14
15 Crankcase	G2015	G3615
17 Rear Cover	G2017	220A17
19 Breather Nipple	6519	6519
20 Front Ball Bearing	120S20A	120S20A
22 Rear Ball Bearing	120S22	120S22
23 Crankshaft	G2023	G3623
27 Tapered Collet & Drive Flange	G2027	G3627
28 Prop Washer & Nut	125A28	170R3135
29 Prop Nut, Spinnet	120S29	120S29
30 Prop Nut, Electric Starter	120S30	120S30
31 Crankcase Screw Set	5031	5031
32 Engine Gasket Set	G2032	--
33 Cam Gear Housing	170R333	300T33
35 Cam Gear, Right	6535A	120S35
36 Cam Gear Shaft	170R336A	5036A
37 Teflon/Steel Washer Set	125A37	120S37
38 Tappet (2Pc)	5038	120S38
39 Pushrod (2Pc)	90TS39	220A39
40 Pushrod Cover & Rubber Seal	325R540	220A40
41 Rocker Arm (Pr)	5041	120S41
42 Rocker Arm Screw and Nut (2 Sets)	5042	300T42
43 Rocker Arm Pin (2Pc)	5043	120S43
44 Rocker Arm Bracket, Left	--	120S44
45 Rocker Arm Bracket, Right	--	120S45
46 Valve-In/Out (Pr)	125A46	G3646
47 Valve Spring, Keeper, Retainer (2 Sets)	6547	120S47
48 Valve Retainer (4Pc)	5048	120S48
49 Rocker Arm Cover (Pr)	5049A	150S49
69 Intake Manifold, Left	G2069	G3669
74 Muffler, Right	G2074	G3674
75 Muffler Manifold, Standard	125A75	--
80 Muffler Nut (2Pc)	125A80	220A80
82-1 Carburetor-Complete, Left	G20821	G36821
83-1 Carburetor Body Assembly, Left	G20831	G36831
85 High-Speed Needle Valve	10085	--
86 High-Speed Needle Valve Extension	5086	--
87 Throttle Barrel Assembly	G2087	--
88 Throttle Lever	5088B	--

PARTS LIST 21

	FG-20	FG-36
89 Idle Needle Valve	G2089	--
90 Carburetor Screw & Spring Set	G2090	G3690
91 Carburetor Gasket Set	G2091	G3691
93 Intake Velocity Stack	--	G3693
95 Engine Mount	G2095	G3695
96 Tool Set	G2096	G3696
97 Instruction Manual	MAN1G	MAN1G
109 F-1 Fuel Filter	50109	50109
110 Anti-Loosening Nut	56110	170R3110
111 Flexible Exhaust Pipe	125A111	--
117 M4 Nut for Spinner	120S117	120S117
118 M5 Nut for Spinner	120S118	120S118
120 Spark Plug	G20120	G36120
135 Prop Washer/Nut/Anti-loosening Nut	125A135	170R3135
152 Screw-Pin	G36152	G36152
153 Electronic Ignition System	G20153	G36153
160 Pump Assembly	G20160	--

Consumer Warranty and Repair Policy

Warranty Period:

Exclusive Warranty- Horizon Hobby, Inc., (Horizon) warranties that the Products purchased (the "Product") will be free from defects in materials and workmanship for a period of 3 years from the date of purchase by the Purchaser.

Limited Warranty

(a) This warranty is limited to the original Purchaser ("Purchaser") and is not transferable. REPAIR OR REPLACEMENT AS PROVIDED UNDER THIS WARRANTY IS THE EXCLUSIVE REMEDY OF THE PURCHASER. This warranty covers only those Products purchased from an authorized Horizon dealer. Third party transactions are not covered by this warranty. Proof of purchase is required for warranty claims. Further, Horizon reserves the right to change or modify this warranty without notice and disclaims all other warranties, express or implied.

(b) Limitations- HORIZON MAKES NO WARRANTY OR REPRESENTATION, EXPRESS OR IMPLIED, ABOUT NON-INFRINGEMENT, MERCHANTABILITY OR FITNESS FOR A PARTICULAR PURPOSE OF THE PRODUCT. THE PURCHASER ACKNOWLEDGES THAT THEY ALONE HAVE DETERMINED THAT THE PRODUCT WILL SUITABLY MEET THE REQUIREMENTS OF THE PURCHASER'S INTENDED USE.

(c) Purchaser Remedy- Horizon's sole obligation hereunder shall be that Horizon will, at its option, (i) repair or (ii) replace, any Product determined by Horizon to be defective. In the event of a defect, these are the Purchaser's exclusive remedies. Horizon reserves the right to inspect any and all equipment involved in a warranty claim. Repair or replacement decisions are at the sole discretion of Horizon. This warranty does not cover cosmetic damage or damage due to acts of God, accident, misuse, abuse, negligence, commercial use, or modification of or to any part of the Product. This warranty does not cover damage due to improper installation, operation, maintenance, or attempted

repair by anyone other than Horizon. Return of any goods by Purchaser must be approved in writing by Horizon before shipment.

Damage Limits:

HORIZON SHALL NOT BE LIABLE FOR SPECIAL, INDIRECT OR CONSEQUENTIAL DAMAGES, LOSS OF PROFITS OR PRODUCTION OR COMMERCIAL LOSS IN ANY WAY CONNECTED WITH THE PRODUCT, WHETHER SUCH CLAIM IS BASED IN CONTRACT, WARRANTY, NEGLIGENCE, OR STRICT LIABILITY. Further, in no event shall the liability of Horizon exceed the individual price of the Product on which liability is asserted. As Horizon has no control over use, setup, final assembly, modification or misuse, no liability shall be assumed nor accepted for any resulting damage or injury. By the act of use, setup or assembly, the user accepts all resulting liability.

If you as the Purchaser or user are not prepared to accept the liability associated with the use of this Product, you are advised to return this Product immediately in new and unused condition to the place of purchase.

Law: These Terms are governed by Illinois law (without regard to conflict of law principals).

Safety Precautions:

This is a sophisticated hobby Product and not a toy. It must be operated with caution and common sense and requires some basic mechanical ability. Failure to operate this Product in a safe and responsible manner could result in injury or damage to the Product or other property. This Product is not intended for use by children without direct adult supervision. The Product manual contains instructions for safety, operation and maintenance. It is essential to read and follow all the instructions and warnings in the manual, prior to assembly, setup or use, in order to operate correctly and avoid damage or injury.

Questions, Assistance, and Repairs:

Your local hobby store and/or place of purchase cannot provide warranty support or repair. Once

assembly, setup or use of the Product has been started, you must contact Horizon directly. This will enable Horizon to better answer your questions and service you in the event that you may need any assistance. For questions or assistance, please direct your email to productsupport@horizonhobby.com, or call 877.504.0233 toll free to speak to a service technician.

Inspection or Repairs

If this Product needs to be inspected or repaired, please call for a Return Merchandise Authorization (RMA). Pack the Product securely using a shipping carton. Please note that original boxes may be included, but are not designed to withstand the rigors of shipping without additional protection. Ship via a carrier that provides tracking and insurance for lost or damaged parcels, as Horizon is not responsible for merchandise until it arrives and is accepted at our facility. A Service Repair Request is available at www.horizonhobby.com on the "Support" tab. If you do not have internet access, please include a letter with your complete name, street address, email address and phone number where you can be reached during business days, your RMA number, a list of the included items, method of payment for any non-warranty expenses and a brief summary of the problem. Your original sales receipt must also be included for warranty consideration. Be sure your name, address, and RMA number are clearly written on the outside of the shipping carton.

Warranty Inspection and Repairs

To receive warranty service, you must include your original sales receipt verifying the proof-of-purchase date. Provided warranty conditions have been met, your Product will be repaired or replaced free of charge. Repair or replacement decisions are at the sole discretion of Horizon Hobby.

Non-Warranty Repairs

Should your repair not be covered by warranty the repair will be completed and payment will be required without notification or estimate of the expense unless the expense exceeds 50% of the retail purchase cost. By submitting the item for repair you are agreeing to payment of the repair without notification. Repair estimates are available

upon request. You must include this request with your repair. Non-warranty repair estimates will be billed a minimum of ½ hour of labor. In addition you will be billed for return freight. Please advise us of your preferred method of payment. Horizon accepts money orders and cashiers checks, as well as Visa, Master Card, American Express, and Discover cards. If you choose to pay by credit card, please include your credit card number and expiration date. Any repair left unpaid or unclaimed after 90 days will be considered abandoned and will be disposed of accordingly. Please note: non-warranty repair is only available on electronics and model engines.

Electronics and engines requiring inspection or repair should be shipped to the following address:

Horizon Service Center
4105 Fieldstone Road
Champaign, Illinois 61822

All other Products requiring warranty inspection or repair should be shipped to the following address:

Horizon Product Support
4105 Fieldstone Road
Champaign, Illinois 61822

Please call 877-504-0233 with any questions or concerns regarding this product or warranty.

Consumer Warranty and Repair Policy

Saito™ engines are guaranteed against workmanship and manufacturing defects for a period of 3 years from the original date of purchase. This warranty is limited to the original purchaser of the engine and is not transferable. Warranty repairs will **not** cover:

- Normal engine wear
- Damage due to insufficient maintenance
- Damage related to over-revving of engine due to small prop size or unreasonable use
- Rusted bearings
- Crash damage
- Damage due to use of improper fuel and/or glow plug
- Damage due to lean runs, such as rusted bearings, seized connecting rod or piston, etc.
- Damage caused by foreign objects (dirt or broken glow plug filaments)
- Damage caused by unreasonable mounting or running conditions (dust, insufficient cooling, improper mounting, improper propeller size, or lack of balancing, etc.)
- Damage due to improper disassembly
- Modifications of any kind
- Repair or replacement and any warranty coverage is Horizon's sole decision

Please cut on dotted line.



Consumer Warranty Registration

Complete this form and mail along with your dated sales receipt (send copy, keep original for your files) within 10 days of purchase to:

Horizon Service Center
 Attn: Saito Warranty Dept.
 4105 Fieldstone Road
 Champaign, IL 61822

Engine Type _____

Date of Purchase _____

Owner's Name _____

Street Address _____

City/State/Zip _____

Daytime Phone Number _____

Purchased From: _____

Dealer's Name _____

Street Address _____

City/State/Zip _____