

OPERATOR'S MANUAL

CRAFTSMAN[®]

P R O F E S S I O N A L

3/8 in. PROFESSIONAL CENTER HANDLE DRILL VARIABLE SPEED / REVERSIBLE / DUAL LASER DOUBLE INSULATED

Model No.
315.262520

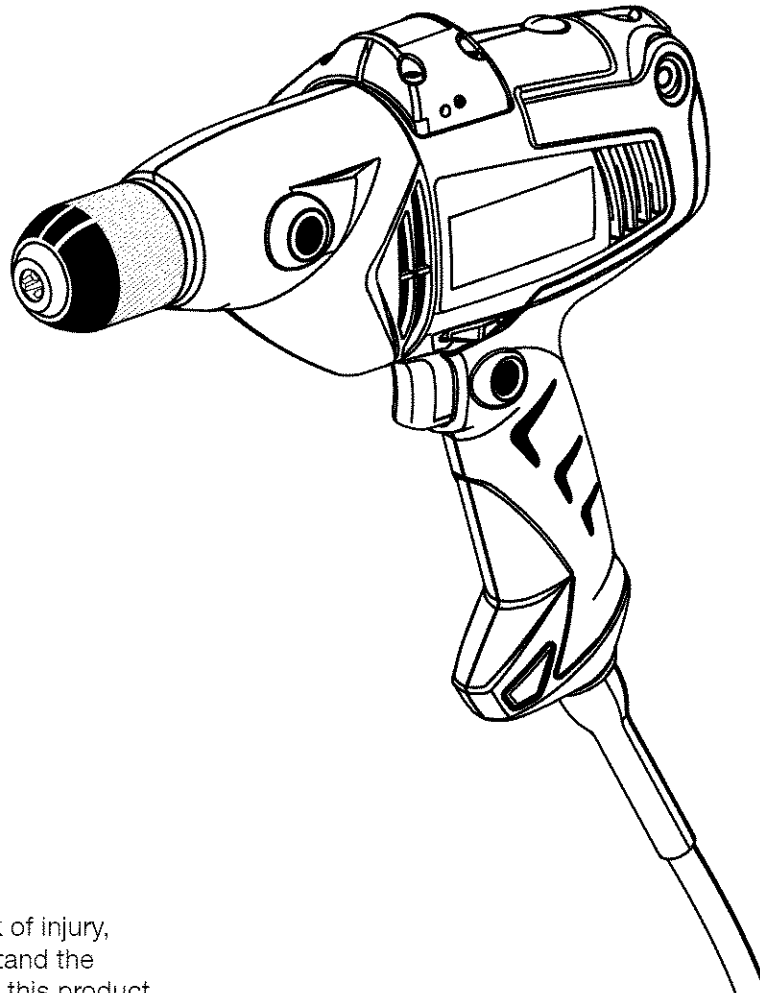

⚠ WARNING: To reduce the risk of injury, the user must read and understand the operator's manual before using this product.

Customer Help Line: 1-800-932-3188

Sears, Roebuck and Co., 3333 Beverly Rd., Hoffman Estates, IL 60179 USA
Visit the Craftsman web page: www.sears.com/craftsman

983000-729
8-05

Save this manual for future reference



TABLE OF CONTENTS

■ Warranty.....	2
■ Introduction.....	2
■ General Safety Rules	3-4
■ Specific Safety Rules.....	4-5
■ Symbols	6-7
■ Electrical	8
■ Features	9
■ Assembly	10
■ Operation.....	10-13
■ Adjustments.....	14-15
■ Maintenance	15-16
■ Accessories	16
■ Exploded View and Repair Parts List.....	17
■ Parts Ordering / Service	Back Page

WARRANTY

ONE-YEAR FULL WARRANTY ON CRAFTSMAN PROFESSIONAL TOOL

If this Craftsman Professional tool fails to give complete satisfaction within one year from date of purchase, **RETURN IT TO ANY SEARS STORE OR PARTS AND REPAIR CENTER OR OTHER CRAFTSMAN OUTLET IN THE UNITED STATES FOR FREE REPAIR.**

This warranty gives you specific legal rights, and you may also have other rights which vary from state to state.

Sears, Roebuck and Co., Dept. 817WA, Hoffman Estates, IL 60179

INTRODUCTION

This tool has many features for making its use more pleasant and enjoyable. Safety, performance, and dependability have been given top priority in the design of this product making it easy to maintain and operate.

GENERAL SAFETY RULES

⚠ WARNING! Read all instructions. Failure to follow all instructions listed below may result in electric shock, fire and/or serious injury. The term “power tool” in all of the warnings listed below refers to your mains-operated (corded) power tool or battery-operated (cordless) power tool.

SAVE THESE INSTRUCTIONS

WORK AREA SAFETY

- **Keep work area clean and well lit.** Cluttered or dark areas invite accidents.
- **Do not operate power tools in explosive atmospheres, such as in the presence of flammable liquids, gases, or dust.** Power tools create sparks which may ignite the dust or fumes.
- **Keep children and bystanders away while operating a power tool.** Distractions can cause you to lose control.

ELECTRICAL SAFETY

- **Power tool plugs must match the outlet. Never modify the plug in any way. Do not use any adapter plugs with earthed (grounded) power tools.** Unmodified plugs and matching outlets will reduce risk of electric shock.
- **Avoid body contact with earthed or grounded surfaces such as pipes, radiators, ranges and refrigerators.** There is an increased risk of electric shock if your body is earthed or grounded.
- **Do not expose power tools to rain or wet conditions.** Water entering a power tool will increase the risk of electric shock.
- **Do not abuse the cord. Never use the cord for carrying, pulling or unplugging the power tool. Keep cord away from heat, oil, sharp edges or moving parts.** Damaged or entangled cords increase the risk of electric shock.
- **When operating a power tool outdoors, use an extension cord suitable for outdoor use.** Use of a cord suitable for outdoor use reduces the risk of electric shock.

PERSONAL SAFETY

- **Stay alert, watch what you are doing and use common sense when operating a power tool. Do not use a power tool while you are tired or under the influence of drugs, alcohol or medication.** A moment of inattention while operating power tools may result in serious personal injury.
- **Use safety equipment. Always wear eye protection.** Safety equipment such as dust mask, non-skid safety shoes, hard hat, or hearing protection used for appropriate conditions will reduce personal injuries.
- **Avoid accidental starting. Ensure the switch is in the off-position before plugging in.** Carrying power tools with your finger on the switch or plugging in power tools that have the switch on invites accidents.

- **Remove any adjusting key or wrench before turning the power tool on.** A wrench or a key left attached to a rotating part of the power tool may result in personal injury.
- **Do not overreach. Keep proper footing and balance at all times.** This enables better control of the power tool in unexpected situations.
- **Dress properly. Do not wear loose clothing or jewelry. Keep your hair, clothing and gloves away from moving parts.** Loose clothes, jewelry or long hair can be caught in moving parts.
- **If devices are provided for the connection of dust extraction and collection facilities, ensure these are connected and properly used.** Use of these devices can reduce dust-related hazards.
- **Do not wear loose clothing or jewelry. Contain long hair.** Loose clothes, jewelry, or long hair can be drawn into air vents.
- **Do not use on a ladder or unstable support.** Stable footing on a solid surface enables better control of the power tool in unexpected situations.

POWER TOOL USE AND CARE

- **Do not force the power tool. Use the correct power tool for your application.** The correct power tool will do the job better and safer at the rate for which it was designed.
- **Do not use the power tool if the switch does not turn it on and off.** Any power tool that cannot be controlled with the switch is dangerous and must be repaired.
- **Disconnect the plug from the power source and/or the battery pack from the power tool before making any adjustments, changing accessories, or storing power tools.** Such preventive safety measures reduce the risk of starting the power tool accidentally.
- **Store idle power tools out of the reach of children and do not allow persons unfamiliar with the power tool or these instructions to operate the power tool.** Power tools are dangerous in the hands of untrained users.
- **Maintain power tools. Check for misalignment or binding of moving parts, breakage of parts and any other condition that may affect the power tool's operation. If damaged, have the power tool repaired before use.** Many accidents are caused by poorly maintained power tools.
- **Keep cutting tools sharp and clean.** Properly maintained cutting tools with sharp cutting edges are less likely to bind and are easier to control.
- **Use the power tool, accessories and tool bits etc., in accordance with these instructions and in the manner intended for the particular type of power tool, taking into account the working conditions and the work to be performed.** Use of the power tool for operations different from those intended could result in a hazardous situation.

GENERAL SAFETY RULES

SERVICE

- **Have your power tool serviced by a qualified repair person using only identical replacement parts.** This will ensure that the safety of the power tool is maintained.

 **WARNING!** To reduce risk of injury, user must read instruction manual.

- **When servicing a power tool, use only identical replacement parts. Follow instructions in the Maintenance section of this manual.** Use of unauthorized parts or failure to follow Maintenance instructions may create a risk of shock or injury.

SPECIFIC SAFETY RULES

- **Hold power tool by insulated gripping surfaces when performing an operation where the cutting tool may contact hidden wiring or its own cord.** Contact with a “live” wire will make exposed metal parts of the tool “live” and shock the operator.
- **Know your power tool. Read operator’s manual carefully. Learn its applications and limitations, as well as the specific potential hazards related to this power tool.** Following this rule will reduce the risk of electric shock, fire, or serious injury.
- **Always wear safety glasses. Everyday eyeglasses have only impact-resistant lenses; they are NOT safety glasses.** Following this rule will reduce the risk of serious personal injury.
- **Protect your lungs. Wear a face or dust mask if the operation is dusty.** Following this rule will reduce the risk of serious personal injury.
- **Protect your hearing. Wear hearing protection during extended periods of operation.** Following this rule will reduce the risk of serious personal injury.
- **Inspect power tool cords periodically and, if damaged, have repaired at your nearest Authorized Service Center. Constantly stay aware of cord location.** Following this rule will reduce the risk of electric shock or fire.
- **Check damaged parts. Before further use of the power tool, a guard or other part that is damaged should be carefully checked to determine that it will operate properly and perform its intended function. Check for alignment of moving parts, binding of moving parts, breakage of parts, mounting, and any other conditions that may affect its operation. A guard or other part that is damaged should be properly repaired or replaced by an authorized service center.** Following this rule will reduce the risk of shock, fire, or serious injury.
- **Make sure your extension cord is in good condition. When using an extension cord, be sure to use one heavy enough to carry the current your product will draw. A wire gauge size (A.W.G.) of at least 14 is recommended for an extension cord 50 feet or less in length. A cord exceeding 100 feet is not recommended. If in doubt, use the next heavier gauge. The smaller the gauge number, the heavier the cord.** An undersized cord will cause a drop in line voltage resulting in loss of power and overheating.
- **Inspect for and remove all nails from lumber before using this power tool.** Following this rule will reduce the risk of serious personal injury.
- **Save these instructions.** Refer to them frequently and use them to instruct others who may use this power tool. If you loan someone this power tool, loan them these instructions also.

SPECIFIC SAFETY RULES

LASER GUIDE WARNINGS:

The laser guide radiation used in this tool is Class IIIa with maximum <5 mW and 650nm wavelengths. These lasers do not normally present an optical hazard although staring at the beam may cause flash blindness.

- **Avoid** direct eye exposure when using the laser guide.
- The laser shall be used and maintained in accordance with the manufacturer's instructions.
- Never aim the beam at a person or object other than the workpiece.

- Always ensure the laser beam is aimed at a sturdy workpiece without reflective surfaces. Shiny reflective sheet metal or similar shiny materials are not suitable for laser use.
- All repairs should be made by an authorized service representative or the laser manufacturer.
- **Save these instructions.** Refer to them frequently and use them to instruct others who may use this power tool. If you loan someone this power tool, loan them these instructions also.











 **WARNING:** Some dust created by power sanding, sawing, grinding, drilling, and other construction activities contains chemicals known to cause cancer, birth defects or other reproductive harm. Some examples of these chemicals are:

- lead from lead-based paints,
- crystalline silica from bricks and cement and other masonry products, and
- arsenic and chromium from chemically-treated lumber.

Your risk from these exposures varies, depending on how often you do this type of work. To reduce your exposure to these chemicals: work in a well ventilated area, and work with approved safety equipment, such as those dust masks that are specially designed to filter out microscopic particles.



SYMBOLS

Some of the following symbols may be used on this tool. Please study them and learn their meaning. Proper interpretation of these symbols will allow you to operate the tool better and safer.

SYMBOL	NAME	DESIGNATION/EXPLANATION
V	Volts	Voltage
A	Amperes	Current
Hz	Hertz	Frequency (cycles per second)
W	Watt	Power
min	Minutes	Time
~	Alternating Current	Type of current
≡	Direct Current	Type or a characteristic of current
n_0	No Load Speed	Rotational speed, at no load
	Class II Construction	Double-insulated construction
.../min	Per Minute	Revolutions, strokes, surface speed, orbits etc., per minute
	Wet Conditions Alert	Do not expose to rain or use in damp locations.
	Read The Operator's Manual	To reduce the risk of injury, user must read and understand operator's manual before using this product.
	Eye Protection	Always wear safety goggles, safety glasses with side shields, or a full face shield when operating this product.
	Safety Alert	Precautions that involve your safety.
	No Hands Symbol	Failure to keep your hands away from the blade will result in serious personal injury.
	No Hands Symbol	Failure to keep your hands away from the blade will result in serious personal injury.
	No Hands Symbol	Failure to keep your hands away from the blade will result in serious personal injury.
	No Hands Symbol	Failure to keep your hands away from the blade will result in serious personal injury.
	Hot Surface	To reduce the risk of injury or damage, avoid contact with any hot surface.

SYMBOLS

The following signal words and meanings are intended to explain the levels of risk associated with this product.

SYMBOL	SIGNAL	MEANING
	DANGER:	Indicates an imminently hazardous situation, which, if not avoided, will result in death or serious injury.
	WARNING:	Indicates a potentially hazardous situation, which, if not avoided, could result in death or serious injury.
	CAUTION:	Indicates a potentially hazardous situation, which, if not avoided, may result in minor or moderate injury.
	CAUTION:	(Without Safety Alert Symbol) Indicates a situation that may result in property damage.

SERVICE

Servicing requires extreme care and knowledge and should be performed only by a qualified service technician. For service we suggest you return the product to your nearest **AUTHORIZED SERVICE CENTER** for repair. When servicing, use only identical replacement parts.



WARNING: To avoid serious personal injury, do not attempt to use this product until you read thoroughly and understand completely the operator's manual. Save this operator's manual and review frequently for continuing safe operation and instructing others who may use this product.

WARNING:



The operation of any power tool can result in foreign objects being thrown into your eyes, which can result in severe eye damage. Before beginning power tool operation, always wear safety goggles, safety glasses with side shields, or a full face shield when needed. We recommend Wide Vision Safety Mask for use over eyeglasses or standard safety glasses with side shields. Always use eye protection which is marked to comply with ANSI Z87.1.

SAVE THESE INSTRUCTIONS

ELECTRICAL

DOUBLE INSULATION

Double insulation is a concept in safety in electric power tools, which eliminates the need for the usual three-wire grounded power cord. All exposed metal parts are isolated from the internal metal motor components with protecting insulation. Double insulated tools do not need to be grounded.

⚠ WARNING: The double insulated system is intended to protect the user from shock resulting from a break in the tool's internal insulation. Observe all normal safety precautions to avoid electrical shock.

NOTE: Servicing of a tool with double insulation requires extreme care and knowledge of the system and should be performed only by a qualified service technician. For service, we suggest you return the tool to your nearest authorized service center for repair. Always use original factory replacement parts when servicing.

ELECTRICAL CONNECTION

This tool has a precision-built electric motor. It should be connected to a **power supply that is 120 volts, 60 Hz, AC only (normal household current)**. Do not operate this tool on direct current (DC). A substantial voltage drop will cause a loss of power and the motor will overheat. If your tool does not operate when plugged into an outlet, double-check the power supply.

EXTENSION CORDS

When using a power tool at a considerable distance from a power source, be sure to use an extension cord that has the capacity to handle the current the tool will draw. An undersized cord will cause a drop in line voltage, resulting in overheating and loss of power. Use the chart to determine the minimum wire size required in an extension cord. Only round jacketed cords listed by Underwriter's Laboratories (UL) should be used.

When working outdoors with a tool, use an extension cord that is designed for outside use. This type of cord is designated with "WA" on the cord's jacket.

Before using any extension cord, inspect it for loose or exposed wires and cut or worn insulation.

**Ampere rating (on tool faceplate)

0-2.0	2.1-3.4	3.5-5.0	5.1-7.0	7.1-12.0	12.1-16.0
-------	---------	---------	---------	----------	-----------

Cord Length	Wire Size (A.W.G.)					
25'	16	16	16	16	14	14
50'	16	16	16	14	14	12
100'	16	16	14	12	10	—

**Used on 12 gauge - 20 amp circuit

NOTE: AWG = American Wire Gauge

⚠ WARNING: Keep the extension cord clear of the working area. Position the cord so that it will not get caught on lumber, tools or other obstructions while you are working with a power tool. Failure to do so can result in serious personal injury.

⚠ WARNING: Check extension cords before each use. If damaged replace immediately. Never use tool with a damaged cord since touching the damaged

FEATURES

PRODUCT SPECIFICATIONS

Chuck 3/8 in., Keyless
Laser Guide Class IIIa, <5 mW max, 650nm
No Load Speed 0-2,500/min.

Switch Variable Speed
Input 120 V, 60 Hz, AC only, 6.0 Amps
Net Weight 4.4 lbs.
Power Cord 10 ft.

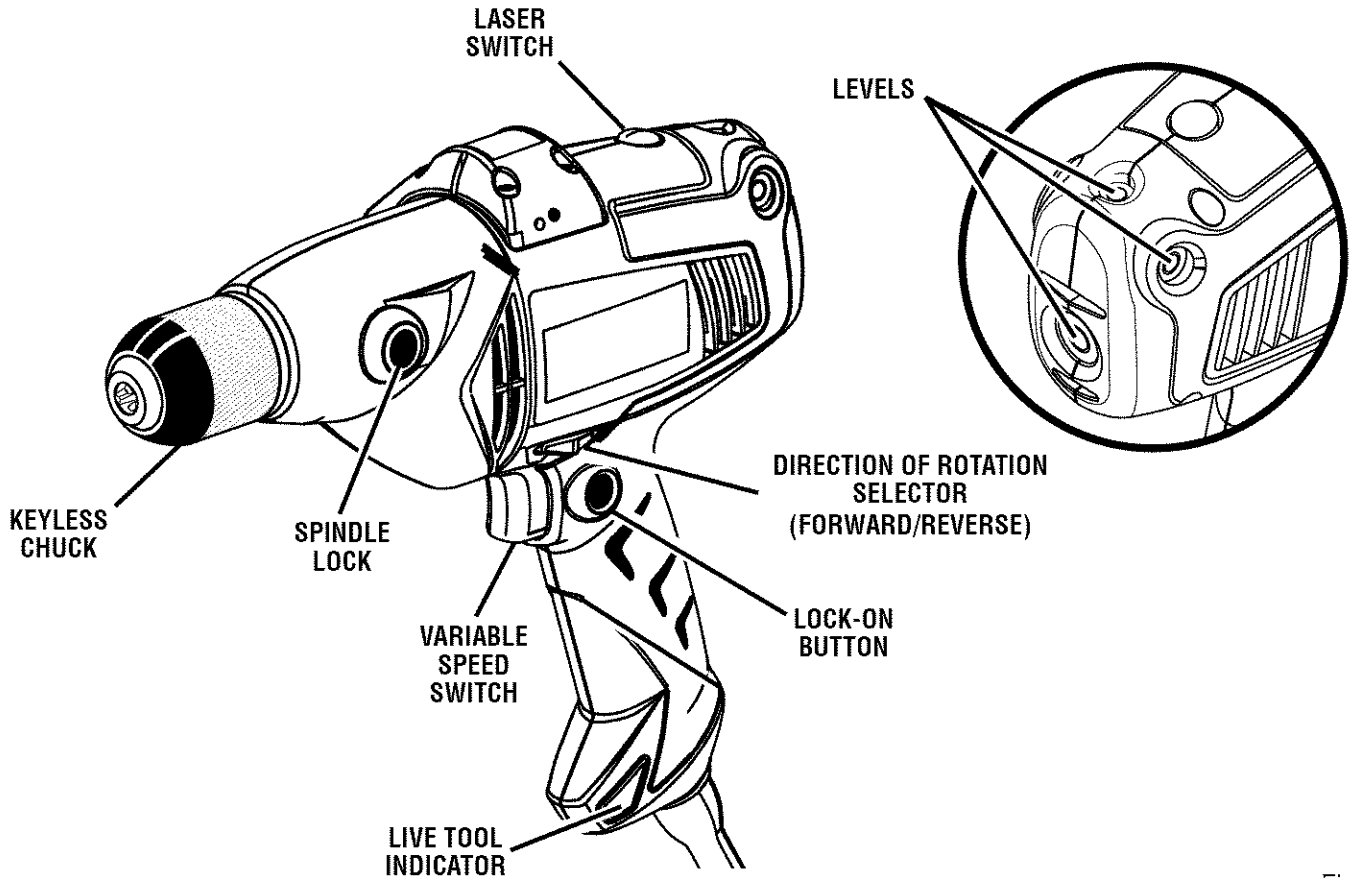

Fig. 1

KNOW YOUR DRILL

See Figure 1.

Before attempting to use this product, familiarize yourself with all operating features and safety rules.

DIRECTION OF ROTATION SELECTOR (FORWARD/REVERSE)

Your drill-driver has a direction of rotation (forward/reverse) selector located above the switch trigger for changing the direction of bit rotation.

DUAL LASERS

Dual lasers form 90° angles for aligning drill and screw holes.

KEYLESS CHUCK

The keyless chuck allows you to hand-tighten or release the drill bit in the chuck jaws.

LEVELS

Levels are located on the top, sides, and end of the motor housing to help keep the drill bit level during use.

LIVE TOOL INDICATOR

The live tool indicator is located on the handle of the drill and indicates that the tool is connected to a power supply.

LOCK-ON BUTTON

The lock-on button is convenient for continuous drilling for extended periods of time.

VARIABLE SPEED SWITCH

The variable speed switch delivers higher speed with increased trigger pressure and lower speed with decreased trigger pressure.

ASSEMBLY

UNPACKING

This product has been shipped completely assembled.

- Carefully remove the tool and any accessories from the box. Make sure that all items listed in the packing list are included.
- Inspect the tool carefully to make sure no breakage or damage occurred during shipping.
- Do not discard the packing material until you have carefully inspected and satisfactorily operated the tool.
- If any parts are damaged or missing, please call 1-800-932-3188 for assistance.

PACKING LIST

Center Handle Drill
Hex Key
Carrying Case
Operator's Manual

WARNING: If any parts are missing do not operate this tool until the missing parts are replaced. Failure to do so could result in possible serious personal injury.

WARNING: Do not attempt to modify this tool or create accessories not recommended for use with this tool. Any such alteration or modification is misuse and could result in a hazardous condition leading to possible serious personal injury.

WARNING: Do not connect to power supply until assembly is complete. Failure to comply could result in accidental starting and possible serious injury.

OPERATION

WARNING: Do not allow familiarity with tools to make you careless. Remember that a careless fraction of a second is sufficient to inflict serious injury.

WARNING: Always wear safety goggles or safety glasses with side shields when operating power tools. Failure to do so could result in objects being thrown into your eyes resulting in possible serious injury.

APPLICATIONS

You may use this tool for the purposes listed below:

- Drilling in wood
- Drilling in ceramics, plastics, fiberglass, and laminates
- Drilling in metals
- Mixing paint

VARIABLE SPEED SWITCH

See Figure 2.

To turn the drill **ON**, depress the variable speed switch. Release switch trigger to turn the drill **OFF**.

NOTE: You might hear a whistling or ringing noise from the switch during use. Do not be concerned; this is a normal part of the switch function.

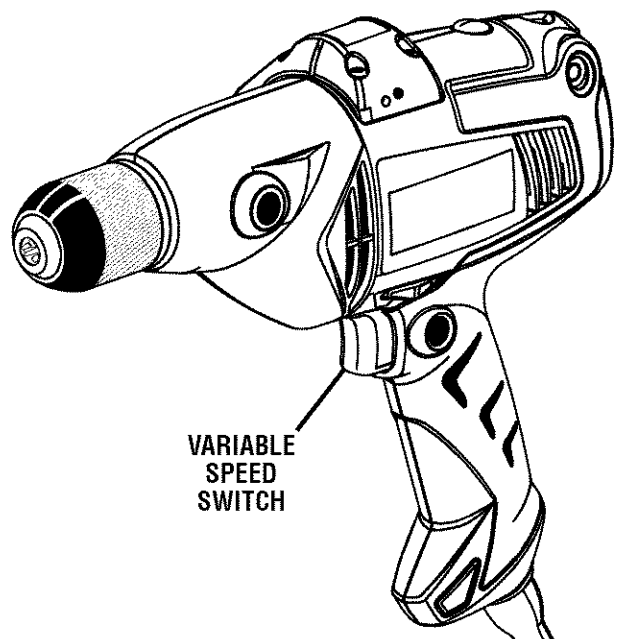

Fig. 2

OPERATION

KEYLESS CHUCK

See Figure 3.

The drill driver has a keyless chuck that makes it simple to tighten or release a drill bit in the chuck jaws. The arrows on the chuck indicate which direction to rotate the chuck body in order to **LOCK** (tighten) or **UNLOCK** (release) the drill bit.

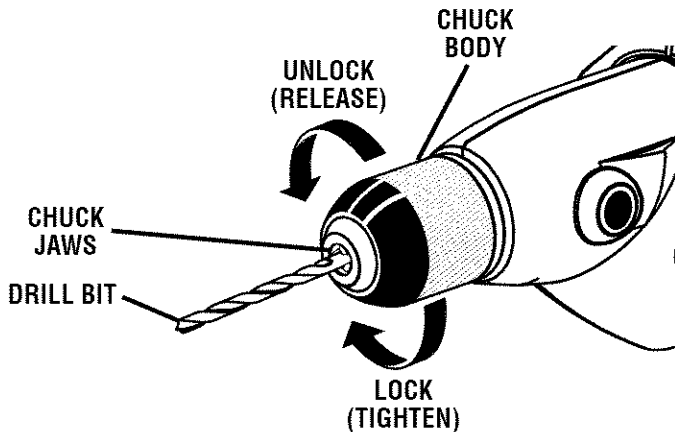

Fig. 3

WARNING: Do not hold the chuck body with one hand and use the power of the drill to tighten the chuck jaws on drill bit. The chuck body could slip in your hand or your hand could slip and come in contact with a rotating drill bit. This could cause an accident resulting in serious personal injury.

FORWARD/REVERSE

See Figure 4.

The direction of bit rotation is reversible and is controlled by a selector located above the switch trigger. With the drill held in normal operating position, the direction of rotation selector should be positioned to the left of the variable speed switch for drilling. The drill direction is reversed when the direction of rotation selector is to the right of the variable speed switch.

CAUTION: To prevent gear damage, always allow the chuck to come to a complete stop before changing the direction of rotation.

To stop the drill, release the variable speed switch and allow the chuck to come to a complete stop.

NOTE: The drill will not run unless the direction of rotation selector is pushed fully to the left or right.

Avoid running the drill at low speeds for extended periods of time. Running at low speeds under constant usage may cause the drill to become overheated. If this occurs, cool the drill by running it without a load at full speed.

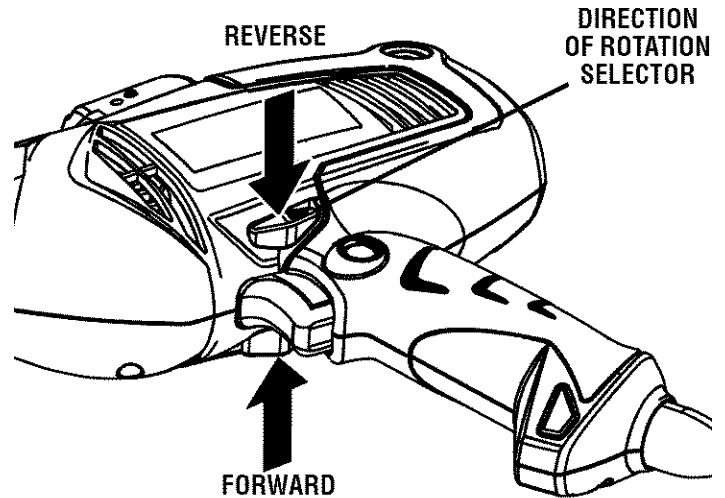

Fig. 4

WARNING: Always unplug the tool when installing or removing bits, adjusting settings, or when the tool is not in use. Failure to unplug the tool may result in accidental starting and serious personal injury.

SPINDLE LOCK

See Figure 5.

The spindle lock allows the user to keep the chuck from turning while changing bits and chucks.

- To lock the spindle, depress and hold the spindle lock button.
- While keeping the button depressed, rotate the chuck clockwise until the spindle clicks into a locked position and will not rotate further.
- To unlock, release the button.

NOTE: Always be sure the spindle lock button is released and the spindle lock is disengaged before turning the drill ON.

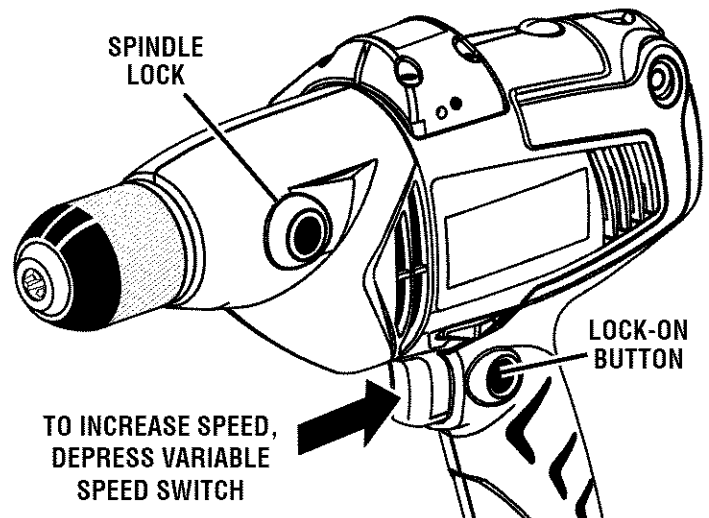

Fig. 5

OPERATION

INSTALLING BITS

See Figures 6 - 7.

- Unplug the drill.
- Lock the spindle.
- Open or close the chuck jaws to a point where the opening is slightly larger than the bit size you intend to use. Also, raise the front of the drill slightly to keep the bit from falling out of the chuck jaws.
- Insert the drill bit.

⚠ WARNING: Make sure to insert the drill bit straight into the chuck jaws. Do not insert the drill bit into the chuck jaws at an angle then tighten, as shown in figure 7. This could cause the drill bit to be thrown from the drill, resulting in possible serious personal injury or damage to the chuck.

- Rotate the chuck clockwise to tighten the chuck jaws securely on the bit.

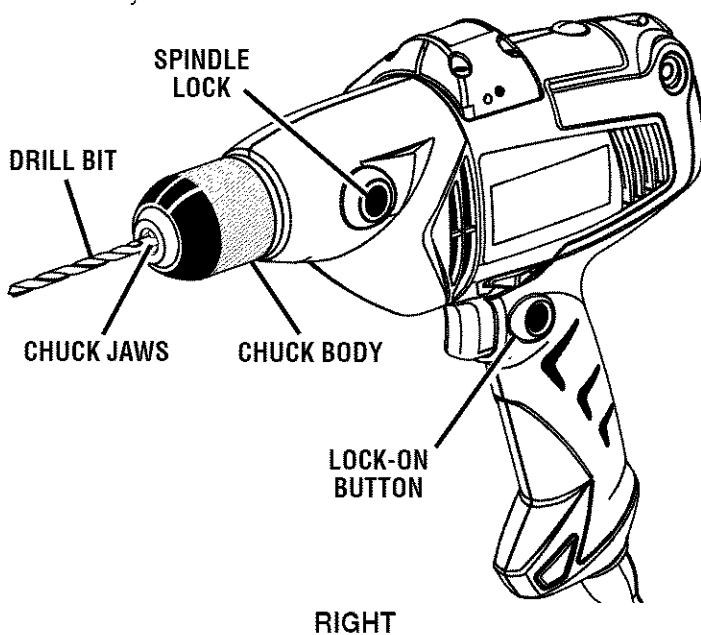

Fig. 6

NOTE: Rotate the chuck body in the direction of the arrow marked **LOCK** to tighten the chuck jaws. Do not use a wrench to tighten or loosen the chuck jaws.

- Release the spindle lock button.

REMOVING BITS

See Figure 6.

- Unplug the drill.
- Depress the spindle lock button.
- While keeping the button depressed, rotate the chuck in either direction until it clicks into a position that will not allow it to rotate.

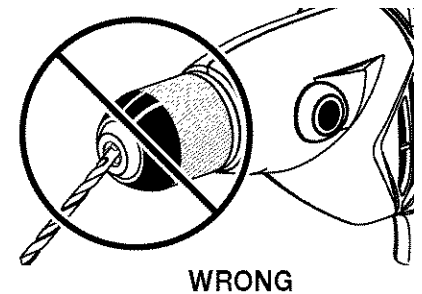

Fig. 7

- Keeping the spindle lock button depressed, rotate the chuck clockwise to open the chuck jaws.
- Remove the drill bit.
- Release the spindle lock button

LOCK-ON BUTTON

See Figure 6.

This drill is equipped with a lock-on feature, which is convenient for continuous drilling for extended periods of time. To lock-on:

- Depress the variable speed switch.
- Push in and hold the lock-on button, located on the side of the handle.
- Release the switch trigger.
- Release the lock-on button and the drill will continue running.
- To release the lock, depress and release the variable speed switch.

If the lock-on feature is engaged during use and the drill becomes disconnected from the power supply, disengage the lock-on feature immediately.

USING THE LASER GUIDE

See Figure 8.

⚠ WARNING: To avoid possible injury, do not stare into the laser beam. The laser unit comes from the factory already installed and aligned, but if the laser becomes misaligned after time, refer to the Adjustments section.

- Plug in the drill.
- Aim the drill towards a wall.
- Depress the laser switch. The drill will project two lines in a 90° right angle on the wall.
- Using the levels to keep laser lines level, project the laser lines on the wall.

OPERATION

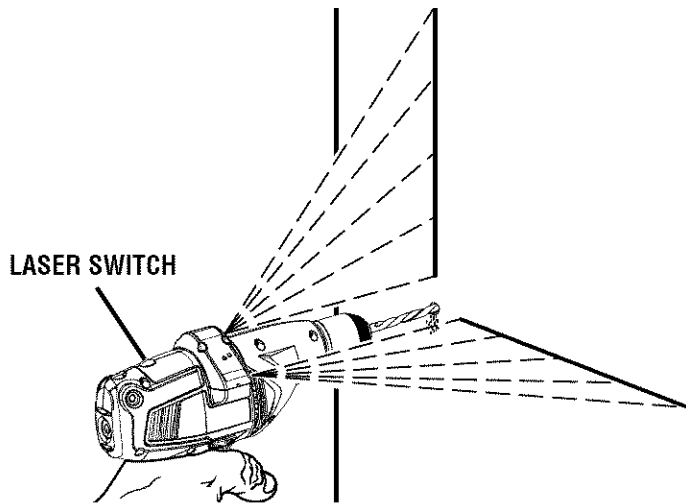

Fig. 8

WARNING: Before connecting the drill to a power supply source, always check to be sure it is not in lock-on position (depress and release the variable speed switch). Failure to ensure that it is not locked-on could result in accidental starting of the drill resulting in possible serious injury. Do not lock the variable speed switch in applications where the drill may need to be suddenly stopped.

DRILLING

See Figures 9 - 10.

Levels are located on the top and end of the motor housing to help keep the drill bit level during use.

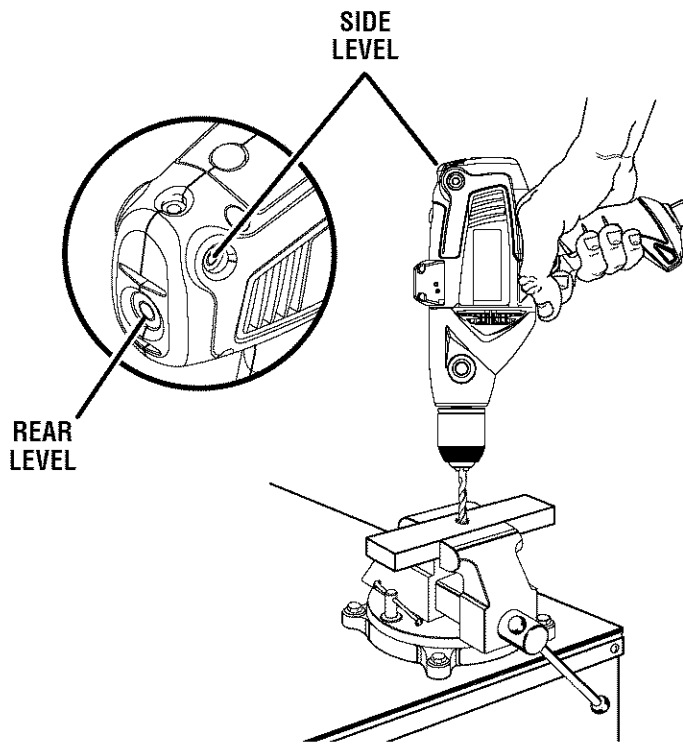

Fig. 9

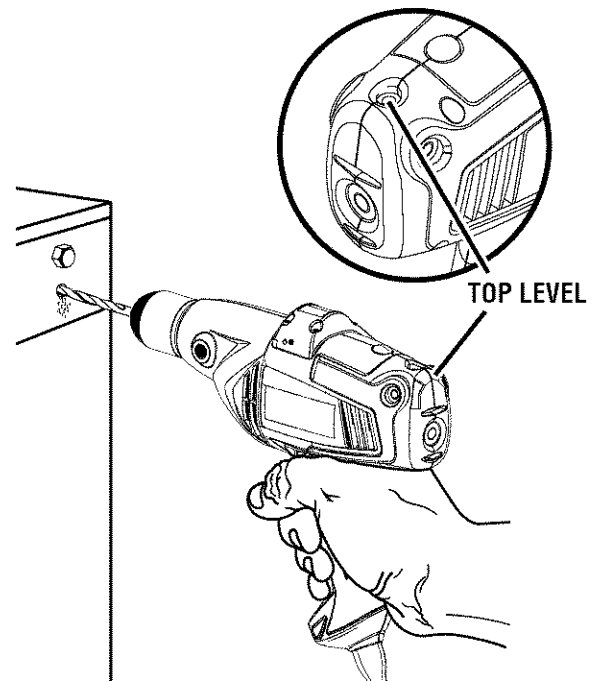

Fig. 10

- Depress and release the variable speed switch to be sure the drill is in **OFF** position before connecting it to a power supply.
- Check the direction of rotation selector for correct setting (forward or reverse).
- Secure the material to be drilled in a vise or with clamps to keep it from turning as the drill bit rotates.
- Plug the drill into power supply. Hold the drill firmly and place bit at point to be drilled.
- Depress the variable speed switch to start the drill.
- Move the drill bit into the workpiece applying only enough pressure to keep the bit cutting. Do not force the drill or apply side pressure to elongate a hole. Let the drill and bit do the work.

WARNING: Be prepared for binding at bit breakthrough. When these situations occur, the drill has a tendency to grab and kick in the opposite direction and could cause loss of control when breaking through material. If not prepared, this loss of control can result in possible serious injury.

- When drilling hard, smooth surfaces use a center punch to mark the desired hole location. This will prevent the drill from slipping off center as the hole is started.
- When drilling metals use a light oil on the drill bit to keep it from overheating. The oil will prolong the life of the bit and increase the drilling action.
- If the bit jams in the workpiece or if the drill stalls, stop the tool immediately. Remove the bit from the workpiece and determine the reason for jamming.

ADJUSTMENTS

CAUTION: Use of controls or adjustments or performance of procedures other than those specified herein may result in hazardous radiation exposure.

ADJUSTING THE LASER

See Figures 11 - 13.

- Unplug the drill.
- Facing a wall, center the bubble in the top level.
- Clamp the drill in a vice or other clamp so that the laser lines project onto a wall.

NOTE: For accurate measurements, do not exceed a 3 ft. distance from the nearest wall. Otherwise, laser lines may not intersect properly for perpendicular measurements.

- Connect the drill to a power supply.
- Turn on the laser.



WARNING: DO NOT point the laser at yourself or others. Class IIIa lasers will burn the retinas and could cause serious injury to the eyes.

- Use a level and a framing square to take measurements of the laser lines on the wall to determine what adjustments are needed.

NOTE: Use a level to check the horizontal and vertical laser lines. A framing square or level can be used to check if the laser lines are perpendicular. The laser lines should project a 90° angle.

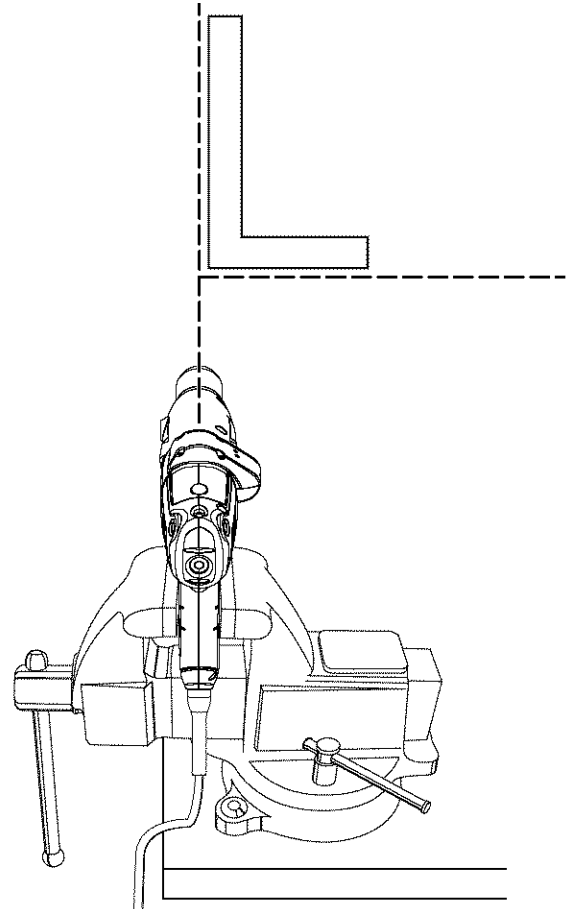
Make adjustments with the drill clamped in place and the lasers facing away from the user.



 Complies with 21CFR parts 1040.10 and 1040.11, April 1, 2003 Sears, Roebuck and Co., Hoffman Estates, IL 60179 USA 1894-T4HD	⚠ DANGER AVOID EXPOSURE Laser radiation is emitted from these apertures.	Laser radiation - avoid direct eye exposure.  Max Output <5mW Wavelength: 650nm Class IIIa laser product SEST
---	--	--

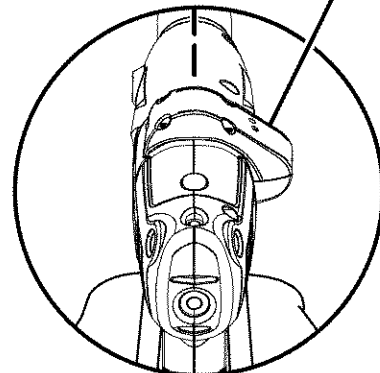

Fig. 11

ADJUSTMENTS

Making vertical laser line adjustments

See Figure 12.

- The front screw moves the laser line, changing the angle. Turn the screw clockwise to angle the top edge of the laser line to the left. Counterclockwise will angle the laser line to the right.
- The rear screw moves the laser line right to left. Turning the screw clockwise moves the laser line right. Counterclockwise moves the laser line left along the horizontal axis.

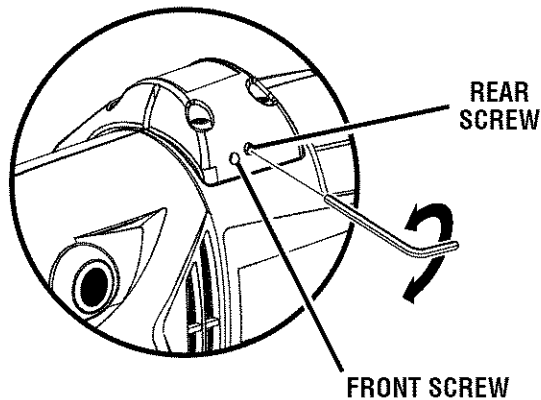

Fig. 12

Making horizontal laser line adjustments

See Figure 13.

- The front screw rotates the laser line to change the angle. Turn the screw clockwise to angle the right edge of the laser line up. Turn the screw counterclockwise to angle the laser line down.
- The rear screw moves the laser line up and down. Turning the screw clockwise moves the laser line down. Counterclockwise moves the laser line up the vertical axis.

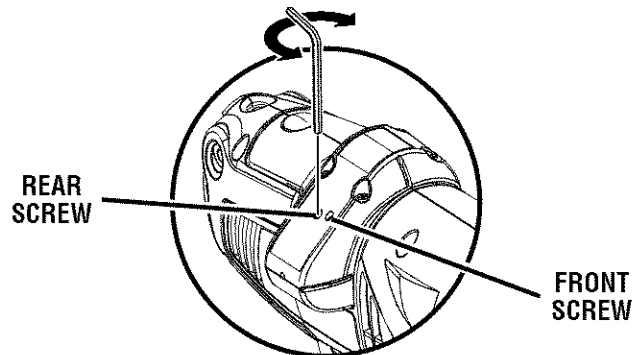

Fig. 13

MAINTENANCE

WARNING: When servicing, use only identical Craftsman replacement parts. Use of any other parts may create a hazard or cause product damage.

WARNING: Always wear safety goggles or safety glasses with side shields during power tool operation or when blowing dust. If operation is dusty, also wear a dust mask.

GENERAL MAINTENANCE

Avoid using solvents when cleaning plastic parts. Most plastics are susceptible to damage from various types of commercial solvents and may be damaged by their use. Use clean cloths to remove dirt, dust, oil, grease, etc.

WARNING: Do not at any time let brake fluids, gasoline, petroleum-based products, penetrating oils, etc., come in contact with plastic parts. Chemicals can damage, weaken or destroy plastic which may result in serious personal injury.

Electric tools used on fiberglass material, wallboard, spackling compounds, or plaster are subject to accelerated wear and possible premature failure because the fiberglass chips and grindings are highly abrasive to bearings, brushes, commutators, etc. Consequently, we do not recommend using this tool for extended work on these types of materials. However, if you do work with any of these materials, it is extremely important to clean the tool using compressed air.

LUBRICATION

All of the bearings in this tool are lubricated with a sufficient amount of high grade lubricant for the life of the unit under normal operating conditions. Therefore, no further lubrication is required.

Only the parts shown on the parts list are intended to be repaired or replaced by the customer. All other parts should be replaced at a Sears Service Center.

MAINTENANCE

CHUCK REMOVAL

See Figures 14 - 16.

The chuck may be removed and replaced with a new one.

- Unplug the drill.
- Insert a 5/16 in. or larger hex key into the chuck of the drill and tighten the chuck jaws securely.
- Tap the hex key sharply with a mallet in a clockwise direction. This will loosen the screw in the chuck for easy removal.

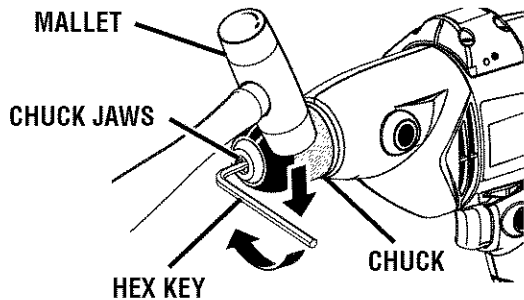

Fig. 14

- Open the chuck jaws and remove the hex key. Using a screwdriver, remove the chuck screw by turning it in a clockwise direction.

NOTE: The chuck screw has left hand threads.

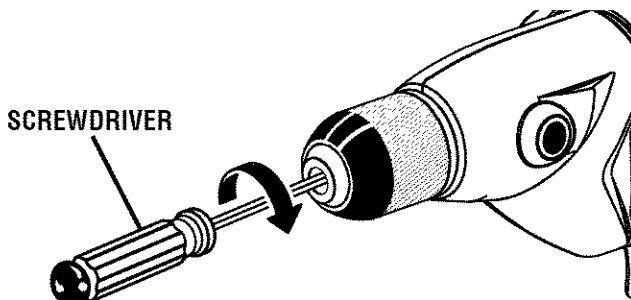

Fig. 15

- Insert the hex key into the chuck and tighten the chuck jaws securely. Tap sharply with a mallet in a counter-clockwise direction. This will loosen the chuck on the spindle. It can now be unscrewed by hand.

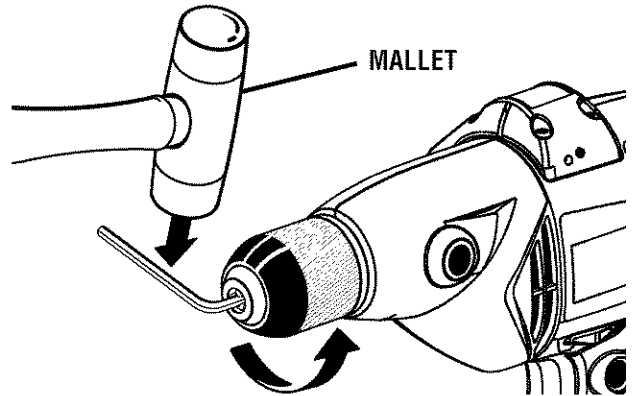

Fig. 16

TO RETIGHTEN A LOOSE CHUCK

The chuck may become loose on the spindle and develop a wobble. Also, the chuck screw may become loose, causing the chuck jaws to bind and prevent them from closing. To tighten:

- Unplug the drill.
- Open the chuck jaws.
- Insert a hex key into the chuck and tighten chuck jaws securely. Tap the hex key sharply with a mallet in a clockwise direction. This will tighten the chuck on the spindle.
- Open the chuck jaws and remove the hex key.
- Tighten the chuck screw.

ACCESSORIES

Look for these accessories at Sears retail:

- High Speed Bits (For wood or metal) 1/2 in. Max.
- Masonry Bits..... 3/4 in. Max.
- Wood Boring Bits 1 in. Max.
- Hole Saws 2 in. Max.
- Doweling Jig
- Drill Stand
- Wire Brushes, All

⚠ WARNING: Current attachments and accessories available for use with this tool are listed above. Do not use any attachments or accessories not recommended by the manufacturer of this tool. The use of attachments or accessories not recommended can result in serious personal injury.

CRAFTSMAN 3/8 in. PROFESSIONAL ELECTRIC DRILL MODEL NO. 315.262520

The model number will be found on a plate attached to the motor housing. Always mention the model number in all correspondence regarding your **DRILL** or when ordering repair parts.

SEE BACK PAGE FOR PARTS ORDERING INSTRUCTIONS

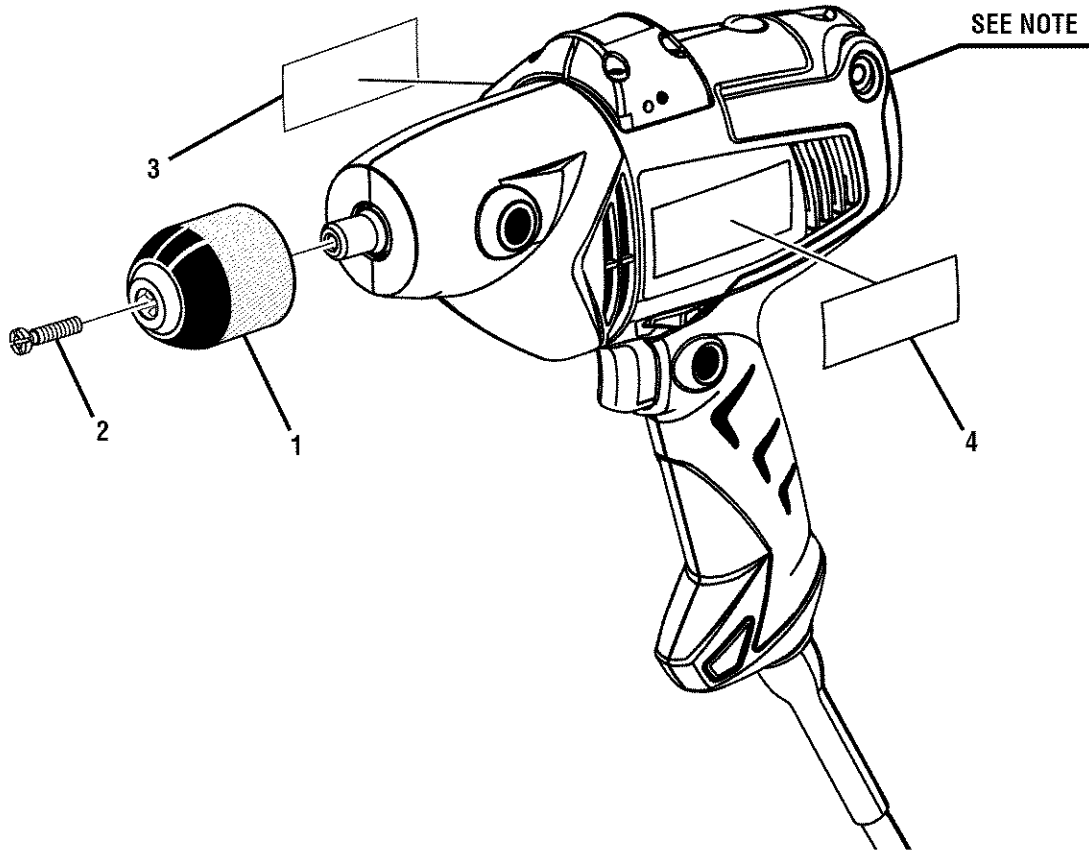

PARTS LIST

Key No.	Part Number	Description	Qty.
1	690033045	3/8 in Chuck.....	1
2	6611903	Screw (special).....	1
3	940078060	Data Plate.....	1
4	940051031	Logo Plate.....	1
	983000729	Operator's Manual	

Note: The assembly shown represents an important part of the double insulated system. To avoid the possibility of alteration or damage to the system, service should be performed by your nearest Sears repair center. Contact your nearest Sears retail store for service center information.

Get it fixed, at your home or ours!

Your Home

For repair – **in your home** – of **all** major brand appliances, lawn and garden equipment, or heating and cooling systems, **no matter who made it, no matter who sold it!**

For the replacement parts, accessories and owner's manuals that you need to do-it-yourself.

For Sears professional installation of home appliances and items like garage door openers and water heaters.

1-800-4-MY-HOME® (1-800-469-4663)

Call anytime, day or night (U.S.A. and Canada)

www.sears.com www.sears.ca

Our Home

For repair of carry-in items like vacuums, lawn equipment, and electronics, call or go on-line for the location of your nearest **Sears Parts & Repair Center.**

1-800-488-1222

Call anytime, day or night (U.S.A. only)

www.sears.com

To purchase a protection agreement (U.S.A.) or maintenance agreement (Canada) on a product serviced by Sears:

1-800-827-6655 (U.S.A.)

1-800-361-6665 (Canada)

Para pedir servicio de reparación a domicilio, y para ordenar piezas:

1-888-SU-HOGARSM

(1-888-784-6427)

Au Canada pour service en français:

1-800-LE-FOYER^{MC}

(1-800-533-6937)

www.sears.ca



® Registered Trademark / TM Trademark / SM Service Mark of Sears, Roebuck and Co.

® Marca Registrada / TM Marca de Fábrica / SM Marca de Servicio de Sears, Roebuck and Co.

^{MC} Marque de commerce / ^{MD} Marque déposée de Sears, Roebuck and Co.

© Sears, Roebuck and Co.