

STRATA 1



**WALL MOUNTED, GAS FIRED,
ULTRA HIGH EFFICIENCY CONDENSING BOILER
INSTRUCTIONS FOR INSTALLATION, SERVICING
& OPERATION FOR MODELS 45, 60 & 75**



MHS
BOILERS

Index

page	section	
3	1.0	General Notes
	2.0	Product Description
4	2.0	Product Description (contd)
5	3.0	Technical Data & Dimensions
6	4.0	Delivery Consignment/Unpacking The Boiler
	5.0	Boiler Location
	6.0	Installation Clearances
7	7.0	Wall Mounting
	8.0	Gas Connection
8	9.0	System Flow & Return Connections
	10.0	Condense Waste Connection
9	10.0	Condense Waste Connection (contd)
	11.0	Flue Combustion Air Connection - General
10	12.0	Conventional Flue Installation
11-17	13.0	Room Sealed Flue Installations
18	14.0	Examples of Calculating Flue Pressure Loss
19-20	14.0	Calculating Flue Resistance
	15.0	Flue Terminal Positions
21-22	16.0	Ventilation Requirements Single Appliances
23-32	17.0	Hydraulic system Design (circuit diagrams)
32	17.1	Water Treatment System Cleaning
	17.2	Inclusion of Strainers
	17.3	Low Water Pressure Protection
33	17.4	Care With The Use of Soldering Flux
	18.0	Electrical Connections
34-43	18.0	Electrical Connections (contd)
43	18.1	0-3/0-10 Volt Control
	19.0	Commissioning The Strata 1 Boiler
44	19.1	Pre-Commissioning Checks
	19.3	First Firing
45	19.2	Dip Switch Settings
46-47	19.3	First Firing (contd)
47-49	19.4	Setting Weather Compensation
50	19.5	Setting Domestic Hot Water Temperature
	19.6	Service Button/Setting Heating Output
51	19.6	Service Button/Setting Heating Output (contd)
	19.7	Output For Charging Hot Water
	20.0	Setting The Boiler To Work
52-53	21.0	Servicing Instruction
	21.1	Inspection
	21.2	Maintenance
54-57	22.0	Screen Display/Diagnosis Of Faults
	22.1	Screen Display/Diagnosis Of Faults
56-57	22.2	(Possible) Causes Of Fault & Corrective Action
58	23.0	Instructing The User

1.0 general *notes*

These instructions are intended to assist the installer, commissioning engineer, maintenance engineer and user with the installation, maintenance and usage of Strata 1, 45, 60 and 75 models gas fired condensing boilers.

Please read this manual fully before commencing the installation of the appliance. The Strata 1 must only be installed by persons deemed to be competent i.e. Corgi Registered. This manual must be handed to the appliance user following completion of the installation.

2.0 product *description*

The Strata 1 range of wall mounted gas fired condensing boilers are state of the art appliances which include a comprehensive range of features. The appliance must only be used on sealed and pressurised systems. System design must take into account the boiler operating Δt of 20°C.

wall mounted with compact dimensions

At 900H x 458W x 435D, the Strata 1 boiler provides maximum heat from minimum dimensions without compromising serviceability.

fully modulating heat output

The output of the boiler is fully variable, sliding between (approx.) 20% to 100%, which automatically and instantly adjusts to match the needs of the system. The percentage of power at any given time can be dictated by either outside air temperature, flow temperature, return temperature, stored domestic hot water temperature, or room temperature, or a combination of the aforementioned.

fully condensing stainless steel heat exchanger

The Strata 1 boiler is designed with extended heat exchange surface area and is fabricated from corrosion resistant long-life stainless steel. The unique SpiranoX heat exchanger will return operating efficiencies from 86% gross (96% nett) at 60°C return temperature, up to 97% gross (107% nett), at 30°C return temperature.

extremely low harmful emissions

The boiler utilises 100% pre-mix gas/air fed at positive pressure to the metal fibre sheathed radiant burners. The combustion system incorporates internal flue gas re-circulation and this combined with the precise nature of pre-mix fuel/air control, gives ultra low emissions to satisfy the most stringent emission regulations in the world currently. That is: < 20mg/kWh NO_x (14 ppm DAF) and < 14mg/kWh CO (13 ppm DAF). The fully modulating nature of the appliance also reduces emissions by avoiding repeated start/stops and the associated increase in emissions, which occurs with burner on/off cycling.

accurate variable burner output control

The pre-mix burner fans have low voltage direct current drive motors with pulse relay counting. This system allows precise control over fan speed/combustion air volumes. Coupled with a gas valve system set to provide proportionately measured volumes of fuel to air, which allows extremely accurate and instant variable burner output control to be achieved.

2.0 product description (contd)

energy saving

In addition to the extremely efficient burner and heat exchanger system employed in the Strata 1, each appliance includes a modulating speed boiler primary pump.

This feature allows the boiler to self-maintain a 20°C Δt across the heat exchanger, optimising the heat exchanger efficiency and reducing also the electrical consumption of the pump motors. The result is a seasonal increase in boiler efficiency of a further 7-10% and a reduction in pump electricity consumption of up to 70%.

natural gas or LPG

Appliances can be supplied for use with natural gas (G20) or LPG (G31).

comprehensive microprocessor control

The boiler control panel includes a user friendly microprocessor control centre which manages the entire function of the appliance and encompasses:-

1. Management of the essential safety functions of burner ignition and flame monitoring.
2. Water high temperature and flue gas high temperature safety cut out.
3. Modulation of the boiler output and pump speeds in conjunction with operating temperature control.
4. LCD display screen with two lines of text to continuously display operational or fault status.
5. In built weather compensator to provide direct-on boiler VT flow temperature (if required).
6. Remote stored hot water temperature control.
7. In built 2 stage boiler frost protection program.
8. In built pump exercising program to avoid standstill seizure.
9. Cold start boost facility.
10. PC compatibility with data logging which allows communication with the boiler via a lap-top computer to review/modify operational parameters and access operational history as an aid to fault finding and preventative maintenance.
11. Range rate adjustment which allows the power to be set to accurately match the maximum needs of the system, with the facility to set a different firing rate for heating. Output to hot water self adjusts to the heat transfer capability of the calorifier.
12. Facility to connect optional matched control components which allow the boiler to control a heating circuit pump, HWS primary pump or diverter valve and an underfloor circuit mixing valve and pump, plus the ability for the boiler to be controlled by a remote multi function modulating room unit.
Multiple boilers may be connected to a modulating Kaskade manager which further enhances the operating efficiency of a larger load modular boiler system.

room sealed option

If required, the boiler may be installed to be completely room sealed, taking combustion air directly from outside the building, using a 125/80 concentric air duct/flue duct system. Inherent safety is afforded by the negative pressure within the boiler casing, which in the event of incorrect sealing results in safe inward air leakage only.

extended flue lengths

The excess fan pressure from the combustion system is 100 Pa, which allows the appliance to be exhausted using small diameter PPS plastic flue components, over long distances, allowing for complete flexibility in boiler siting.

designed for ease of maintenance

Although compact, the Strata 1 does not compromise serviceability. The appliance has been engineered to be easy to maintain with even the most major of service operations being able to be completed easily and quickly with the minimum of tools.

guarantee

The heat exchanger carries a five year guarantee against manufacturing or material defect.

3.0 technical data & dimensions

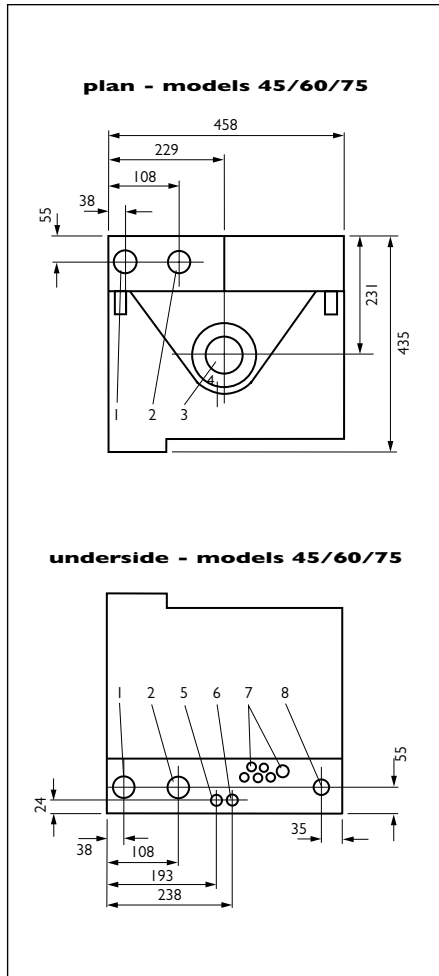

Model	Strata I	45	60	75
Nominal Heat Input Nett (max)	kW	43	57	72
Nominal Heat Output 80/60°C	kW	41.3	54.7	69.1
Nominal Heat Output 50/30°C	kW	45.2	59.9	75.6
Input Rate Nat Gas (max)	m ³ /h	4.7	5.9	7.6
Input Rate LPG G31 (max)	m ³ /h	1.76	2.33	2.95
Minimum/Maximum Gas Pressure	mbar	15/60	15/60	15/60
Flue Gas Volume (Hot)	m ³ /h	64	81	104
Pressure at Flue Outlet	Pa	100	100	100
Maximum Working Pressure	Bar	3.0	3.0	3.0
Minimum Working Pressure	Bar	0.5	0.5	0.5
Maximum Flow Temperature	°C	85	85	85
Power Supply	V	230	230	230
Fuse Rating	A	3.0	3.0	3.0
Average Power Consumption	Watts	115	115	115
Water Content	L	6	7	8
Weight (Dry)	kg	60	66	73
Design Δt	°C	20	20	20

pH of Condense Water 4 to 5.5

Connection	Strata I	45	60	75
1. Return	1 1/4" BSP-M	1 1/4" BSP-M	1 1/4" BSP-M	1 1/4" BSP-M
2. Flow	1 1/4" BSP-M	1 1/4" BSP-M	1 1/4" BSP-M	1 1/4" BSP-M
3. Flue Gas (OD)	80mm	80mm	80mm	80mm
4. Air Duct (OD)	125mm	125mm	125mm	125mm
5. Condense Syphon Cleaning Point (capped)	3/4" BSP	3/4" BSP	3/4" BSP	3/4" BSP
6. Condense Waste	3/4" BSP-M	3/4" BSP-M	3/4" BSP-M	3/4" BSP-M
7. Cable Entries	Multiple Grometts			
8. Gas	3/4" BSP-M	3/4" BSP-M	3/4" BSP-M	3/4" BSP-M

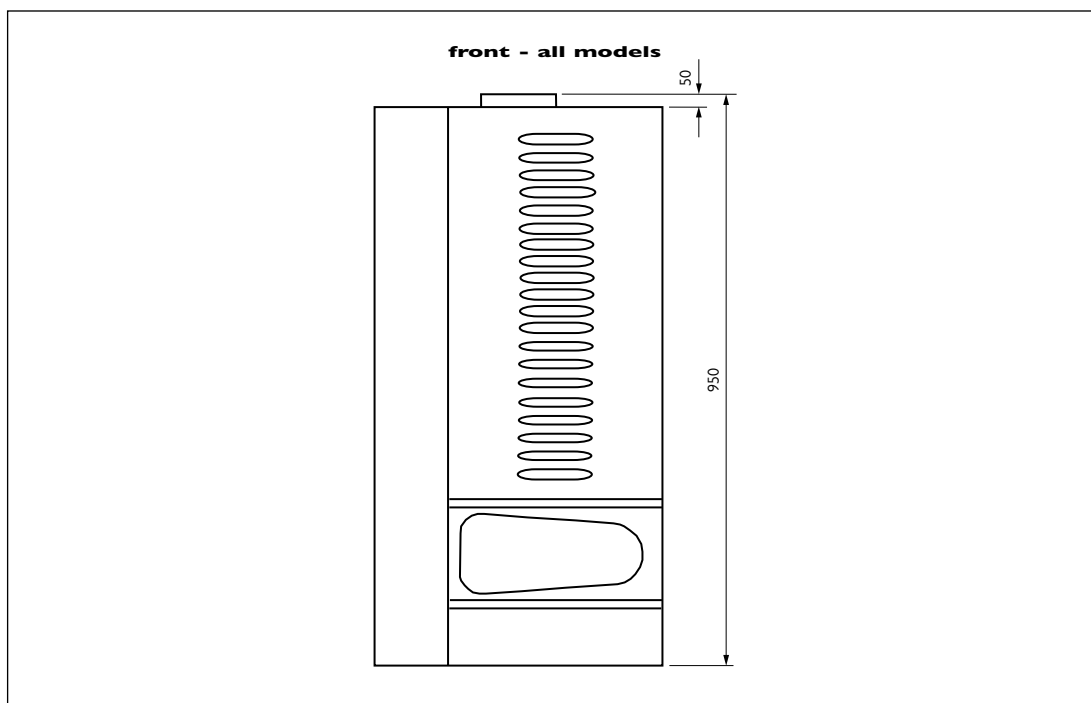

4.0 delivery consignment */unpacking the boiler*

The boiler is delivered as a consignment of a carton containing the boiler and associated fittings, plus any other optional ancillary flue or control components in separate cartons.

The boiler carton contains:-

- Assembled boiler
- Wall mounting bracket
- Fittings carton including 2Nr 1 1/4" x 1 1/4" x 1/2" BSP Tees, 2Nr 1 1/4" x 1/2" BSP reducing sockets, 1Nr 3/4" BSP Inlet x 1" BSP outlet safety valve set 3.0 bar, 1Nr 3/4" x 1/2" BSP reducing nipple (for safety valve inlet) and 1Nr outside air temperature sensor.

To unpack the boiler, the carton should be laid on the floor with the top carton seam uppermost. Carefully remove tape from seam and open carton flaps, remove packing material, wall mounting bracket and fittings carton. For ease of boiler handling from the carton it is suggested that the carton be slit down each corner and the carton sides laid out flat. The boiler should only be lifted by contact with the rear (grey) chassis assembly.

To remove the casing from the boiler, slacken the screw in the underside of the casing, unlatch left and right hand catches on underside of case, pull casing slightly to the front and lift upwards to disengage casing hooks from rear chassis and then remove casing to the front.

5.0 boiler *location*

The Strata 1 Boiler is not suitable for installation external to a building. The position chosen for the boiler must be a structurally sound wall capable of supporting the weight of the boiler and any ancillaries. The position should allow for access to a condense waste drain nearby or an alternative is to install a condense sump receptacle and condense disposal pump which should remove the condense waste water to a remote drain. The wall mounting position of the boiler must allow the boiler to be true plumb vertical to ensure correct operation of the internal gravity flow condense system. The position for the boiler must satisfy the requirements of BS6798:1987 or BS6644:1991.

6.0 installation *clearances*

For ease of installation, commissioning and maintenance the following minimum clearances should be observed.

Sides	50mm
Above	250mm
Below	150mm
Front	450mm

7.0 wall mounting

The Strata 1 boiler mounts to the wall via a wall mounting bracket which interlocks to a rail mounted upon the rear of the boiler. The wall mounting bracket should be firmly fixed to the wall using suitable fixings with a countersunk head. The wall mounting bracket positioning detail is shown in fig 1. The boiler must be carefully offered up to the wall so that the rail on the rear of the boiler is just above the wall mounting bracket and then the boiler should be lowered to engage the bracket and rail. Lifting is advised with 2 persons. Do **NOT** lift the boiler by the internal parts of the appliance.

important

When viewed from the side, the north/south axis of the boiler must be vertical. The appliance must not be inclined out from the top, if necessary block or shim behind the bottom rear of the boiler to achieve a vertical installation.

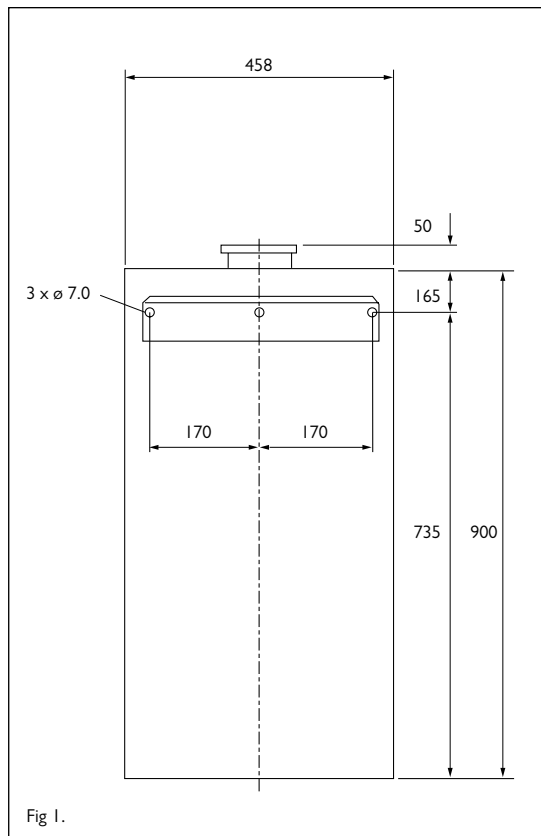

8.0 gas connection

The gas connection is located at the base of the appliance rear r/h side, see fig 2.

The pipe size used to supply the appliance must not be smaller than the gas connection size on the appliance.

The connection to the appliance must include a suitable method of disconnection and a gas control cock must be installed adjacent to the appliance for isolation purposes.

The gas pipe used to supply the appliance must not allow a pressure drop of greater than 1m bar from the meter to the appliance.

The nominal inlet working gas pressure measured at the appliance should be 20.0 mbar for Nat Gas (G20) or 37 mbar for LPG (G31).

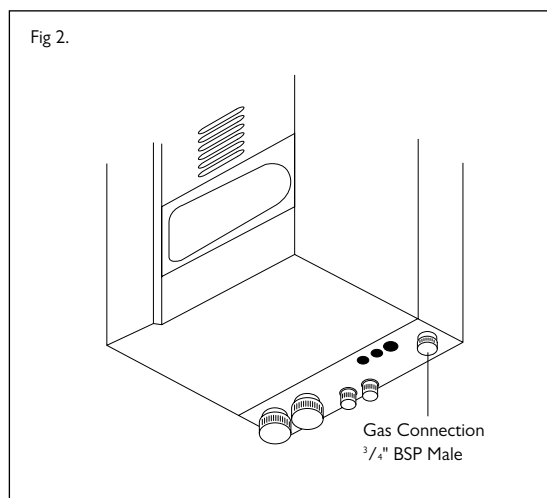

9.0 system flow & return connections

Note The Strata 1 boiler must only be installed on sealed and pressurised systems. The maximum working pressure of the boiler = 3 bar. A safety valve set 3.0 bar is supplied with the boiler and must be installed onto the flow pipe adjacent to the boiler. It is recommended that the final working pressure (hot) of the system does not exceed 2.3 bar.

The boiler is equipped with 2 sets of 1/4" BSP Male flow & return connections which are located top rear L/h side & bottom rear L/h side. See figs 3&4.

The installer may choose to use both top connections or both bottom connections or one of each (e.g. flow-top, return-bottom). The appliance is supplied complete with 2Nr 1/4" x 1/2" BSP reducing sockets (see fig 3. item A) which may be used either at the top of the appliance (when flow and return connections are made to the lower boiler connections) to install air vents or be used at the bottom flow and return connections (when system connecting are to the top of the appliance) to install drain cocks.

The appliance is supplied with 2Nr 1/4" x 1/4" x 1/2" BSP Tees (see fig 4. item B) which may be used to connect the supplied safety valve into the flow pipe adjacent to the appliance and either a system filling point/expansion vessel or a draincock.

The flow and return pipework should include isolation valves and a method of disconnection local to the boiler.

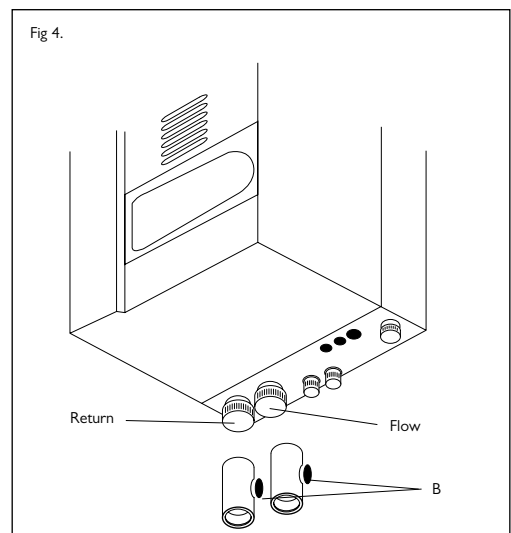
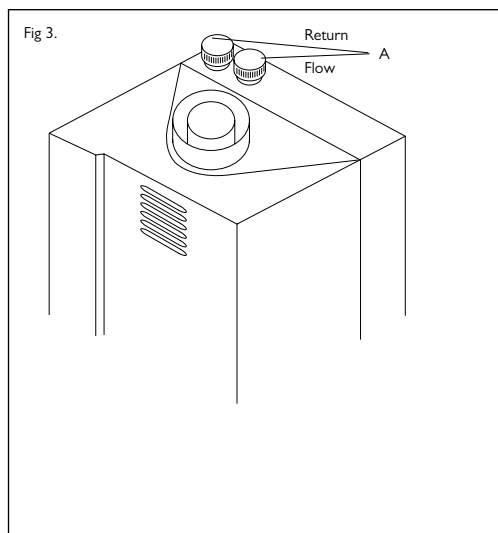

10.0 condense waste connection

The condense waste connection is located at the underside rear of the appliance see fig 5.

The condense syphon cleaning point is factory fitted with a heavy grade black plastic cap which **MUST NOT BE REMOVED** (see fig 5) apart from routine maintenance cleaning operations and must be in place whenever the appliance is in operation. **WARNING** operating the appliance with the cap removed from the syphon cleaning point will cause products of combustion to be discharged from the cleaning point.

The condense waste connection is a 3/4" BSP Male threaded stub fabricated from plastic.

The installer must connect to this stub, a condense waste pipe fabricated from plastic tube and fittings (3/4", 22mm, overflow pipe is considered suitable). Copper Tube is not acceptable. The condense waste pipe must fall continuously from the appliance to suitable nearby drain

10.0 condense waste connection (contd)

If any part of the condense waste pipe is to be run external to the building or is at risk of freezing, then the pipe must be suitably insulated to protect from freezing.

If a suitable drain for accepting the condense waste is not available nearby to, and below the boiler, (e.g. boiler installed in a basement below ground level location), then a suitable condense sump receptacle with a discharge pump should be installed below the boiler to remove the condense to a remote drain.

When making the condense waste pipe connection to the boiler, do not use adhesives, it is recommended to lightly apply a suitable jointing tape (PTFE or similar) and use only light pressure to connect fittings to the appliance to avoid damage to the condense waste outlet assembly.

It is recommended that the condense waste pipework should include a method of disconnection and cleaning points.

11.0 flue/combustion air connection - general

The flue connection and combustion air inlet to the appliance are located on the top of the appliance see fig 6. These connections are arranged concentrically with the 80mm flue gas connection centrally within the 125mm air inlet connection.

There are two options for flueing the Strata 1 boiler.

i) Conventionally, using flue gas tube only and air for combustion from the room or compartment in which the appliance is installed. If using a conventional flue arrangement then the room or compartment must be ventilated in accordance with the requirements of BS 6644 or BS5440 as appropriate. For guidance on ventilation see section 16.

ii) Room sealed using concentric 80/125 components where air for combustion is taken from outside of the building. When using a room sealed flue, whereas air for combustion is provided from outside of the building directly to the appliance, ventilation to a compartment may still be required - See section 16 for general space cooling.

Multiple Boilers

For detail and advice on common flues serving multiple boilers, contact MHS Boilers Ltd.

Important Note

Where the Strata 1 is to be installed in an application where the combustion air is likely to be contaminated with oxidising agents, such as swimming pool areas, special industrial processes etc, then the appliance must be room sealed.

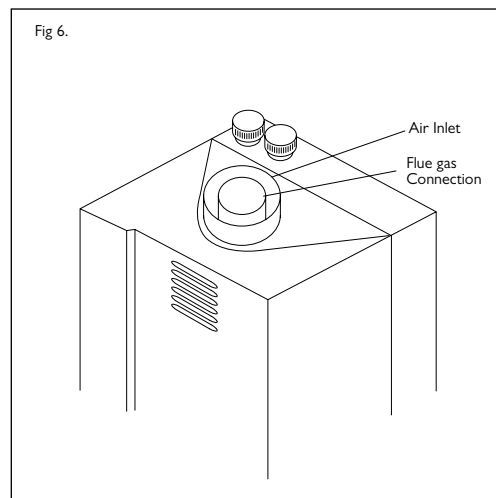
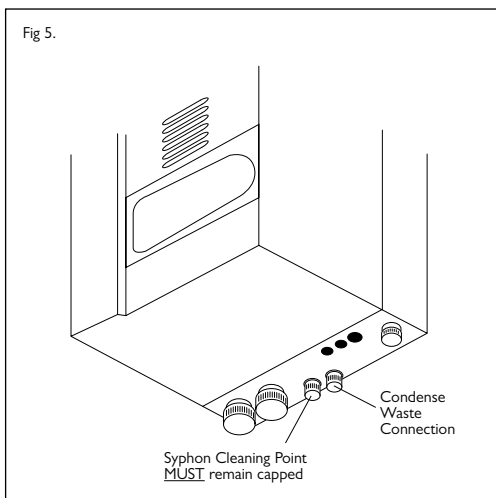

12.0 conventional flue installation

The Strata 1 boiler has an excess pressure combustion system, which coupled with the very low flue gas temperatures produced allows the appliance to exhausted over considerable distances using 80mm Polypropylene PPS flue pipe and fittings. Suitable flue pipe and fittings are available from MHS Boilers Ltd and are listed below.

The flue should be installed to have at least a slight fall to the boiler to allow any condense formed in the flue to run back to the boiler.

The flue system used must be gas and water tight and must be adequately supported over it's entire length. Support at 1 metre intervals. It is not necessary to install a terminal to the flue system, however, a mesh guard should be included to prevent blockage or entry of foreign material. Straight lengths may be cut to size with any surplus cut from the plain end. Tube ends should be cut square and de-burred.

Care should be taken when selecting a position for a low level discharge or discharge adjacent to windows etc as the flue terminal will plume heavily and the white water vapour discharge may cause a visual nuisance.

Flue components available from MHS Boilers Ltd.

80 mm PPS Flue Tube x 1000 mm long (effective length 945 mm)	100 mm PPS Flue Tube x 1000 Long (Effective Length 945 mm)
80 mm PPS Flue Bend x 90°	100 mm PPS Flue Bend x 90°
80 mm PPS Flue Bend x 45°	100 mm PPS Flue Bend x 45°
80 mm Wall Fixing Bracket - Aluminium	100 mm Wall Fixing Bracket
80 mm Bird Mesh Cap - Plated Steel	100 mm Bird Mesh Cap - Plated Steel
	80 x 100 mm Increaser

The above flue components are light grey self coloured Polypropylene moulded components with push together spigot and socket joints with integral seal ring located in the socket.

If fire stop seals are required to be installed where PPS plastic flue components pass through walls, floors or ceilings then suitable fire stop seals are available from:-

Nullfire Ltd
Torrington Avenue
Coventry CV4 9TJ
Tel 01203 855000
Fax 01203 469547

Dufaylite
Developments Ltd
Cromwell Road, St Neots
Huntingdon PE19 1QW

Tel 01480 215000
Fax 01480 405526

Quelfire
PO Box 35, Altrincham
Cheshire WA14 5QA

Tel 0161 928 7308

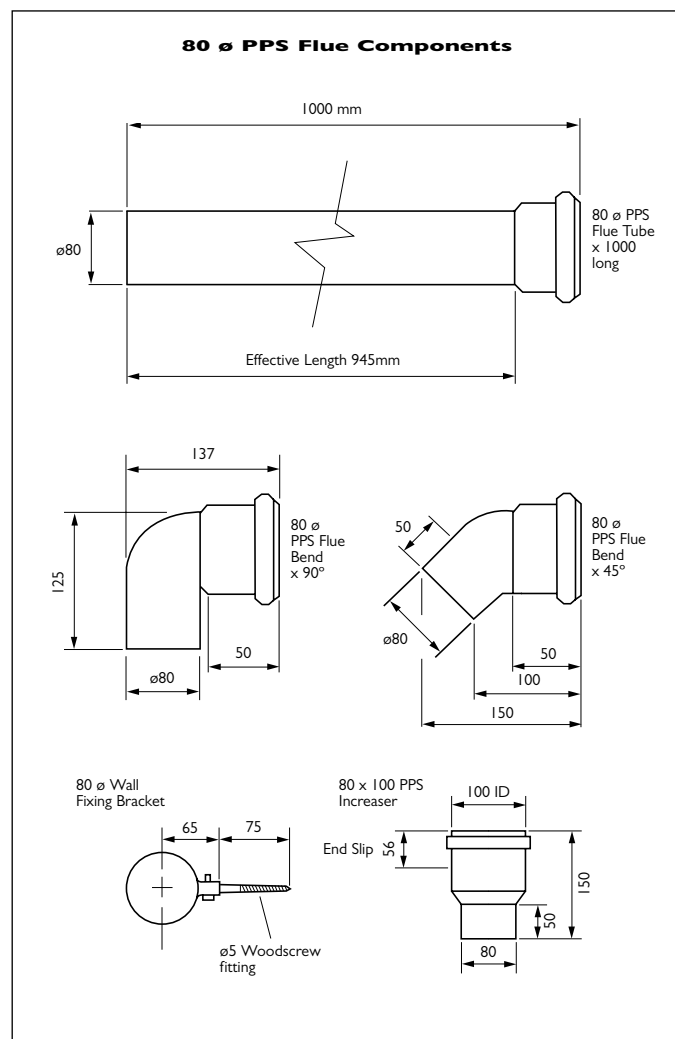

13.0 room sealed *flue installations*

The Strata 1 boiler has an excess pressure combustion system, which coupled with the very low flue gas temperatures produced allows the appliance to be exhausted and supplied with room sealed combustion air using a concentric flue arrangement of 80 mm PPS polypropylene flue pipe within a 125 mm outer painted metal air tube over considerable distances. A range of concentric flue components are available from MHS Boilers Ltd and are listed below.

The concentric flue system should be installed to have at least a 3° fall to the boiler to allow any condense formed in the flue to run back to the boiler.

The flue system must be gas and water tight and must be adequately supported over its entire length. Support at 1.5m intervals. Horizontal Discharge and Vertical Discharge Terminal Sets are available.

Care should be taken when selecting a position for a low level discharge or discharge adjacent to windows etc as the flue terminal will plume heavily and the white water vapour discharge may cause a visual nuisance.

Concentric flue components have push together spigot and socket joints. The inner PPS flue gas tube has seal rings located in the socket component. The outer air tube has EPDM rubber seal rings located in the socket component.

To aid assembly and assurance that the joints have been fully pushed home, the seal rings and make ends of tubes/fittings should be lightly lubricated with silicone grease.

list of concentric flue components

- 80/125 Concentric wall terminal set:- comprises 500 mm (845 mm*) straight length with made on terminal, 90° concentric bend and wall bezel plates.
- 80/125 Concentric roof terminal set:- comprises 1000 mm straight length with made on terminal and 1Nr 125 wall bracket.
- 125 pitched roof tile flashing for use with concentric roof terminal set, adjustable between 25° to 50°.
- 125 flat roof flashing for use with concentric roof terminal set.
- 80/125 Concentric flue tube set x 1000 mm.
- 80/125 Concentric flue tube set x 500 mm.
- 80/125 Concentric 93° Bend.
- 80/125 Concentric 45° Bend.
- 125 Wall bracket assembly.
- 80/125 Concentric Vertically Extendable Discharge Room Sealed Wall Terminal Assembly - For use where a standard wall terminal may cause visual flue gas pluming nuisance. Includes 90° Concentric bend, wall bezel plates and silicone mastic. Used in conjunction with additional 80 mm pps flue gas tube and fittings listed on page 10.
- 80/125 Concentric to 2 x 80 mm Separate Tubes Adaptor.
- 80/125 to 100/150 Concentric Increaser (Not Shown).
- 100/150 Concentric Wall Terminal (Not Shown).
- 100/150 Concentric Roof Terminal (Not Shown).
- 100/150 Concentric Flue Tube Set x 1000 mm (Not Shown).
- 100/150 Concentric Flue Tube Set x 500 mm (Not Shown).
- 100/150 Concentric 93°C Bend (Not Shown).
- 100/150 Concentric 45°C Bend (Not Shown).

* From 01/08/99

STRATA 1

13.0 room sealed flue installations (contd)

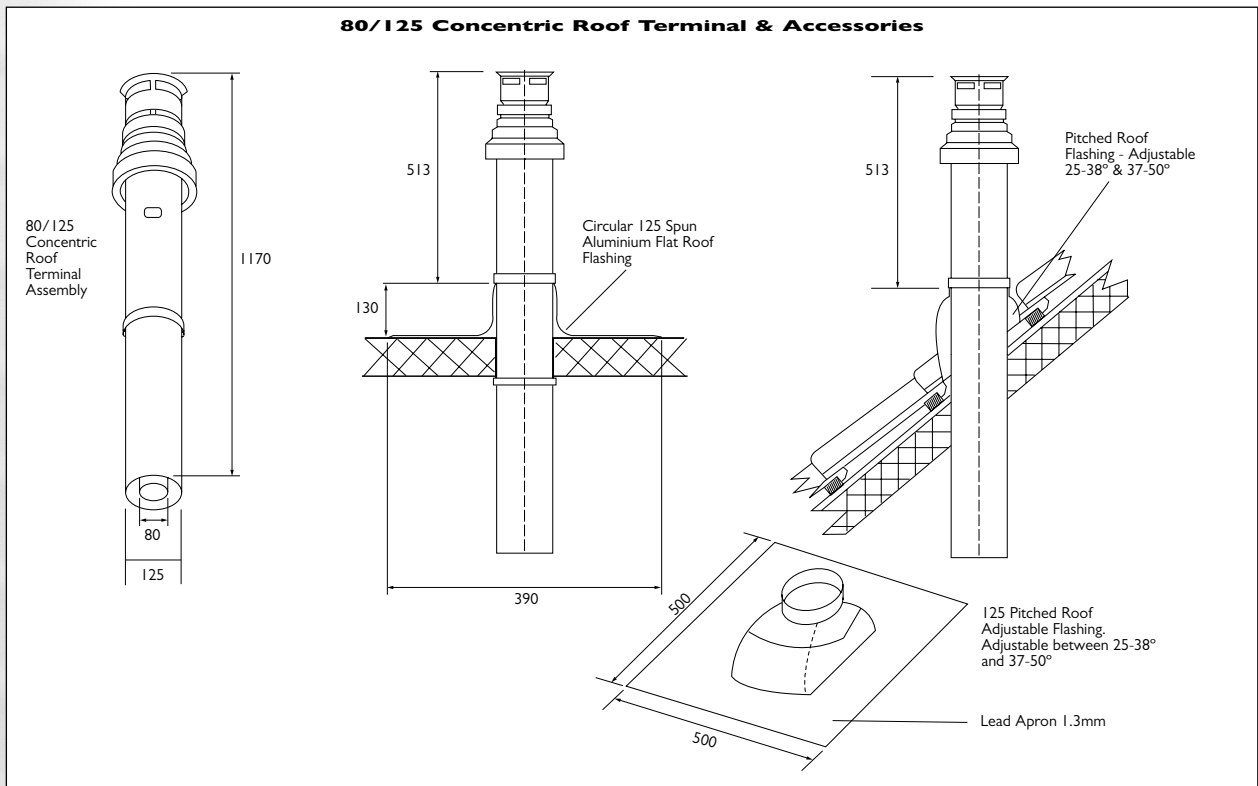
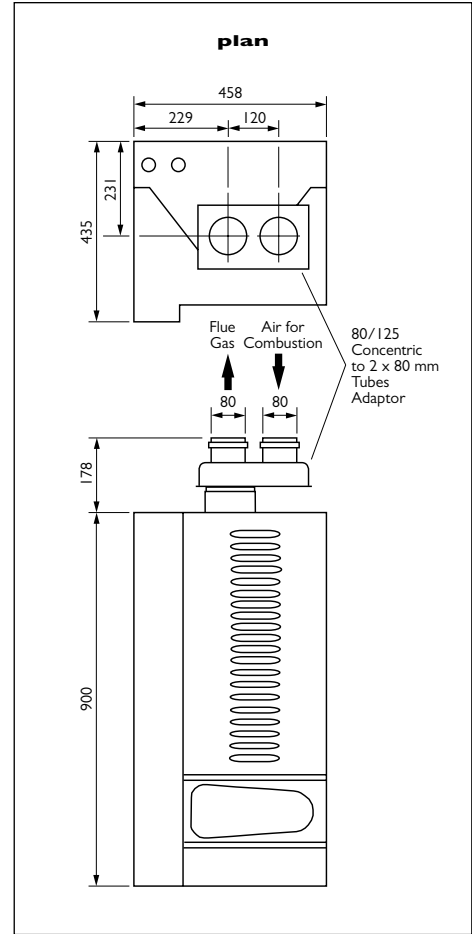
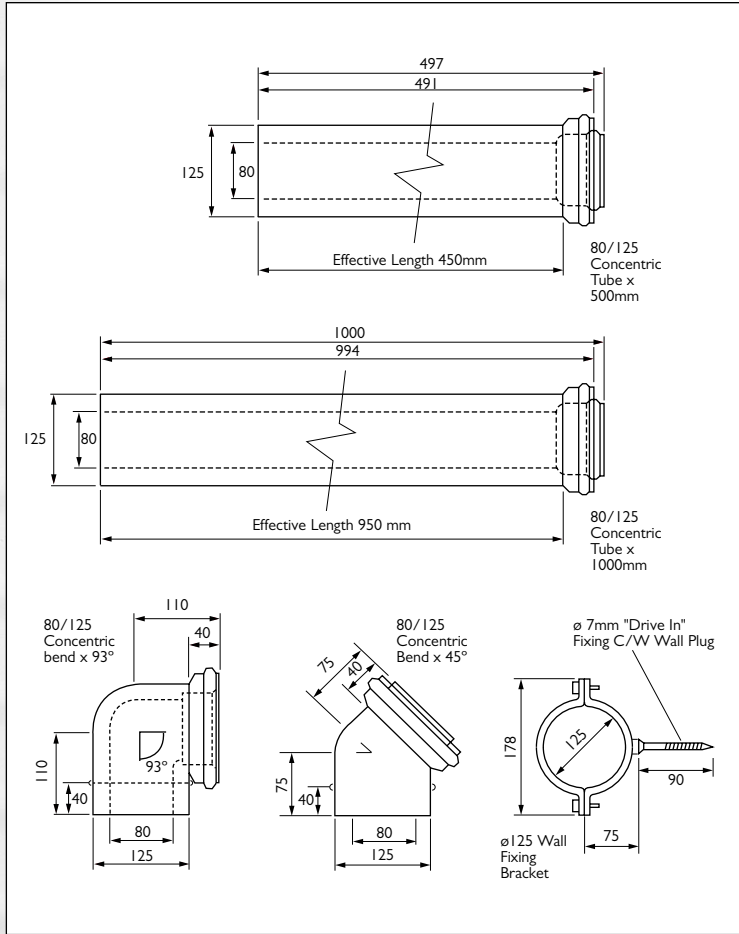

13.0 room sealed flue installations (contd)

Concentric Wall Terminals

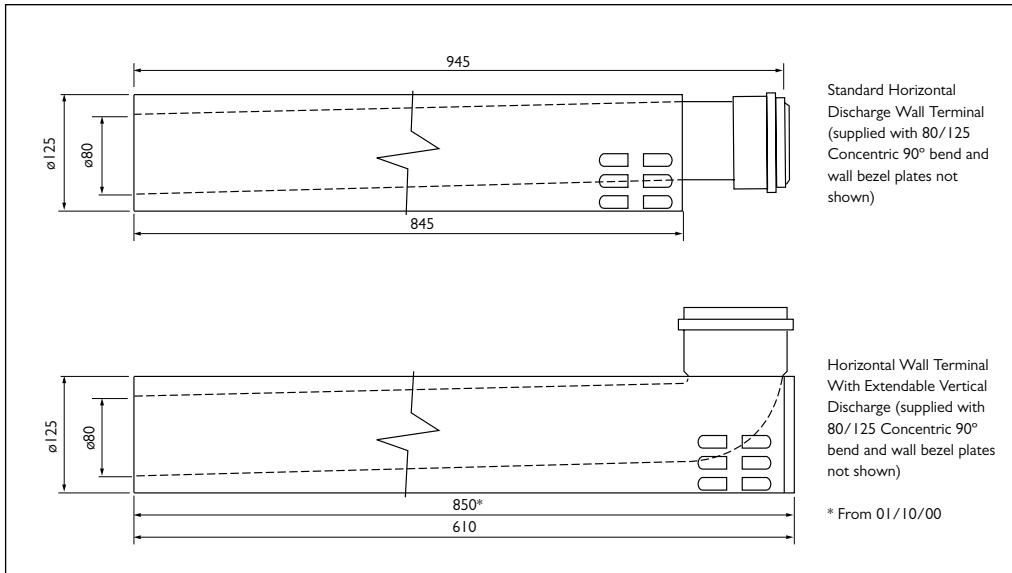

Installation of Standard Wall Terminal

In order to determine the length of concentric tube required to correctly terminate a side outlet arrangement, the following procedure should be followed:

1. Measure wall thickness W in mm - see fig 7.
2. Measure distance between side of appliance and inside face of wall $L1$ in mm see fig 7.
3. Mark off and cut flue tubes following guidance show in fig 8 below. Flue tubes should be cut to length TL in mm. Both inner and outer tubes should be cut flush with each other, square and any burrs removed.

Where TL required, is greater than 845 mm, then additional lengths (as appropriate) of 80/125 concentric tube will be required to extend the standard wall terminal.

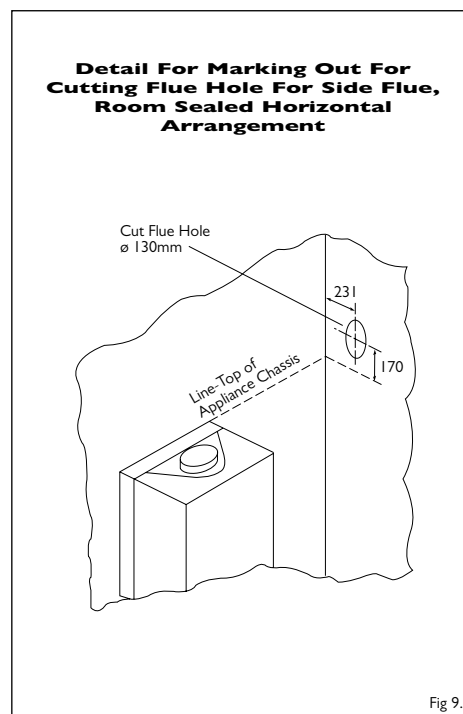
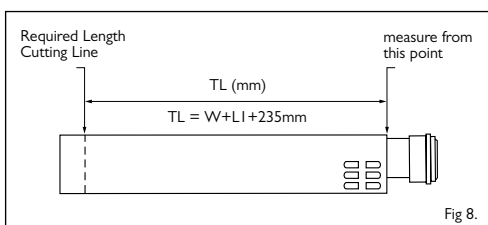
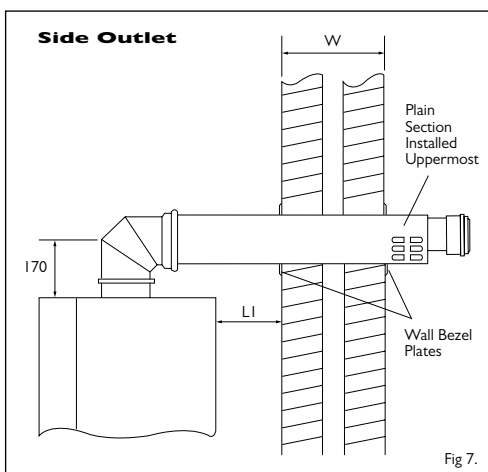

13.0 room sealed flue installations (contd)

Installation of Standard Wall Terminal

In order to determine the length of concentric tube required to correctly terminate a rear outlet arrangement, the following procedure should be followed.

1. Measure wall thickness W in mm - see fig 10.
2. Mark off and cut flue tubes following guidance shown in fig 11 below.

Flue tubes should be cut to length TL in mm. Both inner and outer tubes should be cut flush with each other, square and any burrs removed.

Where TL required, is greater than 845 mm, then additional lengths (as appropriate) of 80/125 concentric tube will be required to extend the standard wall terminal.

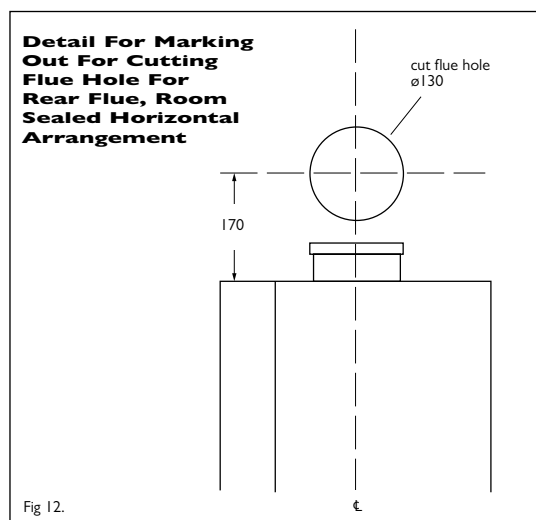
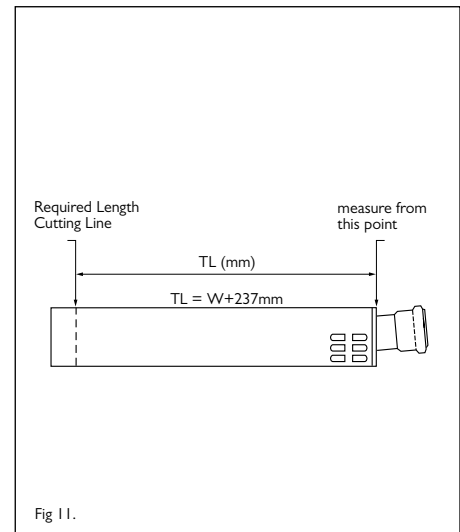
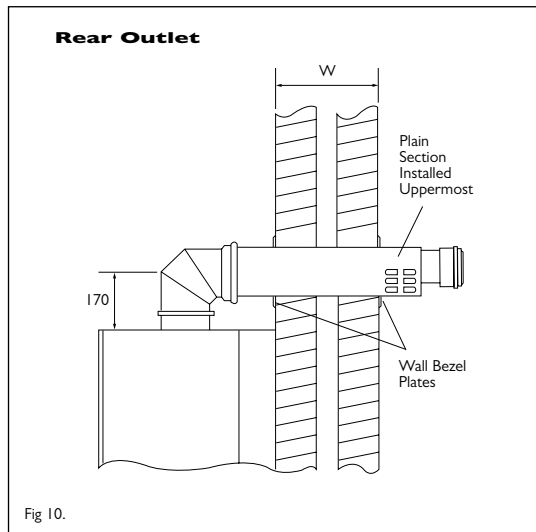

13.0 room sealed flue installations (contd)

Method of assembly of horizontal concentric flue system using standard wall terminal.

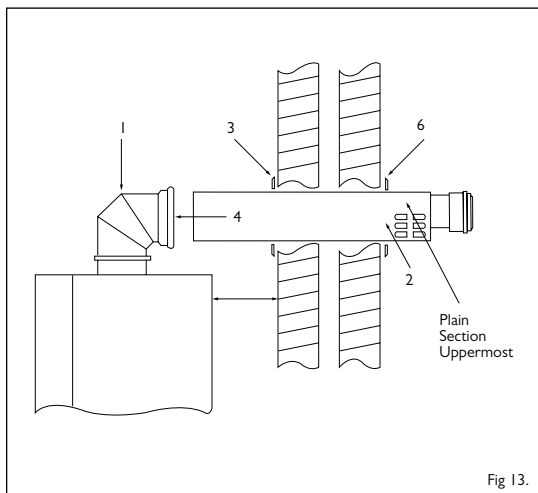

1. Lubricate male ends of concentric bend with silicone grease and locate bend into flue and air tube connection sockets on the top of the boiler and gently push fully home.
2. Slip flue tube and terminal assembly through prepared hole in the outside wall.
3. Locate wall bezel plate loosely onto air tube.
4. Lubricate male ends of concentric flue tube and female sockets of flue bend lightly with silicone grease. Insert concentric tubes into bend and gently push fully home. Ensure plain section of external part of air inlet tube is located uppermost.

5. Make good internally and externally gap between air tube and prepared hole through wall.
6. Slip on external wall bezel plate.
7. Fix internal and external wall bezel plates with fixings provided.

Where a flue terminal discharges through a wall within 2m of ground level or balcony etc then the terminal should be fitted with an appropriate sized terminal guard to prevent that the terminal may be touched.

Extending the flue gas discharge vertically away from a room sealed wall terminal.

The Strata 1 boiler is a fully condensing appliance with very low flue gas temperatures.

Consequently, the flue gas discharge is commonly seen as a white vapour plume, Whereas this is not harmful when properly discharged into the atmosphere outside of a building from a correctly operating appliance, the white vapour plume may cause, in certain applications a visual nuisance.

It must also be considered that a flue termination will drip condense water and may cause an ice hazard below the terminal position

If it is considered that plumbing or dripping from the end of a standard wall terminal may create a nuisance, then as an alternative, the vertically extendable discharge wall terminal is available see figs 14 and 16. This creates a local room sealed intake for combustion air but allows the installer to extend the 80 mm PPS flue gas tube to a point where plumbing or dripping discharge will not cause a visual nuisance or hazard.

Installation of Vertical Discharge Wall Terminal

In order to determine the length of concentric tube required to correctly terminate a side outlet extended vertical discharge arrangement, the following procedure should be followed.

1. Measure wall thickness W in mm - see fig 14 overleaf.
2. Measure distance between side of appliance and inside face of wall $L1$ in mm - see fig 14 overleaf.
3. Mark off and cut flue tubes following guidance shown in fig 15 overleaf. Flue tubes should be cut to length TL in mm. Both inner and outer tubes should be cut flush with each other, square and any burrs removed.

Where TL required, is greater than 610 mm, (*850mm) then additional lengths (as appropriate) of 80/125 concentric tube will be required to extend the vertical discharge wall terminal.

Installation of Vertical Discharge Wall Terminal With Side Outlet

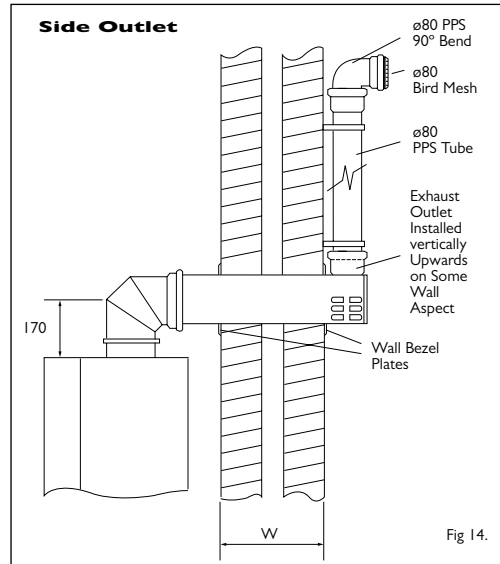

Fig 14.

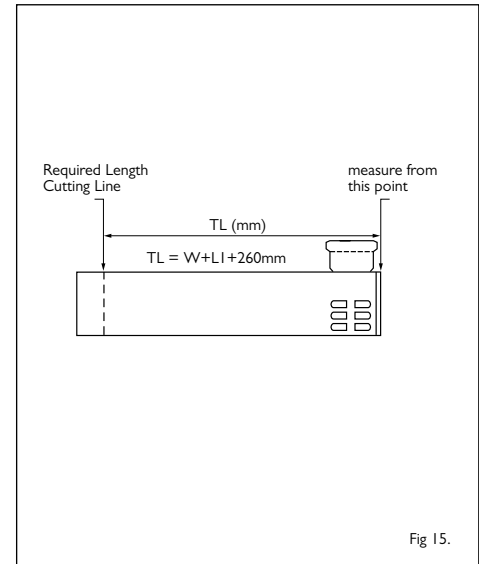

Fig 15.

Installation of Vertical Discharge Wall Terminal With Rear Outlet

In order to determine the length of concentric tube required to correctly terminate a rear outlet extended vertical discharge arrangement, the following procedure should be followed.

1. Measure wall thickness W in mm - see fig 16.
2. Mark off and cut flue tubes following guidance shown in fig 17 below.

Flue tubes should be cut to length TL in mm. Both inner and outer tubes should be cut flush with each other, square and any burrs removed.

Where TL required is greater than 610 mm, (*850mm) then additional lengths (as appropriate) of 80/125 Concentric tube will be required to extend the vertical discharge wall terminal.

* available 01/10/00

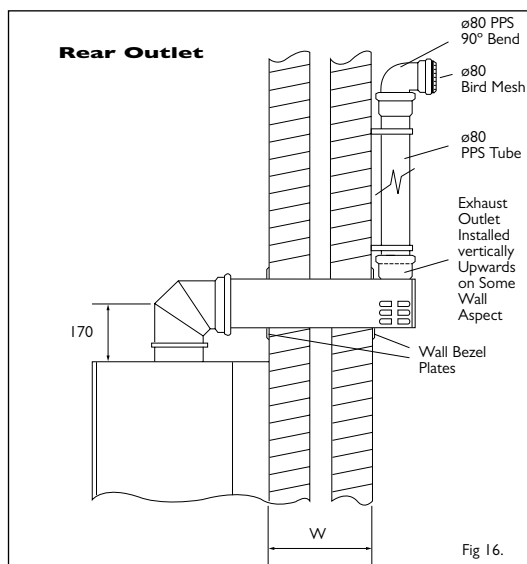

Fig 16.

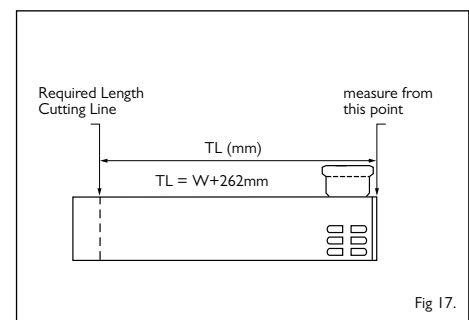
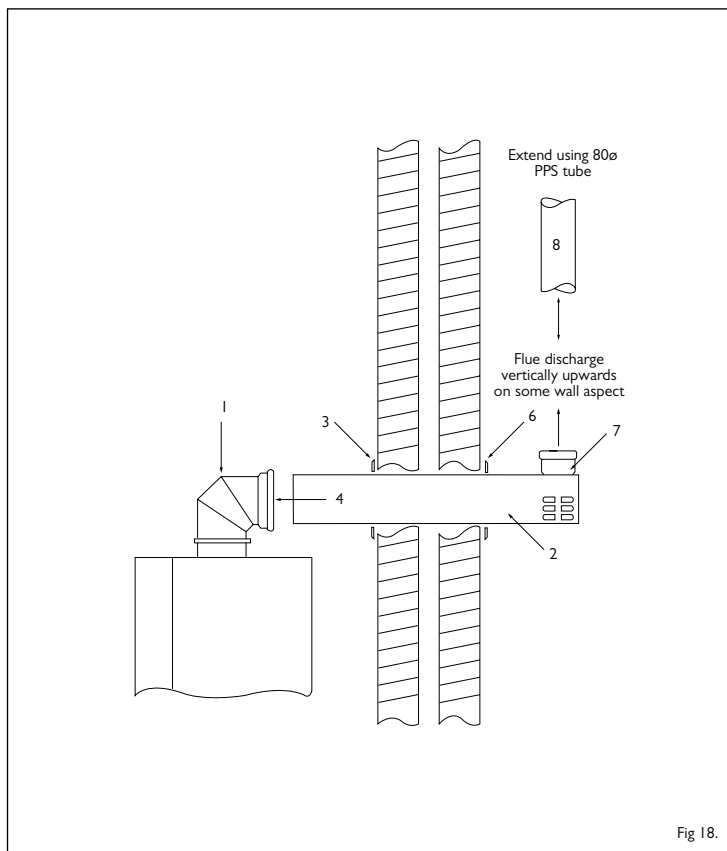

Fig 17.

Method of assembly of extendable vertical discharge wall terminal assembly.

See fig. 18

1. Lubricate male ends of concentric bend with silicone grease and locate bend into flue and air tube connection sockets on the top of the boiler and gently push fully home.
2. Slip flue tube and terminal assembly through prepared hole in the outside wall.
3. Locate internal wall bezel plate loosely onto air tube.
4. Lubricate male ends of concentric flue tubes and female sockets of flue bend lightly with silicone grease. Insert concentric tubes into bend and gently push fully home. Ensure flue gas discharge is positioned vertically upwards.
5. Make good internally and externally gap between air tube and prepared hole through wall.
6. Fit external 2 piece wall bezel and secure both internal and external wall bezels using fixings provided.
7. Seal air tube to exhaust discharge with a bead of silicone rubber mastic (mastic supplied) to create weather seal to avoid entry of rain water into air tube.
8. Extend flue gas discharge to chosen position using 80 mm PPS flue tube fittings.



14.0 examples of calculating flue pressure loss

example 1

A Strata 1-60 boiler is installed with a concentric flue system which takes an all horizontal route to a wall terminal. Length of flue = 3m including one 90° bend.

Resistance =
 3 x 1m length 80/125 concentric tube @ 8.5 Pa = 25.5
 1 x 90° 80/125 concentric bend @ 8.5 Pa = 8.5
 1 x 80/125 concentric wall terminal @ 11.0 Pa = 11.0

Total Resistance = 45 Pa

conclusion: Total resistance is less than 100 Pa, therefore, no alternative design required and no effect on boiler output, or positioning required.

example 2

A Strata 1-45 boiler is installed with a concentric flue system which takes a part horizontal, part vertical route to a roof terminal with rain cap.

Length of horizontal section = 3m, vertical section = 12m, system includes 3x90° bends.

Resistance =
 15 x 1m lengths 80/125 concentric tube @ 5.5 Pa = 82.5
 3 x 90° 80/125 concentric bend @ 5.5 Pa = 16.5
 1 x 80/125 roof terminal @ 11.25 Pa = 11.25

Total Resistance = 110.25 Pa

Take into account that 12m of vertical (assume un-insulated, as air for combustion direct from outside air surrounds the flue gas tube) flue creates 20 Pa of up-draught, then final resistance = 110.25 - 20 = 90.25 Pa.

conclusion: Final operating resistance is less than 100 Pa, therefore, no alternative design required and no effect on boiler output.

example 3

A Strata 1-75 boiler is installed (non room sealed) with a proposed flue using DN 80 PPS single skin flue components which takes a part horizontal, part vertical route to a vertical open termination with bird mesh.

Length of horizontal section = 4m, length of vertical (un-insulated) section = 11m with 4 x 90° bends, and 2 x 45° bends.

Resistance =
 15 x 1m lengths DN 80 PPS tube @ 8.0 Pa = 120
 4 x 90° DN 80 PPS bends @ 8.0 Pa = 32
 2 x 45° DN 80 bends @ 4.0 Pa = 8.0
 1 x DN 80 open termination @ 8.0 Pa = 8.0

Total Resistance: 168 Pa

Take into account that 11m of vertical un-insulated flue creates 18 Pa of up-draught, then final resistance would be 168 - 18 = 150 Pa.

Reference to the graph of resistance effect on boiler output shows the output would be reduced to approximately 67kW. If this is unacceptable, then the flue resistance must be re-calculated using a larger size flue tube as shown below or consideration given to moving the boiler position.

Re-calculating proposed flue installation using DN100.
 15 x 1m lengths DN 100 PPS tube @ 3.0 Pa = 45
 4 x 90° DN 100 bends @ 3.0 Pa = 12
 2 x 45° DN 100 bends @ 1.5 Pa = 3.0
 1 x DN 100 open termination @ 4.0 Pa = 4.0

Total Resistance: 64 Pa

Take into account thermal up-draught created (as before) 18 Pa. Therefore, operating resistance = 64 - 18 = 46 Pa, with no effect on boiler output.

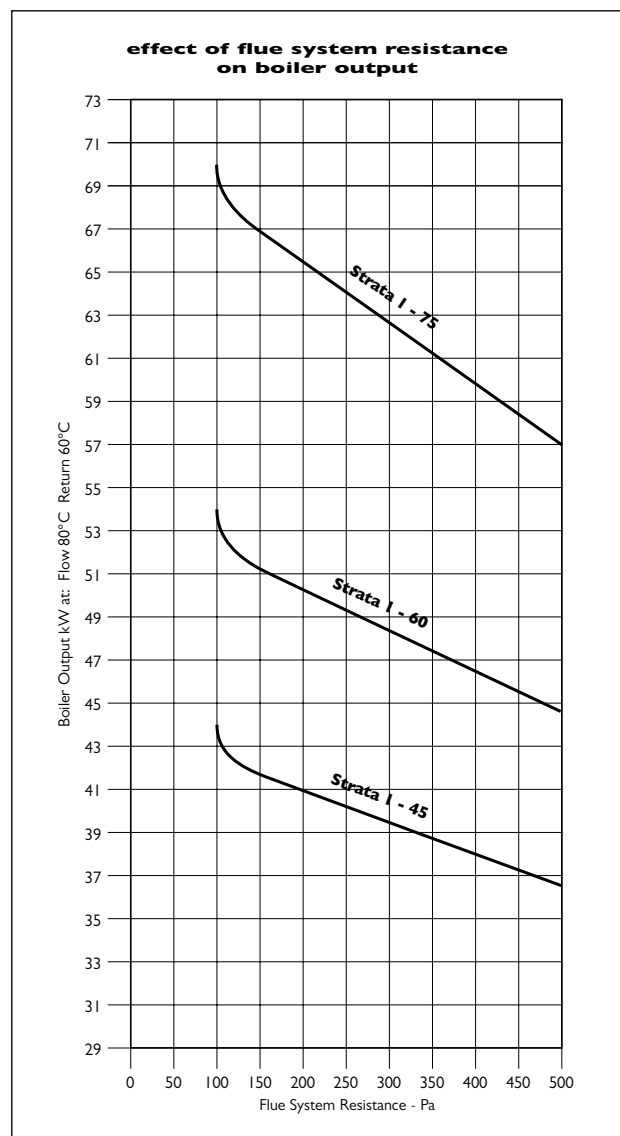
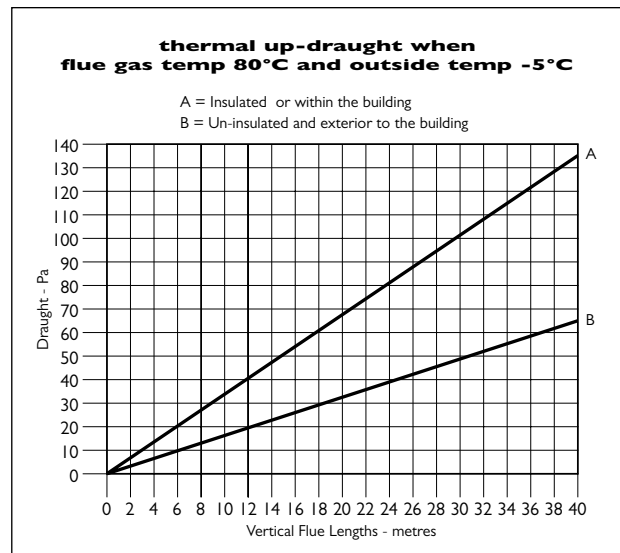

14.0 calculating flue resistance

The excess pressure available for overcoming the frictional resistance of a flue system is 100 Pa.

The adjacent table of flue component resistances will assist the designer in calculating total flue system frictional loss.

If the total installed flue system resistance exceeds 100 Pa., then the result will be a reduction in boiler output. Reference to the "Effect of Flue System Resistance On Boiler Output", graphs will assist. If the resistance of a proposed flue system has an unacceptable effect on boiler output, then a larger diameter flue tube should be selected.

Thermal up-draught is generated in a vertical flue system, reducing the resistance of the system. Reference to the "Thermal Up-draught Graph" will provide a figure in Pa., which may be deducted from the total calculated flue system resistance.

NB. Thermal updraught does not apply to horizontal sections of a flue system.

Component Resistance Pa.	Boiler Model		
	45	60	75
80/125 Concentric Wall Terminal	7.5	11.0	16.0
80/125 Concentric Roof Terminal Without Rain Cap	7.5	11.0	16.0
80/125 Concentric Roof Terminal With Rain Cap	11.25	16.5	24.0
1m length 80/125 Concentric Tube	5.5	8.5	12.0
93° 80/125 Concentric Bend	5.5	8.5	12.0
45° 80/125 Concentric Bend	2.75	4.25	6.0
80/125 Concentric To 2 x 80 Tubes Adaptor	4.0	6.0	10.0
1m length DN 80 PPS Tube Carrying Fluegas	5.0	7.5	11.0
1m length DN 80 PPS Tube Carrying Combustion Air	3.0	5.0	7.0
90° DN 80 PPS Bend Carrying Fluegas	5	7.5	11.0
90° DN 80 PPS Bend Carrying Combustion Air	3.0	5.0	7.0
45° DN 80 PPS Bend Carrying Fluegas	2.5	4.0	5.5
45° DN 80 PPS Bend Carrying Combustion Air	1.5	2.5	3.5
Room Sealed Chimney Cap DN 80	7.0	10.0	15.0
DN 80 x 100 PPS Increaser Piece-Fluegas or Air	1.0	1.0	1.0
90° DN 100 PPS Bend Carrying Fluegas	2.0	2.5	4.0
90° DN 100 PPS Bend Carrying Combustion Air	1.5	2.0	2.0
45° DN 100 PPS Bend Carrying Fluegas	1.0	1.3	2.0
45° DN 100 PPS Bend Carrying Combustion Air	0.8	1.0	1.0
1m length DN 100 PPS Tube Carrying Fluegas	2.0	2.5	4.0
1m length DN 100 PPS Tube Carrying Combustion Air	1.5	2.0	2.0
DN 80 Open Termination With Mesh	4.0	5.5	8.0
DN 100 Open Termination with Mesh	2.0	3.0	4.0
80/125 Concentric Wall Terminal With Vertical Discharge	7.5	11.0	16.0
80/125 To 100/150 Concentric Increaser	2.0	3.0	5.0
100/150 Concentric Wall Terminal	3.0	4.0	7.0
100/150 Concentric Roof Terminal	3.0	4.0	7.0
1m length 100/150 Concentric Tube	2.0	3.0	5.0
93° 100/150 Concentric Bend	2.0	3.0	5.0
45° 100/150 Concentric Bend	2.0	2.0	3.0

15.0 flue terminal positions

The flue terminal of a Strata 1 boiler will plume heavily and care must be taken when selecting a terminal position to ensure that a "nuisance situation" is not created.

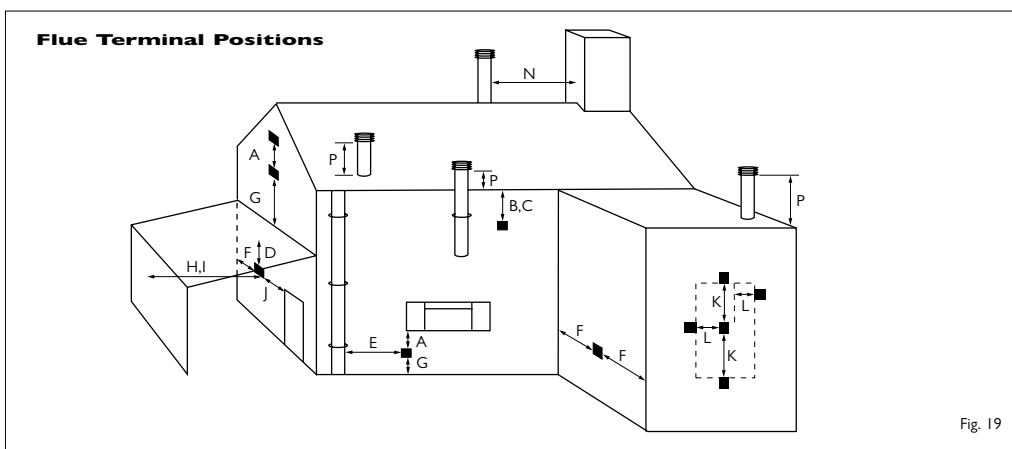

If a flue terminal is positioned within 2 m above ground level or any upper part of a building where people have general access (e.g. balcony etc) then the terminal should be fitted with an appropriate guard.

15.0 flue terminal positions (contd)

Minimum dimensions of flue terminal positions see fig 19

Dimension	Terminal Position	Balanced flue room sealed	Non room sealed
A	Directly below an opening, air brick, windows etc. Not Recommended.	300 mm	300 mm
B	Below gutters, soil pipes or drain pipes	75 mm	75 mm
C	Below eaves	200 mm	200 mm
D	Below balconies or car port roof. Not Recommended.	200 mm but installation not recommended.	200 mm but installation not recommended.
E	From a vertical drain pipe or soil pipe	75 mm	75 mm
F	From an internal or external corner	300 mm	200 mm
G	Above ground, intersecting roof or balcony level	300 mm	300 mm
H	From a surface facing the terminal	2000 mm	2000 mm
I	From a terminal facing the terminal	2000 mm	2000 mm
J	From an opening in the car port (e.g. door, window) into dwelling	1200 mm but installation not recommended.	1200 mm but installation not recommended.
K	Vertically from a terminal on the same wall	1500 mm	1500 mm
L	Horizontally from a terminal on the same wall.	300 mm	300 mm
M	From the wall on which the terminal is mounted.	N/A	50 mm
N	From a vertical structure on the roof	500 mm	N/A
P	Above intersection with roof	500 mm	150 mm

16.0 ventilation requirements *single appliances*

The room or space in which the Strata 1 boiler is installed may require to be ventilated in accordance with BS5440: Part 2: 2000 or BS 6644: 1991 as appropriate to the boiler input.

The following tables must be read to ascertain the amount of ventilation required.

Table 1	Room Installation - <u>Non</u> Room Sealed Flue. Natural Ventilation Direct to Outside Air
Boiler Model	Ventilation Openings Free Area cm ²
Strata 1/45	180 For position see BS 5440: Part 2: 2000
Strata 1/60	250 For position see BS 5440: Part 2: 2000
Strata 1/75	319 High Level 637 Low Level

Table 2	Room Installation - <u>Non</u> Room Sealed Flue Natural Ventilation From Adjacent Room
Boiler Model	Ventilation Openings Free Area cm ²
Strata 1/45	180cm ² with adjacent room equally ventilated direct to outside air.
Strata 1/60	250cm ² with adjacent room equally ventilated direct to outside air.
Strata 1/75	Ventilation from adjacent room not permitted - See Table 1 above.

Table 3	Room Installation - Room Sealed Flue. There are no specific requirements for a room to be ventilated where the appliance is room sealed. However, consideration should be given to providing ventilation for general cooling, (BS6644 specifies room temperature limits).
----------------	----------------------------------------------------------------------------------------------------------------------------------------------------------------------------------------------------------------------------------------------------------------------------------

Table 4	Compartment Installation - Non room sealed flue Natural Ventilation Direct to outside air
Boiler Model	Ventilation Openings Free Area cm ²
	High Level Low Level
Strata 1/45	215 430
Strata 1/60	285 570
Strata 1/75	319 637

Table 5	Compartment Installation - Non room sealed flue Natural Ventilation from Adjacent room
Boiler Model	Ventilation Openings Free Area cm ²
	High Level Low Level
Strata 1/45	430 860 with adjacent room ventilated at 180cm ² direct to outside air.
Strata 1/60	570 1140 With adjacent room ventilated at 250cm ² direct to outside air.
Strata 1/75	Ventilation from adjacent room not permitted - See Table 1 above.

16.0 ventilation requirements single appliances (contd)

Table 6 Compartment Installation - Room sealed flue
Natural Ventilation direct to outside air.

Boiler Model	Ventilation Openings Free Area cm ²	
	High Level	Low Level
Strata 1/45	215	215
Strata 1/60	285	285
Strata 1/75	360	360

Table 7 Compartment Installation - Room Sealed Flue
Natural Ventilation from Adjacent Room

Boiler Model	Ventilation Openings Free Area cm ²	
	High Level	Low Level
Strata 1/45	430	430
Strata 1/60	570	570
Strata 1/75	Ventilation from adjacent room not permitted - See Table I above.	

Multiple Appliances Installed in the Same Room or Space

Where multiple Strata 1 boilers are installed in the same room or space then the aggregate of the appliance inputs must be taken to determine (from the following data) the amount of ventilation required.

Appliance gross heat inputs should be taken as:-

Strata 1/45	= 50.34 kW
Strata 1/60	= 60.20 kW
Strata 1/75	= 81.41 kW

Table 8 Non Room Sealed Flue Installations
Natural Ventilation Direct to Outside Air.

Low Level (Inlet):
540cm² plus 4.5cm² per kW in excess of 60kW total rated input.

High Level (Outlet):
270cm² plus 2.25cm² per kW in excess of 60kW total rated input.

Table. 9 Room Sealed Flue Installations
Natural Ventilation Direct to Outside Air
(Ventilation recommended for cooling purposes)

Low Level (Inlet): 4.5cm² per kW of total rated input.
High Level (Outlet): 4.5cm² per kW of total rated input.

17.0 hydraulic system design

- The Strata 1 boiler can be operated to serve a heating load in a number of ways:
 1. Constant flow temperature, with the option to set either high temperature (85°C), medium temperature (75°C) or low temperature (55°C).
 2. Direct-on-boiler weather compensated flow temperatures, with adjustable maximum flow temperature.
 3. Underfloor heating coils via a VT mixing valve with a maximum flow temperature of 55°C plus a second circuit (eg. radiators) operating with direct-on-boiler weather compensated temperatures.
- Flow to return drop (Δt). The microprocessor controls monitor return temperature and the facility to dictate a set Δt (by pump speed modulation) is a standard and most important feature and will where possible maintain the Δt across the boiler at 20°C, as the lower the return temperature, the higher the operating efficiency. Designing for a Δt 20°C gives the added cost saving advantage of smaller pipe sizes and pumps.
- The Strata 1 includes 'in built' primary pumps with a residual head pressure as listed below.
- Appliances may be installed as single units or in multiples.
- Single units may or may not require additional system pumps which will be dictated by the system configuration and by the index resistance.
- Multiple units (and single units which require additional pumps), should always be installed with a low loss mixing header or similar arrangement. - see table below.
- The Strata 1 boiler has in built domestic hot water (remote stored) temperature control ability, and if required, the in built pumps may be used to provide the primary flow to a nearby indirect cylinder or calorifier with the boiler controlling a diverter valve in the main flow or return pipework.
- BS 6644 Requires that the following devices shall be installed, and provision within the system design must allow for: Low water pressure cut off device, water pressure gauge and a temperature gauge.

low velocity mixing header diameter sizing guide

Boiler Power kW	Design Δt 20°C
Up to 45	40mm
75	50mm
100	65mm
120	65mm
150	80mm
200	80mm
250	100mm
270	100mm
300	100mm
340	100mm

Tube diameters refer to steel pipe and calculated using data from CIBSE Guide C4

in-built boiler pumps approx residual head pressure at max speed

Boiler Model	Pressure Metres wc
45	3.1
60	3.0
75	2.6

The following system schematics show a number of typical installation types to which the Strata 1 boiler may be connected.

The Strata 1 is not limited to just the systems shown, and may be used in conjunction with many commercially available control items.

For further advice or guidance on schematic designs or control options contact MHS Boilers Ltd.

17.0 hydraulic system design

System Type I

Typical single Strata I boiler installation serving heating only where the boiler's own in-built circulating pumps are used to circulate the water around the system (used only where system index resistance < pump residual head - see page 23). Flow temperature may be Fixed/constant or weather variable

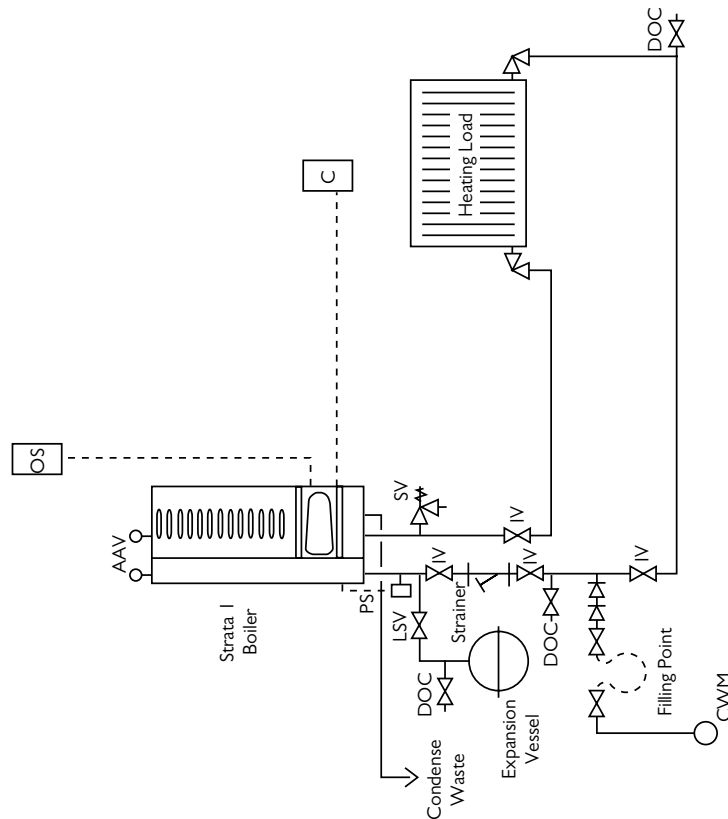

OS= Outside air temperature sensor, used where direct-on-boiler weather compensated flow temperatures are required

C= Room temperature & time controls e.g. RE2132 modulating room unit from MHS Boilers, or, separate time clock & room thermostat

PS= Low water pressure cut off switch.

17.0 hydraulic system design

System Type 2

Typical single Strata 1 boiler installation serving domestic hot water and heating where hotwater has priority via a divertor valve. The in-built circulating pumps within the boiler are used to circulate the system (used only where system index resistance < pump residual head - see page 23). Flow temperature to hotwater is constant and flow temperature to heating may be constant or weather variable.

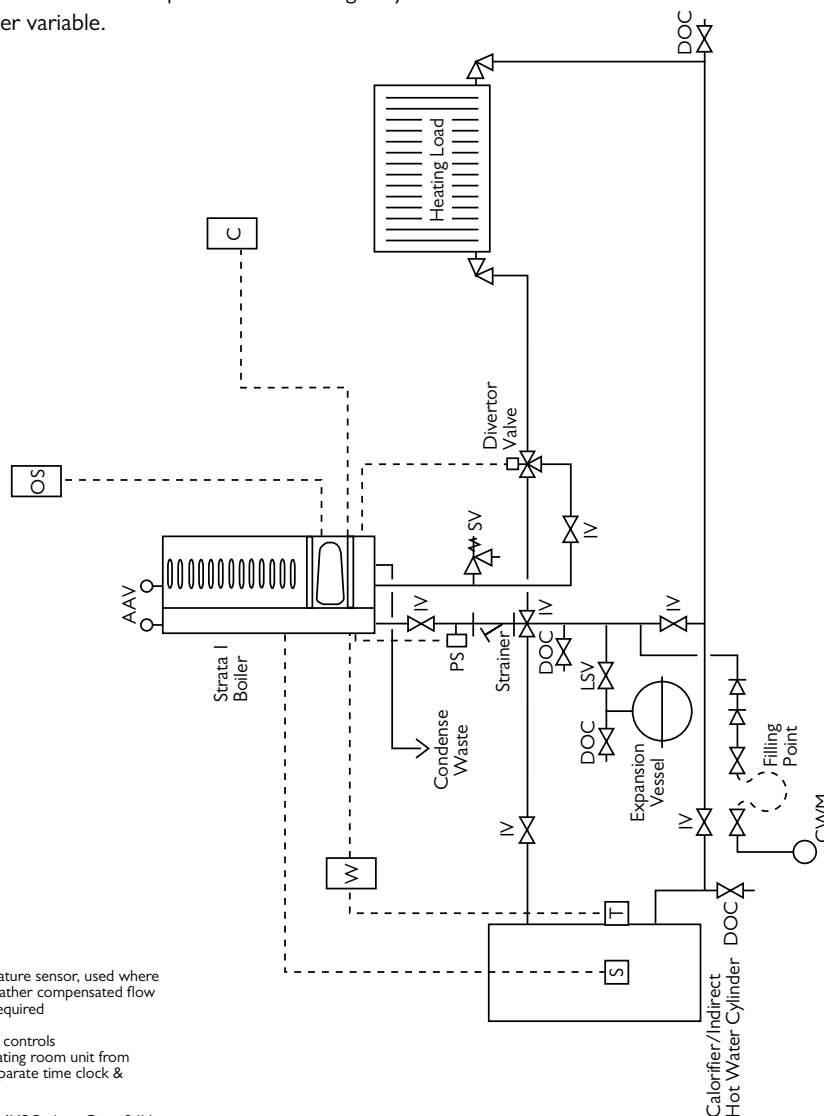

OS= Outside air temperature sensor, used where direct-on-boiler weather compensated flow temperatures are required

C= Room temperature controls e.g. RE2132 modulating room unit from MHS Boilers, or, separate time clock & room thermostat

S= HWS sensor from MHS Boilers. Gives 24Hr HWS operation

W/T= Alternative to "S" where "W" is a time switch in series with a cylinder thermostat "T". Allows for timed HWS.

Divertor valve will require SPDT relay if not spring return.

Divertor valve must be so installed as to spring return to heating.

PS= Low water pressure cut off switch.

17.0 hydraulic system design

System Type 3

Typical Single Strata 1 boiler installation serving heating only and using a low velocity mixing header where system index resistance exceeds in-built boiler pump residual head - see page 23. Flow temperature may be fixed/constant or weather variable.

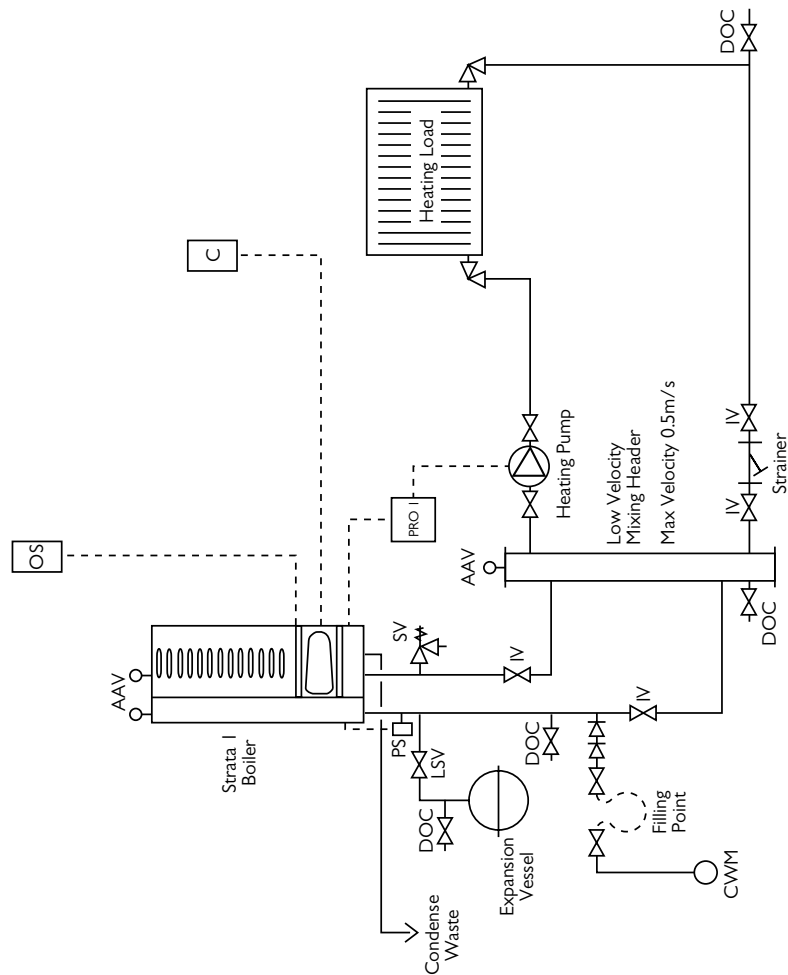

OS= Outside air temperature sensor, used where direct-on-boiler weather compensated flow temperatures are required.

C= Room temperature controls e.g. RE2132 modulating room unit from MHS Boilers, or, separate time clock & room thermostat.

PRO= Pump regulation module from MHS Boilers. Allows heating pump to be driven from boiler, providing for auto operation, frost protection running & summer standstill exercising. **Must be used** where RE2132 modulating room unit is installed. Max pump motor load 2A

PS= Low water pressure cut off switch

17.0 hydraulic system design

System Type 4

Typical Single Strata 1 boiler installation serving heating & domestic hot water. Hot water is priority and is served via a diverter valve and the boiler's in built circulating pump where index loss through HWS primaries is less than boiler pump residual head*. Heating circuit index loss exceeds boiler pump residual head* and is served via a low velocity mixing header and a separate pump. Heating flow temperature may be fixed/constant or weather variable.

* See page 23

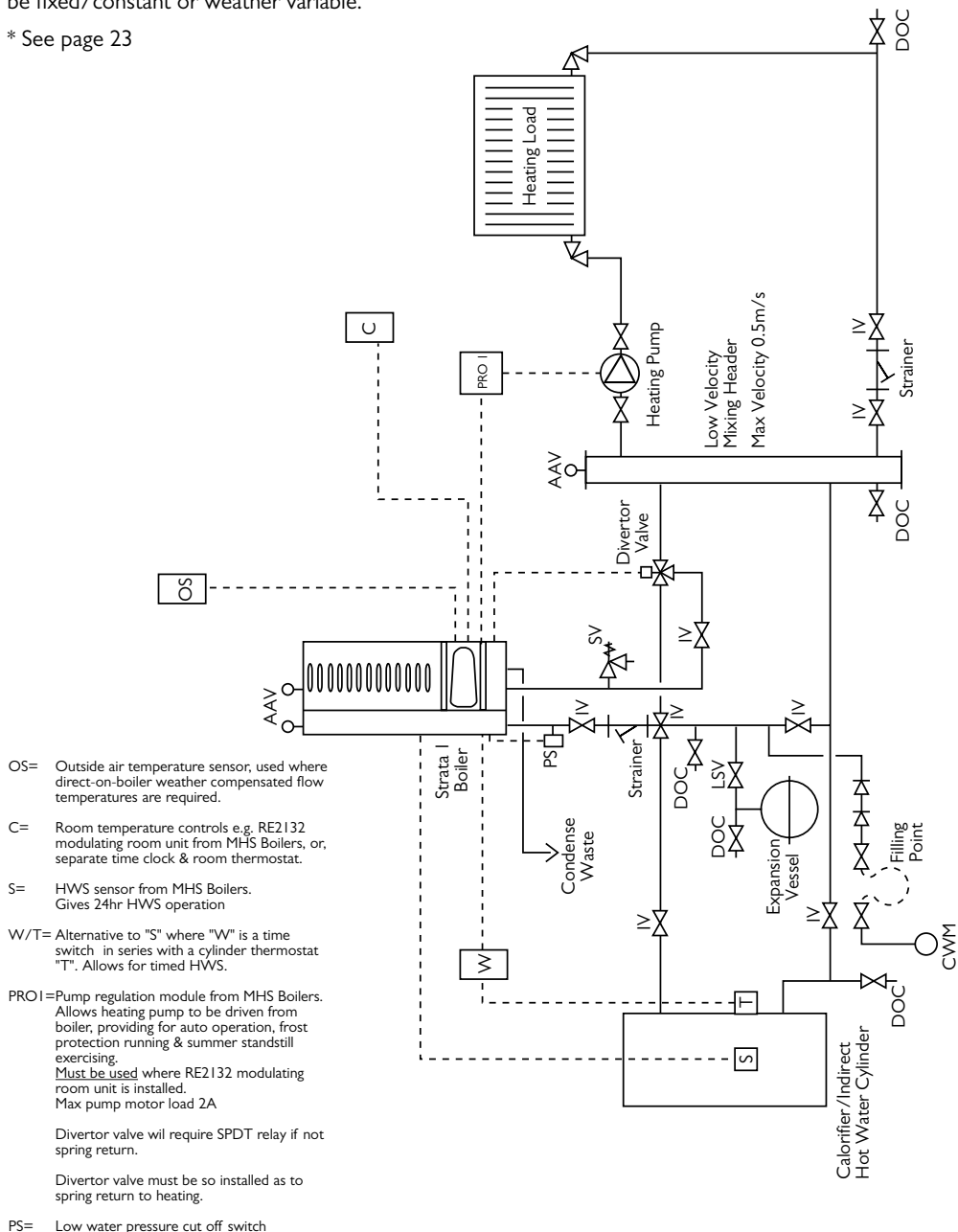

17.0 hydraulic system design

System Type 5

Typical Single Strata 1 boiler installation serving heating & domestic hot water with hot water priority. Hotwater & heating circuits both have index resistance exceeding boiler pump residual head* & are served by independent pumps from a low velocity mixing header. Heating flow temperature may be fixed/constant or weather variable.

* See page 23

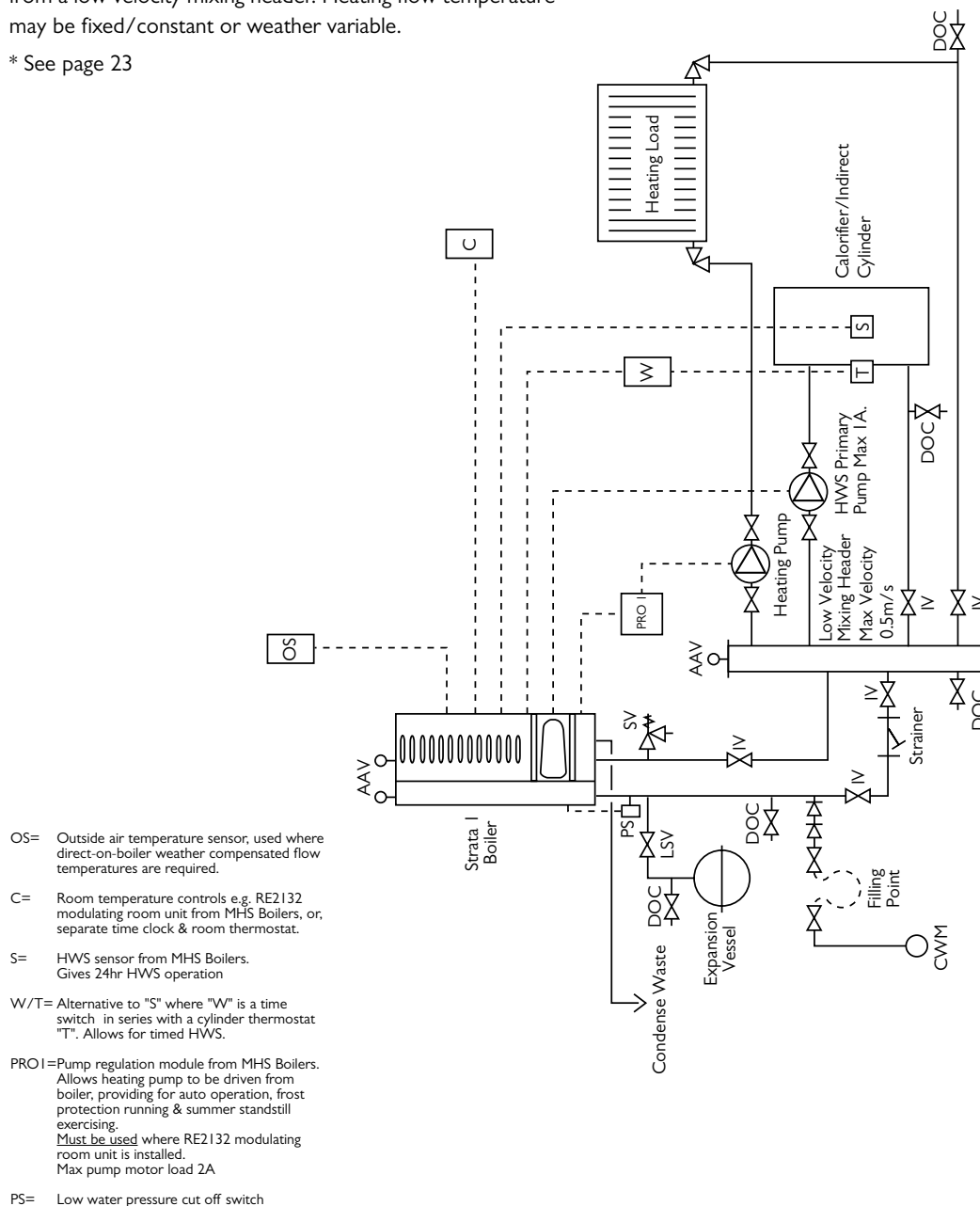

STRATA 1

17.0 hydraulic system design

System Type 7

Typical Single Strata 1 boiler installation serving domestic hotwater and radiator heating zone and an underfloor coil zone all via a low velocity mixing header. The HWS will always have priority. the 2Nr heating zones may operate independently via 2 Nr separate room units. The 2 Nr heating zones will always be weather compensated but may have differing compensation slopes

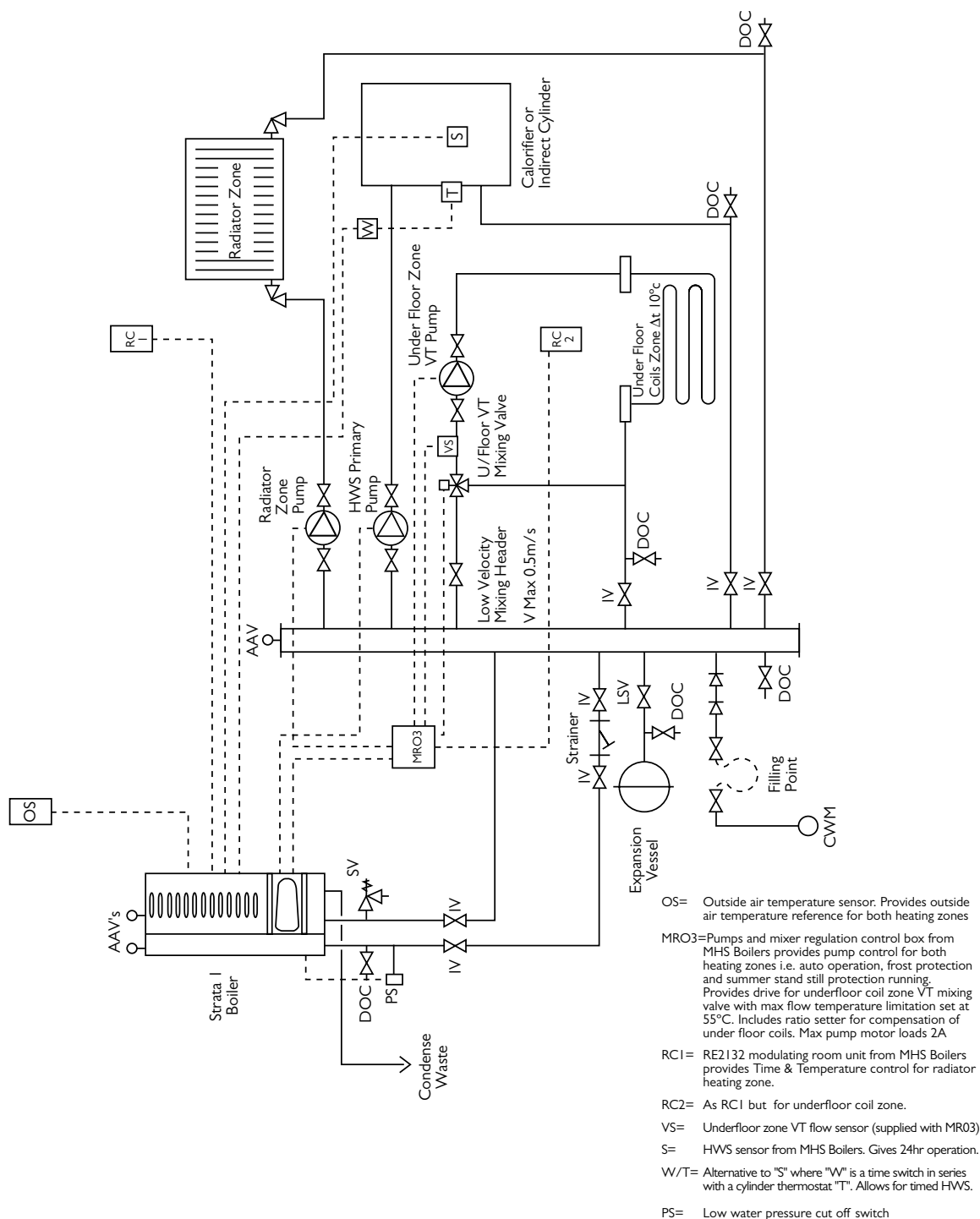

17.0 hydraulic system design

System Type 8

Typical Single Strata 1 boiler installation serving heating and domestic hotwater via a system pump and 2Nr 2Port motorised valves with conventional controls i.e. programmer, room stat & cylinder stat.

NOTE: system temperature will be fixed constant and direct-on-boiler weather compensation is not possible.

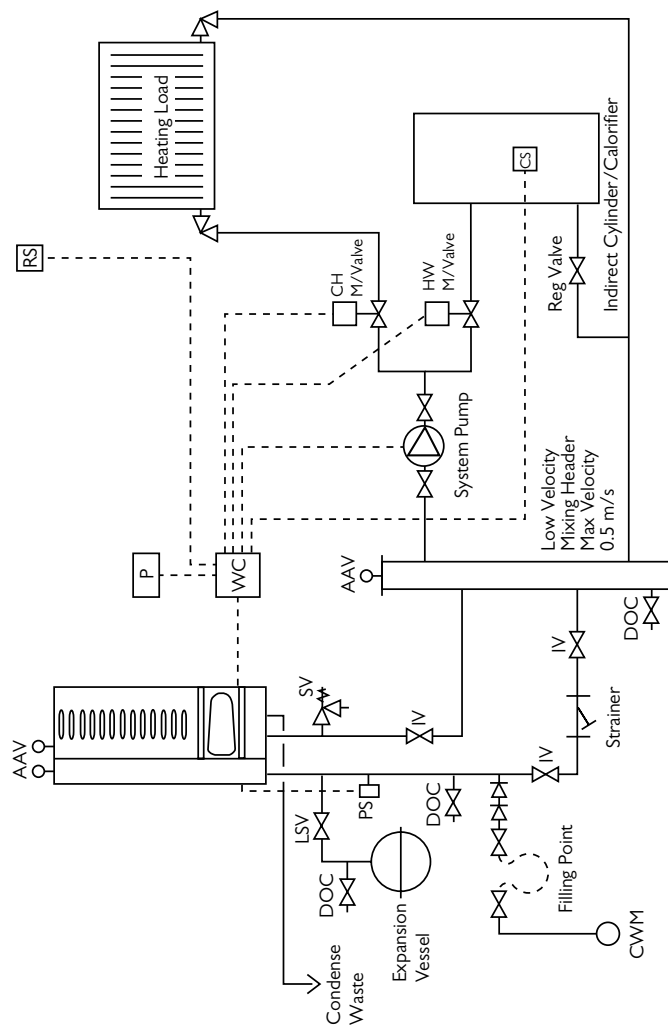

- P= Programmer
- WC= Wiring Centre/Junction Box
- RS= Room Thermostat
- CS= Cylinder Thermostat
- PS= Low water pressure cut off switch

Typical Schematic Arrangement Where System Has Multiple Pumps That Will Operate At The Same Time.

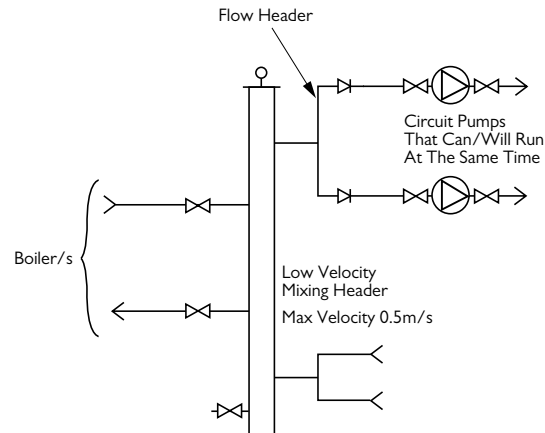

17.1 water treatment *system cleaning*

The entire system must be thoroughly cleansed and flushed to remove debris, flux residues etc before opening the boiler isolation valves & flooding the boiler. Particular care must be taken where the Strata boiler is being retro-fitted into an old/existing system, as system silt or magenite can be very damaging to the new boiler.

Following cleansing and flushing the system must be dosed with a good quality water treatment to prevent corrosion and the formation of scale.

Failure to observe these requirements will render the guarantee on the product void. Cleansing, flushing and water treatment must be carried out in accordance with the requirements of BS 7593:1992.

17.2 inclusion *of strainers*

The return pipework must include some method of filtering or straining. The Filter or strainer must be fitted with isolation valves to allow easy cleaning with the minimum amount of water loss and water replenishment.

17.3 low water *pressure protection*

A low water pressure switch must be included within the system design and interlocked to the boiler to shut the boiler down in the event of the water pressure falling below 0.5 bar.

17.4 care with the use of soldering flux

The Strata 1 boiler has heat exchangers fabricated from 316L stainless steel. It is most important that the compatibility of any flux is checked with the flux supplier before use, and that any flux manufacturers recommendations are strictly followed with regards to use in conjunction with stainless steel.

18.0 electrical connection

The electrical connections to the Strata 1 boiler are made via discreet plugs and sockets (Weiland Type) which are located within the boiler case and below the control panel.

Connections must only be made using appropriate diameter multi strand flex cables and cable entry must only be via the rubber glanded cable entry points located at the bottom rear r/h side of the appliance. If the boiler is to be room sealed flued then care must be taken to ensure the cable entries are reasonably air tight.

For electrical connection plug/socket function and location see fig 20.

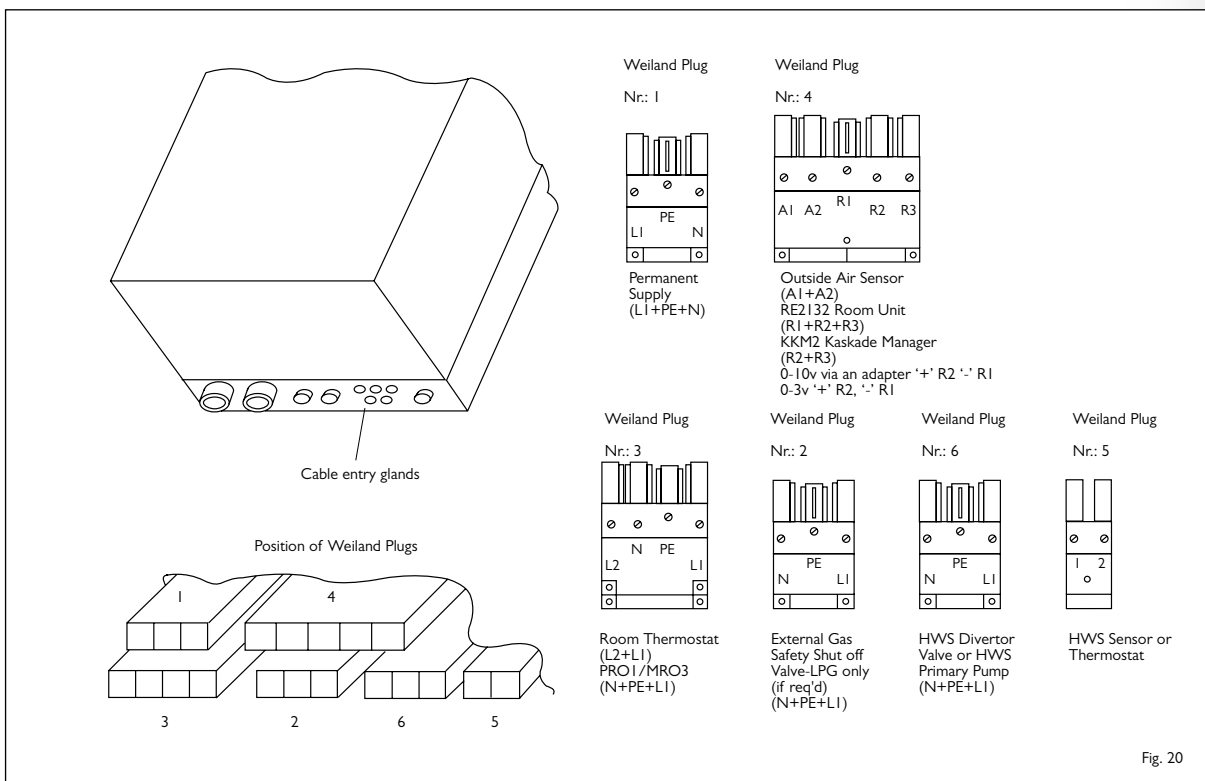

Plan of internal electrical connections

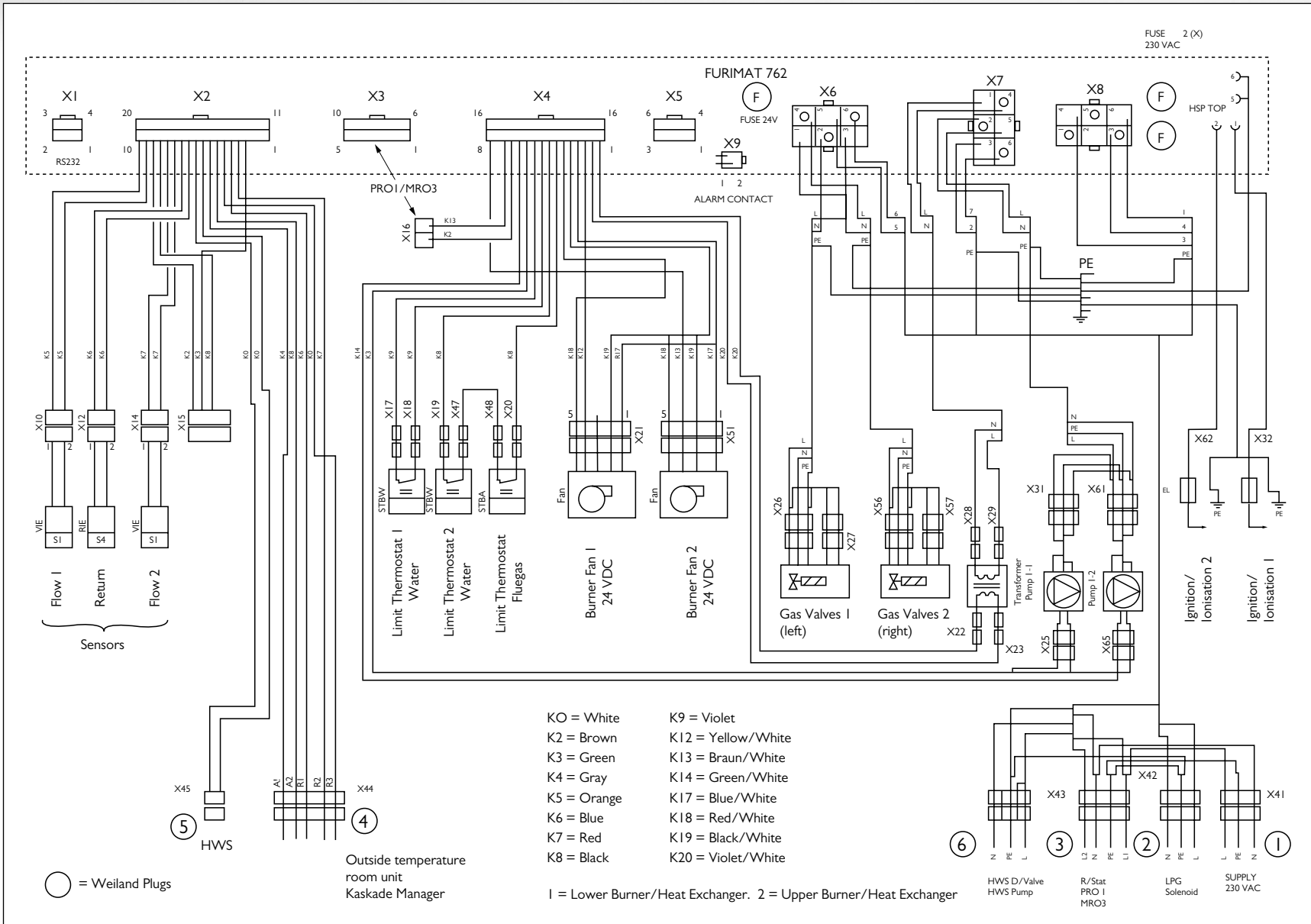

typical electrical connection schematic to suit system type I

① ③ ④ ⑤ ⑥ = Weiland Plugs/Sockets
 X3,X16 = Controls Sockets on Control panel

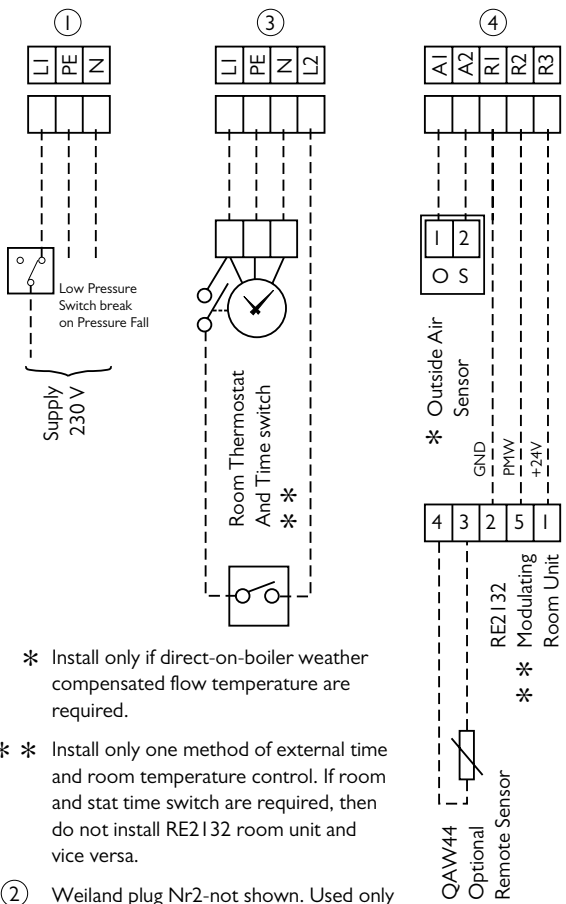

- * Install only if direct-on-boiler weather compensated flow temperature are required.
- * * Install only one method of external time and room temperature control. If room and stat time switch are required, then do not install RE2132 room unit and vice versa.
- ② Weiland plug Nr2-not shown. Used only on LPG installations where an additional remote gas safety shut off valve is req'd.

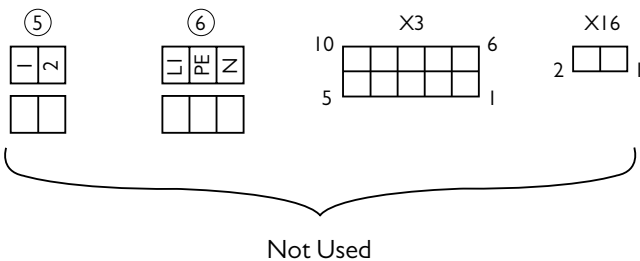

Boiler Dip Switch Settings

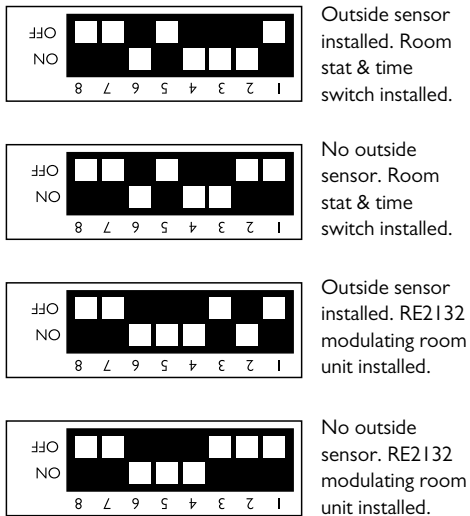

① ③ ④ ⑤ ⑥ = Weiland Plugs/Sockets
 X3, X16 = Controls Sockets on Control panel

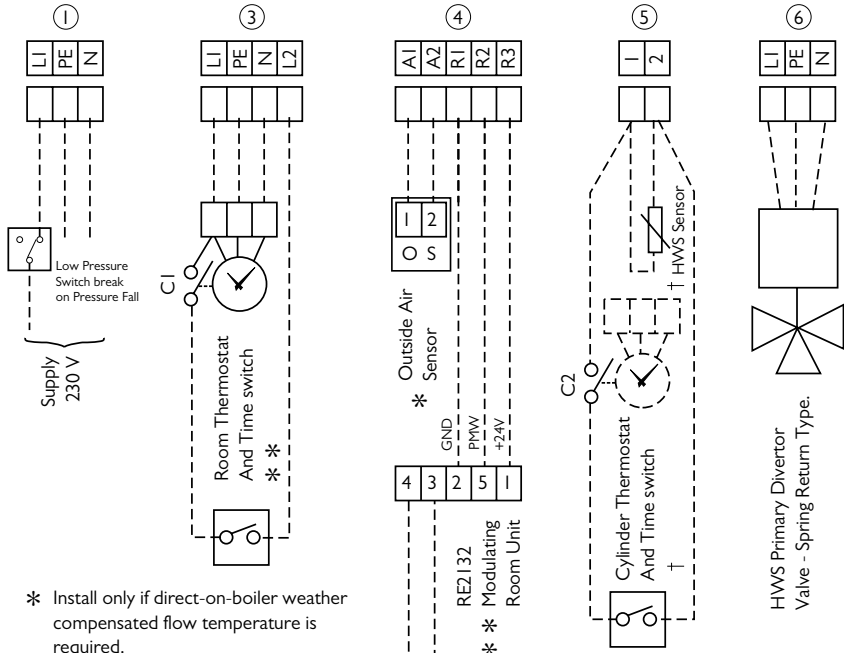

- * Install only if direct-on-boiler weather compensated flow temperature is required.
- * * Install only one method of external time and room temperature control. If room and stat time switch are required, then do not install RE2132 room unit and vice versa.
- † Install only one method of HWS temperature control. The use of an HWS Sensor will allow no time control over hotwater production. If timed hotwater control is req'd then do not install an HWS sensor, but install only a timeswitch & cylinder T/stat.

② Weiland plug Nr2-notshown. Used only on LPG installations where an additional remote gas safety shut off valve is req'd.

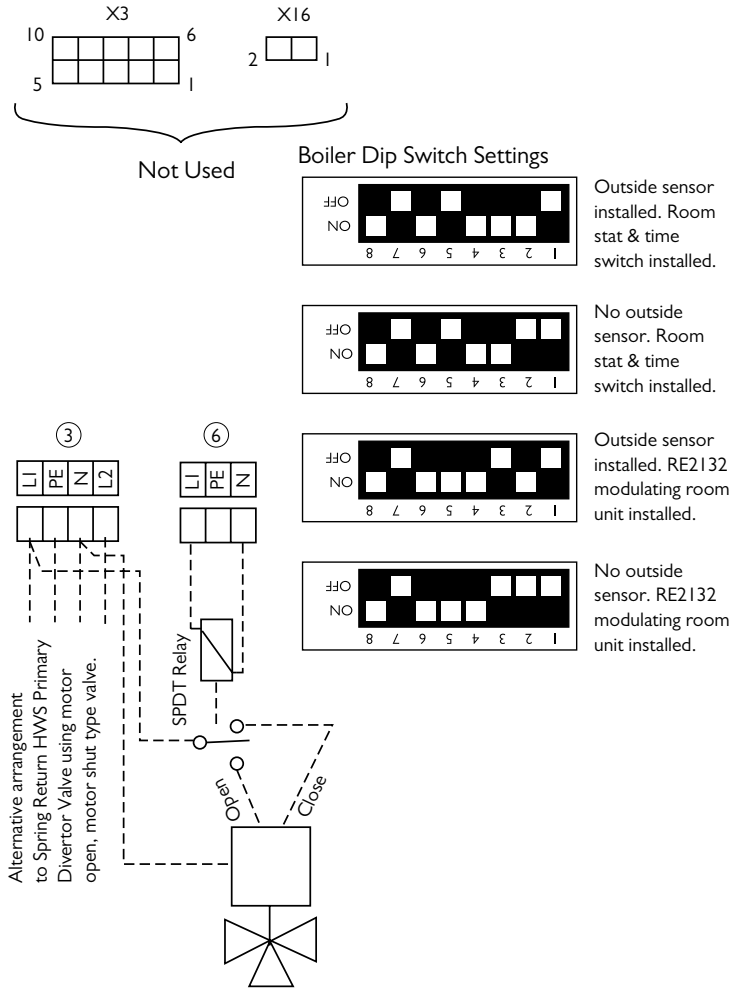

typical electrical connection schematic to suit system type 2

typical electrical connection schematic to suit system type 3

① ③ ④ ⑤ ⑥ = Weiland Plugs/Sockets

X3,X16 = Controls Sockets on Control panel

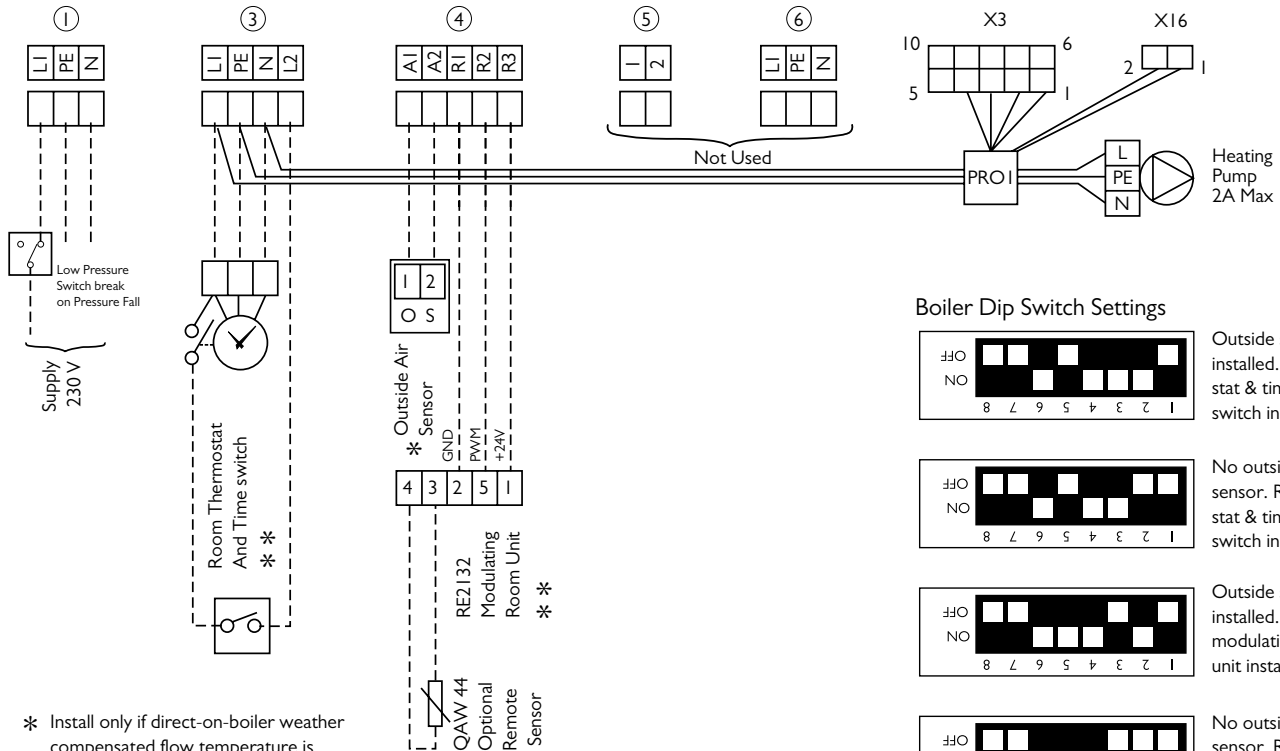

NOTE: re cables into PRO 1

Boiler Dip Switch Settings

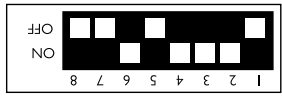

Outside sensor installed. Room stat & time switch installed.

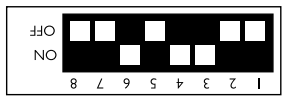

No outside sensor. Room stat & time switch installed.

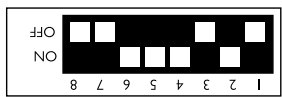

Outside sensor installed. RE2132 modulating room unit installed.

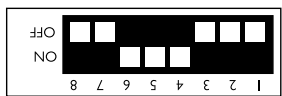

No outside sensor. RE2132 modulating room unit installed.

- * Install only if direct-on-boiler weather compensated flow temperature is required.
- ** Install only one method of external time and room temperature control. If room and stat time are required, then do not install RE2132 room unit and vice versa.

② Weiland plug Nr2-notshown. Used only on LPG installations where an additional remote gas safety shut off valve is req'd.

typical electrical connection schematic to suit system type 4

① ③ ④ ⑤ ⑥ = Weiland Plugs/Sockets

X3,X16 = Controls Sockets on Control panel. PRO1 has factory made on plugs and leads for these connections

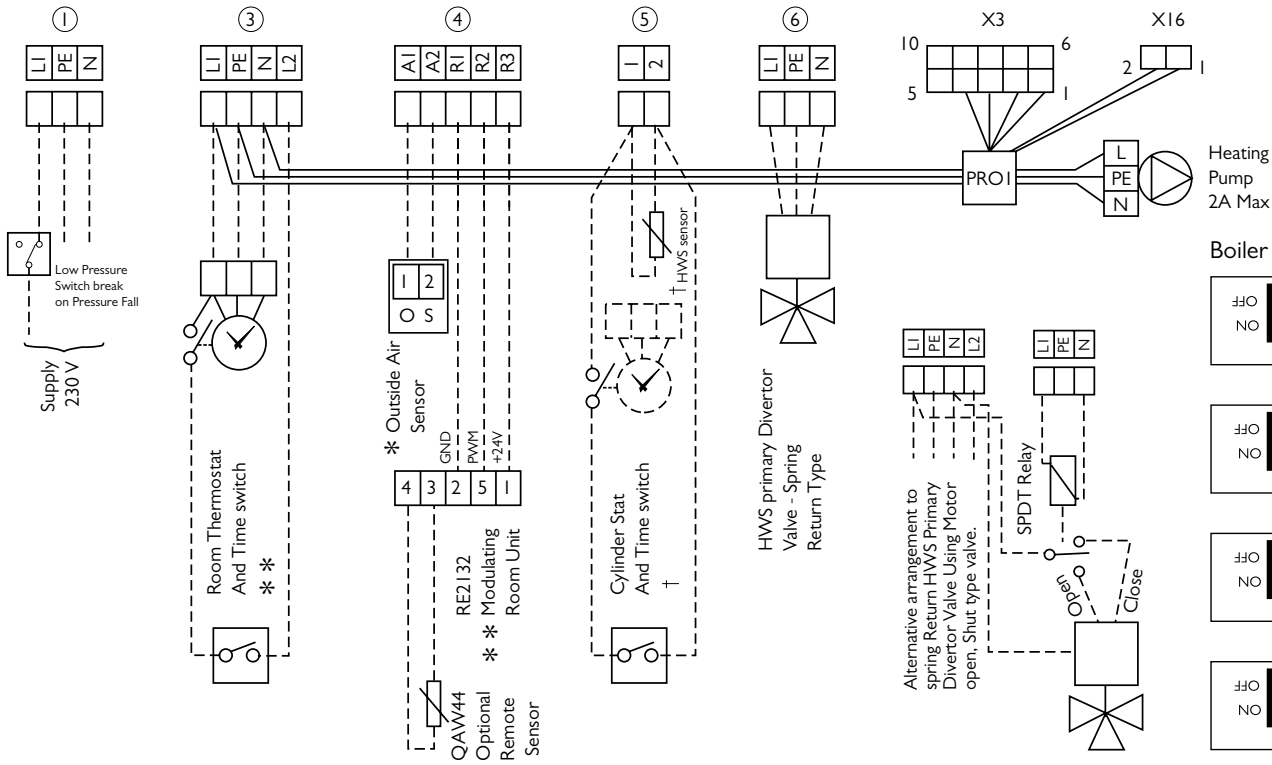

NOTE: All connections into PRO1 are made Via labelled factory fitted cables.

Boiler Dip Switch Settings

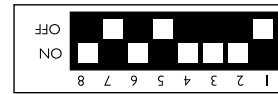

Outside sensor installed. Room stat & time switch installed.

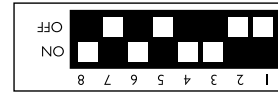

No outside sensor. Room stat & time switch installed.

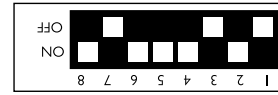

Outside sensor installed. RE2132 modulating room unit installed.

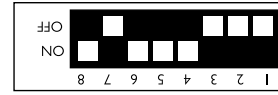

No outside sensor. RE2132 modulating room unit installed.

* Install only if direct-on-boiler weather compensated flow temperature are required.

* * Install only one method of external time and room temperature control. If room and stat time switch are required, then do not install RE2132 room unit and vice versa.

† Install only one method of HWS temperature control. The use of an HWS Sensor will allow no time control over hotwater production. If timed hotwater control is req'd then do not install an HWS sensor, but install only a timeswitch & cylinder T/stat.

② Weiland plug Nr2-notshown. Used only on LPG installations where an additional remote gas safety shut off valve is req'd.

typical electrical connection schematic to suit system type 6

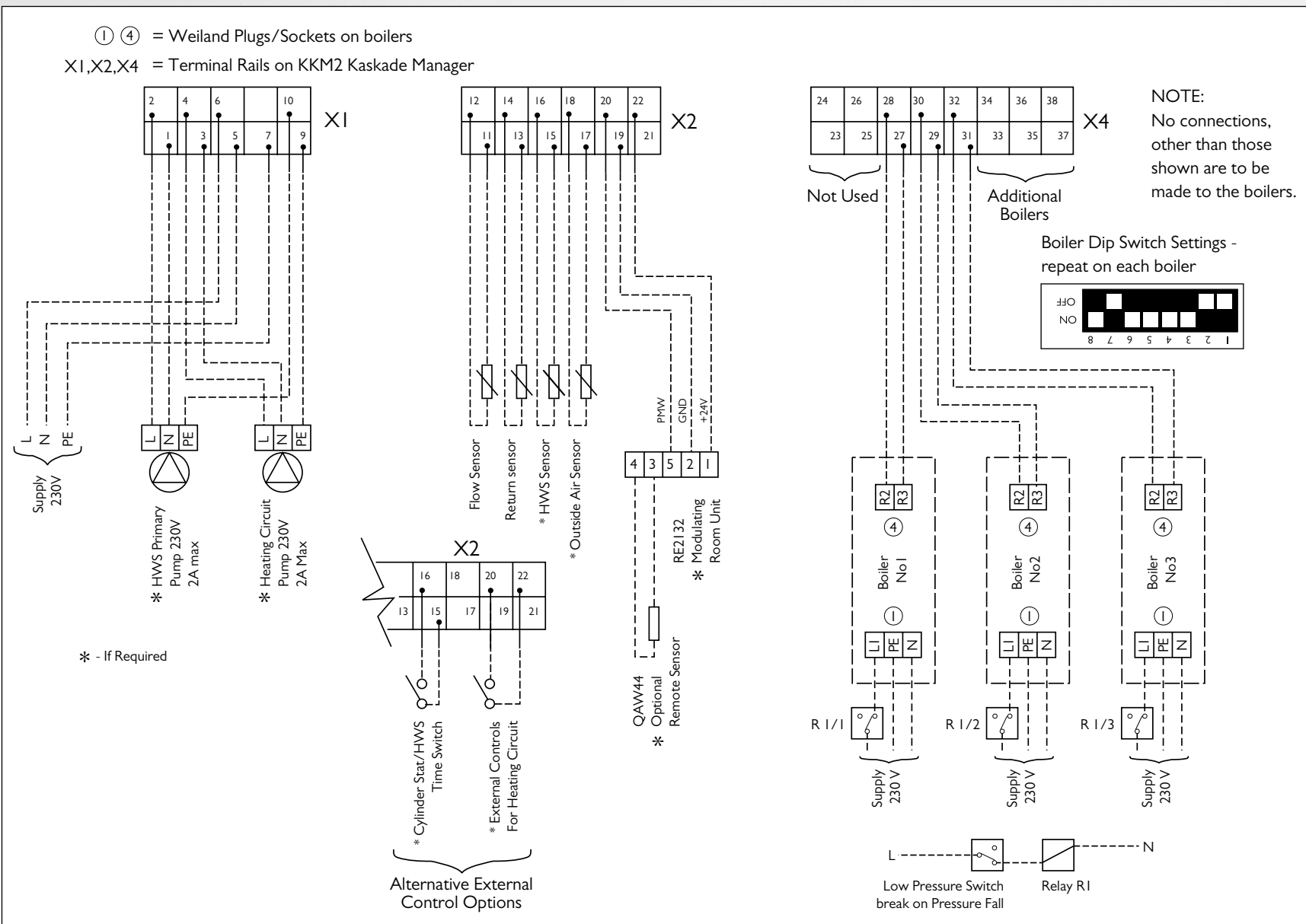

typical electrical connection schematic to suit system type 7

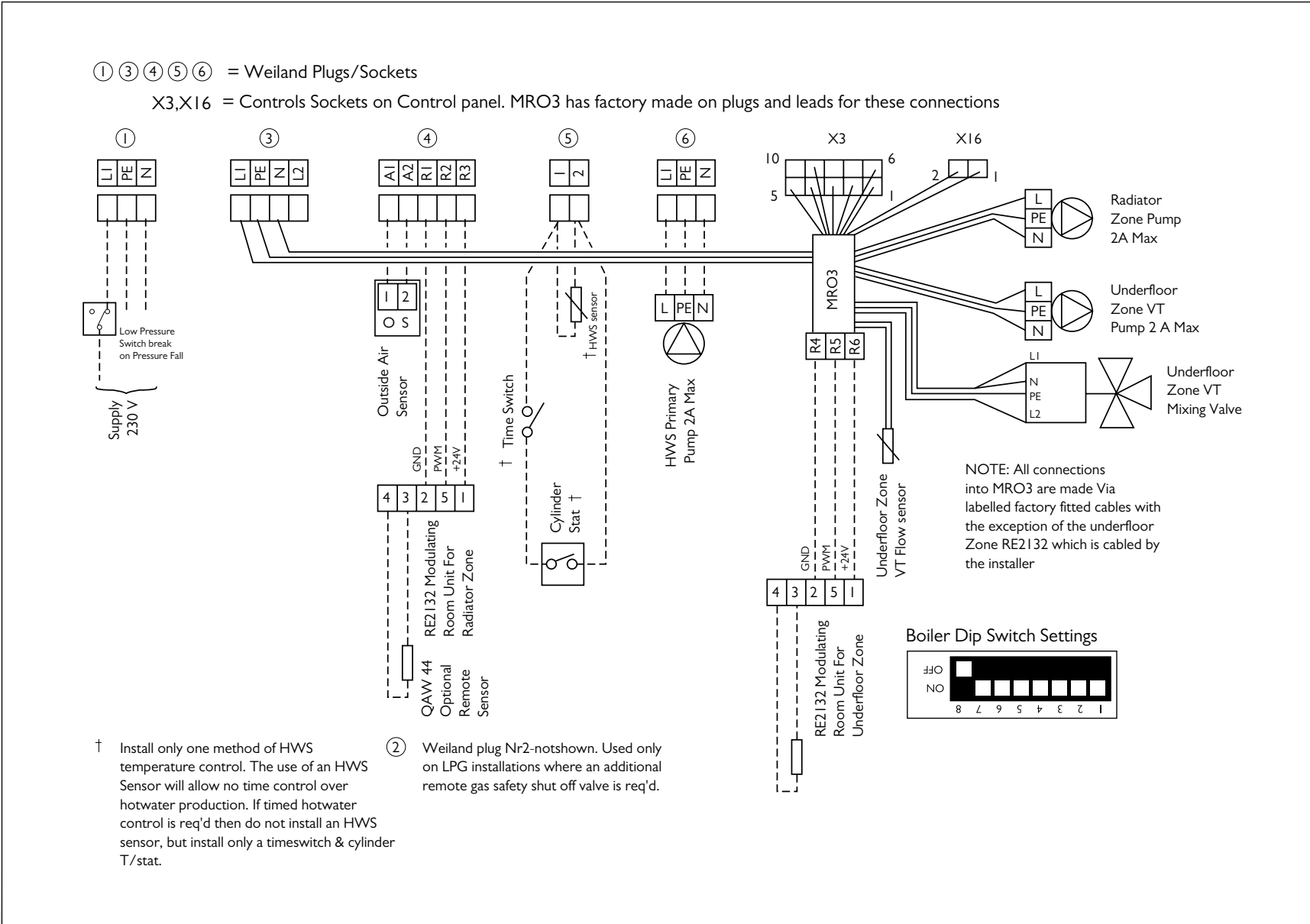

typical electrical connection schematic to suit system type 8

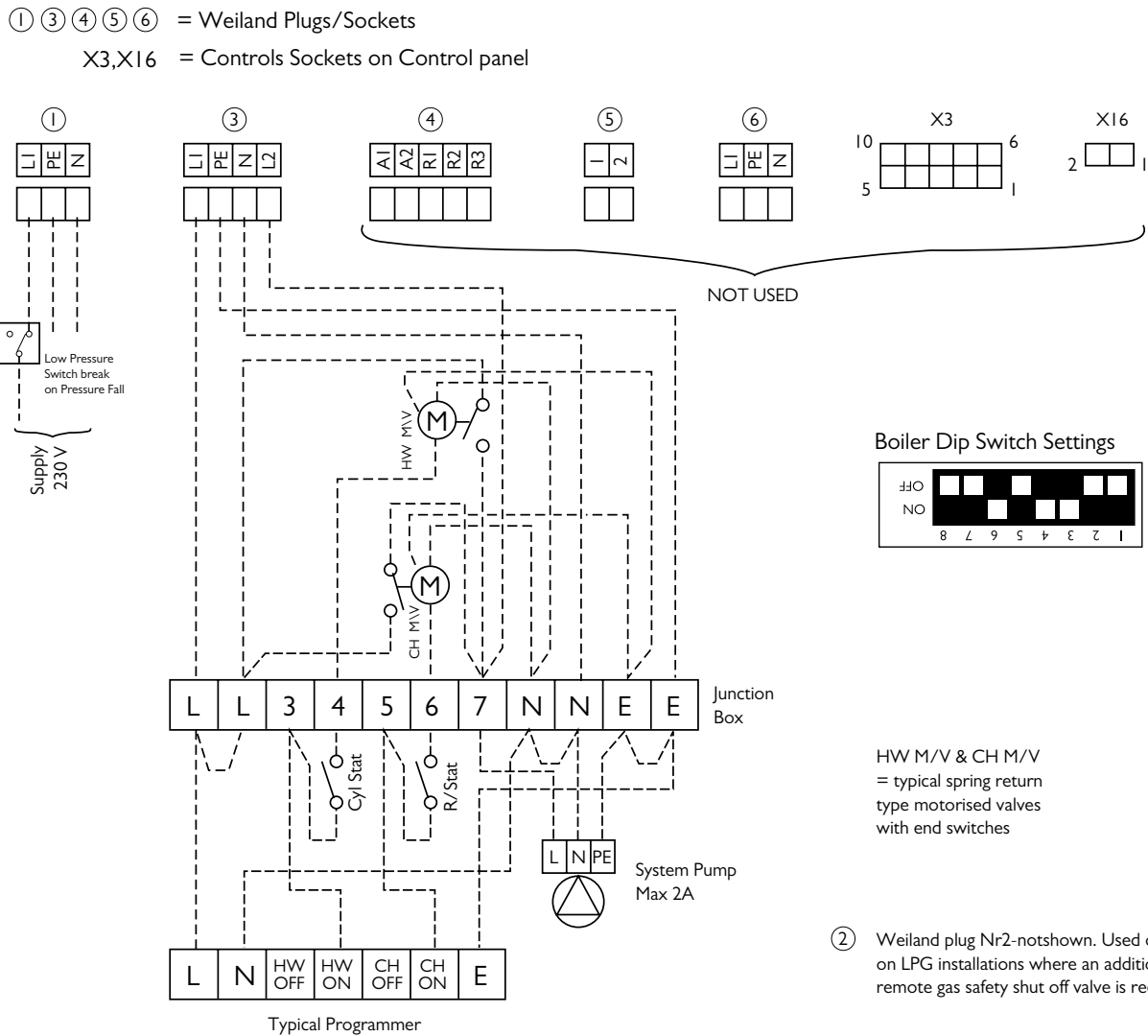

18.1 0-3/0-10 volt control

The Strata 1 can be operated via 0-3 volt or 0-10 volt control. The connection details are shown in fig 22. For further details on 0-3 or 0-10 volt control please contact the Technical Department.

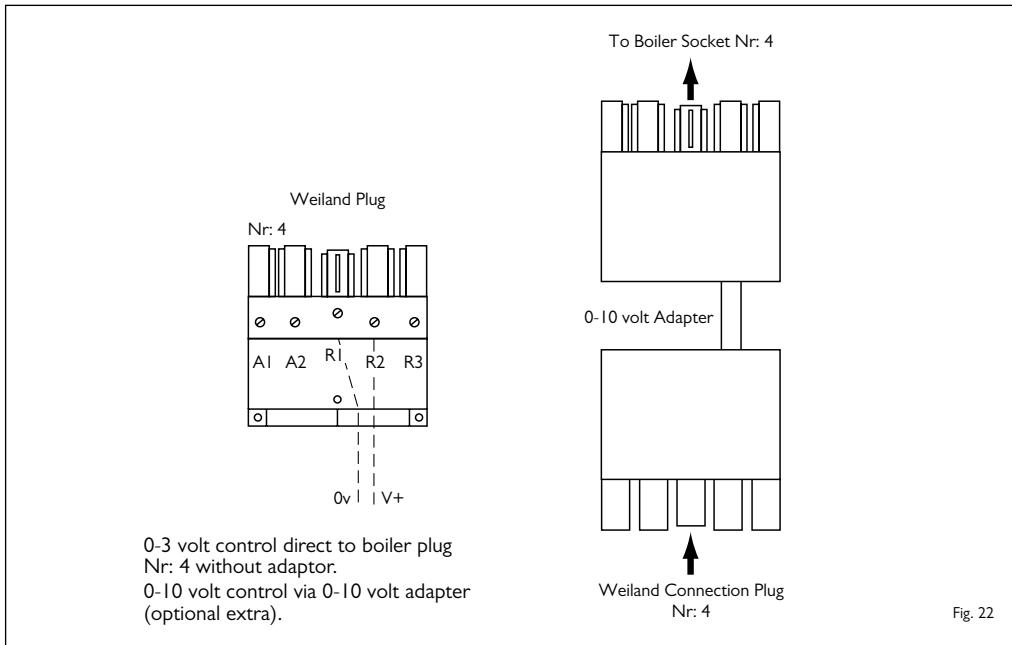

Remote Fault Indication

The Strata 1 boiler includes a built in fault alarm relay with volt free contacts for interface with, if required a remote alarm indicator.

The volt free contacts within the boiler control panel will close in the event that the boiler goes to a fault resulting in boiler lockout. The volt free contacts indicate "common alarm" upon closing. The actual fault description will be displayed upon the LCD screen of the boiler.

Connection to the volt free contacts is made via an alarm plug and lead assembly available from MHS Boilers Ltd.

The alarm plug and lead connects to socket x9 located in the lower area of the boiler control panel.

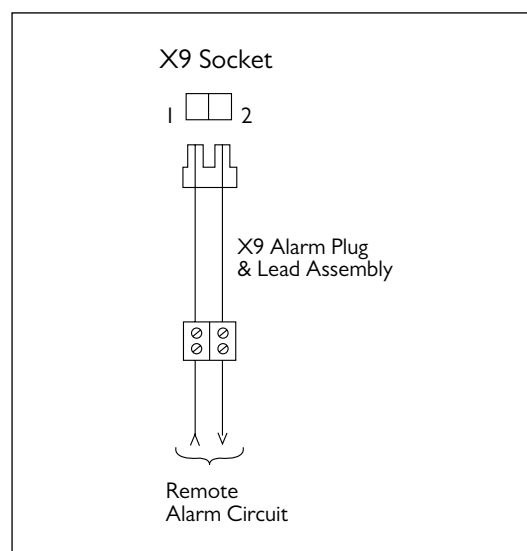

19.0 commissioning the Strata 1 boiler

The Strata 1 boiler should be expertly commissioned by a competent engineer who will need, in addition to standard hand tools, a U tube manometer and a combustion analyser.

Before attempting to set the Strata 1 boiler to work, the following check list must be worked through. See 19.1.

19.1 Pre-commissioning checks

- a) Ensure system has been thoroughly cleansed and flushed, any strainers have been cleaned and that the appropriate water treatment has been added to the system to prevent corrosion, scale formation etc.
- b) Ensure the system and boiler has been properly and fully flooded and vented of air and the cold fill pressure at the boiler is at a minimum 0.5 bar.
- c) Check that the pumps within the boiler are free to rotate by removing the vent screw in the end of both pump motors and checking that the impeller shafts rotate freely when turned with an appropriate sized screwdriver. Replace vent screws.
- d) Ensure Gas supply has been purged and there is the availability of working inlet pressure of nominal 20 mbar (Nat gas) or 37 mbar (LPG).
- e) Check that the flue installation has been properly made.
- f) Check that a condense waste pipe (in plastic - copper tube is not acceptable) has been connected to the boiler and that the syphon cleaning point cap is in place.
- g) Where the appliance is taking air for combustion from the room in which it is installed - ensure an adequate provision for ventilation has been made.
- h) Ensure that there is an adequate heat load available.
- i) Ensure that the electrical connections have been made correctly.
- j) Ensure that the appliance has been correctly configured via the Dip switches located on the bottom right hand side of the control panel. See Dip switch setting table in 19.2.

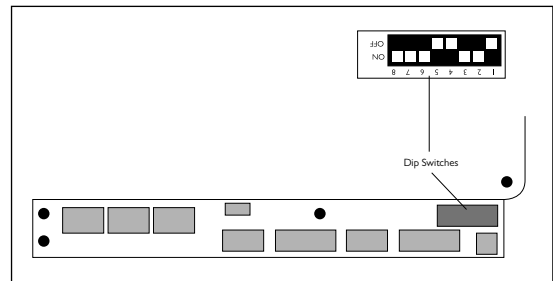

19.3 First Firing

Notes

The Strata 1 boiler has 2Nr Heat Exchange and Burner Assemblies. The Lower Assembly is referred to as No1 and the upper as No2. There are two gas valves - one for each burner; the left hand gas valve serves the lower assembly (No1), and the right hand gas valve serves the upper assembly (No2).

- a) Ensure gas & electricity supplies are turned on to the appliance.
- b) Switch on the boiler at the on/off switch. (See figure 20) The appliance will purge both combustion chambers with air from the burner fans and then will pulse the pumps on/off (venting) to push away any air that may be remaining in the heat exchangers.

19.2 dip switch settings

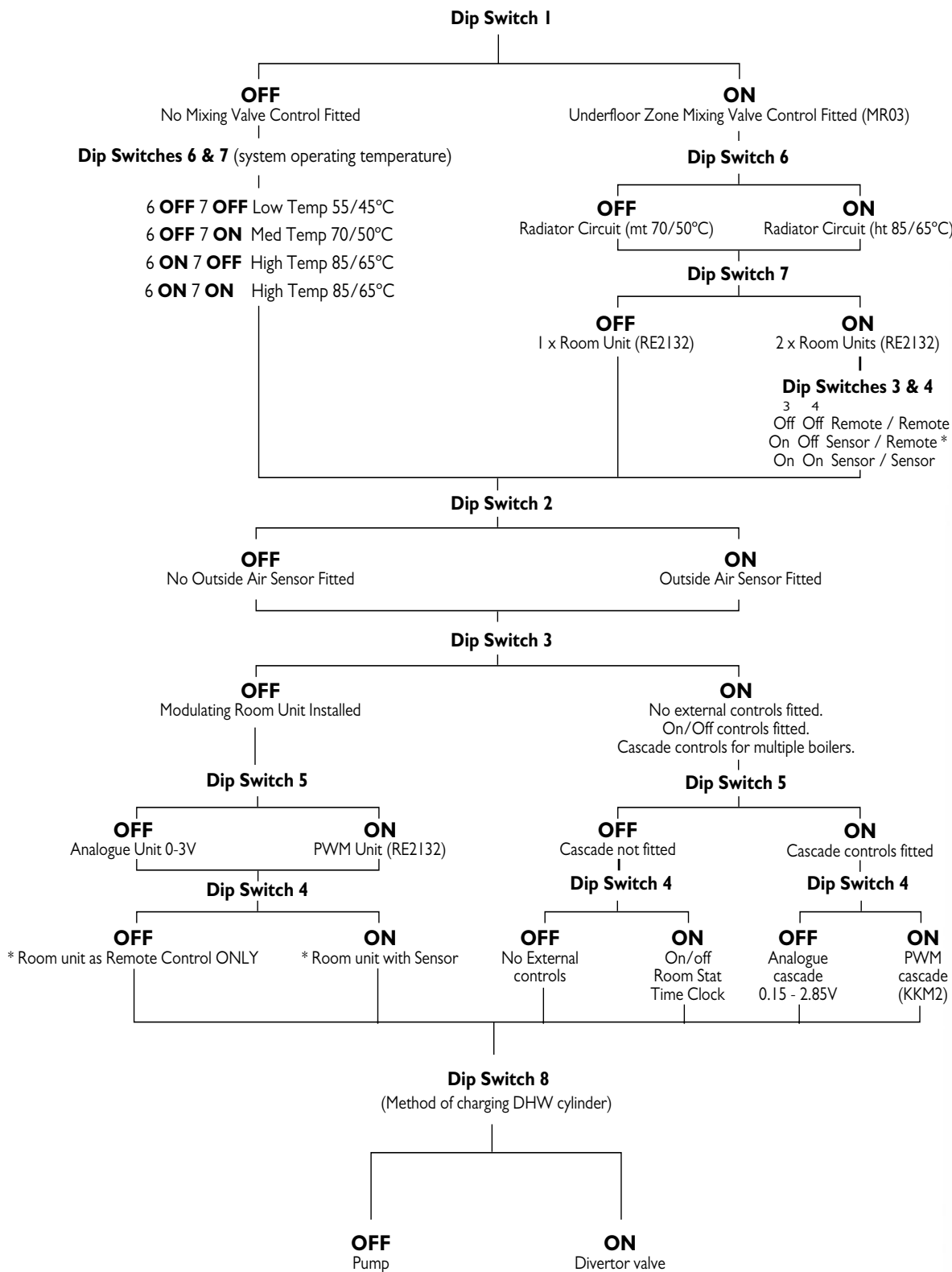

* Remote = Room unit with temperature sensor turned off and unit acting just as a remote controller

Sensor= Room unit with temperature sensor active

19.3 First Firing (contd)

- c) Turn the green potentiometer (HWS) fully clockwise(60°C).
- d) Attach U tube manometer to inlet pressure test point on right hand gas valve (See figure 21) nominal pressure should be 20mb for NG or 37mb for LPG.
- e) Press the “Engineers” test button twice - the screen should/must display “10 min Low”. The boiler should now ignite and following stabilisation of the flame, will turn down to and hold at minimum output. In the event that ignition of one or both burners does not occur after 4 attempts the appliance will go to ignition failure lockout. Remove the cover cap screws from Qmin adjustment on gas valves (See figure 21 (3)) turn adjustment screw half turn clockwise.

Press reset button, appliance will post purge and vent again.

Press Engineers test button twice to reset appliance to “10 min Low” and ignition sequence will start again. If ignition fails again after 4 attempts, then further increase Qmin on each gas valve by half turn until burners ignite.

- f) Observe the colour of both burner flames - correct colour should be dull red. Adjust colour of burner flames using Qmin until flame colours are correct. Following this procedure will avoid poisoning your combustion analyser.
- g) Remove flue gas analysis test point cap or plug (from top right of combustion chamber) of the lower heat exchanger and insert probe of combustion analyser. Adjust as necessary Q min of left hand valve to obtain required CO₂% value. (See table 1) Make adjustments slowly and wait at least 2 minutes for reading to stabilise before re-adjusting. Remove analyser and refit cap/plug to test point. Repeat above procedure with upper heat exchanger and right hand gas valve.

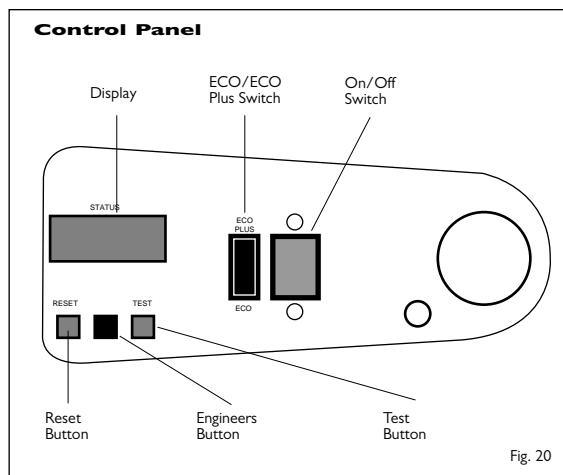

Fig. 20

Table 1.

Flue gas CO ₂ % Settings		
Gas Type	Nat Gas G20	LPG G31
CO ₂ % at min output	9-9.5	11-12
CO ₂ % at max output	8.7-9.2	10-11

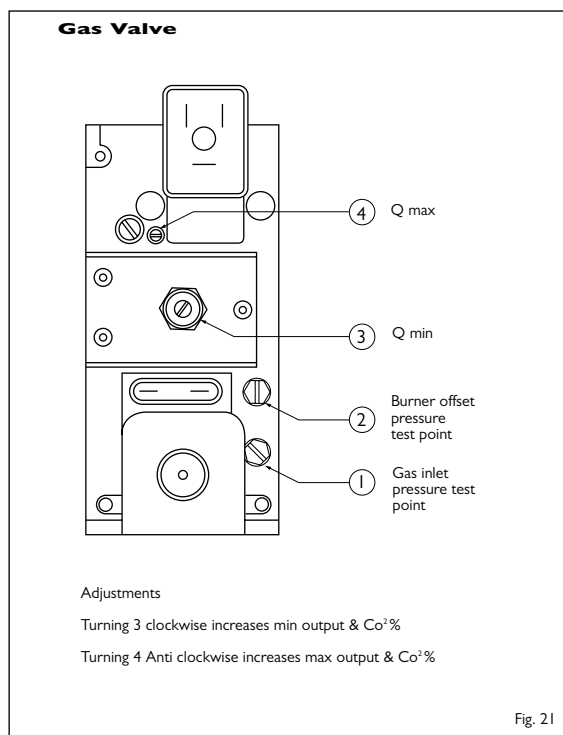

Fig. 21

19.3 First Firing (contd)

NOTE: Test period expires after 10 minutes - if this expires whilst commissioning is still in progress, press Engineers button twice to reset and carry on with necessary checks and adjustments. To exit "10 min Low" test period - press Engineers button once, this will set controls to auto.

- h) Turn the green potentiometer (whilst still in "10 min Low" operation) fully anti-clockwise (20°C). This will set the burners to maximum output.
- i) Check CO₂% of upper heat exchanger and adjust as necessary screw (4) Q max of right hand valve, to obtain required value. (See table 1)

NOTE: Adjustment of either (3) Q min or (4) Q max will affect the other adjustment to a lesser or greater extent. Following either adjustment of (3) or (4) check the effect on the setting of the other adjustment and correct as necessary.

- j) Remove analyser from upper heat exchanger and refit cap/plug to test point.
- k) Repeat operations described in i) and j) but on lower heat exchanger and left hand gas valve.
- l) Press Engineer 's test button once to exit 10 minute test mode.
- m) Turn off electricity and gas supplies and remove manometer from inlet pressure test point and refit test point screw.
- n) Turn on gas and electricity supplies.

19.4. Setting Weather Compensation

- a) If direct-on-boiler weather compensated flow temperatures are required, then ensure the (supplied) outside air temperature sensor has been installed and Dip switch No2 has been set to "on".

The boiler is supplied with the compensation slope shown overleaf set as a default.

NOTE: The default slope is obtained when the red and blue potentiometers are set in the vertical position.

- b) If the default settings are not applicable to the needs of the system user, then the angle of the slope may be changed by adjustment of either the blue or red potentiometers or both.

Adjustment of the red potentiometer raises or lowers the flow temperature at low outside (design) air temperature.

Adjustment of the blue potentiometer raises or lowers the flow temperature at the end point (high) outside air temperature.

Each potentiometer has the range of +20°C and -20°C about the default point but with a limiting factor that the maximum flow temperature is 85°C.

See graphs following showing range of parallel displacement of the compensation slopes.

STRATA 1

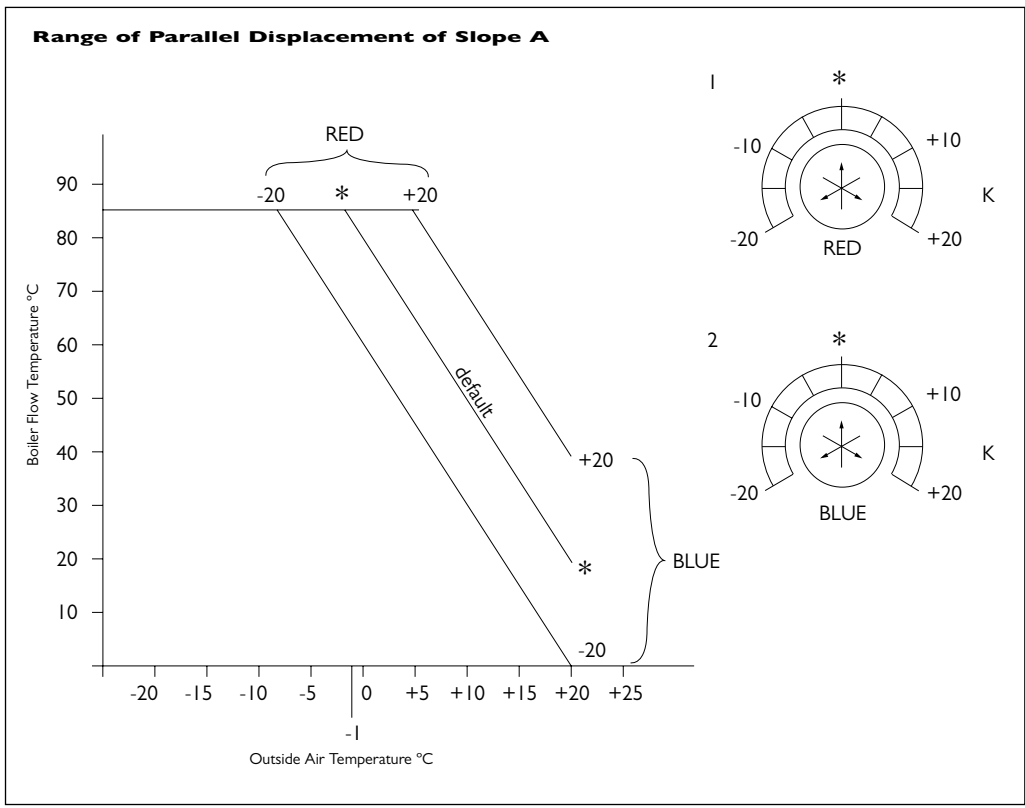
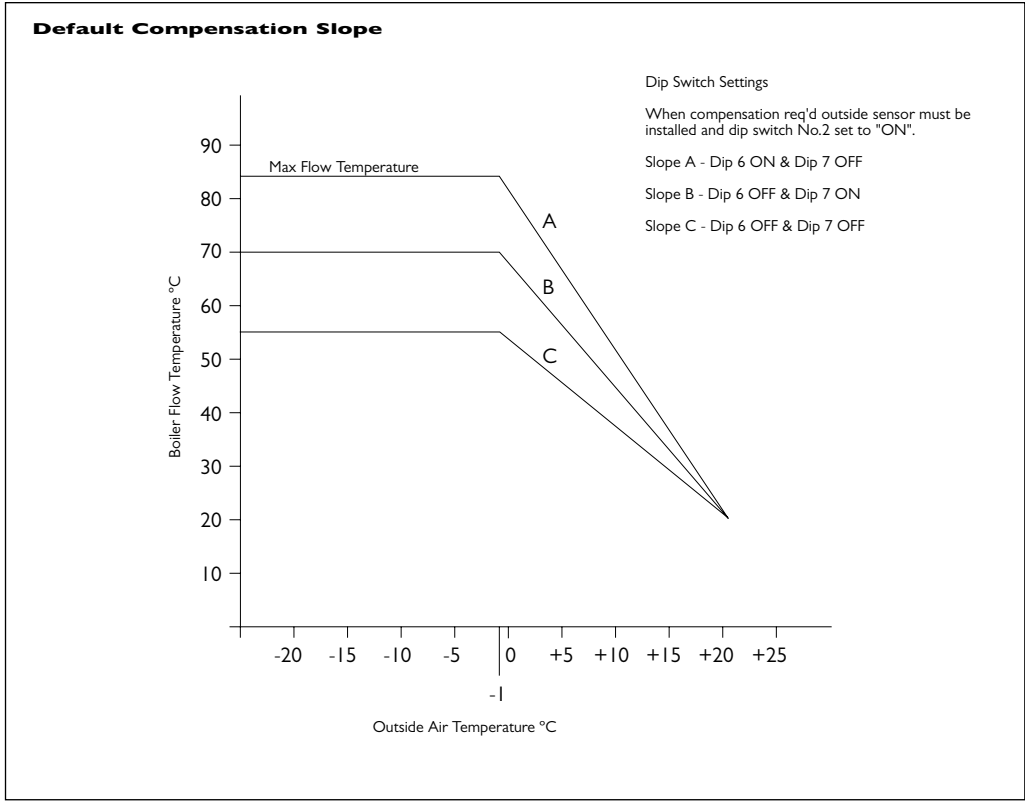

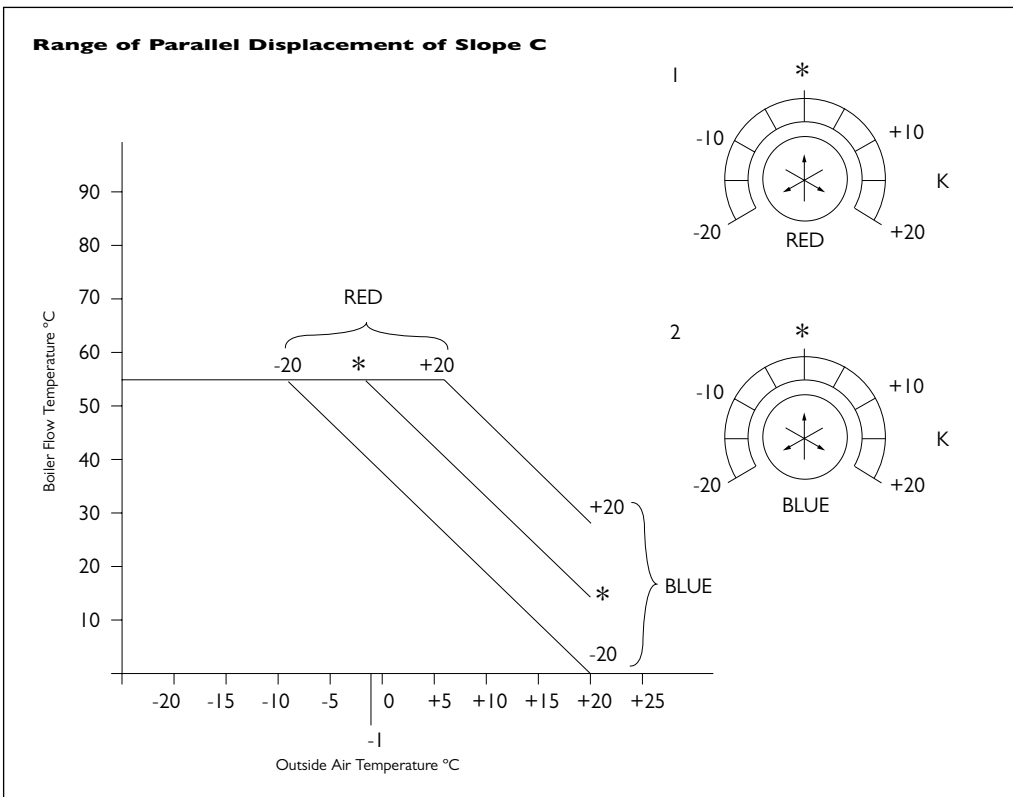
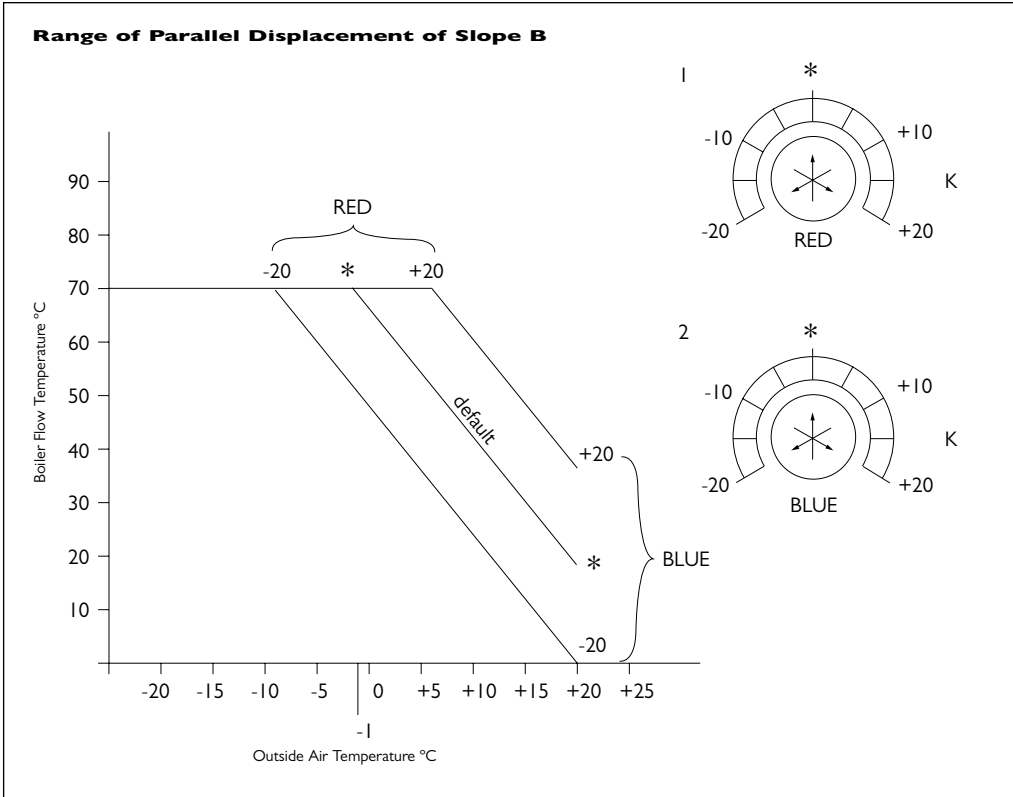

19.5 Setting domestic *hot water temperature*

- A) With HWS sensor in/on DHW Calorifier.
- l) Set desired stored hotwater temperature by using the “green” potentiometer on the boiler control panel. This arrangement will give the potential to charge hot water continuously (24 hour/day) with priority over the heating demand. This arrangement is recommended only with high/quick recovery type calorifiers.
- B) With cylinder thermostat in/on DHW Calorifier.
- l) Set desired stored hot water temperature by the adjustment of the cylinder thermostat. With this arrangement the “green” potentiometer on the boiler control panel has no function. With this arrangement time control of hot water charging is possible by installing a time switch in series with the cylinder thermostat, but hot water charging always takes priority over the heating demand.

19.6 Service button/setting heating output, *pump speeds and minimum mixed flow temperature.*

The service button is located adjacent to the Dip switch block (bottom right hand of control panel) and has a number of functions.

- a) Setting maximum output to heating.
The output to heating may be limited if required and may be set between 20% and 100%, by performing the following:
- i) Press “red” reset button once.
Press service button once.
Screen display will show “Mxhea”??>??%
The figures to the left of the “>” symbol are the current settings for maximum heating output as a percentage of the maximum output of the boiler.
- ii) To change the output, turn the “red” potentiometer and the figures to the right of the “>” symbol will change. Set the required % output by adjusting the “red” potentiometer. - - equals 100%.
- iii) To “store” the new setting: press the service button once.
- iv) If no further adjustments are required then set “red” potentiometer back to it’s original position as this affects the compensation slope setting if compensation is active.
- b) Setting maximum pump speed. (Normal setting 100%)
If it is required to limit the maximum speed of the in built boiler pumps then this may be done by the following:
- i) Press “red” reset button once.
Press service button once.
Press “red” reset button twice.
Screen display will show “Mx pum”??>??%.
- ii) To change maximum pump speed (not recommended, normally left at - - (100%) follow procedure as in a) ii)-iv) above.

19.6 Service button/setting heating output. (contd)

- c) Setting minimum pump speed.
If it is required to limit the minimum pump speed of the in built boiler pumps then this may be done by the following:
- i) Press “red” reset button once.
Press service button once.
Press “red” reset button three times.
Screen display will show “Mn pum”??<??%
 - ii) To change minimum pump speed then follow procedure as in a) ii)-iv) above.
- d) Setting minimum mixed flow temperature.
Only applicable where MR03 underfloor zone controller is installed.
If it is required to set a minimum mixed flow temperature at the outlet of underfloor zone VT value, then this may be done by the following:
- i) Press “red” reset button once.
Press service button once.
Press “red” reset button four times.
 - ii) To set minimum mixed flow temperature follow procedure as in a) ii)-iv) above.
- e) Clearing “service” message from screen display.

After a default of 365 days of an electrical supply being applied to the boiler, a message to the user is shown on the screen displaying “service”, reminding the user that the appliance should now be serviced.

Following a service visit by the specialist engineer, the service message may be cancelled by pressing and holding the service button for approximately 10 seconds.

19.7 Output for charging *hot water*

There is no adjustment necessary or possible, as the boiler controls are self learning and will self adapt the optimum output to hot water according to the heat transfer capabilities of the connected hot water calorifier or cylinder.

20. Setting the boiler *to work*

1. To fit casing to boiler ensure hooks on top rear edge of boiler case engage properly into rear chassis assembly.
Latch bottom case fixings and tighten central locking screw.
2. Turn ON on/off switch and set any external controls to auto operation.
3. Set ECO/ECO plus switch to ECO position for systems without additional heating circuit pump
OR Set ECO/ECO plus switch to ECO plus position for systems with a local low velocity header and additional heating circuit pump.
4. With boiler operating (burners on) press “Test” button on boiler control panel to test overheat controls in the boiler. The boiler must shut-down and then re-ignite.

21. Servicing *instruction*

GENERAL

In general, maintenance/inspections should take place:

- a) When the display on the unit indicates that inspection is required (status shows "SERVICE").
- b) At least every 18 months, before carrying out any maintenance the unit must be inspected.

21.1 Inspection

- a) Ask the user about any problems with the boiler unit or any other comments.
- b) Check the water pressure of the installation.
- c) Remove the casing of the unit and inspect all pipes and connections for water leaks.
- d) Inspect the top of the casing and/or the top of the upper heat exchanger for water leaks or signs of water from the flue air supply tube.
- e) Open the siphon cleaning rinsing point at the base of the unit and drain syphon into a suitable receptacle.
- f) If you have a notebook computer, connect it and check the service page for any errors, messages, starts and successful restarts. (Special communication lead and service software required)
- g) Run the unit at maximum capacity and measure the input and the CO₂%.
- h) Run the unit at minimum capacity and measure the input and the CO₂%.
- i) Listen to the sound of the in built pumps.
- j) Disassemble each burner by removing the six M6 nuts around the burner door, removing the ignition cable and pulling the burner forwards.

When the burner has been pulled forwards to halfway across the burner area, the plug on the fan cable must be removed from the fan motor.

Check the interior of the heat exchanger.

- k) Disassemble the plastic box at the suction side of the fan, inspect the fan blades.
- l) Check the distance between the electrode and the burner; this should be 4 to 5 mm.

21.2 Maintenance

Depending on the results of the inspection, carry out any maintenance and if necessary any preventive maintenance.

Possible actions include:

- at a) The remarks and comments of the client must be taken seriously and the cause(s) of any faults or problems must be found.

21.2 Maintenance (contd)

- at b) The pressure of the installation must be between 1 and 2 bar: any possible leaks in the system must be identified; if necessary, have a pipework engineer solve the problem.
- at c) Possible leaks or weeping must be resolved immediately.
- at d) In case of water leakage or ingress from the air supply pipe, the cause must be found.
- at e) The siphon must be rinsed. With the burners removed, use a filling hose to insert water into the heat exchanger, which will automatically reach the siphon. Rinse volume should be a minimum of 2 litres.
- at f) Draw your conclusions from the service screen and attend to those parts that have caused any faults.
- at g) and at h)
If necessary, adjust the gas setting on the gas valves.
- at i) If the in built pumps make an un-natural noise, and in particular if the pumps are more than 5 years old, it is recommended that the pumps should be replaced by way of preventive action.

Note the pumps are fully modulating and do have characteristic “yet yet” noise which is normal at low speeds.

- at j) NEVER CLEAN THE BURNER ITSELF.
If the interior of the heat exchanger is contaminated and/or there is a deposit on the surfaces of the coiled stainless steel pipes, the latter must be removed with a hard brush or citric acid. (DO NOT USE A STEEL BRUSH !) Then remove any dirt with a vacuum cleaner.
- at k) If dirt has deposited on the fan blades, each blade must be carefully cleaned, until the blade material is visible again. If this is not done evenly the fan will not rotate properly and be out of balance.
- at l) Carefully bend the electrode without touching the burner, until the correct distance has been reached.

IMPORTANT NOTE

IF ANY WATER CARRYING JOINT WITHIN THE BOILER IS DISASSEMBLED THEN THE “O” RING SEAL MUST ALWAYS BE REPLACED, LIKEWISE IF ANY OTHER SEAL IS NOTED TO BE DEFORMED THEN THEY SHOULD ALSO BE REPLACED.

WATER SEALING “O” RINGS ARE A ONE TIME USE ONLY AND SHOULD NOT BE RE-USED.

Cancelling the Service Message

Following the maintenance operations, the service message (when displayed) must be cancelled. This is done by pressing and holding in the service button for at least 10 seconds.

22. Screen display/ *Diagnosis of faults*

22.1 Screen display

The control panel of the Strata 1 boiler has an LCD screen, displaying two lines of data. This screen provides information about the operation of the appliance; it shows operation messages (non flashing) and fault messages (flashing display). The first line contains text information about the status of the unit.

It shows:

STATUS MESSAGES (NON FLASHING) FOR NORMAL OPERATION

Standby	No heat demand (boiler not required to be on)
Pre-purge	Combustion chambers are being pre-ventilated with air from the burner fans
Ignition	The ignition sequence of the burners is initiated
Heat-operate	The boiler is operating in central heating mode
Tap-operate	The boiler is operating to produce domestic hot water
Flue-emission	The boiler is operating in test mode at mid output to enable flue gas emissions to be checked (auto expires after 10 min)
10 min Low after 10 min)	The boiler is operating in engineers test mode for adjustment purposes (auto expires after 10 min)
Post-purge	Combustion chambers are being post-ventilated with air following boiler operation
Limit F/R	The flow and/or return temperature is too high (currently)
Fan 1 high	The lower burner fan is running too fast (currently)
Fan 1 low	The lower burner fan is running too slow (currently)
Fault room u	There is a fault with the modulating unit (RE132) or Cascade manager (KKM2) or a fault in the wiring to these controls (in the case of the RE2132 the boiler runs continuously in heating mode to protect the building)
Fault outsid	There is a fault in the outside air sensor or in the wiring to the sensor or the dip switches are incorrectly set to ask the boiler to look for an outside sensor when there is none installed
Service	The service interval time has expired and the boiler should now be maintained
Serv. Button	The service button is being depressed
Fan 2 high	The upper burner fan is running too fast (currently)
Fan 2 low	The upper burner fan is running too slow (currently)
Venting	The in built pumps are operating to remove any possible collection of air from the heat exchangers. (Occurs when power turned off/on and after reset of fault)

The second line of text displays values such as temperature, percentages etc and the red reset button may be used to scroll through (for information) the values of the various sensors that are/may be connected in the boiler plus fan speeds and pump speed etc.

22.1 Screen display/Diagnosis of faults (contd)

STATUS MESSAGES (FLASHING DISPLAY) INDICATING A FAULT

A flashing display indicates a fault and that the boiler has shutdown (lockout). The boiler will not attempt to operate until the “red” reset button is pressed.

Any repetitive flashing fault message should be investigated, the cause found and corrective action taken.

for each flashing display message there is a possible cause, see list of cause numbers following the “flashing status” list.

DISPLAY MESSAGE FLASHING	MEANING	CAUSE NUMBER/S
Wat 1 Lockout	Lower ht/exch high limit stat has tripped.	5,6,7,8,21,24,25,26,31
Wat 2/Flue Lo	Upper ht/exch high limit or flue limit stat has tripped	2,5,6,7,8,21,24,25,26,31
Fan 1 high	Lower burner fan speed is too high	9,11,29,31,33
Fan 1 low	Lower burner fan speed during pre-purge is too low	9,10,11,14,18,29,31,33
Fan 1 oper	Lower burner fan is detected as operating when should be idle	3,4,11,29,31
Ignit 1 fault	Ignition to lower burner has not been successful after 4 attempts	12,13,15,16,17,19,22,23,27,29,30,31,35
Flame 1 out	Flame at lower burner has been lost on 4 consecutive occasions during operation	13,15,17,19,20,23
Flame 1 on w/	Flame is detected at the lower burner when there should be no flame	17,19,30
S1 interrupt	Lower ht/exch flow temperature sensor interrupted	3,5,33
S3 interrupt	Upper ht/exch flow temperature sensor interrupted	3,5,33
S4 interrupt	Return temperature sensor interrupted	3,5,33
S7 interrupt	Mixed flow temperature sensor interrupted. Only when MR03 unit installed	1,3,5,33
Program end	Follows reprogramming of control panel with laptop PC, not a fault - just press reset button	
Fan 2 high	Upper fan speed too high	9,11,29,31,33

22.1 Screen display/Diagnosis of faults (contd)

Fan 2 low	Upper burner fan speed too low during pre-purge	9,10,11,14,18,29,31,33
Fan 2 oper	Upper burner fan is detected as operating when should be idle	4,11,29,31
Flame 2 on/w	Flame is detected at the upper burner when there should be no flame	17,30
Ignit 2 fault	Ignition to upper burner has not been successful after 4 attempts	12,13,15,16,17,20,22,23,27,29,30,31,35
Flame 2 out	Flame at upper burner has been lost on 4 consecutive occasions during operation	13,15,17,20,23
Gas valve	Connection to gas valve interrupted	26,28,29,31,33
Soft fault	Error in software in the control	29
Reset button	There is a fault with the reset button	29,31,34
Eeprom	There is a fault in the EEPROM in the control	29

22.2 (possible) causes of fault & corrective action

CAUSE No.	REASON/ACTION
1 -	Dip switches not set correctly / Check and correct settings
2 -	Unsound electrical connections to flue limit stat / Check and correct
3 -	Sensor not correctly connected or sensor defective/Check connections and or replace sensor
4 -	Short circuit in wiring / Check and rectify
5 -	Short circuit in wiring to sensor / Check and rectify
6 -	Boiler pumps not rotating (seized or defective)/Free seized shaft or if defective replace pump
7 -	System lacks water / Investigate, refill and vent
8 -	Connections to heat exchanger limit stat unsound /check & rectify
9 -	Unsound electrical connection to fan / Check integrity of fan connection plug
10 -	Fan blades heavily contaminated / Clean fan

22.2 (possible) Causes of fault (contd)

- 11 - Fan is defective / Replace fan
- 12 - There is no gas supply available / Investigate, restore gas supply
- 13 - Low gas pressure / Investigate and rectify
- 14 - Fuse defective / Check fuses and replace as necessary
- 15 - Gas valve min output setting is incorrect / Check and adjust min output CO2%
- 16 - Oxidation on burner mounting screws. Loosen and retighten screws.
- 17 - Poor ignition lead connection to electrode or damp connection or lead damaged and shorting to earth / Check and rectify
- 18 - Transformer defective / Replace transformer
- 19 - Condense siphon is blocked or condense waste blocked or frozen / Clear siphon or waste pipe
- 20 - Flue gas leakage from connection at rear of heat exchanger / Check, reposition or replace seal
- 21 - System strainer blocked?, isolation valve closed? Or some other interruption to water flow / Check and rectify
- 22 - Unacceptably high resistance in flue or air supply tubes or flue blocked / Check flue for suitability or clear obstruction
- 23 - Leakage of flue gas from flue gas tube into air tube vitiating the combustion air / Strip out flue system and remake joints
- 24 - Zone pumps not running / Check and rectify
- 25 - Heat exchangers fouled internally with silt or scale / Clean, descale heat exchangers and system and re-dose system with water treatment
- 26 - Heat exchanger high limit stat defective / Replace limit stat
- 27 - Boiler set for wrong gas type / Convert boiler to burn the gas being supplied
- 28 - Flue gas limit stat defective / Replace limit stat
- 29 - Boiler control panel defective / Replace control panel
- 30 - Incorrect position of ignition electrode / Reset gap 4-5mm
- 31 - moisture in-on electrical connections or components / Dry carefully using warm air from a hair dryer
- 32 - Incorrect electrical connection / Check and rectify
- 33 - Wiring interrupted (broken wire) / Check and rectify
- 34 - reset button stuck / Press button in attempt to free sticking contacts. If no success then replace control panel
- 35 - Ignition electrode damaged or broken / Replace electrode²³. User instructions

23.0 Instructing *the user*

The installer should inform the user about the operation and use of the Strata 1 boiler and in particular point out:-

- Any safety provisions
- The need to carry out regular maintenance when the screen display shows a "SERVICE" message

The installer must provide the user with all documentation relating to the Strata 1 boiler and any ancillary items.

23.2 To turn on the appliance

- 1 - Ensure the manometer indicates a pressure within the system of not less than 0.5bar.
- 2 - Ensure the gas supply is turned on.
- 3 - Switch on the on/off switch on the appliance control panel.

23.3 To turn off the appliance

- 1 - Switch off the on/off switch on the appliance control panel.
- 2 - Turn off the gas supply.

NOTE: Turning off the appliance will leave the system at risk of freezing during winter months and will put out of action the automatic pump exercising routine. If the only reason for shutdown is that normal heating is not required, then it is recommended to leave the boiler on and turn off or turn down any external controls.

STRATA



A member of the Modular Heating Group Plc

35 Nobel Square, Burnt Mills Industrial Estate, Basildon, Essex SS13 1LT Tel: 01268 591010 Fax: 01268 728202
<http://www.modular-heating-group.co.uk>

This publication is issued subject to alteration or withdrawal without notice.
The illustrations and specifications are not binding in detail. All offers and sales are subject to the Company's current terms and conditions of sale.