





OM-244 596J

2011-12

**Processes**

-  MIG (GMAW) Welding
-  Flux Cored (FCAW) Welding

**Description**



Wire Feeder

# SuitCase<sup>®</sup>

# X-TREME<sup>™</sup> 8 OS

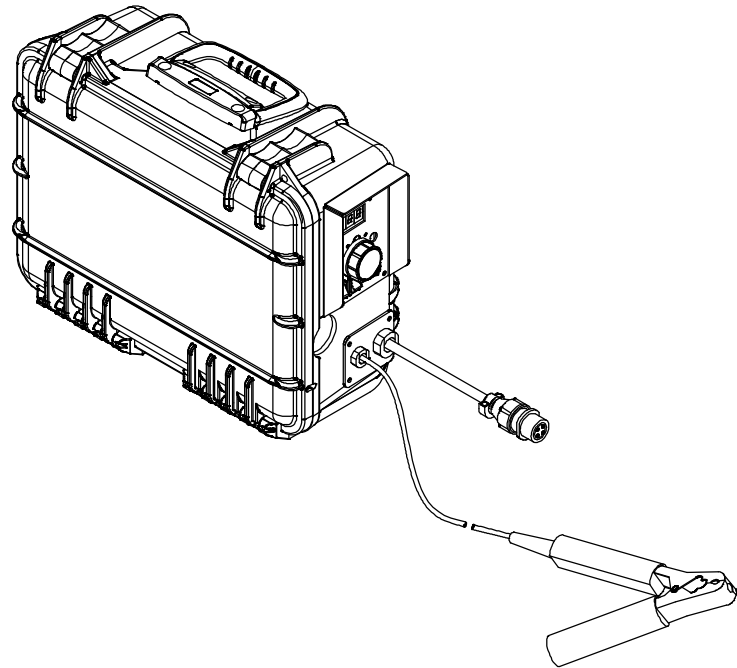

Visit our website at  
[www.MillerWelds.com](http://www.MillerWelds.com)

## OWNER'S MANUAL

File: MIG (GMAW)



# From Miller to You

---

*Thank you and congratulations* on choosing Miller. Now you can get the job done and get it done right. We know you don't have time to do it any other way.

That's why when Niels Miller first started building arc welders in 1929, he made sure his products offered long-lasting value and superior quality. Like you, his customers couldn't afford anything less. Miller products had to be more than the best they could be. They had to be the best you could buy.

Today, the people that build and sell Miller products continue the tradition. They're just as committed to providing equipment and service that meets the high standards of quality and value established in 1929.

This Owner's Manual is designed to help you get the most out of your Miller products. Please take time to read the Safety precautions. They will help you protect yourself against potential hazards on the worksite.

We've made installation and operation quick and easy. With Miller you can count on years of reliable service with proper maintenance. And if for some reason the unit needs repair, there's a Troubleshooting section that will help you figure out what the problem is. The parts list will then help you to decide the exact part you may need to fix the problem. Warranty and service information for your particular model are also provided.



Miller is the first welding equipment manufacturer in the U.S.A. to be registered to the ISO 9001 Quality System Standard.



Miller Electric manufactures a full line of welders and welding related equipment. For information on other quality Miller products, contact your local Miller distributor to receive the latest full line catalog or individual specification sheets. **To locate your nearest distributor or service agency call 1-800-4-A-Miller, or visit us at [www.MillerWelds.com](http://www.MillerWelds.com) on the web.**



Working as hard as you do – every power source from Miller is backed by the most hassle-free warranty in the business.



# TABLE OF CONTENTS

<b>SECTION 1 – SAFETY PRECAUTIONS - READ BEFORE USING</b> .....	<b>1</b>
1-1. Symbol Usage .....	1
1-2. Arc Welding Hazards .....	1
1-3. Additional Symbols For Installation, Operation, And Maintenance .....	3
1-4. California Proposition 65 Warnings .....	4
1-5. Principal Safety Standards .....	4
1-6. EMF Information .....	4
<b>SECTION 2 – CONSIGNES DE SÉCURITÉ – LIRE AVANT UTILISATION</b> .....	<b>5</b>
2-1. Symboles utilisés .....	5
2-2. Dangers relatifs au soudage à l'arc .....	5
2-3. Dangers supplémentaires en relation avec l'installation, le fonctionnement et la maintenance .....	7
2-4. Proposition californienne 65 Avertissements .....	8
2-5. Principales normes de sécurité .....	9
2-6. Informations relatives aux CEM .....	9
<b>SECTION 3 – DEFINITIONS</b> .....	<b>11</b>
3-1. Symbols And Definitions .....	11
<b>SECTION 4 – INSTALLATION</b> .....	<b>12</b>
4-1. Serial Number And Rating Label Location .....	12
4-2. Specifications .....	12
4-3. Gun Recommendation Table .....	12
4-4. Equipment Connection Diagram .....	12
4-5. Installing And Aligning Wire Guide And Drive Rolls .....	13
4-6. Connecting Welding Gun And Voltage Sensing Clamp .....	14
4-7. Connecting Shielding Gas .....	15
4-8. Connecting Weld Cable .....	15
4-9. Weld Output Terminals And Selecting Cable Sizes* .....	16
4-10. Installing And Threading Welding Wire .....	17
4-11. Display Board (PC20) DIP Switch Settings .....	18
<b>SECTION 5 – OPERATION</b> .....	<b>19</b>
5-1. Controls With Meters .....	19
5-2. Gun Consumables Information .....	20
<b>SECTION 6 – MAINTENANCE &amp; TROUBLESHOOTING</b> .....	<b>21</b>
6-1. Routine Maintenance .....	21
6-2. Overload Protection And Thermostat Protection .....	21
6-3. Troubleshooting .....	22
6-4. Diagnostics .....	23
<b>SECTION 7 – ELECTRICAL DIAGRAM</b> .....	<b>24</b>
<b>SECTION 8 – PARTS LIST</b> .....	<b>26</b>
<b>WARRANTY</b>	



# SECTION 1 – SAFETY PRECAUTIONS - READ BEFORE USING

som 2011–10

 Protect yourself and others from injury — read, follow, and save these important safety precautions and operating instructions.

## 1-1. Symbol Usage



**DANGER!** – Indicates a hazardous situation which, if not avoided, will result in death or serious injury. The possible hazards are shown in the adjoining symbols or explained in the text.



Indicates a hazardous situation which, if not avoided, could result in death or serious injury. The possible hazards are shown in the adjoining symbols or explained in the text.

**NOTICE** – Indicates statements not related to personal injury.

 Indicates special instructions.



This group of symbols means Warning! Watch Out! ELECTRIC SHOCK, MOVING PARTS, and HOT PARTS hazards. Consult symbols and related instructions below for necessary actions to avoid the hazards.

## 1-2. Arc Welding Hazards



The symbols shown below are used throughout this manual to call attention to and identify possible hazards. When you see the symbol, watch out, and follow the related instructions to avoid the hazard. The safety information given below is only a summary of the more complete safety information found in the Safety Standards listed in Section 1-5. Read and follow all Safety Standards.



Only qualified persons should install, operate, maintain, and repair this unit.



During operation, keep everybody, especially children, away.



### ELECTRIC SHOCK can kill.

Touching live electrical parts can cause fatal shocks or severe burns. The electrode and work circuit is electrically live whenever the output is on. The input power circuit and machine internal circuits are also live when power is on. In semiautomatic or automatic wire welding, the wire, wire reel, drive roll housing, and all metal parts touching the welding wire are electrically live. Incorrectly installed or improperly grounded equipment is a hazard.

- Do not touch live electrical parts.

- Wear dry, hole-free insulating gloves and body protection.
- Insulate yourself from work and ground using dry insulating mats or covers big enough to prevent any physical contact with the work or ground.
- Do not use AC output in damp areas, if movement is confined, or if there is a danger of falling.
- Use AC output ONLY if required for the welding process.
- If AC output is required, use remote output control if present on unit.
- Additional safety precautions are required when any of the following electrically hazardous conditions are present: in damp locations or while wearing wet clothing; on metal structures such as floors, gratings, or scaffolds; when in cramped positions such as sitting, kneeling, or lying; or when there is a high risk of unavoidable or accidental contact with the workpiece or ground. For these conditions, use the following equipment in order presented: 1) a semiautomatic DC constant voltage (wire) welder, 2) a DC manual (stick) welder, or 3) an AC welder with reduced open-circuit voltage. In most situations, use of a DC, constant voltage wire welder is recommended. And, do not work alone!
- Disconnect input power or stop engine before installing or servicing this equipment. Lockout/tagout input power according to OSHA 29 CFR 1910.147 (see Safety Standards).
- Properly install, ground, and operate this equipment according to its Owner's Manual and national, state, and local codes.

- Always verify the supply ground – check and be sure that input power cord ground wire is properly connected to ground terminal in disconnect box or that cord plug is connected to a properly grounded receptacle outlet.
- When making input connections, attach proper grounding conductor first – double-check connections.
- Keep cords dry, free of oil and grease, and protected from hot metal and sparks.
- Frequently inspect input power cord for damage or bare wiring – replace cord immediately if damaged – bare wiring can kill.
- Turn off all equipment when not in use.
- Do not use worn, damaged, undersized, or poorly spliced cables.
- Do not drape cables over your body.
- If earth grounding of the workpiece is required, ground it directly with a separate cable.
- Do not touch electrode if you are in contact with the work, ground, or another electrode from a different machine.
- Do not touch electrode holders connected to two welding machines at the same time since double open-circuit voltage will be present.
- Use only well-maintained equipment. Repair or replace damaged parts at once. Maintain unit according to manual.
- Wear a safety harness if working above floor level.
- Keep all panels and covers securely in place.
- Clamp work cable with good metal-to-metal contact to workpiece or worktable as near the weld as practical.
- Insulate work clamp when not connected to workpiece to prevent contact with any metal object.
- Do not connect more than one electrode or work cable to any single weld output terminal. Disconnect cable for process not in use.

### SIGNIFICANT DC VOLTAGE exists in inverter welding power sources AFTER removal of input power.

- Turn Off inverter, disconnect input power, and discharge input capacitors according to instructions in Maintenance Section before touching any parts.



### HOT PARTS can burn.

- Do not touch hot parts bare handed.
- Allow cooling period before working on equipment.
- To handle hot parts, use proper tools and/or wear heavy, insulated welding gloves and clothing to prevent burns.



### FUMES AND GASES can be hazardous.

Welding produces fumes and gases. Breathing these fumes and gases can be hazardous to your health.

- Keep your head out of the fumes. Do not breathe the fumes.
- If inside, ventilate the area and/or use local forced ventilation at the arc to remove welding fumes and gases.
- If ventilation is poor, wear an approved air-supplied respirator.
- Read and understand the Material Safety Data Sheets (MSDSs) and the manufacturer's instructions for metals, consumables, coatings, cleaners, and degreasers.
- Work in a confined space only if it is well ventilated, or while wearing an air-supplied respirator. Always have a trained watch-person nearby. Welding fumes and gases can displace air and lower the oxygen level causing injury or death. Be sure the breathing air is safe.
- Do not weld in locations near degreasing, cleaning, or spraying operations. The heat and rays of the arc can react with vapors to form highly toxic and irritating gases.
- Do not weld on coated metals, such as galvanized, lead, or cadmium plated steel, unless the coating is removed from the weld area, the area is well ventilated, and while wearing an air-supplied respirator. The coatings and any metals containing these elements can give off toxic fumes if welded.



### ARC RAYS can burn eyes and skin.

Arc rays from the welding process produce intense visible and invisible (ultraviolet and infrared) rays that can burn eyes and skin. Sparks fly off from the weld.

- Wear an approved welding helmet fitted with a proper shade of filter lenses to protect your face and eyes from arc rays and sparks when welding or watching (see ANSI Z49.1 and Z87.1 listed in Safety Standards).
- Wear approved safety glasses with side shields under your helmet.
- Use protective screens or barriers to protect others from flash, glare and sparks; warn others not to watch the arc.
- Wear protective clothing made from durable, flame-resistant material (leather, heavy cotton, or wool) and foot protection.



### WELDING can cause fire or explosion.

Welding on closed containers, such as tanks, drums, or pipes, can cause them to blow up. Sparks can fly off from the welding arc. The flying sparks, hot workpiece, and hot equipment can cause fires and burns. Accidental contact of electrode to metal objects can cause sparks, explosion, overheating, or fire. Check and be sure the area is safe before doing any welding.

- Remove all flammables within 35 ft (10.7 m) of the welding arc. If this is not possible, tightly cover them with approved covers.
- Do not weld where flying sparks can strike flammable material.
- Protect yourself and others from flying sparks and hot metal.
- Be alert that welding sparks and hot materials from welding can easily go through small cracks and openings to adjacent areas.
- Watch for fire, and keep a fire extinguisher nearby.
- Be aware that welding on a ceiling, floor, bulkhead, or partition can cause fire on the hidden side.
- Do not weld on containers that have held combustibles, or on closed containers such as tanks, drums, or pipes unless they are properly prepared according to AWS F4.1 and AWS A6.0 (see Safety Standards).
- Do not weld where the atmosphere may contain flammable dust, gas, or liquid vapors (such as gasoline).
- Connect work cable to the work as close to the welding area as practical to prevent welding current from traveling long, possibly unknown paths and causing electric shock, sparks, and fire hazards.
- Do not use welder to thaw frozen pipes.

- Remove stick electrode from holder or cut off welding wire at contact tip when not in use.
- Wear oil-free protective garments such as leather gloves, heavy shirt, cuffless trousers, high shoes, and a cap.
- Remove any combustibles, such as a butane lighter or matches, from your person before doing any welding.
- After completion of work, inspect area to ensure it is free of sparks, glowing embers, and flames.
- Use only correct fuses or circuit breakers. Do not oversize or bypass them.
- Follow requirements in OSHA 1910.252 (a) (2) (iv) and NFPA 51B for hot work and have a fire watcher and extinguisher nearby.

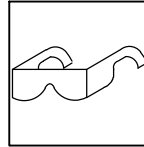

### FLYING METAL or DIRT can injure eyes.

- Welding, chipping, wire brushing, and grinding cause sparks and flying metal. As welds cool, they can throw off slag.
- Wear approved safety glasses with side shields even under your welding helmet.



### BUILDUP OF GAS can injure or kill.

- Shut off compressed gas supply when not in use.
- Always ventilate confined spaces or use approved air-supplied respirator.

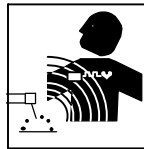

### ELECTRIC AND MAGNETIC FIELDS (EMF) can affect Implanted Medical Devices.

- Wearers of Pacemakers and other Implanted Medical Devices should keep away.
- Implanted Medical Device wearers should consult their doctor and the device manufacturer before going near arc welding, spot welding, gouging, plasma arc cutting, or induction heating operations.

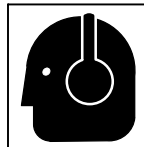

### NOISE can damage hearing.

Noise from some processes or equipment can damage hearing.

- Wear approved ear protection if noise level is high.

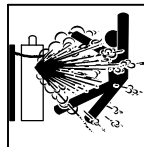

### CYLINDERS can explode if damaged.

Compressed gas cylinders contain gas under high pressure. If damaged, a cylinder can explode. Since gas cylinders are normally part of the welding process, be sure to treat them carefully.

- Protect compressed gas cylinders from excessive heat, mechanical shocks, physical damage, slag, open flames, sparks, and arcs.
- Install cylinders in an upright position by securing to a stationary support or cylinder rack to prevent falling or tipping.
- Keep cylinders away from any welding or other electrical circuits.
- Never drape a welding torch over a gas cylinder.
- Never allow a welding electrode to touch any cylinder.
- Never weld on a pressurized cylinder – explosion will result.
- Use only correct compressed gas cylinders, regulators, hoses, and fittings designed for the specific application; maintain them and associated parts in good condition.
- Turn face away from valve outlet when opening cylinder valve.
- Keep protective cap in place over valve except when cylinder is in use or connected for use.
- Use the right equipment, correct procedures, and sufficient number of persons to lift and move cylinders.
- Read and follow instructions on compressed gas cylinders, associated equipment, and Compressed Gas Association (CGA) publication P-1 listed in Safety Standards.

## 1-3. Additional Symbols For Installation, Operation, And Maintenance



### FIRE OR EXPLOSION hazard.

- Do not install or place unit on, over, or near combustible surfaces.
- Do not install unit near flammables.
- Do not overload building wiring – be sure power supply system is properly sized, rated, and protected to handle this unit.



### FALLING EQUIPMENT can injure.

- Use lifting eye to lift unit only, NOT running gear, gas cylinders, or any other accessories.
- Use equipment of adequate capacity to lift and support unit.
- If using lift forks to move unit, be sure forks are long enough to extend beyond opposite side of unit.
- Keep equipment (cables and cords) away from moving vehicles when working from an aerial location.
- Follow the guidelines in the Applications Manual for the Revised NIOSH Lifting Equation (Publication No. 94-110) when manually lifting heavy parts or equipment.

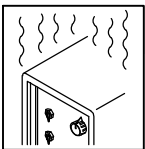

### OVERUSE can cause OVERHEATING

- Allow cooling period; follow rated duty cycle.
- Reduce current or reduce duty cycle before starting to weld again.
- Do not block or filter airflow to unit.

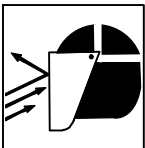

### FLYING SPARKS can injure.

- Wear a face shield to protect eyes and face.
- Shape tungsten electrode only on grinder with proper guards in a safe location wearing proper face, hand, and body protection.
- Sparks can cause fires — keep flammables away.

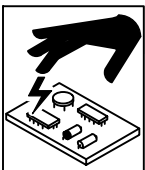

### STATIC (ESD) can damage PC boards.

- Put on grounded wrist strap BEFORE handling boards or parts.
- Use proper static-proof bags and boxes to store, move, or ship PC boards.



### MOVING PARTS can injure.

- Keep away from moving parts.
- Keep away from pinch points such as drive rolls.



### WELDING WIRE can injure.

- Do not press gun trigger until instructed to do so.
- Do not point gun toward any part of the body, other people, or any metal when threading welding wire.

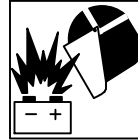

### BATTERY EXPLOSION can injure.

- Do not use welder to charge batteries or jump start vehicles unless it has a battery charging feature designed for this purpose.



### MOVING PARTS can injure.

- Keep away from moving parts such as fans.
- Keep all doors, panels, covers, and guards closed and securely in place.
- Have only qualified persons remove doors, panels, covers, or guards for maintenance and troubleshooting as necessary.
- Reinstall doors, panels, covers, or guards when maintenance is finished and before reconnecting input power.

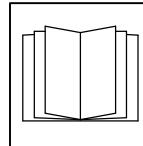

### READ INSTRUCTIONS.

- Read and follow all labels and the Owner's Manual carefully before installing, operating, or servicing unit. Read the safety information at the beginning of the manual and in each section.
- Use only genuine replacement parts from the manufacturer.
- Perform maintenance and service according to the Owner's Manuals, industry standards, and national, state, and local codes.

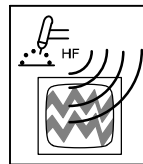

### H.F. RADIATION can cause interference.

- High-frequency (H.F.) can interfere with radio navigation, safety services, computers, and communications equipment.
- Have only qualified persons familiar with electronic equipment perform this installation.
- The user is responsible for having a qualified electrician promptly correct any interference problem resulting from the installation.
- If notified by the FCC about interference, stop using the equipment at once.
- Have the installation regularly checked and maintained.
- Keep high-frequency source doors and panels tightly shut, keep spark gaps at correct setting, and use grounding and shielding to minimize the possibility of interference.

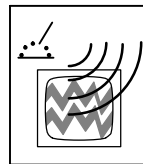

### ARC WELDING can cause interference.

- Electromagnetic energy can interfere with sensitive electronic equipment such as computers and computer-driven equipment such as robots.
- Be sure all equipment in the welding area is electromagnetically compatible.
- To reduce possible interference, keep weld cables as short as possible, close together, and down low, such as on the floor.
- Locate welding operation 100 meters from any sensitive electronic equipment.
- Be sure this welding machine is installed and grounded according to this manual.
- If interference still occurs, the user must take extra measures such as moving the welding machine, using shielded cables, using line filters, or shielding the work area.

## 1-4. California Proposition 65 Warnings

 **Welding or cutting equipment produces fumes or gases which contain chemicals known to the State of California to cause birth defects and, in some cases, cancer. (California Health & Safety Code Section 25249.5 et seq.)**

 **This product contains chemicals, including lead, known to the state of California to cause cancer, birth defects, or other reproductive harm. *Wash hands after use.***

## 1-5. Principal Safety Standards

*Safety in Welding, Cutting, and Allied Processes*, ANSI Standard Z49.1, is available as a free download from the American Welding Society at <http://www.aws.org> or purchased from Global Engineering Documents (phone: 1-877-413-5184, website: [www.global.ihs.com](http://www.global.ihs.com)).

*Safe Practices for the Preparation of Containers and Piping for Welding and Cutting*, American Welding Society Standard AWS F4.1, from Global Engineering Documents (phone: 1-877-413-5184, website: [www.global.ihs.com](http://www.global.ihs.com)).

*Safe Practices for Welding and Cutting Containers that have Held Combustibles*, American Welding Society Standard AWS A6.0, from Global Engineering Documents (phone: 1-877-413-5184, website: [www.global.ihs.com](http://www.global.ihs.com)).

*National Electrical Code*, NFPA Standard 70, from National Fire Protection Association, Quincy, MA 02269 (phone: 1-800-344-3555, website: [www.nfpa.org](http://www.nfpa.org) and [www.sparky.org](http://www.sparky.org)).

*Safe Handling of Compressed Gases in Cylinders*, CGA Pamphlet P-1, from Compressed Gas Association, 14501 George Carter Way, Suite 103, Chantilly, VA 20151 (phone: 703-788-2700, website: [www.cganet.com](http://www.cganet.com)).

*Safety in Welding, Cutting, and Allied Processes*, CSA Standard W117.2, from Canadian Standards Association, Standards Sales, 5060

Spectrum Way, Suite 100, Ontario, Canada L4W 5NS (phone: 800-463-6727, website: [www.csa-international.org](http://www.csa-international.org)).

*Safe Practice For Occupational And Educational Eye And Face Protection*, ANSI Standard Z87.1, from American National Standards Institute, 25 West 43rd Street, New York, NY 10036 (phone: 212-642-4900, website: [www.ansi.org](http://www.ansi.org)).

*Standard for Fire Prevention During Welding, Cutting, and Other Hot Work*, NFPA Standard 51B, from National Fire Protection Association, Quincy, MA 02269 (phone: 1-800-344-3555, website: [www.nfpa.org](http://www.nfpa.org)).

OSHA, Occupational Safety and Health Standards for General Industry, Title 29, Code of Federal Regulations (CFR), Part 1910, Subpart Q, and Part 1926, Subpart J, from U.S. Government Printing Office, Superintendent of Documents, P.O. Box 371954, Pittsburgh, PA 15250-7954 (phone: 1-866-512-1800) (there are 10 OSHA Regional Offices—phone for Region 5, Chicago, is 312-353-2220, website: [www.osha.gov](http://www.osha.gov)).

*Applications Manual for the Revised NIOSH Lifting Equation*, The National Institute for Occupational Safety and Health (NIOSH), 1600 Clifton Rd, Atlanta, GA 30333 (phone: 1-800-232-4636, website: [www.cdc.gov/NIOSH](http://www.cdc.gov/NIOSH)).

## 1-6. EMF Information

Electric current flowing through any conductor causes localized electric and magnetic fields (EMF). Welding current creates an EMF field around the welding circuit and welding equipment. EMF fields may interfere with some medical implants, e.g. pacemakers. Protective measures for persons wearing medical implants have to be taken. For example, restrict access for passers—by or conduct individual risk assessment for welders. All welders should use the following procedures in order to minimize exposure to EMF fields from the welding circuit:

1. Keep cables close together by twisting or taping them, or using a cable cover.
2. Do not place your body between welding cables. Arrange cables to one side and away from the operator.
3. Do not coil or drape cables around your body.

4. Keep head and trunk as far away from the equipment in the welding circuit as possible.
5. Connect work clamp to workpiece as close to the weld as possible.
6. Do not work next to, sit or lean on the welding power source.
7. Do not weld whilst carrying the welding power source or wire feeder.

### **About Implanted Medical Devices:**

Implanted Medical Device wearers should consult their doctor and the device manufacturer before performing or going near arc welding, spot welding, gouging, plasma arc cutting, or induction heating operations. If cleared by your doctor, then following the above procedures is recommended.



# SECTION 2 – CONSIGNES DE SÉCURITÉ – LIRE AVANT UTILISATION

fre\_som\_2011-10

**!** Pour écarter les risques de blessure pour vous-même et pour autrui — lire, appliquer et ranger en lieu sûr ces consignes relatives aux précautions de sécurité et au mode opératoire.

## 2-1. Symboles utilisés



**DANGER!** – Indique une situation dangereuse qui si on l'évite pas peut donner la mort ou des blessures graves. Les dangers possibles sont montrés par les symboles joints ou sont expliqués dans le texte.



Indique une situation dangereuse qui si on l'évite pas peut donner la mort ou des blessures graves. Les dangers possibles sont montrés par les symboles joints ou sont expliqués dans le texte.

**NOTE** – Indique des déclarations pas en relation avec des blessures personnelles.

 Indique des instructions spécifiques.



Ce groupe de symboles veut dire Avertissement! Attention! DANGER DE CHOC ELECTRIQUE, PIECES EN MOUVEMENT, et PIECES CHAUDES. Consulter les symboles et les instructions ci-dessous y afférant pour les actions nécessaires afin d'éviter le danger.

## 2-2. Dangers relatifs au soudage à l'arc



Les symboles représentés ci-dessous sont utilisés dans ce manuel pour attirer l'attention et identifier les dangers possibles. En présence de l'un de ces symboles, prendre garde et suivre les instructions afférentes pour éviter tout risque. Les instructions en matière de sécurité indiquées ci-dessous ne constituent qu'un sommaire des instructions de sécurité plus complètes fournies dans les normes de sécurité énumérées dans la Section 2-5. Lire et observer toutes les normes de sécurité.



Seul un personnel qualifié est autorisé à installer, faire fonctionner, entretenir et réparer cet appareil.



Pendant le fonctionnement, maintenir à distance toutes les personnes, notamment les enfants de l'appareil.

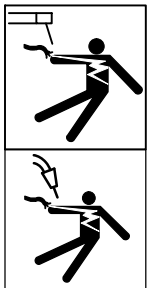

### UNE DÉCHARGE ÉLECTRIQUE peut entraîner la mort.

Le contact d'organes électriques sous tension peut provoquer des accidents mortels ou des brûlures graves. Le circuit de l'électrode et de la pièce est sous tension lorsque le courant est délivré à la sortie. Le circuit d'alimentation et les circuits internes de la machine sont également sous tension lorsque l'alimentation est sur Marche. Dans le mode de soudage avec du fil, le fil, le dérouleur, le bloc de commande du rouleau et toutes les parties métalliques en contact avec le fil sont sous tension électrique. Un équipement installé ou mis à la terre de manière incorrecte ou impropre constitue un danger.

- Ne pas toucher aux pièces électriques sous tension.
- Porter des gants isolants et des vêtements de protection secs et sans trous.
- S'isoler de la pièce à couper et du sol en utilisant des housses ou des tapis assez grands afin d'éviter tout contact physique avec la pièce à couper ou le sol.
- Ne pas se servir de source électrique à courant électrique dans les zones humides, dans les endroits confinés ou là où on risque de tomber.
- Se servir d'une source électrique à courant électrique UNIQUEMENT si le procédé de soudage le demande.
- Si l'utilisation d'une source électrique à courant électrique s'avère nécessaire, se servir de la fonction de télécommande si l'appareil en est équipé.
- D'autres consignes de sécurité sont nécessaires dans les conditions suivantes : risques électriques dans un environnement humide ou si l'on porte des vêtements mouillés ; sur des structures métalliques telles que sols, grilles ou échafaudages ; en position coincée comme assise, à genoux ou couchée ; ou s'il y a un risque élevé de contact inévitable ou accidentel avec la pièce à souder ou le sol. Dans ces conditions, utiliser les équipements suivants,

dans l'ordre indiqué : 1) un poste à souder DC à tension constante (à fil), 2) un poste à souder DC manuel (électrode) ou 3) un poste à souder AC à tension à vide réduite. Dans la plupart des situations, l'utilisation d'un poste à souder DC à fil à tension constante est recommandée. En outre, ne pas travailler seul !

- Couper l'alimentation ou arrêter le moteur avant de procéder à l'installation, à la réparation ou à l'entretien de l'appareil. Déverrouiller l'alimentation selon la norme OSHA 29 CFR 1910.147 (voir normes de sécurité).
- Installez, mettez à la terre et utilisez correctement cet équipement conformément à son Manuel d'Utilisation et aux réglementations nationales, gouvernementales et locales.
- Toujours vérifier la terre du cordon d'alimentation. Vérifier et s'assurer que le fil de terre du cordon d'alimentation est bien raccordé à la borne de terre du sectionneur ou que la fiche du cordon est raccordée à une prise correctement mise à la terre.
- En effectuant les raccordements d'entrée, fixer d'abord le conducteur de mise à la terre approprié et contre-vérifier les connexions.
- Les câbles doivent être exempts d'humidité, d'huile et de graisse; protégez-les contre les étincelles et les pièces métalliques chaudes.
- Vérifier fréquemment le cordon d'alimentation afin de s'assurer qu'il n'est pas altéré ou à nu, le remplacer immédiatement s'il l'est. Un fil à nu peut entraîner la mort.
- L'équipement doit être hors tension lorsqu'il n'est pas utilisé.
- Ne pas utiliser des câbles usés, endommagés, de grosseur insuffisante ou mal épissés.
- Ne pas enrouler les câbles autour du corps.
- Si la pièce soudée doit être mise à la terre, le faire directement avec un câble distinct.
- Ne pas toucher l'électrode quand on est en contact avec la pièce, la terre ou une électrode provenant d'une autre machine.
- Ne pas toucher des porte électrodes connectés à deux machines en même temps à cause de la présence d'une tension à vide doublée.
- N'utiliser qu'un matériel en bon état. Réparer ou remplacer sur-le-champ les pièces endommagées. Entretenir l'appareil conformément à ce manuel.
- Porter un harnais de sécurité si l'on doit travailler au-dessus du sol.
- S'assurer que tous les panneaux et couvercles sont correctement en place.
- Fixer le câble de retour de façon à obtenir un bon contact métal-métal avec la pièce à souder ou la table de travail, le plus près possible de la soudure.
- Isoler la pince de masse quand pas mis à la pièce pour éviter le contact avec tout objet métallique.
- Ne pas raccorder plus d'une électrode ou plus d'un câble de masse à une même borne de sortie de soudage. Débrancher le câble pour le procédé non utilisé.

## Il reste une TENSION DC NON NÉGLIGEABLE dans les sources de soudage onduleur UNE FOIS l'alimentation coupée.

- Arrêter les convertisseurs, débrancher le courant électrique et décharger les condensateurs d'alimentation selon les instructions indiquées dans la partie Entretien avant de toucher les pièces.



### LES PIÈCES CHAUDES peuvent provoquer des brûlures.

- Ne pas toucher à mains nues les parties chaudes.
- Prévoir une période de refroidissement avant de travailler à l'équipement.
- Ne pas toucher aux pièces chaudes, utiliser les outils recommandés et porter des gants de soudage et des vêtements épais pour éviter les brûlures.



### LES FUMÉES ET LES GAZ peuvent être dangereux.

Le soudage génère des fumées et des gaz. Leur inhalation peut être dangereux pour votre santé.

- Eloigner votre tête des fumées. Ne pas respirer les fumées.
- À l'intérieur, ventiler la zone et/ou utiliser une ventilation forcée au niveau de l'arc pour l'évacuation des fumées et des gaz de soudage.
- Si la ventilation est médiocre, porter un respirateur anti-vapeurs approuvé.
- Lire et comprendre les spécifications de sécurité des matériaux (MSDS) et les instructions du fabricant concernant les métaux, les consommables, les revêtements, les nettoyants et les dégraissants.
- Travailler dans un espace fermé seulement s'il est bien ventilé ou en portant un respirateur à alimentation d'air. Demander toujours à un surveillant dûment formé de se tenir à proximité. Des fumées et des gaz de soudage peuvent déplacer l'air et abaisser le niveau d'oxygène provoquant des blessures ou des accidents mortels. S'assurer que l'air de respiration ne présente aucun danger.
- Ne pas souder dans des endroits situés à proximité d'opérations de dégraissage, de nettoyage ou de pulvérisation. La chaleur et les rayons de l'arc peuvent réagir en présence de vapeurs et former des gaz hautement toxiques et irritants.
- Ne pas souder des métaux munis d'un revêtement, tels que l'acier galvanisé, plaqué en plomb ou au cadmium à moins que le revêtement n'ait été enlevé dans la zone de soudure, que l'endroit soit bien ventilé, et en portant un respirateur à alimentation d'air. Les revêtements et tous les métaux renfermant ces éléments peuvent dégager des fumées toxiques en cas de soudage.



### LES RAYONS DE L'ARC peuvent provoquer des brûlures dans les yeux et sur la peau.

Le rayonnement de l'arc du procédé de soudage génère des rayons visibles et invisibles intense (ultraviolets et infrarouges) susceptibles de provoquer des brûlures dans les yeux et sur la peau. Des étincelles sont projetées pendant le soudage.

- Porter un casque de soudage approuvé muni de verres filtrants appropriés pour protéger visage et yeux pour protéger votre visage et vos yeux pendant le soudage ou pour regarder (voir ANSI Z49.1 et Z87.1 énuméré dans les normes de sécurité).
- Porter des lunettes de sécurité avec écrans latéraux même sous votre casque.
- Avoir recours à des écrans protecteurs ou à des rideaux pour protéger les autres contre les rayonnements les éblouissements et les étincelles ; prévenir toute personne sur les lieux de ne pas regarder l'arc.
- Porter des vêtements confectionnés avec des matières résistantes et ignifuges (cuir, coton lourd ou laine) et des bottes de protection.



### LE SOUDAGE peut provoquer un incendie ou une explosion.

Le soudage effectué sur des conteneurs fermés tels que des réservoirs, tambours ou des conduites peut provoquer leur éclatement. Des étincelles peuvent être projetées de l'arc de soudage. La projection d'étincelles, des pièces chaudes et des équipements chauds peut provoquer des incendies et des brûlures. Le contact accidentel de l'électrode avec des objets métalliques peut provoquer des étincelles, une explosion, un surchauffement ou un incendie. Avant de commencer le soudage, vérifier et s'assurer que l'endroit ne présente pas de danger.

- Déplacer toutes les substances inflammables à une distance de 10,7 m de l'arc de soudage. En cas d'impossibilité les recouvrir soigneusement avec des protections homologués.
- Ne pas souder dans un endroit là où des étincelles peuvent tomber sur des substances inflammables.
- Se protéger et d'autres personnes de la projection d'étincelles et de métal chaud.
- Des étincelles et des matériaux chauds du soudage peuvent facilement passer dans d'autres zones en traversant de petites fissures et des ouvertures.
- Surveiller tout déclenchement d'incendie et tenir un extincteur à proximité.
- Le soudage effectué sur un plafond, plancher, paroi ou séparation peut déclencher un incendie de l'autre côté.
- Ne pas effectuer le soudage sur des conteneurs fermés tels que des réservoirs, tambours, ou conduites, à moins qu'ils n'aient été préparés correctement conformément à AWS F4.1 et AWS A6.0 (voir les Normes de Sécurité).
- Ne soudez pas si l'air ambiant est chargé de particules, gaz, ou vapeurs inflammables (vapeur d'essence, par exemple).
- Brancher le câble de masse sur la pièce le plus près possible de la zone de soudage pour éviter le transport du courant sur une longue distance par des chemins inconnus éventuels en provoquant des risques d'électrocution, d'étincelles et d'incendie.
- Ne pas utiliser le poste de soudage pour dégeler des conduites gelées.
- En cas de non utilisation, enlever la baguette d'électrode du porte-électrode ou couper le fil à la pointe de contact.
- Porter des vêtements de protection dépourvus d'huile tels que des gants en cuir, une chemise en matériau lourd, des pantalons sans revers, des chaussures hautes et un couvre chef.
- Avant de souder, retirer toute substance combustible de vos poches telles qu'un allumeur au butane ou des allumettes.
- Une fois le travail achevé, assurez-vous qu'il ne reste aucune trace d'étincelles incandescentes ni de flammes.
- Utiliser exclusivement des fusibles ou coupe-circuits appropriés. Ne pas augmenter leur puissance; ne pas les ponter.
- Une fois le travail achevé, assurez-vous qu'il ne reste aucune trace d'étincelles incandescentes ni de flammes.
- Utiliser exclusivement des fusibles ou coupe-circuits appropriés. Ne pas augmenter leur puissance; ne pas les ponter.
- Suivre les recommandations dans OSHA 1910.252(a)(2)(iv) et NFPA 51B pour les travaux à chaud et avoir de la surveillance et un extincteur à proximité.

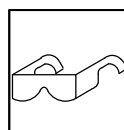

### DES PIÈCES DE METAL ou DES SALETES peuvent provoquer des blessures dans les yeux.

- Le soudage, l'écaillage, le passage de la pièce à la brosse en fil de fer, et le meulage génèrent des étincelles et des particules métalliques volantes. Pendant la période de refroidissement des soudures, elles risquent de projeter du laitier.
- Porter des lunettes de sécurité avec écrans latéraux ou un écran facial.



### LES ACCUMULATIONS DE GAZ risquent de provoquer des blessures ou même la mort.

- Fermer l'alimentation du gaz comprimé en cas de non utilisation.
- Veiller toujours à bien aérer les espaces confinés ou se servir d'un respirateur d'adduction d'air homologué.



### Les CHAMPS ÉLECTROMAGNÉTIQUES (CEM) peuvent affecter les implants médicaux.

- Les porteurs de stimulateurs cardiaques et autres implants médicaux doivent rester à distance.
- Les porteurs d'implants médicaux doivent consulter leur médecin et le fabricant du dispositif avant de s'approcher de la zone où se déroule du soudage à l'arc, du soudage par points, du gougeage, de la découpe plasma ou une opération de chauffage par induction.

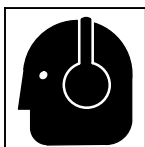

### LE BRUIT peut endommager l'ouïe.

Le bruit des processus et des équipements peut affecter l'ouïe.

- Porter des protections approuvées pour les oreilles si le niveau sonore est trop élevé.

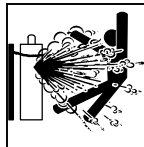

### LES BOUTEILLES peuvent exploser si elles sont endommagées.

Les bouteilles de gaz comprimé contiennent du gaz sous haute pression. Si une bouteille est endommagée, elle peut exploser. Du fait que les bouteilles de gaz font normalement partie du procédé de soudage, les manipuler avec précaution.

- Protéger les bouteilles de gaz comprimé d'une chaleur excessive, des chocs mécaniques, des dommages physiques, du laitier, des flammes ouvertes, des étincelles et des arcs.
- Placer les bouteilles debout en les fixant dans un support stationnaire ou dans un porte-bouteilles pour les empêcher de tomber ou de se renverser.
- Tenir les bouteilles éloignées des circuits de soudage ou autres circuits électriques.
- Ne jamais placer une torche de soudage sur une bouteille à gaz.
- Une électrode de soudage ne doit jamais entrer en contact avec une bouteille.
- Ne jamais souder une bouteille pressurisée – risque d'explosion.
- Utiliser seulement des bouteilles de gaz comprimé, régulateurs, tuyaux et raccords convenables pour cette application spécifique; les maintenir ainsi que les éléments associés en bon état.
- Détourner votre visage du détendeur-régulateur lorsque vous ouvrez la soupape de la bouteille.
- Le couvercle du détendeur doit toujours être en place, sauf lorsque la bouteille est utilisée ou qu'elle est reliée pour usage ultérieur.
- Utiliser les équipements corrects, les bonnes procédures et suffisamment de personnes pour soulever et déplacer les bouteilles.
- Lire et suivre les instructions sur les bouteilles de gaz comprimé, l'équipement connexe et le dépliant P-1 de la CGA (Compressed Gas Association) mentionné dans les principales normes de sécurité.

## 2-3. Dangers supplémentaires en relation avec l'installation, le fonctionnement et la maintenance



### Risque D'INCENDIE OU D'EXPLOSION.

- Ne pas placer l'appareil sur, au-dessus ou à proximité de surfaces inflammables.
- Ne pas installer l'appareil à proximité de produits inflammables.
- Ne pas surcharger l'installation électrique – s'assurer que l'alimentation est correctement dimensionnée et protégée avant de mettre l'appareil en service.

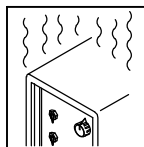

### L'EMPLOI EXCESSIF peut SURCHAUFFER L'ÉQUIPEMENT.

- Prévoir une période de refroidissement ; respecter le cycle opératoire nominal.
- Réduire le courant ou le facteur de marche avant de poursuivre le soudage.
- Ne pas obstruer les passages d'air du poste.

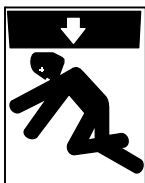

### LA CHUTE DE L'ÉQUIPEMENT peut provoquer des blessures.

- Utiliser l'anneau de levage uniquement pour soulever l'appareil, NON PAS les chariots, les bouteilles de gaz ou tout autre accessoire.
- Utiliser un équipement de levage de capacité suffisante pour lever l'appareil.
- En utilisant des fourches de levage pour déplacer l'unité, s'assurer que les fourches sont suffisamment longues pour dépasser du côté opposé de l'appareil.
- Tenir l'équipement (câbles et cordons) à distance des véhicules mobiles lors de toute opération en hauteur.
- Suivre les consignes du Manuel des applications pour l'équation de levage NIOSH révisée (Publication N°94-110) lors du levage manuel de pièces ou équipements lourds.

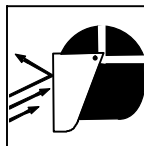

### LES ÉTINCELLES PROJETÉES peuvent provoquer des blessures.

- Porter un écran facial pour protéger le visage et les yeux.
- Affûter l'électrode au tungstène uniquement à la meuleuse dotée de protecteurs. Cette manœuvre est à exécuter dans un endroit sûr lorsque l'on porte l'équipement homologué de protection du visage, des mains et du corps.
- Les étincelles risquent de causer un incendie – éloigner toute substance inflammable.

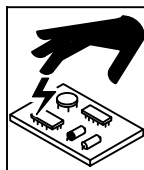

### LES CHARGES ÉLECTROSTATIQUES peuvent endommager les circuits imprimés.

- Établir la connexion avec la barrette de terre avant de manipuler des cartes ou des pièces.
- Utiliser des pochettes et des boîtes antistatiques pour stocker, déplacer ou expédier des cartes de circuits imprimés.



### Les PIÈCES MOBILES peuvent causer des blessures.

- Ne pas s'approcher des organes mobiles.
- Ne pas s'approcher des points de coincement tels que des rouleaux de commande.



### LES FILS DE SOUDAGE peuvent provoquer des blessures.

- Ne pas appuyer sur la gâchette avant d'en avoir reçu l'instruction.
- Ne pas diriger le pistolet vers soi, d'autres personnes ou toute pièce mécanique en engageant le fil de soudage.



### L'EXPLOSION DE LA BATTERIE peut provoquer des blessures.

- Ne pas utiliser l'appareil de soudage pour charger des batteries ou faire démarrer des véhicules à l'aide de câbles de démarrage, sauf si l'appareil dispose d'une fonctionnalité de charge de batterie destinée à cet usage.



### Les PIÈCES MOBILES peuvent causer des blessures.

- S'abstenir de toucher des organes mobiles tels que des ventilateurs.
- Maintenir fermés et verrouillés les portes, panneaux, recouvrements et dispositifs de protection.
- Lorsque cela est nécessaire pour des travaux d'entretien et de dépannage, faire retirer les portes, panneaux, recouvrements ou dispositifs de protection uniquement par du personnel qualifié.
- Remettre les portes, panneaux, recouvrements ou dispositifs de protection quand l'entretien est terminé et avant de rebrancher l'alimentation électrique.

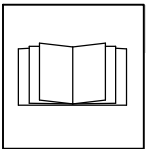

### LIRE LES INSTRUCTIONS.

- Lire et appliquer les instructions sur les étiquettes et le Mode d'emploi avant l'installation, l'utilisation ou l'entretien de l'appareil. Lire les informations de sécurité au début du manuel et dans chaque section.
- N'utiliser que les pièces de rechange recommandées par le constructeur.
- Effectuer l'entretien en respectant les manuels d'utilisation, les normes industrielles et les codes nationaux, d'état et locaux.

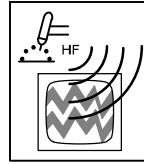

### LE RAYONNEMENT HAUTE FRÉQUENCE (H.F.) risque de provoquer des interférences.

- Le rayonnement haute fréquence (H.F.) peut provoquer des interférences avec les équipements de radio-navigation et de communication, les services de sécurité et les ordinateurs.

- Demander seulement à des personnes qualifiées familiarisées avec des équipements électroniques de faire fonctionner l'installation.
- L'utilisateur est tenu de faire corriger rapidement par un électricien qualifié les interférences résultant de l'installation.
- Si le FCC signale des interférences, arrêter immédiatement l'appareil.
- Effectuer régulièrement le contrôle et l'entretien de l'installation.
- Maintenir soigneusement fermés les portes et les panneaux des sources de haute fréquence, maintenir les éclateurs à une distance correcte et utiliser une terre et un blindage pour réduire les interférences éventuelles.

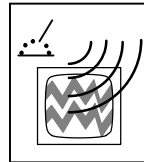

### LE SOUDAGE À L'ARC risque de provoquer des interférences.

- L'énergie électromagnétique risque de provoquer des interférences pour l'équipement électronique sensible tel que les ordinateurs et l'équipement commandé par ordinateur tel que les robots.
- Veiller à ce que tout l'équipement de la zone de soudage soit compatible électromagnétiquement.
- Pour réduire la possibilité d'interférence, maintenir les câbles de soudage aussi courts que possible, les grouper, et les poser aussi bas que possible (ex. par terre).
- Veiller à souder à une distance de 100 mètres de tout équipement électronique sensible.
- Veiller à ce que ce poste de soudage soit posé et mis à la terre conformément à ce mode d'emploi.
- En cas d'interférences après avoir pris les mesures précédentes, il incombe à l'utilisateur de prendre des mesures supplémentaires telles que le déplacement du poste, l'utilisation de câbles blindés, l'utilisation de filtres de ligne ou la pose de protecteurs dans la zone de travail.

## 2-4. Proposition californienne 65 Avertissements

**!** Les équipements de soudage et de coupage produisent des fumées et des gaz qui contiennent des produits chimiques dont l'État de Californie reconnaît qu'ils provoquent des malformations congénitales et, dans certains cas, des cancers. (Code de santé et de sécurité de Californie, chapitre 25249.5 et suivants)

**!** Ce produit contient des produits chimiques, notamment du plomb, dont l'État de Californie reconnaît qu'ils provoquent des cancers, des malformations congénitales ou d'autres problèmes de procréation. *Se laver les mains après utilisation.*

## 2-5. Principales normes de sécurité

*Safety in Welding, Cutting, and Allied Processes*, ANSI Standard Z49.1, is available as a free download from the American Welding Society at <http://www.aws.org> or purchased from Global Engineering Documents (phone: 1-877-413-5184, website: [www.global.ihs.com](http://www.global.ihs.com)).

*Safe Practices for the Preparation of Containers and Piping for Welding and Cutting*, American Welding Society Standard AWS F4.1, from Global Engineering Documents (phone: 1-877-413-5184, website: [www.global.ihs.com](http://www.global.ihs.com)).

*Safe Practices for Welding and Cutting Containers that have Held Combustibles*, American Welding Society Standard AWS A6.0, from Global Engineering Documents (phone: 1-877-413-5184, website: [www.global.ihs.com](http://www.global.ihs.com)).

*National Electrical Code*, NFPA Standard 70, from National Fire Protection Association, Quincy, MA 02269 (phone: 1-800-344-3555, website: [www.nfpa.org](http://www.nfpa.org) and [www.sparky.org](http://www.sparky.org)).

*Safe Handling of Compressed Gases in Cylinders*, CGA Pamphlet P-1, from Compressed Gas Association, 14501 George Carter Way, Suite 103, Chantilly, VA 20151 (phone: 703-788-2700, website: [www.cganet.com](http://www.cganet.com)).

*Safety in Welding, Cutting, and Allied Processes*, CSA Standard W117.2, from Canadian Standards Association, Standards Sales, 5060

Spectrum Way, Suite 100, Ontario, Canada L4W 5NS (phone: 800-463-6727, website: [www.csa-international.org](http://www.csa-international.org)).

*Safe Practice For Occupational And Educational Eye And Face Protection*, ANSI Standard Z87.1, from American National Standards Institute, 25 West 43rd Street, New York, NY 10036 (phone: 212-642-4900, website: [www.ansi.org](http://www.ansi.org)).

*Standard for Fire Prevention During Welding, Cutting, and Other Hot Work*, NFPA Standard 51B, from National Fire Protection Association, Quincy, MA 02269 (phone: 1-800-344-3555, website: [www.nfpa.org](http://www.nfpa.org)).

OSHA, Occupational Safety and Health Standards for General Industry, Title 29, Code of Federal Regulations (CFR), Part 1910, Subpart Q, and Part 1926, Subpart J, from U.S. Government Printing Office, Superintendent of Documents, P.O. Box 371954, Pittsburgh, PA 15250-7954 (phone: 1-866-512-1800) (there are 10 OSHA Regional Offices—phone for Region 5, Chicago, is 312-353-2220, website: [www.osha.gov](http://www.osha.gov)).

*Applications Manual for the Revised NIOSH Lifting Equation*, The National Institute for Occupational Safety and Health (NIOSH), 1600 Clifton Rd, Atlanta, GA 30333 (phone: 1-800-232-4636, website: [www.cdc.gov/NIOSH](http://www.cdc.gov/NIOSH)).

## 2-6. Informations relatives aux CEM

Le courant électrique qui traverse tout conducteur génère des champs électromagnétiques (CEM) à certains endroits. Le courant de soudage crée un CEM autour du circuit et du matériel de soudage. Les CEM peuvent créer des interférences avec certains implants médicaux comme des stimulateurs cardiaques. Des mesures de protection pour les porteurs d'implants médicaux doivent être prises: Limiter par exemple tout accès aux passants ou procéder à une évaluation des risques individuels pour les soudeurs. Tous les soudeurs doivent appliquer les procédures suivantes pour minimiser l'exposition aux CEM provenant du circuit de soudage:

1. Rassembler les câbles en les torsadant ou en les attachant avec du ruban adhésif ou avec une housse.
2. Ne pas se tenir au milieu des câbles de soudage. Disposer les câbles d'un côté et à distance de l'opérateur.
3. Ne pas courber et ne pas entourer les câbles autour de votre corps.

4. Maintenir la tête et le torse aussi loin que possible du matériel du circuit de soudage.
5. Connecter la pince sur la pièce aussi près que possible de la soudure.
6. Ne pas travailler à proximité d'une source de soudage, ni s'asseoir ou se pencher dessus.
7. Ne pas souder tout en portant la source de soudage ou le dévidoir.

### En ce qui concerne les implants médicaux :

Les porteurs d'implants doivent d'abord consulter leur médecin avant de s'approcher des opérations de soudage à l'arc, de soudage par points, de gougeage, du coupage plasma ou de chauffage par induction. Si le médecin approuve, il est recommandé de suivre les procédures précédentes.





# SECTION 4 – INSTALLATION

## 4-1. Serial Number And Rating Label Location

The serial number and rating information for this product is located inside the cover. Use rating label to determine input power requirements and/or rated output. For future reference, write serial number in space provided on back cover of this manual.

## 4-2. Specifications

Type of Input Power	Welding Power Source Type	Wire Feed Speed Range	Wire Diameter Range	Input Welding Circuit Rating	IP Rating	Max. Wire Spool Capacity	Overall Dimensions	Weight
Open-Circuit/ Arc Voltage, 14 – 110 Volts DC	Constant Voltage (CV) Or Constant Current (CC) DC Power Source Only	25 – 780 ipm (1.3 – 19.8 mpm) Depending On Arc Voltage	*Solid Steel: .023 – 5/64 in. (0.6 – 2.0 mm); Stainless Steel: .023 – .052 in. (0.6 – 1.3 mm); Flux Cored: .030 – 5/64 in. (0.8 – 2.0 mm)	330 Amperes At 60% Duty Cycle	23	10 lb (4.5 kg), 8 in. (203 mm)	Length: 18 in. (457 mm) Width: 7-1/4 in. (184 mm) Height: 12-3/4 in. (324 mm)	30 lb (13.6 kg)

\*Maximum gun length is 10 ft. for solid steel .062 in. wire.

## 4-3. Gun Recommendation Table

Process	Gun
GMAW – Hard or Cored Wires	Bernard Q300 or Q400
FCAW – Self-Shielding Wires	Dura-Flux With 12 in. Head Tube

## 4-4. Equipment Connection Diagram

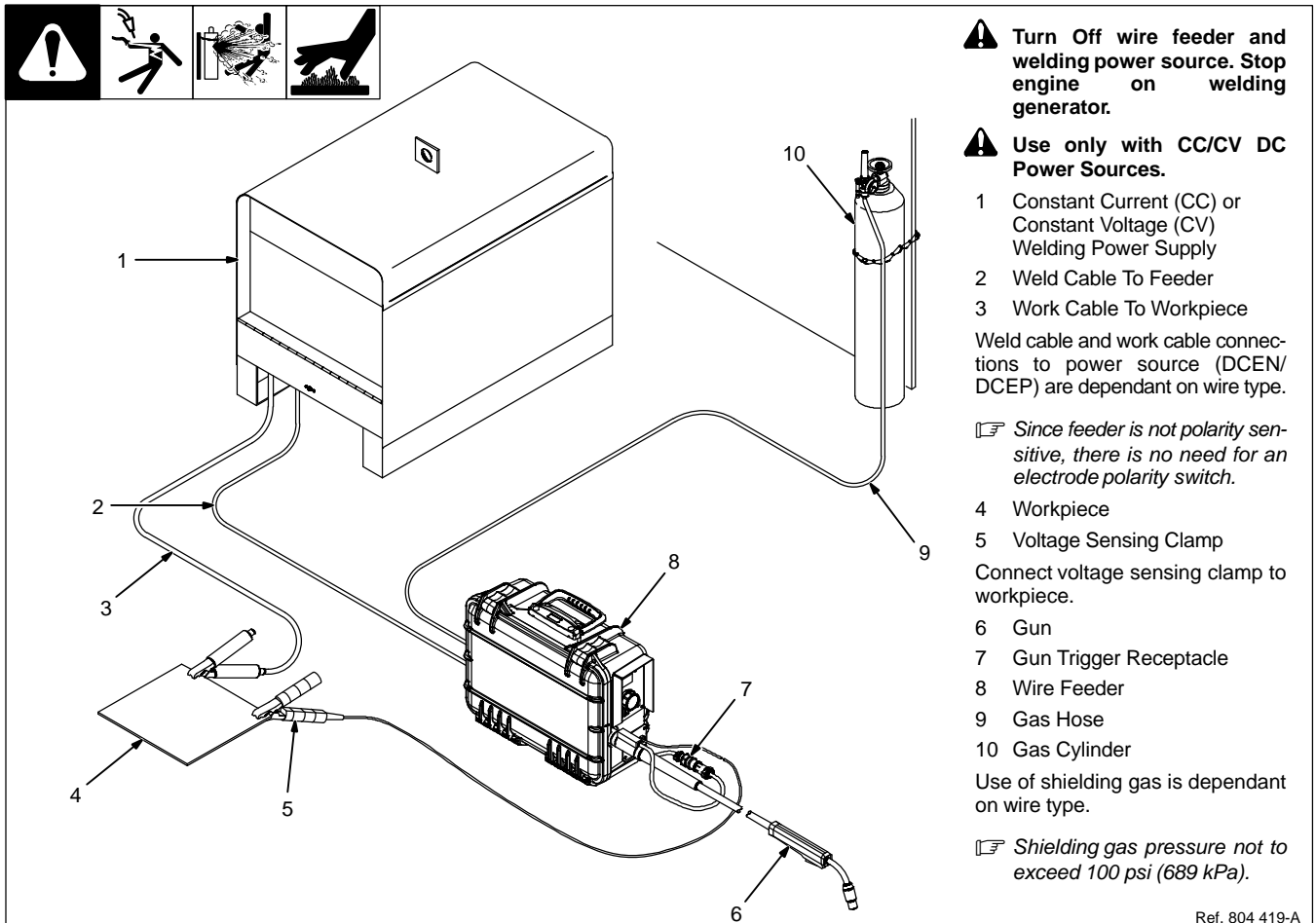



## 4-5. Installing And Aligning Wire Guide And Drive Rolls

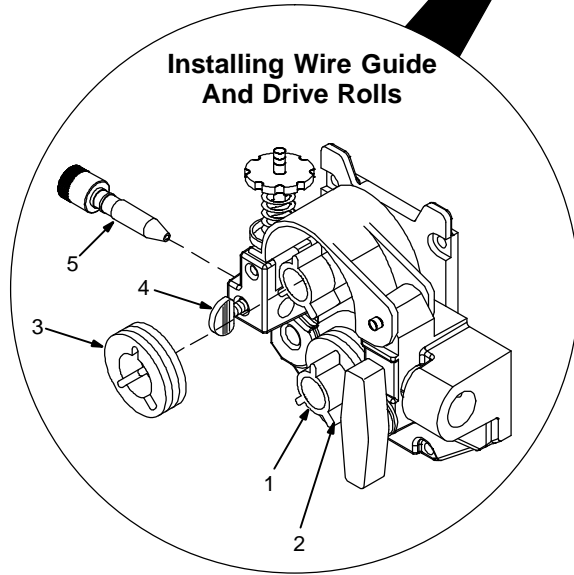
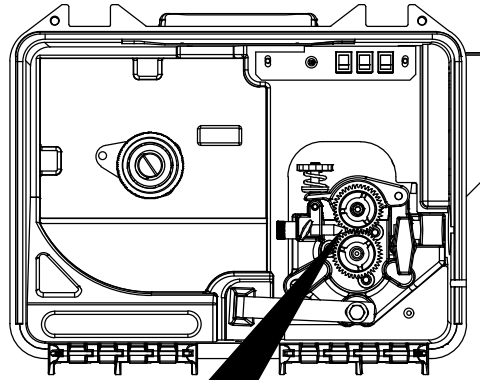
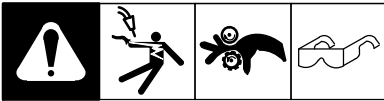

### Installing Wire Guide And Drive Rolls:

- 1 Drive Roll Securing Nut
- 2 Drive Roll Carrier

Turn nut one click until lobes of nut line up with lobes of drive roll carrier.

- 3 Drive Roll

Slide drive roll onto drive roll carrier. Turn nut one click.

Repeat procedure for top drive roll.

- 4 Inlet Wire Guide Screw
- 5 Inlet Wire Guide

Loosen securing screw. Install inlet guide so inlet guide screw is centered in groove in guide, or so tip is as close to drive rolls as possible without touching. Tighten screw.

### Aligning Wire Guide And Drive Rolls:

View is from top of drive rolls looking down with pressure assembly open.

- 6 Drive Roll Securing Nut
- 7 Drive Roll
- 8 Inlet Wire Guide
- 9 Welding Wire
- 10 Drive Gear

Turn screw in or out until drive roll groove lines up with wire guide.

Close pressure roll assembly.

Only bottom drive roll alignment is adjustable. Turn adjustment screw in or out until groove in drive roll lines up with wire guide as shown.

### Cleaning Drive Rolls:

Remove drive rolls, and clean grooves using a wire brush.

### Aligning Wire Guide And Drive Rolls

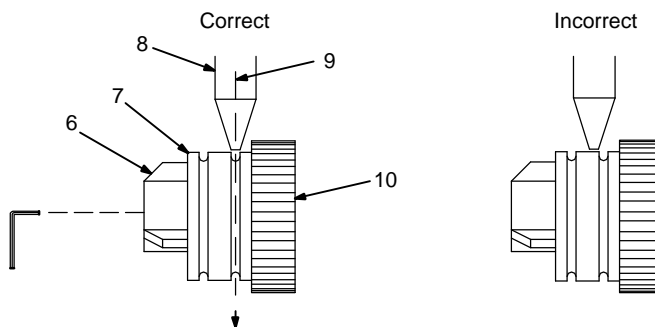

Tools Needed:

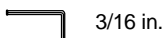

3/16 in.

Ref. 804 210-B / 804 416-A

## 4-6. Connecting Welding Gun And Voltage Sensing Clamp



**⚠ Turn Off wire feeder and welding power source. Stop engine on welding generator.**

- 1 Gun Securing Knob
- 2 Gun Block
- 3 Gun Power Pin
- 4 Power Pin Groove
- 5 Gun Locking Tab

Loosen knob, insert gun end into block. Position power pin as close as possible to drive rolls without touching. Align the gun power pin groove with the gun locking tab. Tighten knob.

- 6 Gun Trigger Plug
- 7 Gun Trigger Receptacle
- 8 Voltage Sensing Clamp

Connect gun trigger plug to gun trigger receptacle. Connect voltage sensing clamp to workpiece.

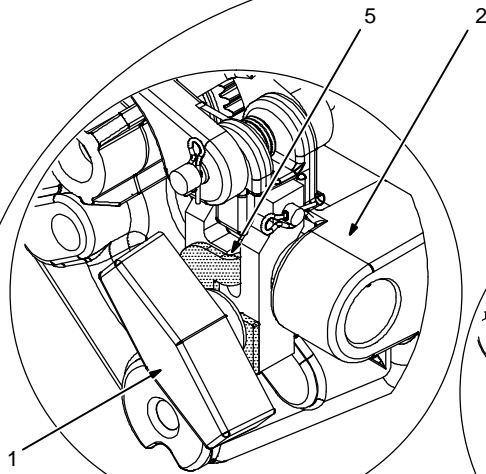

**Gun Locking Tab In Place**

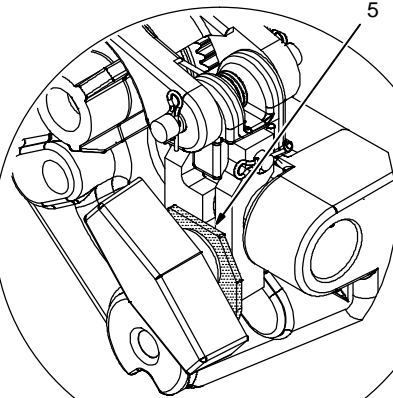

**Gun Locking Tab Out Of Place**

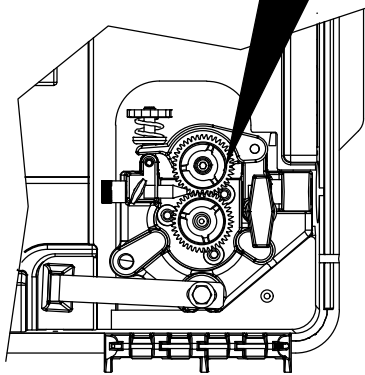

**Internal Side View**

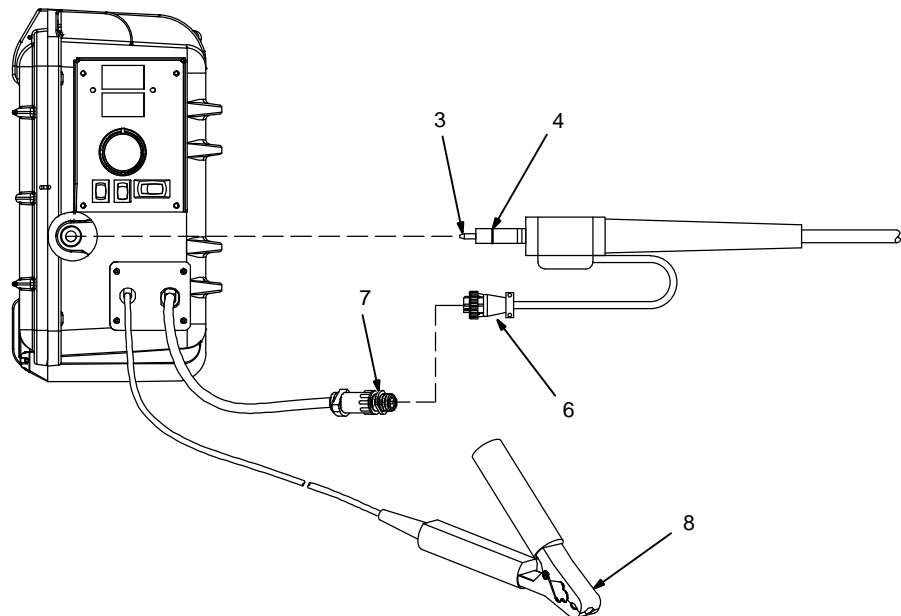

## 4-7. Connecting Shielding Gas

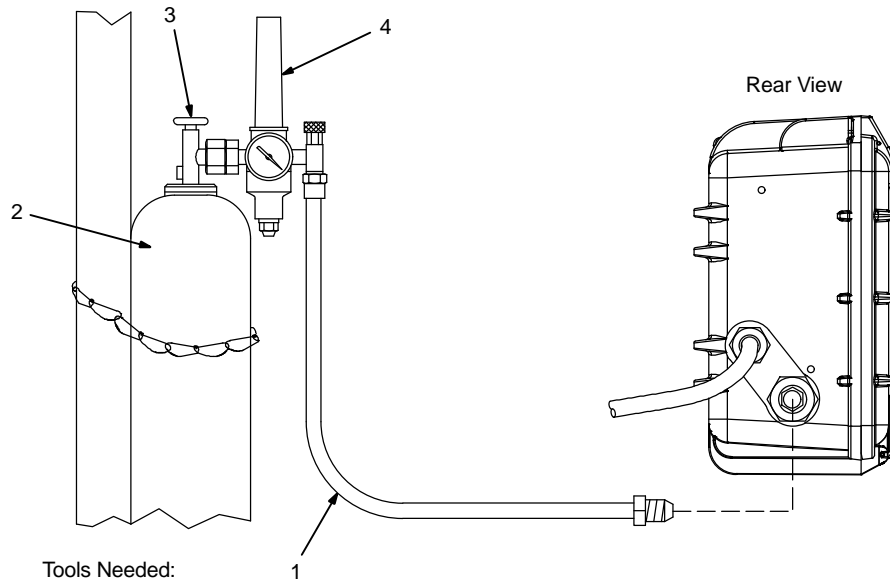

Tools Needed:

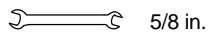

- 1 Gas Hose With 5/8-18 Right-hand Thread Fittings (Customer Supplied)
- 2 Shielding Gas Cylinder

 Shielding gas pressure not to exceed 100 psi (689 kPa).

- 3 Valve
- 4 Flowmeter

Close valve on cylinder when finished welding.

Ref. 804 420-A

## 4-8. Connecting Weld Cable

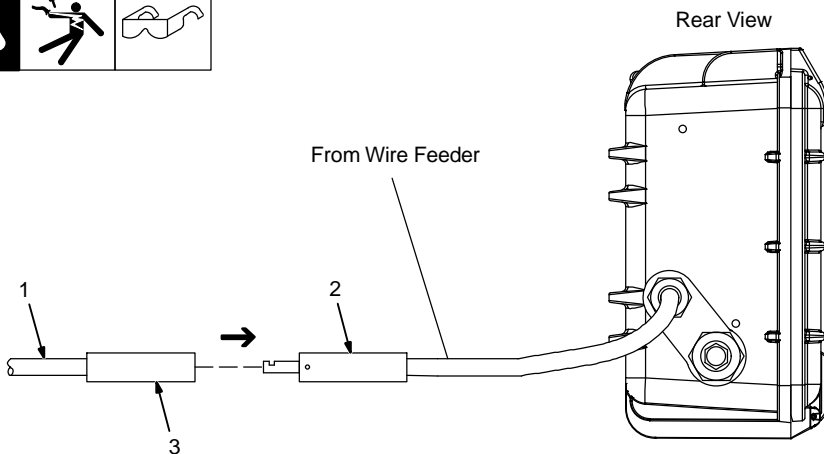

 **Turn Off wire feeder and welding power source. Stop engine on welding generator.**

- 1 User-Supplied Weld Cable

Follow wire manufacturer's recommendations for weld cable polarity.

- 2 User-Supplied Male Connector
- 3 User-Supplied Female Connector

Push female connector over male connector, and turn 1/4 turn clockwise.

804 421-A

## 4-9. Weld Output Terminals And Selecting Cable Sizes\*

**NOTICE** – The Total Cable Length in Weld Circuit (see table below) is the combined length of both weld cables. For example, if the power source is 30 m (100 ft) from the workpiece, the total cable length in the weld circuit is 60 m (2 cables x 30 m). Use the 60 m (200 ft) column to determine cable size.

 <p><b>Weld Output Terminals</b></p> <p>⚠ Turn off power before connecting to weld output terminals.</p> <p>⚠ Do not use worn, damaged, undersized, or poorly spliced cables.</p>	Weld Cable Size** and Total Cable (Copper) Length in Weld Circuit Not Exceeding***								
	100 ft (30 m) or Less		150 ft (45 m)	200 ft (60 m)	250 ft (70 m)	300 ft (90 m)	350 ft (105 m)	400 ft (120 m)	
	Welding Amperes	10 – 60% Duty Cycle AWG (mm <sup>2</sup> )	60 – 100% Duty Cycle AWG (mm <sup>2</sup> )	10 – 100% Duty Cycle AWG (mm <sup>2</sup> )					
100	4 (20)	4 (20)	4 (20)	3 (30)	2 (35)	1 (50)	1/0 (60)	1/0 (60)	
150	3 (30)	3 (30)	2 (35)	1 (50)	1/0 (60)	2/0 (70)	3/0 (95)	3/0 (95)	
200	3 (30)	2 (35)	1 (50)	1/0 (60)	2/0 (70)	3/0 (95)	4/0 (120)	4/0 (120)	
250	2 (35)	1 (50)	1/0 (60)	2/0 (70)	3/0 (95)	4/0 (120)	2x2/0 (2x70)	2x2/0 (2x70)	
300	1 (50)	1/0 (60)	2/0 (70)	3/0 (95)	4/0 (120)	2x2/0 (2x70)	2x3/0 (2x95)	2x3/0 (2x95)	
350	1/0 (60)	2/0 (70)	3/0 (95)	4/0 (120)	2x2/0 (2x70)	2x3/0 (2x95)	2x3/0 (2x95)	2x4/0 (2x120)	
400	1/0 (60)	2/0 (70)	3/0 (95)	4/0 (120)	2x2/0 (2x70)	2x3/0 (2x95)	2x4/0 (2x120)	2x4/0 (2x120)	
500	2/0 (70)	3/0 (95)	4/0 (120)	2x2/0 (2x70)	2x3/0 (2x95)	2x4/0 (2x120)	3x3/0 (3x95)	3x3/0 (3x95)	

\* This chart is a general guideline and may not suit all applications. If cable overheats, use next size larger cable.

\*\*Weld cable size (AWG) is based on either a 4 volts or less drop or a current density of at least 300 circular mils per ampere.  
( ) = mm<sup>2</sup> for metric use

\*\*\*For distances longer than those shown in this guide, call a factory applications rep. at 920-735-4505 (Miller) or 1-800-332-3281 (Hobart).

Ref. S-0007-J 2011-07

## 4-10. Installing And Threading Welding Wire



☞ Hold wire tightly to keep it from unraveling.

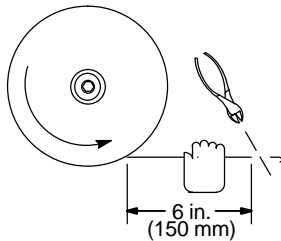
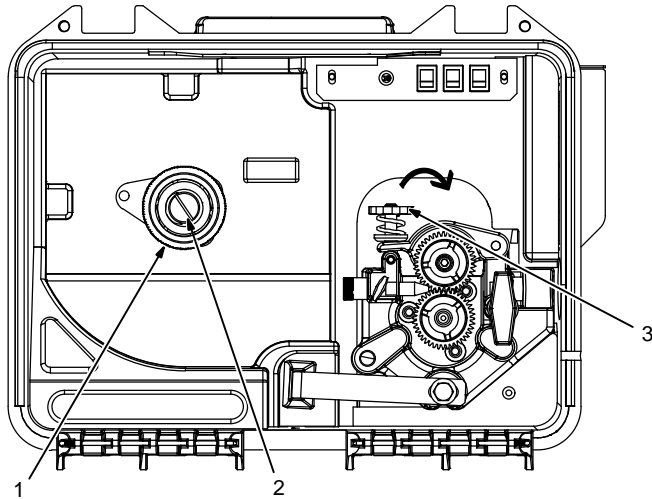

Pull and hold wire; cut off end.

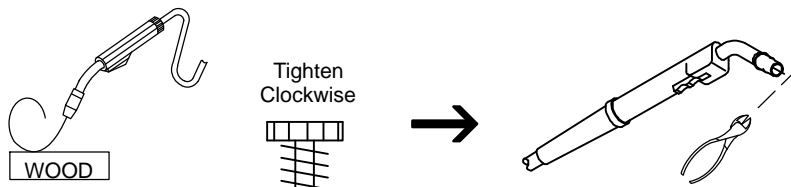

### Installing Wire And Adjusting Hub Tension:

- 1 Retaining Nut
  - 2 Hub Tension Adjustment Knob
- Remove retaining ring, and install spool so hub pin fits spool hole. Re-install retaining nut.

Adjust tension knob so only a slight force is needed to turn spool.

☞ Do not over tighten tension knob. It is not necessary to use any tools to tighten the knob.

### Threading Welding Wire:

- 3 Pressure Assembly Adjustment Knob

Lay gun cable out straight.

Open pressure assembly, hold wire tightly, and cut off end. Push wire through guides into gun.

Close and tighten pressure assembly. Press jog switch until wire comes out gun.

To set the proper drive roll tension, release the tension on the drive rolls. Position gun at about a 45 degree angle, with nozzle about two inches from a wooden surface. Increase the tension while feeding the wire against the wooden surface to one half turn past the point where the wire stops slipping. If the wire slips at maximum hand tight tension there may be other problems. Check the gun liner, spool tension, contact tips, drive roll wear, drive roll alignment and inlet guide as all these can cause feeding problems.

Cut off wire, and close door.

Ref. 804 855-A

## 4-11. Display Board (PC20) DIP Switch Settings

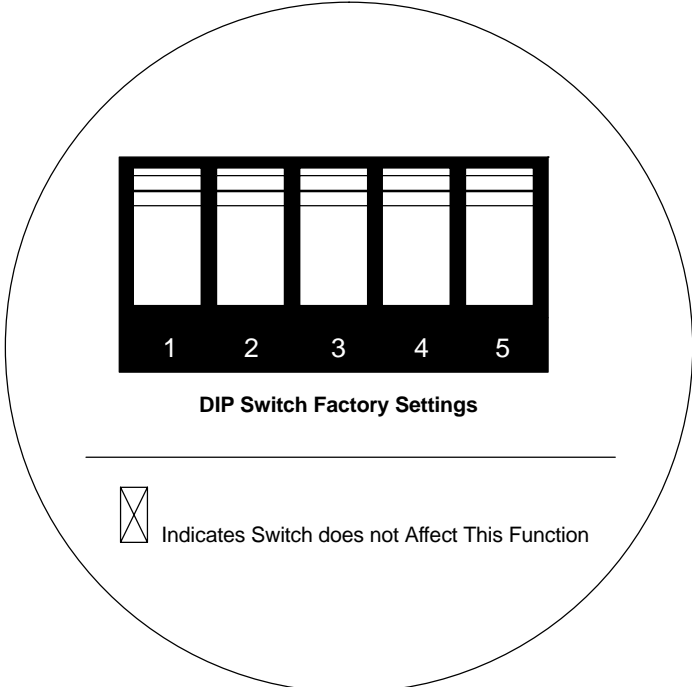

DIP switch is located behind front panel as shown.

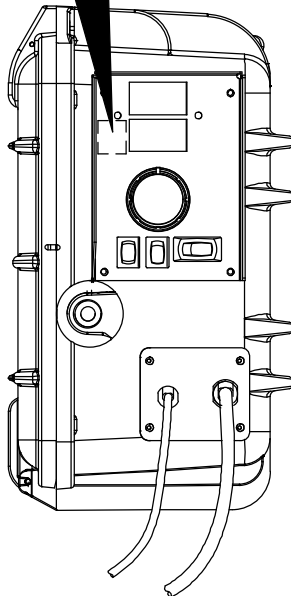

Ref. 804 876-A

### DIP Switch Settings:

#### Display Hold ON

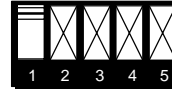

Displays will hold their last value for five seconds after the trigger is released. After the hold times out, the Voltage Display will show open circuit voltage. If the Wire Speed / Amps Display is set to display Amps, the amperage value will hold, after the hold times out, preset Wire Speed will be displayed.

#### Display Hold OFF

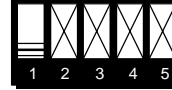

Displays will not hold values. Immediately, when the trigger is released, the Voltage Display will show open circuit voltage. The Wire Speed / Amps Display will display preset Wire Speed when the trigger is released.

#### Do Not Display Amperage

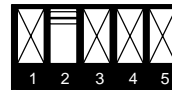

Wire Speed / Amps Display will display only Wire Speed.

#### Display Amperage

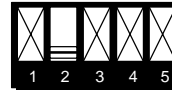

Wire Speed / Amps Display will display Amps while welding and Wire Speed while not welding. If the hold function is enabled, Amps will be displayed during hold also.

#### Wire Speed - Inches Per Minute

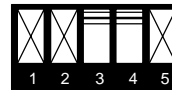

Displays Wire Speed in Inches per Minute.

#### Wire Speed - Meters Per Minute

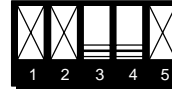

Displays Wire Speed in Meters per Minute.

#### Information OFF

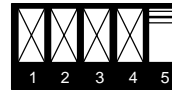

Information is not displayed.

#### Information ON

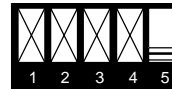

With switch in ON position, at feeder power up, feeder will display various sets of information. Each set of information will be displayed for three seconds.

#### Display Board (PC20) Software Part Number -

Top display will show the first three digits, bottom display will show last three digits of the Display board (PC20) software revision level.

#### Motor Board (PC1) Software Part Number -

Top display will show the first three digits, bottom display will show last three digits, of the Motor board (PC1) software revision level.

#### Accumulated Weld Time -

This is the time the feeder has actually been used for welding. This information will be displayed in two halves. First being years and days, second in hours and minutes. Top display will show years/hours, bottom display will show days/minutes.

# SECTION 5 – OPERATION

## 5-1. Controls With Meters

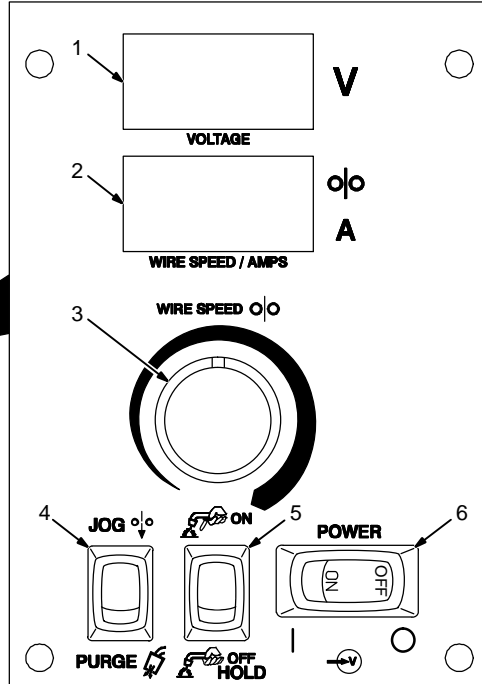
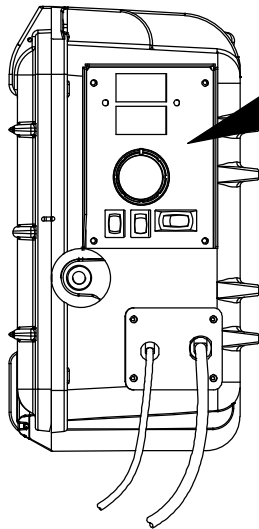
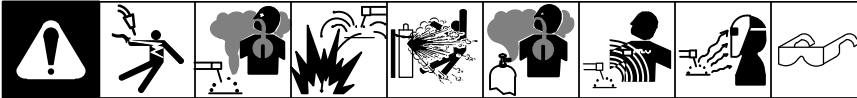

Front Panel With Meters

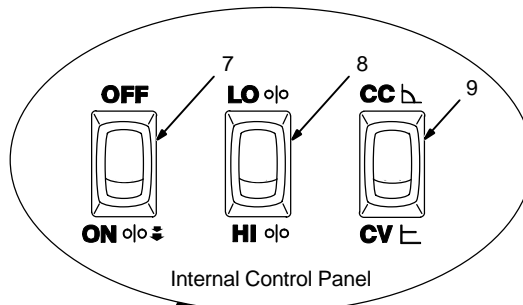

Internal Control Panel

Internal Side View

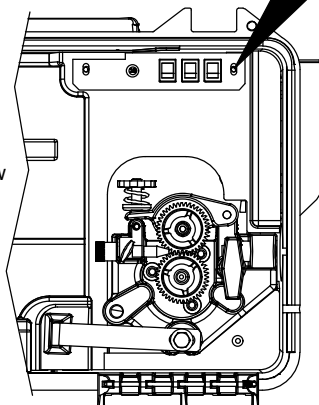

### 1 Voltmeter

Displays actual arc voltage while welding or open circuit voltage while idle at the feeder. The voltage displayed while welding is an average reading over a time span of 6 to 8 seconds. If the weld time is less than 8 seconds, the voltage displayed may not be accurate.

### 2 Wire Speed / Amperage Meter

Displays wire speed in Inches per Minute. To display wire speed in Meters per Minute, see Section 4-11.

Amperage displayed at the feeder is approximate. Refer to power source for actual amperage. To display Amperage, see Section 4-11.

### 3 Wire Speed Control

Use control to adjust wire speed within the speed range selected by the wire speed range switch, located on the inner control panel. Maximum wire speed may be limited by arc voltage.

### 4 Jog/Purge Switch

Pressing the Jog switch allows the operator to jog wire without energizing the contactor or gas valve.

Pressing the Purge switch allows the operator to purge gas lines before welding and to preset gas flow rate at the flowmeter.

### 5 Trigger Hold Switch (Optional)

Trigger hold allows operator to weld without holding gun trigger.

To use trigger hold function, place trigger hold switch in the ON position.

The operator must hold the trigger for a minimum of 2 seconds, but no longer than 6 seconds before releasing it. Welding will continue when trigger is released.

To stop welding, press and release the trigger.

### 6 Power Control Switch

### 7 Soft Start Switch

The Soft Start feature provides a smooth start during most weld conditions. When the trigger is pulled, the wire speed is approximately 50% of the weld wire speed, as set by the wire speed control knob. After an arc is established, the wire speed increases to the weld wire speed.

When using small diameters wire, or with inverter power sources, it may be necessary to turn switch off to obtain smooth starts.

### 8 HI/LO Speed Range Switch

Use switch to select speed range. High range is 175 to 780 Inches per minute. Low range is 25 to 200 Inches per minute.

### 9 CC/CV Switch

Use switch to match feeder with the output of the power source.

After adjusting the switches, close and latch the door before welding.

## 5-2. Gun Consumables Information

### IRONMATE FC-1260 Consumables

<b>1. Contact Tips</b> 198784 - .045" 198785 - 1/16" 198786 - .068-.072" 198788 - 5/64"
<b>2. Insulated Nozzles</b> 198801 - 1/8" stickout 198802 - 2" stickout 198803 - 2 3/4" stickout 198800 - Thread protector

<b>3. Goosenecks</b> (Includes Liners)	<b>Liners</b>
198796 - 6°/30° 199335 - 6°/30° Jacketed 198794 - 6°/50° 199332 - 6°/50° Jacketed	198791
198798 - 6°/90° 199334 - 6°/90° Jacketed 198799 - straight 8°/5°	198792
198797 - 12°/30° 199336 - 12°/30° Jacketed 198795 - 12°/50° 199333 - 12°/50° Jacketed	198793

<b>4. Gun Liners</b> 195731 - 1/16-3/32" dia. 199178 - .045" dia.
These parts are included with gooseneck. See Owner's Manual to order separately.

195732 - 10ft  
195729 - 15ft

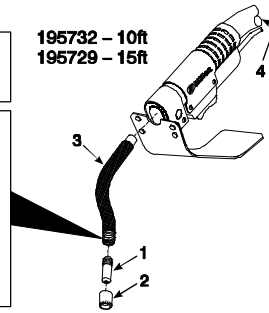

### ROUGHNECK Consumables

<b>1. Standard FasTip</b> 206175 - .023" 206176 - .030" 206177 - .035" 206179 - .045" 206180 - .052" 206181 - 1/16" 206182 - .068" 206183 - 5/64"
---

<b>1. Heavy Duty FasTip</b> 206186 - .035" 206187 - .040" 206188 - .045" 206189 - .052" 206190 - 1/16" 206191 - .068" 206192 - 5/64"
---

<b>2. Standard Nozzle</b> 198855 - 300/400 A 199618 - 500/600 A
<b>3. Diffuser</b> 206195 - 1/8" recess 206196 - flush 210664 - 1/4" recess

<b>4. Goosenecks</b> 199625 - 4.5°/48 199626 - 6°/48 199627 - 8°/48 213450 - 6°/straight
<b>5. Insulator</b> 198856

<b>6. Gun Liners</b> 202889 - .023-.030" wire 202890 - .035-.045" wire 202891 - .052-1/16" wire 202892 - 1/16-.078" wire 202893 - 5/64-3/32" wire
--

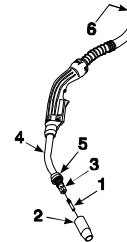

Additional parts available.

### Q-Gun™ Replacement Parts & Centerfire™ Consumables

<b>1. T Series Tip</b> T-023 - .023" T-030 - .030" T-035 - .035" T-039 - .039" T-045 - .045" T-052 - .052" T-062 - 1/16" T-072 - .072" T-078 - 5/64"
---

<b>1. TT Series Tip Tapered Tip</b> TT-023 - .023" TT-030 - .030" TT-035 - .035" TT-039 - .039" TT-045 - .045" TT-052 - .052" TT-062 - 1/16" TT-062 - 1/16"
---

<b>2. Nozzles</b> 5/8" ID Copper N-5800C - Flush N-5818C - 1/8" Recess N-5814C - 1/4" Recess
<b>2. Nozzles (Small)</b> 5/8" ID Copper NS-5800C - Flush NS-5818C - 1/8" Recess NS-5814C - 1/4" Recess

<b>3. Diffuser</b> D-1 DS-1
<b>4. Cap</b> 10012 4323R
<b>5. Neck</b> QT2-45 - 3.4° 45° QT3-45 - 4.8° 45° QT5-45 - 6.8° 45° QT-180 - 5 - 5.2" Str

<b>6. Gun Liners For Standard Wires</b> 43015 - .023-.030" wire 44115 - .035-.045" wire 44215 - .045-1/16" wire 1920170 - 5/64" wire
<b>6. Gun Liners - Nylon</b> 43015X - .035" Alum. wire 43115X - 3/64" Alum. wire 44215X - 1/16" Alum. wire

<b>7. Jump Liners For Standard Wires</b> QJL-2330 - .023-.030" QJL-3545 - .035-.045" QJL-116 - 1/16" QJLH-116 - 1/16" HD
<b>7. Jump Liners - Nylon</b> QJLN-364 - .035-3/64" QJLN-116 - 1/16"

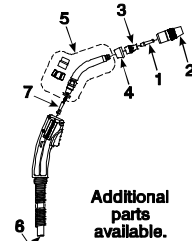

Additional parts available.

### Dura-Flux™ Replacement Parts & Centerfire™ Consumables

<b>1. Tip Insulator</b> 7010024
<b>2. Slip-On Tip Holder</b> 7010026

<b>3. T Series Tip</b> T-062 - 1/16" T-072 - .072" T-078 - 5/64"
---

<b>4. Neck w/Liner</b> 1880232 - 6° 30° 1880222 - 6° 60° 1880230 - 8° 90° 1880223 - 12° 30° 1880231 - 12° 60°
--

<b>4. Armored Neck w/Liner</b> 1880233 - 6° 60° 1880234 - 12° 30° 1880235 - 8° 90° 1880236 - 6° 30° 1880237 - 12° 60°
--

<b>5. Neck Liner</b> 7010031 - 6" 7010032 - 12"
<b>6. Power Pin Liner</b> 7010035

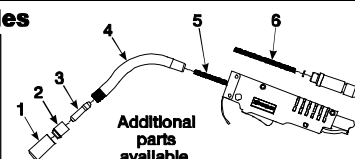

Additional parts available.

235 264-A

## Notes



# SECTION 6 – MAINTENANCE & TROUBLESHOOTING

## 6-1. Routine Maintenance

		<b>Disconnect power before maintaining.</b>		<i>Maintain more often during severe conditions.</i>
<b>3 Months</b>				
				Replace Damaged Or Unreadable Labels
				Replace Damaged Gas Hose
				Repair Or Replace Cracked Cables And Cords
<b>6 Months</b>				
				Clean Drive Rolls
				Blow Out Or Vacuum Inside

## 6-2. Overload Protection And Thermostat Protection

		<b>Turn Off wire feeder and welding power source. Stop engine on welding generator.</b>	
<p>Internal Side View</p>		1 Supplementary Protector CB1 CB1 protects wire feeder from overload. Correct problem and reset CB1. Close and latch door.	
		<b>Thermostat Protection</b> Unit has internal thermostat protection and will not feed wire if overheating occurs (see Section 6-3).	

Ref. 804 855-A

### 6-3. Troubleshooting

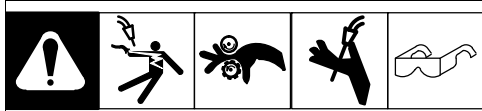

Trouble	Remedy
Wire does not feed; open-circuit voltage available.	Check power switch S1 and connections, and replace if necessary.
	Check supplementary protector CB1. Reset CB1.
	Unit overheated. Allow unit to cool.
	Check sensing lead connection.
	Check gun trigger plug connection.
	Check gun trigger. See gun Owner's Manual.
	Have Factory Authorized Service Agent check Control board PC1.
Wire feeds erratically.	Readjust hub tension.
	Readjust drive roll pressure.
	Clean or replace dirty or worn drive roll (see Section 4-5).
	Remove weld spatter around nozzle opening.
	Replace contact tip or liner. See gun Owner's Manual.
	Change to correct size and type drive roll (see Section 4-5)
	Incorrect size or worn wire guides (see Section 4-5)
	Check wire drive motor brushes.
	Have Factory Authorized Service Agent check control board PC1.
	Hub tension set too high (see Section 4-10).
Motor runs slowly.	Check and replace contact tip or liner if necessary.
	Have Factory Authorized Service Agent check Control board PC1.
	If soft start is not on, motor will switch to slower speed if current is not sensed by HD1.
	When soft start is on, motor will run slow until weld current is sensed by HD1.
	Hub tension set too high (see Section 4-10).
Unit does not switch out of Soft Start.	Check transducer HD1 and connections, and replace if necessary.
Wire feeds when Jog switch is pressed but not when gun trigger is pressed.	Check gun trigger connection at wire feeder. Check gun trigger leads and trigger switch. See gun Owner's Manual.
	Have Factory Authorized Service Agent check Control board PC1.
Wire stubbing on low end using a constant current power source or feeder re-sets.	Make sure CC/CV switch is in CC position (see Section 5-1).
	Increase power source inductance setting if available.
	Increase output setting of power source or decrease wire feed speed.
Gas does not flow or does not stop flowing; wire feeds.	Check gas valve.
	Check coil voltage and connections of gas valve GS1. Check continuity of coil. Replace GS1 if necessary.
	Have Factory Authorized Service Agent check Control board PC1.
	Clear blockage in gas hose or replace hose.
	Clear blockage in welding gun.
Wire remains energized after trigger is released.	Check contactor W1 to see if contacts are frozen closed.

Trouble	Remedy
Gun trigger is pressed, gas does not flow, wire is not energized, wire feeds.	If a welding arc is not established in 3 seconds, after the gun trigger is activated, the unit will feed wire without energizing the contactor or gas valve. If the gun trigger is still activated after two minutes, the wire will stop feeding. This is to prevent complete despooling of the wire, as in the case of a damaged gun.
Display on display board does not light.	Have Factory Authorized Service Agent check Control board PC1.
	Replace display board.
Segments on the display board are missing.	Replace display board.
Arc voltage on display board is not accurate.	Arc voltage on the display board will show weld voltage at the feeder. Due to voltage drops in the weld cables, arc voltage at the feeder will not match arc voltage at the welding power source. Due to averaging of arc voltage, if weld time is less than 8 seconds the displayed arc voltage at the feeder may not be accurate.
	Check Motor Control PC1 and connections, replace if necessary.
Weld amperage on display board is not accurate.	Weld amperage displayed on the feeder will not match exactly with the weld amperage displayed on the welding power source.
	Check DIP switch settings on Display board PC20 (see Section 4-11).
	Check transducer HD1 and connections, and replace contactor assembly if necessary.
	Check Motor Control PC1 and connections, replace if necessary.
Software and weld time information on display board is not accurate.	Check DIP switch settings on Display board PC20 (see Section 4-11).
	Check Motor Control PC1 and connections, replace if necessary.

## 6-4. Diagnostics

Error Indicators		
Shown On Display	RED LED on Motor Board PC1	Error
HLP 11	1 Blink	Communication Error
HLP 12	2 Blinks	Trigger Error
HLP 14	4 Blinks (Constant Blinking)	Motor Overload Error
HLP 15	3 Blinks	Bus Bar Overheat Error

### Error Indications

Error conditions are indicated by a "HLP" message on the (optional) display, or by the blinking of the Red LED on Motor Board PC1. To view the Red LED, turn Off power source, remove shroud, and turn power source On. The Red LED blinks in a 2.5 second cycle. The number of blinks in this period indicates the type of error. If an error condition does not exist on the motor board, the Red LED is on steady.

### Communication Error

The communication error occurs 2.5 seconds after a loss of communication between the motor board and the meter board. The user may continue to weld with this error. The error may be cleared by turning power Off, waiting a minimum of two seconds, and turning power On.

### Trigger Error

The trigger error occurs if the user has the trigger held for more than two minutes without striking an arc. The error may be cleared by releasing the trigger.

### Motor Overload Error

The motor overload error can indicate that the motor has been drawing too much current for too long. To remedy this, reduce the wire feed speed or the wire feeder torque load/duty cycle. The error may be cleared by turning power Off, waiting a minimum of two seconds, and turning power On.

### Bus Bar Overheat Error

The bus bar overheat error can be caused by the arc drawing too much current for too long. To remedy this, reduce the weld amperage or duty cycle.

# SECTION 7 - ELECTRICAL DIAGRAM

**⚠ WARNING**

- Do not touch live electrical parts.
- Disconnect input power or stop engine before servicing.
- Do not operate with covers removed.
- Have only qualified persons install, use, or service this unit.

**ELECTRIC SHOCK HAZARD**

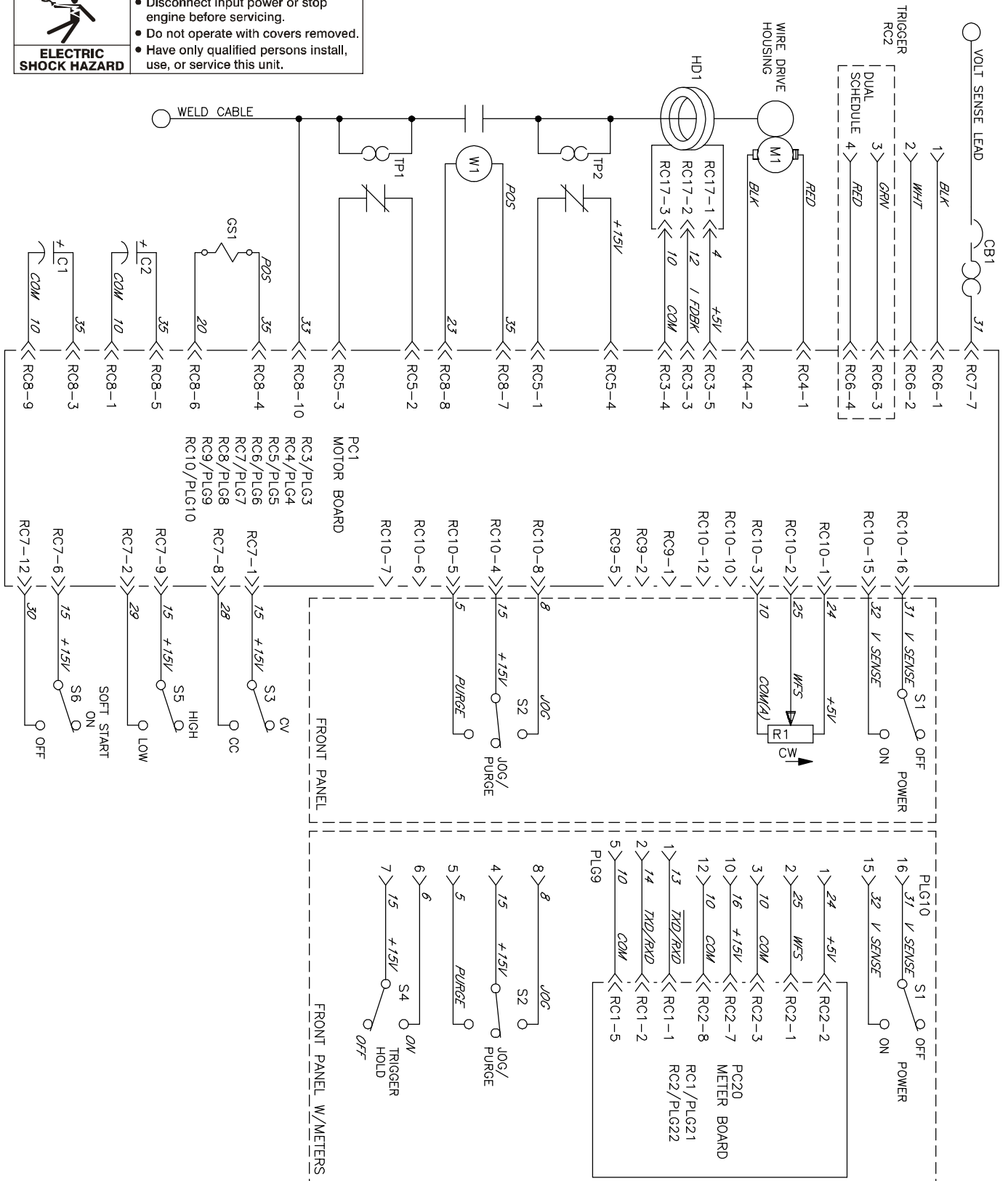



Figure 7-1. Circuit Diagram For Wire Feeder

# Notes

## DECIMAL EQUIVALENTS

	$\frac{1}{64}$	.015625
	$\frac{1}{32}$	.03125
	$\frac{3}{64}$	.046875
$\frac{1}{16}$	$\frac{5}{64}$	.0625
	$\frac{7}{64}$	.078125
	$\frac{3}{32}$	.09375
$\frac{1}{8}$	$\frac{9}{64}$	.109375
	$\frac{11}{64}$	.125
	$\frac{5}{32}$	.140625
	$\frac{13}{64}$	.15625
$\frac{3}{16}$	$\frac{15}{64}$	.171875
	$\frac{17}{64}$	.1875
	$\frac{7}{32}$	.203125
	$\frac{19}{64}$	.21875
$\frac{1}{4}$	$\frac{21}{64}$	.234375
	$\frac{23}{64}$	.25
	$\frac{9}{32}$	.265625
	$\frac{25}{64}$	.28125
$\frac{5}{16}$	$\frac{27}{64}$	.296875
	$\frac{29}{64}$	.3125
	$\frac{11}{32}$	.328125
	$\frac{31}{64}$	.34375
$\frac{3}{8}$	$\frac{33}{64}$	.359375
	$\frac{35}{64}$	.375
	$\frac{13}{32}$	.390625
	$\frac{37}{64}$	.40625
$\frac{7}{16}$	$\frac{39}{64}$	.421875
	$\frac{41}{64}$	.4375
	$\frac{15}{32}$	.453125
	$\frac{43}{64}$	.46875
$\frac{1}{2}$	$\frac{45}{64}$	.484375
	$\frac{47}{64}$	.5
	$\frac{17}{32}$	.515625
	$\frac{49}{64}$	.53125
$\frac{9}{16}$	$\frac{51}{64}$	.546875
	$\frac{53}{64}$	.5625
	$\frac{19}{32}$	.578125
	$\frac{55}{64}$	.59375
$\frac{5}{8}$	$\frac{57}{64}$	.609375
	$\frac{59}{64}$	.625
	$\frac{21}{32}$	.640625
	$\frac{61}{64}$	.65625
$\frac{11}{16}$	$\frac{63}{64}$	.671875
	$\frac{65}{64}$	.6875
	$\frac{23}{32}$	.703125
	$\frac{67}{64}$	.71875
$\frac{3}{4}$	$\frac{69}{64}$	.734375
	$\frac{71}{64}$	.75
	$\frac{25}{32}$	.765625
	$\frac{73}{64}$	.78125
$\frac{13}{16}$	$\frac{75}{64}$	.796875
	$\frac{77}{64}$	.8125
	$\frac{27}{32}$	.828125
	$\frac{79}{64}$	.84375
$\frac{7}{8}$	$\frac{81}{64}$	.859375
	$\frac{83}{64}$	.875
	$\frac{29}{32}$	.890625
	$\frac{85}{64}$	.90625
$\frac{15}{16}$	$\frac{87}{64}$	.921875
	$\frac{89}{64}$	.9375
	$\frac{31}{32}$	.953125
	$\frac{91}{64}$	.96875
$1$	$\frac{93}{64}$	.984375
	$\frac{95}{64}$	1.

# SECTION 8 – PARTS LIST

 Hardware is common and not available unless listed.

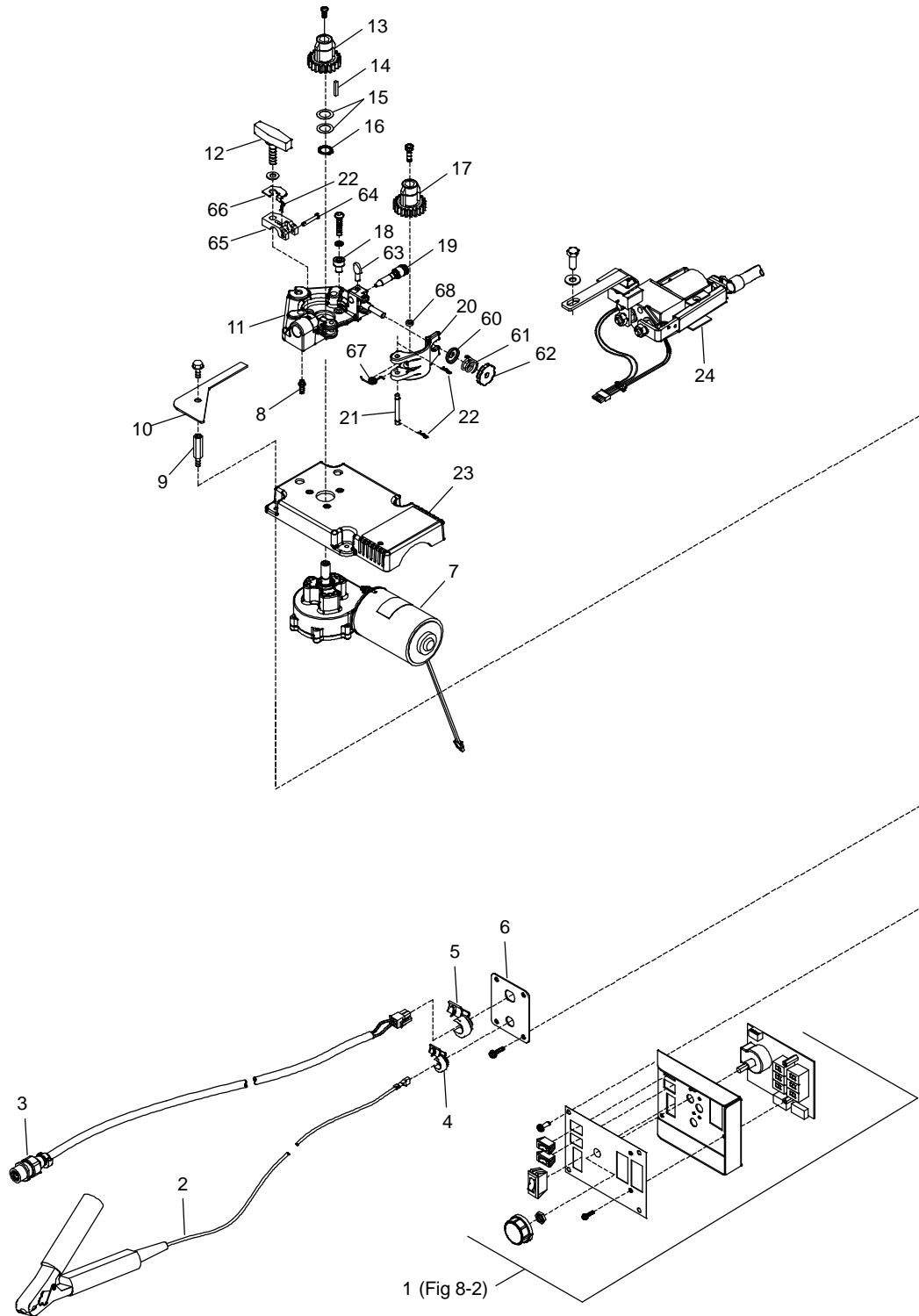
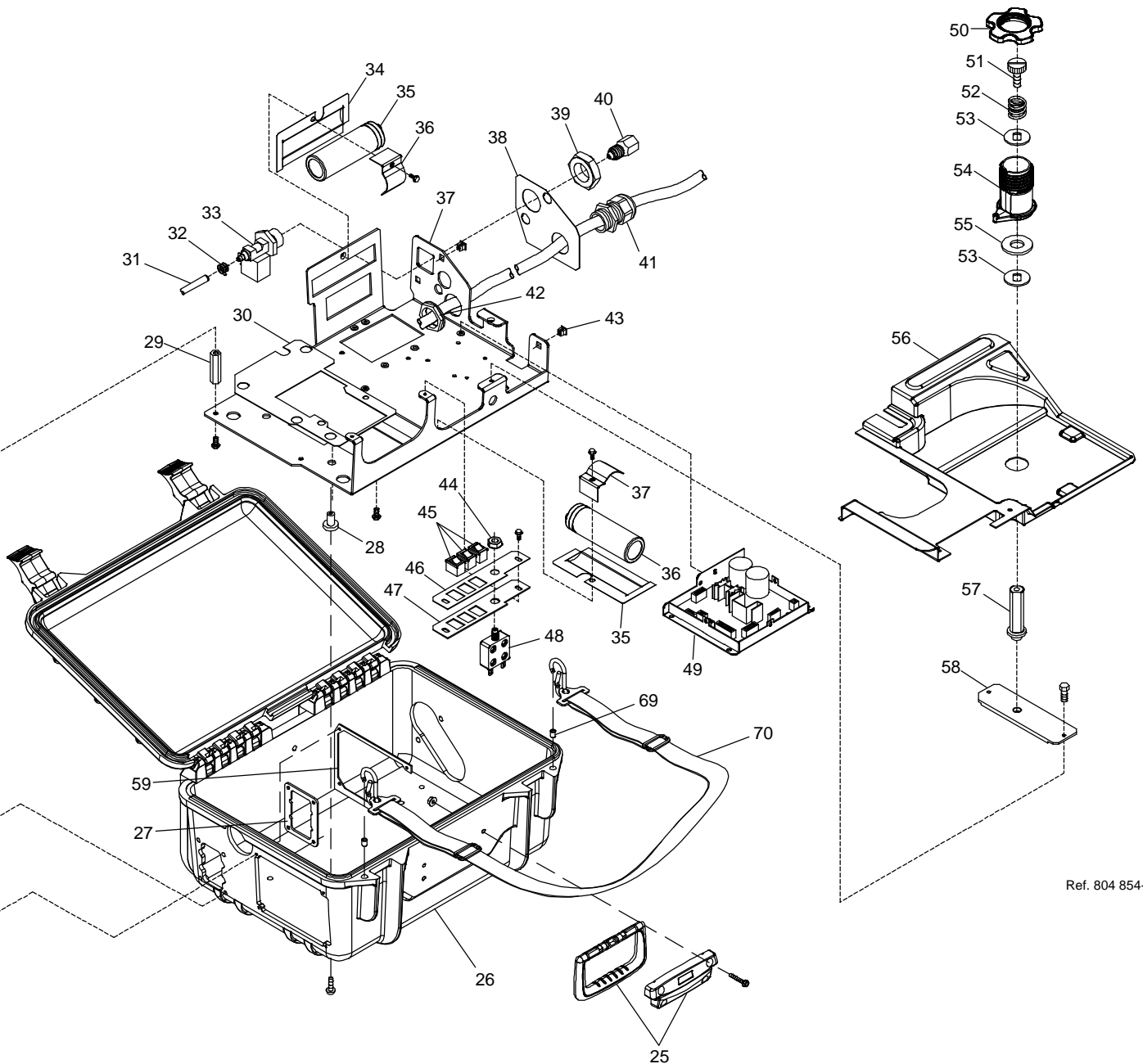

Figure 8-1. Exploded View Of SuitCase X-TREME 8 OS



Ref. 804 854-G

Item No.	Diagram marking	Part No.	Description	Quantity
----------	-----------------	----------	-------------	----------

**Figure 8-1. Complete Assembly**

1	.....	Fig 8-2	.. Panel Assembly, Front (With Meters)	1
2	.....	214 011	.. Cable, Sensing (Includes)	1
	.....	247 710	.... Wire, Strd 12Ga Blk 600v 105C 65x30 Ep .187Od	16 ft
	.....	208 820	.... Clamp, Work	1
3	.....	221 998	.. Cable, Trigger 25 In (Includes)	1
	.....	PLG6	.... Housing Plug+Skts, (Service Kit)	1
	.....	049 445	.... Cable, Port No 18 2/C Type Sjo Nprn Jkt	3 ft
	.....	RC2	.... Rcpt W/Skts, Free Hanging	1
	.....	048 834	.... Conn, Circ Cpc Clamp Str Rlf Size 11 .329 Od	1
4	.....	230 228	.. Bushing, Strain Relief .120/.150 Id X .500 Mtg Hole	1
5	.....	230 227	.. Bushing, Strain Relief .300 Id X .550/.625 Mtg Hole	1
6	.....	214 007	.. Panel, Front Lower	1
7	.....	M1	.. Motor, Right Angle 23.6VDC 28:3:1 Gear Ratio	1

Item No.	Diagram marking	Part No.	Description	Quantity
----------	-----------------	----------	-------------	----------

**Figure 8-1. Complete Assembly (Continued)**

8		144 172	Ftg, Hose Brs Barbed M 3/16 Tbg X .250-20	1
9		215 719	Stand-Off, No 10-32 X 1.000 Lg .375 Hex Stl M&F	1
10		226 281	Shroud, Corner	1
11		239 650	Housing, Adapter Gun/Feeder W/Fastener	1
12		124 778	Knob, T 2.000 Bar W/.312-18 Stud 1.000 Lg Plstc	1
13		172 076	Carrier, Drive Roll W/Components Keyed 24 Pitch	1
14		092 685	Key	1
15		079 625	Washer, Wave	2
16		605 308	Ring, Rtnng	1
17		172 075	Carrier, Drive Roll W/Components 24 Pitch	1
18		173 620	Bushing, Mtg Motor	3
19		229 919	Guide, Wire Inlet Anti-Wear One PC (Up To 1/8 in.)	1
20		166 071	Lever, Mtg Pressure Gear	1
21		079 634	Pin, Hinge	1
22		151 828	Pin, Cotter Hair .042 X .750	3
23		173 616	Cover, Right Angle Motor	1
24	W1	232 454	Contactor W/Bus Bars, (Includes)	1
	PLG5	201 665	Housing Plug+Skts, (Service Kit)	1
	TP1, TP2	230 465	Thermostat, NC Open 120C Close 90C Snap Action	2
		183 387	Washer, Cone .380idx .860odx.109t Stl Pld 4000Lbs	4
		223 862	Nut, M10-1.5 17Hex 8H Brs Din 934	2
25		208 015	Handle, Rubberized Carrying	1
26		244 841	Case, Control Feeder Machined SC	1
27		214 010	Panel, Front Lower Backing Plate	1
28		081 895	Nut, 010-32 Rubber .75Dia .81l Insert In .38Hole	3
29		200 613	Stand-Off, No 10-32 X 1.835 Lg .500 Hex Stl Fem	2
30		244 551	Insulator, Motor	1
31		200 814	Hose Assy, Sae .187 Id X .410 Od X 17.000 W/Clamps	1
32		149 332	Clamp, Hose .405 - .485 Clp Dia Slftng Olive Dra	2
33	GS1	226 819	Valve, 12VDC 1Way .750-14 Thd 2mm Orf 100PSI	1
34		226 284	Insulator, Capacitors	2
35	C1, C2	200 606	Capacitor, Elctlt 1200 Uf 300 VDC Can 1.39 Dia	2
36		226 283	Bracket, Capacitor	2
37		226 287	Chassis, Control Box	1
38		226 286	Insulator, Rear Panel	1
39		220 805	Nut, 750-14 Nps 1.48Hex .41H Nyl	1
40		211 989	Fitting, W/Screen	1
41		139 041	Bushing, Strain Relief .450/.709 Id X1.115 Mtg Hole	1
42		254 843	Nut, Pg 21 1.50Hex .375H Aluminum	1
43		222 181	Grommet, Scr No 8/10 Panel Hole .281 Sq .031 High	3
44		147 195	Nut, 375-27 .54Hex .25h Nyl Flange .62D	1
45	S3, S5, S6	217 932	Switch, Rocker Spst .4VA 28VDC On-None-Off .187 Ter	3
46		244 600	Nameplate, Inner	1
47		226 732	Panel, Inner	1
48	CB1	083 432	Supplementary Pro, Man Reset 1P 10A 250VAC Frict	1
49	PC1	246 994	Circuit Card Assy, Motor Control W/Program	1
50		235 607	Nut, Hub	1
51		172 919	Knob, Brake Adjust	1
52		172 918	Spring	1
53		201 309	Washer, Anti-Turn	2
54		235 609	Hub, Spool 8 Inch	1
55		058 424	Washer, Fiber (Brake)	1
56		226 280	Shroud, Wire	1
57		226 753	Spindle, Spool Support W/Left Hand Thread (Torque to 37 ft lb (50.1 N·m))	1



Item No.	Diagram marking	Part No.	Description	Quantity
----------	-----------------	----------	-------------	----------

**Figure 8-1. Complete Assembly (Continued)**

58		244 552	Bracket, Spool Support	1
59		236 239	Panel, Front Upper Backing Plate	1
60		085 244	Washer, Cupped .328idx .812odx16gax.125 Lip	1
61		089 477	Spring, Cprsn .770 Od X .100 Wire X .715 Pld	1
62		240 975	Knob, Adjust Tension 1.250 Dia X .312-18 Thrd Stl	1
63		054 263	Screw, Thumb Stl .250-20 X .500 Pld Type P	1
64		234 073	Pin, Hinge	1
65		234 074	Clamp, Pin Power	1
66		237 188	Lock, Pin Power	1
67		222 159	Spring, Torsion	1
68		166 072	Spacer, Gear	1
69		246 727	Bushing, Sintered Bronze .250id X .313od X .250l	2
70		246 250	Strap, Shoulder	1
		244 598	Label, Warning / Side	1
		196 956	Label, Warning Electric Shock And Pinch Wordless	1
		222 306	Label, Warning General Precautionary Static Vert	2
	PLG3	130 203	Housing Plug+Skts, (Service Kit)	1
	PLG4	131 054	Housing Rcpt+Skts, (Service Kit)	1
	PLG5	201 665	Housing Plug+Skts, (Service Kit)	1
	PLG7	130 203	Housing Plug+Skts, (Service Kit)	1
	PLG8	115 091	Housing Plug+Skts, (Service Kit)	1
	PLG9, 21	131 055	Housing Rcpt+Skts, (Service Kit)	2
	PLG10	131 052	Housing Rcpt+Skts, (Service Kit)	1
	PLG14	227 529	Housing Plug+Skts, (Service Kit)	1
	PLG17	222 397	Housing Plug+Skts, (Service Kit)	1
	PLG22	115 092	Housing Plug+Skts, (Service Kit)	1

+When ordering a component originally displaying a precautionary label, the label should also be ordered.

**To maintain the factory original performance of your equipment, use only Manufacturer's Suggested Replacement Parts. Model and serial number required when ordering parts from your local distributor.**

☞ Hardware is common and not available unless listed.

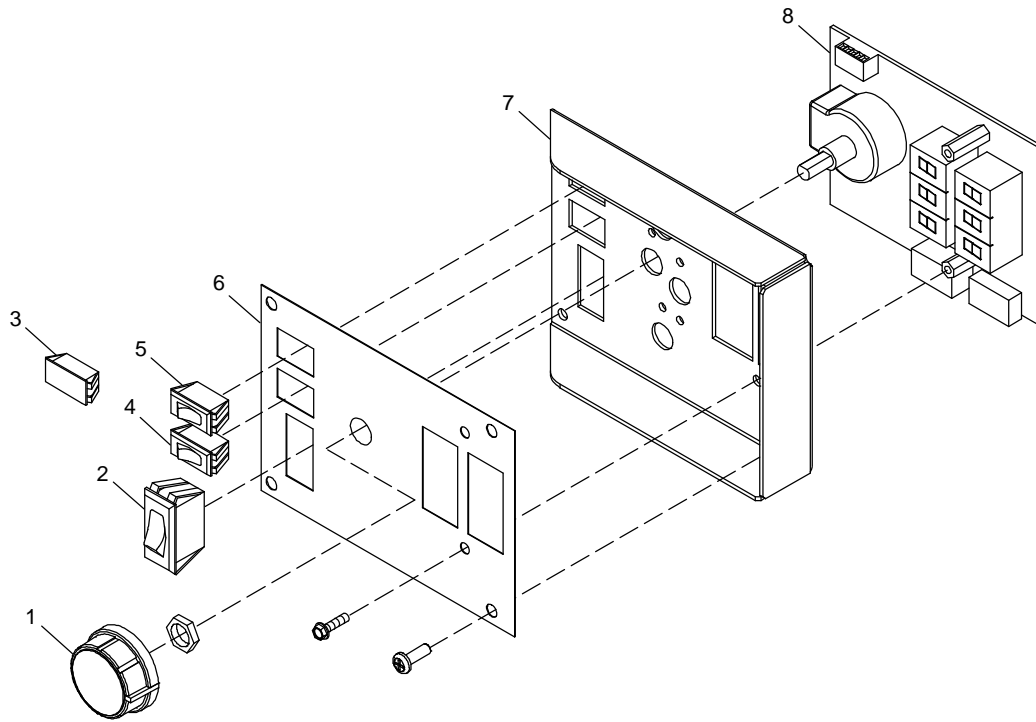

Ref. 804 854-A

**Figure 8-2. Front Panel Assembly with Meters**

Item No.	Dia. Mkgs	Part No.	Description	Quantity
----------	-----------	----------	-------------	----------

**Figure 8-2. Front Panel Assembly with Meters (Figure 8-1 Item 1)**

.. 1 .....		174 991	.. Knob, Pointer 1.250 Dia X .250 Id W/Spring Clip-.21 .....	1
.. 2 .....	S1	111 997	.. Switch, Rocker SPST 10A 250VAC On-Off Visi Red Rock .....	1
.. 3 .....		222 797	.. Blank, Snap-In Nyl Rect Mtg Hole Black (Standard) .. (For Units Not Equipped With Trigger Hold) .....	1
.. 4 .....	S4	217 932	.. Switch, Rocker SPST .4VA 28VDC On-None-Off .187 Ter (Optional) .....	1
.. 5 .....	S2	216 295	.. Switch, Rocker SPDT .4VA 28VDC (On)-Off-(On) .187T .....	1
.. 6 .....			.. Nameplate, W/Meters (Order By Model And Serial Number) .....	1
.. 7 .....		225 989	.. Panel, Front .....	1
.. 8 ...	PC20	226 373	.. Circuit Card Assy, Meter Suitcase W/Program .....	1

**To maintain the factory original performance of your equipment, use only Manufacturer's Suggested Replacement Parts. Model and serial number required when ordering parts from your local distributor.**

**Table 8-1. Drive Roll & Wire Guide Kits (2 Drive Roll)**

☞ Base selection of drive rolls upon the following recommended usages:

1. V-Grooved rolls for hard wire.
2. U-Grooved rolls for soft and soft shelled cored wires.
3. U-Cogged rolls for extremely soft shelled wires (usually hard surfacing types).
4. V-Knurled rolls for hard shelled cored wires.
5. Drive roll types may be mixed to suit particular requirements (example:  
V-Knurled roll in combination with U-Grooved).

Wire Diameter			Drive Roll (2 Required)		Inlet Wire
Fraction	Decimal	Metric	Part No.	Type	Guide
.023/.025 in	.023/.025 in	0.6 mm	087 130	V-Grooved	229 919
.030 in	.030 in	0.8 mm	053 695	V-Grooved	229 919
.035 in	.035 in	0.9 mm	053 700	V-Grooved	229 919
.040 in	.040 in	1.0 mm	053 696	V-Grooved	229 919
.045 in	.045 in	1.2 mm	053 697	V-Grooved	229 919
.052 in	.052 in	1.3 mm	053 698	V-Grooved	229 919
1/16 in	.062 in	1.6 mm	053 699	V-Grooved	229 919
.035 in	.035 in	0.9 mm	072 000	U-Grooved	229 919
.045 in	.045 in	1.2 mm	053 701	U-Grooved	229 919
.052 in	.052 in	1.3 mm	053 702	U-Grooved	229 919
1/16 in	.062 in	1.6 mm	053 706	U-Grooved	229 919
5/64 in.	.079 in.	2.0 mm	053 704	U-Grooved	229 919
.035 in	.035 in	0.9 mm	132 958	V-Knurled	229 919
.045 in	.045 in	1.2 mm	132 957	V-Knurled	229 919
.052 in	.052 in	1.3 mm	132 956	V-Knurled	229 919
1/16 in	.062 in	1.6 mm	132 955	V-Knurled	229 919
.068-.072 in.	.068-.072	1.8 mm	132 959	V-Knurled	229 919
5/64 in.	.079 in.	2.0 mm	132 960	V-Knurled	229 919
.045 in	.045 in	1.2 mm	083 489	U-Cogged	229 919
.052 in	.052 in	1.3 mm	083 490	U-Cogged	229 919
1/16 in	.062 in	1.6 mm	053 708	U-Cogged	229 919
5/64 in.	.079 in.	2.0 mm	053 710	U-Cogged	229 919

S-0859







# TRUE BLUE<sup>®</sup>

## WARRANTY

Effective January 1, 2011

(Equipment with a serial number preface of MB or newer)

This limited warranty supersedes all previous Miller warranties and is exclusive with no other guarantees or warranties expressed or implied.

### Warranty Questions?

Call  
1-800-4-A-MILLER  
for your local  
Miller distributor.

Your distributor also gives  
you ...

#### Service

You always get the fast,  
reliable response you  
need. Most replacement  
parts can be in your  
hands in 24 hours.

#### Support

Need fast answers to the  
tough welding questions?  
Contact your distributor.  
The expertise of the  
distributor and Miller is  
there to help you, every  
step of the way.

LIMITED WARRANTY – Subject to the terms and conditions below, Miller Electric Mfg. Co., Appleton, Wisconsin, warrants to its original retail purchaser that new Miller equipment sold after the effective date of this limited warranty is free of defects in material and workmanship at the time it is shipped by Miller. THIS WARRANTY IS EXPRESSLY IN LIEU OF ALL OTHER WARRANTIES, EXPRESS OR IMPLIED, INCLUDING THE WARRANTIES OF MERCHANTABILITY AND FITNESS.

Within the warranty periods listed below, Miller will repair or replace any warranted parts or components that fail due to such defects in material or workmanship. Miller must be notified in writing within thirty (30) days of such defect or failure, at which time Miller will provide instructions on the warranty claim procedures to be followed.

Miller shall honor warranty claims on warranted equipment listed below in the event of such a failure within the warranty time periods. All warranty time periods start on the delivery date of the equipment to the original end-user purchaser, and not to exceed one year after the equipment is shipped to a North American distributor or eighteen months after the equipment is shipped to an International distributor.

1. 5 Years Parts — 3 Years Labor
  - \* Original main power rectifiers only to include SCRs, diodes, and discrete rectifier modules
2. 3 Years — Parts and Labor
  - \* Engine Driven Welding Generators  
**(NOTE: Engines are warranted separately by the engine manufacturer.)**
  - \* Inverter Power Sources (Unless Otherwise Stated)
  - \* Plasma Arc Cutting Power Sources
  - \* Process Controllers
  - \* Semi-Automatic and Automatic Wire Feeders
  - \* Smith 30 Series Flowgauge and Flowmeter Regulators (No Labor)
  - \* Transformer/Rectifier Power Sources
  - \* Water Coolant Systems (Integrated)
3. 2 Years — Parts
  - \* Auto-Darkening Helmet Lenses (No Labor)
4. 1 Year — Parts and Labor Unless Specified
  - \* Automatic Motion Devices
  - \* CoolBelt and CoolBand Blower Unit (No Labor)
  - \* External Monitoring Equipment and Sensors
  - \* Field Options  
**(NOTE: Field options are covered for the remaining warranty period of the product they are installed in, or for a minimum of one year — whichever is greater.)**
  - \* Flowgauge and Flowmeter Regulators (No Labor)
  - \* RFCS Foot Controls (Except RFCS-RJ45)
  - \* Fume Extractors
  - \* HF Units
  - \* ICE Plasma Cutting Torches (No Labor)
  - \* Induction Heating Power Sources, Coolers, and Electronic Controls/Recorders
  - \* Load Banks
  - \* Motor Driven Guns (w/exception of Spoolmate Spoolguns)
  - \* PAPR Blower Unit (No Labor)
  - \* Positioners and Controllers
  - \* Racks
  - \* Running Gear/Trailers
  - \* Spot Welders
  - \* Subarc Wire Drive Assemblies
  - \* Water Coolant Systems (Non-Integrated)
  - \* Weldcraft-Branded TIG Torches (No Labor)
  - \* Wireless Remote Foot/Hand Controls and Receivers
  - \* Work Stations/Weld Tables (No Labor)

5. 6 Months — Parts
  - \* Batteries
  - \* Bernard Guns (No Labor)
  - \* Tregaskiss Guns (No Labor)

6. 90 Days — Parts
  - \* Accessory (Kits)
  - \* Canvas Covers
  - \* Induction Heating Coils and Blankets, Cables, and Non-Electronic Controls
  - \* M-Guns
  - \* MIG Guns and Subarc (SAW) Guns
  - \* Remote Controls and RFCS-RJ45
  - \* Replacement Parts (No labor)
  - \* Roughneck Guns
  - \* Spoolmate Spoolguns

Miller's True Blue<sup>®</sup> Limited Warranty shall not apply to:

1. **Consumable components; such as contact tips, cutting nozzles, contactors, brushes, relays, work station table tops and welding curtains, or parts that fail due to normal wear. (Exception: brushes and relays are covered on all engine-driven products.)**
2. Items furnished by Miller, but manufactured by others, such as engines or trade accessories. These items are covered by the manufacturer's warranty, if any.
3. Equipment that has been modified by any party other than Miller, or equipment that has been improperly installed, improperly operated or misused based upon industry standards, or equipment which has not had reasonable and necessary maintenance, or equipment which has been used for operation outside of the specifications for the equipment.

MILLER PRODUCTS ARE INTENDED FOR PURCHASE AND USE BY COMMERCIAL/INDUSTRIAL USERS AND PERSONS TRAINED AND EXPERIENCED IN THE USE AND MAINTENANCE OF WELDING EQUIPMENT.

In the event of a warranty claim covered by this warranty, the exclusive remedies shall be, at Miller's option: (1) repair; or (2) replacement; or, where authorized in writing by Miller in appropriate cases, (3) the reasonable cost of repair or replacement at an authorized Miller service station; or (4) payment of or credit for the purchase price (less reasonable depreciation based upon actual use) upon return of the goods at customer's risk and expense. Miller's option of repair or replacement will be F.O.B., Factory at Appleton, Wisconsin, or F.O.B. at a Miller authorized service facility as determined by Miller. Therefore no compensation or reimbursement for transportation costs of any kind will be allowed.

TO THE EXTENT PERMITTED BY LAW, THE REMEDIES PROVIDED HEREIN ARE THE SOLE AND EXCLUSIVE REMEDIES. IN NO EVENT SHALL MILLER BE LIABLE FOR DIRECT, INDIRECT, SPECIAL, INCIDENTAL OR CONSEQUENTIAL DAMAGES (INCLUDING LOSS OF PROFIT), WHETHER BASED ON CONTRACT, TORT OR ANY OTHER LEGAL THEORY.

ANY EXPRESS WARRANTY NOT PROVIDED HEREIN AND ANY IMPLIED WARRANTY, GUARANTY OR REPRESENTATION AS TO PERFORMANCE, AND ANY REMEDY FOR BREACH OF CONTRACT TORT OR ANY OTHER LEGAL THEORY WHICH, BUT FOR THIS PROVISION, MIGHT ARISE BY IMPLICATION, OPERATION OF LAW, CUSTOM OF TRADE OR COURSE OF DEALING, INCLUDING ANY IMPLIED WARRANTY OF MERCHANTABILITY OR FITNESS FOR PARTICULAR PURPOSE, WITH RESPECT TO ANY AND ALL EQUIPMENT FURNISHED BY MILLER IS EXCLUDED AND DISCLAIMED BY MILLER.

Some states in the U.S.A. do not allow limitations of how long an implied warranty lasts, or the exclusion of incidental, indirect, special or consequential damages, so the above limitation or exclusion may not apply to you. This warranty provides specific legal rights, and other rights may be available, but may vary from state to state.

In Canada, legislation in some provinces provides for certain additional warranties or remedies other than as stated herein, and to the extent that they may not be waived, the limitations and exclusions set out above may not apply. This Limited Warranty provides specific legal rights, and other rights may be available, but may vary from province to province.





# Owner's Record

Please complete and retain with your personal records.

Model Name

Serial/Style Number

Purchase Date

(Date which equipment was delivered to original customer.)

Distributor

Address

City

State

Zip



## For Service

Contact a **DISTRIBUTOR** or **SERVICE AGENCY** near you.

Always provide Model Name and Serial/Style Number.

Contact your Distributor for:

Welding Supplies and Consumables

Options and Accessories

Personal Safety Equipment

Service and Repair

Replacement Parts

Training (Schools, Videos, Books)

Technical Manuals (Servicing Information and Parts)

Circuit Diagrams

Welding Process Handbooks

To locate a Distributor or Service Agency visit [www.millerwelds.com](http://www.millerwelds.com) or call 1-800-4-A-Miller

Contact the Delivering Carrier to:

File a claim for loss or damage during shipment.

For assistance in filing or settling claims, contact your distributor and/or equipment manufacturer's Transportation Department.

### Miller Electric Mfg. Co.

An Illinois Tool Works Company  
1635 West Spencer Street  
Appleton, WI 54914 USA

### International Headquarters—USA

USA Phone: 920-735-4505 Auto-Attended  
USA & Canada FAX: 920-735-4134  
International FAX: 920-735-4125

For International Locations Visit  
[www.MillerWelds.com](http://www.MillerWelds.com)

