



**RapidFix™**  
**SATELLITE<sub>2</sub> 406™**

## Product Support Manual

### Emergency Position Indicating Radio Beacon (EPIRB)

RLB-33  
RLB-32

Y1-03-0148-2  
Rev. H

FCC ID: B668L2ACR-RLB-33  
B668L2ACR-RLB-32

OWNER _____
VESSEL _____
CALL SIGN / MMSI _____
SERIAL NUMBER _____

ACR Electronics, Inc.  
5757 Ravenswood Road  
Fort Lauderdale, FL 33312  
Tel : +1 (954) 981-3333  
Fax: +1 (954) 983-5087  
www.acrelectronics.com  
Email: info@acrelectronics.com

**\* \* \* WARNING \* \* \***

**THIS TRANSMITTER IS AUTHORIZED FOR USE  
ONLY DURING SITUATIONS OF GRAVE  
AND IMMINENT DANGER**

---

**DELIBERATE MISUSE MAY INCUR A SEVERE PENALTY**



**Magnet Safe Distance  
1m (3.3 ft)**

Keep this beacon a safe distance  
away from all magnetic sources



**Stereo Speaker Safe Distance  
1m (3.3 ft)**

Keep this beacon a safe distance  
away from all stereo speakers



**IF YOU HAVE ANY TROUBLE WITH  
YOUR NEW 406 BEACON, DO NOT  
RETURN IT TO THE STORE!  
CALL ACR ELECTRONICS AT  
+1 (800) 432-0227. WE WILL HELP YOU  
RESOLVE ANY PROBLEMS YOU MY BE  
EXPERIENCING. MANY QUESTIONS CAN  
BE ANSWERED OVER THE PHONE.**

---

**LIMITED WARRANTY**

This product is warranted against factory defect in material and workmanship for a period of five years from date of purchase or receipt as a gift. During the warranty period ACR Electronics, Inc. will repair or, at its option, replace at no cost to you for labor, materials or return transportation, provided you obtain a Return Authorization from ACR Electronics, Inc., 5757 Ravenswood Road, Ft. Lauderdale, Fl. 33312-6645. To obtain a Return Authorization, call our Customer Service Department at (800) 432-0227. This warranty does not apply if the product has been damaged by accident or misuse, or as a result of service or modification by other than the factory. Except as otherwise expressly stated, the COMPANY MAKES NO REPRESENTATION OR WARRANTY OF ANY KIND, EXPRESS OR IMPLIED, AS TO MERCHANTABILITY, FITNESS FOR A PARTICULAR PURPOSE, OR ANY OTHER MATTER WITH RESPECT TO THIS PRODUCT. The Company shall not be liable for, consequential or special damages.

In order to place the warranty in effect, the accompanying registration card must be returned to us within ten days of purchase.

## Table of Contents

<b>SECTION 1 – FOREWORD AND PRODUCT FEATURES</b> .....	1
<b>SECTION 2 – REGISTRATION OF 406 MHZ BEACONS</b> .....	1
2.1 Registration Importance .....	1
2.2 Where to Register .....	1
2.3 Registration in the United States .....	2
2.4 Leisure Vessels in the United States.....	2
2.5 Commercial Vessels in the United States.....	2
2.6 Do I Need a Radio Station License? .....	2
2.7 Commercial Vessels World Wide.....	3
2.8 Registration Outside the United States.....	3
2.9 Change of Ownership or Contact Information .....	3
2.10 Lost or Stolen EPIRBs .....	3
<b>SECTION 3 – FALSE ALARMS</b> .....	3
3.1 Prevention of False Alarms .....	3
3.2 Reporting of False Alarms.....	4
<b>SECTION 4 – INSTALLATION</b> .....	4
4.1 Mounting Location .....	4
4.2 Visual Inspection .....	4
4.3 Hydrostatic Release Unit (HRU).....	5
<b>SECTION 5 – ACTIVATION AND DEPLOYMENT</b> .....	6
5.1 Bracket Configuration.....	6
5.2 Dimension Drawings .....	7
5.3 Configuration Overview .....	9
5.4 GPS Acquisition with the RapidFix™ (External GPS) .....	9
5.5 Automatic Deployment and Activation - Category 1 Beacons .....	9
5.6 Manual Deployment and Activation.....	9
5.7 Manual Activation without Deployment .....	10
5.8 Deactivation .....	10
5.9 Full Functional Self Test.....	10
5.10 External GPS Interface: RapidFix™ Only.....	11
<b>SECTION 6 – CARE AND MAINTENANCE</b> .....	12
6.1 Routine Maintenance .....	12
6.2 Battery Replacement.....	12
6.3 Shore Based Maintenance (SBM) for SOLAS Vessels, IMO MSC/Circ. 1039 .....	13
6.4 Annual Testing for SOLAS Vessels, IMO MSC/Circ. 1040.....	13
<b>SECTION 7 – THE SEARCH AND RESCUE SYSTEM</b> .....	13
7.1 General Overview .....	13
7.2 Satellite Detection .....	13
7.3 Global Positioning System (GPS).....	14
<b>SECTION 8 – TECHNICAL INFORMATION</b> .....	14
8.1 Type Approvals and Standards .....	14
8.2 Characteristics.....	15
8.3 Accessories .....	15
8.4 Specifications .....	16

## SECTION 1 – FOREWORD AND PRODUCT FEATURES

Thank you for purchasing from ACR Electronics, Inc. We design, manufacture and distribute quality products knowing they are used to save lives. Many of our products are required to be tested and approved by regulatory bodies worldwide. We believe in going beyond those specifications to insure our products work when needed in real world conditions. With proper care and maintenance your ACR product will last for years. It is important that you thoroughly read this product support manual to understand the proper care and use of your ACR product.

ACR is proud to be certified to ISO 9001: 2000, the International Standard for Quality.

This manual provides installation, operation and maintenance instructions for the RapidFix™ or Satellite<sub>2</sub> 406™ EPIRB, hereinafter referred to as the beacon except where features and functions vary. This manual also describes the characteristics and details of the beacon system. In the USA, the FCC authorizes the use of 406 MHz Radio beacon by any ship that is also equipped with a VHF ship station. This will make the 406 MHz radio beacon available for use on most U.S. ships and boats. Commercial EPIRB carriage requirements are contained in IMO and/or USCG regulations.

Product	Model Number	Product Number	Category	Class	GPS Interface
RapidFix™	RLB-33	2776	1	1	External
RapidFix™	RLB-33	2777	2	1	External
Satellite <sub>2</sub> 406™	RLB-32	2774	1	1	None
Satellite <sub>2</sub> 406™	RLB-32	2775	2	1	None

**NOTE: YOUR BEACON MAY NOT HAVE ALL OF THE FEATURES DESCRIBED IN THIS MANUAL.**

## SECTION 2 – REGISTRATION OF 406 MHZ BEACONS

### 2.1 Registration Importance

It is mandatory that the owner of this 406 MHz beacon register it with the national authority.\* All 406 MHz beacons transmit a Unique Identifier Number (UIN) when activated. This UIN is programmed in the beacon based on the country in which the beacon was purchased. Registration provides the Search and Rescue (SAR) forces with up to date emergency contact information, which will speed up the launch of a rescue operation. The national authorities use the information to verify if an actual emergency exists. Valuable search and rescue resources are wasted every year responding to false alarms. SAR forces will know who you are, what type of vessel you have, your homeport, and who to contact that might know of your current situation ONLY if your beacon has been properly registered. This will help expedite the launch of a rescue operation. All 406 MHz beacons are required to have their registration updated every two years.

\*The national authority is the governmental body responsible for EPIRB registration database administration for the country for which the EPIRB is programmed.

### 2.2 Where to Register

The owner of a 406 MHz beacon (EPIRB) should register it with the national authority for which the beacon was programmed (typically the country where purchased), regardless of where they do their boating. However, the beacon must be reprogrammed if the boat or its owner moves or sails under a different national authority than the one for which the beacon was previously programmed. Each beacon is programmed with a Unique Identification Number (UIN) for the country that the unit is shipped to, and will only be accepted for registration in that country. To verify the country, for which a beacon is programmed, see the label with the UIN on the side of the unit. Units that do not have a country specified on the UIN label are programmed for the United States.

### 2.3 Registration in the United States

It is the owner's responsibility to register 406 MHz beacons that are programmed for and purchased in the United States. The national authority that accepts registrations in the United States is the National Oceanic and Atmospheric Administration (NOAA). The fastest and easiest way to register your beacon with NOAA is to use the online registration database at [www.beaconregistration.noaa.gov](http://www.beaconregistration.noaa.gov). If internet is not accessible then the owner should complete the enclosed registration form (Do not confuse this with the ACR Electronics warranty card) and mail with the pre-addressed, postage paid envelope to:

**NOAA SARSAT Beacon Registration  
NSOF, E/SP3  
4231 Suitland Road  
Suitland, MD 20746**

**For Faster Service, Register Online!  
In the United States:  
[www.beaconregistration.noaa.gov](http://www.beaconregistration.noaa.gov)**

The information provided on the registration form is used only for rescue purposes. Complete and send the registration **immediately!** Registration can be expedited by registering online or by faxing the registration form to Fax # (301) 817-4565. If the beacon is going to be placed into immediate service, register online or by fax. All registration forms will be entered in the 406 MHz beacon registration database within 48 hours of receipt. A confirmation letter, a copy of the actual registration and a proof-of-registration decal will be mailed to you within two weeks. When you receive these documents, **please check the information carefully** and affix the decal to your beacon in the area marked "BEACON DECAL HERE." If you do not receive confirmation back from NOAA, call toll-free 1-888-212-7283 for assistance.

### 2.4 Leisure Vessels in the United States

In the United States, leisure vessels are sometimes required to have a radio station license. Leisure vessels that are required to have a radio station license are required to modify that license when an EPIRB is added to the vessel. For information on whether you need a radio station license, see section 2.6 (below).

### 2.5 Commercial Vessels in the United States

In the United States, commercial vessels that are required to have a radio station license are required to modify that license when an EPIRB is added to the vessel. For information on whether you need a radio station license, see section 2.6 (below).

### 2.6 Do I Need a Radio Station License?

The information in this section is provided for informational purposes only. Always check the FCC's website at [http://wireless.fcc.gov/services/index.htm?job=licensing&id=ship\\_stations](http://wireless.fcc.gov/services/index.htm?job=licensing&id=ship_stations) or call toll-free 1-888-CALLFCC (225-5322) for the latest information.

You do not need a license to operate a marine VHF radio, radar, or EPIRBs aboard voluntary ships operating domestically. The term "voluntary ships" refers to ships that are not required by law to carry a radio. Generally, this term applies to recreation or pleasure craft. The term "voluntary ships" does not apply to the following:

1. Cargo ships over 300 gross tons navigating in the open sea;
2. Ships certified by the U.S. Coast Guard to carry more than 6 passengers for hire in the open sea or tidewaters of the U.S.;
3. Power driven ships over 20 meters in length on navigable waterways;
4. Ships of more than 100 gross tons certified by the U.S. Coast Guard to carry at least one passenger on navigable waterways;
5. Tow boats of more than 7.8 meters in length on navigable waterways; and,
6. Uninspected commercial fishing industry vessels required to carry a VHF radio.
7. Ships required to carry an Automatic Identification System (AIS) transceiver by the U.S. Coast Guard regulations enacted pursuant to the Maritime Transportation Security Act of 2000.

Ships are considered as operating domestically when they do not travel to foreign ports or do not transmit radio communications to foreign stations. Sailing in international waters is permitted, so long as the previous conditions are met. If you travel to a foreign port (e.g., Canada, Mexico, Bahamas, British Virgin Islands), a license is required. Additionally, if you travel to a foreign port, you are required to have an operator permit.

## 2.7 Commercial Vessels World Wide

406 MHz beacons that are carried on commercial vessels world wide should be registered with the country where the vessel is flagged regardless of where the vessel operates. When a commercial vessel acquires a 406 MHz beacon from outside of its home country, the beacon should be reprogrammed for the home country and registered there.

## 2.8 Registration Outside the United States

In countries other than the United States, 406 MHz beacons are registered with that country's national authority at the time of purchase. The sales agent should assist in filling out the forms and sending to that country's national authority. To verify that the unit is properly programmed for that country, view the UIN label on the side of the unit. In the event that the beacon is not programmed for the country it has been purchased in, the sales agent, (if properly equipped) can reprogram the unit for that country.

## 2.9 Change of Ownership or Contact Information

It is the owner's responsibility to advise the national authority of any change in the information on the registration form. If the current owner of the beacon is transferring the beacon to a new owner, the current owner is required to inform the national authority by using their online database or by letter, fax or telephone, of the name and address of the new owner. The new owner of the beacon is required to provide the national authority with all of the information requested on the registration form. This obligation transfers to all subsequent owners. Registration forms for the United States are available from NOAA by calling 1 (888) 212-7283 or by visiting our website at [www.acrelectronics.com](http://www.acrelectronics.com).

## 2.10 Lost or Stolen EPIRBs

Inform NOAA immediately at 1-888-212-SAVE (7283), or your national authority, that your EPIRB has been lost or stolen. They will update your EPIRB registration information with the appropriate information.

### **Stolen EPIRBs - Things That You Need To Do:**

- Report to your local authorities that the EPIRB has been stolen.
- Contact NOAA at 1-888-212-SAVE (7283), or your national authority, with the following information so your EPIRB registration information can be updated with the appropriate remarks:
  - Police Department Name - Police Phone Number - Police Case Number

If your EPIRB were to be activated, the information you provided will be forwarded to the appropriate search and rescue authorities who will ensure that your EPIRB gets back to you. If someone attempts to register an EPIRB reported as stolen, NOAA or your national authority will notify the appropriate police department. Visit [www.cospas-sarsat.org](http://www.cospas-sarsat.org) for more detailed information.

## SECTION 3 – FALSE ALARMS

### 3.1 Prevention of False Alarms

An ACR 406 MHz EPIRB can be activated in an emergency by two different methods. Whether you have a Category 1 or 2, these methods are the same.

1. When the beacon is out of its bracket and in the water, the unit will start transmitting.
2. When the switch is moved to the "ON" position, in or out of the bracket, the unit will start transmitting.
- 3.

There are a few precautions that should be taken to prevent false alarms.

- **Do not mount or transport beacon within 3.3 ft/1 m of a magnetic source.**
- **Do not store beacon outside of its bracket if it can get wet.**
- **Do not mount EPIRB backwards in its bracket (lanyard roll must not be visible).**
- **Do not clean beacon with a water hose and brush while out of its bracket.**

### 3.2 Reporting of False Alarms

Should there be, for any reason, an inadvertent activation or false alarm, **it must be reported to the nearest search and rescue authorities**. The information that should be reported includes the EPIRB 15-digit Unique Identifier Number (UIN), date, time, duration and cause of activation, as well as location of beacon at the time of activation.

**To Report False Alarms in the United States Contact any of the Following:**

**Atlantic Ocean / Gulf of Mexico**  
**USCG Atlantic Area Command Center** Tel: (757) 398-6390

**Pacific Ocean Area /**  
**USCG Area Command Center** Tel: (510) 437-3700

**USCG HQ Command Center** Tel: (800) 323-7233

**To Report False Alarms Worldwide contact the national authority where your beacon is registered.**

## SECTION 4 – INSTALLATION

### 4.1 Mounting Location

The location selected must be sufficiently rigid to support the weight of the total installation and at the same time consider vibration, exposure to the elements, exposure to surrounding hazards, such as equipment movement, doors being opened, accidental covering, personnel traffic, etc., and yet be readily accessible at all times in the event of an emergency.

Also to be considered in selecting a location for installation is the harmful effect that certain corrosive vapors might have on the beacon. Under no circumstances should a beacon be jeopardized by any foreign articles being temporarily or permanently positioned during “at sea” or “in port” activities.

The beacon should face inboard on rail mount applications and should not be subjected to breaking waves.

**CAUTION:** Care must be taken to prevent any lanyard, line, or other emergency equipment that may be attached to the beacon from becoming entangled or fouled which could prevent the beacon from being removed in an emergency. **Do not attach the beacon lanyard to the vessel or mounting bracket.**

Do not mount the beacon in the vicinity 3.3 ft/1 m of strong magnetic or electrical fields, such as loud speakers, radar or high power radio transmitter. The beacon should not be mounted closer than 3.3 ft/1 m. to a magnetic navigation compass.

Mount the beacon in a vertical (antenna upward) position. In certain circumstances, such as medical emergencies or disabled vessels, manual activation of the beacon for location and homing purposes is sometimes requested. Mounting in this orientation provides the best homing signal.

The Category 1 float-free mounting bracket should be mounted securely to a *vertical or horizontal surface* (the mount has predrilled holes for attachment to a flat surface) where there are no overhead obstructions. Location aboard a vessel must be chosen to allow the beacon to float free of sinking craft and as high as possible, especially on small vessels. This will help ensure operation of the hydrostatic release unit in the event the vessel capsizes without sinking. See section 4.3 on removing the HRU.

The Category 1 float-free mounting bracket should be securely attached to the vessel. The use of #10 stainless steel hardware (not included) is recommended.

### 4.2 Visual Inspection

Visually inspect the area surrounding the mounting bracket installation site for hidden hazards, obstacles, etc., that may have been overlooked during location selection. If there is any doubt as to the ready accessibility to the beacon at all times or if any condition may appear to be questionable, make a complete and thorough investigation before making final approval of the installation.

### 4.3 Hydrostatic Release Unit (HRU)

The ACR HydroFix™ HRU has an expiration date of 2 years from the date of installation or 3 years from the date manufactured, whichever comes first. **Upon installing your beacon or new HRU, permanently scratch the new expiration date on the HRU date calendar** (as seen below).

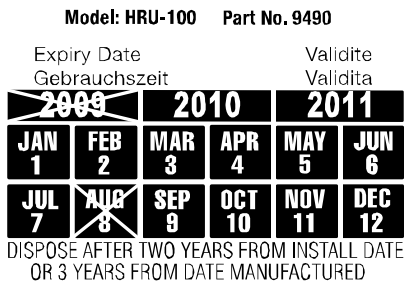

Figure 1 HRU Date Calendar

#### Date of Installation Example:

Date of installation of New HRU or First Installation of EPIRB including new HRU: **August 1, 2007.**

This unit will need to be replaced in **August of 2009.** Scratch off "AUG 8" and "2006" on the HRU date calendar

#### Date of Manufacture Example:

On the bottom of the HRU a date of manufacture is pin stamped: **0806.**

This unit will need to be replaced in **0809.** Scratch off "AUG 8" and "2009" on the HRU date calendar

The hydrostatic release can be replaced by removing the beacon from the bracket. Firmly press down on the spring at the bottom of the shelter, then slide the hydrostatic release assembly out of the keyed opening on the spring and mounting bracket. Discard the old HRU. Check the date manufactured on the bottom of the new HRU and insert the new hydrostatic release assembly in place by engaging it to the opening of the ejection spring and case. When replacing the HRU, ACR requires that you **do not reuse any parts from the previous HRU.** Failure to replace the entire assembly can cause the bracket to malfunction. Always use original ACR replacement parts (**Replacement kit P/N 9490**). Use of unauthorized replacement parts will void your warranty and may cause the bracket to malfunction. Place the beacon into the mounting bracket, (lanyard facing inward), and replace cover, securing in place with the cotter pin going through the hydrostatic release rod.



## SECTION 5 – ACTIVATION AND DEPLOYMENT

### 5.1 Bracket Configuration

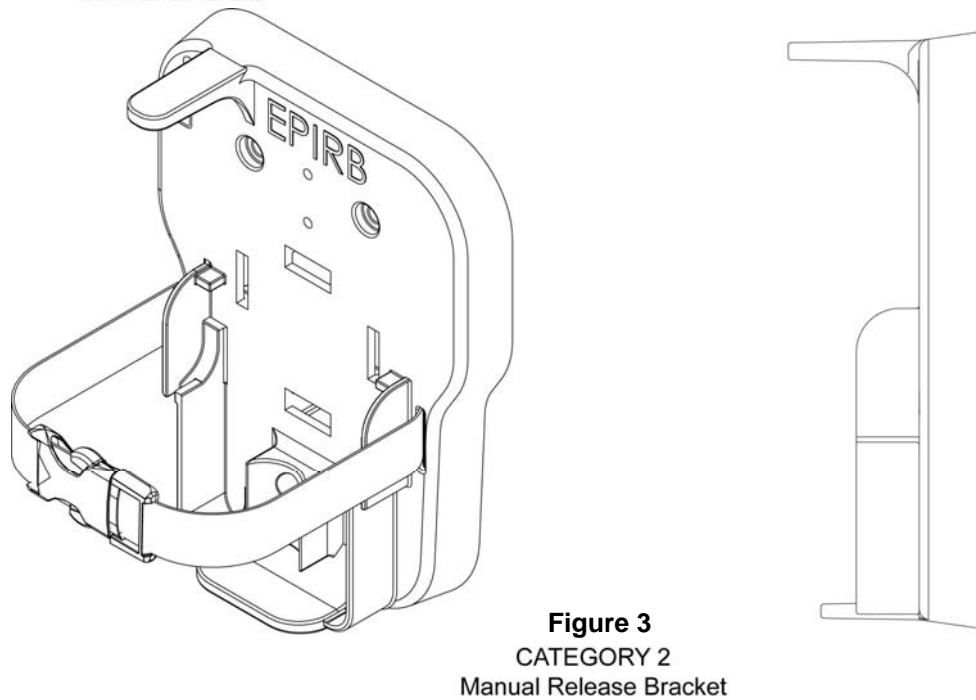
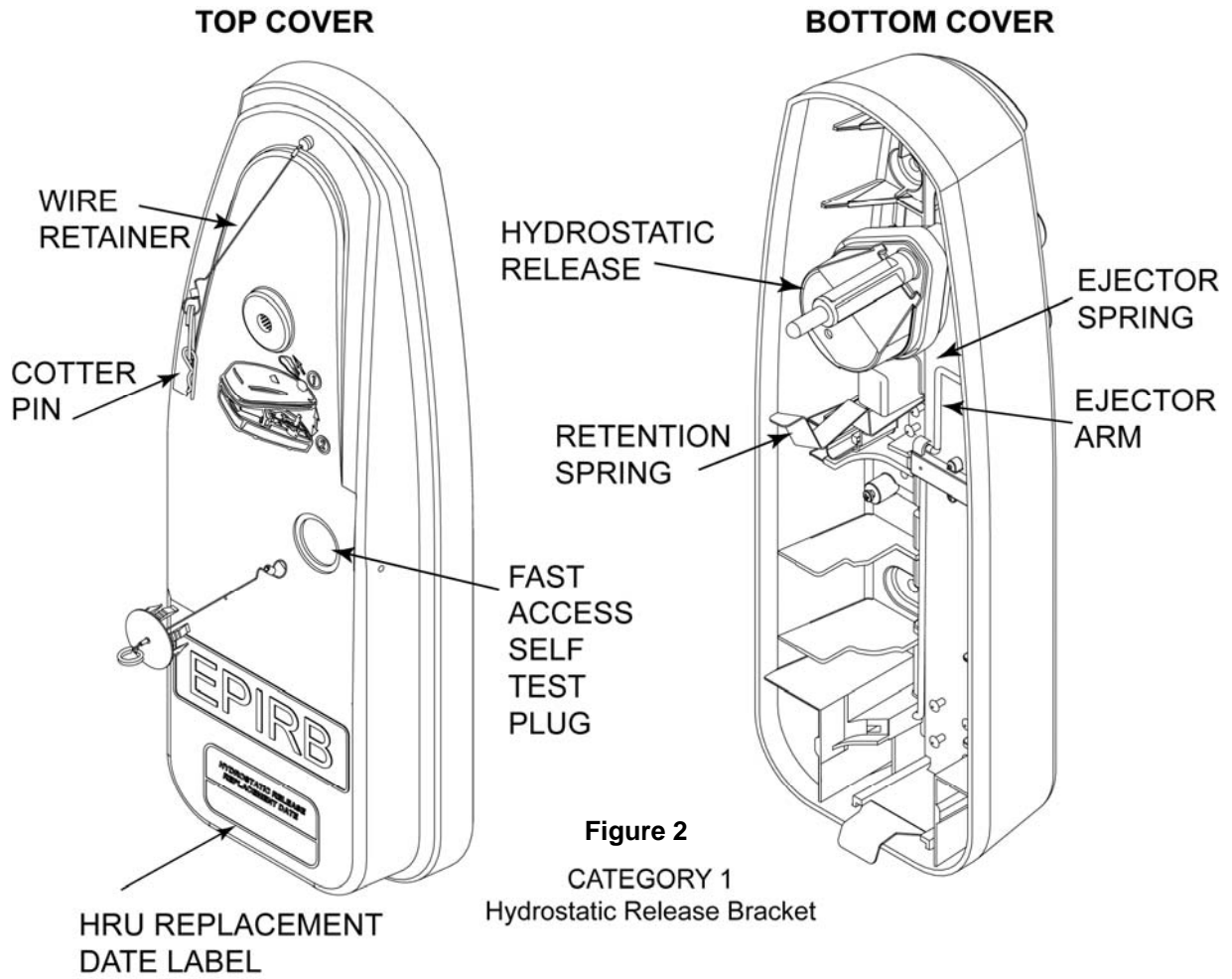

## 5.2 Dimension Drawings

Category 1 Dimension Drawing  
NOT TO SCALE

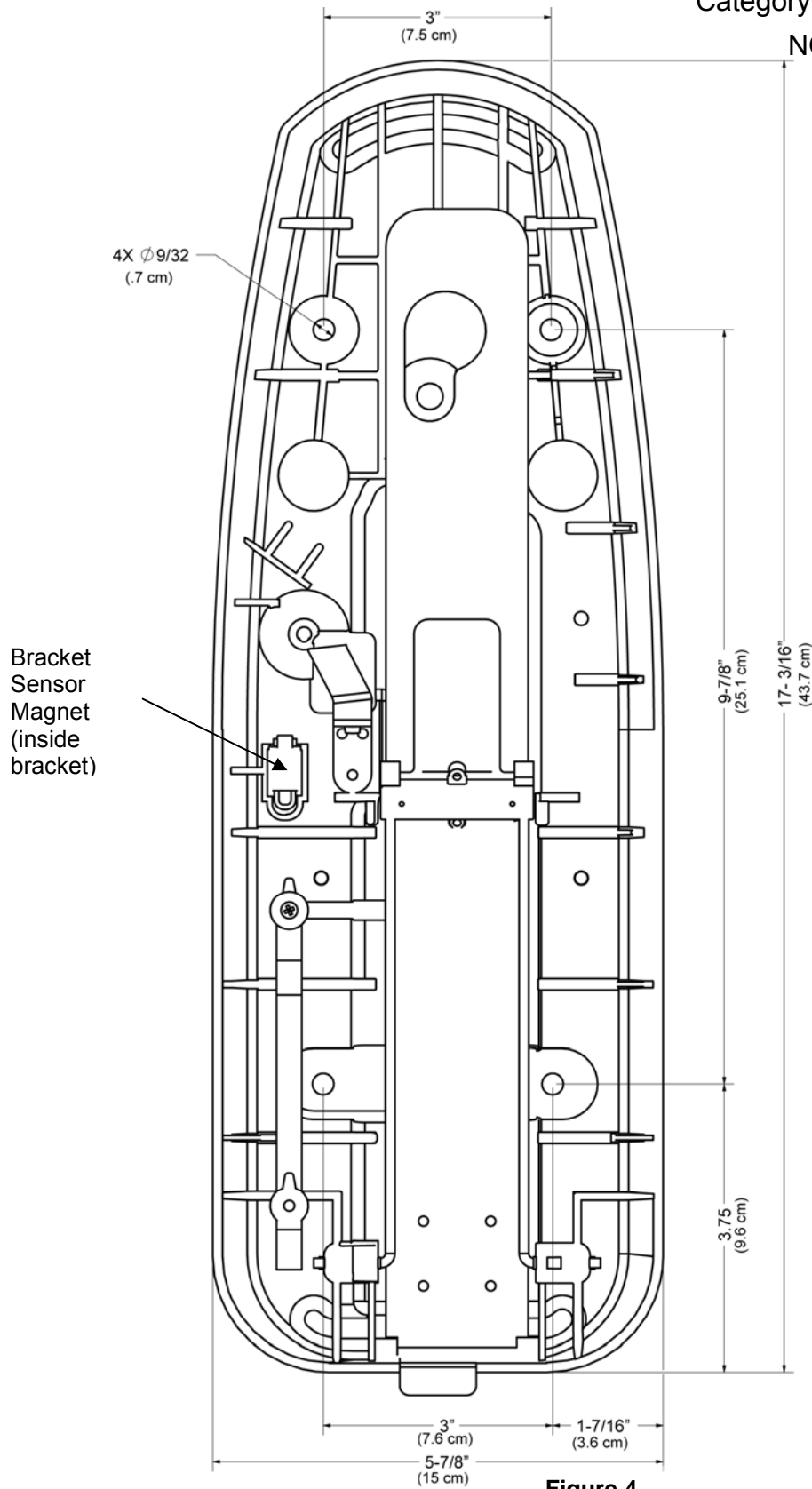

Figure 4

Category 2 Dimension Drawing  
NOT TO SCALE

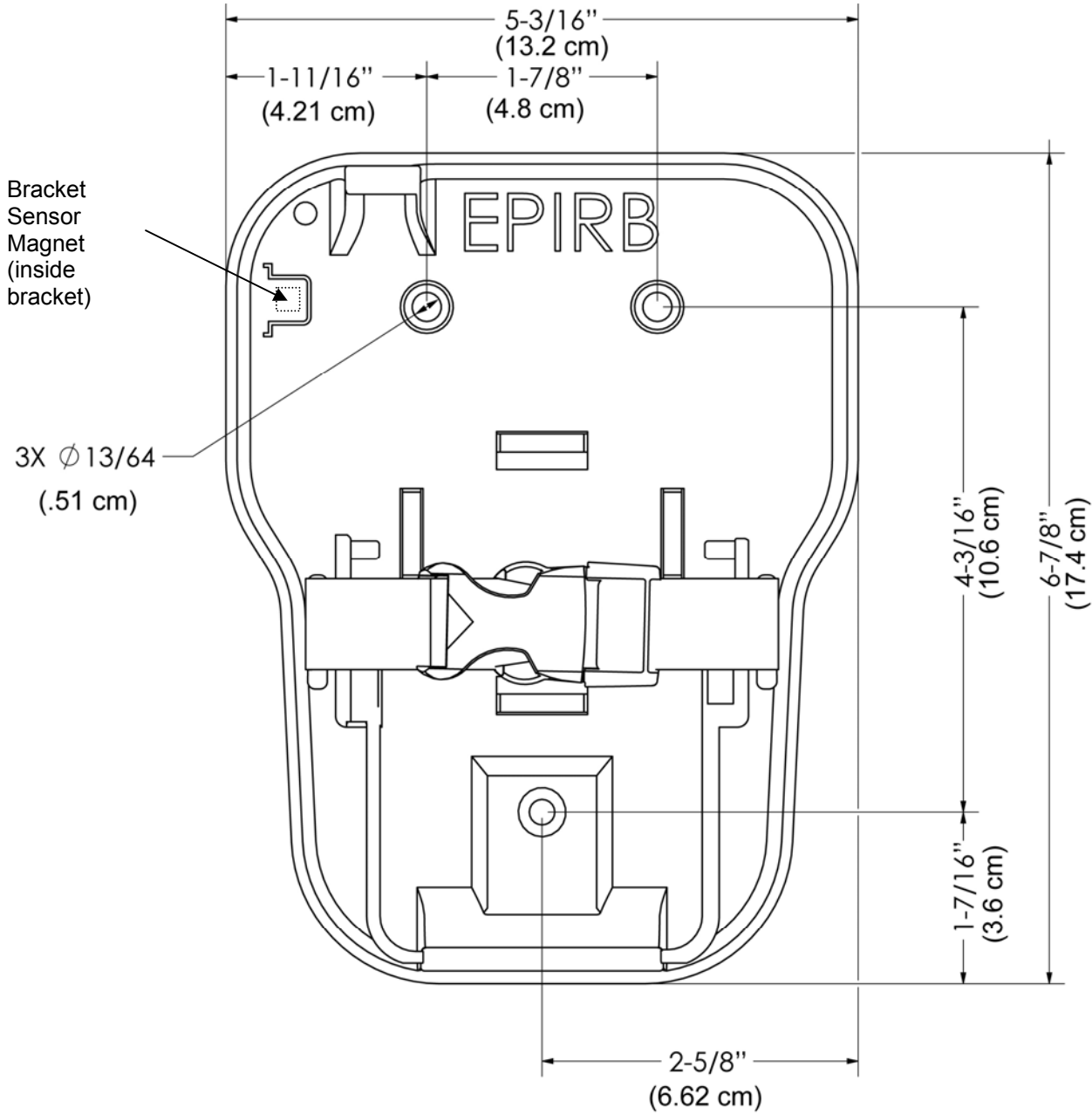

Figure 5

### 5.3 Configuration Overview

Category 1 beacons are designed to be automatically deployed and activated. The beacon may also be hand held on the deck of vessels, or floated in water and attached to a raft or life vest with the lanyard provided. Category 2 beacons are designed to be manually deployed from the bracket.

The **beacon is designed to operate best while floating in water**. Hand held operation should be avoided when possible. Do not operate inside life raft or under any similar cover or canopy. Use the lanyard to attach beacon to life raft or person after deployment. **Caution** - *Do not attach lanyard to bracket or vessel*. Both models of the beacon can be deployed and activated manually.

Changes in the laws governing beacons have mandated that the beacon be ready at all times. If certain criteria are met, the beacon will begin transmitting. The beacon is equipped with sensors to determine if it is in water (a deployment condition). Category 1 and 2 brackets both contain a magnet that interacts with other sensors in the beacon to prevent activation if it is wet (also a deployment condition).

Two conditions must be satisfied for the beacon to automatically activate:

- 1) **It must be out of its bracket**
- 2) **It must be in the water**

Note: Either condition by itself will *not* automatically activate the beacon.

The beacon is designed to allow the user to perform periodic testing while the beacon is in the release bracket.

**Category 1:** Place the beacon into the release bracket with the spooled lanyard inward. The beacon should now be firmly held in the Category 1 bracket and ready for automatic deployment. Do not attach lanyard to bracket.

**Category 2:** Place the beacon into the bracket with the spooled lanyard inward. The beacon should now be firmly held in the Category 2 bracket and ready for manual deployment. Do not attach lanyard to bracket. Use the strap and buckle to secure the beacon. The strap should be adjusted tight against the beacon; tight enough so that it is almost difficult to engage the buckle. This should be checked periodically.

### 5.4 GPS Acquisition with the RapidFix™ (External GPS)

The RapidFix™ is fitted with an optical interface to connect with an **external** Global Positioning System receiver that will determine the latitude and longitude of its position to be transmitted to the emergency system. When the RapidFix™ is coupled to a working external GPS receiver, it immediately begins downloading data. Once valid position data has been obtained, the beacon will attempt to update the positional data every 20 minutes. The RapidFix™ will always store the last valid positional data it received from the external GPS receiver, even if it is unable to obtain updated data. It will update this data if and only if it receives new good positional data from the external GPS receiver.

### 5.5 Automatic Deployment and Activation - Category 1 Beacons

Automatic deployment and activation occurs if the vessel sinks and the hydrostatic release device frees the beacon from the bracket allowing it to float to the surface. Built-in sensors detect that the beacon is no longer in its bracket and is in water. This condition will automatically activate the beacon.

**NOTE: TRANSMISSIONS OF THE 121.5 MHZ AND 406 MHZ SIGNAL WILL NOT OCCUR UNTIL 50 SECONDS AFTER ACTIVATION.**

### 5.6 Manual Deployment and Activation

The Category 1 beacon can be manually deployed by removing the retaining pin, removing the cover, and then removing the beacon from the bracket. Once removed, both the Category 1 and Category 2 beacons can be activated by placing the beacon in water OR by lifting the thumb switch to a vertical position, sliding it toward the antenna and pushing down to the opposite side of the beacon. Activating the beacon in this manner breaks off the Activation Indicator Plastic Pin and allows the switch to properly seat, showing the "■" symbol (ON).

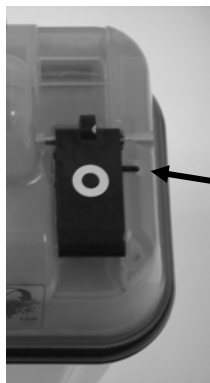

**OFF position:**  
Note the  
Activation  
Indicator  
Plastic Pin

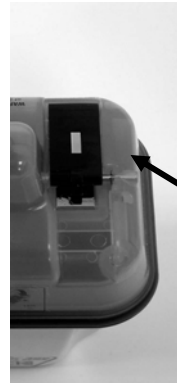

**ON position:**  
Notice the  
Activation  
Indicator  
Plastic Pin  
has been  
broken off.

**Figure 6**

Note: Some countries may fine vessel owners for causing false alarms. The permanent breakage of the Activation Indicator Plastic Pin is a positive indication of a manual activation.

**5.7 Manual Activation without Deployment**

The beacon can be activated while still in its bracket by placing the thumb switch in the ON position. Activation by this method overrides all sensors and turns the beacon “ON.” The caution note above still applies.

**5.8 Deactivation**

If **manually activated**, return the thumb switch to the “OFF” position.

If **automatically activated**: remove the beacon from the water. The beacon normally takes up to 12 seconds to deactivate, or place the beacon back into the release bracket.

If the beacon continues to operate after it has been deactivated, remove the four screws holding the unit together and unplug the battery to disable the unit. Return it to a service center for repair.

**5.9 Full Functional Self Test**

**General Instructions**

Please read all instructions before performing any of the tests. Be prepared to record data from the test. Beacons may be tested in or out of the release bracket. The homing beacon at 121.5 MHz is inhibited during self test. It is strongly recommended to perform the full functional self test on the beacon on a monthly basis or prior to a voyage.

The self-test is initiated by momentarily lifting the thumb switch to a vertical position and holding it in this position for at least one second (see figure 7). The initiation of the test is indicated by a beep\* and the simultaneous lighting of the green and red LEDs.



**Figure 7**

TEST	SUCCESS	FAIL
Initial Test Start	🟢🔴 Green, Red LED	
Check Data Integrity	Beep, 🟢🔴 Green, Red LED	Test stopped
Check 406 MHz Synthesizer	Beep, 🟢🔴 Green, Red LED	Test stopped
Check RF Power/Battery	Beep, 🟢🔴 Green, Red LED	Test stopped
Successful Test	🟢 Green LED, Strobe	

\*NOTE: The “beeps” are a very high-pitched tone that many people may not be able to hear.

If the thumb switch is accidentally or inadvertently put in the vertical or test position (not in the OFF or ON position), the beacon would still be turned ON and will drain the battery. It is very unlikely that this would happen, however, if this should occur, the beacon will sound a beep once per second and will alternately flash the red and green LEDs at a rate of one per second until the beacon is turned OFF. It is important that the beacon be turned OFF immediately by lowering the thumb switch to the OFF position (thumb switch at rest in the front position) if this alert is ever obtained.

### Category 1 Self Test Plug

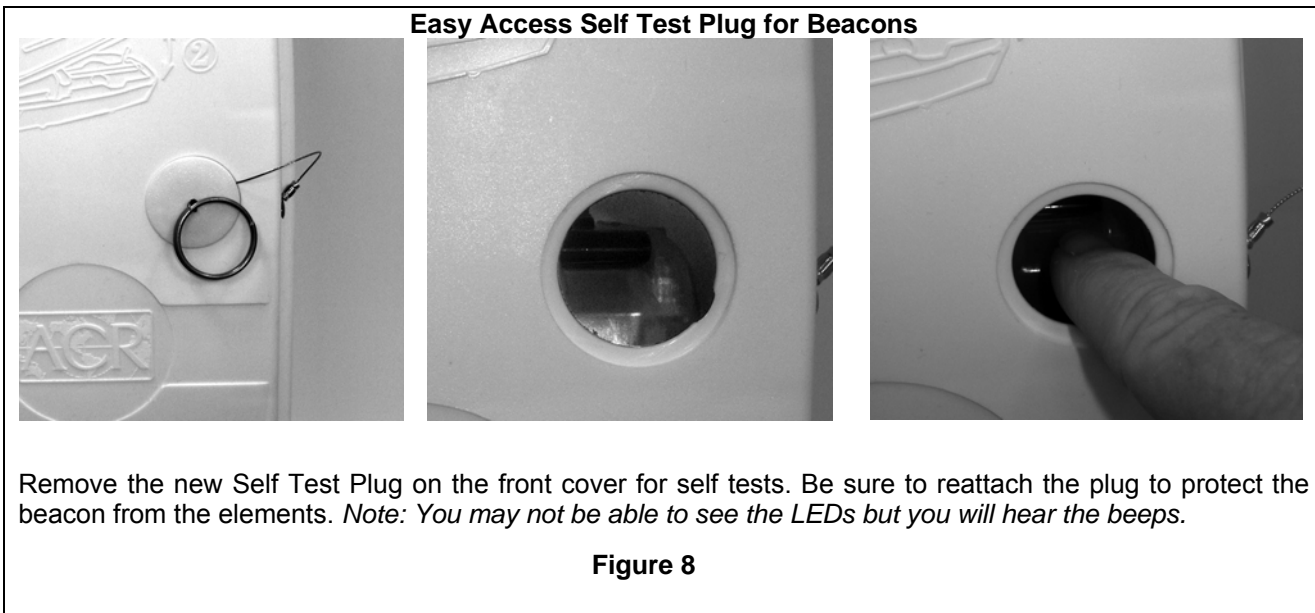

### 5.10 External GPS Interface: RapidFix™ Only

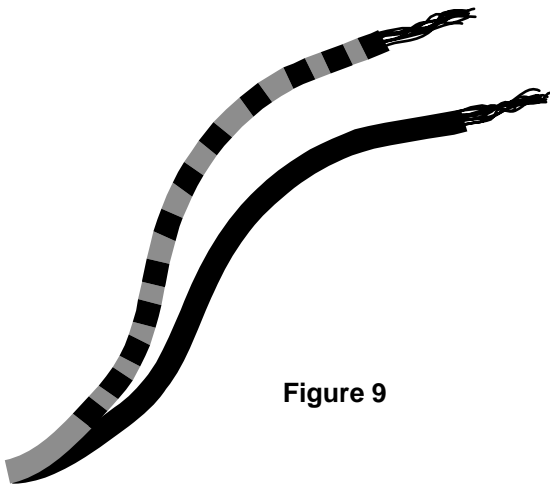

Your RapidFix™ comes with a GPS Optical Interface (transmitter plug with lead wires) and a keyed GPS bezel. The transmitter plug attaches to your RapidFix™, via the keyed bezel. The GPS Optical Interface lead wires attach to your GPS via the NMEA 0183 connector from your GPS receiver. The black lead wire with gray stripes should be connected to the **positive** transmitter pin. The black wire should be connected to the **negative** pin.

If the external GPS receiver is operational and the connection has been correctly made to the optical interface, the green LED in the optical interface will start flashing.

**Figure 9**

NOTE: The baud rate output for your GPS receiver NMEA 0183 should be 4800 bps. If you are not sure if your receiver is NMEA 0183 compliant, check the interface settings listed in your GPS manual. To optimize your GPS Interface feature be sure that your GPS receiver is equipped with a NMEA 0183 Version 1.5 or higher with GPGLL sentence enabled.

#### Using the GPS Interface

Once a compatible, operating GPS receiver is connected to the RapidFix™, the beacon will store data for incorporation into the emergency message, which is transmitted to the satellite when it is activated in an emergency. This can provide more accurate positioning data to the Search and Rescue Authority and may lead to a faster rescue. Since the last valid GPS position data is always kept in the memory of the RapidFix™, the user should take care to make sure that the GPS position data stored is accurate. This can be

accomplished by two methods: first, by always leaving a properly functioning GPS connected to the RapidFix™ before activation and second, by connecting a properly functioning GPS with a valid position fix and allowing sufficient time to acquire valid GPS position data. This will take a nominal 20 minutes if old GPS position data is stored in the memory of the RapidFix™. If there is no old GPS position data present, the beacon will acquire current data within a minute of being connected to a GPS with a valid position fix. You can force the RapidFix™ to update its position at any time by connecting to a GPS with a valid position fix and initiating the Self-Test (see 5.10). If valid GPS position data is not available, the beacon will not clear the previously stored GPS position data. In this case, call ACR Customer Service at +1 (954) 491-3933 for instructions on how to reset the RapidFix™ with the beacon's default message.

### **Testing the GPS Interface**

Connect the optical interface plug to the RapidFix™ bezel and allow sufficient time for the GPS receiver to acquire valid GPS position data (usually less than 1 minute; but it can take up to 20 minutes). Lift the thumb switch to the vertical (Self-Test) position and release. Your RapidFix™ will confirm that it has acquired valid GPS data by emitting a beep along with a flash of the red and green LEDs. This will occur approximately 2.5 seconds after the Self-Test.

### **Updating GPS Position Data**

When the beacon is properly connected to a functioning and compatible GPS receiver, GPS position data is automatically updated about every 20 minutes, while valid GPS position data is present UNLESS the beacon is activated. The operator can force the acquisition of new GPS position data, by executing a Self-Test with the beacon connected to a GPS with a valid position fix. This bypasses the normal, programmed, waiting time of 20 minutes for the automatic update of GPS position data. Once the RapidFix™ has completed the Self-Test sequence by emitting the beep and flash of red and green LEDs, as described in 5.10, the RapidFix™ will request and acquire new position data from the GPS. This can take a nominal 15 seconds or up to one minute.

NOTE: While the beacon is not activated, GPS position data will be received and continuously stored by the RapidFix™. **No GPS position data updates will occur while the beacon is activated.**

A new RapidFix™ is programmed with the GPS position data set to "default." This default GPS position data indicates, upon activation, to the satellite system that the beacon has no valid GPS position stored in memory. Once a functioning and compatible GPS receiver is properly connected to the beacon, this "default" data will be replaced by valid GPS position data, as described in the previous sections.

## **SECTION 6 – CARE AND MAINTENANCE**

### **6.1 Routine Maintenance**

At least every ninety days, the float free mounting bracket and beacon should be inspected for deterioration and/or residue buildup that may affect the function of the beacon or automatic release. Part of the visual check includes checking the antenna for tightness. Clean the beacon and the mounting bracket to remove residue buildups. It is recommended that the beacon and mounting bracket be wiped with a damp cloth.

Carefully inspect the beacon case for any visible cracks. Cracks may admit moisture, which could falsely activate the beacon or otherwise cause a malfunction. Any cracking observed should be immediately referred to ACR for evaluation by calling 1-800-432-0227 ext. 2155 in the US, or +1-954-981-3333 ext 2155 elsewhere.

### **6.2 Battery Replacement**

The battery must be replaced by the date indicated on the beacon or every five (5) years, whichever occurs first. At each inspection, check the time remaining until replacement is required. The battery should be replaced if the beacon has been activated for any use other than the self test.

Always refer all long life battery replacement and other beacon service to a factory authorized service center. Battery replacement includes servicing the beacon by replacing all o-rings, testing the water seal and the electrical properties.

NOTE: There are no user serviceable items inside the beacon. **DO NOT OPEN THE BEACON UNLESS TO DISABLE IN CASE OF FAULTY ACTIVATION.**

**For the nearest location of a Battery Replacement Center, visit our website at [www.acrelectronics.com](http://www.acrelectronics.com)**

The beacon may or may not require special shipping instructions due to the lithium batteries and changes in shipping regulations. Please refer to ACR's website [www.acrelectronics.com](http://www.acrelectronics.com) for proper shipping instructions.

### **6.3 Shore Based Maintenance (SBM) for SOLAS Vessels, IMO MSC/Circ. 1039**

The Maritime Safety Committee approved guidelines for shore-based maintenance of satellite beacons, for the purpose of establishing standardized procedures and minimum levels of service for the testing and maintenance of satellite beacons. First Shore Based Maintenance on all ACR EPIRBs is due at the date of the first battery replacement.

### **6.4 Annual Testing for SOLAS Vessels, IMO MSC/Circ. 1040**

SOLAS regulation IV/15.9 dictates annual testing of 406 MHz satellite EPIRBs. Testing should be carried out using suitable test equipment capable of performing the relevant measurements. All checks of electrical parameters should be performed in the self-test mode, if possible.

## **SECTION 7 – THE SEARCH AND RESCUE SYSTEM**

### **7.1 General Overview**

Beacons provide distress alerts via radio transmission on 406 MHz to the LEOSAR satellites of the COSPAS-SARSAT network. The RapidFix™ can also transmit a distress alert (acquired by the internal or external GPS) to the GEOSAR network that includes GPS latitude and longitude coordinates.

The message transmitted is unique for each beacon, which provides identification of the transmitter through computer access of registration files maintained by the National Oceanic and Atmospheric Administration or other national authority\*. Remember, SAR forces will know who you are, what type of vessel you have, your homeport, and who to contact that might know of your current situation ONLY if your beacon has been properly registered. This will help expedite the launch of a rescue operation. 406 MHz beacons are required to have their registration updated every two years.

\*The national authority is the governmental body responsible for EPIRB registration database administration for the country for which the EPIRB is programmed.

Once the 406 MHz signal is relayed through the LEOSAR and/or GEOSAR network, SAR forces determine who is closest, and then proceed to the beacon using the 121.5 MHz homing frequency.

### **7.2 Satellite Detection**

EPIRBs transmit to the satellite portion of the COSPAS-SARSAT system. COSPAS-SARSAT is an international system that utilizes Russian Federation and United States' low altitude, near-polar orbiting satellites (LEOSAR). These satellites assist in detecting and locating activated 406 MHz satellite beacons.

COSPAS and SARSAT satellites receive distress signals from EPIRBs transmitting on the frequency of 406 MHz. The COSPAS-SARSAT 406 MHz beacon signal consists of a transmission of non-modulated carriers followed by a digital message format that provides identification data. The 406 MHz system uses Satellite-borne equipment to measure and store the Doppler-shifted frequency along with the beacon's digital data message and time of measurement. This information is transmitted in real time to an earth station called the Local User Terminal (LUT), which may be within the view of the satellite, as well as being stored for later transmission to other LUTs.

The LUT processes the Doppler-shifted signal from the LEOSAR and determines the location of the beacon, then the LUT relays the position of the distress to a Mission Control Center (MCC) where the distress alert and location information is immediately forwarded to an appropriate Rescue Coordination Center (RCC). The RCC dispatches Search and Rescue (SAR) forces.

The addition of the GEOSAR satellite system greatly improves the reaction time for a SAR event. This satellite system has no Doppler capabilities at 406 MHz, but will relay the distress alert to any of the LUT stations. When there is GPS data included in the distress message, SAR authorities instantly know your location to within 110 yards (100 m). This speeds up the reaction time by not having to wait for one of the LEOSAR satellite to pass overhead. Because most of the search and rescue forces presently are not equipped to home in on the 406 MHz Satellite beacons signal, homing must be accomplished at 121.5 MHz.



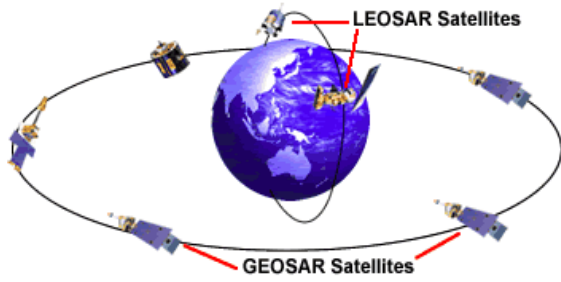

Figure 10- Satellite Coverage

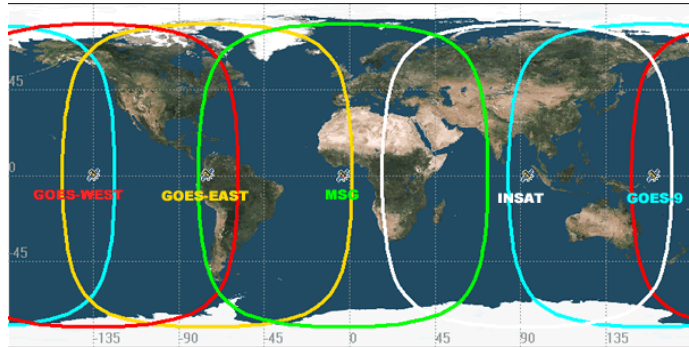

Figure 11- GEOSAR Satellite Orbits

**7.3 Global Positioning System (GPS)**

The GPS system is a satellite group that enables a GPS receiver to determine its exact position to within 30 m (100 ft.) anywhere on earth. With a minimum of 24 GPS satellites orbiting the earth at an altitude of approximately 11,000 miles they provide users with accurate information on position, velocity, and time anywhere in the world and in all weather conditions. The RapidFix™ stores this data into its distress transmission allowing search and rescue forces to narrow the search into a very small area and thus minimize the resources required and dramatically increase the effectiveness of the overall operation.

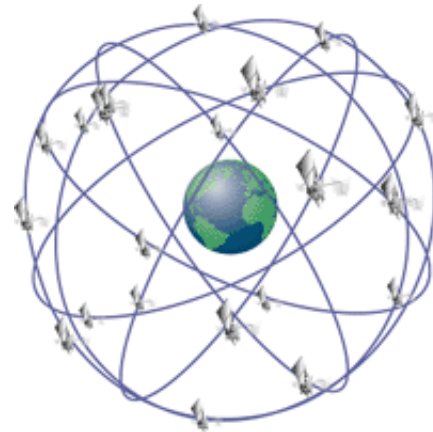

Figure 12 - GPS Satellite Orbits

**SECTION 8 – TECHNICAL INFORMATION**

**8.1 Type Approvals and Standards**

The RLB-32 and RLB-33 meet the requirements of Federal Communication Commission (FCC) Part 80 and Category 1 EPIRBs meet the GMDSS requirements:

Type Approvals	
FCC	FCC ID: B668L2ACR-RLB-33 (RLB-33)
	FCC ID: B668L2ACR-RLB-32 (RLB-32)
COSPAS-SARSAT	Certificate No. 108 (RLB-33)
	Certificate No. 107 (RLB-32)
MED	BSH Certificate No.: 6492/050564-2/2004 (RLB-33)
	BSH Certificate No.: 6492/050564-1/2004 (RLB-32)
	Notified Body: 0735

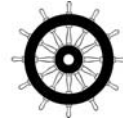

Copies of certificates and additional worldwide type approvals are available at [www.acrelectronics.com](http://www.acrelectronics.com).

Applicable Standards	
FCC	Part 80 Subpart V – EPIRBs
	Part 80 Subpart W – GMDSS (Cat. 1 only)
RTCM	RTCM Recommended Standards for 406 MHz Satellite EPIRBs
COSPAS/SARSAT	C/S T.001 – Specification for C/S 406 MHz Distress Beacons
	C/S T.007 –C/S 406 MHz Distress Beacon Type Approval Standard
MED	Annex A.1, Item No. A.1/5.6 – 406 MHz (C/S) Satellite EPIRB
	Annex B, Model B
IMO	IMO Resolution A.694(17) – General Requirements for GMDSS Equipment
	IMO Resolution A.810(19) – Performance Standards for Float-Free Satellite 406 MHz EPIRBs (Cat. 1 only)

## 8.2 Characteristics

The EPIRB is a buoyant, battery operated unit. The beacon case, with its external antenna, is waterproof. The semiconductor circuits are mounted within the case assembly that also contains the battery power supply. A “Test/ON” switch is installed on top of the beacon, along with a strobe light. The Category 1 beacon must be stored in its special mount, free of obstructions aboard a vessel for automatic float-off. The unit is self-buoyant and no external flotation devices are required.

## 8.3 Accessories

Product	Product Number
<b>Category 1</b> Mounting Case 6.5" x 17.1" (16.51 cm x 43.4 cm)	9455
<b>Category 2</b> Mounting Brackets 6.0" x 7.7" (15.2 cm x 19.5 cm)	9430
<b>Category 1</b> GPS Interface Plug- Rapid Fix	9388.1
<b>Category 2</b> GPS Interface Plug- Rapid Fix	9388
Universal HRU Kit	9490
Replacement Antenna	9368

## 8.4 Specifications

406 MHz Transmitter	
<b>Frequency</b>	406 MHz
<b>Output Power</b>	5 Watts
<b>Digital Message Format</b>	RLB-33: Standard Location Protocol <sup>2</sup> RLB-32: Standard Location Protocol <sup>1</sup>
<b>Duration</b>	RLB-33: 520 ms RLB-32: 440 ms
<b>Frequency Stability</b>	±2 parts per billion/100ms
<b>Rate</b>	400 bps
<b>Modulation</b>	±1.1 radians peak
<b>Encoding</b>	Biphase L
<p><sup>1</sup> Leaves ACR with Serialized U.S. code but can be reprogrammed at a service center to Maritime or other coded format including nationality of registration.</p> <p><sup>2</sup> Leaves ACR with Serialized U.S. code but can be reprogrammed at a service center to Maritime MMSI.</p>	
Battery Life	
<b>Operating</b>	48 hours minimum
<b>Replacement Interval</b>	5 years or after use in an emergency
<b>Operating Temp Range</b>	CLASS 1 -40°C to +55°C CLASS 2 -20°C to +55°C
<b>Storage Temp Range</b>	CLASS 1 -50°C to +70°C CLASS 2 -40°C to +70°C
Xenon Strobe	
<b>Light Color</b>	White
<b>Output Power</b>	0.75 effective candela
<b>Flash Rate</b>	20-30 per minute

121.5 MHz Transmitter	
<b>Frequency</b>	121.5 MHz
<b>Frequency Tolerance</b>	±50 ppm
<b>Output Power</b>	50-100 mW PEP
<b>Modulation Type</b>	AM (3K20A3X)
<b>Sweep Range</b>	400 to 1200 Hz
<b>Sweep Rate</b>	3 Hz
<b>Duty Cycle</b>	37.5%
General/Environmental	
<b>Size (without antenna)</b>	7.2 x 4.3 x 3.7 in. (18.4 x 10.9 x 9.3 cm)
<b>Antenna Height</b>	7.39" (18.77 cm)
<b>EPIRB Material</b>	High impact UV resistant plastic
<b>Color</b>	High Vis Yellow
<b>Weight</b>	1.9 lbs. (861g)
<b>Waterproof</b>	Exceeds RTCM Standards - Factory Tested to 33 ft/10 m at room temperature
Antenna	
<b>Frequency</b>	406 & 121.5 MHz
<b>Polarization</b>	Vertical
<b>VSWR</b>	Less than 1.5/1

**ACR Electronics, Inc.**  
5757 Ravenswood Road, Ft. Lauderdale, FL 33312-6645  
Tel: +1 (954) 981 3333 Fax: +1 (954) 983-5087  
[www.acrelectronics.com](http://www.acrelectronics.com)



**European Office**  
1 Rose Cottages, Pitmore Lane, Sway,  
Lymington, Hampshire SO41 6BX UK  
Tel: +44-1590-682282 Fax: +44-1590-683828  
Email: [acr.europe@dial.pipex.com](mailto:acr.europe@dial.pipex.com)

## **MARINE EQUIPMENT DIRECTIVE** **DECLARATION OF CONFORMITY**

We hereby declare that the following product is in conformity with the Council Directive 96/98/EC of 20 December 1996 on Marine Equipment as amended by Commission Directive 2002/75/EC of 2 September 2002 and that it has been type examined as follows.

**Product:** 406 MHz (COSPAS-SARSAT) Emergency Position Indicating Radio Beacon (EPIRB) ACR RapidFix™ 406 RLB-33 (Cat. 1 & Cat. 2)

**Notified Body:** Bundesamt für Seeschifffahrt und Hydrographie (BSH) – Germany  
Notified Body No. 0735  
Certificate No.6492/050564-2/2004

**Type Examination:  
Standards** Annex A.1, Item No. A.1/5.6 and Annex B, Module B in the Directive  
IMO Res. A.810(19)  
IMO MSC.56(66), MSC.120(74)  
IMO MSC/Circ.862  
IMO Res. A.694(17)  
IEC 61097-2  
IEC 60945  
ETS 300 066  
COSPAS-SARSAT C/S T.001  
COSPAS-SARSAT C/S T.007

**Manufacturer:** ACR Electronics Inc. Fort Lauderdale, Florida, USA

**EU Representative:** ACR Electronics Inc. (European Office)  
Lymington, Hampshire UK.

**Signed on behalf of ACR Electronics Inc.**

Signed : 

**Name:** John F. Flood  
**Date :** April 11, 2006

**Title:** V.P. Engineering



**European Office**

1 Rose Cottages, Pitmore Lane, Sway,  
Lymington, Hampshire SO41 6BX UK  
Tel: +44-1590-682282 Fax: +44-1590-683828  
Email: [acr.europe@dial.pipex.com](mailto:acr.europe@dial.pipex.com)

## **MARINE EQUIPMENT DIRECTIVE** **DECLARATION OF CONFORMITY**

We hereby declare that the following product is in conformity with the Council Directive 96/98/EC of 20 December 1996 on Marine Equipment as amended by Commission Directive 2002/75/EC of 2 September 2002 and that it has been type examined as follows.

**Product:** 406 MHz (COSPAS-SARSAT) Emergency Position Indicating Radio Beacon (EPIRB)  
ACR Satellite<sub>2</sub> 406™ RLB-32 (Cat. 1 & Cat. 2)

**Notified Body:** Bundesamt für Seeschifffahrt und Hydrographie (BSH) – Germany Notified Body No. 0735  
Certificate No.6492/050564-1/2004

**Type Examination:  
Standards** Annex A.1, Item No. A.1/5.6 and Annex B, Module B in the Directive  
IMO Res. A.810(19)  
IMO MSC.56(66), MSC.120(74)  
IMO MSC/Circ.862  
IMO Res. A.694(17)  
IEC 61097-2  
IEC 60945  
ETS 300 066  
COSPAS-SARSAT C/S T.001  
COSPAS-SARSAT C/S T.007

**Manufacturer:** ACR Electronics Inc. Fort Lauderdale, Florida, USA

**EU Representative:** ACR Electronics Inc. (European Office)  
Lymington, Hampshire, UK.

Signed on behalf of ACR Electronics Inc.

Signed : \_\_\_\_\_

Name: John F. Flood  
Date: April 11, 2006

Title: V.P. Engineering



**European Office**  
1 Rose Cottages, Pitmore Lane, Sway,  
Lymington, Hampshire SO41 6BX UK  
Tel: +44-1590-682282 Fax: +44-1590-683828  
Email: [acr.europe@dial.pipex.com](mailto:acr.europe@dial.pipex.com)

## **INTERNATIONAL MARITIME ORGANIZATION** **SHORE BASED MAINTENANCE**

The Maritime Safety Committee approved guidelines for shore-based maintenance (SBM) of satellite EPIRBs, for the purpose of establishing standardized procedures and minimum levels of service for the testing and maintenance of satellite EPIRBs to ensure maximum reliability whilst minimizing the risk of false distress alerts.

Ref. T2/6.01  
MSC/Circ.1039

**Products:** 406 MHz (COSPAS-SARSAT) Emergency Position-Indicating Radio Beacons (EPIRBs):

- ACR Satellite 406™ RLB-27/28 (Cat. 1 & Cat. 2)
- ACR Satellite<sub>2</sub> 406™ RLB-32 (Cat. 1 & Cat. 2)
- ACR RapidFix™ RLB-33 (Cat. 1 & Cat. 2)
- ACR GlobalFix™ RLB-35 (Cat. 1 & Cat. 2)
- ACR Float Free 406 Memory Capsule RLB-35MC (Cat. 1)

**Maintenance Service Interval:** 406 MHz satellite EPIRBs should be inspected and tested annually in accordance with MSC/Circ.1040. Shore-based maintenance of all satellite EPIRBs should be carried out by the flag administration and not exceeding 5 years. It is recommended that maintenance be performed at the time when the battery is to be changed.

All ACR 406 MHz EPIRBs shall have their first shore-based maintenance performed on the same dates as their battery replacement.

**SBM Providers:** ACR only authorizes battery replacements and shore based maintenance to be performed by certified ACR service providers.

**Manufacturer:** ACR Electronics Inc., Fort Lauderdale, Florida USA

Signed on behalf of ACR Electronics Inc.

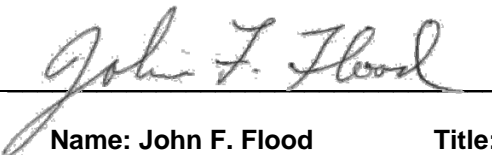
Signed : 

**Name: John F. Flood**

**Title: V.P. Engineering**

**Date: September 27, 2006**



# ACR ELECTRONICS INC.

## PRODUCT INFORMATION FOR PEOPLE’S REPUBLIC OF CHINA

### NOTE TO USERS OF GlobalFix™, RapidFix™, or Satellite<sub>2</sub> 406™, NAT GPIRB, SATFIND 406, GEOTRACK 406

**Table 1**

Component Name	Toxic or Hazardous Substances or Elements					
	Lead (Pb)	Mercury (Hg)	Cadmium (Cd)	Hexavalent Chromium (Cr6+)	Polybrominated Biphenyls (PBB)	Polybrominated Diphenyl Ethers (PBDE)
Printed circuit assembly	X	O	O	O	O	O
Battery pack assembly	X	O	O	O	O	O
<p>O: Indicates that the toxic or hazardous substance contained in all of the homogeneous materials for this component is below the limit requirement in SJ/T11363–2006</p> <p>X: Indicates that the toxic or hazardous substance contained in at least one of the homogeneous materials used for this component is above the limit requirement in SJ/T11363–2006</p> <p>Assemblies include population of components, solder and interconnects.</p>						

### Product Marking Explanations

In accordance with the requirements specified in SJ/T11364–2006, all ACR EIPs sold in the People’s Republic of China are marked with a pollution control marking. The following marking applies to ACR products.



This marking indicates that some homogeneous substance within the EIP contains toxic or hazardous substances or elements above the requirements listed in SJ/T11363–2006. These substances are identified in Table 1.

### Environmentally Friendly Use Period

The number in the marking, shown as 20 in the illustration above, refers to the EIP’s Environmentally Friendly Use Period (EFUP). The EFUP is the number of years from the date of manufacture that toxic or hazardous substances or elements contained in EIPs will not leak or mutate under the normal operating conditions described in the EIP user documentation, resulting in any environmental pollution, bodily injury, or damage to assets.

**Note** Except as expressly stated herein and as required under mandatory provisions of regulations of the People’s Republic of China, ACR Electronics Inc. makes no representation or warranty of any kind, expressed or implied, with respect to the EFUP and expressly disclaims any representations or warranties, expressed or implied, with respect to the EFUP.



ACR ELECTRONICS INC.

# 中华人民共和国产品信息

**GlobalFix™ RLB-35, RapidFix™ RLB-33, or Satellite<sub>2</sub> 406™ RLB-32,  
NAT GPIRB, SATFIND 406, GEOTRACK 406 用户须知**

表 1

部件名称	有毒有害物质或元素					
	铅 (Pb)	汞 (Hg)	镉 (Cd)	六价铬 (Cr6+)	多溴联苯 (PBB)	多溴二苯醚 (PBDE)
印刷电路板组件	X	○	○	○	○	○
电池组件	X	○	○	○	○	○
O: 表示该有毒有害物质在该部件所有均质材料中的含量均在SJ/T11363-2006 标准规定的限量要求以下。						
X: 表示该有毒有害物质至少在该部件的某一均质材料中的含量超出SJ/T11363-2006 标准规定的限量要求。						
组件包含元器件,焊接材料和连接件						

## 产品标识说明

根据SJ/T11364-2006 的要求，中华人民共和国境内销售的所有ACR 电子信息产品均注明污染控制标识。ACR 产品使用以下标识。



该标识表示该电子信息产品某一均质材料中有毒、有害物质或元素的含量超出SJ/T11363-2006 规定的限量。相关物质见表1。

可能由于产品体积或功能等因素而未直接在产品上注明。但产品仍符合SJ/T11364-2006 的要求，且其标识信息已在本文说明。

## 环保使用期限

标识中的数字（即上述图例中的“20”）指电子信息产品环保使用期限 (EFUP)。电子信息产品环保使用期限是指在正常使用的条件下，电子信息产品中含有的有毒、有害物质或元素不会发生外泄或突变并导致对环境造成严重污染或对人身、财产造成严重损害的期限。

注除根据中华人民共和国法规的强制性规定在此作出明示声明的以外，ACR Electronics Inc.

对电子信息产品环保使用期限不作任何形式的陈述或保证（无论是明示或默示），并且不对电子信息产品环保使用期限的任何陈述或保证（无论是明示或默示）承担任何责任。