

TECHNICAL & SERVICE MANUAL

Series PLH

Ceiling Cassettes R407C

Indoor unit [Model names]

PLH-P3AAH

PLH-P4AAH

PLH-P5AAH

PLH-P6AAH

[Service Ref.]

PLH-P3AAH.UK
PLH-P3AAH₁.UK
PLH-P4AAH.UK
PLH-P4AAH₁.UK
PLH-P5AAH.UK
PLH-P5AAH₁.UK
PLH-P6AAH.UK
PLH-P6AAH₁.UK

- PLH-P3AAH₁.UK, PLH-P4AAH₁.UK, PLH-P5AAH₁.UK and PLH-P6AAH₁ are added in REVISED EDITION-A. Outdoor units PUH-P3,4VGAA.UK and PUH-P3,4,5,6YGAA.UK which are connected to those indoor units are also added in it.
- Please void OC236.
- Refer to the OCT03 REVISED EDITION-C as for control relation. This manual does not cover outdoor units. When serving them, please refer to the service manual No.OC180REVISED EDITION-A, OC261 and this manual in a set.

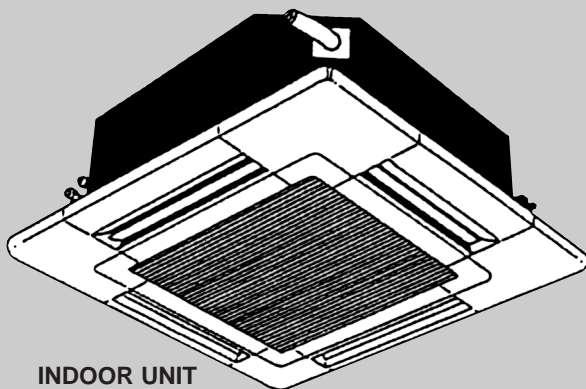

PLH-P*AAH.UK PLH-P*AAH₁.UK
WIRELESS REMOTE
CONTROLLER

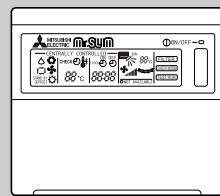
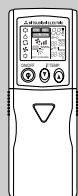

PLH-P*AAH.UK PLH-P*AAH₁.UK
WIRED REMOTE
CONTROLLER

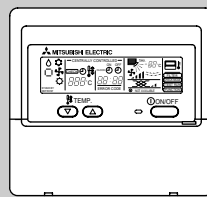

CONTENTS

1. TECHNICAL CHANGES	2
2. COMBINATION OF INDOOR AND OUTDOOR UNITS ..	2
3. SAFETY PRECAUTION	2
4. PART NAMES AND FUNCTIONS	4
5. SPECIFICATIONS	10
6. DATA	18
7. OUTLINES AND DIMENSIONS	43
8. WIRING DIAGRAM	44
9. REFRIGERANT SYSTEM DIAGRAM	45
10. TROUBLESHOOTING	47
11. DISASSEMBLY PROCEDURE	49
12. PARTS LIST	52
13. OPTIONAL PARTS	57

1

TECHNICAL CHANGES

PLH-P3AAH.UK → PLH-P3AAH₁.UK PLH-P4AAH.UK → PLH-P4AAH₁.UK

PLH-P5AAH.UK → PLH-P5AAH₁.UK PLH-P6AAH.UK → PLH-P6AAH₁.UK

- REMOTE CONTROLLER has changed.(PAR-S27A-E → PAR-20MAA-E, PAR-SL95A-E → PAR-SL97A-E)
- Outdoor units which are connected to PLH-P•AAH.UK and PLH-P•AAH₁.UK have been added.

2

COMBINATION OF INDOOR AND OUTDOOR UNITS

	Indoor unit	Outdoor unit										
		Heat pump type										
		PUH-P										
		3				4			5		6	
		VGA	YGA	VGAA.UK	YGAA.UK	YGA	VGAA.UK	YGAA.UK	YGA	YGAA.UK	YGA	YGAA.UK
Heat pump with electric heater	PLH-P3AAH.UK	○	○	○	○	—	—	—	—	—	—	—
	PLH-P3AAH ₁ .UK	—	—	○	○	—	—	—	—	—	—	—
	PLH-P4AAH.UK	—	—	—	—	○	○	○	—	—	—	—
	PLH-P4AAH ₁ .UK	—	—	—	—	—	○	○	—	—	—	—
	PLH-P5AAH.UK	—	—	—	—	—	—	—	○	○	—	—
	PLH-P5AAH ₁ .UK	—	—	—	—	—	—	—	—	○	—	—
	PLH-P6AAH.UK	—	—	—	—	—	—	—	—	—	○	○
	PLH-P6AAH ₁ .UK	—	—	—	—	—	—	—	—	—	—	○

3

SAFETY PRECAUTION

Cautions for devices that use R407C refrigerant.

- **Do not use the existing refrigerant piping.**
-The old refrigerant and lubricating oil in the existing piping contains a large amount of chlorine which may cause the lubricating oil of the new unit to deteriorate.
- **Use “low residual oil piping”.**
-If there is a large amount of residual oil (hydraulic oil, etc.) inside the piping and joints, deterioration of the lubricating oil will result.
- **Store the piping to be used during installation indoors and keep both ends of the piping sealed until just before brazing. (Store elbows and other joints in a plastic bag.)**
-If dust, dirt, or water enters the refrigerant cycle, deterioration of the oil and compressor trouble may result.
- **Use Suniso 4GS or 3GS (small amount) as the lubricating oil to coat flares and flange connection parts.**
-The lubricating oil used with the air conditioner is highly hygroscopic. If it is used, water may be mixed in and deterioration of the lubricating oil may result.
- **Use liquid refrigerant to charge the system.**
-If gas refrigerant is used to charge the system, the composition of the refrigerant in the cylinder will change and performance may drop.
- **Do not use a refrigerant other than R407C.**
-If another refrigerant (R22, etc.) is used, the chlorine in the refrigerant may cause the lubricating oil to deteriorate.
- **Use a vacuum pump with a reverse flow check valve.**
-The vacuum pump oil may flow back into the refrigerant cycle and cause the lubricating oil to deteriorate.

[1] Service tools

Use the below service tools as exclusive tools for R407C refrigerant.

No.	Tool name	Specifications
①	Gauge manifold	·Only for R407C.
		·Use the existing fitting SPECIFICATIONS. (UNF7/16)
		·Use high-tension side pressure of 35kgf/cm ² or over.
②	Charge hose	·Only for R407C.
		·Use pressure performance of 52kgf/cm ² or over.
③	Electronic scale	
④	Gas leak detector	·Use the detector for R134a or R407C.
⑤	Adapter for reverse flow check.	·Attach on vacuum pump.
⑥	Refrigerant charge base.	
⑦	Refrigerant cylinder.	·For R407C ·Top of cylinder (Brown)
		·Cylinder with syphon
⑧	Refrigerant recovery equipment.	

[2] Notice on repair service

- After recovering all the refrigerant in the unit, work may be started.
- Do not release the refrigerant in the air.
- After completing the repair service, recharge the system with the specified amount of the liquid refrigerant.

[3] Refrigerant recharging

- (1) Refrigerant recharging process
- Direct charging from the cylinder.
- Confirm that the cylinder is suitable for syphoning.
 - Raise the cylinder and recharge the unit by syphoning liquid refrigerant.

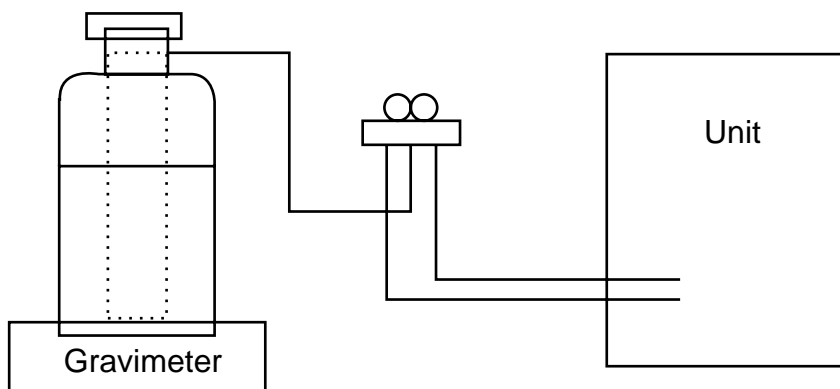

- (2) Recharge when refrigerant leakage has occurred.
- After recovering all the refrigerant in the unit, work may be started.
 - Do not release the refrigerant in the air.
 - After completing the repair service, recharge the system with the specified amount of the liquid refrigerant.

● Indoor (Main) Unit

PLH-P3AAH.UK, PLH-P4AAH.UK, PLH-P5AAH.UK, PLH-P6AAH.UK
 PLH-P3AAH₁.UK, PLH-P4AAH₁.UK, PLH-P5AAH₁.UK, PLH-P6AAH₁.UK

Horizontal Air Outlet

Sets airflow of horizontal automatically during cooling or dehumidifying.

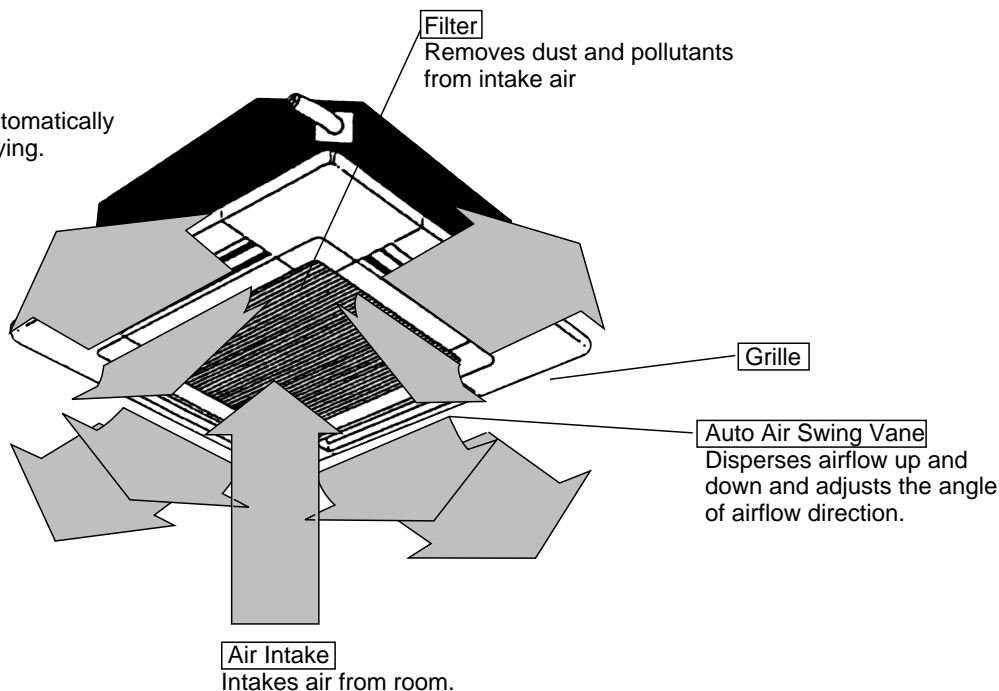

● Wired remote controller

On the controls are set, the same operation mode can be repeated by simply pressing the ON/OFF button.

PLH-P3AAH.UK, PLH-P4AAH.UK, PLH-P5AAH.UK, PLH-P6AAH.UK

● Operation buttons [PAR-S27A-E]

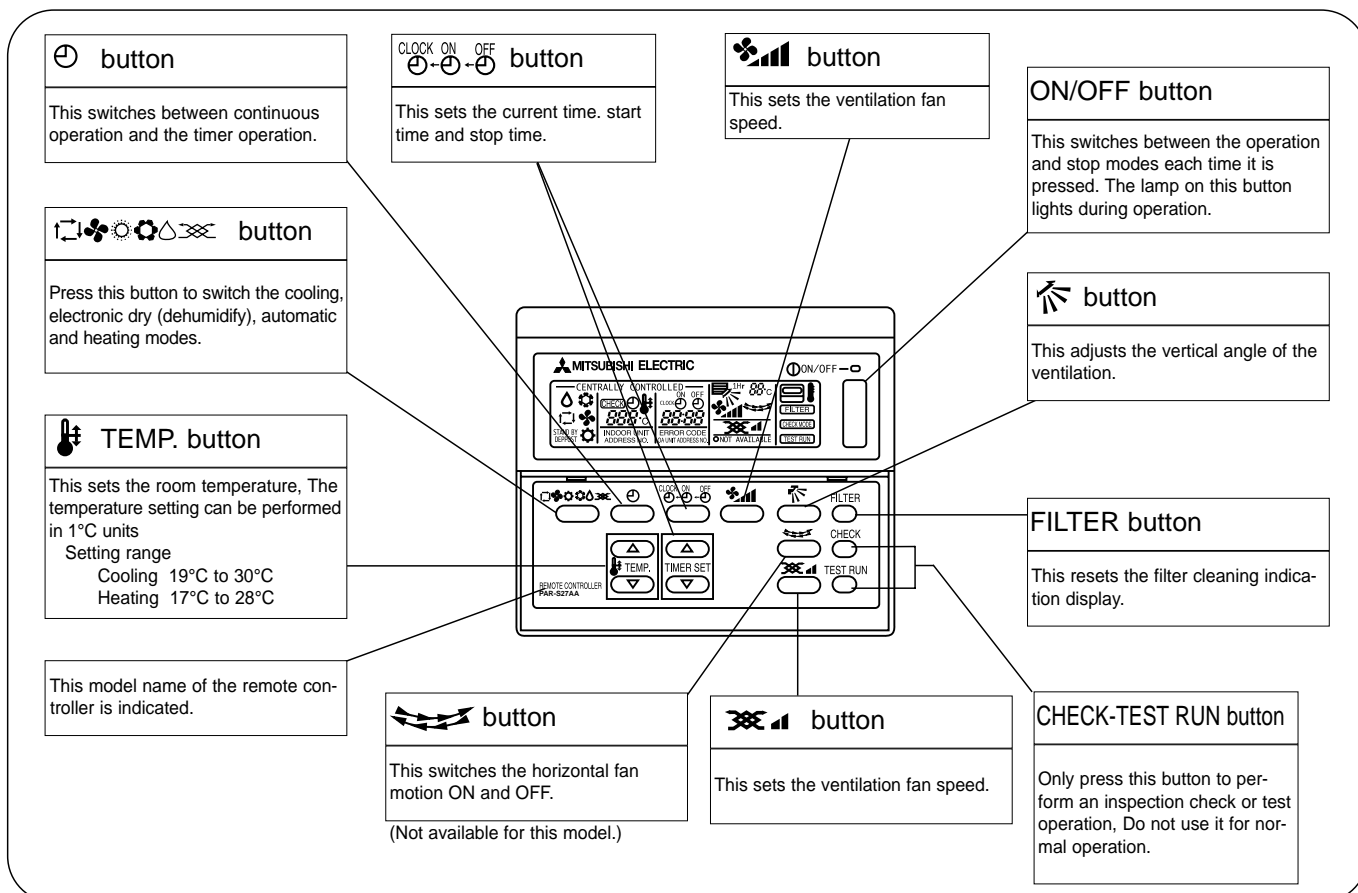

● Display

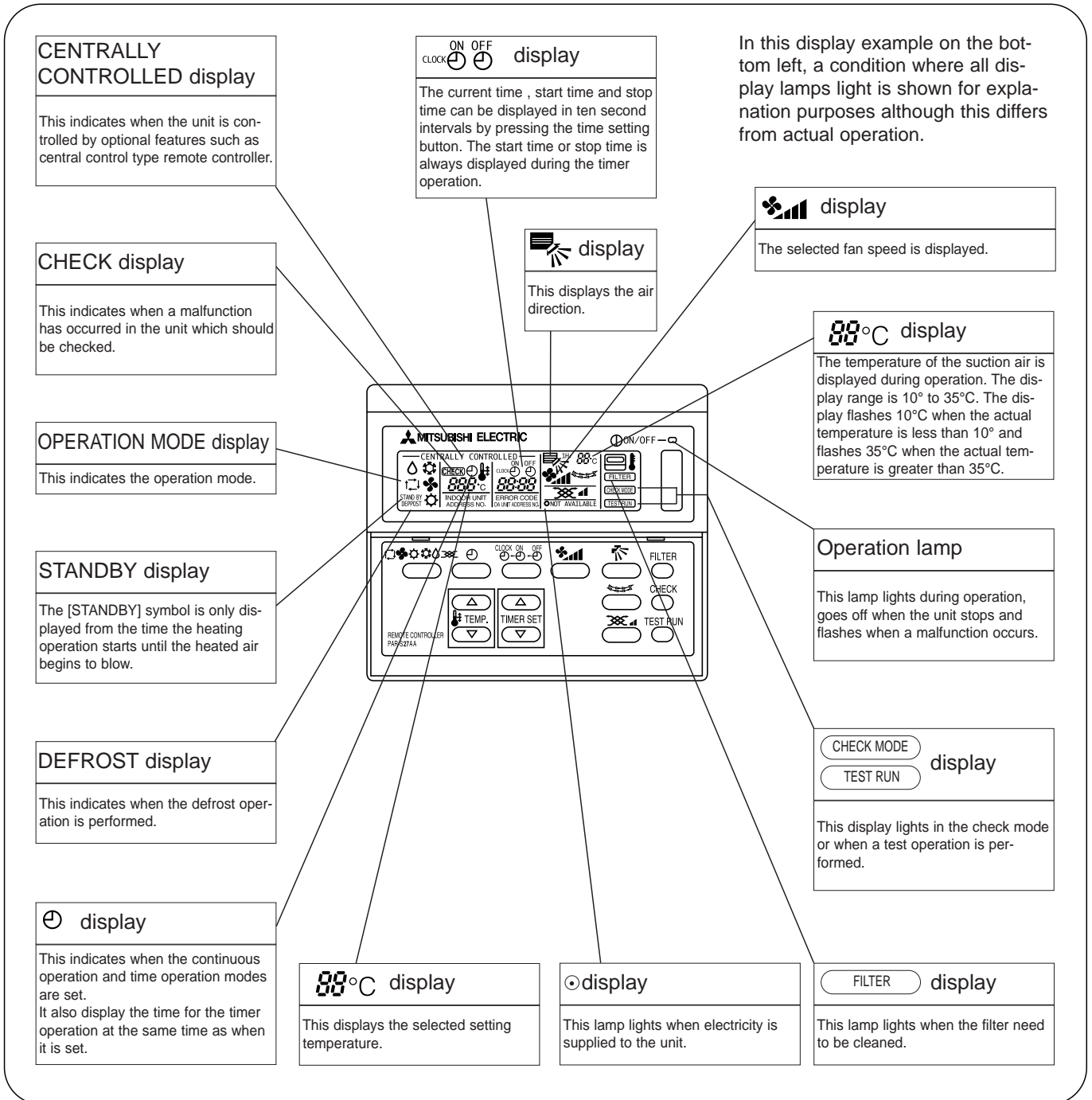

Caution

- Only the ⊙ display lights when the unit is stopped and power supplied to the unit.
- When power is turned ON for the first time the (CENTRAL CTRL) display appears to go off momentarily but this is not a malfunction.
- When the central control remote control unit, which is sold separately, is used the ON-OFF button, button and TEMP. button do not operate.
 - “NOT AVAILABLE” is displayed when the button are pressed. This indicates that this room unit is not equipped with the fan direction adjustment function and the louver function.
- When power is turned ON for the first time , it is normal that “HO” is displayed on the room temperature indication (For max. 2minutes).
Please wait until this “HO” indication disappears than start the operation.

PLH-P3AAH1.UK, PLH-P4AAH1.UK, PLH-P5AAH1.UK, PLH-P6AAH1.UK

● Operation buttons [PAR-20MAA-E]

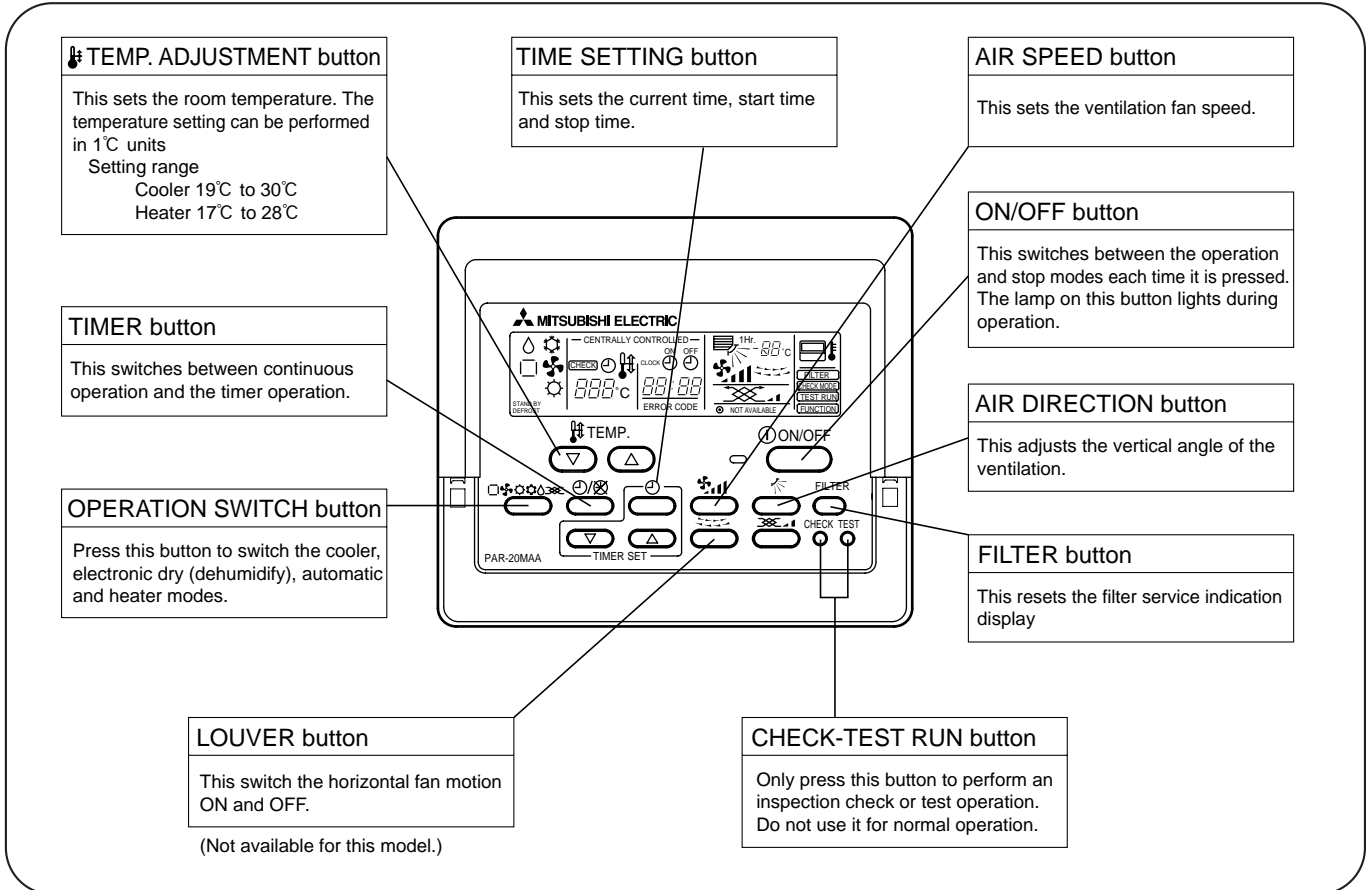

● Display

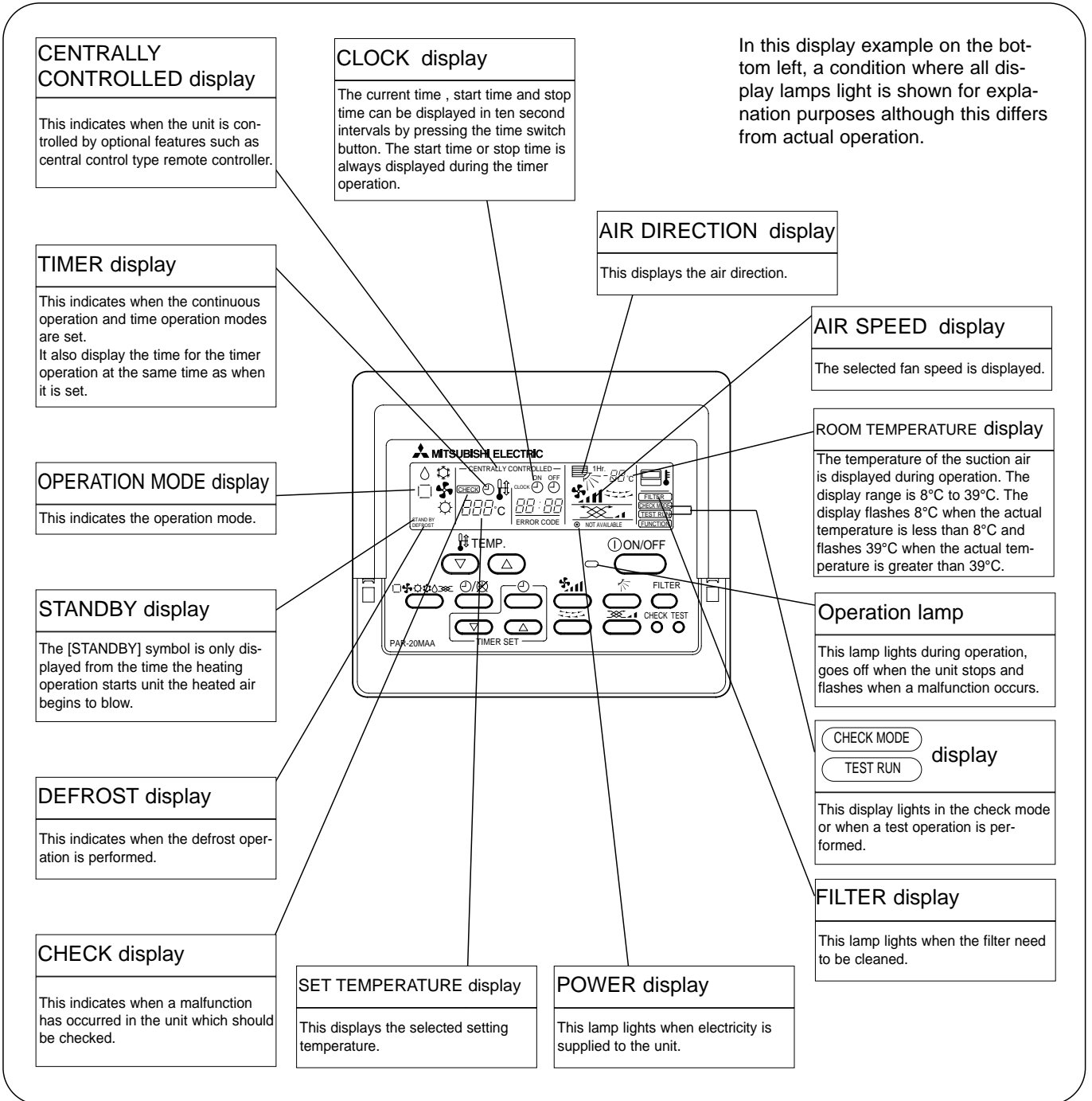







Caution

- Only the Power display lights when the unit is stopped and power supplied to the unit.
- When the central control remote control unit, which is sold separately, is used the ON-OFF button, operation switch button and TEMP. adjustment button do not operate.
- “NOT AVAILABLE” is displayed when the Air speed button are pressed. This indicates that this room unit is not equipped with the fan direction adjustment function and the louver function.
- When power is turned ON for the first time, it is normal that “H0” is displayed on the room temperature indication (For max. 2minutes). Please wait until this “H0” indication disappear then start the operation.



● **Wireless remote controller**

PLH-P3AAH.UK, PLH-P4AAH.UK, PLH-P5AAH.UK, PLH-P6AAH.UK

● When cover is open. [PAR-SL95A-E]

 display
Lights up while transmission to the indoor unit is mode using switches.
 display
OPERATION MODE display Operation mode display indicates which operation mode is in effect.
• FUNCTION display
Lights up when function are set.
• TEST RUN • CHECK display
CHECK&TEST RUN display indicates that the unit is being checked or test-run.
 display
Displays when batteries are dead.
 display
The vertical direction of airflow is indicated.
 display
FAN SPEED display indicates which fan speed has been selected.
 display
The unit is turned ON and OFF alternately each time the button is pressed.

ADDRESS display
Displays the refrigerant address.
UNIT NO. display
Displays the number of unit..
FUNCTION NO. display
Displays the mode.
SELECTION NO. display
Displays the selection number..

 display
SET TEMP. display indicates desired temperature set.
CLOCK display
Displays the current time.
"⊖" display
Flashes when the current time is displayed.
TIMER display
Displays when in timer operation or when setting timer.
"↑" "↓" display
Displays the order of timer operation.
"⊖- " "⊖-○" display
Displays whether timer is on or off.
"▼" "▲" display
Displays when the current time and the timer time can be changed.
 TEMP. button
SET TEMPERATURE button sets any desired room temperature.

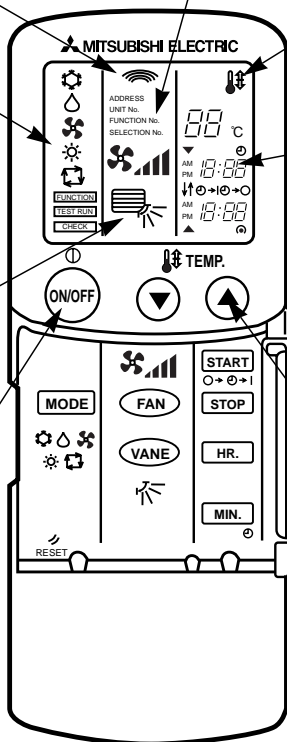

● When cover is open.

MODE SELECT button
Used to switch the operation mode between cooling , drying , blowing , heating and auto mode.
FAN SPEED SELECT button
Used to change the fan speed.
VANE CONTROL button
Used to change the airflow direction.

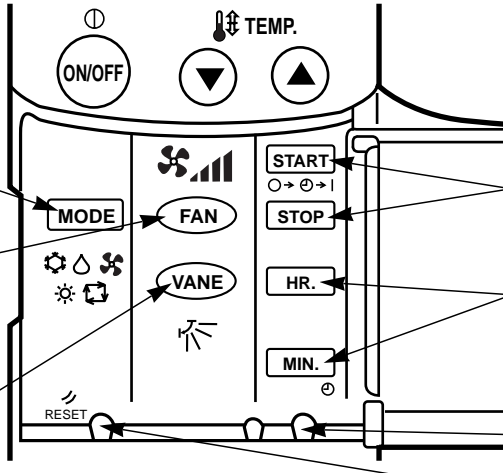

TIMER CONTROL buttons
STOP (OFF timer): when this switch is set, the air conditioner will be automatically stopped at the preset time. START (ON timer): when this switch is set, the air conditioner will be automatically started at the preset time.
HR. and MIN. buttons
Buttons used to set the "hour and minute" of the current time and timer settings.
⊖ button
RESET button

PLH-P3AAH1.UK, PLH-P4AAH1.UK, PLH-P5AAH1.UK, PLH-P6AAH1.UK

● When cover is open. [PAR-SL97A-E]

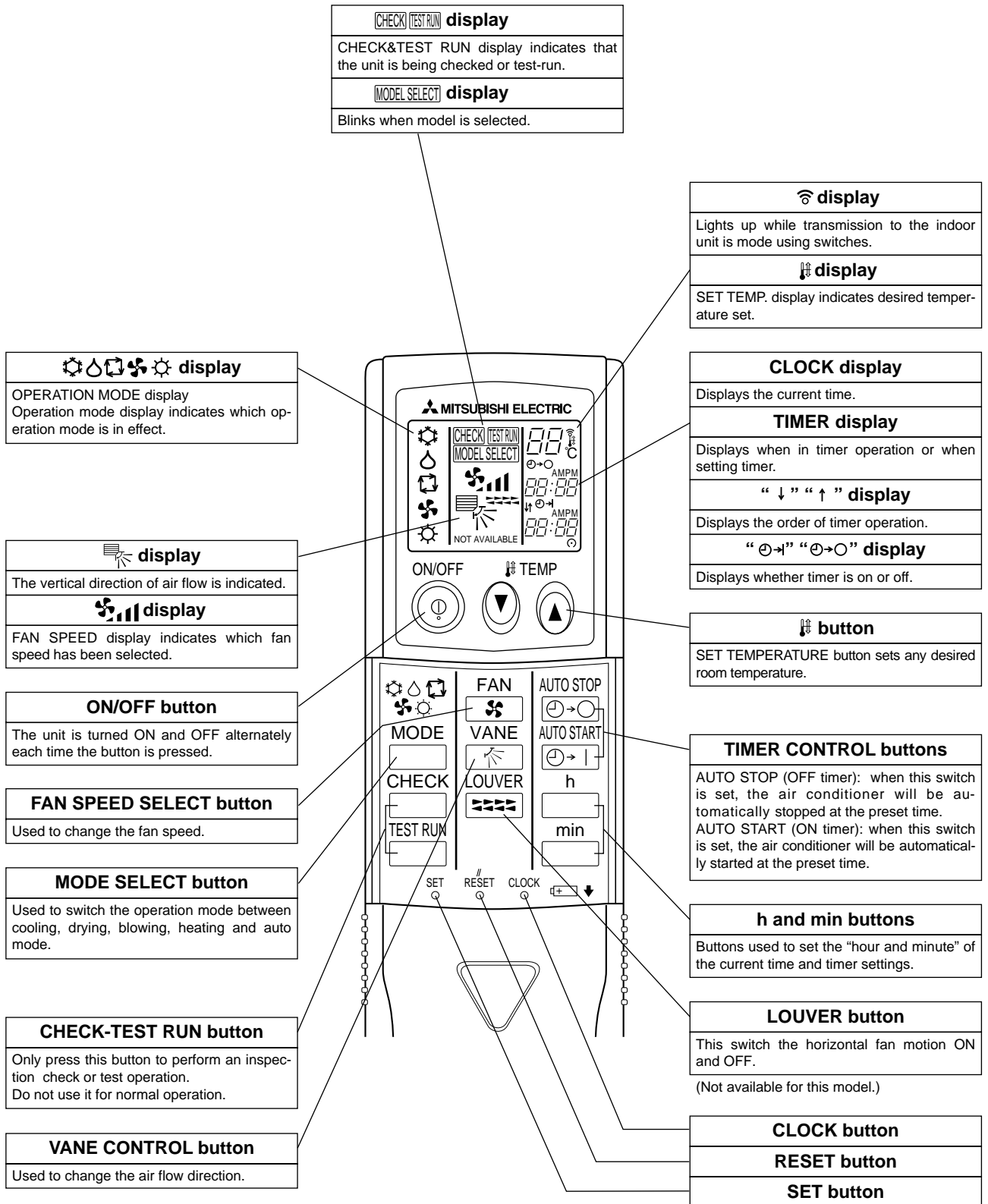

Item			Service Ref.	PLH-P3AAH.UK		
Function				Cooling	Heating	
Capacity	※1		Btu/h	26,600	31,700 [38,900]	
			W	7,800	9,300 [11,400]	
Total input	※1		kW	3.51	3.65 [5.75]	
Indoor unit	Service Ref.			PLH-P3AAH.UK		
	Power supply (phase, cycle, voltage)			Single phase, 50Hz, 220-230-240V		
	Input	※2		kW	0.17	0.17 <2.10>
			Running current	A	0.81	0.81 <8.75>
			Starting current	A	1.0	1.0 <8.75>
	External finish			Munsell 0.70Y 8.59/0.97		
	Heat exchanger			Plate fin coil		
	Fan	Fan (drive) × No.		Turbo fan (direct) × 1		
		Fan motor output		0.070		
		Airflow (Lo-Mi2-Mi1-Hi)		15-16-18-20 (530-565-635-705)		
		External static pressure		0 (direct blow)		
	Booster heater			kW		
				<2.1>		
	Operation control & Thermostat			Remote controller & built-in		
	Sound level (Lo-Mi2-Mi1-Hi)			dB		
				28-30-32-34		
Unit drain pipe I.D.			mm (in.)			
			32 (1-1/4)			
Dimensions	W		mm (in.)	UNIT : 840 (33-1/16) PANEL : 950 (37-3/8)		
	D		mm (in.)	UNIT : 840 (33-1/16) PANEL : 950 (37-3/8)		
	H		mm (in.)	UNIT : 258 (10-1/2) PANEL : 30 (1-3/16)		
Weight			kg (lbs.)			
			UNIT : 26 (57) PANEL : 5 (11)			
Outdoor unit	Service Ref.			PUH-P3VGA / PUH-P3YGA		
	Power supply (phase, cycle, voltage)			Single phase, 50Hz, 220-230-240V / 3 phases, 50Hz, 380-400-415V (4wires)		
	Running current	※2		A	14.64/5.46	15.43/5.76
			Starting current	A	93/41	
			External finish			Munsell 5Y 8/1
	Refrigerant control			Linear expansion valve		
	Compressor			Hermetic		
	Model			NE52VNJM / NE52YDJM		
	Motor output			kW		
				2.5		
	Starter type			Line start		
	Protection devices			Internal thermostat, HP switch, Discharge thermo. / Thermal relay, Discharge thermo., HP switch, Anti-phase protector		
	Heat exchanger			Plate fin coil		
	Fan	Fan (drive) × No.		Propeller (direct) × 1		
		Fan motor output		kW		
				0.070		
Airflow			m ³ /min (CFM)			
			50 (1,770)			
Crankcase heater			W			
			38			
Defrost method			Reverse cycle			
Sound level	Cooling		dB	49		
	Heating		dB	51		
Dimensions	W		mm (in.)	900 (35-7/16)		
	D		mm (in.)	330+20 (13+3/4)		
	H		mm (in.)	855 (33-5/8)		
Weight			kg (lbs.)			
			82 (181)			
Refrigerant piping	Refrigerant			R407C		
	Charge			kg (lbs.)		
				3.7 (8.2)		
	Oil (Model)			L		
				1.6 (MEL56)		
	Pipe size O.D.	Liquid		mm (in.)	9.52 (3/8)	
		Gas		mm (in.)	15.88 (5/8)	
	Connection method			Indoor side		
			Outdoor side			
Between the indoor & outdoor units			Height difference			
			Piping length			
			Max. 50m			
			Max. 50m			

- NOTE:** 1. Rating conditions (ISO T1)
Cooling : Indoor : D.B. 27°C (80°F) W.B. 19°C (66°F) Outdoor : D.B. 35°C (95°F) W.B. 24°C (75°F)
Heating : Indoor : D.B. 20°C (68°F) Outdoor : D.B. 7°C (45°F) W.B. 6°C (43°F)
Refrigerant piping length (one way) : 5m (16ft.)

2. Guaranteed operating range

		Indoor	Outdoor
Cooling	Upper limit	D.B. 35°C, W.B. 22.5°C	D.B. 46°C
	Lower limit	D.B. 19°C, W.B. 15°C	D.B. -5°C
Heating	Upper limit	D.B. 28°C	D.B. 24°C, W.B. 18°C
	Lower limit	D.B. 17°C	D.B. -11°C, W.B. -12°C

※1 : [] Shows the total rating.

※2 : < > Shows the only booster heater rating.

3. Above data based on indicated voltage
Indoor unit Single phase 240V 50Hz
Outdoor unit Single phase 240V 50Hz / 3 phases 415V 50Hz

Service Ref.			PLH-P4AAH.UK		
Item					
Function			Cooling	Heating	
Capacity	*1	Btu/h	33,100	36,200 [45,000]	
		W	9,700	10,600 [13,200]	
Total input	*1	kW	3.62	3.80 [6.40]	
Indoor unit	Service Ref.		PLH-P4AAH.UK		
	Power supply (phase, cycle, voltage)		Single phase, 50Hz, 220-230-240V		
	Input	*2 kW	0.26	0.26 <2.60>	
	Running current	*2 A	1.25	1.25 <10.83>	
	Starting current	*2 A	2.0	2.0 <10.83>	
	External finish		Munsell 0.70Y 8.59/0.97		
	Heat exchanger		Plate fin coil		
	Fan	Fan (drive) × No.		Turbo fan (direct) × 1	
		Fan motor output		0.120	
		Airflow (Lo-Mi2-Mi1-Hi)		20-23-26-28 (705-810-920-990)	
		External static pressure		0 (direct blow)	
	Booster heater		kW		
			<2.6>		
	Operation control & Thermostat		Remote controller & built-in		
	Sound level (Lo-Mi2-Mi1-Hi)		dB		
			33-36-39-41		
Unit drain pipe I.D.		mm (in.)			
		32 (1-1/4)			
Dimensions	W	mm (in.)	UNIT : 840 (33-1/16) PANEL : 950 (37-3/8)		
	D	mm (in.)	UNIT : 840 (33-1/16) PANEL : 950 (37-3/8)		
	H	mm (in.)	UNIT : 298 (11-3/4) PANEL : 30 (1-3/16)		
Weight		kg (lbs.)	UNIT : 32 (71) PANEL : 5 (11)		
Outdoor unit	Service Ref.		PUH-P4YGA		
	Power supply (phase, cycle, voltage)		3 phases, 50Hz, 380-400-415V (4wires)		
	Running current	A	5.49	5.79	
	Starting current	A	45		
	External finish		Munsell 5Y 8/1		
	Refrigerant control		Linear expansion valve		
	Compressor		Hermetic		
	Model		NE56YDJM		
	Motor output		kW		
			2.7		
	Starter type		Line start		
	Protection devices		Anti-phase protector, Thermal relay, Discharge thermo., HPswitch		
	Heat exchanger		Plate fin coil		
	Fan	Fan (drive) × No.		Propeller (direct) × 2	
		Fan motor output		kW	
				0.070+0.070	
Airflow		m ³ / min (CFM)	85 (3,000)		
Crankcase heater		W	38		
Defrost method		Reverse cycle			
Sound level	Cooling	dB	51		
	Heating	dB	53		
Dimensions	W	mm (in.)	900 (35-7/16)		
	D	mm (in.)	330+20 (13+3/4)		
	H	mm (in.)	1,260 (49-5/8)		
Weight		kg (lbs.)	96 (212)		
Refrigerant piping	Refrigerant		R407C		
	Charge		kg (lbs.)		
			4.0 (8.8)		
	Oil (Model)		L		
			1.6 (MEL56)		
	Pipe size O.D.	Liquid	mm (in.)	9.52 (3/8)	
		Gas	mm (in.)	19.05 (3/4)	
Connection method	Indoor side		Flared		
	Outdoor side		Flared		
Between the indoor & outdoor units	Height difference		Max. 50m		
	Piping length		Max. 50m		

- NOTE:**
- Rating conditions (ISO T1)
Cooling : Indoor : D.B. 27°C (80°F), W.B. 19°C (66°F) Outdoor : D.B. 35°C (95°F) W.B. 24°C (75°F)
Heating : Indoor : D.B. 20°C (68°F) Outdoor : D.B. 7°C (45°F) W.B. 6°C (43°F)
Refrigerant piping length (one way) : 5m (16ft.)

- Guaranteed operating range

		Indoor	Outdoor
Cooling	Upper limit	D.B. 35°C , W.B. 22.5°C	D.B. 46°C
	Lower limit	D.B. 19 °C , W.B. 15°C	D.B. -5°C
Heating	Upper limit	D.B. 28°C	D.B. 24°C , W.B. 18°C
	Lower limit	D.B. 17°C	D.B. -11°C , W.B. -12°C

*1 : [] Shows the total rating.

*2 : < > Shows the only booster heater rating.

- Above data based on indicated voltage
Indoor unit Single phase 240V 50Hz
Outdoor unit 3 phases 415V 50Hz

Service Ref.			PLH-P5AAH.UK			
Item						
Function			Cooling	Heating		
Capacity	*1	Btu/h	43,700	54,600 [64,800]		
		W	12,800	16,000 [19,000]		
Total input	*1	kW	5.55	5.93 [8.93]		
Indoor unit	Service Ref.		PLH-P5AAH.UK			
	Power supply (phase, cycle, voltage)		Single phase, 50Hz, 220-230-240V			
	Input	*2	kW	0.30 <3.00>		
	Running current	*2	A	1.43 <12.50>		
	Starting current	*2	A	2.0 <12.50>		
	External finish		Munsell 0.70Y 8.59/0.97			
	Heat exchanger		Plate fin coil			
	Fan	Fan (drive) × No.		Turbo fan (direct) × 1		
		Fan motor output		0.120		
		Airflow (Lo-Mi2-Mi1-Hi)		22-25-28-30 (775-880-990-1,060)		
		External static pressure		0 (direct blow)		
	Booster heater		kW		<3.0>	
	Operation control & Thermostat		Remote controller & built-in			
	Sound level (Lo-Mi2-Mi1-Hi)		dB		35-38-41-43	
	Unit drain pipe I.D.		mm (in.)		32 (1-1/4)	
Dimensions	W	mm (in.)	UNIT : 840 (33-1/16) PANEL : 950 (37-3/8)			
	D	mm (in.)	UNIT : 840 (33-1/16) PANEL : 950 (37-3/8)			
	H	mm (in.)	UNIT : 298 (11-3/4) PANEL : 30 (1-3/16)			
Weight		kg (lbs.)		UNIT : 32 (71) PANEL : 5 (11)		
Outdoor unit	Service Ref.		PUH-P5YGA			
	Power supply (phase, cycle, voltage)		3 phases, 50Hz, 380-400-415V (4wires)			
	Running current	A	8.39	8.74		
	Starting current	A	79			
	External finish		Munsell 5Y 8/1			
	Refrigerant control		Linear expansion valve			
	Compressor		Hermetic			
	Model		HE86YAA			
	Motor output		kW		4.3	
	Starter type		Line start			
	Protection devices		Internal thermostat, Anti-phase protector, Thermal relay, HP switch, LP switch, Discharge thermo.			
	Heat exchanger		Plate fin coil			
	Fan	Fan (drive) × No.		Propeller (direct) × 2		
		Fan motor output		kW		0.075+0.075
		Airflow		m ³ / min (CFM)		95 (3,360)
Crankcase heater		W		38		
Defrost method		Reverse cycle				
Sound level	Cooling	dB	53			
	Heating	dB	55			
Dimensions	W	mm (in.)	1,050 (41-5/16)			
	D	mm (in.)	330+20 (13+3/4)			
	H	mm (in.)	1,260 (49-5/8)			
Weight		kg (lbs.)		122 (269)		
Refrigerant piping	Refrigerant		R407C			
	Charge		kg (lbs.)		5.8 (12.8)	
	Oil (Model)		L		2.0 (MEL32)	
	Pipe size O.D.	Liquid	mm (in.)	9.52 (3/8)		
		Gas	mm (in.)	19.05 (3/4)		
	Connection method	Indoor side		Flared		
		Outdoor side		Flared		
Between the indoor & outdoor units	Height difference		Max. 50m			
	Piping length		Max. 50m			

- NOTE:**
- Rating conditions (ISO T1)
Cooling : Indoor : D.B. 27°C (80°F), W.B. 19°C (66°F) Outdoor : D.B. 35°C (95°F) W.B. 24°C (75°F)
Heating : Indoor : D.B. 20°C (68°F) Outdoor : D.B. 7°C (45°F) W. B. 6°C (43°F)
Refrigerant piping length (one way) : 5m (16ft.)

- Guaranteed operating range

		Indoor	Outdoor
Cooling	Upper limit	D.B. 35°C, W.B. 22.5°C	D.B. 46°C
	Lower limit	D.B. 19°C, W.B. 15°C	D.B. -5°C
Heating	Upper limit	D.B. 28°C	D.B. 24°C, W.B. 18°C
	Lower limit	D.B. 17°C	D.B. -11°C, W.B. -12°C

- *1 : [] Shows the total rating.
*2 : <> Shows the only booster heater rating.

- Above data based on indicated voltage
Indoor unit Single phase 240V 50Hz
Outdoor unit 3 phases 415V 50Hz

Service Ref.			PLH-P6AAH.UK			
Item						
Function			Cooling	Heating		
Capacity	*1	Btu/h	48,000	57,300 [67,600]		
		W	14,300	16,800 [19,800]		
Total input	*1	kW	6.70	6.77 [9.77]		
Indoor unit	Service Ref.		PLH-P6AAH.UK			
	Power supply (phase, cycle, voltage)		Single phase, 50Hz, 220-230-240V (4wires)			
	Input	*2 kW	0.34	0.34 <3.00>		
	Running current	*2 A	1.64	1.64 <12.50>		
	Starting current	*2 A	2.0	2.0 <12.50>		
	External finish		Munsell 0.70Y 8.59/0.97			
	Heat exchanger		Plate fin coil			
	Fan	Fan (drive) × No.		Turbo fan (direct) × 1		
		Fan motor output		0.120		
		Airflow (Lo-Mi2-Mi1-Hi)		22-25-28-30 (775-880-990-1,060)		
		External static pressure		0 (direct blow)		
	Booster heater		kW		<3.0>	
	Operation control & Thermostat		Remote controller & built-in			
	Sound level (Lo-Mi2-Mi1-Hi)		dB		37-40-43-45	
	Unit drain pipe I.D.		mm (in.)		32 (1-1/4)	
	Dimensions	W	mm (in.)	UNIT : 840 (33-1/16) PANEL : 950 (37-3/8)		
D		mm (in.)	UNIT : 840 (33-1/16) PANEL : 950 (37-3/8)			
H		mm (in.)	UNIT : 298 (11-3/4) PANEL : 30 (1-3/16)			
Weight		kg (lbs.)		UNIT : 34 (75) PANEL : 5 (11)		
Outdoor unit	Service Ref.		PUH-P6YGA			
	Power supply (phase, cycle, voltage)		3 phases, 50Hz, 380-400-415V (4wires)			
	Running current	A	10.17	10.28		
	Starting current	A	84			
	External finish		Munsell 5Y 8/1			
	Refrigerant control		Linear expansion valve			
	Compressor		Hermetic			
	Model		HE101YAA			
	Motor output		kW		5.1	
	Starter type		Line start			
	Protection devices		Internal thermostat, Anit-phase protector, Thermal relay, HP switch, LP switch, Discharge thermo.			
	Heat exchanger		Plate fin coil			
	Fan	Fan (drive) × No.		Propeller (direct) × 2		
		Fan motor output		kW		0.075+0.075
		Airflow		m³ / min (CFM)		100 (3,530)
	Crankcase heater		W		38	
Defrost method		Reverse cycle				
Sound level	Cooling	dB	55			
	Heating	dB	57			
Dimensions	W	mm (in.)	1,050 (41-5/16)			
	D	mm (in.)	330+20(13+3/4)			
	H	mm (in.)	1,260 (49-5/8)			
Weight		kg (lbs.)		122 (269)		
Refrigerant piping	Refrigerant		R407C			
	Charge		kg (lbs.)		5.8 (12.8)	
	Oil (Model)		L		2.0 (MEL32)	
	Pipe size O.D.	Liquid	mm (in.)	9.52 (3/8)		
		Gas	mm (in.)	19.05 (3/4)		
	Connection method		Indoor side		Flared	
			Outdoor side		Flared	
	Between the indoor & outdoor units		Height difference		Max. 50m	
		Piping length		Max. 50m		

NOTE: 1. Rating conditions (ISO T1)
Cooling : Indoor : D.B. 27°C (80°F), W.B. 19°C (66°F) Outdoor : D.B. 35°C (95°F) W.B. 24°C (75°F)
Heating : Indoor : D.B. 20°C (68°F) Outdoor : D.B. 7°C (45°F) W.B. 6°C (43°F)
Refrigerant piping length (one way) : 5m (16ft.)

2. Guaranteed operating range

		Indoor		Outdoor	
Cooling	Upper limit	D.B. 35°C, W.B. 22.5°C		D.B. 46°C	
	Lower limit	D.B. 19°C, W.B. 15°C		D.B. -5°C	
Heating	Upper limit	D.B. 28°C		D.B. 24°C, W.B. 18°C	
	Lower limit	D.B. 17°C		D.B. -11°C, W.B. -12°C	

*1 : [] Shows the total rating.

*2 : < > Shows the only booster heater rating.

3. Above data based on indicated voltage
Indoor unit Single phase 240V 50Hz
Outdoor unit 3 phases 415V 50Hz

Item			Service Ref.	PLH-P3AAH.UK / PLH-P3AAH.UK			
Function				Cooling	Heating		
Capacity	*1		Btu/h	26,600	31,700 [38,900]		
			W	7,800	9,300 [11,400]		
Total input	*1		kW	3.44	3.50 [5.60]		
Indoor unit	Service Ref.			PLH-P3AAH.UK / PLH-P3AAH.UK			
	Power supply (phase, cycle, voltage)			Single phase, 50Hz, 220-230-240V			
	Input	*2		kW	0.17	0.17 <2.10>	
			Running current	*2	A	0.81	0.81 <8.75>
			Starting current	*2	A	1.0	1.0 <8.75>
	External finish			Munsell 0.70Y 8.59/0.97			
	Heat exchanger			Plate fin coil			
	Fan	Fan (drive) × No.		Turbo fan (direct) × 1			
		Fan motor output		kW			
		Airflow (Lo-Mi2-Mi1-Hi)		m ³ / min (CFM)			
		External static pressure		Pa (mmAq)			
	Booster heater			kW			
	Operation control & Thermostat			Remote controller & built-in			
	Sound level (Lo-Mi2-Mi1-Hi)			dB			
	Unit drain pipe I.D.			mm (in.)			
	Dimensions	W		mm (in.)	UNIT : 840 (33-1/16) PANEL : 950 (37-3/8)		
D			mm (in.)	UNIT : 840 (33-1/16) PANEL : 950 (37-3/8)			
H			mm (in.)	UNIT : 258 (10-1/2) PANEL : 30 (1-3/16)			
Weight			kg (lbs.)				
			UNIT : 26 (57) PANEL : 5 (11)				
Outdoor unit	Service Ref.			PUH-P3VGAA.UK / PUH-P3YGAA.UK			
	Power supply (phase, cycle, voltage)			Single phase, 50Hz, 220-230-240V / 3 phases, 50Hz, 380-400-415V (4wires)			
	Running current			A	14.81/ 5.29	15.76/ 5.63	
			Starting current	A	93/ 47		
			External finish			Munsell 5Y 7/1	
	Refrigerant control			Linear expansion valve			
	Compressor			Hermetic			
	Model			NE52VNJMT/ NE52YDJMT			
	Motor output			kW			
	Starter type			Line start			
	Protection devices			Internal thermostat, HP switch, Discharge thermo. / Thermal relay, HPswitch, Discharge thermo.			
	Heat exchanger			Plate fin coil			
	Fan	Fan (drive) × No.		Propeller (direct) × 1			
		Fan motor output		kW			
		Airflow		m ³ / min (CFM)			
	Crankcase heater			W			
Defrost method			Reverse cycle				
Sound level	Cooling		dB	49			
	Heating		dB	51			
Dimensions	W		mm (in.)	900 (35-7/16)			
	D		mm (in.)	330+20 (13+3/4)			
	H		mm (in.)	855 (33-5/8)			
Weight			kg (lbs.)				
			82 (181)				
Refrigerant piping	Refrigerant			R407C			
	Charge			kg (lbs.)			
	Oil (Model)			L			
				3.3 (7.3)			
	Pipe size O.D.	Liquid		mm (in.)	9.52 (3/8)		
		Gas		mm (in.)	15.88 (5/8)		
	Connection method	Indoor side		Flared			
		Outdoor side		Flared			
Between the indoor & outdoor units	Height difference		Max. 50m				
	Piping length		Max. 50m				

NOTE: 1. Rating conditions (ISO T1)
Cooling : Indoor : D.B. 27°C (80°F) W.B. 19°C (66°F) Outdoor : D.B. 35°C (95°F) W.B. 24°C (75°F)
Heating : Indoor : D.B. 20°C (68°F) Outdoor : D.B. 7°C (45°F) W.B. 6°C (43°F)
Refrigerant piping length (one way) : 5m (16ft.)

2. Guaranteed operating range

		Indoor	Outdoor
Cooling	Upper limit	D.B. 35°C, W.B. 22.5°C	D.B. 46°C
	Lower limit	D.B. 19°C, W.B. 15°C	D.B. -5°C
Heating	Upper limit	D.B. 28°C	D.B. 24°C, W.B. 18°C
	Lower limit	D.B. 17°C	D.B. -11°C, W.B. -12°C

*1 : [] Shows the total rating.

*2 : <> Shows the only booster heater rating.

3. Above data based on indicated voltage

Indoor unit Single phase 240V 50Hz

Outdoor unit Single phase 240V 50Hz / 3 phases 415V 50Hz

Item			Service Ref.	PLH-P4AAH.UK / PLH-P4AAH _i .UK		
Function				Cooling	Heating	
Capacity	*1		Btu/h	33,100	36,200 [43,300]	
			W	9,700	10,600 [12,700]	
Total input			*1	kW	3.69	
					3.93 [6.03]	
Indoor unit	Service Ref.			PLH-P4AAH.UK / PLH-P4AAH _i .UK		
	Power supply (phase, cycle, voltage)			Single phase, 50Hz, 220-230-240V		
	Input	*2		kW	0.26	0.26 <2.60>
			Running current	A	1.25	1.25 <10.83>
			Starting current	A	2.0	2.0 <10.83>
	External finish			Munsell 0.70Y 8.59/0.97		
	Heat exchanger			Plate fin coil		
	Fan	Fan (drive) × No.		Turbo fan (direct) × 1		
		Fan motor output		kW		
		Airflow (Lo-Mi2-Mi1-Hi)		m ³ / min (CFM)		
		External static pressure		Pa (mmAq)		
	Booster heater			kW		
	Operation control & Thermostat			Remote controller & built-in		
	Sound level (Lo-Mi2-Mi1-Hi)			dB		
	Unit drain pipe I.D.			mm (in.)		
Dimensions	W		mm (in.)	UNIT : 840 (33-1/16) PANEL : 950 (37-3/8)		
	D		mm (in.)	UNIT : 840 (33-1/16) PANEL : 950 (37-3/8)		
	H		mm (in.)	UNIT : 298 (11-3/4) PANEL : 30 (1-3/16)		
Weight			kg (lbs.)			
			UNIT : 32 (71) PANEL : 5 (11)			
Outdoor unit	Service Ref.			PUH-P4VGAH.UK / PUH-P4YGAA.UK		
	Power supply (phase, cycle, voltage)			Single phase, 50Hz, 220-230-240V/ 3 phases, 50Hz, 380-400-415V (4wires)		
	Running current			A	15.71/ 5.55	16.58/ 5.86
			Starting current	A	99/ 49	
			External finish			Munsell 5Y 7/1
	Refrigerant control			Linear expansion valve		
	Compressor			Hermetic		
	Model			NE56VNJMT/ NE56YDKMT		
		Motor output		kW		
		Starter type		Line start		
		Protection devices		Internal thermostat, HP switch, Discharge thermo./ Thermal relay, HP switch, Discharge thermo.		
	Heat exchanger			Plate fin coil		
	Fan	Fan (drive) × No.		Propeller (direct) × 2		
		Fan motor output		kW		
		Airflow		m ³ / min (CFM)		
Crankcase heater			W			
Defrost method			Reverse cycle			
Sound level	Cooling		dB	51		
	Heating		dB	53		
Dimensions	W		mm (in.)	900 (35-7/16)		
	D		mm (in.)	330+20 (13+3/4)		
	H		mm (in.)	1,260 (49-5/8)		
Weight			kg (lbs.)			
			96 (212)			
Refrigerant piping	Refrigerant			R407C		
	Charge			kg (lbs.)		
		Oil (Model)		L		
	Pipe size O.D.	Liquid		mm (in.)	9.52 (3/8)	
		Gas		mm (in.)	19.05 (3/4)	
Connection method			Indoor side			
			Outdoor side			
Between the indoor & outdoor units			Height difference			
			Piping length			
			Max. 50m			
			Max. 50m			

NOTE: 1. Rating conditions (ISO T1)
Cooling : Indoor : D.B. 27°C (80°F), W.B. 19°C (66°F) Outdoor : D.B. 35°C (95°F) W.B. 24°C (75°F)
Heating : Indoor : D.B. 20°C (68°F) Outdoor : D.B. 7°C (45°F) W.B. 6°C (43°F)
Refrigerant piping length (one way) : 5m (16ft.)

2. Guaranteed operating range

		Indoor		Outdoor	
Cooling	Upper limit	D.B. 35°C	W.B. 22.5°C	D.B. 46°C	
	Lower limit	D.B. 19 °C	W.B. 15°C	D.B. -5°C	
Heating	Upper limit	D.B. 28°C		D.B. 24°C	W.B. 18°C
	Lower limit	D.B. 17°C		D.B. -11°C	W.B. -12°C

*1 : [] Shows the total rating.

*2 : < > Shows the only booster heater rating.

3. Above data based on indicated voltage

Indoor unit Single phase 240V 50Hz

Outdoor unit Single phase 240V 50Hz/ 3 phases 415V 50Hz

Service Ref.			PLH-P5AAH.UK / PLH-P5AAH1.UK		
Item					
Function			Cooling	Heating	
Capacity	※1	Btu/h	43,700	50,800 [61,100]	
		W	12,800	14,900 [17,900]	
Total input	※1	kW	5.00	5.34 [8.34]	
Indoor unit	Service Ref.		PLH-P5AAH.UK / PLH-P5AAH1.UK		
	Power supply (phase, cycle, voltage)		Single phase, 50Hz, 220-230-240V		
	Input	※2	kW	0.30	0.30 <3.00>
		Running current	※2	A	1.43 <12.50>
		Starting current	※2	A	2.0 <12.50>
	External finish		Munsell 0.70Y 8.59/0.97		
	Heat exchanger		Plate fin coil		
	Fan	Fan (drive) × No.		Turbo fan (direct) × 1	
		Fan motor output		0.120	
		Airflow (Lo-Mi2-Mi1-Hi)		m ³ / min (CFM)	
		External static pressure		Pa (mmAq)	
	Booster heater		kW		
	Operation control & Thermostat		Remote controller & built-in		
	Sound level (Lo-Mi2-Mi1-Hi)		dB		
	Unit drain pipe I.D.		mm (in.)		
Dimensions	W	mm (in.)	UNIT : 840 (33-1/16) PANEL : 950 (37-3/8)		
	D	mm (in.)	UNIT : 840 (33-1/16) PANEL : 950 (37-3/8)		
	H	mm (in.)	UNIT : 298 (11-3/4) PANEL : 30 (1-3/16)		
Weight		kg (lbs.)	UNIT : 32 (71) PANEL : 5 (11)		
Outdoor unit	Service Ref.		PUH-P5YGAA.UK		
	Power supply (phase, cycle, voltage)		3 phases, 50Hz, 380-400-415V (4wires)		
	Running current		A	7.60	8.15
		Starting current	A	65.5	
		External finish		Munsell 5Y 7/1	
	Refrigerant control		Linear expansion valve		
	Compressor		Hermetic		
	Model		ZR61KCE-TFD		
	Motor output		kW		
	Starter type		Line start		
	Protection devices		Internal thermostat, Thermal relay, HPswitch, Discharge thermo.		
	Heat exchanger		Plate fin coil		
	Fan	Fan (drive) × No.		Propeller (direct) × 2	
		Fan motor output		kW	
		Airflow		m ³ / min (CFM)	
Crankcase heater		W	38		
Defrost method		Reverse cycle			
Sound level	Cooling	dB	55		
	Heating	dB	56		
Dimensions	W	mm (in.)	1,050 (41-5/16)		
	D	mm (in.)	330+20 (13+3/4)		
	H	mm (in.)	1,260 (49-5/8)		
Weight		kg (lbs.)	122 (269)		
Refrigerant piping	Refrigerant		R407C		
	Charge		kg (lbs.)		
	Oil (Model)		L		
	Pipe size O.D.	Liquid	mm (in.)	9.52 (3/8)	
		Gas	mm (in.)	19.05 (3/4)	
	Connection method	Indoor side		Flared	
		Outdoor side		Flared	
Between the indoor & outdoor units	Height difference		Max. 50m		
	Piping length		Max. 50m		

NOTE: 1. Rating conditions (ISO T1)
Cooling : Indoor : D.B. 27°C (80°F), W.B. 19°C (66°F) Outdoor : D.B. 35°C (95°F) W.B. 24°C (75°F)
Heating : Indoor : D.B. 20°C (68°F) Outdoor : D.B. 7°C (45°F) W.B. 6°C (43°F)
Refrigerant piping length (one way) : 5m (16ft.)

2. Guaranteed operating range

		Indoor	Outdoor
Cooling	Upper limit	D.B. 35°C, W.B. 22.5°C	D.B. 46°C
	Lower limit	D.B. 19°C, W.B. 15°C	D.B. -5°C
Heating	Upper limit	D.B. 28°C	D.B. 24°C, W.B. 18°C
	Lower limit	D.B. 17°C	D.B. -11°C, W.B. -12°C

※1 : [] Shows the total rating.

※2 : < > Shows the only booster heater rating.

3. Above data based on indicated voltage
Indoor unit Single phase 240V 50Hz
Outdoor unit 3 phases 415V 50Hz

Service Ref.			PLH-P6AAH.UK / PLH-P6AAH1.UK	
Function			Cooling	Heating
Capacity	※1	Btu/h	48,000	58,300 [68,600]
		W	14,300	17,100 [20,100]
Total input	※1	kW	5.94	6.36 [9.36]
Service Ref.			PLH-P6AAH.UK / PLH-P6AAH1.UK	
Power supply (phase, cycle, voltage)			Single phase, 50Hz, 220-230-240V	
Input	※2	kW	0.34	0.34 <3.00>
		A	1.64	1.64 <12.50>
		A	2.0	2.0 <12.50>
External finish			Munsell 0.70Y 8.59/0.97	
Heat exchanger			Plate fin coil	
Fan	Fan (drive) × No.		Turbo fan (direct) × 1	
	Fan motor output		0.120	
	Airflow (Lo-Mi2-Mi1-Hi)		22-25-28-30 (775-880-990-1,060)	
	External static pressure		0 (direct blow)	
Booster heater			kW	
Operation control & Thermostat			Remote controller & built-in	
Sound level (Lo-Mi2-Mi1-Hi)			dB	
Unit drain pipe I.D.			mm (in.)	
Dimensions	W	mm (in.)	UNIT : 840 (33-1/16) PANEL : 950 (37-3/8)	
	D	mm (in.)	UNIT : 840 (33-1/16) PANEL : 950 (37-3/8)	
	H	mm (in.)	UNIT : 298 (11-3/4) PANEL : 30 (1-3/16)	
Weight			kg (lbs.)	
Weight			UNIT : 34 (75) PANEL : 5 (11)	
Service Ref.			PUH-P6YGAA.UK	
Power supply (phase, cycle, voltage)			3 phases, 50Hz, 380-400-415V (4wires)	
Running current	A		9.03	9.56
Starting current	A		74	
External finish			Munsell 5Y 7/1	
Refrigerant control			Linear expansion valve	
Compressor			Hermetic	
Model			ZR72KCE-TFD	
Motor output			kW	
Starter type			Line start	
Protection devices			Internal thermostat, Thermal relay, HP switch, Discharge thermo.	
Heat exchanger			Plate fin coil	
Fan	Fan (drive) × No.		Propeller (direct) × 2	
	Fan motor output		kW	
	Airflow		m ³ / min (CFM)	
Crankcase heater			W	
Defrost method			Reverse cycle	
Sound level	Cooling	dB	57	
	Heating	dB	58	
Dimensions	W	mm (in.)	1,050 (41-5/16)	
	D	mm (in.)	330+20(13+3/4)	
	H	mm (in.)	1,260 (49-5/8)	
Weight			kg (lbs.)	
Weight			122 (269)	
Refrigerant			R407C	
Charge	kg (lbs.)		4.9 (10.8)	
	Oil (Model)		L	
Oil (Model)			1.774 (Ester) MMA-POE	
Pipe size O.D.	Liquid	mm (in.)	9.52 (3/8)	
	Gas	mm (in.)	19.05 (3/4)	
Connection method	Indoor side		Flared	
	Outdoor side		Flared	
Between the indoor & outdoor units	Height difference		Max. 50m	
	Piping length		Max. 50m	

NOTE: 1. Rating conditions (ISO T1)
Cooling : Indoor : D.B. 27°C (80°F), W.B. 19°C (66°F) Outdoor : D.B. 35°C (95°F) W.B. 24°C (75°F)
Heating : Indoor : D.B. 20°C (68°F) Outdoor : D.B. 7°C (45°F) W.B. 6°C (43°F)
Refrigerant piping length (one way) : 5m (16ft.)

2. Guaranteed operating range

		Indoor	Outdoor
Cooling	Upper limit	D.B. 35°C, W.B. 22.5°C	D.B. 46°C
	Lower limit	D.B. 19°C, W.B. 15°C	D.B. -5°C
Heating	Upper limit	D.B. 28°C	D.B. 24°C, W.B. 18°C
	Lower limit	D.B. 17°C	D.B. -11°C, W.B. -12°C

※1 : [] Shows the total rating.

※2 : < > Shows the only booster heater rating.

3. Above data based on indicated voltage
Indoor unit Single phase 240V 50Hz
Outdoor unit 3 phases 415V 50Hz

1. PERFORMANCE DATA

1.1 COOLING CAPACITY (1)

PLH-P3AAH.UK / PUH-P3VGA, PUH-P3YGA

(240V)

Indoor intake air DB (°C)	Indoor intake air WB (°C)	Outdoor intake air DB (°C)											
		20				25				30			
		CA	SHC	SHF	P.C.	CA	SHC	SHF	P.C.	CA	SHC	SHF	P.C.
20	16	7,722	4,942	0.64	2.81	7,488	4,792	0.64	2.97	7,254	4,643	0.64	3.14
20	18	8,268	4,299	0.52	2.86	8,034	4,178	0.52	3.02	7,761	4,036	0.52	3.23
20	20	8,892	3,557	0.40	2.95	8,697	3,479	0.40	3.09	8,463	3,385	0.40	3.30
22	16	7,722	5,560	0.72	2.81	7,488	5,391	0.72	2.97	7,254	5,223	0.72	3.14
22	18	8,268	4,961	0.60	2.86	8,034	4,820	0.60	3.02	7,761	4,657	0.60	3.23
22	20	8,892	4,268	0.48	2.95	8,697	4,175	0.48	3.09	8,463	4,062	0.48	3.30
24	16	7,722	6,178	0.80	2.81	7,488	5,990	0.80	2.97	7,254	5,803	0.80	3.14
24	18	8,268	5,622	0.68	2.86	8,034	5,463	0.68	3.02	7,761	5,277	0.68	3.23
24	20	8,892	4,980	0.56	2.95	8,697	4,870	0.56	3.09	8,463	4,739	0.56	3.30
24	22	9,477	4,170	0.44	3.02	9,282	4,084	0.44	3.19	9,048	3,981	0.44	3.40
26	16	7,722	6,795	0.88	2.81	7,488	6,589	0.88	2.97	7,254	6,384	0.88	3.14
26	18	8,268	6,284	0.76	2.86	8,034	6,106	0.76	3.02	7,761	5,898	0.76	3.23
26	20	8,892	5,691	0.64	2.95	8,697	5,566	0.64	3.09	8,463	5,416	0.64	3.30
26	22	9,477	4,928	0.52	3.02	9,282	4,827	0.52	3.19	9,048	4,705	0.52	3.40
28	16	7,722	7,413	0.96	2.81	7,488	7,188	0.96	2.97	7,254	6,964	0.96	3.14
28	18	8,268	6,945	0.84	2.86	8,034	6,749	0.84	3.02	7,761	6,519	0.84	3.23
28	20	8,892	6,402	0.72	2.95	8,697	6,262	0.72	3.09	8,463	6,093	0.72	3.30
28	22	9,477	5,686	0.60	3.02	9,282	5,569	0.60	3.19	9,048	5,429	0.60	3.40
30	16	7,722	7,722	1.00	2.81	7,488	7,488	1.00	2.97	7,254	7,254	1.00	3.14
30	18	8,268	7,607	0.92	2.86	8,034	7,391	0.92	3.02	7,761	7,140	0.92	3.23
30	20	8,892	7,114	0.80	2.95	8,697	6,958	0.80	3.09	8,463	6,770	0.80	3.30
30	22	9,477	6,444	0.68	3.02	9,282	6,312	0.68	3.19	9,048	6,153	0.68	3.40
32	16	7,722	7,722	1.00	2.81	7,488	7,488	1.00	2.97	7,254	7,254	1.00	3.14
32	18	8,268	8,268	1.00	2.86	8,034	8,034	1.00	3.02	7,761	7,761	1.00	3.23
32	20	8,892	7,825	0.88	2.95	8,697	7,653	0.88	3.09	8,463	7,447	0.88	3.30
32	22	9,477	7,203	0.76	3.02	9,282	7,054	0.76	3.19	9,048	6,876	0.76	3.40
34	16	7,722	7,722	1.00	2.81	7,488	7,488	1.00	2.97	7,254	7,254	1.00	3.14
34	18	8,268	8,268	1.00	2.86	8,034	8,034	1.00	3.02	7,761	7,761	1.00	3.23
34	20	8,892	8,536	0.96	2.95	8,697	8,349	0.96	3.09	8,463	8,124	0.96	3.30
34	22	9,477	7,961	0.84	3.02	9,282	7,797	0.84	3.19	9,048	7,600	0.84	3.40

NOTE: CA: Capacity (W)

SHC: Sensible heat capacity (W)

P.C.: Power consumption (kW)

SHF: Sensible heat factor

COOLING CAPACITY (2)

PLH-P3AAH.UK / PUH-P3VGA, PUH-P3YGA

(240V)

Indoor intake air DB (°C)	Indoor intake air WB (°C)	Outdoor intake air DB (°C)											
		35				40				45			
		CA	SHC	SHF	P.C.	CA	SHC	SHF	P.C.	CA	SHC	SHF	P.C.
20	16	6,942	4,443	0.64	3.37	6,630	4,243	0.64	3.62	6,318	4,044	0.64	3.91
20	18	7,488	3,894	0.52	3.46	7,254	3,772	0.52	3.72	6,786	3,529	0.52	4.00
20	20	8,112	3,245	0.40	3.55	7,800	3,120	0.40	3.79	7,332	2,933	0.40	4.07
22	16	6,942	4,998	0.72	3.37	6,630	4,774	0.72	3.62	6,318	4,549	0.72	3.91
22	18	7,488	4,493	0.60	3.46	7,254	4,352	0.60	3.72	6,786	4,072	0.60	4.00
22	20	8,112	3,894	0.48	3.55	7,800	3,744	0.48	3.79	7,332	3,519	0.48	4.07
24	16	6,942	5,554	0.80	3.37	6,630	5,304	0.80	3.62	6,318	5,054	0.80	3.91
24	18	7,488	5,092	0.68	3.46	7,254	4,933	0.68	3.72	6,786	4,614	0.68	4.00
24	20	8,112	4,543	0.56	3.55	7,800	4,368	0.56	3.79	7,332	4,106	0.56	4.07
24	22	8,736	3,844	0.44	3.62	8,424	3,707	0.44	3.90	7,956	3,501	0.44	4.14
26	16	6,942	6,109	0.88	3.37	6,630	5,834	0.88	3.62	6,318	5,560	0.88	3.91
26	18	7,488	5,691	0.76	3.46	7,254	5,513	0.76	3.72	6,786	5,157	0.76	4.00
26	20	8,112	5,192	0.64	3.55	7,800	4,992	0.64	3.79	7,332	4,692	0.64	4.07
26	22	8,736	4,543	0.52	3.62	8,424	4,380	0.52	3.90	7,956	4,137	0.52	4.14
28	16	6,942	6,664	0.96	3.37	6,630	6,365	0.96	3.62	6,318	6,065	0.96	3.91
28	18	7,488	6,290	0.84	3.46	7,254	6,093	0.84	3.72	6,786	5,700	0.84	4.00
28	20	8,112	5,841	0.72	3.55	7,800	5,616	0.72	3.79	7,332	5,279	0.72	4.07
28	22	8,736	5,242	0.60	3.62	8,424	5,054	0.60	3.90	7,956	4,774	0.60	4.14
30	16	6,942	6,942	1.00	3.37	6,630	6,630	1.00	3.62	6,318	6,318	1.00	3.91
30	18	7,488	6,889	0.92	3.46	7,254	6,674	0.92	3.72	6,786	6,243	0.92	4.00
30	20	8,112	6,490	0.80	3.55	7,800	6,240	0.80	3.79	7,332	5,866	0.80	4.07
30	22	8,736	5,940	0.68	3.62	8,424	5,728	0.68	3.90	7,956	5,410	0.68	4.14
32	16	6,942	6,942	1.00	3.37	6,630	6,630	1.00	3.62	6,318	6,318	1.00	3.91
32	18	7,488	7,488	1.00	3.46	7,254	7,254	1.00	3.72	6,786	6,786	1.00	4.00
32	20	8,112	7,139	0.88	3.55	7,800	6,864	0.88	3.79	7,332	6,452	0.88	4.07
32	22	8,736	6,639	0.76	3.62	8,424	6,402	0.76	3.90	7,956	6,047	0.76	4.14
34	16	6,942	6,942	1.00	3.37	6,630	6,630	1.00	3.62	6,318	6,318	1.00	3.91
34	18	7,488	7,488	1.00	3.46	7,254	7,254	1.00	3.72	6,786	6,786	1.00	4.00
34	20	8,112	7,788	0.96	3.55	7,800	7,488	0.96	3.79	7,332	7,039	0.96	4.07
34	22	8,736	7,338	0.84	3.62	8,424	7,076	0.84	3.90	7,956	6,683	0.84	4.14

NOTE: CA: Capacity (W)

SHC: Sensible heat capacity (W)

P.C.: Power consumption (kW)

SHF: Sensible heat factor

COOLING CAPACITY (4)

PLH-P4AAH.UK / PUH-P4YGA

(240V)

Indoor intake air DB (°C)	Indoor intake air WB (°C)	Outdoor intake air DB (°C)											
		35				40				45			
		CA	SHC	SHF	P.C.	CA	SHC	SHF	P.C.	CA	SHC	SHF	P.C.
20	16	8,633	5,870	0.68	3.48	8,245	5,607	0.68	3.73	7,857	5,343	0.68	4.04
20	18	9,312	5,215	0.56	3.57	9,021	5,052	0.56	3.84	8,439	4,726	0.56	4.13
20	20	10,088	4,439	0.44	3.66	9,700	4,268	0.44	3.91	9,118	4,012	0.44	4.20
22	16	8,633	6,561	0.76	3.48	8,245	6,266	0.76	3.73	7,857	5,971	0.76	4.04
22	18	9,312	5,960	0.64	3.57	9,021	5,773	0.64	3.84	8,439	5,401	0.64	4.13
22	20	10,088	5,246	0.52	3.66	9,700	5,044	0.52	3.91	9,118	4,741	0.52	4.20
24	16	8,633	7,252	0.84	3.48	8,245	6,926	0.84	3.73	7,857	6,600	0.84	4.04
24	18	9,312	6,705	0.72	3.57	9,021	6,495	0.72	3.84	8,439	6,076	0.72	4.13
24	20	10,088	6,053	0.60	3.66	9,700	5,820	0.60	3.91	9,118	5,471	0.60	4.20
24	22	10,864	5,215	0.48	3.73	10,476	5,028	0.48	4.02	9,894	4,749	0.48	4.27
26	16	8,633	7,942	0.92	3.48	8,245	7,585	0.92	3.73	7,857	7,228	0.92	4.04
26	18	9,312	7,450	0.80	3.57	9,021	7,217	0.80	3.84	8,439	6,751	0.80	4.13
26	20	10,088	6,860	0.68	3.66	9,700	6,596	0.68	3.91	9,118	6,200	0.68	4.20
26	22	10,864	6,084	0.56	3.73	10,476	5,867	0.56	4.02	9,894	5,541	0.56	4.27
28	16	8,633	8,633	1.00	3.48	8,245	8,245	1.00	3.73	7,857	7,857	1.00	4.04
28	18	9,312	8,195	0.88	3.57	9,021	7,938	0.88	3.84	8,439	7,426	0.88	4.13
28	20	10,088	7,667	0.76	3.66	9,700	7,372	0.76	3.91	9,118	6,930	0.76	4.20
28	22	10,864	6,953	0.64	3.73	10,476	6,705	0.64	4.02	9,894	6,332	0.64	4.27
30	16	8,633	8,633	1.00	3.48	8,245	8,245	1.00	3.73	7,857	7,857	1.00	4.04
30	18	9,312	8,940	0.96	3.57	9,021	8,660	0.96	3.84	8,439	8,101	0.96	4.13
30	20	10,088	8,474	0.84	3.66	9,700	8,148	0.84	3.91	9,118	7,659	0.84	4.20
30	22	10,864	7,822	0.72	3.73	10,476	7,543	0.72	4.02	9,894	7,124	0.72	4.27
32	16	8,633	8,633	1.00	3.48	8,245	8,245	1.00	3.73	7,857	7,857	1.00	4.04
32	18	9,312	9,312	1.00	3.57	9,021	9,021	1.00	3.84	8,439	8,439	1.00	4.13
32	20	10,088	9,281	0.92	3.66	9,700	8,924	0.92	3.91	9,118	8,389	0.92	4.20
32	22	10,864	8,691	0.80	3.73	10,476	8,381	0.80	4.02	9,894	7,915	0.80	4.27
34	16	8,633	8,633	1.00	3.48	8,245	8,245	1.00	3.73	7,857	7,857	1.00	4.04
34	18	9,312	9,312	1.00	3.57	9,021	9,021	1.00	3.84	8,439	8,439	1.00	4.13
34	20	10,088	10,088	1.00	3.66	9,700	9,700	1.00	3.91	9,118	9,118	1.00	4.20
34	22	10,864	9,560	0.88	3.73	10,476	9,219	0.88	4.02	9,894	8,707	0.88	4.27

NOTE: CA: Capacity (W)

SHC: Sensible heat capacity (W)

P.C.: Power consumption (kW)

SHF: Sensible heat factor

**COOLING CAPACITY (6)
PLH-P5AAH.UK / PUH-P5YGA**

(240V)

Indoor intake air DB (°C)	Indoor intake air WB (°C)	Outdoor intake air DB (°C)											
		35				40				45			
		CA	SHC	SHF	P.C.	CA	SHC	SHF	P.C.	CA	SHC	SHF	P.C.
20	16	11,392	7,063	0.62	5.33	10,880	6,746	0.62	5.72	10,368	6,428	0.62	6.19
20	18	12,288	6,144	0.50	5.47	11,904	5,952	0.50	5.88	11,136	5,568	0.50	6.33
20	20	13,312	5,059	0.38	5.61	12,800	4,864	0.38	5.99	12,032	4,572	0.38	6.44
22	16	11,392	7,974	0.70	5.33	10,880	7,616	0.70	5.72	10,368	7,258	0.70	6.19
22	18	12,288	7,127	0.58	5.47	11,904	6,904	0.58	5.88	11,136	6,459	0.58	6.33
22	20	13,312	6,124	0.46	5.61	12,800	5,888	0.46	5.99	12,032	5,535	0.46	6.44
24	16	11,392	8,886	0.78	5.33	10,880	8,486	0.78	5.72	10,368	8,087	0.78	6.19
24	18	12,288	8,110	0.66	5.47	11,904	7,857	0.66	5.88	11,136	7,350	0.66	6.33
24	20	13,312	7,188	0.54	5.61	12,800	6,912	0.54	5.99	12,032	6,497	0.54	6.44
24	22	14,336	6,021	0.42	5.72	13,824	5,806	0.42	6.16	13,056	5,484	0.42	6.55
26	16	11,392	9,797	0.86	5.33	10,880	9,357	0.86	5.72	10,368	8,916	0.86	6.19
26	18	12,288	9,093	0.74	5.47	11,904	8,809	0.74	5.88	11,136	8,241	0.74	6.33
26	20	13,312	8,253	0.62	5.61	12,800	7,936	0.62	5.99	12,032	7,460	0.62	6.44
26	22	14,336	7,168	0.50	5.72	13,824	6,912	0.50	6.16	13,056	6,528	0.50	6.55
28	16	11,392	10,708	0.94	5.33	10,880	10,227	0.94	5.72	10,368	9,746	0.94	6.19
28	18	12,288	10,076	0.82	5.47	11,904	9,761	0.82	5.88	11,136	9,132	0.82	6.33
28	20	13,312	9,318	0.70	5.61	12,800	8,960	0.70	5.99	12,032	8,422	0.70	6.44
28	22	14,336	8,315	0.58	5.72	13,824	8,018	0.58	6.16	13,056	7,572	0.58	6.55
30	16	11,392	11,392	1.00	5.33	10,880	10,880	1.00	5.72	10,368	10,368	1.00	6.19
30	18	12,288	11,059	0.90	5.47	11,904	10,714	0.90	5.88	11,136	10,022	0.90	6.33
30	20	13,312	10,383	0.78	5.61	12,800	9,984	0.78	5.99	12,032	9,385	0.78	6.44
30	22	14,336	9,462	0.66	5.72	13,824	9,124	0.66	6.16	13,056	8,617	0.66	6.55
32	16	11,392	11,392	1.00	5.33	10,880	10,880	1.00	5.72	10,368	10,368	1.00	6.19
32	18	12,288	12,042	0.98	5.47	11,904	11,666	0.98	5.88	11,136	10,913	0.98	6.33
32	20	13,312	11,448	0.86	5.61	12,800	11,008	0.86	5.99	12,032	10,348	0.86	6.44
32	22	14,336	10,609	0.74	5.72	13,824	10,230	0.74	6.16	13,056	9,661	0.74	6.55
34	16	11,392	11,392	1.00	5.33	10,880	10,880	1.00	5.72	10,368	10,368	1.00	6.19
34	18	12,288	12,288	1.00	5.47	11,904	11,904	1.00	5.88	11,136	11,136	1.00	6.33
34	20	13,312	12,513	0.94	5.61	12,800	12,032	0.94	5.99	12,032	11,310	0.94	6.44
34	22	14,336	11,756	0.82	5.72	13,824	11,336	0.82	6.16	13,056	10,706	0.82	6.55

NOTE: CA: Capacity (W) SHC: Sensible heat capacity (W)
P.C.: Power consumption (kW) SHF: Sensible heat factor

COOLING CAPACITY (7)

PLH-P6AAH.UK / PUH-P6YGA

(240V)

Indoor intake air DB (°C)	Indoor intake air WB (°C)	Outdoor intake air DB (°C)											
		20				25				30			
		CA	SHC	SHF	P.C.	CA	SHC	SHF	P.C.	CA	SHC	SHF	P.C.
20	16	14,157	8,353	0.59	5.36	13,728	8,100	0.59	5.66	13,299	7,846	0.59	6.00
20	18	15,158	7,124	0.47	5.46	14,729	6,923	0.47	5.76	14,229	6,687	0.47	6.16
20	20	16,302	5,706	0.35	5.63	15,945	5,581	0.35	5.90	15,516	5,430	0.35	6.30
22	16	14,157	9,485	0.67	5.36	13,728	9,198	0.67	5.66	13,299	8,910	0.67	6.00
22	18	15,158	8,337	0.55	5.46	14,729	8,101	0.55	5.76	14,229	7,826	0.55	6.16
22	20	16,302	7,010	0.43	5.63	15,945	6,856	0.43	5.90	15,516	6,672	0.43	6.30
24	16	14,157	10,618	0.75	5.36	13,728	10,296	0.75	5.66	13,299	9,974	0.75	6.00
24	18	15,158	9,550	0.63	5.46	14,729	9,279	0.63	5.76	14,229	8,964	0.63	6.16
24	20	16,302	8,314	0.51	5.63	15,945	8,132	0.51	5.90	15,516	7,913	0.51	6.30
24	22	17,375	6,776	0.39	5.76	17,017	6,637	0.39	6.10	16,588	6,469	0.39	6.50
26	16	14,157	11,750	0.83	5.36	13,728	11,394	0.83	5.66	13,299	11,038	0.83	6.00
26	18	15,158	10,762	0.71	5.46	14,729	10,458	0.71	5.76	14,229	10,102	0.71	6.16
26	20	16,302	9,618	0.59	5.63	15,945	9,407	0.59	5.90	15,516	9,154	0.59	6.30
26	22	17,375	8,166	0.47	5.76	17,017	7,998	0.47	6.10	16,588	7,796	0.47	6.50
28	16	14,157	12,883	0.91	5.36	13,728	12,492	0.91	5.66	13,299	12,102	0.91	6.00
28	18	15,158	11,975	0.79	5.46	14,729	11,636	0.79	5.76	14,229	11,241	0.79	6.16
28	20	16,302	10,922	0.67	5.63	15,945	10,683	0.67	5.90	15,516	10,395	0.67	6.30
28	22	17,375	9,556	0.55	5.76	17,017	9,359	0.55	6.10	16,588	9,123	0.55	6.50
30	16	14,157	14,015	0.99	5.36	13,728	13,591	0.99	5.66	13,299	13,166	0.99	6.00
30	18	15,158	13,187	0.87	5.46	14,729	12,814	0.87	5.76	14,229	12,379	0.87	6.16
30	20	16,302	12,227	0.75	5.63	15,945	11,958	0.75	5.90	15,516	11,637	0.75	6.30
30	22	17,375	10,946	0.63	5.76	17,017	10,721	0.63	6.10	16,588	10,450	0.63	6.50
32	16	14,157	14,157	1.00	5.36	13,728	13,728	1.00	5.66	13,299	13,299	1.00	6.00
32	18	15,158	14,400	0.95	5.46	14,729	13,993	0.95	5.76	14,229	13,517	0.95	6.16
32	20	16,302	13,531	0.83	5.63	15,945	13,234	0.83	5.90	15,516	12,878	0.83	6.30
32	22	17,375	12,336	0.71	5.76	17,017	12,082	0.71	6.10	16,588	11,777	0.71	6.50
34	16	14,157	14,157	1.00	5.36	13,728	13,728	1.00	5.66	13,299	13,299	1.00	6.00
34	18	15,158	15,158	1.00	5.46	14,729	14,729	1.00	5.76	14,229	14,229	1.00	6.16
34	20	16,302	14,835	0.91	5.63	15,945	14,509	0.91	5.90	15,516	14,119	0.91	6.30
34	22	17,375	13,726	0.79	5.76	17,017	13,443	0.79	6.10	16,588	13,105	0.79	6.50

NOTE: CA: Capacity (W) SHC: Sensible heat capacity (W)
P.C.: Power consumption (kW) SHF: Sensible heat factor

COOLING CAPACITY (9)

PLH-P3AAH.UK, PLH-P3AAH₁.UK / PUH-P3VGAA.UK, PUH-P3YGAA.UK

(240V)

Indoor intake air DB (°C)	Indoor intake air WB (°C)	Outdoor intake air DB (°C)											
		20				25				30			
		CA	SHC	SHF	P.C.	CA	SHC	SHF	P.C.	CA	SHC	SHF	P.C.
20	16	7,722	4,942	0.64	2.75	7,488	4,792	0.64	2.91	7,254	4,643	0.64	3.08
20	18	8,268	4,299	0.52	2.80	8,034	4,178	0.52	2.96	7,761	4,036	0.52	3.16
20	20	8,892	3,557	0.40	2.89	8,697	3,479	0.40	3.03	8,463	3,385	0.40	3.23
22	16	7,722	5,560	0.72	2.75	7,488	5,391	0.72	2.91	7,254	5,223	0.72	3.08
22	18	8,268	4,961	0.60	2.80	8,034	4,820	0.60	2.96	7,761	4,657	0.60	3.16
22	20	8,892	4,268	0.48	2.89	8,697	4,175	0.48	3.03	8,463	4,062	0.48	3.23
24	16	7,722	6,178	0.80	2.75	7,488	5,990	0.80	2.91	7,254	5,803	0.80	3.08
24	18	8,268	5,622	0.68	2.80	8,034	5,463	0.68	2.96	7,761	5,277	0.68	3.16
24	20	8,892	4,980	0.56	2.89	8,697	4,870	0.56	3.03	8,463	4,739	0.56	3.23
26	16	7,722	6,795	0.88	2.75	7,488	6,589	0.88	2.91	7,254	6,384	0.88	3.08
26	18	8,268	6,284	0.76	2.80	8,034	6,106	0.76	2.96	7,761	5,898	0.76	3.16
26	20	8,892	5,691	0.64	2.89	8,697	5,566	0.64	3.03	8,463	5,416	0.64	3.23
28	16	7,722	7,413	0.96	2.75	7,488	7,188	0.96	2.91	7,254	6,964	0.96	3.08
28	18	8,268	6,945	0.84	2.80	8,034	6,749	0.84	2.96	7,761	6,519	0.84	3.16
28	20	8,892	6,402	0.72	2.89	8,697	6,262	0.72	3.03	8,463	6,093	0.72	3.23
30	16	7,722	7,722	1.00	2.75	7,488	7,488	1.00	2.91	7,254	7,254	1.00	3.08
30	18	8,268	7,607	0.92	2.80	8,034	7,391	0.92	2.96	7,761	7,140	0.92	3.16
30	20	8,892	7,114	0.80	2.89	8,697	6,958	0.80	3.03	8,463	6,770	0.80	3.23
32	16	7,722	7,722	1.00	2.75	7,488	7,488	1.00	2.91	7,254	7,254	1.00	3.08
32	18	8,268	8,268	1.00	2.80	8,034	8,034	1.00	2.96	7,761	7,761	1.00	3.16
32	20	8,892	7,825	0.88	2.89	8,697	7,653	0.88	3.03	8,463	7,447	0.88	3.23
34	16	7,722	7,722	1.00	2.75	7,488	7,488	1.00	2.91	7,254	7,254	1.00	3.08
34	18	8,268	8,268	1.00	2.80	8,034	8,034	1.00	2.96	7,761	7,761	1.00	3.16
34	20	8,892	8,536	0.96	2.89	8,697	8,349	0.96	3.03	8,463	8,124	0.96	3.23

NOTE: CA: Capacity (W) SHC: Sensible heat capacity (W)
P.C.: Power consumption (kW) SHF: Sensible heat factor

COOLING CAPACITY (10)

PLH-P3AAH.UK, PLH-P3AAH₁.UK / PUH-P3VGAA.UK, PUH-P3YGAA.UK

(240V)

Indoor intake air DB (°C)	Indoor intake air WB (°C)	Outdoor intake air DB (°C)											
		35				40				45			
		CA	SHC	SHF	P.C.	CA	SHC	SHF	P.C.	CA	SHC	SHF	P.C.
20	16	6,942	4,443	0.64	3.30	6,630	4,243	0.64	3.54	6,318	4,044	0.64	3.84
20	18	7,488	3,894	0.52	3.39	7,254	3,772	0.52	3.65	6,786	3,529	0.52	3.92
20	20	8,112	3,245	0.40	3.47	7,800	3,120	0.40	3.72	7,332	2,933	0.40	3.99
22	16	6,942	4,998	0.72	3.30	6,630	4,774	0.72	3.54	6,318	4,549	0.72	3.84
22	18	7,488	4,493	0.60	3.39	7,254	4,352	0.60	3.65	6,786	4,072	0.60	3.92
22	20	8,112	3,894	0.48	3.47	7,800	3,744	0.48	3.72	7,332	3,519	0.48	3.99
24	16	6,942	5,554	0.80	3.30	6,630	5,304	0.80	3.54	6,318	5,054	0.80	3.84
24	18	7,488	5,092	0.68	3.39	7,254	4,933	0.68	3.65	6,786	4,614	0.68	3.92
24	20	8,112	4,543	0.56	3.47	7,800	4,368	0.56	3.72	7,332	4,106	0.56	3.99
26	16	6,942	6,109	0.88	3.30	6,630	5,834	0.88	3.54	6,318	5,560	0.88	3.84
26	18	7,488	5,691	0.76	3.39	7,254	5,513	0.76	3.65	6,786	5,157	0.76	3.92
26	20	8,112	5,192	0.64	3.47	7,800	4,992	0.64	3.72	7,332	4,692	0.64	3.99
28	16	6,942	6,664	0.96	3.30	6,630	6,365	0.96	3.54	6,318	6,065	0.96	3.84
28	18	7,488	6,290	0.84	3.39	7,254	6,093	0.84	3.65	6,786	5,700	0.84	3.92
28	20	8,112	5,841	0.72	3.47	7,800	5,616	0.72	3.72	7,332	5,279	0.72	3.99
30	16	6,942	6,942	1.00	3.30	6,630	6,630	1.00	3.54	6,318	6,318	1.00	3.84
30	18	7,488	6,889	0.92	3.39	7,254	6,674	0.92	3.65	6,786	6,243	0.92	3.92
30	20	8,112	6,490	0.80	3.47	7,800	6,240	0.80	3.72	7,332	5,866	0.80	3.99
32	16	6,942	6,942	1.00	3.30	6,630	6,630	1.00	3.54	6,318	6,318	1.00	3.84
32	18	7,488	7,488	1.00	3.39	7,254	7,254	1.00	3.65	6,786	6,786	1.00	3.92
32	20	8,112	7,139	0.88	3.47	7,800	6,864	0.88	3.72	7,332	6,452	0.88	3.99
34	16	6,942	6,942	1.00	3.30	6,630	6,630	1.00	3.54	6,318	6,318	1.00	3.84
34	18	7,488	7,488	1.00	3.39	7,254	7,254	1.00	3.65	6,786	6,786	1.00	3.92
34	20	8,112	7,788	0.96	3.47	7,800	7,488	0.96	3.72	7,332	7,039	0.96	3.99

NOTE: CA: Capacity (W) SHC: Sensible heat capacity (W)
P.C.: Power consumption (kW) SHF: Sensible heat factor

COOLING CAPACITY (11)

PLH-P4AAH.UK, PLH-P4AAH₁.UK / PUH-P4VGAA.UK, PUH-P4YGAA.UK

(240V)

Indoor intake air DB (°C)	Indoor intake air WB (°C)	Outdoor intake air DB (°C)											
		20				25				30			
		CA	SHC	SHF	P.C.	CA	SHC	SHF	P.C.	CA	SHC	SHF	P.C.
20	16	9,603	6,530	0.68	2.95	9,312	6,332	0.68	3.12	9,021	6,134	0.68	3.30
20	18	10,282	5,758	0.56	3.01	9,991	5,595	0.56	3.17	9,652	5,405	0.56	3.39
20	20	11,058	4,866	0.44	3.10	10,816	4,759	0.44	3.25	10,525	4,631	0.44	3.47
22	16	9,603	7,298	0.76	2.95	9,312	7,077	0.76	3.12	9,021	6,856	0.76	3.30
22	18	10,282	6,580	0.64	3.01	9,991	6,394	0.64	3.17	9,652	6,177	0.64	3.39
22	20	11,058	5,750	0.52	3.10	10,816	5,624	0.52	3.25	10,525	5,473	0.52	3.47
24	16	9,603	8,067	0.84	2.95	9,312	7,822	0.84	3.12	9,021	7,578	0.84	3.30
24	18	10,282	7,403	0.72	3.01	9,991	7,194	0.72	3.17	9,652	6,949	0.72	3.39
24	20	11,058	6,635	0.60	3.10	10,816	6,489	0.60	3.25	10,525	6,315	0.60	3.47
26	16	9,603	8,835	0.92	2.95	9,312	8,567	0.92	3.12	9,021	8,299	0.92	3.30
26	18	10,282	8,226	0.80	3.01	9,991	7,993	0.80	3.17	9,652	7,721	0.80	3.39
26	20	11,058	7,519	0.68	3.10	10,816	7,355	0.68	3.25	10,525	7,157	0.68	3.47
28	16	9,603	9,603	1.00	2.95	9,312	9,312	1.00	3.12	9,021	9,021	1.00	3.30
28	18	10,282	9,048	0.88	3.01	9,991	8,792	0.88	3.17	9,652	8,493	0.88	3.39
28	20	11,058	8,404	0.76	3.10	10,816	8,220	0.76	3.25	10,525	7,999	0.76	3.47
30	16	9,603	9,603	1.00	2.95	9,312	9,312	1.00	3.12	9,021	9,021	1.00	3.30
30	18	10,282	9,871	0.96	3.01	9,991	9,591	0.96	3.17	9,652	9,265	0.96	3.39
30	20	11,058	9,289	0.84	3.10	10,816	9,085	0.84	3.25	10,525	8,841	0.84	3.47
32	16	9,603	9,603	1.00	2.95	9,312	9,312	1.00	3.12	9,021	9,021	1.00	3.30
32	18	10,282	10,282	1.00	3.01	9,991	9,991	1.00	3.17	9,652	9,652	1.00	3.39
32	20	11,058	10,173	0.92	3.10	10,816	9,950	0.92	3.25	10,525	9,683	0.92	3.47
34	16	9,603	9,603	1.00	2.95	9,312	9,312	1.00	3.12	9,021	9,021	1.00	3.30
34	18	10,282	10,282	1.00	3.01	9,991	9,991	1.00	3.17	9,652	9,652	1.00	3.39
34	20	11,058	11,058	1.00	3.10	10,816	10,816	1.00	3.25	10,525	10,525	1.00	3.47

NOTE: CA: Capacity (W) SHC: Sensible heat capacity (W)
P.C.: Power consumption (kW) SHF: Sensible heat factor

COOLING CAPACITY (12)

PLH-P4AAH.UK, PLH-P4AAH₁.UK / PUH-P4VGAA.UK, PUH-P4YGAA.UK

(240V)

Indoor intake air DB (°C)	Indoor intake air WB (°C)	Outdoor intake air DB (°C)											
		35				40				45			
		CA	SHC	SHF	P.C.	CA	SHC	SHF	P.C.	CA	SHC	SHF	P.C.
20	16	8,633	5,870	0.68	3.54	8,245	5,607	0.68	3.80	7,857	5,343	0.68	4.11
20	18	9,312	5,215	0.56	3.63	9,021	5,052	0.56	3.91	8,439	4,726	0.56	4.21
20	20	10,088	4,439	0.44	3.73	9,700	4,268	0.44	3.99	9,118	4,012	0.44	4.28
22	16	8,633	6,561	0.76	3.54	8,245	6,266	0.76	3.80	7,857	5,971	0.76	4.11
22	18	9,312	5,960	0.64	3.63	9,021	5,773	0.64	3.91	8,439	5,401	0.64	4.21
22	20	10,088	5,246	0.52	3.73	9,700	5,044	0.52	3.99	9,118	4,741	0.52	4.28
24	16	8,633	7,252	0.84	3.54	8,245	6,926	0.84	3.80	7,857	6,600	0.84	4.11
24	18	9,312	6,705	0.72	3.63	9,021	6,495	0.72	3.91	8,439	6,076	0.72	4.21
24	20	10,088	6,053	0.60	3.73	9,700	5,820	0.60	3.99	9,118	5,471	0.60	4.28
26	16	8,633	7,942	0.92	3.54	8,245	7,585	0.92	3.80	7,857	7,228	0.92	4.11
26	18	9,312	7,450	0.80	3.63	9,021	7,217	0.80	3.91	8,439	6,751	0.80	4.21
26	20	10,088	6,860	0.68	3.73	9,700	6,596	0.68	3.99	9,118	6,200	0.68	4.28
28	16	8,633	8,633	1.00	3.54	8,245	8,245	1.00	3.80	7,857	7,857	1.00	4.11
28	18	9,312	8,195	0.88	3.63	9,021	7,938	0.88	3.91	8,439	7,426	0.88	4.21
28	20	10,088	7,667	0.76	3.73	9,700	7,372	0.76	3.99	9,118	6,930	0.76	4.28
30	16	8,633	8,633	1.00	3.54	8,245	8,245	1.00	3.80	7,857	7,857	1.00	4.11
30	18	9,312	8,940	0.96	3.63	9,021	8,660	0.96	3.91	8,439	8,101	0.96	4.21
30	20	10,088	8,474	0.84	3.73	9,700	8,148	0.84	3.99	9,118	7,659	0.84	4.28
32	16	8,633	8,633	1.00	3.54	8,245	8,245	1.00	3.80	7,857	7,857	1.00	4.11
32	18	9,312	9,312	1.00	3.63	9,021	9,021	1.00	3.91	8,439	8,439	1.00	4.21
32	20	10,088	9,281	0.92	3.73	9,700	8,924	0.92	3.99	9,118	8,389	0.92	4.28
34	16	8,633	8,633	1.00	3.54	8,245	8,245	1.00	3.80	7,857	7,857	1.00	4.11
34	18	9,312	9,312	1.00	3.63	9,021	9,021	1.00	3.91	8,439	8,439	1.00	4.21
34	20	10,088	10,088	1.00	3.73	9,700	9,700	1.00	3.99	9,118	9,118	1.00	4.28

NOTE: CA: Capacity (W) SHC: Sensible heat capacity (W)
P.C.: Power consumption (kW) SHF: Sensible heat factor

COOLING CAPACITY (13)

PLH-P5AAH.UK, PLH-P5AAH₁.UK / PUH-P5YGAA.UK

(240V)

Indoor intake air DB (°C)	Indoor intake air WB (°C)	Outdoor intake air DB (°C)											
		20				25				30			
		CA	SHC	SHF	P.C.	CA	SHC	SHF	P.C.	CA	SHC	SHF	P.C.
20	16	12,672	7,857	0.62	4.00	12,288	7,619	0.62	4.23	11,904	7,380	0.62	4.48
20	18	13,568	6,784	0.50	4.08	13,184	6,592	0.50	4.30	12,736	6,368	0.50	4.60
20	20	14,592	5,545	0.38	4.20	14,272	5,423	0.38	4.40	13,888	5,277	0.38	4.70
22	16	12,672	8,870	0.70	4.00	12,288	8,602	0.70	4.23	11,904	8,333	0.70	4.48
22	18	13,568	7,869	0.58	4.08	13,184	7,647	0.58	4.30	12,736	7,387	0.58	4.60
22	20	14,592	6,712	0.46	4.20	14,272	6,565	0.46	4.40	13,888	6,388	0.46	4.70
24	16	12,672	9,884	0.78	4.00	12,288	9,585	0.78	4.23	11,904	9,285	0.78	4.48
24	18	13,568	8,955	0.66	4.08	13,184	8,701	0.66	4.30	12,736	8,406	0.66	4.60
24	20	14,592	7,880	0.54	4.20	14,272	7,707	0.54	4.40	13,888	7,500	0.54	4.70
26	16	12,672	10,898	0.86	4.00	12,288	10,568	0.86	4.23	11,904	10,237	0.86	4.48
26	18	13,568	10,040	0.74	4.08	13,184	9,756	0.74	4.30	12,736	9,425	0.74	4.60
26	20	14,592	9,047	0.62	4.20	14,272	8,849	0.62	4.40	13,888	8,611	0.62	4.70
28	16	12,672	11,912	0.94	4.00	12,288	11,551	0.94	4.23	11,904	11,190	0.94	4.48
28	18	13,568	11,126	0.82	4.08	13,184	10,811	0.82	4.30	12,736	10,444	0.82	4.60
28	20	14,592	10,214	0.70	4.20	14,272	9,990	0.70	4.40	13,888	9,722	0.70	4.70
30	16	12,672	12,672	1.00	4.00	12,288	12,288	1.00	4.23	11,904	11,904	1.00	4.48
30	18	13,568	12,211	0.90	4.08	13,184	11,866	0.90	4.30	12,736	11,462	0.90	4.60
30	20	14,592	11,382	0.78	4.20	14,272	11,132	0.78	4.40	13,888	10,833	0.78	4.70
32	16	12,672	12,672	1.00	4.00	12,288	12,288	1.00	4.23	11,904	11,904	1.00	4.48
32	18	13,568	13,297	0.98	4.08	13,184	12,920	0.98	4.30	12,736	12,481	0.98	4.60
32	20	14,592	12,549	0.86	4.20	14,272	12,274	0.86	4.40	13,888	11,944	0.86	4.70
34	16	12,672	12,672	1.00	4.00	12,288	12,288	1.00	4.23	11,904	11,904	1.00	4.48
34	18	13,568	13,568	1.00	4.08	13,184	13,184	1.00	4.30	12,736	12,736	1.00	4.60
34	20	14,592	13,716	0.94	4.20	14,272	13,416	0.94	4.40	13,888	13,055	0.94	4.70

NOTE: CA: Capacity (W)
P.C.: Power consumption (kW)

SHC: Sensible heat capacity (W)
SHF: Sensible heat factor

COOLING CAPACITY (14)

PLH-P5AAH.UK, PLH-P5AAH₁.UK / PUH-P5YGAA.UK

(240V)

Indoor intake air DB (°C)	Indoor intake air WB (°C)	Outdoor intake air DB (°C)											
		35				40				45			
		CA	SHC	SHF	P.C.	CA	SHC	SHF	P.C.	CA	SHC	SHF	P.C.
20	16	11,392	7,063	0.62	4.80	10,880	6,746	0.62	5.15	10,368	6,428	0.62	5.58
20	18	12,288	6,144	0.50	4.93	11,904	5,952	0.50	5.30	11,136	5,568	0.50	5.70
20	20	13,312	5,059	0.38	5.05	12,800	4,864	0.38	5.40	12,032	4,572	0.38	5.80
22	16	11,392	7,974	0.70	4.80	10,880	7,616	0.70	5.15	10,368	7,258	0.70	5.58
22	18	12,288	7,127	0.58	4.93	11,904	6,904	0.58	5.30	11,136	6,459	0.58	5.70
22	20	13,312	6,124	0.46	5.05	12,800	5,888	0.46	5.40	12,032	5,535	0.46	5.80
24	16	11,392	8,886	0.78	4.80	10,880	8,486	0.78	5.15	10,368	8,087	0.78	5.58
24	18	12,288	8,110	0.66	4.93	11,904	7,857	0.66	5.30	11,136	7,350	0.66	5.70
24	20	13,312	7,188	0.54	5.05	12,800	6,912	0.54	5.40	12,032	6,497	0.54	5.80
26	16	11,392	9,797	0.86	4.80	10,880	9,357	0.86	5.15	10,368	8,916	0.86	5.58
26	18	12,288	9,093	0.74	4.93	11,904	8,809	0.74	5.30	11,136	8,241	0.74	5.70
26	20	13,312	8,253	0.62	5.05	12,800	7,936	0.62	5.40	12,032	7,460	0.62	5.80
28	16	11,392	10,708	0.94	4.80	10,880	10,227	0.94	5.15	10,368	9,746	0.94	5.58
28	18	12,288	10,076	0.82	4.93	11,904	9,761	0.82	5.30	11,136	9,132	0.82	5.70
28	20	13,312	9,318	0.70	5.05	12,800	8,960	0.70	5.40	12,032	8,422	0.70	5.80
30	16	11,392	11,392	1.00	4.80	10,880	10,880	1.00	5.15	10,368	10,368	1.00	5.58
30	18	12,288	11,059	0.90	4.93	11,904	10,714	0.90	5.30	11,136	10,022	0.90	5.70
30	20	13,312	10,383	0.78	5.05	12,800	9,984	0.78	5.40	12,032	9,385	0.78	5.80
32	16	11,392	11,392	1.00	4.80	10,880	10,880	1.00	5.15	10,368	10,368	1.00	5.58
32	18	12,288	12,042	0.98	4.93	11,904	11,666	0.98	5.30	11,136	10,913	0.98	5.70
32	20	13,312	11,448	0.86	5.05	12,800	11,008	0.86	5.40	12,032	10,348	0.86	5.80
34	16	11,392	11,392	1.00	4.80	10,880	10,880	1.00	5.15	10,368	10,368	1.00	5.58
34	18	12,288	12,288	1.00	4.93	11,904	11,904	1.00	5.30	11,136	11,136	1.00	5.70
34	20	13,312	12,513	0.94	5.05	12,800	12,032	0.94	5.40	12,032	11,310	0.94	5.80

NOTE: CA: Capacity (W) SHC: Sensible heat capacity (W)
P.C.: Power consumption (kW) SHF: Sensible heat factor

COOLING CAPACITY (15)

PLH-P6AAH.UK, PLH-P6AAH₁.UK / PUH-P6YGAA.UK

(240V)

Indoor intake air DB (°C)	Indoor intake air WB (°C)	Outdoor intake air DB (°C)											
		20				25				30			
		CA	SHC	SHF	P.C.	CA	SHC	SHF	P.C.	CA	SHC	SHF	P.C.
20	16	14,157	8,353	0.59	4.82	13,728	8,100	0.59	5.10	13,299	7,846	0.59	5.40
20	18	15,158	7,124	0.47	4.91	14,729	6,923	0.47	5.19	14,229	6,687	0.47	5.55
20	20	16,302	5,706	0.35	5.07	15,945	5,581	0.35	5.31	15,516	5,430	0.35	5.67
22	16	14,157	9,485	0.67	4.82	13,728	9,198	0.67	5.10	13,299	8,910	0.67	5.40
22	18	15,158	8,337	0.55	4.91	14,729	8,101	0.55	5.19	14,229	7,826	0.55	5.55
22	20	16,302	7,010	0.43	5.07	15,945	6,856	0.43	5.31	15,516	6,672	0.43	5.67
24	16	14,157	10,618	0.75	4.82	13,728	10,296	0.75	5.10	13,299	9,974	0.75	5.40
24	18	15,158	9,550	0.63	4.91	14,729	9,279	0.63	5.19	14,229	8,964	0.63	5.55
24	20	16,302	8,314	0.51	5.07	15,945	8,132	0.51	5.31	15,516	7,913	0.51	5.67
26	16	14,157	11,750	0.83	4.82	13,728	11,394	0.83	5.10	13,299	11,038	0.83	5.40
26	18	15,158	10,762	0.71	4.91	14,729	10,458	0.71	5.19	14,229	10,102	0.71	5.55
26	20	16,302	9,618	0.59	5.07	15,945	9,407	0.59	5.31	15,516	9,154	0.59	5.67
28	16	14,157	12,883	0.91	4.82	13,728	12,492	0.91	5.10	13,299	12,102	0.91	5.40
28	18	15,158	11,975	0.79	4.91	14,729	11,636	0.79	5.19	14,229	11,241	0.79	5.55
28	20	16,302	10,922	0.67	5.07	15,945	10,683	0.67	5.31	15,516	10,395	0.67	5.67
30	16	14,157	14,015	0.99	4.82	13,728	13,591	0.99	5.10	13,299	13,166	0.99	5.40
30	18	15,158	13,187	0.87	4.91	14,729	12,814	0.87	5.19	14,229	12,379	0.87	5.55
30	20	16,302	12,227	0.75	5.07	15,945	11,958	0.75	5.31	15,516	11,637	0.75	5.67
32	16	14,157	14,157	1.00	4.82	13,728	13,728	1.00	5.10	13,299	13,299	1.00	5.40
32	18	15,158	14,400	0.95	4.91	14,729	13,993	0.95	5.19	14,229	13,517	0.95	5.55
32	20	16,302	13,531	0.83	5.07	15,945	13,234	0.83	5.31	15,516	12,878	0.83	5.67
34	16	14,157	14,157	1.00	4.82	13,728	13,728	1.00	5.10	13,299	13,299	1.00	5.40
34	18	15,158	15,158	1.00	4.91	14,729	14,729	1.00	5.19	14,229	14,229	1.00	5.55
34	20	16,302	14,835	0.91	5.07	15,945	14,509	0.91	5.31	15,516	14,119	0.91	5.67

NOTE: CA: Capacity (W) SHC: Sensible heat capacity (W)
P.C.: Power consumption (kW) SHF: Sensible heat factor

COOLING CAPACITY (16)

PLH-P6AAH.UK, PLH-P6AAH₁.UK / PUH-P6YGAA.UK

(240V)

Indoor intake air DB (°C)	Indoor intake air WB (°C)	Outdoor intake air DB (°C)											
		35				40				45			
		CA	SHC	SHF	P.C.	CA	SHC	SHF	P.C.	CA	SHC	SHF	P.C.
20	16	12,727	7,509	0.59	5.79	12,155	7,171	0.59	6.21	11,583	6,834	0.59	6.72
20	18	13,728	6,452	0.47	5.94	13,299	6,251	0.47	6.39	12,441	5,847	0.47	6.87
20	20	14,872	5,205	0.35	6.09	14,300	5,005	0.35	6.51	13,442	4,705	0.35	6.99
22	16	12,727	8,527	0.67	5.79	12,155	8,144	0.67	6.21	11,583	7,761	0.67	6.72
22	18	13,728	7,550	0.55	5.94	13,299	7,314	0.55	6.39	12,441	6,843	0.55	6.87
22	20	14,872	6,395	0.43	6.09	14,300	6,149	0.43	6.51	13,442	5,780	0.43	6.99
24	16	12,727	9,545	0.75	5.79	12,155	9,116	0.75	6.21	11,583	8,687	0.75	6.72
24	18	13,728	8,649	0.63	5.94	13,299	8,378	0.63	6.39	12,441	7,838	0.63	6.87
24	20	14,872	7,585	0.51	6.09	14,300	7,293	0.51	6.51	13,442	6,855	0.51	6.99
26	16	12,727	10,563	0.83	5.79	12,155	10,089	0.83	6.21	11,583	9,614	0.83	6.72
26	18	13,728	9,747	0.71	5.94	13,299	9,442	0.71	6.39	12,441	8,833	0.71	6.87
26	20	14,872	8,774	0.59	6.09	14,300	8,437	0.59	6.51	13,442	7,931	0.59	6.99
28	16	12,727	11,582	0.91	5.79	12,155	11,061	0.91	6.21	11,583	10,541	0.91	6.72
28	18	13,728	10,845	0.79	5.94	13,299	10,506	0.79	6.39	12,441	9,828	0.79	6.87
28	20	14,872	9,964	0.67	6.09	14,300	9,581	0.67	6.51	13,442	9,006	0.67	6.99
30	16	12,727	12,600	0.99	5.79	12,155	12,033	0.99	6.21	11,583	11,467	0.99	6.72
30	18	13,728	11,943	0.87	5.94	13,299	11,570	0.87	6.39	12,441	10,824	0.87	6.87
30	20	14,872	11,154	0.75	6.09	14,300	10,725	0.75	6.51	13,442	10,082	0.75	6.99
32	16	12,727	12,727	1.00	5.79	12,155	12,155	1.00	6.21	11,583	11,583	1.00	6.72
32	18	13,728	13,042	0.95	5.94	13,299	12,634	0.95	6.39	12,441	11,819	0.95	6.87
32	20	14,872	12,344	0.83	6.09	14,300	11,869	0.83	6.51	13,442	11,157	0.83	6.99
34	16	12,727	12,727	1.00	5.79	12,155	12,155	1.00	6.21	11,583	11,583	1.00	6.72
34	18	13,728	13,728	1.00	5.94	13,299	13,299	1.00	6.39	12,441	12,441	1.00	6.87
34	20	14,872	13,534	0.91	6.09	14,300	13,013	0.91	6.51	13,442	12,232	0.91	6.99

NOTE: CA: Capacity (W)

P.C.: Power consumption (kW)

SHC: Sensible heat capacity (W)

SHF: Sensible heat factor

1.2 HEATING CAPACITY

PUH-P3VGA, PUH-P3YGA, PUH-P4YGA, PUH-P5YGA, PUH-P6YGA

(240V)

Service Ref.	Indoor intake air DB (°C)	Outdoor intake air WB (°C)											
		-10		-5		0		5		10		15	
		CA	P.C.	CA	P.C.	CA	P.C.	CA	P.C.	CA	P.C.	CA	P.C.
PLH-P3AAH.UK	15	5,906	2.15	6,417	2.37	7,161	2.74	9,393	3.29	10,602	3.65	11,811	3.94
	20	5,673	2.34	6,138	2.56	6,789	2.96	9,068	3.54	10,230	3.94	11,393	4.23
	25	5,487	2.48	5,952	2.77	6,510	3.21	8,556	3.76	9,858	4.22	10,974	4.54
PLH-P4AAH.UK	15	6,731	2.24	7,314	2.47	8,162	2.85	10,706	3.42	12,084	3.80	13,462	4.10
	20	6,466	2.43	6,996	2.66	7,738	3.08	10,335	3.69	11,660	4.10	12,985	4.41
	25	6,254	2.58	6,784	2.89	7,420	3.34	9,752	3.91	11,236	4.39	12,508	4.73
PLH-P5AAH.UK	15	10,160	3.50	11,040	3.85	12,320	4.45	16,160	5.34	18,240	5.93	20,320	6.40
	20	9,760	3.80	10,560	4.15	11,680	4.80	15,600	5.75	17,600	6.40	19,600	6.88
	25	9,440	4.03	10,240	4.51	11,200	5.22	14,720	6.11	16,960	6.85	18,880	7.38
PLH-P6AAH.UK	15	10,668	3.99	11,592	4.40	12,936	5.08	16,968	6.09	19,152	6.77	21,336	7.31
	20	10,248	4.33	11,088	4.74	12,264	5.48	16,380	6.57	18,480	7.31	20,580	7.85
	25	9,912	4.60	10,752	5.15	11,760	5.96	15,456	6.97	17,808	7.82	19,824	8.43

PUH-P3VGAA.UK, PUH-P3YGAA.UK, PUH-P4VGAA.UK, PUH-4YGAA.UK, PUH-P5YGAA.UK, PUH-P6YGAA.UK

(240V)

Service Ref.	Indoor intake air DB (°C)	Outdoor intake air WB (°C)											
		-10		-5		0		5		10		15	
		CA	P.C.	CA	P.C.	CA	P.C.	CA	P.C.	CA	P.C.	CA	P.C.
PLH-P3AAH.UK PLH-P3AAH ₁ .UK	15	5,906	2.07	6,417	2.28	7,161	2.63	9,393	3.15	10,602	3.50	11,811	3.78
	20	5,673	2.24	6,138	2.45	6,789	2.84	9,068	3.40	10,230	3.78	11,393	4.06
	25	5,487	2.38	5,952	2.66	6,510	3.08	8,556	3.61	9,858	4.04	10,974	4.36
PLH-P4AAH.UK PLH-P4AAH ₁ .UK	15	6,731	2.32	7,314	2.55	8,162	2.95	10,706	3.54	12,084	3.93	13,462	4.24
	20	6,466	2.52	6,996	2.75	7,738	3.18	10,335	3.81	11,660	4.24	12,985	4.56
	25	6,254	2.67	6,784	2.99	7,420	3.46	9,752	4.05	11,236	4.54	12,508	4.89
PLH-P5AAH.UK PLH-P5AAH ₁ .UK	15	9,462	3.15	10,281	3.47	11,473	4.01	15,049	4.81	16,986	5.34	18,923	5.77
	20	9,089	3.42	9,834	3.74	10,877	4.33	14,528	5.18	16,390	5.77	18,253	6.19
	25	8,791	3.63	9,536	4.06	10,430	4.70	13,708	5.50	15,794	6.17	17,582	6.65
PLH-P6AAH.UK PLH-P6AAH ₁ .UK	15	10,859	3.75	11,799	4.13	13,167	4.77	17,271	5.72	19,494	6.36	21,717	6.87
	20	10,431	4.07	11,286	4.45	12,483	5.15	16,673	6.17	18,810	6.87	20,948	7.38
	25	10,089	4.32	10,944	4.83	11,970	5.60	15,732	6.55	18,126	7.35	20,178	7.92

NOTE: CA: Capacity (W)

P.C.: Power consumption (kW)

1.3 Correction factors

Cooling capacity correction factors

Service Ref.	Refrigerant piping length (one way)									
	5m	10m	15m	20m	25m	30m	35m	40m	45m	50m
PLH-P3AAH.UK PLH-P3AAH:UK	1.00	0.981	0.968	0.952	0.940	0.925	0.913	0.900	0.886	0.874
PLH-P4AAH.UIK PLH-P4AAH:UK	1.00	0.989	0.980	0.970	0.960	0.950	0.940	0.930	0.920	0.910
PLH-P5AAH.UK PLH-P5AAH:UK	1.00	0.981	0.968	0.952	0.940	0.925	0.913	0.900	0.886	0.874
PLH-P6AAH.UK PLH-P6AAH:UK	1.00	0.975	0.955	0.935	0.918	0.900	0.884	0.869	0.855	0.840

Heating capacity correction factors

Service Ref.	Refrigerant piping length (one way)									
	5m	10m	15m	20m	25m	30m	35m	40m	45m	50m
PLH-P3AAH.UK PLH-P3AAH:UK	1.00	0.998	0.995	0.993	0.990	0.988	0.985	0.983	0.980	0.978
PLH-P4AAH.UK PLH-P4AAH:UK	1.00	0.998	0.995	0.993	0.990	0.988	0.985	0.983	0.980	0.978
PLH-P5AAH.UK PLH-P5AAH:UK	1.00	0.998	0.995	0.993	0.990	0.988	0.985	0.983	0.980	0.978
PLH-P6AAH.UK PLH-P6AAH:UK	1.00	0.998	0.955	0.993	0.990	0.988	0.985	0.983	0.980	0.978

2. PERFORMANCE CURVE

Cooling performance curve(50Hz)

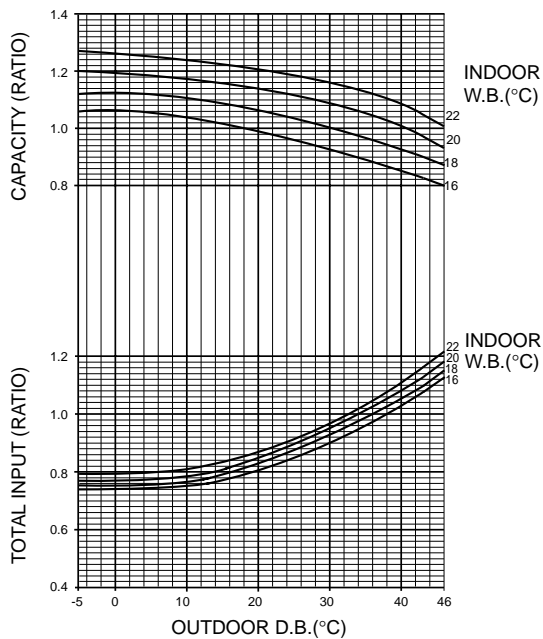

Heating performance curve(50Hz)

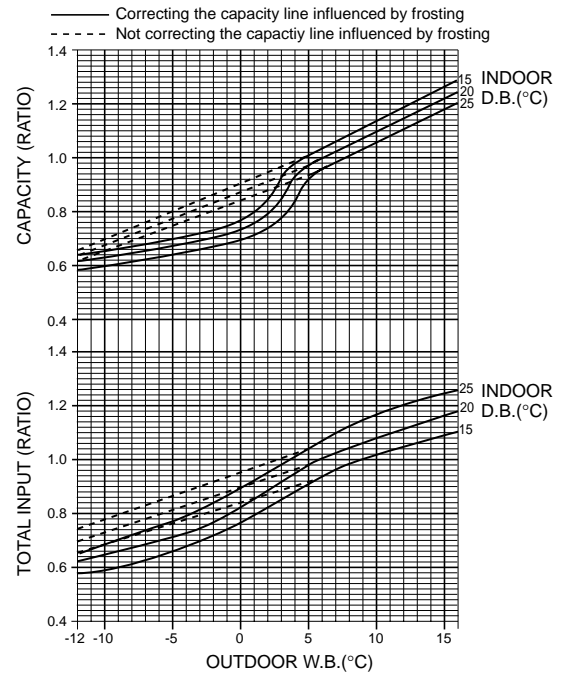

3. ELECTRICAL DATA

Indoor unit 220V 50Hz Single phase

Outdoor unit 220V 50Hz Single phase / 380V 50Hz 3 phases

Model	Indoor unit	PLH-P3AAH.UK				PLH-P4AAH.UK	
	Outdoor unit	PUH-P3VGA		PUH-P3YGA		PUH-P4YGA	
Mode		Cool	Heat	Cool	Heat	Cool	Heat
Capacity (W)		7,600	9,100 (10,860)	7,600	9,100 (10,860)	9,500	10,400 (12,580)
Total Input (kW) $\frac{(In + Out)}{(in + Out + Heater)}$		3.47	3.61 (5.37)	3.47	3.61 (5.37)	3.57	3.75 (5.93)
Indoor unit	Input (kW)	0.15	0.15 <1.76>	0.15	0.15 <1.76>	0.24	0.24 <2.18>
	Current (A)	0.78	0.78 <8.00>	0.78	0.78 <8.00>	1.25	1.25 <9.91>
Outdoor unit	Starting current (A)	84	84	38	38	41	41
	Current (A)	15.55	16.4	5.54	5.84	5.55	5.86

* () shows the total rating. < > shows the only booster heater rating.

Indoor unit 230V 50Hz Single phase

Outdoor unit 230V 50Hz Single phase / 400V 50Hz 3 phases

Model	Indoor unit	PLH-P3AAH.UK				PLH-P4AAH.UK	
	Outdoor unit	PUH-P3VGA		PUH-P3YGA		PUH-P4YGA	
Mode		Cool	Heat	Cool	Heat	Cool	Heat
Capacity (W)		7,700	9,200 (11,130)	7,700	9,200 (11,130)	9,600	10,500 (12,890)
Total Input (kW) $\frac{(In + Out)}{(in + Out + Heater)}$		3.49	3.63 (5.56)	3.49	3.63 (5.56)	3.60	3.78 (6.17)
Indoor unit	Input (kW)	0.16	0.16 <1.93>	0.16	0.16 <1.93>	0.25	0.25 <2.39>
	Current (A)	0.79	0.79 <8.39>	0.79	0.79 <8.39>	1.25	1.25 <10.39>
Outdoor unit	Starting current (A)	89	89	40	40	43	43
	Current (A)	15.08	15.89	5.46	5.75	5.48	5.78

* () shows the total rating. < > shows the only booster heater rating.

Indoor unit 240V 50Hz Single phase

Outdoor unit 240V 50Hz Single phase / 415V 50Hz 3 phases

Model	Indoor unit	PLH-P3AAH.UK				PLH-P4AAH.UK	
	Outdoor unit	PUH-P3VGA		PUH-P3YGA		PUH-P4YGA	
Mode		Cool	Heat	Cool	Heat	Cool	Heat
Capacity (W)		7,800	9,300 (11,400)	7,800	9,300 (11,400)	9,700	10,600 (13,200)
Total Input (kW) $\frac{(In + Out)}{(in + Out + Heater)}$		3.51	3.65 (5.75)	3.51	3.65 (5.75)	3.62	3.80 (6.40)
Indoor unit	Input (kW)	0.17	0.17 <2.10>	0.17	0.17 <2.10>	0.26	0.26 <2.60>
	Current (A)	0.81	0.81 <8.75>	0.81	0.81 <8.75>	1.25	1.25 <10.83>
Outdoor unit	Starting current (A)	93	93	41	41	45	45
	Current (A)	14.64	15.43	5.46	5.76	5.49	5.79

* () shows the total rating. < > shows the only booster heater rating.

Indoor unit 220V 50Hz Single phase

Outdoor unit 380V 50Hz 3 phases

Model	Indoor unit	PLH-P5AAH.UK		PLH-P6AAH.UK	
	Outdoor unit	PUH-P5YGA		PUH-P6YGA	
Mode		Cool	Heat	Cool	Heat
Capacity (W)		12,600	15,800 (18,320)	14,100	16,400 (18,920)
Total Input (kW) (In + Out) (in + Out + Heater)		5.51	5.89 (8.41)	6.60	6.73 (9.25)
Indoor unit	Input (kW)	0.28	0.28 <2.52>	0.32	0.32 <2.52>
	Current (A)	1.43	1.43 <11.45>	1.64	1.64 <11.45>
Outdoor unit	Starting current (A)	72	72	77	77
	Current (A)	8.92	9.29	10.72	10.94

* () shows the total rating. < > shows the only booster heater rating.

Indoor unit 230V 50Hz Single phase

Outdoor unit 400V 50Hz 3 phases

Model	Indoor unit	PLH-P5AAH.UK		PLH-P6AAH.UK	
	Outdoor unit	PUH-P5YGA		PUH-P6YGA	
Mode		Cool	Heat	Cool	Heat
Capacity (W)		12,700	15,900 (18,660)	14,200	16,600 (19,360)
Total Input (kW) (In + Out) (in + Out + Heater)		5.53	5.91 (8.67)	6.65	6.75 (9.51)
Indoor unit	Input (kW)	0.29	0.29 <2.76>	0.33	0.33 <2.76>
	Current (A)	1.43	1.43 <12.00>	1.64	1.64 <12.00>
Outdoor unit	Starting current (A)	76	76	81	81
	Current (A)	8.59	8.95	10.36	10.53

* () shows the total rating. < > shows the only booster heater rating.

Indoor unit 240V 50Hz Single phase

Outdoor unit 415V 50Hz 3 phases

Model	Indoor unit	PLH-P5AAH.UK		PLH-P6AAH.UK	
	Outdoor unit	PUH-P5YGA		PUH-P6YGA	
Mode		Cool	Heat	Cool	Heat
Capacity (W)		12,800	16,000 (19,000)	14,300	16,800 (19,800)
Total Input (kW) (In + Out) (in + Out + Heater)		5.55	5.93 (8.93)	6.70	6.77 (9.77)
Indoor unit	Input (kW)	0.30	0.30 <3.00>	0.34	0.34 <3.00>
	Current (A)	1.43	1.43 <12.50>	1.64	1.64 <12.50>
Outdoor unit	Starting current (A)	79	79	84	84
	Current (A)	8.39	8.74	10.17	10.28

* () shows the total rating. < > shows the only booster heater rating.

Indoor unit 220V 50Hz Single phase

Outdoor unit 220V 50Hz Single phase / 380V 50Hz 3 phases

Service Ref.	Indoor unit	PLH-P3AAH.UK PLH-P3AAH ₁ .UK				PLH-P4AAH.UK PLH-P4AAH ₁ .UK			
		PUH-P•GAA.UK							
	Outdoor unit	3V		3Y		4V		4Y	
Mode		Cool	Heat	Cool	Heat	Cool	Heat	Cool	Heat
Capacity (W)		7,600	9,100 (10,860)	7,600	9,100 (10,860)	9,500	10,400 (12,160)	9,500	10,400 (12,160)
Total Input (kW) (In + Out) (in + Out + Heater)		3.40	3.47 (5.23)	3.40	3.47 (5.23)	3.66	3.88 (5.64)	3.66	3.88 (5.64)
Indoor unit	Input (kW)	0.15	0.15 <1.76>	0.15	0.15 <1.76>	0.24	0.24 <2.18>	0.24	0.24 <2.18>
	Current (A)	0.78	0.78 <8.00>	0.78	0.78 <8.00>	1.25	1.25 <9.91>	1.25	1.25 <9.91>
Outdoor unit	Starting current (A)	85	85	43	43	91	91	44	44
	Current (A)	16.16	17.19	5.78	6.15	17.13	18.08	6.06	6.40

* () shows the total rating. < > shows the only booster heater rating.

Indoor unit 230V 50Hz Single phase

Outdoor unit 230V 50Hz Single phase / 400V 50Hz 3 phases

Service Ref.	Indoor unit	PLH-P3AAH.UK PLH-P3AAH ₁ .UK				PLH-P4AAH.UK PLH-P4AAH ₁ .UK			
		PUH-P•GAA.UK							
	Outdoor unit	3V		3Y		4V		4Y	
Mode		Cool	Heat	Cool	Heat	Cool	Heat	Cool	Heat
Capacity (W)		7,700	9,200 (11,130)	7,700	9,200 (11,130)	9,600	10,500 (12,430)	9,600	10,500 (12,430)
Total Input (kW) (In + Out) (in + Out + Heater)		3.42	3.48 (5.41)	3.42	3.48 (5.41)	3.68	3.91 (5.84)	3.68	3.91 (5.84)
Indoor unit	Input (kW)	0.16	0.16 <1.93>	0.16	0.16 <1.93>	0.25	0.25 <2.39>	0.25	0.25 <2.39>
	Current (A)	0.79	0.79 <8.39>	0.79	0.79 <8.39>	1.25	1.25 <10.39>	1.25	1.25 <10.39>
Outdoor unit	Starting current (A)	89	89	45	45	95	95	47	47
	Current (A)	15.45	16.45	5.49	5.84	16.39	17.30	5.76	6.08

* () shows the total rating. < > shows the only booster heater rating.

Indoor unit 240V 50Hz Single phase

Outdoor unit 240V 50Hz Single phase / 415V 50Hz 3 phases

Service Ref.	Indoor unit	PLH-P3AAH.UK PLH-P3AAH ₁ .UK				PLH-P4AAH.UK PLH-P4AAH ₁ .UK			
		PUH-P•GAA.UK							
	Outdoor unit	3V		3Y		4V		4Y	
Mode		Cool	Heat	Cool	Heat	Cool	Heat	Cool	Heat
Capacity (W)		7,800	9,300 (11,400)	7,800	9,300 (11,400)	9,700	10,600 (12,700)	9,700	10,600 (12,700)
Total Input (kW) (In + Out) (in + Out + Heater)		3.44	3.50 (5.60)	3.44	3.50 (5.60)	3.69	3.93 (6.03)	3.69	3.93 (6.03)
Indoor unit	Input (kW)	0.17	0.17 <2.10>	0.17	0.17 <2.10>	0.26	0.26 <2.60>	0.26	0.26 <2.60>
	Current (A)	0.81	0.81 <8.75>	0.81	0.81 <8.75>	1.25	1.25 <10.83>	1.25	1.25 <10.83>
Outdoor unit	Starting current (A)	93	93	47	47	99	99	49	49
	Current (A)	14.81	15.76	5.29	5.63	15.71	16.58	5.55	5.86

* () shows the total rating. < > shows the only booster heater rating.

Indoor unit 220V 50Hz Single phase

Outdoor unit 380V 50Hz 3 phases

Service Ref.	Indoor unit	PLH-P5AAH.UK PLH-P5AAH ₁ .UK	PLH-P6AAH.UK PLH-P6AAH ₁ .UK		
	Outdoor unit	PUH-P•GAA.UK			
		5Y	6Y		
Mode		Cool	Heat	Cool	Heat
Capacity (W)		12,600	14,700 (17,210)	14,100	16,900 (19,420)
Total Input (kW)	(In + Out) (in + Out + Heater)	4.96	5.30 (7.82)	5.85	6.33 (8.85)
Indoor unit	Input (kW)	0.28	0.28 <2.52>	0.32	0.32 <2.52>
	Current (A)	1.43	1.43 <11.45>	1.64	1.64 <11.45>
Outdoor unit	Starting current (A)	65.5	65.5	74	74
	Current (A)	8.30	8.90	9.86	10.44

* () shows the total rating. < > shows the only booster heater rating.

Indoor unit 230V 50Hz Single phase

Outdoor unit 400V 50Hz 3 phases

Service Ref.	Indoor unit	PLH-P5AAH.UK PLH-P5AAH ₁ .UK	PLH-P6AAH.UK PLH-P6AAH ₁ .UK		
	Outdoor unit	PUH-P•GAA.UK			
		5Y	6Y		
Mode		Cool	Heat	Cool	Heat
Capacity (W)		12,700	14,800 (17,560)	14,200	17,000 (19,760)
Total Input (kW)	(In + Out) (in + Out + Heater)	4.98	5.32 (8.08)	5.90	6.35 (9.11)
Indoor unit	Input (kW)	0.29	0.29 <2.76>	0.33	0.33 <2.76>
	Current (A)	1.43	1.43 <12.00>	1.64	1.64 <12.00>
Outdoor unit	Starting current (A)	65.5	65.5	74	74
	Current (A)	7.89	8.46	9.37	9.92

* () shows the total rating. < > shows the only booster heater rating.

Indoor unit 240V 50Hz Single phase

Outdoor unit 415V 50Hz 3 phases

Service Ref.	Indoor unit	PLH-P5AAH.UK PLH-P5AAH ₁ .UK	PLH-P6AAH.UK PLH-P6AAH ₁ .UK		
	Outdoor unit	PUH-P•GAA.UK			
		5Y	6Y		
Mode		Cool	Heat	Cool	Heat
Capacity (W)		12,800	14,900 (17,900)	14,300	17,100 (20,100)
Total Input (kW)	(In + Out) (in + Out + Heater)	5.00	5.34 (8.34)	5.94	6.36 (9.36)
Indoor unit	Input (kW)	0.30	0.30 <3.00>	0.34	0.34 <3.00>
	Current (A)	1.43	1.43 <12.50>	1.64	1.64 <12.50>
Outdoor unit	Starting current (A)	65.5	65.5	74	74
	Current (A)	7.60	8.15	9.03	9.56

* () shows the total rating. < > shows the only booster heater rating.

4. STANDARD OPERATION DATA

Service Ref.			PLH-P3AAH.UK		PLH-P4AAH.UK		PLH-P5AAH.UK		PLH-P6AAH.UK		
Mode			Cooling	Heating	Cooling	Heating	Cooling	Heating	Cooling	Heating	
Total	Capacity	W	7,800	9,300	9,700	10,600	12,800	16,000	14,300	16,800	
	Input	kW	3.51	3.65	3.62	3.80	5.55	5.93	6.70	6.77	
Electrical circuit	Indoor unit Service Ref.		PLH-P3AAH.UK		PLH-P4AAH.UK		PLH-P5AAH.UK		PLH-P6AAH.UK		
	Phase,Hz		1,50		1,50		1,50		1,50		
	Volts	V	240		240		240		240		
	Amperes	A	0.81		1.25		1.43		1.64		
	Outdoor unit Service Ref.		PUH-P3VGA PUH-P3YGA		PUH-P4YGA		PUH-P5YGA		PUH-P6YGA		
	Phase,Hz		1/3, 50		3, 50		3, 50		3, 50		
	Volts	V	240/415		415		415		415		
	Amperes	A	14.64/5.46	15.43/5.76	5.49	5.79	8.39	8.74	10.17	10.28	
Refrigerant circuit	Discharge pressure	Mpa (kgf/cm ²)	2.30 (23.4)	2.38 (24.3)	1.98 (20.2)	2.12 (21.6)	2.27 (23.2)	2.59 (26.4)	2.27 (23.2)	2.36 (24.1)	
	Suction pressure	Mpa (kgf/cm ²)	0.47 (4.8)	0.39 (4.0)	0.54 (5.5)	0.42 (4.3)	0.46 (4.7)	0.41 (4.21)	0.45 (4.6)	0.41 (4.2)	
	Discharge temperature	°C	81.0	88.0	71.0	7.5	78.6	86.6	80.6	83.5	
	Condensing temperature	°C	44.0	45.0	42.0	47.0	41.0	44.0	45.0	46.0	
	Suction temperature	°C	4.8	0	7.5	0.6	4.4	4.2	2.4	-1.0	
	Ref. pipe length	m	5	5	5	5	5	5	5	5	
Indoor side	Intake air temperature	D.B.	°C	27	20	27	20	27	20	27	20
		W.B.	°C	19	15	19	15	19	15	19	15
	Discharge air temperature	D.B.	°C	13.4	45.1	14.0	40.1	12.3	49.3	11.3	50.7
Outdoor side	Intake air temperature	D.B.	°C	35	7	35	7	35	7	35	7
		W.B.	°C	24	6	24	6	24	6	24	6
SHF			0.74	—	0.78	—	0.72	—	0.69	—	
BF			0.13	—	0.12	—	0.10	—	0.09	—	

The unit of pressure has been changed to Mpa based on international SI system.
The conversion factor is : 1(Mpa)=10.2(kgf/cm²)



Service Ref.			PLH-P3AAH.UK PLH-P3AAH ₁ .UK	PLH-P4AAH.UK PLH-P4AAH ₁ .UK	PLH-P5AAH.UK PLH-P5AAH ₁ .UK	PLH-P6AAH.UK PLH-P6AAH ₁ .UK					
Mode			Cooling	Heating	Cooling	Heating	Cooling	Heating	Cooling	Heating	
Total	Capacity	W	7,800	9,300	9,700	10,600	12,800	14,900	14,300	17,100	
	Input	kW	3.44	3.50	3.69	3.93	5.00	5.34	5.94	6.36	
Electrical circuit	Indoor unit Service Ref.		PLH-P3AAH.UK PLH-P3AAH ₁ .UK	PLH-P4AAH.UK PLH-P4AAH ₁ .UK	PLH-P5AAH.UK PLH-P5AAH ₁ .UK	PLH-P6AAH.UK PLH-P6AAH ₁ .UK					
	Phase,Hz		1,50		1,50		1,50		1,50		
	Volts	V	240		240		240		240		
	Amperes	A	0.81		1.25		1.43		1.64		
	Outdoor unit Service Ref.		PUH-P3VGAA.UK PUH-P3YGAA.UK	PUH-P4VGAA.UK PUH-P4YGAA.UK	PUH-P5YGAA.UK	PUH-P6YGAA.UK					
	Phase,Hz		1/3, 50		1/3, 50		3, 50		3, 50		
	Volts	V	240/415		240/415		415		415		
	Amperes	A	14.81/5.29	15.76/5.63	15.71/5.55	16.58/5.86	7.60	8.15	9.03	9.56	
Refrigerant circuit	Discharge pressure	Mpa (kgf/cm ²)	2.30 (23.4)	2.38 (24.3)	1.98 (20.2)	2.12 (21.6)	2.27 (23.2)	2.59 (26.4)	2.27 (23.2)	2.36 (24.1)	
	Suction pressure	Mpa (kgf/cm ²)	0.47 (4.8)	0.39 (4.0)	0.54 (5.5)	0.42 (4.3)	0.46 (4.7)	0.41 (4.21)	0.45 (4.6)	0.41 (4.2)	
	Discharge temperature	°C	81.0	88.0	71.0	7.5	78.6	86.6	80.6	83.5	
	Condensing temperature	°C	44.0	45.0	42.0	47.0	41.0	44.0	45.0	46.0	
	Suction temperature	°C	4.8	0	7.5	0.6	4.4	4.2	2.4	-1.0	
	Ref. pipe length	m	5	5	5	5	5	5	5	5	
Indoor side	Intake air temperature	D.B.	°C	27	20	27	20	27	20	27	20
		W.B.	°C	19	15	19	15	19	15	19	15
	Discharge air temperature	D.B.	°C	13.4	45.1	14.0	40.1	12.3	47.3	11.3	51.2
Outdoor side	Intake air temperature	D.B.	°C	35	7	35	7	35	7	35	7
		W.B.	°C	24	6	24	6	24	6	24	6
SHF			0.74	—	0.78	—	0.72	—	0.69	—	
BF			0.13	—	0.12	—	0.10	—	0.09	—	

The unit of pressure has been changed to Mpa based on international SI system.
The conversion factor is : 1(Mpa)=10.2(kgf/cm²)

5. OUTLET AIR SPEED AND COVERAGE RANGE

Service Ref.		PLH-P3AAH.UK PLH-P3AAH ₁ .UK	PLH-P4AAH.UK PLH-P4AAH ₁ .UK	PLH-P5AAH.UK PLH-P5AAH ₁ .UK	PLH-P6AAH.UK PLH-P6AAH ₁ .UK
Air flow	m ³ /min	20	28	30	30
Air speed	m/sec.	4.0	4.9	5.2	6.6
Coverage range	m	5.7	7.4	7.9	8.9

※ The air coverage range is the value up to the position where the air speed is 0.25m/sec.
When air is blown out horizontally from the unit at the Hi notch position.
The coverage range should be used only as a general guideline since it varies according to the size of the room and the furniture inside the room.

6. NOISE CRITERION CURVES

PLH-P3AAH.UK
PLH-P3AAH₁.UK

NOTCH	SPL(dB)	LINE
Hi	34	○—○
Mi1	32	△—△
Mi2	30	●—●
Lo	28	▲—▲

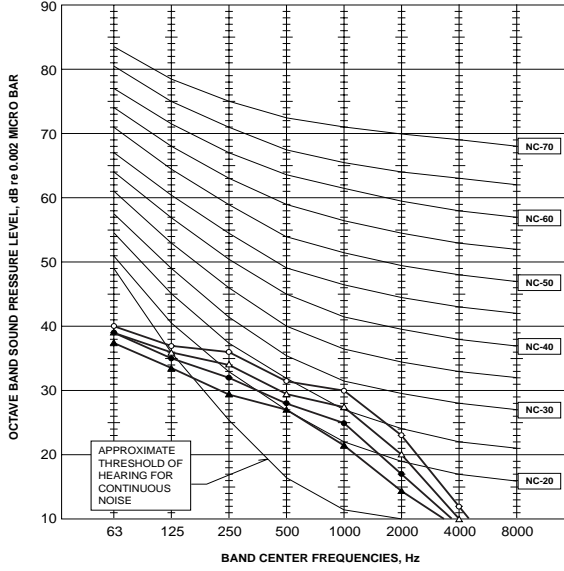

PLH-P4AAH.UK
PLH-P4AAH₁.UK

NOTCH	SPL(dB)	LINE
Hi	41	○—○
Mi1	39	△—△
Mi2	36	●—●
Lo	33	▲—▲

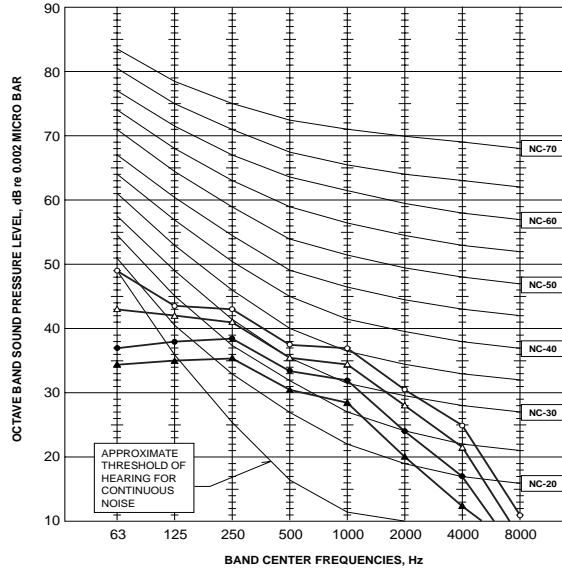

PLH-P5AAH.UK
PLH-P5AAH₁.UK

NOTCH	SPL(dB)	LINE
Hi	43	○—○
Mi1	41	△—△
Mi2	38	●—●
Lo	35	▲—▲

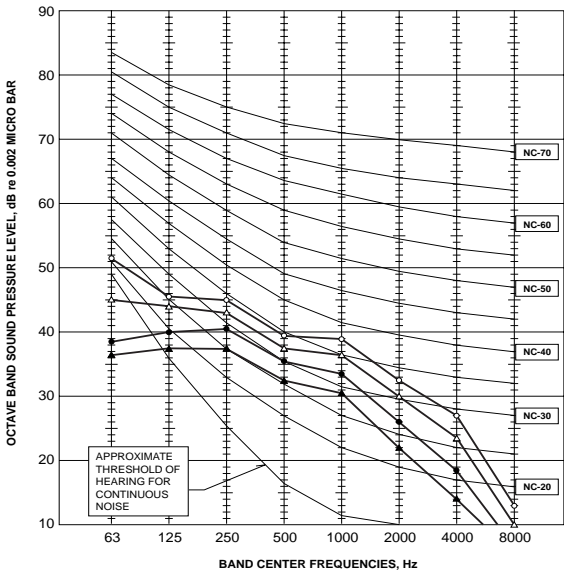

PLH-P6AAH.UK
PLH-P6AAH₁.UK

NOTCH	SPL(dB)	LINE
Hi	45	○—○
Mi1	43	△—△
Mi2	40	●—●
Lo	37	▲—▲

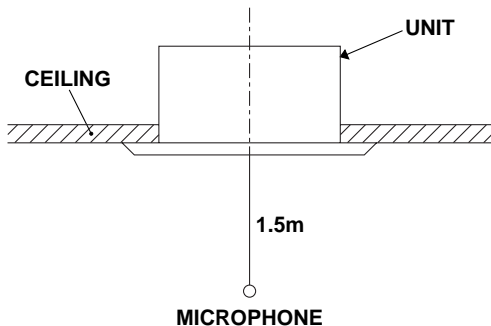
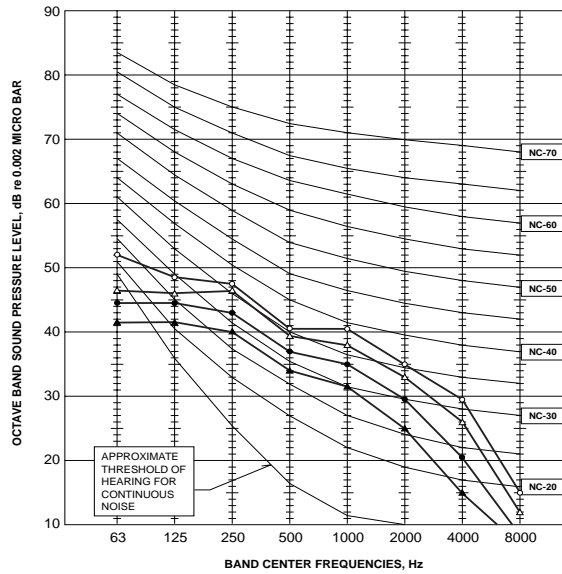

Ambient temperature 27°C

Test conditions are based on JIS Z8731

7

OUTLINES AND DIMENSIONS

PLH-P3AAH.UK, PLH-P4AAH.UK, PLH-P5AAH.UK, PLH-P6AAH.UK
 PLH-P3AAH₁.UK, PLH-P4AAH₁.UK, PLH-P5AAH₁.UK, PLH-P6AAH₁.UK

Unit: mm

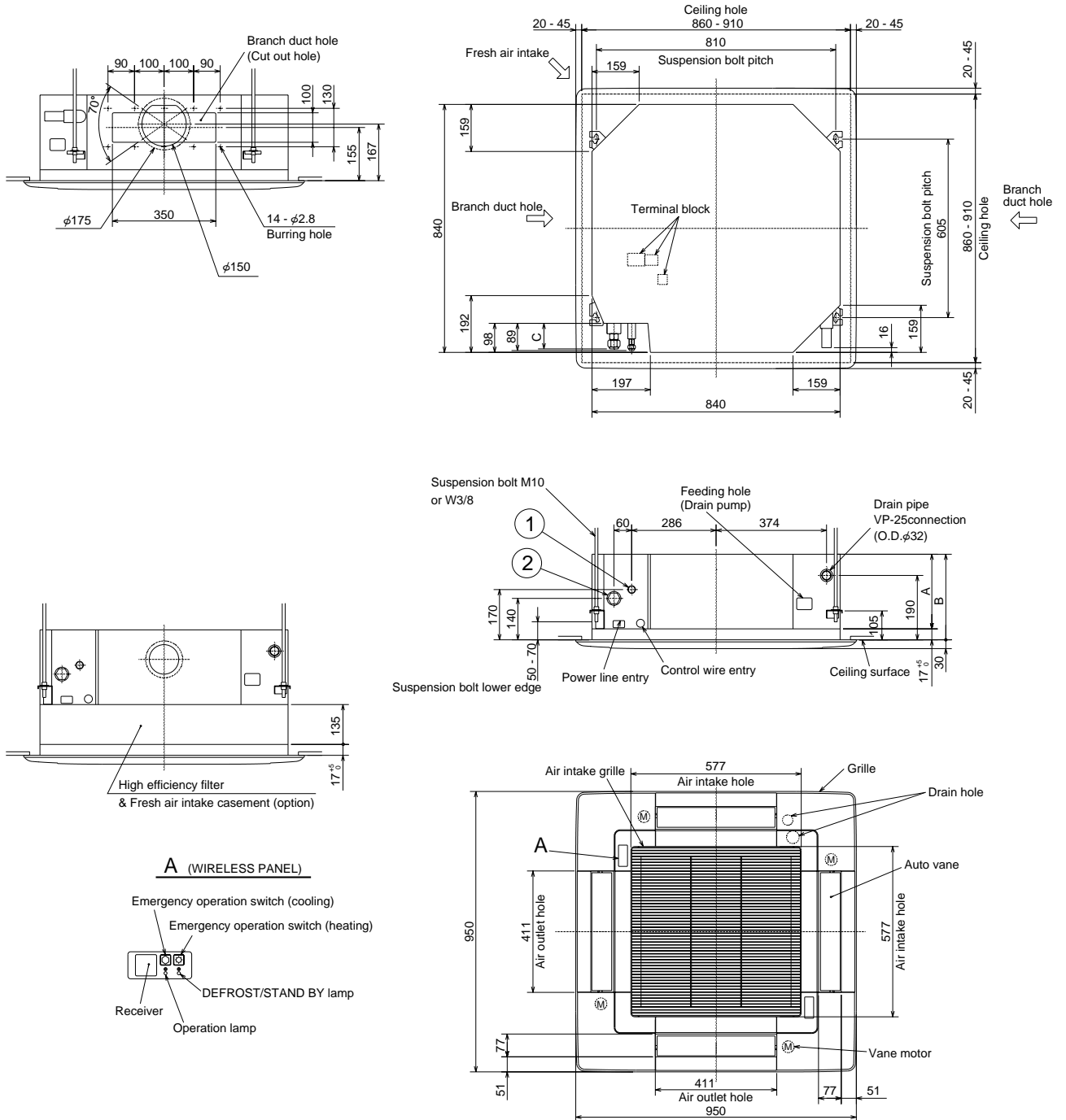

Models	①	②	A	B	C
PLH-P3AAH.UK PLH-P3AAH ₁ .UK	Refrigerant pipe (9.52mm dia.) flared connection 3/8F	Refrigerant pipe (15.88mm dia.) flared connection 5/8F	241	258	80
PLH-P4/P5/P6AAH.UK PLH-P4/P5/P6AAH ₁ .UK	Refrigerant pipe (9.52mm dia.) flared connection 3/8F	Refrigerant pipe (19.05mm dia.) flared connection 3/4F	281	298	84

PLH-P3AAH.UK, PLH-P4AAH.UK, PLH-P5AAH.UK, PLH-P6AAH.UK
 PLH-P3AAH₁.UK, PLH-P4AAH₁.UK, PLH-P5AAH₁.UK, PLH-P6AAH₁.UK

SYMBOL	NAME	SYMBOL	NAME	SYMBOL	NAME
P.B	INDOOR POWER BOARD	MV	VANE MOTOR	W.B	WIRELESS REMOTE CONTROLLER BOARD
F1	FUSE(4A)	DP	DRAIN-UP MACHINE	RU	RECEIVING UNIT
ZNR	VARIATOR	DS	DRAIN SENSOR	BZ	BUZZER
I.B	INDOOR CONTROLLER BOARD	H2	DEW PREVENTION HEATER	LED1	LED(RUN INDICATOR)
CN2L	CONNECTOR(LOSSNAY)	TB2	TERMINAL BLOCK(HEATER)	LED2	LED(HOT ADJUST)
CN32	CONNECTOR(REMOTE SWITCH)	TB4	TERMINAL BLOCK(INDOOR/OUTDOOR CONNECTING LINE)	SW1	SWITCH(HEATING ON/OFF)
CN41	CONNECTOR(HA TERMINAL-A)	TB5	TERMINAL BLOCK(REMOTE CONTROLLER TRANSMISSION LINE)	SW2	SWITCH(COOLING ON/OFF)
SW1	JUMPER WIRE(MODEL SELECTION)	TH1	ROOM TEMP.THERMISTOR (0°C/15kΩ,25°C/5.4kΩ DETECT)	HEATER	
SW2	JUMPER WIRE(CAPACITY CORD)	TH2	PIPE TEMP.THERMISTOR/LIQUID (0°C/15kΩ,25°C/5.4kΩ DETECT)	FS1	THERMAL FUSE(72°C,16A)
SWE	SWITCH(EMERGENCY OPERATION)	TH5	COND./EVA.TEMP.THERMISTOR (0°C/15kΩ,25°C/5.4kΩ DETECT)	FS2	THERMAL FUSE(104°C,16A)
X1	RELAY(DRAIN PUMP)	R.B	REMOTE CONTROLLER BOARD	H1	HEATER
X4	RELAY(FAN MOTOR)	CN2	CONNECTOR(PROGRAM TIMER)	26H	HEATER THERMAL SWITCH
FC	FAN PHASE CONTROL	TB6	TERMINAL BLOCK(REMOTE CONTROLLER TRANSMISSION LINE)	88H	HEATER CONTACTOR
LED1	POWER SUPPLY(I.B)				
LED2	POWER SUPPLY(R.B)				
LED3	TRANSMISSION(INDOOR-OUTDOOR)				
C	CAPACITOR(FAN MOTOR)				
MF	FAN MOTOR				

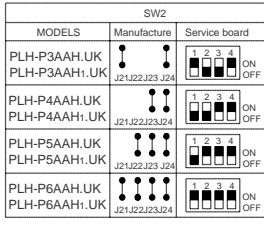
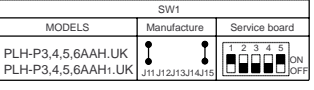
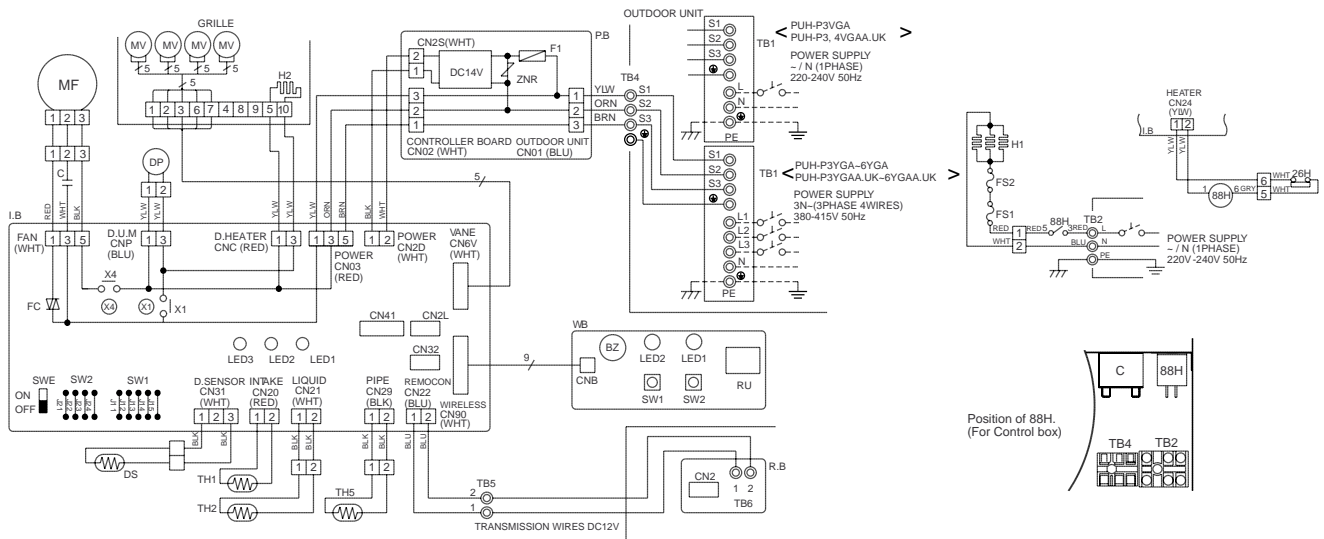

Please set the voltage using the remote controller. For the setting method, please refer to the indoor unit Installation Manual.

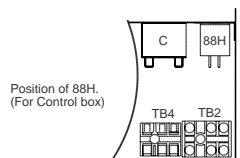

- NOTE:**
- Since the outdoor side electric wiring may change be sure to check the outdoor unit electric wiring for servicing.
 - Indoor and outdoor connecting wires are made with polarities, make wiring matching terminal numbers (S1, S2, S3).
 - Make sure that the main power supply of the booster heater is independent.
 - Symbols used in wiring diagram above are,
 - : Terminal , □ : Connector.

PLH-P3AAH.UK / PUH-P3VGA, PUH-P3YGA

Unit : mm(inch)

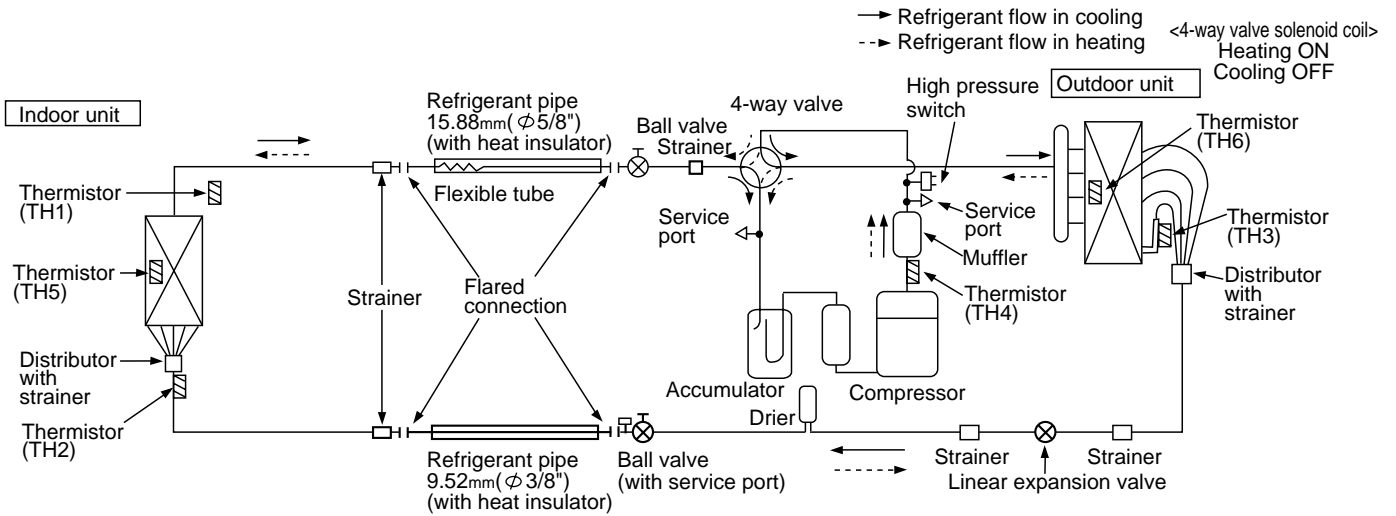

PLH-P4AAH.UK / PUH-P4YGA

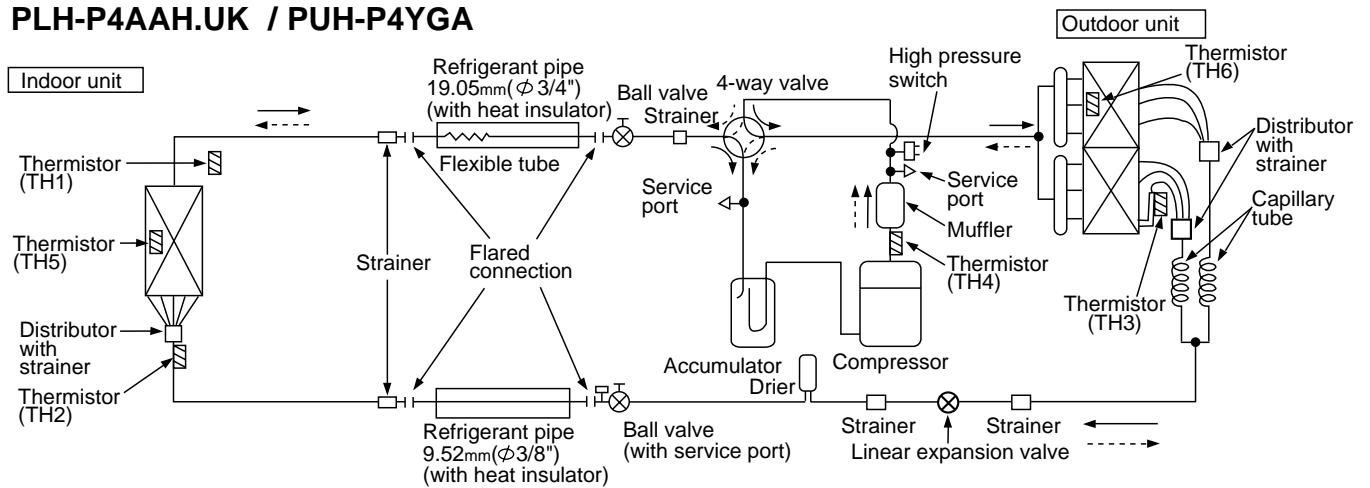

PLH-P5AAH.UK / PUH-P5YGA

PLH-P6AAH.UK / PUH-P6YGA

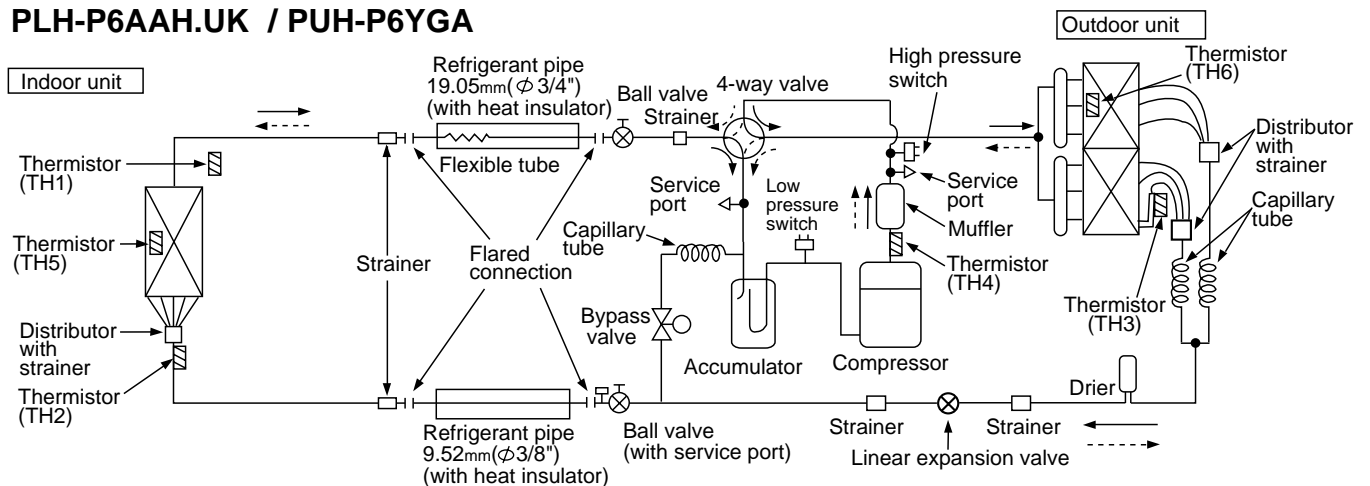

PLH-P3AAH.UK, PLH-P3AAH₁.UK / PUH-P3VGAA.UK, PUH-P3YGAA.UK

Unit : mm(inch)

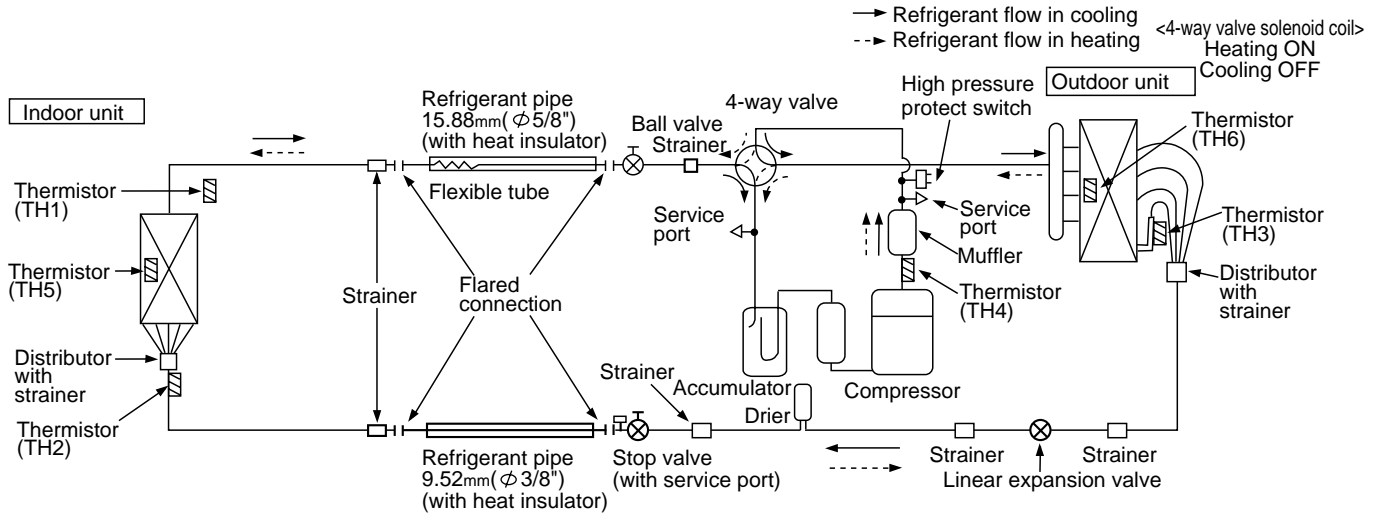

PLH-P4AAH.UK, PLH-P4AAH₁.UK / PUH-P4VGAA.UK, PUH-P4YGAA.UK

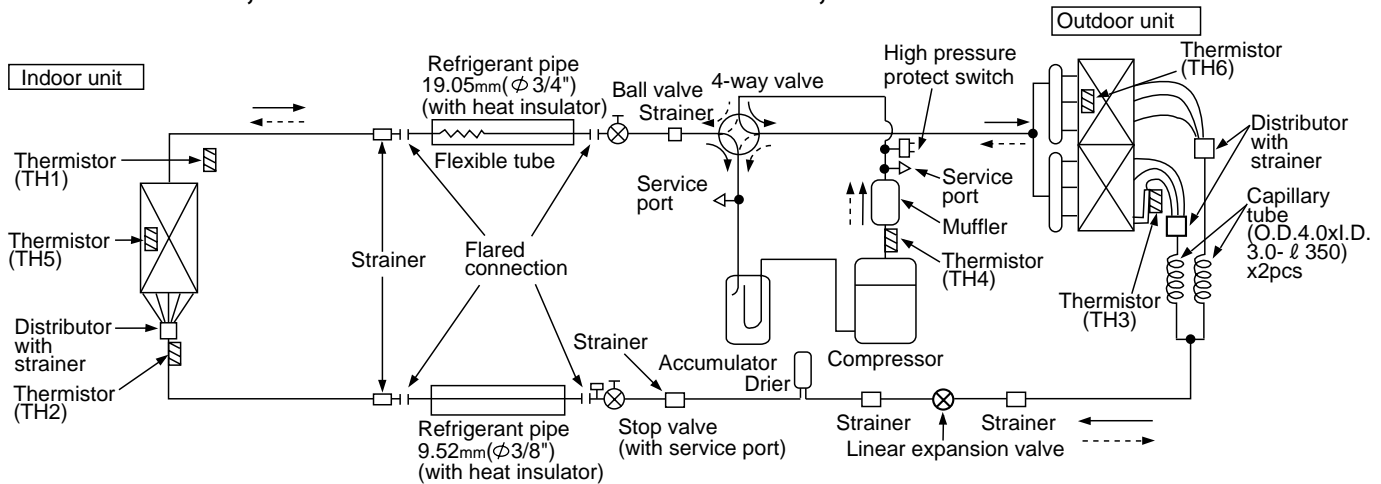

PLH-P5AAH.UK, PLH-P5AAH₁.UK / PUH-P5YGAA.UK

PLH-P6AAH.UK, PLH-P6AAH₁.UK / PUH-P6YGAA.UK

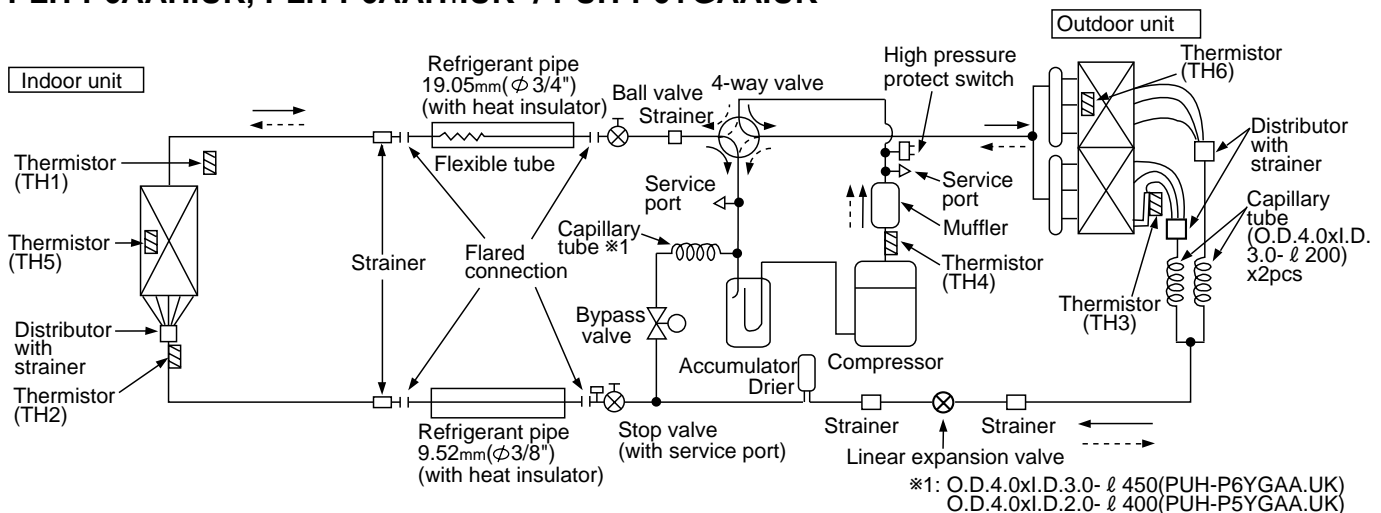

HOW TO CHECK THE PARTS

PLH-P3AAH.UK, PLH-P4AAH.UK, PLH-P5AAH.UK, PLH-P6AAH.UK
 PLH-P3AAH₁.UK, PLH-P4AAH₁.UK, PLH-P5AAH₁.UK, PLH-P6AAH₁.UK

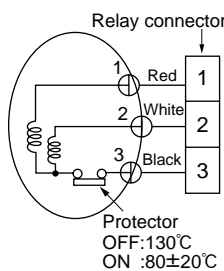
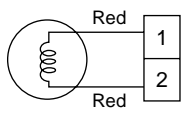
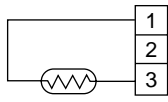
Parts name	Check points								
Room temperature thermistor (TH1) Pipe temperature thermistor (TH2) Condenser/Evaporator temperature thermistor (TH5)	Disconnect the connector then measure the resistance using a tester. (Surrounding temperature 10°C ~30°C) <table border="1" style="margin-left: 20px;"> <tr> <td>Normal</td> <td>Abnormal</td> <td rowspan="2" style="vertical-align: middle;">(Refer to the thermistor)</td> </tr> <tr> <td>4.3kΩ~9.6kΩ</td> <td>Open or short</td> </tr> </table>	Normal	Abnormal	(Refer to the thermistor)	4.3kΩ~9.6kΩ	Open or short			
Normal	Abnormal	(Refer to the thermistor)							
4.3kΩ~9.6kΩ	Open or short								
Vane motor	Measure the resistance between the terminals using a tester. (Surrounding temperature 20°C) <table border="1" style="margin-left: 20px;"> <tr> <td>Normal</td> <td>Abnormal</td> </tr> <tr> <td>15kΩ</td> <td>Open or short</td> </tr> </table>	Normal	Abnormal	15kΩ	Open or short				
Normal	Abnormal								
15kΩ	Open or short								
Fan motor 	Measure the resistance between the terminals using a tester. (Surrounding temperature 20°C) <table border="1" style="margin-left: 20px;"> <tr> <td>Motor terminal or Relay connector</td> <td>Normal</td> <td>Abnormal</td> </tr> <tr> <td>Red-Black</td> <td>87.2Ω</td> <td rowspan="2">Open or short</td> </tr> <tr> <td>White-Black</td> <td>104.1Ω</td> </tr> </table>	Motor terminal or Relay connector	Normal	Abnormal	Red-Black	87.2Ω	Open or short	White-Black	104.1Ω
Motor terminal or Relay connector	Normal	Abnormal							
Red-Black	87.2Ω	Open or short							
White-Black	104.1Ω								
Drain pump 	Measure the resistance between the terminals using a tester. (Surrounding temperature 20°C) <table border="1" style="margin-left: 20px;"> <tr> <td>Normal</td> <td>Abnormal</td> </tr> <tr> <td>290Ω</td> <td>Open or short</td> </tr> </table>	Normal	Abnormal	290Ω	Open or short				
Normal	Abnormal								
290Ω	Open or short								
Drain sensor 	Measure the resistance between the terminals using a tester. Measure the resistance after 3 minutes have passed since the power supply was intercepted. (Surrounding temperature 0°C ~60°C) <table border="1" style="margin-left: 20px;"> <tr> <td>Normal</td> <td>Abnormal</td> <td rowspan="2" style="vertical-align: middle;">(Refer to the thermistor)</td> </tr> <tr> <td>0.6kΩ~6.0kΩ</td> <td>Open or short</td> </tr> </table>	Normal	Abnormal	(Refer to the thermistor)	0.6kΩ~6.0kΩ	Open or short			
Normal	Abnormal	(Refer to the thermistor)							
0.6kΩ~6.0kΩ	Open or short								

<Thermistor Characteristic graph>

Thermistor for lower temperature

Room temperature thermistor (TH1)
 Pipe temperature thermistor (TH2)
 Condenser/evaporator temperature thermistor (TH5)

Thermistor $R_0=15k \pm 3\%$

Fixed number of $B=3480k \pm 2\%$

$$R_t = 15 \exp \left\{ 3480 \left(\frac{1}{273+t} - \frac{1}{273} \right) \right\}$$

0°C	15k
10°C	9.6k
20°C	6.3k
25°C	5.2k
30°C	4.3k
40°C	3.0k

Thermistor for drain sensor

Thermistor $R_0=6.0k \pm 5\%$

Fixed number of $B=3390k \pm 2\%$

$$R_t = 6 \exp \left\{ 3390 \left(\frac{1}{273+t} - \frac{1}{273} \right) \right\}$$

0°C	6.0k
10°C	3.9k
20°C	2.6k
25°C	2.2k
30°C	1.8k
40°C	1.3k

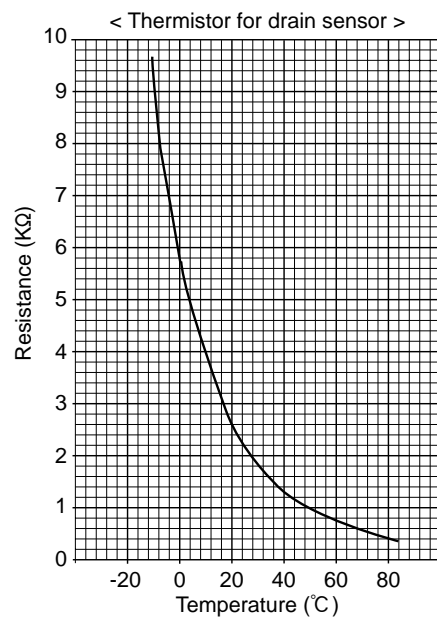
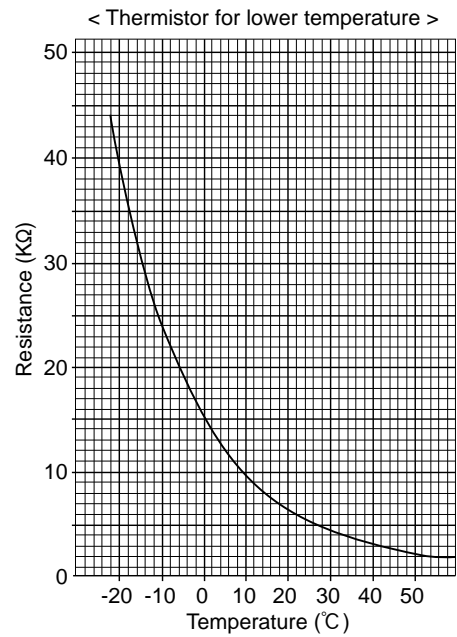

PLH-P3AAH.UK, PLH-P3AAH1.UK

Be careful on removing heavy parts.

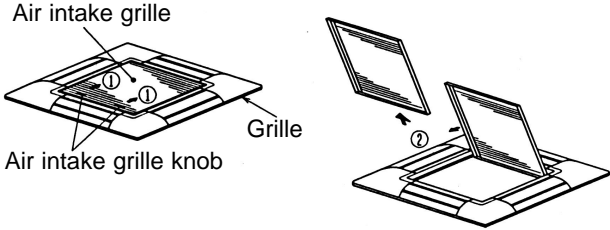
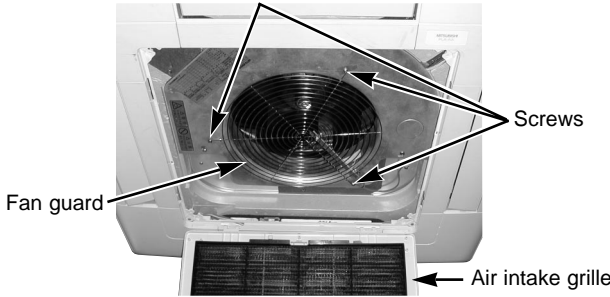
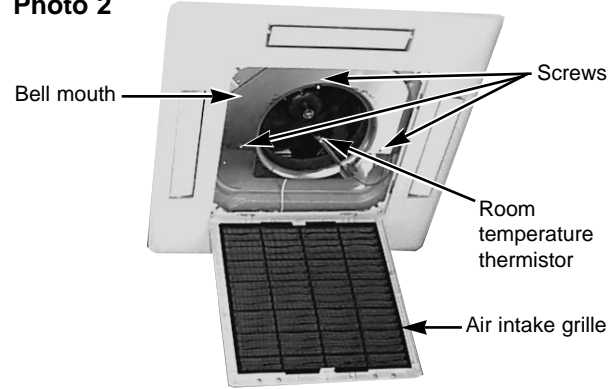
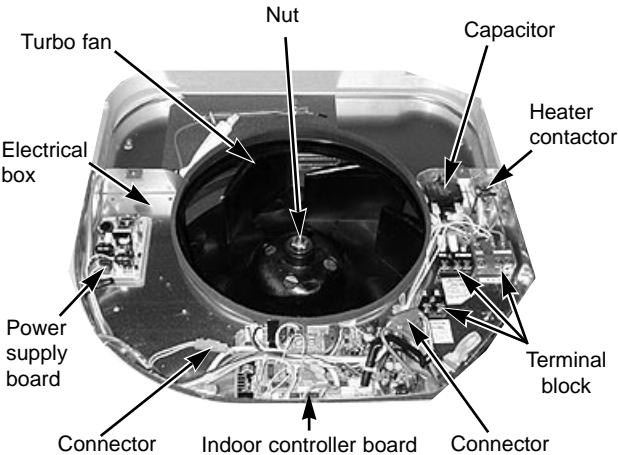
OPERATING PROCEDURE	PHOTOS & ILLUSTRATIONS
<p>1. Removing the air intake grille</p> <ol style="list-style-type: none"> (1) Slide the knob of air intake grille toward the arrow ① to open the air intake grille. (2) Remove drop prevention hook from the panel. (3) Slide the shaft in the hinge to the direction of the arrow ② and remove the air intake grille. 	<p>Figure 1</p>  <p>Air intake grille Air intake grille knob Grille</p>
<p>2. Removing the fan guard</p> <ol style="list-style-type: none"> (1) Open the air intake grille. (2) Remove the 3 screws of fan guard. 	<p>Photo 1</p>  <p>Fan guard Screws Air intake grille</p>
<p>3. Removing the room temperature thermistor</p> <ol style="list-style-type: none"> (1) Remove the fan guard. (See photo 1) (2) Remove the screw in the room temperature thermistor holder to remove the holder and the room temperature thermistor. (3) Remove the 1 screw from the bell mouth, and unscrew the other 2 screws (fix to the oval hole which has a different diameter) to remove the bell mouth. (4) Hold the holder claw, and remove the room temperature thermistor and holder. (5) Disconnect the connector (red) from the indoor control board. 	<p>Photo 2</p>  <p>Bell mouth Screws Room temperature thermistor Air intake grille</p>
<p>4. Removing the electrical box</p> <ol style="list-style-type: none"> (1) Remove the fan guard. (See photo 1) (2) Disconnect the lead wire of the vane motor from the clamp, and disconnect the white connector (8P). (3) Remove the room temperature thermistor with the holder. (4) Remove the bell mouth. (See photo 2) (5) Disconnect the relay connector in the electrical box. Red (3P) for ran motor power supply White (2P) for pipe temperature detecting thermistor Blue (2P) for drain pump White (3P) for drain sensor Green (6P) for auxiliary heater (6) Remove the 3 screws of the electrical box and loosen the other 2 screws to remove the box. <p><Electrical parts in the electrical box> Indoor controller board Power supply board Terminal block Capacitor Heater contactor</p>	<p>Photo 3</p>  <p>Turbo fan Nut Capacitor Heater contactor Terminal block Indoor controller board Power supply board Connector Electrical box Connector</p>



OPERATING PROCEDURE

PHOTOS & ILLUSTRATIONS

5. Remove the fan motor

- (1) Remove the fan guard.(See photo 1)
- (2) Remove the bell mouth.(See photo 2)
- (3) Remove the electrical box.(See photo 3)
- (4) Remove the turbo fan nut.
- (5) Pull out the turbo fan.
- (6) Disconnect the connector of the fan motor lead wire.
- (7) Remove the 4 nuts of the fan motor.

Photo 4

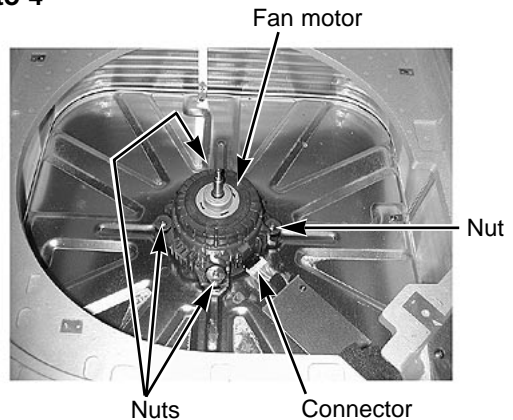

6. Removing the pipe temperature thermistor and condenser evaporator temperature thermistor

- (1) Remove the fan guard.(See photo 1)
- (2) Remove the bell mouth.(See photo 2)
- (3) Remove the electrical box.(See photo 3)
- (4) Remove the turbo fan.
- (5) Remove the screw of the service panel.
- (6) Remove the service panel.
- (7) Remove the pipe temperature thermistor which is inserted into the holder installed to the thin copper pipe.
- (8) Disconnect the 2-pin white connector.

Photo 5

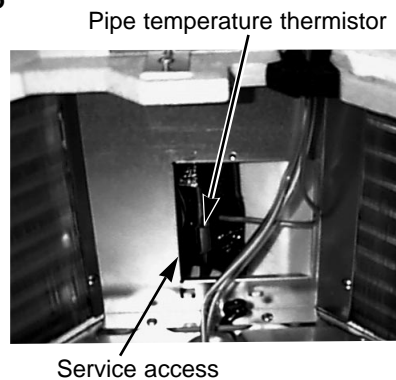

7. Removing the panel

- (1) Remove the air intake grille.(See figure 1)

Corner panel (See figure 2)

- (1) Remove the corner screw.
- (2) Slide the corner panel to the direction of the arrow③, and remove the corner panel.

Panel (See photo 6)

- (1) Disconnect the connector that connects with the unit.
- (2) Remove the 2 screws from the panel and loosen another 2 screws, which fix to the oval holes, have different diameters.
- (3) Rotate the panel a little to remove the panel.

Figure 2

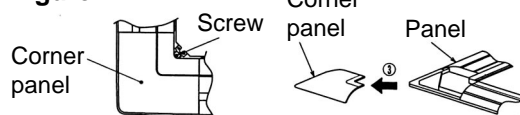
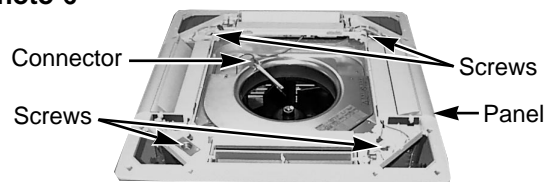

Photo 6



8. Removing the drain pan

- (1) Remove the panel. (See photo 6)
- (2) Remove the drain plug (Larger one), drain the remaining water in the drain pan.
- (3) Remove the corner cover. (2 screws)
- (4) Remove the bell mouth (See photo 2)
- (5) Remove the electrical box. (See photo 3)
- (6) Remove the lead wire holder. (1 screw)
- (7) Remove the 4 screws and pull out the drain pan.
 - * Pull out the left and right of the pan gradually.
 - Be careful not to crack or damage the pan.

Photo 7

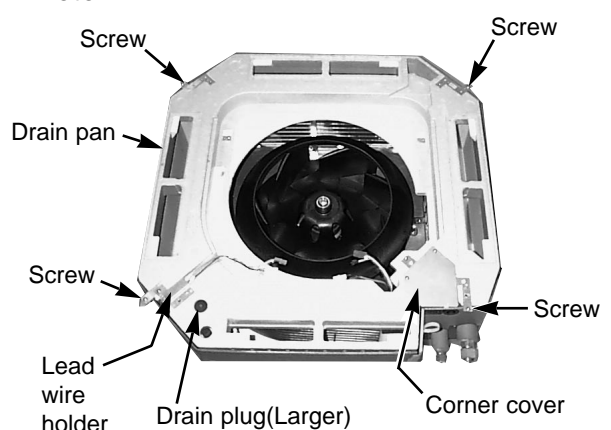



OPERATING PROCEDURE

PHOTOS & ILLUSTRATIONS

9. Removing the drain pump and drain sensor

- (1) Remove the panel. (See photo 6)
- (2) Remove the fan guard. (See photo 1)
- (3) Remove the bell mouth. (See photo 2)
- (4) Remove the electrical box. (See photo 3)
- (5) Remove the drain pan. (See photo 7)
- (6) Remove the 3 screws of the drain pump.
- (7) Cut the drain hose band, pull out the drain hose from the drain pump.
- (8) Pull out the drain pump.
- (9) Remove the drain sensor and the holder.

Photo 8

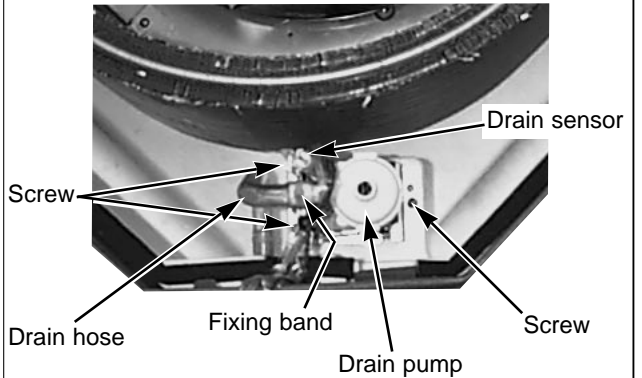

10. Removing the heat exchanger

- (1) Remove the panel. (See photo 6)
- (2) Remove the fan guard. (See photo 1)
- (3) Remove the bell mouth. (See photo 2)
- (4) Remove the electrical box. (See photo 3)
- (5) Remove the drain pan. (See photo 7)
- (6) Remove the turbo fan. (See photo 4)
- (7) Remove the 3 screws of the piping cover, and pull out piping cover.
- (8) Remove the 4 screws of the outer wall cover, and pull out the outer wall cover.
- (9) Remove the screw of the coil support.
- (10) Remove the 2 screws of the coil.
- (11) Pull out the heat exchanger.

Photo 9

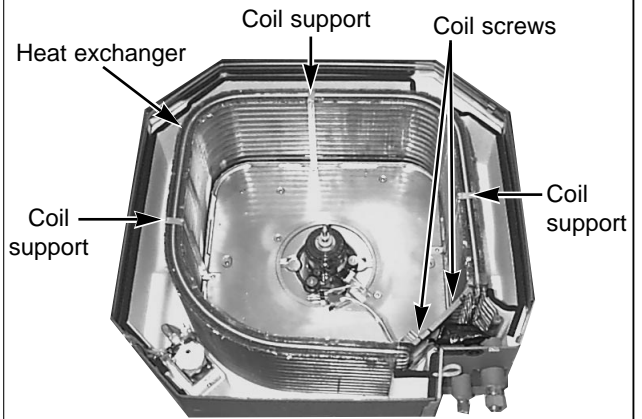
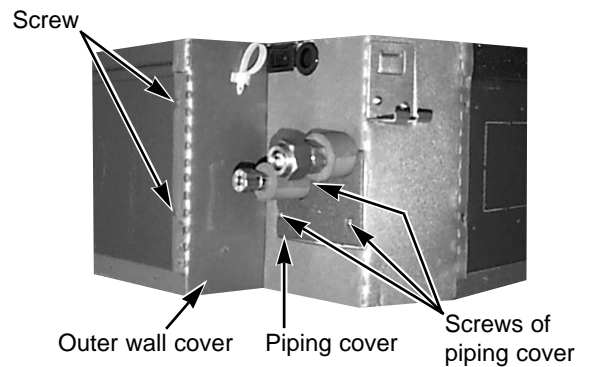
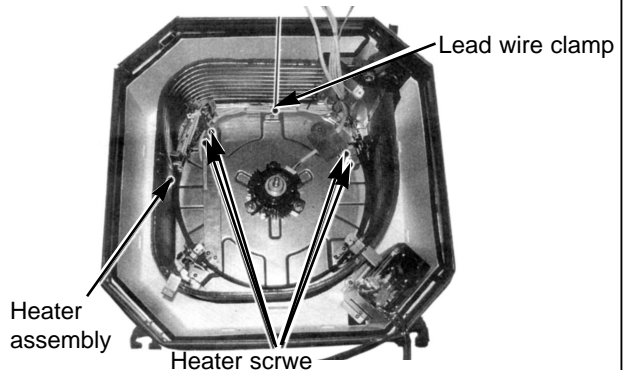

Photo 10



11. Removing the heater

- (1) Remove the panel. (See photo 6)
- (2) Remove the electrical box. (See photo 3)
- (3) Remove the bell mouth. (See photo 2)
- (4) Remove the drain pan. (See photo 7)
- (5) Remove the turbo fan. (See photo 4)
- (6) Remove the 5 screws of the heater assembly.
- (7) Remove the clamp (1 screw) securing the lead wire.
- (8) Pull the heater assembly out.



PLH-P3AAH.UK, PLH-P4AAH.UK, PLH-P5AAH.UK, PLH-P6AAH.UK
 PLH-P3AAH₁.UK, PLH-P4AAH₁.UK, PLH-P5AAH₁.UK, PLH-P6AAH₁.UK

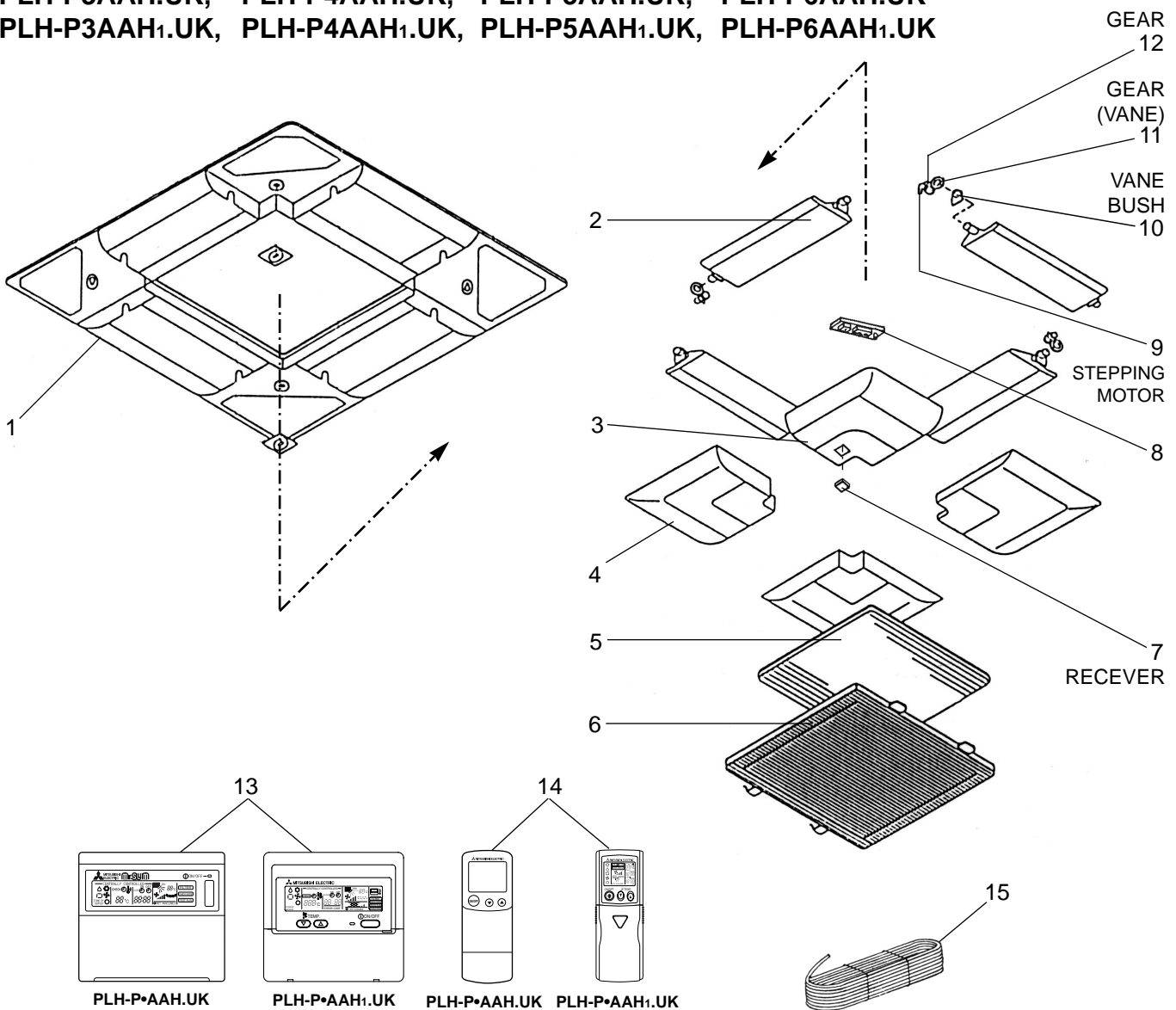

No.	Parts No.	Parts Name	Specification	Q'ty / set				Remarks (Drawing No.)	Wiring Diagram Symbol	Recom- mended Q'ty	Price	
				PLH -P3/4/5/6							Unit	Amount
				AAH.UK		AAH ₁ .UK						
WIRED	WIRELESS	WIRED	WIRELESS									
1	S70 E10 003	AIR OUTLET GRILLE		1	1	1	1					
2	S70 E01 002	VANE ASSY		4	4	4	4					
3	S70 E01 638	CORNER PANEL		1	2	1	2					
4	S70 E00 638	CORNER PANEL		3	2	3	2					
5	S70 E00 500	L.L FILTER-A		1	1	1	1					
6	S70 E00 691	GRILLE ASSY		1	1	1	1					
7	S70 24K 658	RECEVER				1	1	RU				
8	S70 E00 317	WIRELESS ADAPTER			1		1	W.B				
9	S70 E00 223	STEPPING MOTOR		4	4	4	4	MV				
10	S70 E00 063	VANE BUSH		8	8	8	8					
11	S70 E00 040	GEAR (VANE)		4	4	4	4					
12	S70 E01 040	GEAR		4	4	4	4					
13	S70 E03 713	REMOTE CONTROLLER ASSY	PAR-S27A-E	1				R.B				
	S70 E13 713	REMOTE CONTROLLER ASSY	PAR-20MAA-E			1		R.B				
14	S70 E05 714	WIRELESS REMOTE CONTROLLER ASSY	PAR-SL95A-E		1							
	S70 E15 714	WIRELESS REMOTE CONTROLLER ASSY	PAR-SL97A-E				1					
15	S70 58A 246	CORD		1	1	1	1					

FUNCTIONAL PARTS
PLH-P3AAH.UK, PLH-P4AAH.UK,
PLH-P3AAH₁.UK, PLH-P4AAH₁.UK

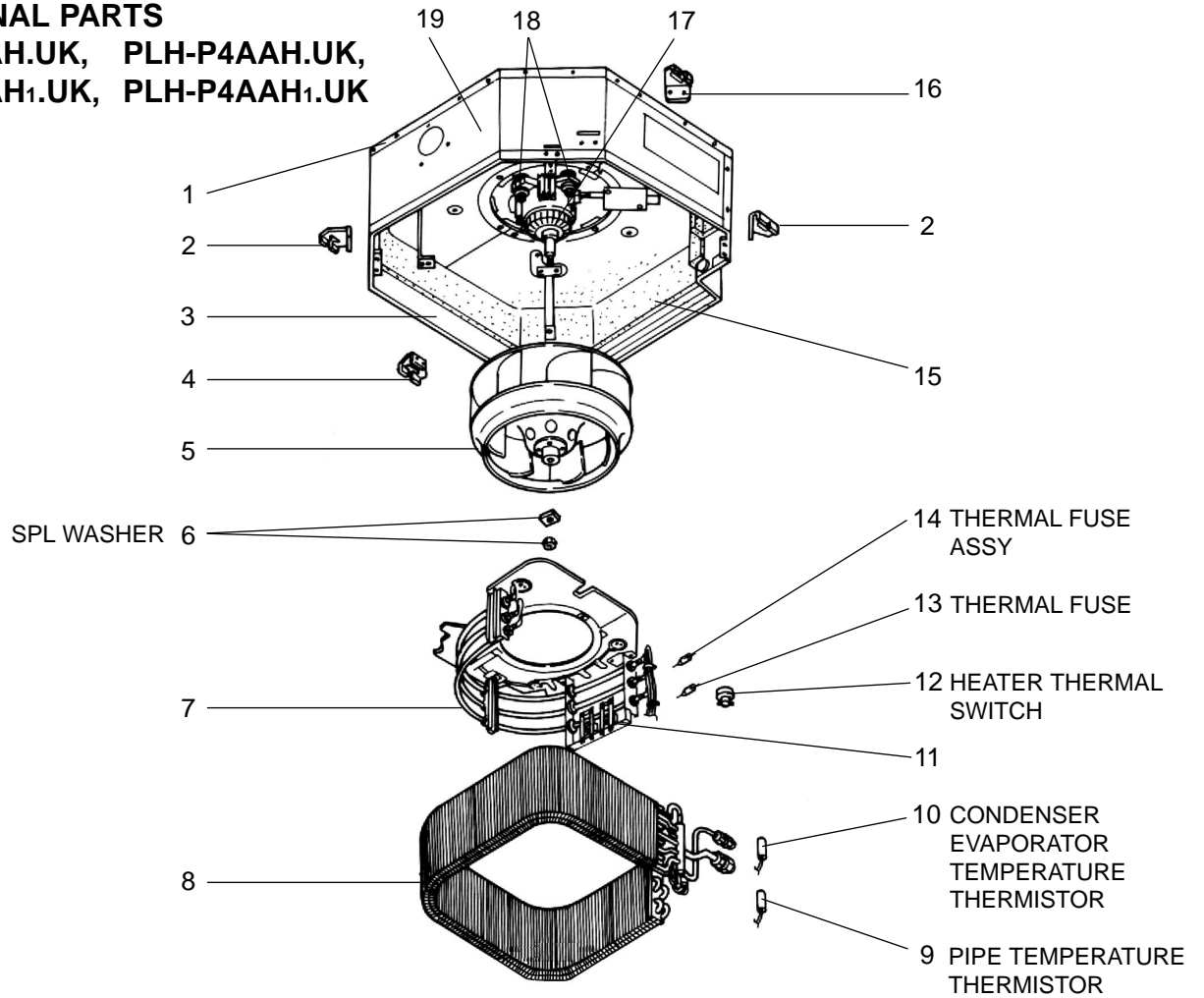

No.	Parts No.	Parts Name	Specification	Q'ty / set				Remarks (Drawing No.)	Wiring Diagram Symbol	Recom- mended Q'ty	Price	
				PLH -P3		PLH -P4					Unit	Amount
				AAH.UK	AAH ₁ .UK	AAH.UK	AAH ₁ .UK					
1	S70 003 687	BASE		1	1	1	1					
2	S70 E01 130	LEG		2	2	2	2					
3	S70 005 688	DRUM 1 ASSY		1	1							
	S70 007 688	DRUM 1 ASSY				1	1					
4	S70 E00 130	LEG		1	1	1	1					
5	S70 E00 114	TURBO FAN		1	1							
	S70 E01 114	TURBO FAN				1	1					
6	S70 08K 097	SPL WASHER		1	1	1	1					
7	S70 E07 300	HEATER ELEMENT	240V/700W	3	3				H1			
	S70 E06 300	HEATER ELEMENT	240V/867W			3	3		H1			
8	S70 E20 480	HEAT EXCHANGER		1	1							
	S70 E21 480	HEAT EXCHANGER				1	1					
9	S70 17J 202	PIPE TEMPERATURE THERMISTOR		1	1	1	1		TH2			
10	S70 E20 202	CONDENSER EVAPORATOR TEMPERATURE THERMISTOR		1	1	1	1		TH5			
11	S70 20J 303	INSULATOR		1	1	1	1					
12	S70 46K 700	HEATER THERMAL SWITCH	50°C OFF	1	1	1	1		26H			
13	S70 E02 706	THERMAL FUSE	104°C, 16A	1	1	1	1		FS2			
14	S70 E03 706	THERMAL FUSE	72°C, 16A	1	1	1	1		FS1			
15	S70 E01 659	INNER COVER		1	1							
	S70 E03 659	INNER COVER				1	1					
16	S70 E02 130	LEG		1	1	1	1					
17	S70 E06 762	FAN MOTOR	D17B6P70MS	1	1				MF			
	S70 E07 762	FAN MOTOR	D176P120MS			1	1		MF			
18	S70 A41 105	MOTOR MOUNT		4	4	4	4					
19	S70 006 688	DRUM 2 ASSY		1	1							
	S70 008 688	DRUM 2 ASSY				1	1					

FUNCTIONAL PARTS

PLH-P5AAH.UK
 PLH-P5AAH₁.UK
 PLH-P6AAH.UK
 PLH-P6AAH₁.UK

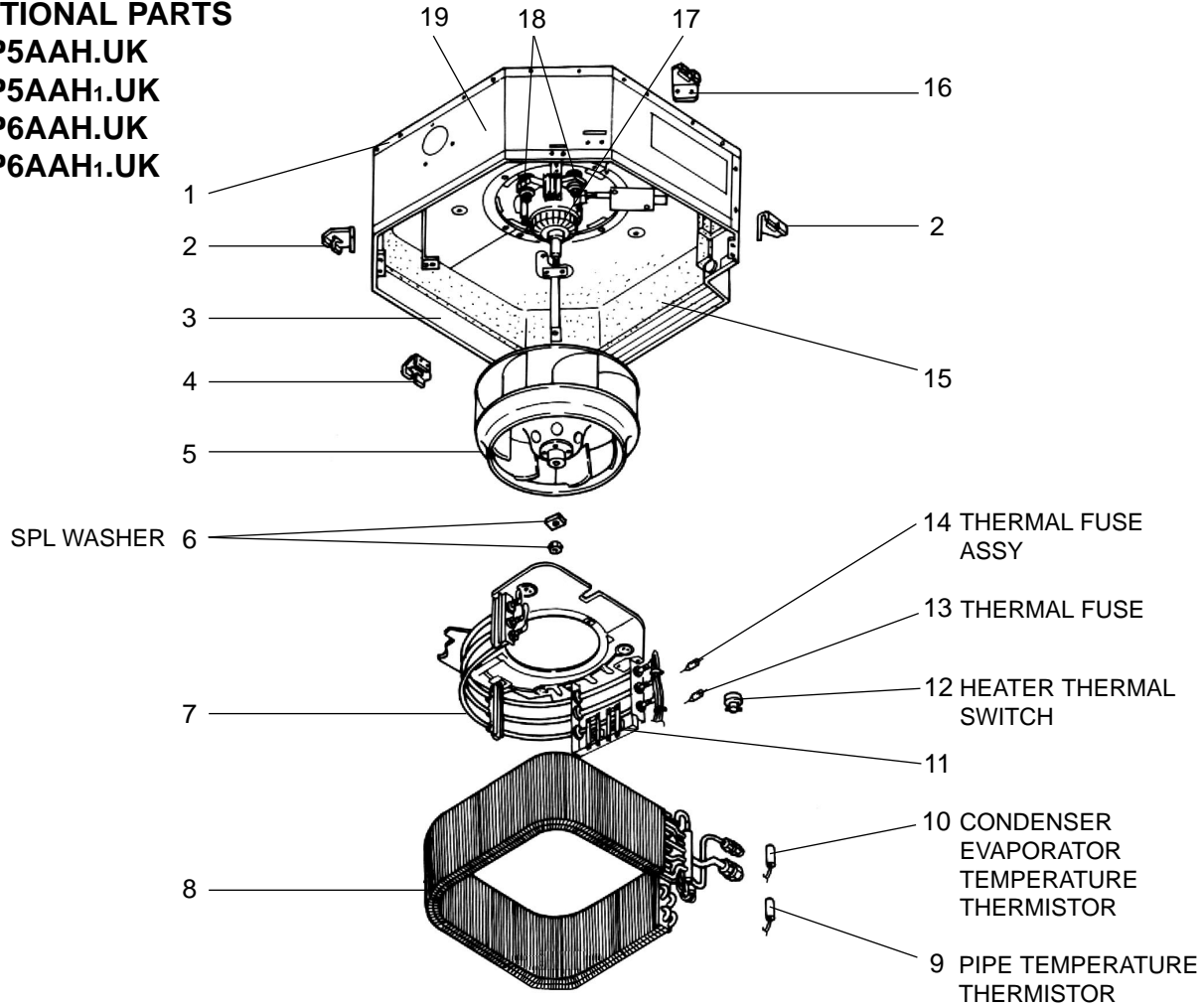

No.	Parts No.	Parts Name	Specification	Q'ty / set				Remarks (Drawing No.)	Wiring Diagram Symbol	Recom- mended Q'ty	Price	
				PLH -P5		PLH -P6					Unit	Amount
				AAH.UK	AAH ₁ .UK	AAH.UK	AAH ₁ .UK					
1	S70 003 687	BASE		1	1	1	1					
2	S70 E01 130	LEG		2	2	2	2					
3	S70 007 688	DRUM 1 ASSY		1	1	1	1					
4	S70 E00 130	LEG		1	1	1	1					
5	S70 E01 114	TURBO FAN		1	1	1	1					
6	S70 08K 097	SPL WASHER		1	1	1	1					
7	S70 E05 300	HEATER ELEMENT	240V/1000W	3	3	3	3		H1			
8	S70 E21 480	HEAT EXCHANGER		1	1							
	S70 E22 480	HEAT EXCHANGER				1	1					
9	S70 17J 202	PIPE TEMPERATURE THERMISTOR		1	1	1	1		TH2			
10	S70 E20 202	CONDENSER EVAPORATOR TEMPERATURE THERMISTOR		1	1	1	1		TH5			
11	S70 20J 303	INSULATOR		1	1	1	1					
12	S70 46K 700	HEATER THERMAL SWITCH	50°C OFF	1	1	1	1		26H			
13	S70 E02 706	THERMAL FUSE	104°C, 16A	1	1	1	1		FS2			
14	S70 E03 706	THERMAL FUSE	72°C, 16A	1	1	1	1		FS1			
15	S70 E03 659	INNER COVER		1	1	1	1					
16	S70 E02 130	LEG		1	1	1	1					
17	S70 E07 762	FAN MOTOR	D176P120MS	1	1	1	1		MF			
18	S70 A41 105	MOTOR MOUNT		4	4	4	4					
19	S70 008 688	DRUM 2 ASSY		1	1	1	1					

FUNCTIONAL PARTS

PLH-P3AAH.UK, PLH-P4AAH.UK,
PLH-P3AAH₁.UK, PLH-P4AAH₁.UK

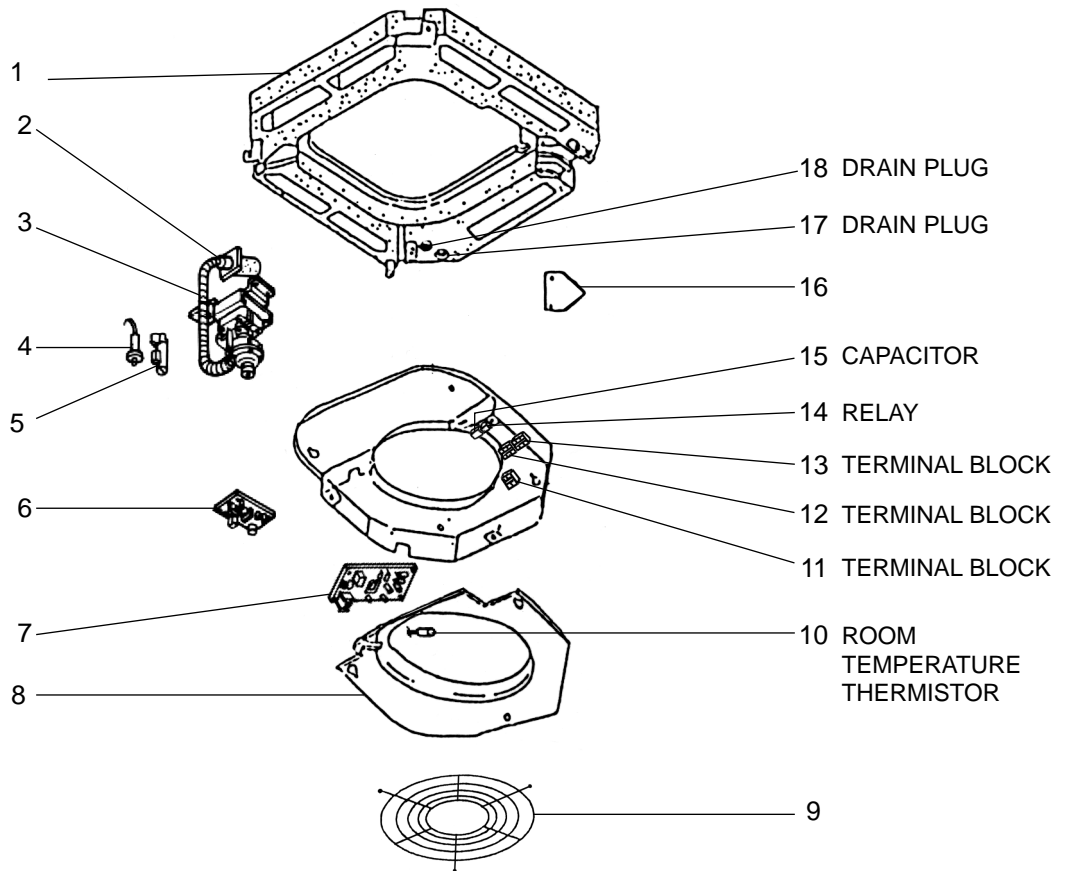

Part number that is circled is not shown in the figure.

No.	Parts No.	Parts Name	Specification	Q'ty / set				Remarks (Drawing No.)	Wiring Diagram Symbol	Recom- mended Q'ty	Price	
				PLH -P3		PLH -P4					Unit	Amount
				AAH.UK	AAH ₁ .UK	AAH.UK	AAH ₁ .UK					
1	S70 E02 529	DRAIN PAN		1	1							
	S70 E00 529	DRAIN PAN				1	1					
2	S70 29H 523	DRAIN SOCKET		1	1	1	1					
3	S70 E01 355	DRAIN PUMP		1	1	1	1		DP			
4	S70 E00 266	DRAIN SENSOR		1	1	1	1		DS			
5	S70 31K 241	DRAIN SENSOR HOLDER		1	1	1	1					
6	S70 E20 313	POWER BOARD		1	1	1	1		P.B			
7	S70 E20 310	INDOOR CONTROLLER BOARD		1	1				I.B			
	S70 E21 310	INDOOR CONTROLLER BOARD				1	1		I.B			
8	S70 003 503	CONTROL COVER ASSY		1	1	1	1					
9	S70 E10 675	FAN GUARD		1	1	1	1					
10	S70 E00 202	ROOM TEMPERATURE THERMISTOR		1	1	1	1		TH1			
11	S70 512 716	TERMINAL BLOCK	2P (1, 2)	1	1	1	1		TB5			
12	S70 517 716	TERMINAL BLOCK	3P (S1, S2, S3)	1	1	1	1		TB4			
13	S70 A14 716	TERMINAL BLOCK	2P (L, N)	1	1	1	1		TB2			
14	S70 71G 215	RELAY	JC-1A DC12V	1	1	1	1		88H			
15	S70 17T 255	CAPACITOR	3.5 μ F 440V	1	1				C			
	S70 E02 255	CAPACITOR	7.0 μ F 440V			1	1		C			
16	S70 001 663	CORNER COVER		1	1	1	1					
17	S70 A48 524	DRAIN PLUG		1	1	1	1					
18	S70 A41 524	DRAIN PLUG		1	1	1	1					
19	S70 W29 527	DRAIN HOSE		1	1	1	1					

FUNCTIONAL PARTS

PLH-P5AAH.UK, PLH-P6AAH.UK
 PLH-P5AAH₁.UK, PLH-P6AAH₁.UK

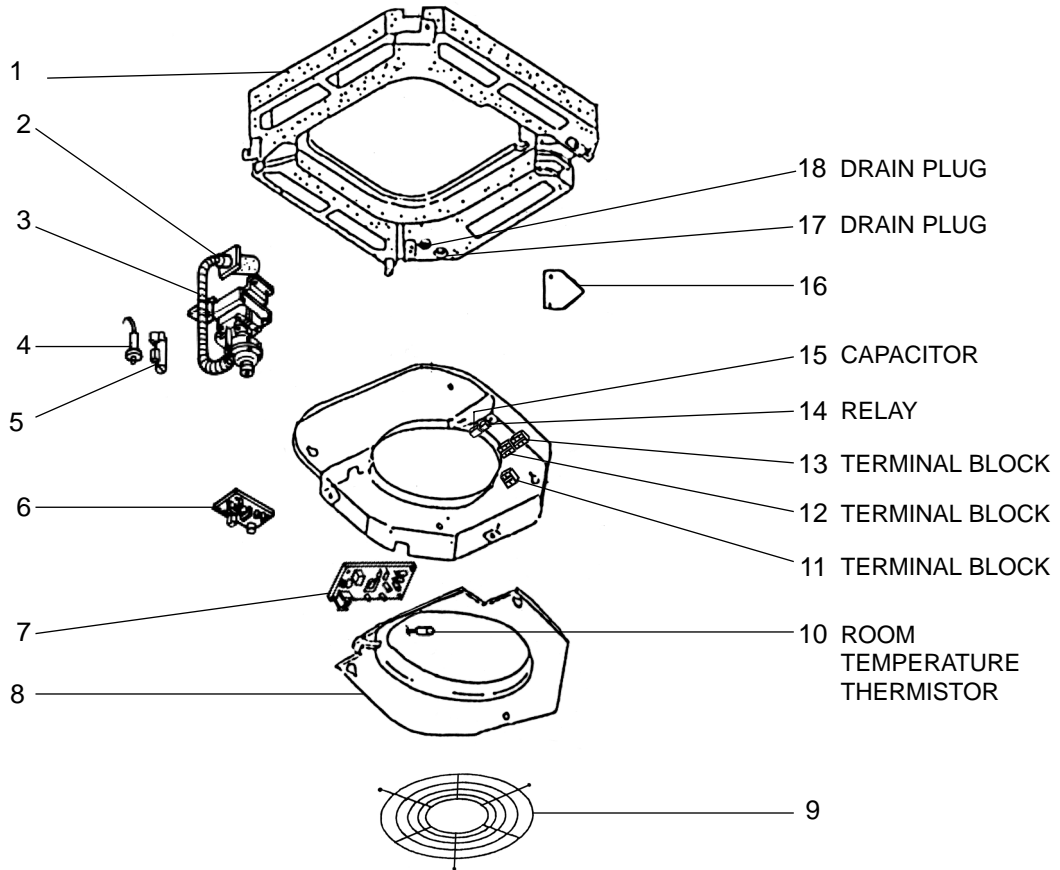

Part number that is circled is not shown in the figure.

No.	Parts No.	Parts Name	Specification	Q'ty / set				Remarks (Drawing No.)	Wiring Diagram Symbol	Recom- mended Q'ty	Price	
				PLH -P5		PLH -P6					Unit	Amount
				AAH.UK	AAH ₁ .UK	AAH.UK	AAH ₁ .UK					
1	S70 E00 529	DRAIN PAN		1	1							
	S70 E01 529	DRAIN PAN				1	1					
2	S70 29H 523	DRAIN SOCKET		1	1	1	1					
3	S70 E01 355	DRAIN PUMP		1	1	1	1	DP				
4	S70 E00 266	DRAIN SENSOR		1	1	1	1	DS				
5	S70 31K 241	DRAIN SENSOR HOLDER		1	1	1	1					
6	S70 E20 313	POWER BOARD		1	1	1	1	P.B				
7	S70 E22 310	INDOOR CONTROLLER BOARD		1	1			I.B				
	S70 E23 310	INDOOR CONTROLLER BOARD				1	1	I.B				
8	S70 003 503	CONTROL COVER ASSY		1	1	1	1					
9	S70 E10 675	FAN GUARD		1	1	1	1					
10	S70 E00 202	ROOM TEMPERATURE THERMISTOR		1	1	1	1	TH1				
11	S70 512 716	TERMINAL BLOCK	2P (1, 2)	1	1	1	1	TB5				
12	S70 517 716	TERMINAL BLOCK	3P (S1, S2, S3)	1	1	1	1	TB4				
13	S70 A14 716	TERMINAL BLOCK	2P (L, N)	1	1	1	1	TB2				
14	S70 71G 215	RELAY	JC-1A DC12V	1	1	1	1	88H				
15	S70 E02 255	CAPACITOR	7.0 μ F 440V	1	1	1	1	C				
16	S70 001 663	CORNER COVER		1	1	1	1					
17	S70 A48 524	DRAIN PLUG		1	1	1	1					
18	S70 A41 524	DRAIN PLUG		1	1	1	1					
19	S70 W29 527	DRAIN HOSE		1	1	1	1					

1. TIMER

Part No.	PAC-SC32PTA (with set back function)
Model Name	Program timer

1-1 Program timer specifications

Part name	Program timer
Parts No.	PAC-SC32PTA
Exterior dimensions (inch)	5-4/32X4-23/32X23/32 (130X120X18mm)
Installation	Wall mount
Type of clock	Quartz
Clock accuracy	±50 second / month at 25°C
Display-Time	Liquid crystal display
-Week	Liquid crystal display
-Timer setting unit	Liquid crystal display
Program cycle	24 hours
Timer setting unit	30 minutes
No. of set points	48 / day
Power rating	5V DC ±5% (Supplied by Remote Controller)

1-2 Feature of program timer

(1) Daily timer function

Daily timer can be set in 30 minutes units for up to 24 hours.
Each unit can be set for unit ON, unit OFF, or setback operation.

(2) Setback operation

Set back operation is useful for reducing running costs

e.g. At a hotel with a 24-hour system

8:00~23:00 Cooling operation with set temperature at 26°C

23:00~8:00 Setback operation with 2 degrees of setback

As shown in the chart on the right, the set temperature rises 2 degrees automatically during the setback operation. When the setback operation ends, normal operation will begin.

(3) Weekly timer function

Daily timer function can apply to each day of the week.

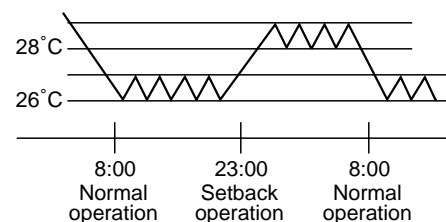

1-3. How to connect program timer

- (1) Install the program timer next to the remote controller the same way as the remote controller is installed.
- (2) Connect the program timer and the remote controller with a 5-wire cable as shown in the figure below.

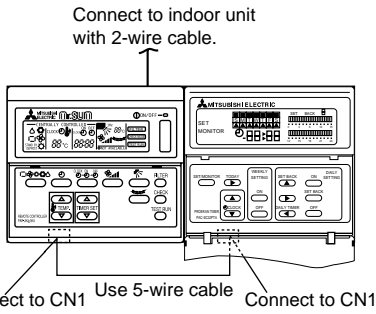

NOTE: While the program timer is connected to the remote controller, the 24hour ON/OFF timer on the remote controller will not operate.

1-4. Names and functions <PAC-SC32PTA>

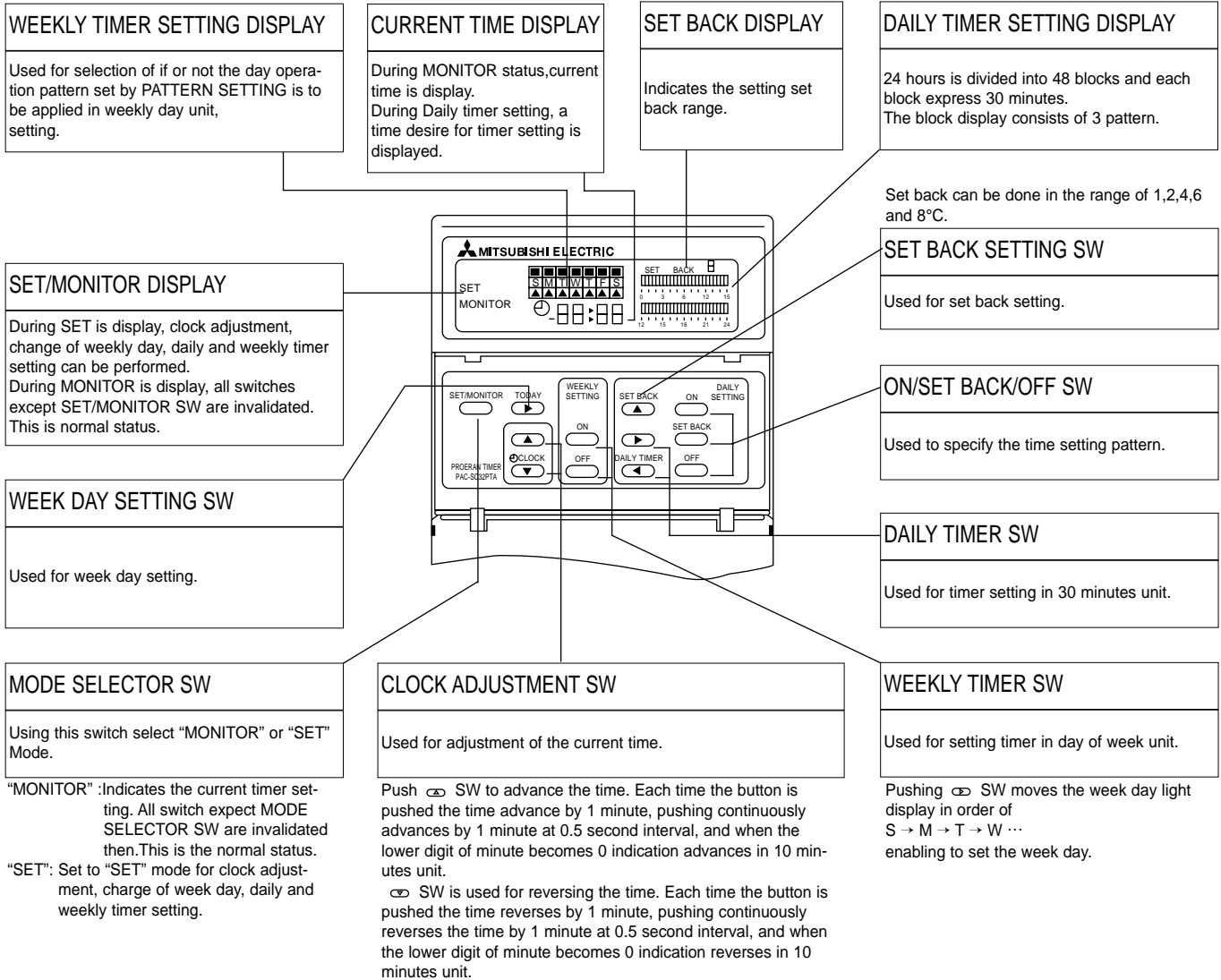



2. Multi-Functional Casement

Part No.	PAC-SG03TM-E
Applied Service Ref.	PLH-P3/4/5/6AAH.UK, PLH-P3/4/5/6AAH1.UK

3. High-Efficiency Filter Element (2. Multi-Functional Casement is needed.)

Part No.	PAC-SG01KF
Applied Service Ref.	PLH-P3/4/5/6AAH.UK, PLH-P3/4/5/6AAH1.UK

4. Grille + Wireless Remote Controller

Part No.	PLP-6AALA	PLP-6AALM
Applied Service Ref.	PLH-P3/4/5/6AAH.UK	PLH-P3/4/5/6AAH1.UK

5. Grille + Wired Remote Controller

Part No.	PLP-6AAA	PLP-6AAM
Applied Service Ref.	PLH-P3/4/5/6AAH.UK	PLH-P3/4/5/6AAH1.UK

6. Remote Sensor

Part No.	PAC-SE41TS-E
Applied Service Ref.	PLH-P3/4/5/6AAH.UK, PLH-P3/4/5/6AAH1.UK

7. Remote Operation Adapter

Part No.	PAC-SF40RM-E
Applied Service Ref.	PLH-P3/4/5/6AAH.UK, PLH-P3/4/5/6AAH1.UK

8. Remote ON/OFF Adapter

Part No.	PAC-SE55RA-E
Applied Service Ref.	PLH-P3/4/5/6AAH.UK, PLH-P3/4/5/6AAH1.UK

9. Air Outlet Shutter Plate (20set , 2pcs/set)

Part No.	PAC-SG06SP-E
Applied Service Ref.	PLH-P3/4/5/6AAH.UK, PLH-P3/4/5/6AAH1.UK

Mr. SLIM™

 **mitsubishi electric corporation**
HEAD OFFICE : MITSUBISHI DENKI BLDG., 2-2-3, MARUNOUCHI CHIYODA-KU, TOKYO100-8310, JAPAN