

OPERATION AND PARTS MANUAL



***MQ* POWER**
MODEL DCA25SSIU
WHISPERWATT™ GENERATOR
(Standard)

Revision #7 (04/18/12)

To find the latest revision of this
publication, visit our website at:
www.mqpower.com



THIS MANUAL MUST ACCOMPANY THE EQUIPMENT AT ALL TIMES.



WARNING



CALIFORNIA — Proposition 65 Warning

Engine exhaust and some of its constituents are known to the State of California to cause cancer, birth defects and other reproductive harm.

Table Of Contents 4
 Parts Ordering Procedures 5
 Rules for Safe Operation 6-9
 Towing and Transportation 10
 Trailer Safety Guidelines 11-15
 Trailer Wiring Diagram 16
 Operation Decals 17-18
 DCA-25SSIU Specifications 19
 General Information 20
 Major Components 21
 Dimensions 22
 Control Panel Descriptions 24-25
 Engine Operating Panel Descriptions 26-27
 Output Terminal Panel Descriptions 28-29
 Output Amperage Setup 30-31
 Output Voltage Setup 32-35
 Installation 36-37
 Pre Setup 38-41
 Load Application 42
 Generator Start-up Procedure 43-45
 Generator Shutdown Procedure 46
 Maintenance 47-48
 Generator Wiring Diagram 50
 Engine Wiring Diagram 51
 Engine Troubleshooting 52-53
 Generator/Engine Troubleshooting 54
 Explanation of Codes in Remarks Column 56
 Suggested Spare Parts 57

ISUZU C240 ENGINE

Cylinder Head and Cover Assembly 86-87
 Cylinder Block Assembly 88-89
 Timing Gear Assembly 90-91
 Flywheel Housing Assembly 92-93
 Oil Pan Assembly 94-95
 Oil Pump Assembly 96-97
 Crankshaft, Bridge and Flywheel Assembly 98-99
 Oil and Fuel Filter Assembly 100-101
 Oil Pipe Assembly 102-103
 Water Pump and Fan Assembly 104-105
 Intake and Exhaust Manifold Assembly 106-107
 Air Cleaner Assembly 108-109
 Engine Foot Assembly 110-111
 Injection Pump Assembly 112-113
 Electrical Parts Assembly 114-115
 Accessories 116-117
 Injection Pump Comp. Assembly 118-121
 Governor Comp. Assembly 122-127
 Feed Pump Comp. Assembly 128-129
 Auto Timer Assembly 130-131
 Nozzle Holder Comp. Assembly 132-133
 Starter Comp. Assembly 134-135
 Alternator Comp. Assembly 136-139
 Terms and Conditions of Sales 140

**MQ POWER DCA-25SSIU
AC GENERATOR**

Generator Assembly 58-59
 Control Box Assembly 60-61
 Engine & Radiator Assembly 62-67
 Engine Operating Panel Assembly 68-69
 Output Terminal Assembly 70-71
 Battery Assembly 72-73
 Muffler Assembly 74-75
 Fuel Tank Assembly 76-77
 Enclosure Assembly 78-81
 Rubber Seal Assembly 82-83
 Name Plate And Decals 84-85

NOTE

*Specification and part number
are subject to change without
notice.*

PARTS ORDERING PROCEDURES

Ordering parts has never been easier! Choose from three easy options:

Effective:
January 1st, 2006

www.multiquip.com



Order via Internet (Dealers Only):

Order parts on-line using Multiquip's SmartEquip website!

- View Parts Diagrams
- Order Parts
- Print Specification Information



If you have an MQ Account, to obtain a Username and Password, E-mail us at: parts@multiquip.com.

To obtain an MQ Account, contact your District Sales Manager for more information.

Goto www.multiquip.com and click on **Order Parts** to log in and save!

Use the **internet** and qualify for a **5% Discount** on *Standard orders* for all orders which include complete part numbers.*

Note: Discounts Are Subject To Change

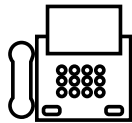

Order via Fax (Dealers Only):

All customers are welcome to order parts via Fax.

Domestic (US) Customers dial:
1-800-6-PARTS-7 (800-672-7877)

Fax your order in and qualify for a **2% Discount** on *Standard orders* for all orders which include complete part numbers.*

Note: Discounts Are Subject To Change



Order via Phone: Domestic (US) Dealers Call:
1-800-427-1244

Non-Dealer Customers:

Contact your local Multiquip Dealer for parts or call 800-427-1244 for help in locating a dealer near you.



International Customers should contact their local Multiquip Representatives for Parts Ordering information.

When ordering parts, please supply:

- | | |
|---|--|
| <input type="checkbox"/> Dealer Account Number | <input type="checkbox"/> Specify Preferred Method of Shipment: |
| <input type="checkbox"/> Dealer Name and Address | <input checked="" type="checkbox"/> UPS/Fed Ex <input checked="" type="checkbox"/> DHL |
| <input type="checkbox"/> Shipping Address (if different than billing address) | <input type="checkbox"/> Priority One <input checked="" type="checkbox"/> Truck |
| <input type="checkbox"/> Return Fax Number | <input type="checkbox"/> Ground |
| <input type="checkbox"/> Applicable Model Number | <input type="checkbox"/> Next Day |
| <input type="checkbox"/> Quantity, Part Number and Description of Each Part | <input type="checkbox"/> Second/Third Day |

NOTICE

All orders are treated as *Standard Orders* and will ship the same day if received prior to 3PM PST.

WE ACCEPT ALL MAJOR CREDIT CARDS!



CAUTION:



Failure to follow instructions in this manual may lead to serious injury or even death! This equipment is to be operated by trained and qualified personnel only! This equipment is for industrial use only.

The following safety guidelines should always be used when operating the DCA-25SSIU portable generator:

GENERAL SAFETY

- **DO NOT** operate or service this equipment before reading this entire manual.



- This equipment should not be operated by persons under 18 years of age.

- **NEVER** operate this equipment without proper protective clothing, shatterproof glasses, steel-toed boots and other protective devices required by the job.



- **NEVER** operate this equipment when not feeling well due to fatigue, illness or taking medicine.



- **NEVER** operate this equipment under the influence of drugs or alcohol.



- **NEVER** use accessories or attachments, which are not recommended by MQ Power for this equipment. Damage to the equipment and/or injury to user may result.

- Manufacturer does not assume responsibility for any accident due to equipment modifications.

- Whenever necessary, replace nameplate, operation and safety decals when they become difficult read.

- Always check the machine for loosened threads or bolts before starting.

- **NEVER** touch the hot exhaust manifold, muffler or cylinder. Allow these parts to cool before servicing engine or generator.



- **High Temperatures** – Allow the engine to cool before adding fuel or performing service and maintenance functions. Contact with *hot* components can cause serious burns.

- The engine of this generator requires an adequate free flow of cooling air. Never operate the generator in any enclosed or narrow area where free flow of the air is restricted. If the air flow is restricted it will cause serious damage to the generator or engine and may cause injury to people. The generator engine gives off DEADLY carbon monoxide gas.

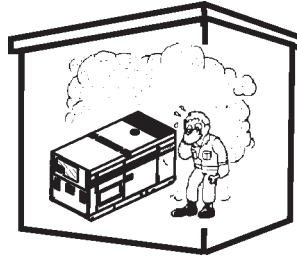

CAUTION:



- Always refuel in a well-ventilated area, away from sparks and open flames.

- Always use extreme caution when working with **flammable** liquids. When refueling, **stop the engine** and allow it to cool. **DO NOT** smoke around or near the machine. Fire or explosion could result from fuel vapors, or if fuel is spilled on a hot engine.

- **NEVER** operate the generator in an explosive atmosphere or near combustible materials. An explosion or fire could result causing severe *bodily harm or even death*.

- Topping-off to filler port is dangerous, as it tends to spill fuel.



RULES FOR SAFE OPERATION

CAUTION:

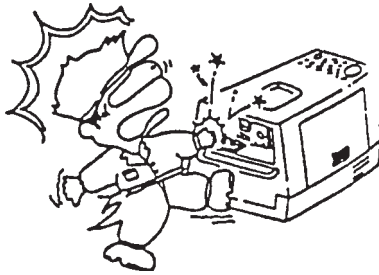

■ **NEVER** touch output terminals during operation. This is extremely dangerous. Always stop the machine when contact with the output terminals is required.

CAUTION:

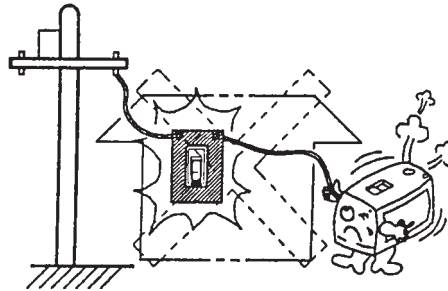

■ **Backfeed** to a utility system can cause electrocution and/or property damage. Do not connect to any building's electrical system except through an approved device or after building main switch is opened.

CAUTION:

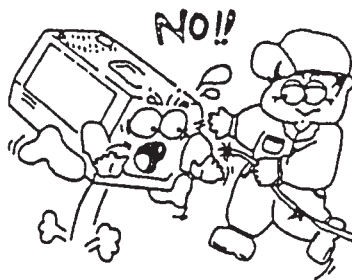

■ **Never** use damaged or worn cables when connecting power tools or equipment to the generator. Make sure power connecting cables are securely connected to the generator's output terminals, insufficient tightening of the terminal connections may cause damage to the generator and electrical shock.

CAUTION:

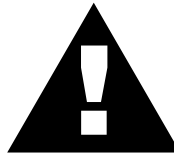

DO NOT touch or open any of the below mentioned components while the generator is running. Always allow sufficient time for the engine and generator to cool before performing maintenance.

Fluid Plugs

1. **Radiator Cap** - Removing the radiator cap while the engine is hot, will result in high pressurized, boiling water to spew out of the radiator, causing severe scalding to any persons in the general area of the generator.
2. **Coolant Drain Plug** - Removing the coolant drain plug while the engine is hot will result in hot coolant to flow out of the coolant drain plug, therefore causing severe scalding to any persons in the general area of the generator.

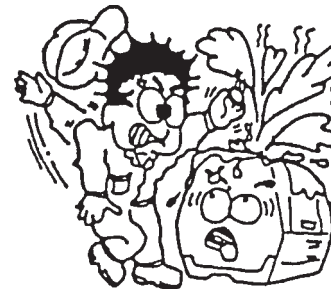

3. **Engine Oil Drain Plug** - Removing the engine oil drain plug while the engine is hot will result in hot oil to flow out of the oil drain plug, therefore causing severe scalding to any persons in the general area of the generator.

Battery

CAUTION:



Never over fill the battery with water above the upper limit.

The battery contains acids that can cause injury to the eyes and skin. To avoid eye irritation, always wear safety glasses. Use well insulated gloves when picking up the battery. Use the following guidelines when handling the battery:

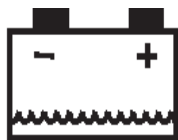

BATT. LOW LEVEL

1. **DO NOT** drop the battery. There is the possibility of risk that the battery may explode.
 2. **DO NOT** expose the battery to open flames, sparks, cigarettes etc. The battery contains combustible gases and liquids. If these gases and liquids come in contact with a flame or spark, an explosion could occur.
 3. Always keep the battery charged. If the battery is not charged a buildup of combustible gas will occur.
 4. Always keep battery charging and booster cables in good working condition. Repair or replace all worn cables.
 5. Always recharge the battery in an open air environment, to avoid risk of a dangerous concentration of combustible gases.
 6. In case the battery liquid (dilute sulfuric acid) comes in contact with **clothing or skin**, rinse skin or clothing immediately with plenty of water.
 7. In case the battery liquid (dilute sulfuric acid) comes in contact with your **eyes**, rinse eyes immediately with plenty of water, then contact the nearest doctor or hospital, and seek medical attention.
- **NEVER** Run engine without air filter. Severe engine damage may occur.
 - Always service air cleaner frequently to prevent carburetor malfunction.
 - Always disconnect the battery before performing service on the generator.
 - Always be sure the operator is familiar with proper safety precautions and operations techniques before using generator.
 - Always store equipment properly when not in use. Equipment should be stored in a clean, dry location out of the reach of children.
 - **DO NOT** leave the generator running in the manual mode unattended.
 - **DO NOT** allow unauthorized people to operate this equipment.
 - Always read, understand, and follow procedures in Operator's Manual before attempting to operate equipment.
 - Refer to the *Isuzu Engine Owner's Manual* for engine technical questions or information.

Loading and Unloading (Crane)

- Before lifting, make sure the generator's lifting hook is secure and that there is no apparent damage to the generator itself (loose screws, nuts and bolts). If any part is loose or damaged, please take corrective action before lifting.
- Always drain fuel prior to lifting.
- Always make sure crane or lifting device has been properly secured to the hook of guard frame on generator.
- **NEVER** lift the machine while the engine is running.
- Use adequate lifting cable (wire or rope) of sufficient strength.
- When lifting the generator, always use the balanced center-point suspension hook and lift straight upwards.
- **NEVER** allow any person or animal to stand underneath the machine while lifting.
- When loading the generator on a truck, be sure to use the front and back frame bars as a means to secure the generator during transport.

Transporting

- Always shutdown engine before transporting.
- Tighten fuel tank cap securely.
- Drain fuel when transporting generator over long distances or rough terrains.
- Always tie-down the generator during transportation by securing the generator.
- If generator is mounted on a trailer, make sure trailer complies with all local and state safety transportation laws. See page 10 for basic towing procedures.

Emergencies

- Always know the location of the nearest **fire extinguisher** and **first aid kit**. Know the location of the nearest telephone. Also know the phone numbers of the nearest **ambulance**, **doctor** and **fire department**.

Maintenance Safety

- **NEVER** lubricate components or attempt service on a running machine.
- Always allow the machine a proper amount of time to cool before servicing.
- Keep the machinery in proper running condition.
- Fix damage to the machine immediately and always replace broken parts.
- Dispose of hazardous waste properly. Examples of potentially hazardous waste are used motor oil, coolant, fuel, and fuel filters.
- **DO NOT** use plastic containers to dispose of hazardous waste.
- **DO NOT** pour waste, oil, coolant or fuel directly onto the ground, down a drain or into any water source.

DCA-25SSIU — TOWING RULES FOR SAFE OPERATION

Towing Safety Precautions

CAUTION :



Check with your county or state safety towing regulations department before towing your generator.

To reduce the possibility of an accident while transporting the generator on public roads, always make sure the trailer (Figure 1) that supports the generator and the towing vehicle are in good operating condition and both units are mechanically sound.

The following list of suggestions should be used when towing your generator:

- Make sure the hitch and coupling of the towing vehicle are rated equal to, or greater than the trailer "gross vehicle weight rating" (GVWR).
- **ALWAYS** inspect the hitch and coupling for wear. **NEVER** tow a trailer with defective hitches, couplings, chains etc.
- Check the tire air pressure on both towing vehicle and trailer. Also check the tire tread wear on both vehicles.
- **ALWAYS** make sure the trailer is equipped with a "Safety Chain".

- **ALWAYS** attach trailer's safety chain to bumper of towing vehicle.
- **ALWAYS** make sure the vehicle and trailer directional, backup, brake, and trailer lights are connected and working properly.
- The maximum speed unless otherwise posted for highway towing is **55 MPH**. It is not recommended for off-road towing. However, if necessary, do not exceed **15 MPH** or less depending on type of terrain to prevent damage to the axles.
- Place *chocked blocks* underneath wheel to prevent **rolling**, while parked.
- Place *support blocks* underneath the trailer's bumper to prevent **tipping**, while parked.
- Use the trailer's hand winch to adjust the height of the trailer, then insert locking pin to lock wheel stand in place, while parked.
- Avoid sudden stops and starts. This can cause skidding, or jackknifing. Smooth, gradual starts and stops will improve gas mileage.
- Avoid sharp turns to prevent rolling.
- Remove wheel stand when transporting.
- **DO NOT** transport generator with fuel in tank.

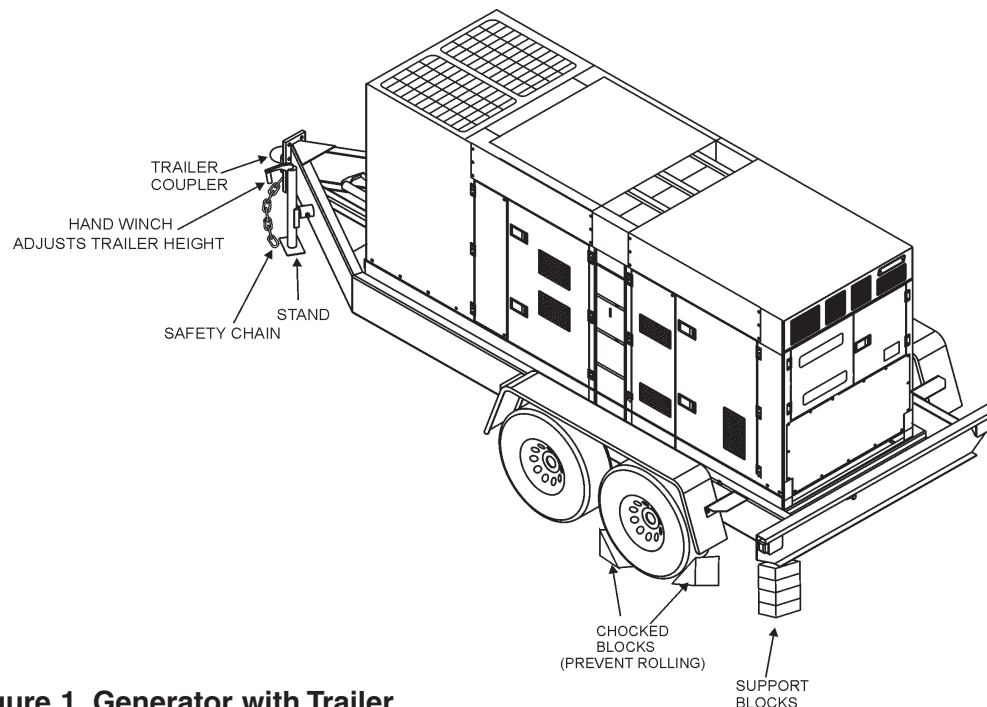

Figure 1. Generator with Trailer

CAUTION:



ALWAYS make sure the trailer is in good operating condition. Check the tires for proper inflation and wear. Also check the wheel lug nuts for proper tightness.

Explanation of Chart:

This section is intended to provide the user with trailer service and maintenance information. The service and maintenance guidelines referenced in this section apply a wide range of trailers. Remember periodic inspection of the trailer will ensure safe towing of the equipment and will prevent damage to the equipment and personal injury.

It is the purpose of this section to cover the major maintenance components of the trailer. The following trailer components will be discussed in this section:

- Tires
- Lug Nut Torquing
- Suspension
- Electrical

Use the following definitions with reading Table 1.

1. **Fuel Cell** - Provides an adequate amount of fuel for the equipment in use. Fuel cells must be empty when transporting equipment.
2. **Braking System** - System employed in stopping the trailer. Typical braking systems are electric, surge, hydraulic, hydraulic-surge and air.
3. **GVWR**- Gross Vehicle Weight Rating (GVWR), is the maximum number of pounds the trailer can carry, including the fuel cell (empty).
4. **Frame Length** - This measurement is from the ball hitch to the rear bumper (reflector).
5. **Frame Width** - This measurement is from fender to fender.
6. **Jack Stand** - Trailer support device with maximum pound requirement from the tongue of the trailer.
7. **Coupler** - Type of hitch used on the trailer for towing.
8. **Tire Size** - Indicates the diameter of the tire in inches (10,12,14, etc.), and the width in millimeters (175,185,205, etc.). The tire diameter must match the diameter of the tire rim.
9. **Tire Ply** - The tire ply (layers) number is rated in letters; 2-ply,4-ply,6-ply, etc.
10. **Wheel Hub** - The wheel hub is connected to the trailer's axle.
11. **Tire Rim** - Tires mounted on a tire rim. The tire rim must match the size of the tire.
12. **Lug Nuts** - Used to secure the wheel to the wheel hub. Always use a torque wrench to tighten down the lug nuts. See Table 4 and Figure 5 or lug nut tightening and sequence.
13. **Axle** - Indicates the maximum weight the axle can support in pounds, and the diameter of the axle expressed in inches (see Table 3). Please note that some trailers have a double axle. This will be shown as 2-6000 lbs., meaning two axles with a total weight capacity of 6000 pounds.
14. **Suspension** - Protects the trailer chassis from shocks transmitted through the wheels. Types of suspension used are leaf, Q-flex, and air ride.
15. **Electrical** - Electrical connectors (looms) are provided with the trailer so the brake lights and turn signals can be connected to the towing vehicle.
16. **Application** - Indicates which units can be employed on a particular trailer.

DCA-25SSIU — TRAILER-SPECIFICATIONS

Table 1. Specifications

MODEL	APPLICATION	FUEL CELL	BRAKE SYSTEM	GVWR	FRAME LENGTH	FRAME WIDTH	JACK STAND
TRLR-10W	SDW225, SGW250,TLW300	NO	NO	1900LBS	96"	50"	800LB. FULL TILT WHEEL
TRLR-10	DCA10, TLG12, DCA-15	NO	NO	1900LBS	96"	50"	800LB. FULL TILT WHEEL
TRLR-10XF	DCA10, TLG-12, DCA15, TLW-300	52 GAL	NO	1900LBS	96"	50"	800LB. FULL TILT WHEEL
TRLR-225W	WELDERS, DA7000SS	NO	NO	2200LBS	85"	42"	800LB. FULL TILT WHEEL
TRLR-BLW400	BLW-400	NO	ELECTRIC	2700LBS	W/MAST 154" W/O 124"	55" (78" TALL)	800LB. FULL TILT WHEEL
TRLR-50X	DCA-25	NO	NO	2700LBS	124"	55"	800LB. FULL TILT WHEEL
TRLR-50XF	DCA-25	41 GAL	NO	2700LBS	124"	55"	800LB. FULL TILT WHEEL
TRLR-70W	DCA-45, -60, 70	NO	SURGE	7000LBS	186"	77"	2000LB. FLAT PAD
TRLR-70X	DCA-45, -60, 70	OPT	SURGE	7000LBS	138"	66"	2000LB. FLAT PAD
TRLR-70XF	DCA-45, -60, 70	53 GAL	SURGE	7000LBS	138"	66"	2000LB. FLAT PAD
TRLR-100XF	DCA-100, 125	150 GAL	HYDRAULIC SURGE	7000LBS	190"	76"	2000LB. FLAT PAD
TRLR-85/125	DCA-85, 100, 125	145 GAL	HYDRAULIC	10000LBS	186"	77"	2000LB. FLAT PAD
TRLR-150XF	DCA-150, 180	200 GAL	HYDRAULIC SURGE	11160LBS	204"	84"	5000 LB. FLAT PAD
TRLR-220XF	DCA-220	250 GAL	HYDRAULIC SURGE	14000LBS	222"	83"	5000 LB. FLAT PAD
TRLR-300XF	DCA-300	250 GAL	HYDRAULIC SURGE	18000LBS	238"	83"	5000 LB. FLAT PAD
TRLR-400XF	DCA-400	350 GAL	ELECTRIC	18000LBS	238"	83"	5000 LB. FLAT PAD
TRLR-600XF	DCA-600, 800	550 GAL	AIR	30000LBS	384"	96"	5000 LB. FLAT PAD
TRLR-800SX	DCA-600, 800	550 GAL	AIR	30000LBS	384"	96"	5000 LB. FLAT PAD

DCA-25SSIU — TRAILER-SPECIFICATIONS

Table 1. Specifications (Con't)

MODEL	COUPLER	TIRES	WHEELS	AXLE	HUBS	SUSPENSION	ELECTRICAL
TRLR-10W	2" BALL CLASS 2 ADJUSTABLE	175-13C	13"X4.50"	2200# 2X2	5 LUG	3 LEAF	4 WIRE LOOM W/ 4 POLE FLAT
TRLR-10	2" BALL CLASS 2 ADJUSTABLE	175-13C	13"X4.5"	2200#2X2	5 LUG	3 LEAF	4 POLE FLAT
TRLR-10XF	2" BALL CLASS 2 ADJUSTABLE	175-13C	13"X4.5"	2200#2X2	5 LUG	3 LEAF	4 POLE FLAT
TRLR-225W	2" BALL CLASS 2 ADJUSTABLE	175-13B	13X4.5"	2200#2X2	5 LUG	Q FLEX	4 POLE FLAT
TRLR-BLW 400	2" BALL CLASS 2 ADJUSTABLE	175-13C	13 X 4.5"	2200#2X2	5 LUG	3 LEAF	4 POLE FLAT
TRLR-50X	2" BALL CLASS	B78-13LRC	13"X4.50"	3500lbs. 2-3/8"	5 LUG	4 LEAF	4 POLE RUBBER FLAT
TRLR-50XF	2" BALL CLASS	B78-13LRC	13"X4.50"	3500lbs. 2-3/8"	5 LUG	4 LEAF	4 POLE RUBBER FLAT
TRLR-70W	2" BALL CLASS 3" ADJUSTABLE	205-14C BIAS (4)	14"X5"	3500lbs. 3"	5 LUG	5 LEAF	4 POLE RUBBER FLAT
TRLR-70X	2" BALL CLASS 3" ADJUSTABLE	205-14C BIAS (4)	14"X5"	3500lbs 3"	5 LUG	5 LEAF	4 POLE RUBBER FLAT
TRLR-70XF	2" BALL CLASS 3" ADJUSTABLE	205-14C BIAS (4)	14"X5"	3500lbs. 3"	5 LUG	5 LEAF	4 POLE RUBBER FLAT
TRLR-100XF	ADJUSTABLE 2-5/6 OPT 3" EYE	205-15C BIAS (4)	14"X5.5"	3500lbs 3"	5 LUG	5 LEAF	4 WIRE LOOM
TRLR-85/125	ADJUSTABLE 2-5/6 OPT 3" EYE	ST225/75R15D RADIAL (4)	14"x6"	(2)-6000lbs	6 LUG	7 LEAF	4 WIRE LOOM
TRLR-150XF	3" BALL EYE	750-16 E BIAS (4)	16"X7"	(2)-6000lbs	8 LUG	7 LEAF	4 WIRE LOOM
TRLR-220XF	3" EYE ADJUSTABLE	ST235/85R16E RADIAL(4)	16"X7"	(2)-7000lbs	8 LUG	Q FLEX	4 WIRE LOOM
TRLR-300XF	3" EYE ADJUSTABLE	ST235/85R16E RADIAL(6)	16"X7"	(2)-6000lbs	8 LUG	Q FLEX	4 WIRE LOOM
TRLR-400XF	3" EYE ADJUSTABLE	ST235/85R16E RADIAL(6)	16"X7"	(3)-7000lbs.	8 LUG	Q FLEX	4 WIRE LOOM
TRLR-600XF	5TH WHEEL	ST215/75R17.5H RADIAL (8)	16"X7"	(3)-10000lbs	8 LUG	7 LEAF	6 WIRE LOOM
TRLR-800AR	5TH WHEEL	ST215/75R17.5H RADIAL (8)	16"X7"	(3)-10000lbs	8 LUG	AIR-RIDE	6 WIRE LOOM

Tires/Wheels/Lug Nuts

Tires and wheels are a very important and critical components of the trailer. When specifying or replacing the trailer wheels it is important the wheels, tires, and axle are properly matched.

CAUTION:



DO NOT attempt to repair or modify a wheel. DO NOT install in inner tube to correct a leak through the rim. If the rim is cracked, the air pressure in the inner tube

may cause pieces of the rim to explode (break off) with great force and cause serious eye or bodily injury.

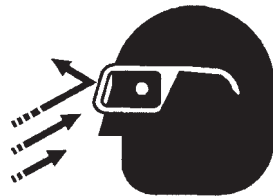

Tire Wear/Inflation

Tire inflation pressure is the most important factor in tire life. Pressure should be checked cold before operation. DO NOT bleed air from tires when they are hot. Check inflation pressure weekly during use to insure the maximum tire life and tread wear.

Table 2 (Tire Wear Troubleshooting) will help pinpoint the causes and solutions of tire wear problems.

WEAR PATTERN		CAUSE	SOLUTION
	Center Wear	Over Inflation.	Adjust pressure to particular load per tire manufacturer.
	Edge Wear	Under Inflation.	Adjust pressure to particular load per tire manufacturer.
	Side Wear	Loss of camber or overloading.	Make sure load does not exceed axle rating. Align wheels.
	Toe Wear	Incorrect toe-in.	Align wheels.
	Cupping	Out-of-balance.	Check bearing adjustment and balance tires.
	Flat Spots	Wheel lockup & tire skidding.	Avoid sudden stops when possible and adjust brakes.

Suspension

The leaf suspension springs and associated components (Figure 2) should be visually inspected every 6,000 miles for signs of excessive wear, elongation of bolt holes, and loosening of fasteners. Replace all damaged parts (suspension) immediately. Torqued suspension components as detailed in Table 3.

CAUTION:

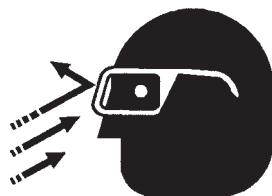

NOTE

ALWAYS wear safety glasses when removing or installing force fitted parts. Failure to comply may result in serious injury.

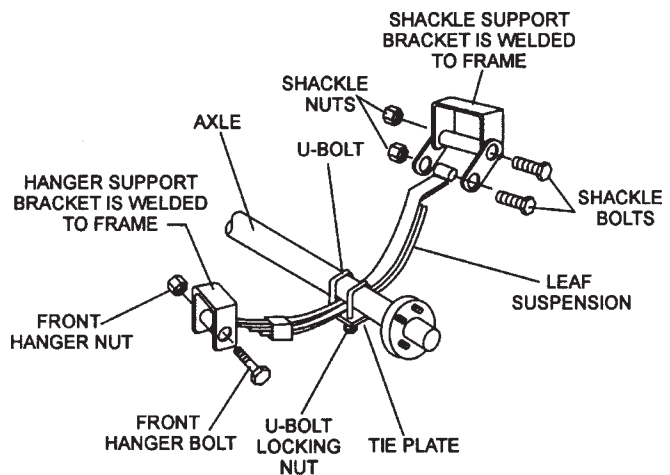

Figure 2. Major Suspension Components

Table 3. Suspension Torque Requirements

Item	Torque (Ft.-Lbs.)
3/8" U-BOLT	MIN-30 MAX-35
7/16" U-BOLT	MIN-45 MAX-60
1/2" U-BOLT	MIN-45 MAX-60
SHACKLE BOLT SPRING EYE BOLT	SNUG FIT ONLY. PARTS MUST ROTATE FREELY. LOCKING NUTS OR COTTER PINS ARE PROVIDED TO RETAIN NUT-BOLT ASSEMBLY.
SHOULDER TYPE SHACKLE BOLT	MIN-30 MAX-50

Lug Nut Torque Requirements

It is extremely important to apply and maintain proper wheel mounting torque on the trailer. Be sure to use only the fasteners matched to the cone angle of the wheel. Proper procedure for attachment of the wheels is as follows:

1. Start all wheel lug nuts by hand.
2. Torque all lug nuts in sequence. See Figure 3. **DO NOT** torque the wheel lug nuts all the way down. Tighten each lug nut in 3 separate passes as defined by Table 4.
3. After first road use, retorque all lug nuts in sequence. Check all wheel lug nuts periodically.

Table 4. Tire Torque Requirements

Wheel Size	First Pass FT-LBS	Second Pass FT-LBS	Third Pass FT-LBS
12"	20-25	35-40	50-65
13"	20-25	35-40	50-65
14"	20-25	50-60	90-120
15"	20-25	50-60	90-120
16"	20-25	50-60	90-120

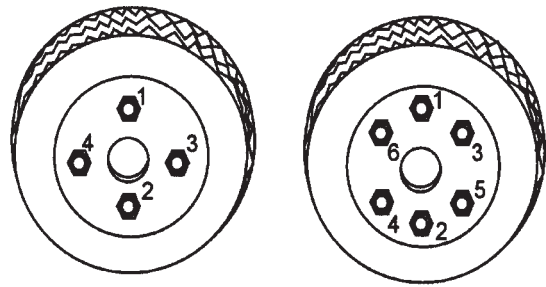

4-LUG NUTS

6-LUG NUTS

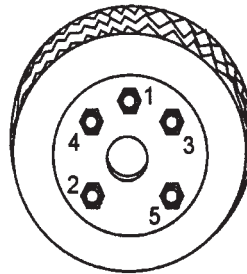

5-LUG NUTS

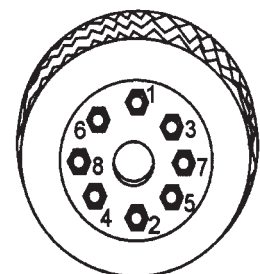

8-LUG NUTS

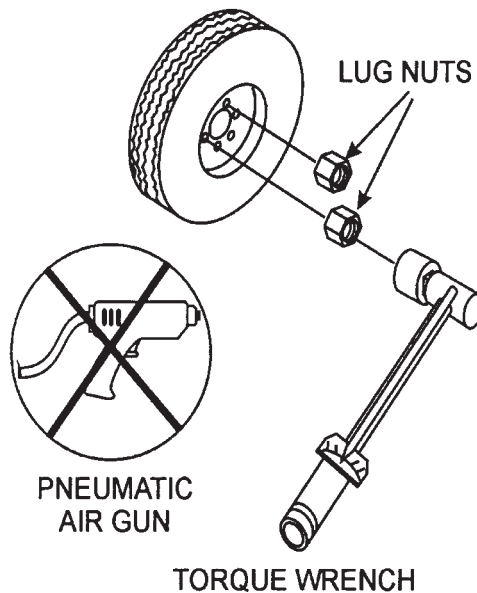
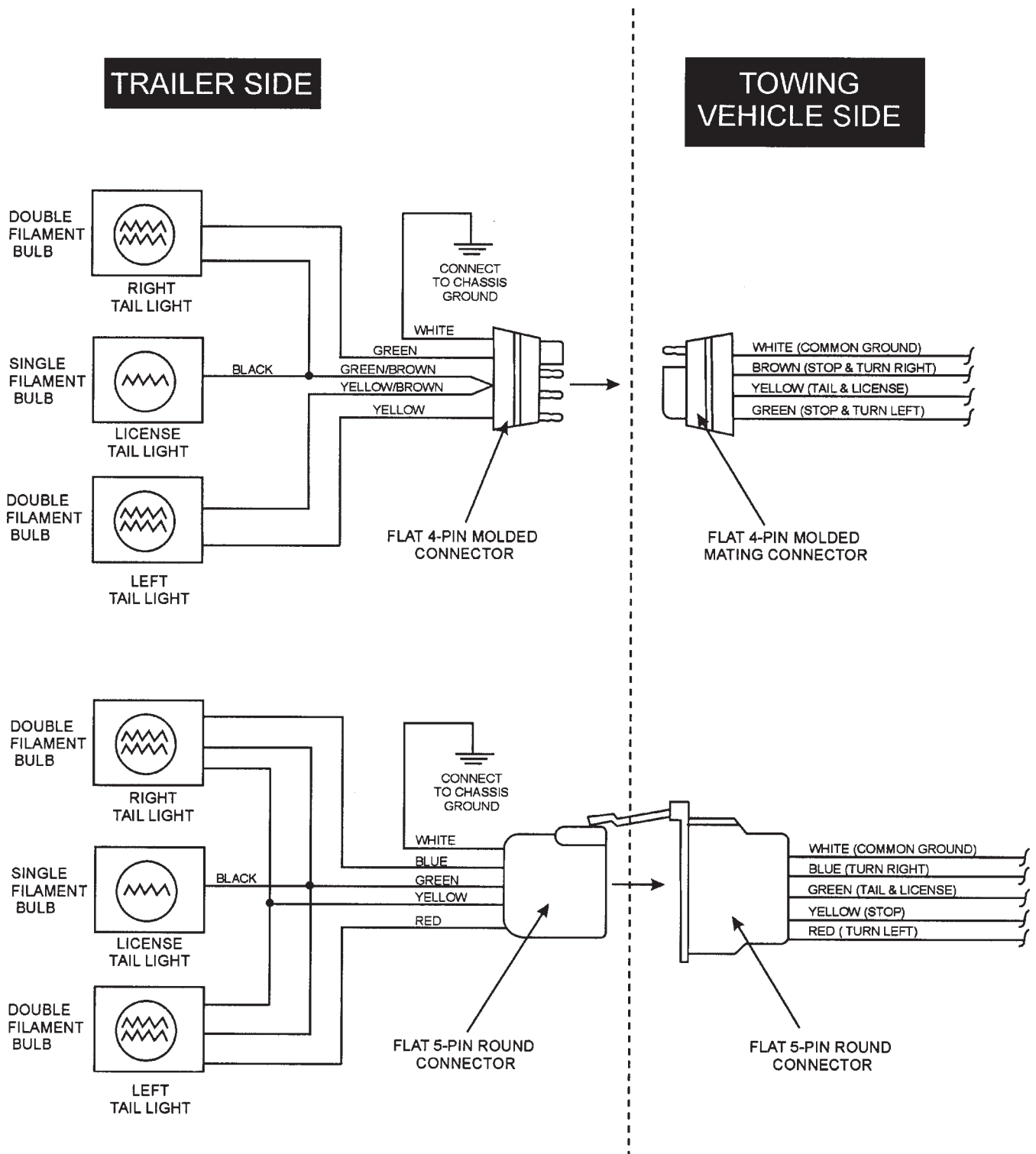

Figure 3. Wheel Lug Nuts Tightening Sequence

NOTE

NEVER use an pneumatic air gun to tighten wheel lug nuts.

DCA-25SSIU — TRAILER-WIRING DIAGRAM



NOTE:
LIGHTS ARE ORIENTED FROM THE DRIVER'S SEAT

DCA-25SSIU — GENERATOR DECALS

The DCA-25SSIU generator is equipped with a number of safety decals. These decals are provided for operator safety and maintenance information. The illustration below and on the preceding pages show the decals as they appear on the machine. Should any of these decals become unreadable, replacements can be obtained from your dealer.

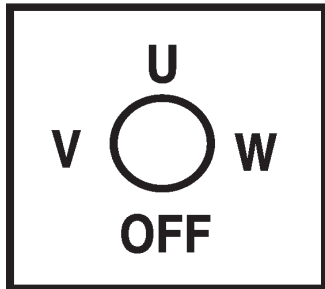

P/N M9520000104

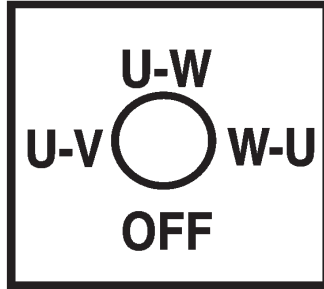

P/N M9520000204

SAFETY INSTRUCTIONS

Improper operation of this machine can cause severe injury or death.

- Read the instruction manual carefully before operating or servicing.

This machine should only be operated by a person with sufficient knowledge and skill to ensure safe operation.

High voltage circuits are located inside the output terminal cover and control panel.

- Close the cover and control panel before operating.

Moving parts and hot surfaces are contained within the enclosure.

- Close all doors and lock them before operating.

M92010030

P/N M9520100304



P/N M9510200002



P/N M950000004



P/N M9500500004

OVER CURRENT RELAY

If it is impossible to reset the CIRCUIT BREAKER, open the control panel and push the RESET BUTTON as below.

M92020010

P/N M9520200104



P/N M9500300104



P/N M9500300004



P/N M9500500104



P/N M9503000103

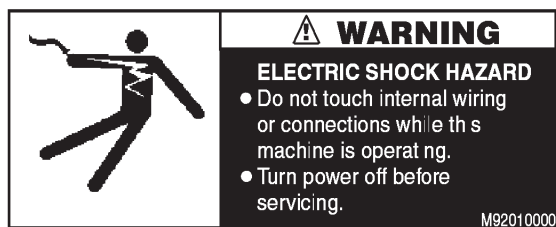

P/N M9520100004



P/N M9520100401

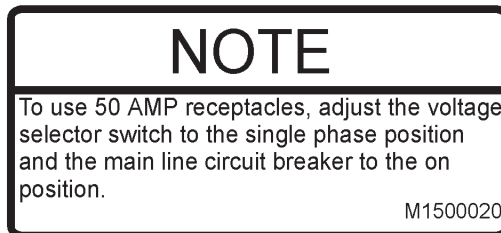

P/N M1550000204

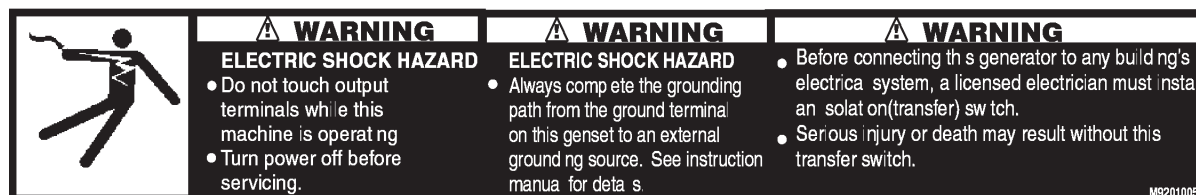

P/N M9520100503

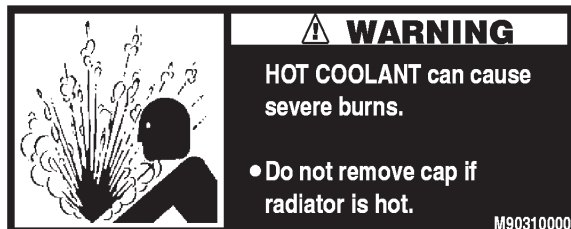

P/N M9503100004

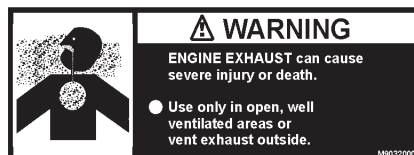

P/N M9503200004



P/N M9520100204

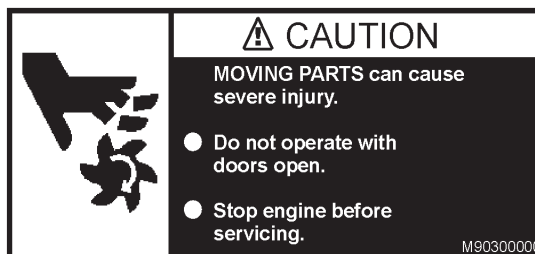

P/N M9503000004

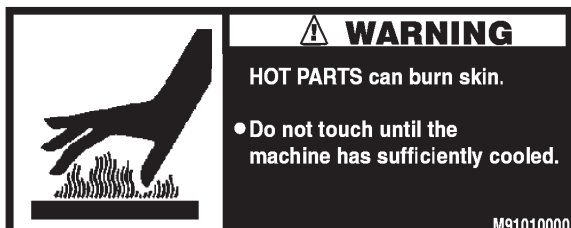

P/N M9510100004

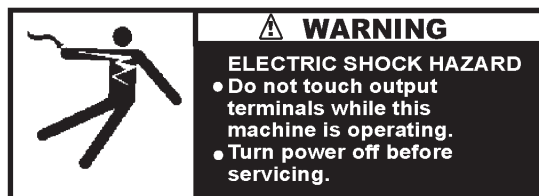

P/N M9520100503

DCA-25SSIU — SPECIFICATIONS

Table 5. Specifications		
Generator Specifications		
Model	DCA-25SSIU	
Type	Revolving field, self ventilated, open protected type synchronous	
Armature Connection	Star with Neutral	Zig Zag
Phase	3	Single
Standby Output	26.5 KVA (21.2 KW)	15.3KW
Prime Output	25 KVA (20 KW)	14.4KW
Voltage	240V or 480V	240/120V
Frequency	60 Hz	
Speed	1800 rpm	
Power Factor	0.8	1
Aux. AC Power	Single Phase, 60 Hz	
Voltage	120 V	
Output	4.8 KW (2.4 KW x 2)	
Engine Specifications		
Model	Isuzu QD-6(C240)	
Type	4 Cycle, water-cooled, swirl combustion chamber	
No. of Cylinders	4 cylinders	
Bore x Stroke	3.38 in. x 4 in. (86 mm x 102 mm)	
Rated Output	30.6HP/1800 rpm	
Displacement	144 cu. in. (2369cc)	
Starting	Electric	
Coolant Capacity	2.9 gal. (11 liters)	
Lube Oil Capacity	1.45 gal. (5.5 liters)	
Fuel Consumption	1.65 gal. (6.3L)/hr at full load	1.3 gal. (5.0L)/hr at 3/4 load
	0.9 gal. (3.4L)/hr at 1/2 load	0.6 gal. (2.3L)/hr at 1/4 load
Battery	12V- 70AH	
Fuel	#2 Diesel Fuel	

DCA-25SSIU FAMILIARIZATION

Generator

The MQ Power Model DCA-25SSIU is a 20 kW **generator** that is designed as a high quality portable (requires a trailer for transport) power source for telecom sites, lighting facilities, power tools, submersible pumps and other industrial and construction machinery.

Engine Operating Panel

The "Engine Operating Panel" is provided with the following:

- Tachometer
- Water Temperature Gauge
- Oil Pressure Gauge
- Charging Ammeter Gauge
- Fuel level gauge
- Engine Throttle Lever
- Pre-Heat Light
- Alarm Lights
- Panel Light
- Panel Light Switch
- Starter Switch

Generator Control Panel

The "Generator Control Panel" is provided with the following:

- Output Voltage Adjustment Knob
- Frequency Meter (Hz)
- AC Ammeter (Amps)
- AC Voltmeter (Volts)
- Ammeter Change-Over Switch
- Voltmeter Change-Over Switch
- Main Circuit Breaker 60 amps
- Over-Current Relay

Output Terminal Panel

The "Output Terminal Panel" is provided with the following:

- Three 120V output receptacles, 50 amp
- Two 120V output receptacles, 20 amp
- 3 Circuit Breakers 240V @65 amps
- 2 GFCI Circuit Breakers 120V@ 20amps

Open Delta Excitation System

The DCA-25SSIU generator is equipped with the state of the art "**Open-Delta**" excitation system. The open delta system consist of an electrically independent winding wound among stationary windings of the AC output section.

There are four leads: A, B, C and D. During light loads, the power to the **Automatic Voltage Regulator (AVR)** is supplied from the leads parallel connections of B&C. When loads increase, the AVR switches and accepts power from leads A&D. The output of leads A&D increase proportionally with load. This of adding the voltages to each phase provides better voltage response during heavy loads.

The connections of the AVR to the AC output windings are for sensing only. No power is required from these windings.

The open-delta design provides virtually unlimited excitation current, offering maximum motor starting capabilities. The excitation does not have a "**fixed ceiling**" and responds according the demands of the required load.

Engine

The **DCA-25SSIU** is powered by a 4 cycle, water cooled, turbocharged Isuzu QD60(C640) **diesel** engine. This engine is designed to meet every performance requirement for the generator. Reference Table 5, page 19 for engine specifications.

In keeping with MQ Power's policy of constantly improving its products, the specifications quoted herein are subject to change without prior notice.

The basic controls and indicators for the DCA-25SSIU generator are addressed on the following pages.

Mechanical Governor System

The mechanical governor system control the RPM of the engine. When the engine demands increase or decrease, the mechanical governor system regulates the frequency to $\pm 5\%$. The electronic governor option limits frequency fluctuation to $\pm 0.25\%$.

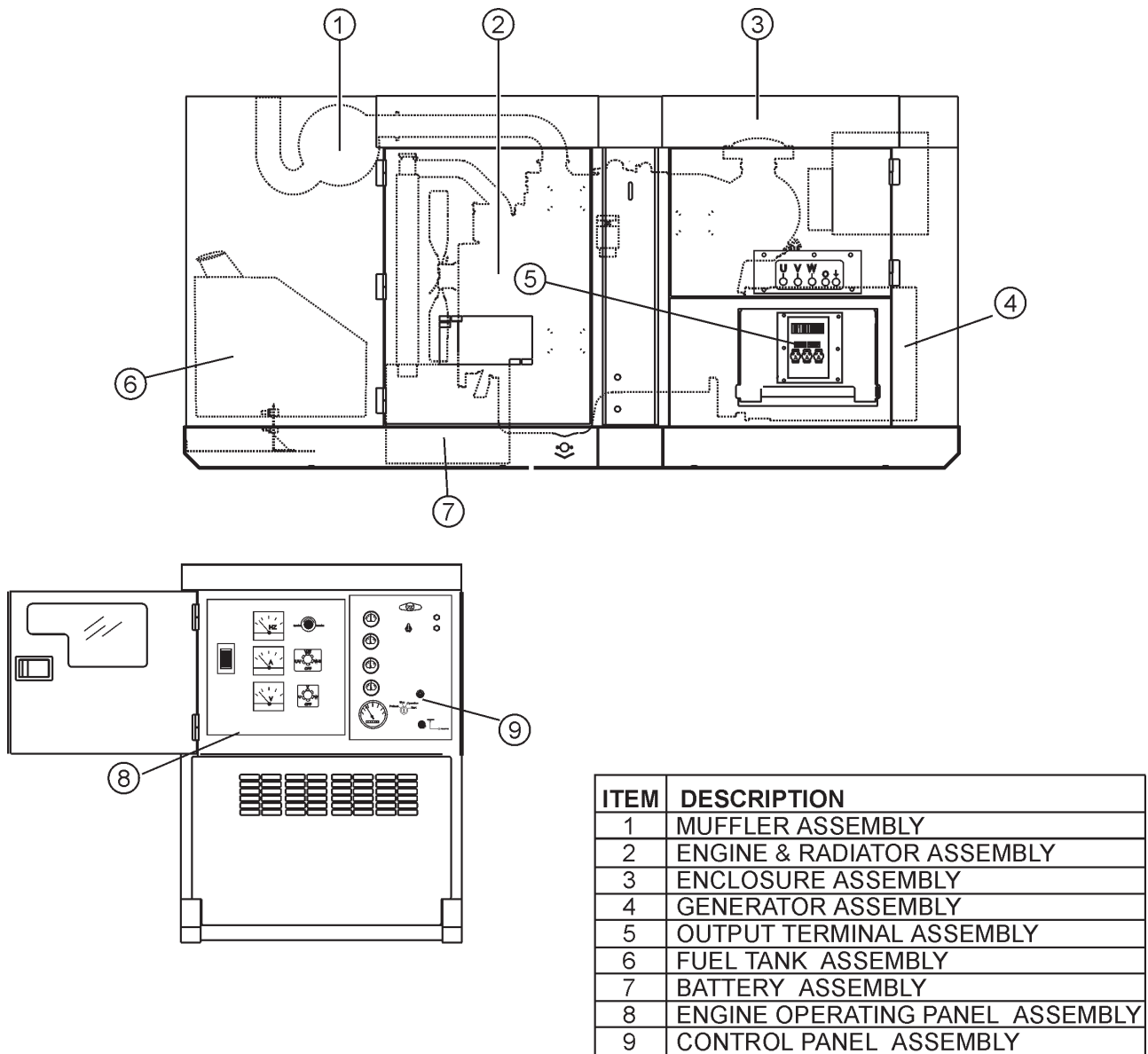

Figure 4. Major Components

DCA-25SSIU — DIMENSIONS (TOP, SIDE AND FRONT)

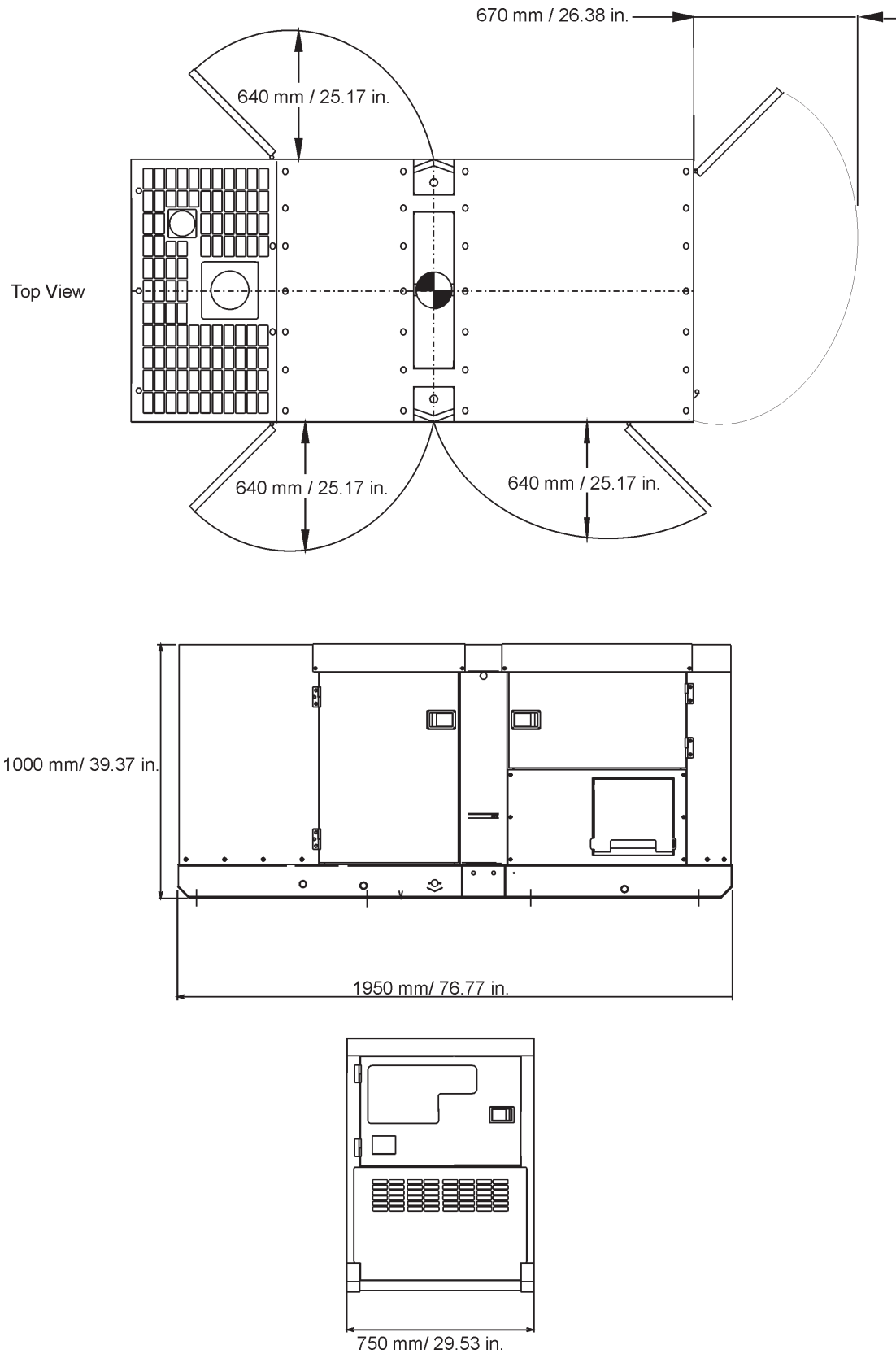
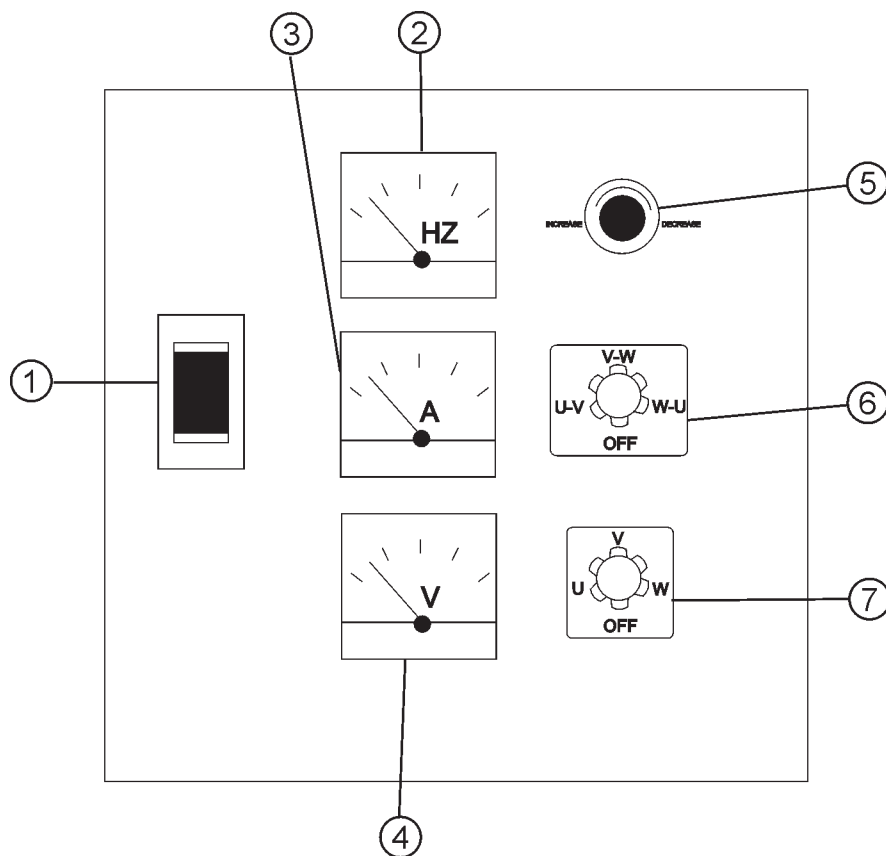

Figure 5. Dimensions



NO	ITEM
1	CIRCUIT BREAKER
2	FREQUENCY METER
3	AC AMMETER
4	AC VOLTMETER
5	VOLTAGE REGULATOR
6	AMMETER CHANGE-OVER SWITCH
7	VOLTMETER CHANGE-OVER SWITCH

Figure 6. Control Panel

The definitions below describe the controls and functions of the DCA-25SSIU " **Control Panel** " (Figure 6).

1. **Main Circuit Breaker** – This three-pole, 60 Amp main breaker is provided to protect the UNV voltage output terminals from overload.
2. **Frequency Meter** – Indicates the output frequency in hertz (Hz). Normally 63 Hz \pm 0.5 Hz .
3. **AC Ammeter** – Indicates the amount of current the load is drawing from the generator.
4. **AC Voltmeter** – Indicates the output voltage present at the UVW or output terminals.
5. **Voltage Regulator Control** – Allows manual adjustment of the generator's output voltage.
6. **Ammeter Change-Over Switch** – This switch allows the AC ammeter to indicate the current flowing to the load connected to any phase of the output terminals, or to be switched off.
7. **Voltmeter Change-Over Switch** – This switch allows the AC voltmeter to indicate phase to phase voltage between any two phases of the output terminals or to be switched off.

DCA-25SSIU — ENGINE OPERATING PANEL

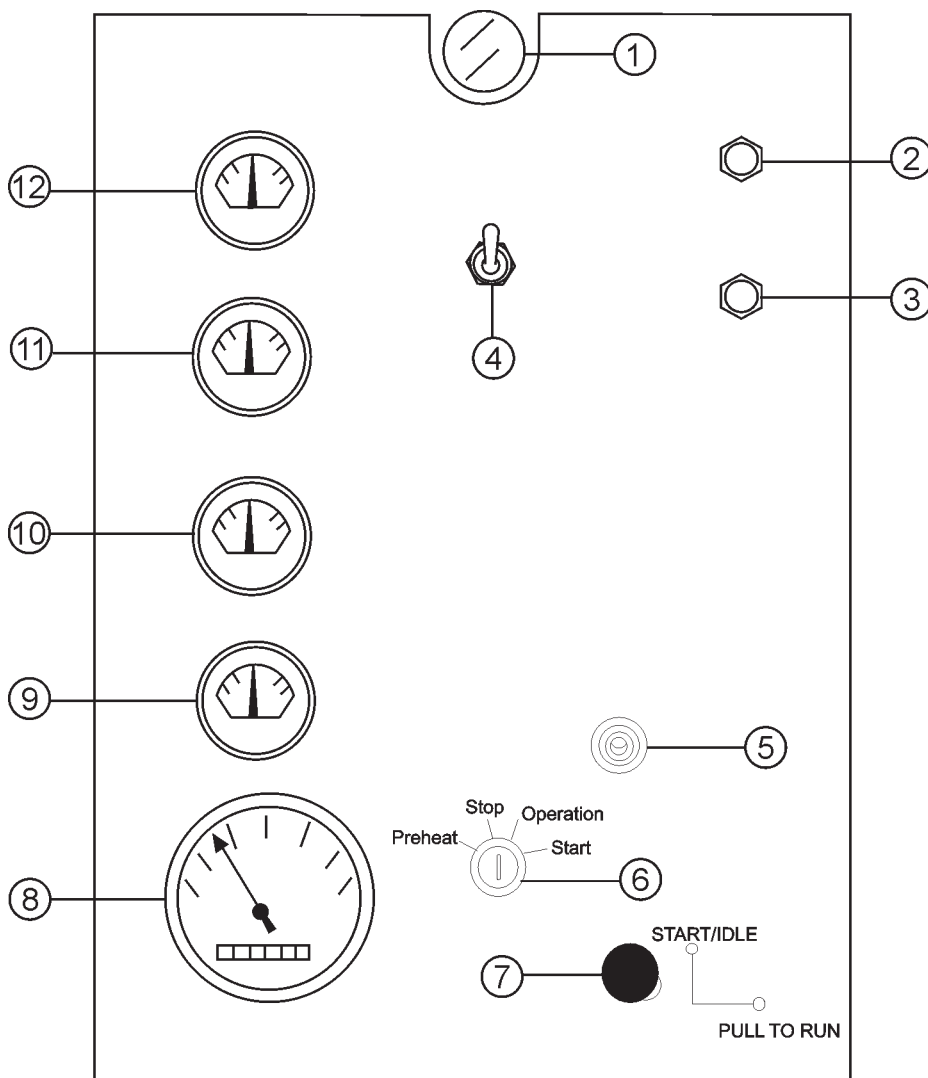

NO	ITEM
1	PANEL LIGHT
2	OIL PRESSURE INDICATOR
3	WATER TEMPERATURE INDICATOR
4	PANEL LIGHT SWITCH
5	PREHEAT INDICATOR
6	IGNITION SWITCH
7	ENGINE THROTTLE LEVER
8	TACHOMETER
9	FUEL GAUGE
10	CHARGING AMMETER GAUGE
11	WATER TEMPERATURE GAUGE
12	OIL PRESSURE GAUGE

Figure 7. Engine Operating Panel

The definitions below describe the controls and functions of the DCA-25SSIU " **Engine Operating Panel** " (Figure 7).

1. **Panel light** - Normally used in dark places or at night. When activated, panel will luminate. When the generator is not in use, turn the panel light switch to the 'OFF' position.
2. **Oil Pressure Lamp** - This light will luminate if the oil pressure exceeds 15 psi and will shut off the engine.
3. **Water Temperature Lamp** - This light will luminate if the water temperature exceeds 215°F and will shut off the engine.
4. **Panel light switch**- When activated, will turn on control panel light.
5. **Pre-Heat Indicator** - This light will luminate once the engine is warmed to an operating temperature.
6. **Ignition Switch** - This switch is used with a key to start, preheat, and stop the engine..
7. **Engine Throttle Lever** - To change the speed of the engine from idle to high, pull and turn the handle.
8. **Tachometer** – Indicates engine speed in RPM's for 60 Hz operation. This meter should indicate 1800 RPM's when the rated load is applied. In addition a built in hour meter will record the number of operational hours that the generator has been in use.
9. **Fuel Gauge** - Indicates amount of diesel fuel available
10. **Charging Ammeter Gauge** – Indicates the current being supplied by the engine's alternator which provides current for generator's control circuits and battery charging system.
11. **Water Temperature Gauge** – During normal operation this gauge be should read between 165° to 203°F.
12. **Oil Pressure Gauge** – Normal operation should be about 42~71 psi. When starting the generator the oil pressure may read a bit higher, but after the engine warms up the oil pressure should return to normal.

Output Terminal Panel

The output control panel is located on the rear (control panel) end of the generator. The UVW lugs are protected by a face plate cover that can be secured in the close position by a pad lock.

120 Volt Receptacle

One GFCI Duplex NEMA 5-20R (120V, 20 Amp) receptacle is located on the output terminal. This receptacle can be used anytime the generator is in operation. The receptacle is controlled by the circuit breaker located on the control panel.

The reset button will reset the receptacle after being tripped. Pressing the "Test Button" (See Figure 8) in the center of this receptacle will check the GFCI function. The receptacle should be tested at least once a month.

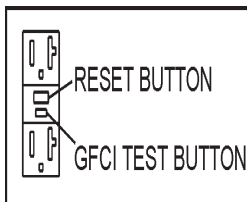

Figure 8. GFCI Test Button

Connecting Load

Loads can be connected to the generator by the UVW Lugs or the duplex receptacle. (See Figure 9). Make sure to read the operation manual before attempting to connect a load to the generator.

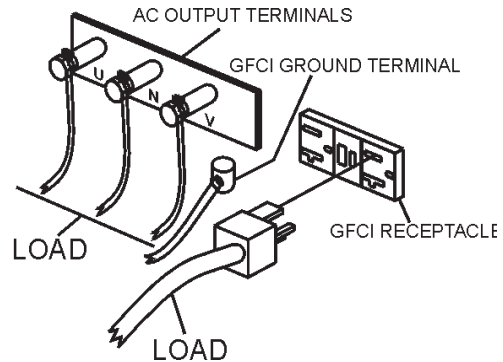

Figure 9. Connecting Loads

Circuit Breakers

To protect the generator from an overload, a 3-pole, 60 amp, **main** circuit breaker is provided to protect the UVW output terminals from overload. In addition two single-pole, 20 amp **GFCI** circuit breakers are provided to protect the GFCI receptacles from overload. Three 50 amp circuit breakers have also been provided to protect the load side of the generator from overload. Make sure to switch **ALL** circuit breakers to the "OFF" position prior to starting the engine.

Maximum Output

The entire load connected to the UVW lugs and all four slots in the duplex receptacle must not exceed 22 kW in standby or 20 kW in prime output.

120V Receptacles - These receptacles can be used anytime the generator is in operation. They are controlled by the circuit breakers above them.

Twist Lock Dual Voltage Receptacles - To use these receptacles, place the voltage selector switch in the single phase 240/120 voltage position and adjust the output voltage to 240 volts with the voltage regulator on the control panel (see Figure 6, page 24). Place the voltmeter change-over switch to the U-W position and the ammeter change-over switch to the U or W to read the output.

DCA-25SSIU — OUTPUT TERMINAL PANEL

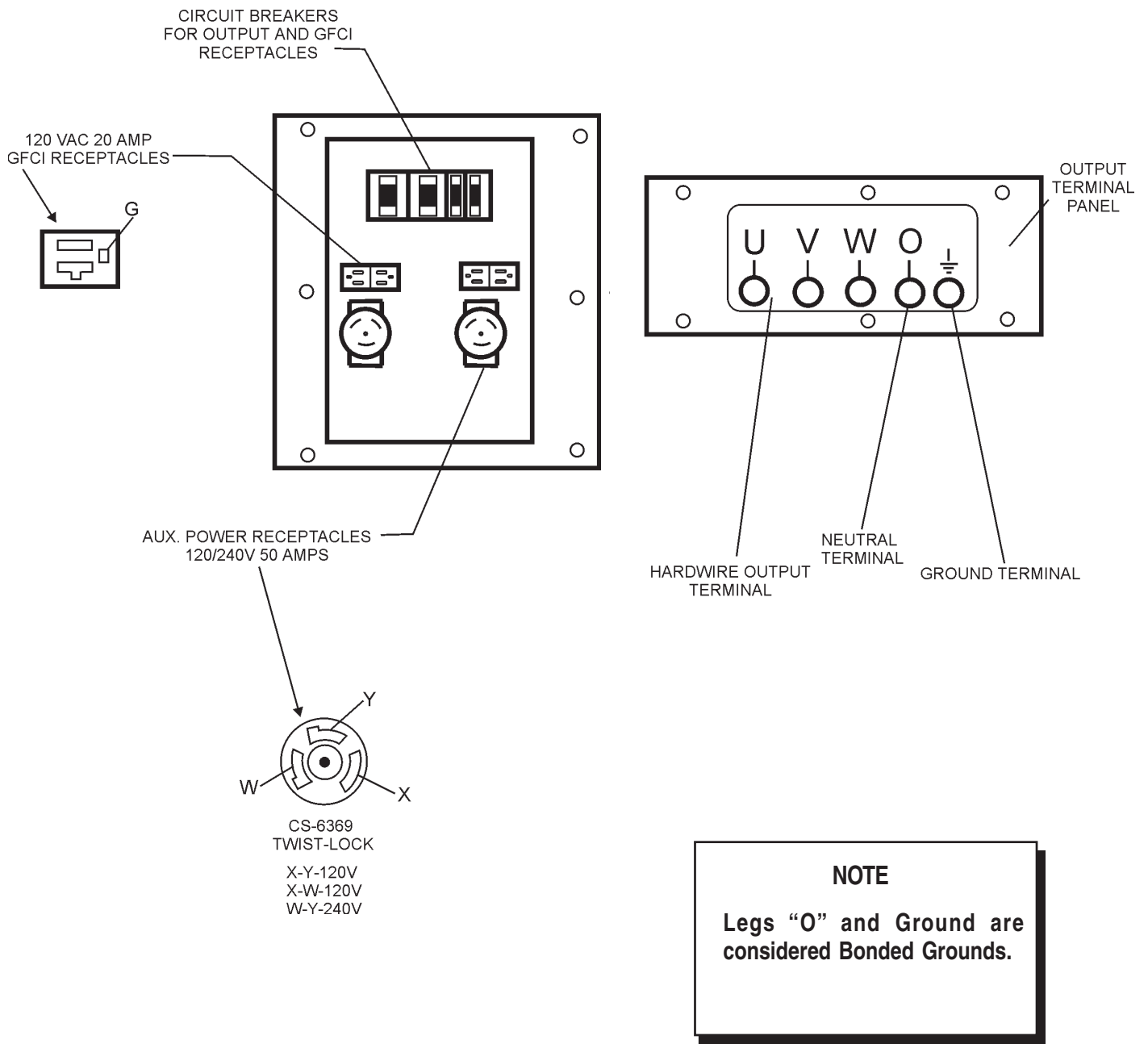

Figure 10. Output Terminal Description

Output Terminal Panel Available Voltages

A wide range of voltages are available to supply load to many different applications. Voltages may be selected by using the voltage selector switch and depending how you hookup your hard wire connection to the generator. To obtain voltages listed, fine adjustment with the voltage regulator on the control panel is necessary. See the table below (Table 6) for a list of available voltages the generator is able to supply.

Over Current Relay

An over current relay is connected to the circuit breaker. During an over current situation, both the circuit breaker and the over current relay may trip. If the circuit breaker can not be reset, the reset button on the over current relay must be pressed. The over current relay is located inside the control box.

Table 6. Voltage Available

Table 6. Voltage Available						
3 Phase (Switchable)	208 VOLT	220 VOLT	240 VOLT	416 VOLT	440 VOLT	480 VOLT
Single Phase (Switchable)	120 VOLT	127 VOLT	139 VOLT	240 VOLT	254 VOLT	277 VOLT

CAUTION :



NEVER switch the voltage selector switch position while the engine is engaged.

Maximum Amps

The following table show the maximum amps the entire generator can provide. Do not exceed the maximum amps listed. (See Table 7)

Voltage Selector Switch Locking Button

The voltage selector switch has a locking button to protect the generator and generator load from being switched while the engine is running. To lock the voltage selector switch, press in the red button located on the lower part of the voltage selector switch, and use a pad lock to hold it into this position.

Table 7. Maximum Amps

Rated Voltage	Maximum Amps
Single Phase 120 Volt	55.5 amps (4 wire)
Single Phase 240 Volt	27.8 amps (4 wire)
Three Phase 240 Volt	60 amps
Three Phase 480 Volt	30 amps

Receptacle Use

When the UVWO terminals are providing power, the receptacle power available decrease. Do not exceed receptacle power available listed on Table 8.

Table 8. Receptacle Use		
Power in Use		Receptacle Power Available
240/480V 3-Phase	240/120V Single Phase or Twist Lock CS6369	Duplex NEMA 5-20R 120V
25	14.4	0
20.8	13.2	1.2
16.7	12	2.4
12.5	10.8	3.6
8.4	9.6	4.8

How To Read The Output Terminal Gauges

The gauges (Figures 13 and 15) and change-over switches on the control panel **DO NOT** effect the generator output. They are to help observe how much power is being supplied produced at the UVWO legs.

When the voltage selector switch is in the 240/120V position (see Figure 11), place the AC voltmeter change-over switch to the W-U position (Figure 12) and the AC ammeter change-over switch to the U or W position (Figure 14) to read the output on the selected leg.

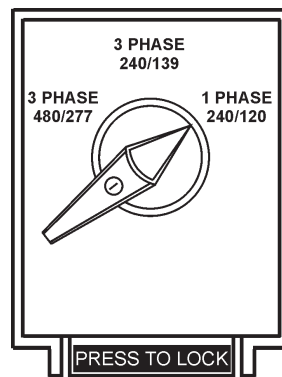

Figure 11. Voltage Selector Switch 240/120V Single Phase Position

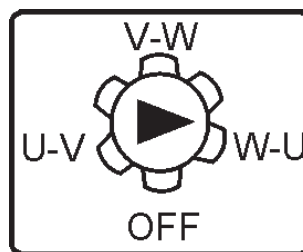

Figure 12. AC Voltmeter Change-over switch (Reading the W-U leg on the output terminal panel)

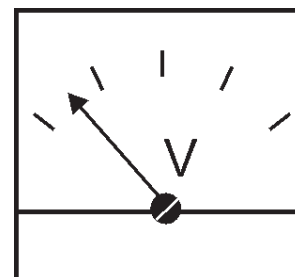

Figure 13. AC Voltmeter Gauge (Volt reading on W-U Lug)

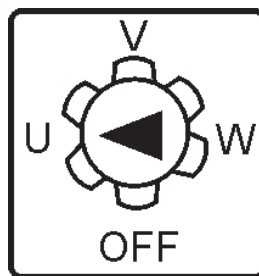

Figure 14. AC Ammeter Change-over Switch (Reading the U leg on the output terminal panel)

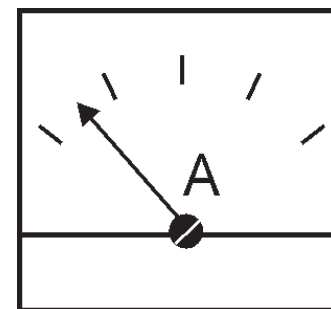

Figure 15. AC Ammeter Gauge (Amp reading on U lug)

NOTE

When using plural single phase voltages, make sure to balance the load on each of the single phase legs.

DCA-25SSIU — OUTPUT VOLTAGE SETUP

240/120V Hard Wire Hookup

With the voltage selector set and locked at 'single phase 240/120' and using single phase 120 volts, it will provide two legs available with 60 amps each (Figure 16).

When using single phase 240 volts, it will provide one leg with 60 amps available (Figure 16).

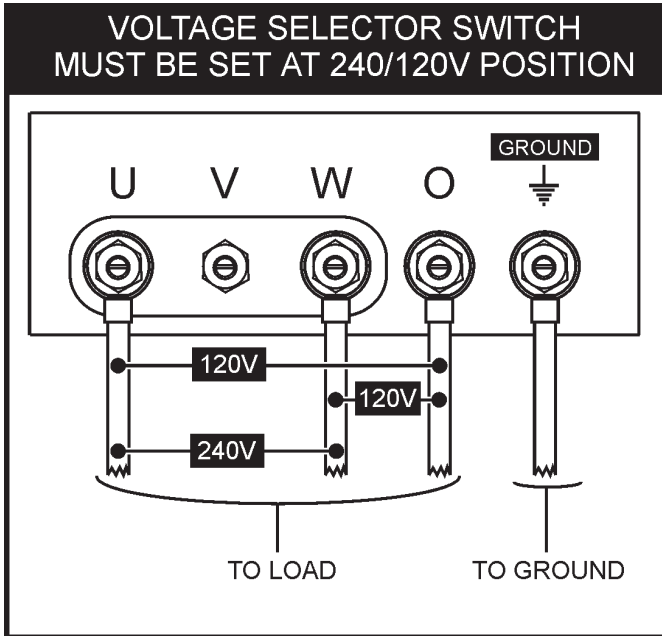

FIGURE 16. Hard Wire Hookup at 240/120V Position

480/240V Hard Wire Hookup

With the voltage selector set and locked at '3 phase 480/277' (Figure 17) and using the 3-phase 240 volt hookup, it will provide one circuit available at 108 amps with any two wires plus the ground (Figure 18).

When using the 3-phase 480 volts hookup, it will provide one circuit available at 50 amps available with all three wires plus ground (Figure 18).

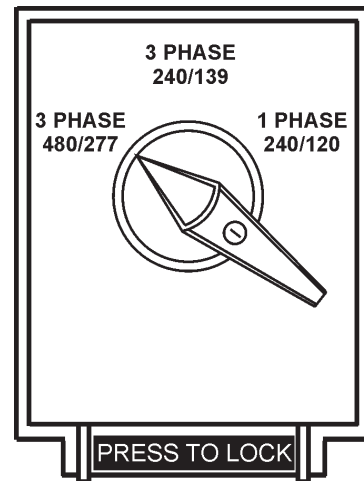

FIGURE 17. Voltage Selector Switch 480/277V Three Phase Position

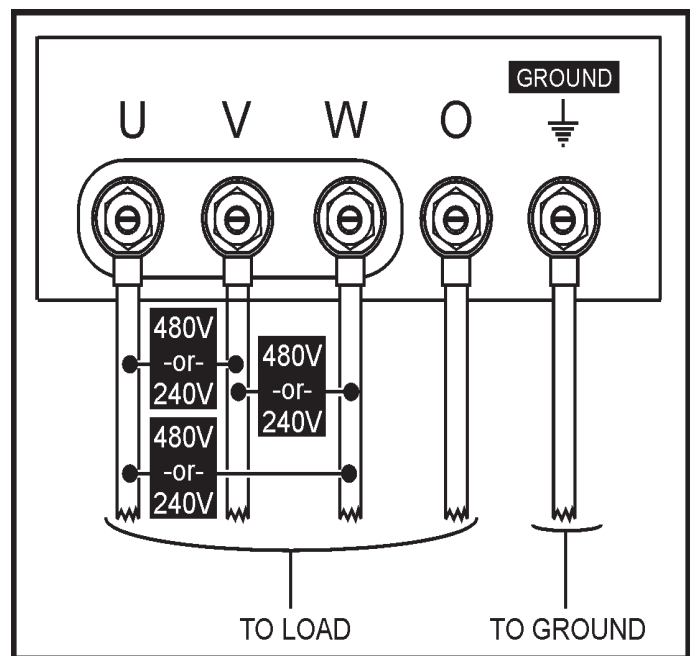

FIGURE 18. Hard Wire Hookup For 240V or 480V

Voltage Selector Switch- 3 Phase 480/277V Position

The following are additional voltages available when the voltage selector switch is in the 3 phase 480/277V position.



Figure 19. Voltage Regulator Knob

3 Phase, 480V, 440V, or 416 Volt

This setting can provide 3-phase power at 480, 440, or 416 volts. After hooking up the hard wires to the lugs as shown in Figure 20, 480 volts can be obtained the voltage regulator knob turned toward maximum; 440 volts can be obtained with the voltage regulator knob is turned down; and 416 volts can be obtained with the voltage regulator knob is at lowest setting.

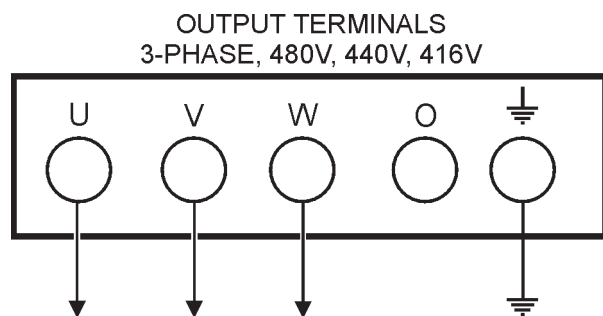

Figure 20. Hard Wire Hookup for Three Phase 480V, 440V, or 416V

Single Phase: 480V, 440V, or 416 Volt

This setting can provide single phase power at 480, 440, or 416 volts. After hooking up the hard wires to the lugs as shown in Figure 21, 480 volts can be obtained the voltage regulator knob turned toward maximum; 440 volts can be obtained with the voltage regulator knob is turned down; and 416 volts can be obtained with the voltage regulator knob is at lowest setting.

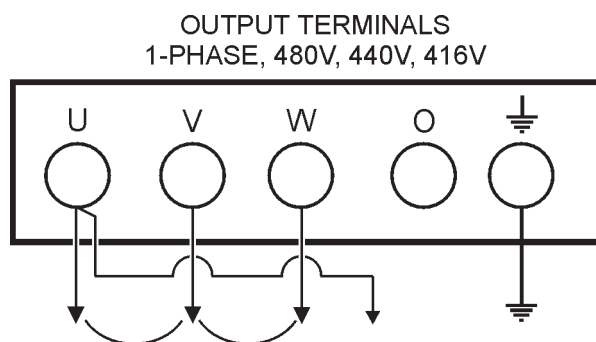

Figure 21. Hard Wire Hookup for Single Phase 480V, 440V, or 416V

Single Phase: 277V, 254V, or 240V

This setting can provide single phase power at 277, 254 or 240 volts. After hooking up the hard wires to the lugs as shown in Figure 22, 277 volts can be obtained the voltage regulator knob turned toward maximum; 254 volts can be obtained with the voltage regulator knob is turned down; and 240 volts can be obtained with the voltage regulator knob is at lowest setting.

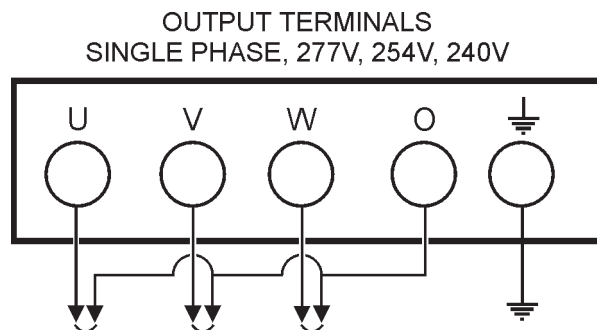

Figure 22. Hard Wire Hookup for Single Phase 277V, 254V, or 240V

Voltage Selector Switch- 3 Phase 240/139V Position

The following are additional voltages available when the voltage selector switch is in the 3 phase 240/139V position.

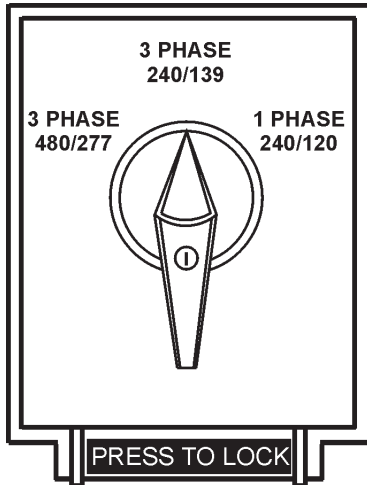

FIGURE 23. Voltage Selector Switch 240/139V Three Phase Position

3 Phase, 240V, 220V, or 208 Volt

This setting can provide 3-phase power at 240, 220, or 208 volts. After hooking up the hard wires to the lugs as shown in Figure 24, 240 volts can be obtained the voltage regulator knob turned toward maximum; 220 volts can be obtained with the voltage regulator knob is turned down; and 208 volts can be obtained with the voltage regulator knob is at lowest setting.

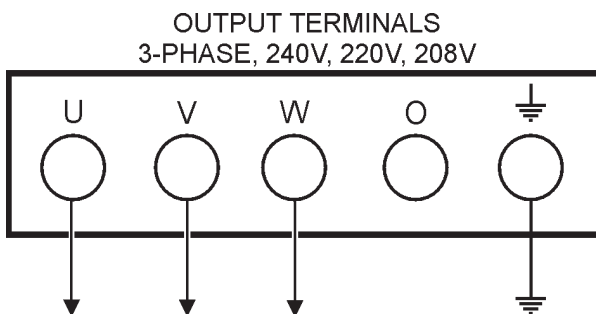

Figure 24. Hard Wire Hookup for Three Phase 240V, 220V, or 208V

Single Phase: 240V, 220V, or 208 Volt

This setting can provide single phase power at 240, 220, or 208 volts. After hooking up the hard wires to the lugs as shown in Figure 25, 240 volts can be obtained the voltage regulator knob turned toward maximum; 220 volts can be obtained with the voltage regulator knob is turned down; and 208 volts can be obtained with the voltage regulator knob is at lowest setting.

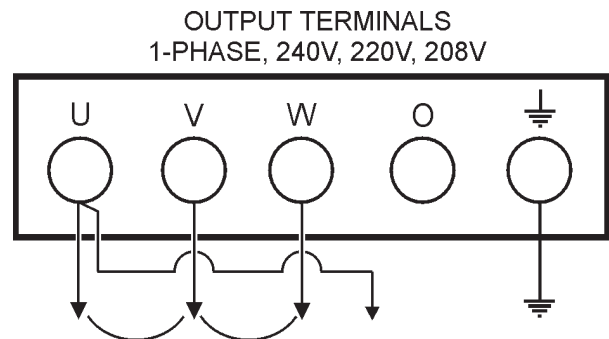

Figure 25. Hard Wire Hookup for Single Phase 240V, 220V, or 208V

Single Phase: 139V, 127V, or 120V

This setting can provide single phase power at 139, 127, or 120 volts. After hooking up the hard wires to the lugs as shown in Figure 26, 139 volts can be obtained the voltage regulator knob turned toward maximum; 127 volts can be obtained with the voltage regulator knob is turned down; and 120 volts can be obtained with the voltage regulator knob is at lowest setting.

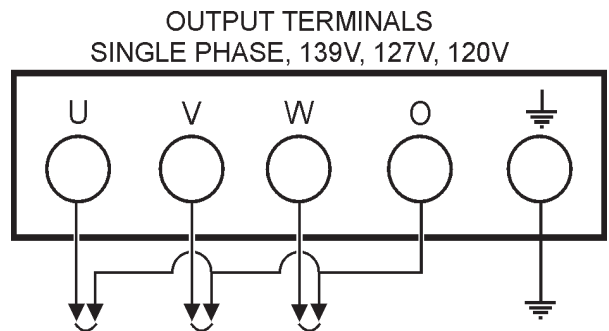

Figure 26. Hard Wire Hookup for Single Phase 139V, 127V, or 120V

Voltage Selector Switch- Single Phase 240/120V

Position

The following are additional voltages available when the 240/120V position.

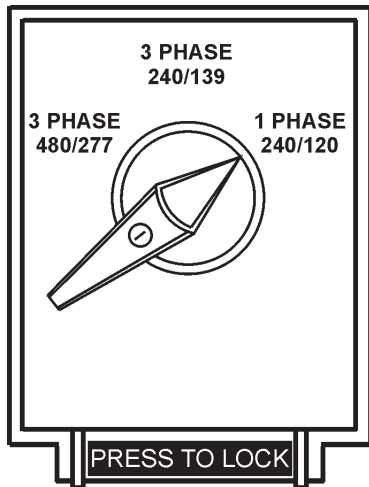

Figure 27. Voltage Selector Switch 240/120V Single Phase Position

Single Phase: 120 Volt

This setting can provide single phase power at 120 volts. After hooking up the hard wires to the lugs as shown in Figure 29, 120 volts can be obtained by using the voltage regulator to fine tune.

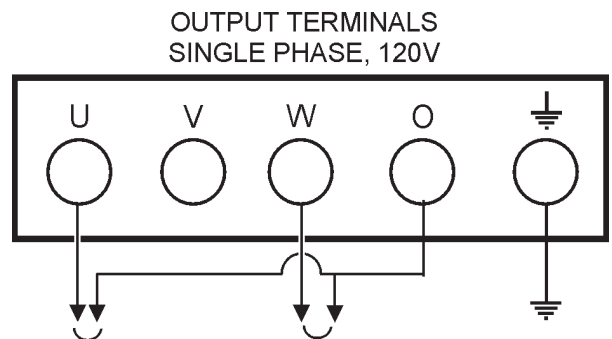

Figure 29. Hard Wire Hookup for Single Phase, 120 volt

Single Phase, 240 Volt

This setting can provide single phase power at 240 volts. After hooking up the hard wires to the lugs as shown in Figure 28, 240 volts can be obtained and using the voltage regulator to fine tune.

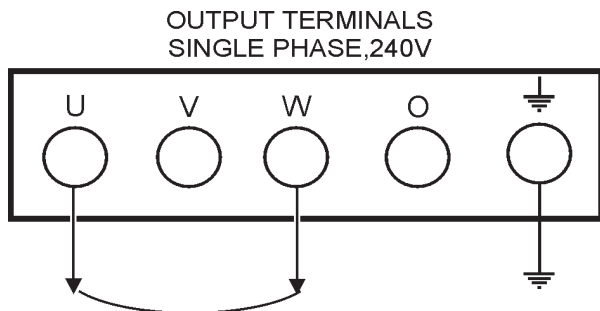

Figure 28. Hard Wire Hookup for Single Phase 240 volt

Outdoor Installation

Install the generator in a location where it will not be exposed to rain or sunshine. Make sure the generator is on secure level ground so that it cannot slide or shift around. Also install the generator in a manner so that the exhaust will not be discharged in the direction of nearby homes.

The installation site must be relatively free from moisture and dust. All electrical equipment should be protected from excessive moisture. Failure to do will result in deterioration of the insulation and will result in short circuits and grounding.

Foreign materials such as dust, sand, lint and abrasive materials have a tendency to cause excessive wear to engine and alternator parts.

CAUTION :



Pay close attention to ventilation when operating the generator inside tunnels and caves. The engine exhaust contains noxious elements. Engine exhaust must be routed to a ventilated area.

Indoor Installation

Exhaust gases from diesel engines are extremely poisonous. Whenever an engine is installed indoors the exhaust fumes must be vented to the outside. The engine should be installed at least two feet from any outside wall. Using an exhaust pipe which is too long or too small can cause excessive back pressure which will cause the engine to heat excessively and possibly burn the valves.

Mounting

The generator must be mounted on a solid foundation (such as concrete) and set firmly on the foundation to isolate vibration of the generator when it is running. The generator must set at least 6 inches above the floor or grade level (in accordance to NFPA 110, Chapter 5-4.1). DO NOT remove the metal skids on the bottom of the generator. They are to resist damage to the bottom of the generator and to maintain alignment.

CAUTION :

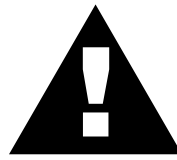

An electric shock may happen when vibrators are used. Pay close attention to handling when operating vibrators and always use rubber boots and gloves to insulate the body from electrical shock.

Generator Grounding

To guard against electrical shock and possible damage to the equipment, it is important to provide a good **EARTH** ground.

Article 250 (Grounding) of the National Electrical Code (NEC) provides guide lines for proper grounding and specifies that the cable ground shall be connected to the grounding system of the building as close to the point of cable entry as practical.

NEC articles 250-64(b) and 250-66 set the following grounding requirements:

1. Use one of the following wire types to connect the generator to earth ground.
 - a. Copper - 10 AWG (5.3 mm²) or larger.
 - b. Aluminum - 8 AWG (8.4 mm²) or larger.
2. When grounding the generator (Figure 30) connect the ground cable between the lock washer and the nut on the generator and tighten the nut fully. Connect the other end of the ground cable to earth ground.
3. NEC article 250-52(c) specifies that the earth ground rod should be buried a minimum of 8 ft. into the ground.

NOTE

When connecting the generator to any buildings electrical system **ALWAYS** consult with a licensed electrician.

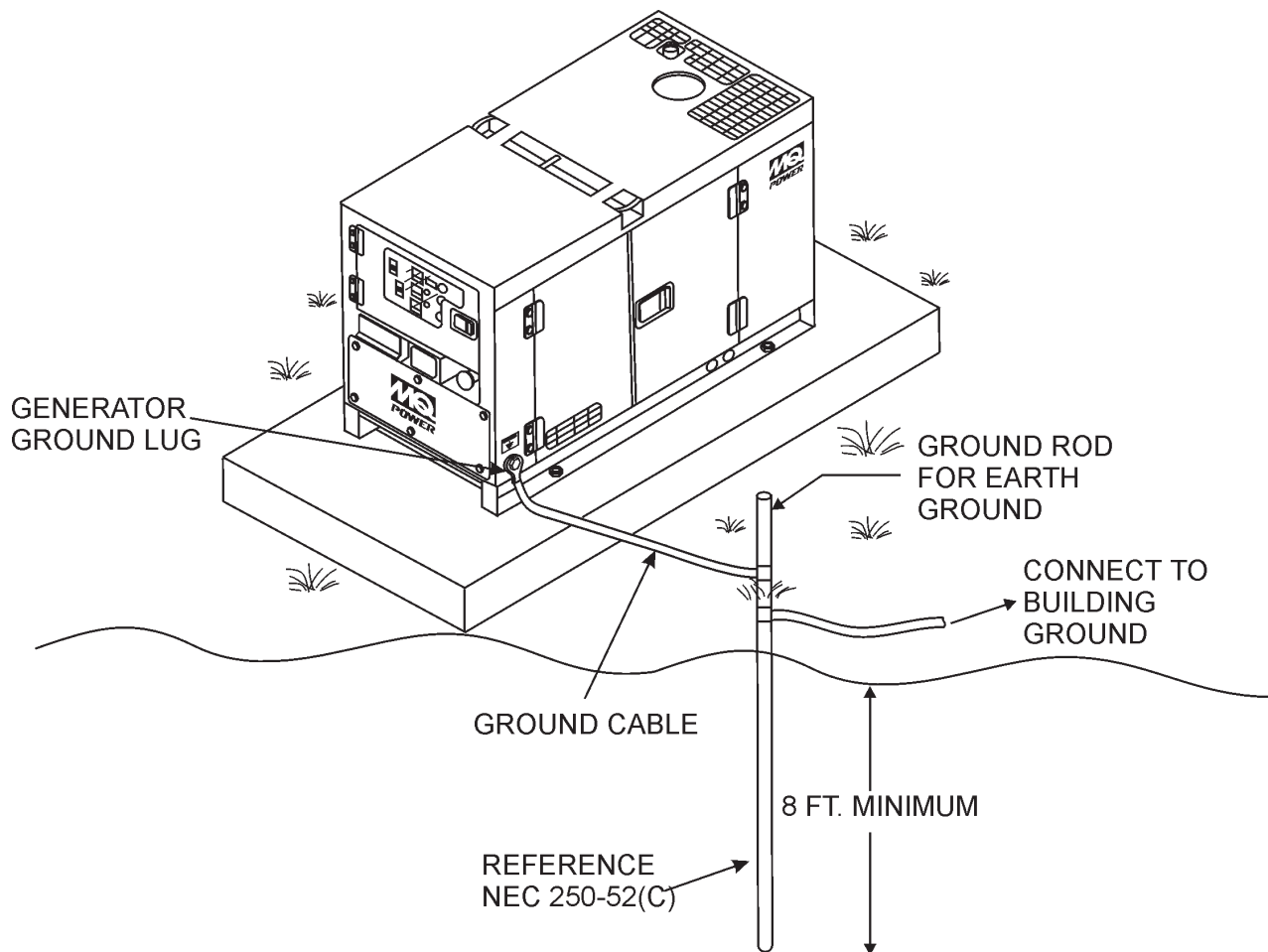

Figure 30. Typical Generator Grounding Application

General Inspection Prior to Operation

The DCA-25SSIU generator has been thoroughly inspected and accepted prior to shipment from the factory. However, be sure to check for damaged parts or components, or loose nuts and bolts, which could have occurred in transit.

Extension Cable

When electric power is to be provided to various tools or loads at some distance from the generator, extension cords are normally used. Cables should be sized to allow for distance in length and amperage so that the voltage drop between the generator and point of use (load) is held to a minimum. Use the Cable Selection Guide (Table 9) as a guide for selecting proper cable size.

Circuit Breakers

To protect the generator from an overload, a 3-pole, 60 amp, **main** circuit breaker is provided to protect the UVW output terminals from overload. In addition two single-pole, 20 amp **GFCI** circuit breakers are provided to protect the GFCI receptacles from overload. Three 50 amp **load** circuit breakers have also been provided to protect the load side of the generator from overload. Make sure to switch **ALL** circuit breakers to the "OFF" position prior to starting the engine.

NOTE

ALWAYS consult with a licensed electrician for correct extension cord wire size.

Table 9. Cable Selection (60 Hz, Single Phase Operation)

Current in Amperes	Load In Watts		Maximum Allowable Cable Length			
	At 120 Volts	At 240 Volts	#10 Wire	#12 Wire	#14 Wire	#16 Wire
2.5	300	600	1000 ft.	600 ft.	375 ft.	250 ft.
5	600	1200	500 ft.	300 ft.	200 ft.	125 ft.
7.5	900	1800	350 ft.	200 ft.	125 ft.	100 ft.
10	1200	2400	250 ft.	150 ft.	100 ft.	
15	1800	3600	150 ft.	100 ft.	65 ft.	
20	2400	4800	125 ft.	75 ft.	50 ft.	
CAUTION: Equipment damage can result from low voltage.						

Lubrication Oil

Fill the engine crankcase with lubricating oil through the filler hole, but do not overfill. Make sure the generator is level. With the dipstick inserted all the way, verify that the oil level is maintained between the two notches (Figure 31) on the dipstick. See Table 10 for proper selection of engine oil. Use only CC grade or higher.

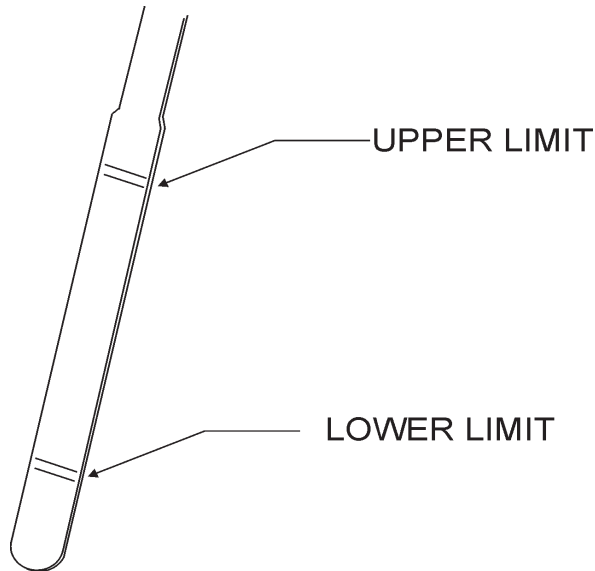

Figure 31. Engine Oil Dipstick

When checking the engine oil, be sure to check if the oil is clean and viscous. If the oil is not clean, drain the oil by removing the oil drain plug, and refill with the specified amount of oil as outlined in the **Isuzu Engine Operator's Manual**.

Fuel

Fill the fuel tank with clean and fresh **diesel fuel**. **DO NOT** fill the tank beyond capacity.

Pay attention to the fuel tank capacity when replenishing fuel. Refer to the fuel tank capacity listed on page 19 Specification Table 5.

The fuel tank cap must be closed tightly after filling. Handle fuel in a safety container. If the container does not have a spout, use a funnel. Wipe up any spilled fuel immediately.

CAUTION :

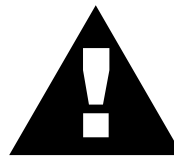

Never fill the fuel tank while the engine is running or in the dark. Gasoline spillage on a hot engine can cause a fire or explosion. If gasoline spillage occurs, wipe up the spilled gasoline completely to prevent fire hazards.

Coolant

Use only drinkable tap water. If hard water or water with many impurities is used, the inside of the engine and radiator may become coated with deposits and cooling efficiency will be reduced. See maintenance section on page 42 and 43 on instructions to flush out radiator.

An anticorrosion additive added to the water will help prevent deposits and corrosion in the cooling system.

Table 10. Recommended Motor Oil

Ambient Temperature Range	Type Oil
-30°~0°C (-22°~32°F)	SAE 10W or SAE10W-30
0°~25°C (32°~77°F)	SAE 30 or SAE15w-40W, 20W-40
Above 25°C (86°F)	SAE 40

CAUTION :



When adding coolant or antifreeze to the radiator, do not remove the radiator cap until the unit has completely cooled.

Day-to-day addition of coolant is done from the reserve tank. When adding coolant to the radiator, **DO NOT** remove the radiator cap until the unit has completely cooled. See Table 11. for engine, radiator, and reserve tank coolant capacities. Make sure the coolant level in the reserve tank is always between the "H" and the "L" markings.

Table 11. Coolant Capacity

Engine and Radiator	2.9 Gal. (11 Liters)
Reserve Tank	0.27 Gal. (1 Liter)

Operation in Freezing Weather

When operating in freezing weather, be certain the proper amount of antifreeze (Table 12) has been added.

Table 12. Anti-Freeze Operating Temperatures

Vol % Anti-Freeze	Freezing Point		Boiling Point	
	°C	°F	°C	°F
40	-24	-12	106	222
50	-37	-34	108	226

NOTE

When the antifreeze is mixed with water, the antifreeze mixing ratio must be less than 50%.

Cleaning the Outer Radiator

The engine may overheat if the radiator fins become overloaded with dust or debris. Periodically clean the radiator fins with compressed air. Cleaning inside the radiator is dangerous, so clean only with the engine turned off and the battery disconnected.

Air Cleaner

Periodic cleaning/replacement is necessary. Inspect it in accordance with the **Kubota Engine Owner's Manual**.

Fan Belt Tension

A slack fan belt may contribute to overheating, or to insufficient charging of the battery. Inspect the fan belt for damage and wear and adjust it in accordance with the **Kubota Engine Owner's Manual**.

The fan belt tension is proper if the fan belt bends 10 to 15 mm (Figure 32) when depressed with the thumb as shown below. Never place hands near the belts or fan while the generator is running.

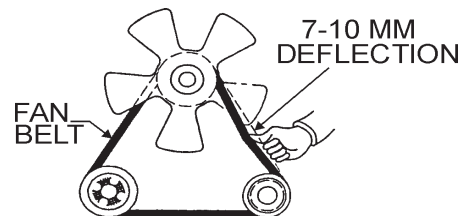

Figure 32. Fan Belt Tension

CAUTION :



Never place hands near the belts or fan while the generator set is running.

Adjusting Fan Belt

If the fan belt does not have the 10 to 15mm deflection follow the procedure below to adjust:

- Loosen the alternator adjusting plate and alternator mounting bolt.
- Pivot the alternator at the mounting bolt toward the engine left or right until the belt reflects the proper tension.
- Tighten the mounting bolt and the adjusting bolt.

Battery

This unit is of negative ground. **DO NOT** connect in reverse. Always maintain battery fluid level between the specified marks. Battery life will be shortened, if the fluid level is not properly maintained. Add only distilled water when replenishment is necessary. **DO NOT** over fill.

The battery is sufficiently charged if the specific gravity of the battery fluid is 1.28 (at 68° F). If the specific gravity should fall to 1.245 or lower, it indicates that the battery is dead and needs to be recharged or replaced.

Check to see whether the battery cables are loose. Poor contact may result in poor starting or malfunctions. Always keep the terminals firmly tightened. Coating the terminals with a thin film of grease will help to inhibit corrosion.

Battery Cable Installation

ALWAYS be sure the battery cables (Figure 33) are properly connected to the battery terminals as shown below. The **RED** cable is connected to the positive terminal of the battery, and the **BLACK** cable is connected to the negative terminal of the battery.

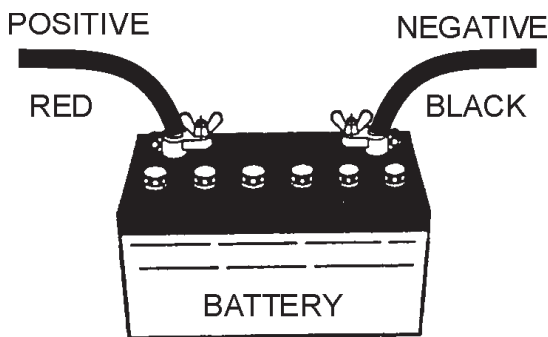
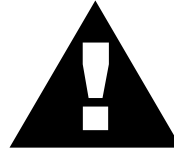

Figure 33. Battery Connections

CAUTION :



If the battery cable is connected incorrectly, damage to the generator will occur. Pay close attention to the polarity of the battery when connecting the battery.

When connecting battery do the following:

1. **DO NOT** connect the battery cables to the battery terminals when the key is in the ignition and is set in 'START' mode. **ALWAYS** remove the key from the ignition and the ignition switch is in the OFF position when connecting the battery.
2. Place a small amount of grease around both battery terminals. This will ensure a good connection and will help prevent corrosion around the battery terminals.

CAUTION :

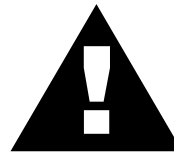

Inadequate battery connections may cause poor starting of the generator, and create other malfunctions.

Wiring

Inspect the entire generator for bad or worn electrical wiring or connections. If any wiring or connections are exposed (insulation missing) replace wiring immediately.

Piping and Hose Connection

Inspect all piping, oil hose, and fuel hose connections for wear and tightness. Tighten all hose clamps and check hoses for leaks.

If any hose (fuel or oil) lines are defective replace them immediately.

Single Phase Load

Always be sure to check the nameplate on the generator and equipment to insure the wattage, amperage and frequency requirements are satisfactorily supplied by the generator for operating the equipment.

Generally, the wattage listed on the nameplate of the equipment is its rated output. Equipment may require 130—150% more wattage than the rating on the nameplate, as the wattage is influenced by the efficiency, power factor and starting system of the equipment.

When the voltage selector switch is in single phase (240/120V position), place the AC voltmeter change-over switch to the U-W position and the AC ammeter change over-switch to the U or W position to read the output.

NOTE

If wattage is not given on the equipment's name plate, approximate wattage may be determined by multiplying nameplate voltage by the nameplate amperage.

$$\text{WATTS} = \text{VOLTAGE} \times \text{AMPERAGE}$$

The power factor of this generator is 1.0. See Table 13. below when connecting loads.

Table 13. Power Factor By Load

Type Of Load	Power Factor
Single-phase induction motors	0.4 - 0.75
Electric heaters, incandescent lamps	1.0
Fluorescent lamps, mercury lamps	0.4 - 0.9
Electronic devices, communication equipment	1.0
Common power tools	0.8

Three Phase Load

When calculating the power requirements for 3-phase power use the following equation:

$$\text{KVA} = \frac{\text{VOLTAGE} \times \text{AMPERAGE} \times \sqrt{3} (1.732)}{1000}$$

CAUTION:



Motors and motor-driven equipment draw much greater current for starting than during operation.

An inadequate size connecting cable which cannot carry the required load can cause a voltage drop which can burn out the appliance or tool and overheat the cable.

- When connecting a resistance load such as an incandescent lamp or electric heater, a capacity of up to the generating set's rated output (kW) can be used.
- When connecting a fluorescent or mercury lamp, a capacity of up to the generating set's rated output (kW) multiplied by 0.6 can be used.
- When connecting an electric drill or other power tools, pay close attention to the required starting current capacity.

If wattage is not available on the equipment, approximate wattage may be determined by multiplying the nameplate voltage by the nameplate amperage for three-phase:
 $\text{WATTS} = 1.732 \times \text{VOLTAGE} \times \text{AMPERAGE}$

CAUTION:



Before connecting this generator to any building's electrical system, a licensed electrician must install an isolation (transfer) switch. Serious injury or death may result without this transfer switch.

NOTE

If output (kVA) is not given on the equipment nameplate, approximate output may be determined by multiplying voltage by amperage by $\sqrt{3}$ and 1.732.

WARNING:



The engine's exhaust contains harmful emissions. **ALWAYS** ventilate the exhaust when operating inside tunnels, excavations or buildings. Direct exhaust away from nearby personnel.

Before Starting Engine

1. Check the lubricating oil level prior to starting the engine. Make sure the generator is level. The oil level must be maintained between two notches on the dipstick.
2. When there is not enough lubricating oil, fill the crankcase with high grade motor oil. Use a high quality detergent oil classified CC or higher (See Table 8 on page 33).
3. Check the coolant level in the radiator and subtank. Replenish with antifreeze as necessary. Always maintain the coolant level between the **FULL** and **LOW** markings on the coolant container. Be sure that the radiator cap is fastened securely.
4. Check the fuel level on the fuel gauge. If fuel is low, fill the fuel tank with clean fresh unleaded automotive diesel. If diesel spillage occurs, completely wipe up the spilled fuel immediately.

Before Starting Generator and Control Panel

CAUTION:



NEVER start the engine with the **main, GFCI** or **load** circuit breakers in the **ON** position.

1. Be sure to disconnect the electrical load and switch the **main, load** and **G.F.C.I.** circuit breakers (Figure 34) to the "OFF" position prior to starting the engine.

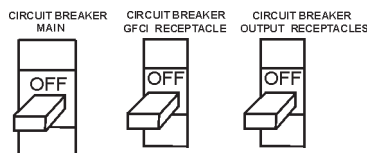

Figure 34. Main, GFCI and Load Circuit Breakers

2. Connect the load to the UVW terminals as shown in Figure 35. These terminals can be found on the output terminal panel, (see page 29 Figure 10). To gain access to the output terminals lift the UVW cover. Tighten terminal nuts securely to prevent load wires from slipping out.

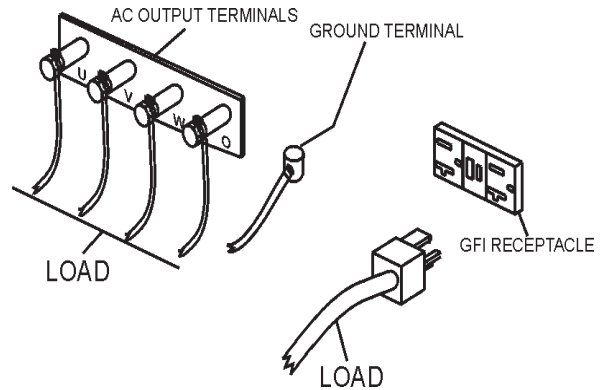

Figure 35. UVW Terminal Lugs (Load)

3. Connect the negative battery cable (BLACK) to the negative post on the battery (Figure 36).

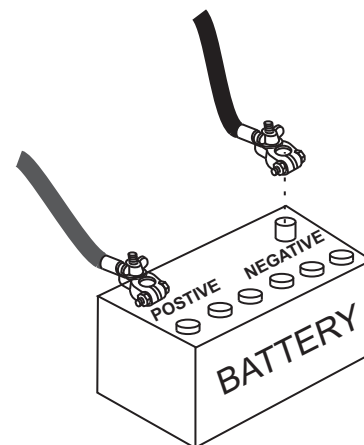

Figure 36. Battery Connections

DCA-25SSIU — GENERATOR START-UP PROCEDURE

4. Close all engine enclosure doors (Figure 37).

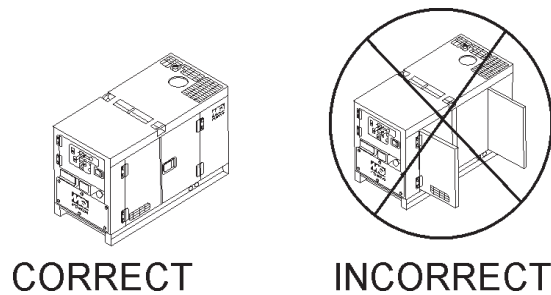

Figure 37. Engine Enclosure Doors

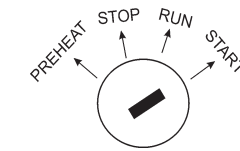

Figure 41. Ignition Switch 'START'

5. Check the voltage selection switch (Figure 38) is at the desired voltage.

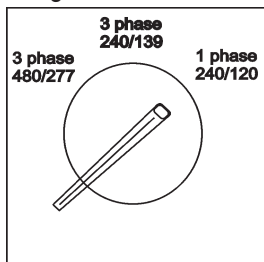

Figure 38. Voltage Selection Switch

8. Once the preheat indicator lights, turn the ignition key to 'START' until the engine starts (Figure 41). Then release the key to 'RUN'.

9. Pull the engine throttle and turn to the right until the metal stop rests against the control panel (Figure 42).

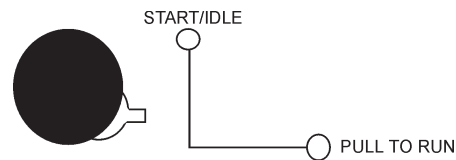

Figure 42. Engine Throttle Lever (high)

6. Make sure the engine throttle (Figure 39) is in 'start/idle'.

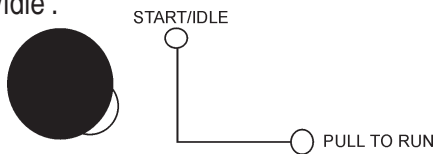

Figure 39. Engine Throttle Lever (low)

10. The generator's frequency meter (Figure 43) displays the 60 cycle output frequency in HERTZ.

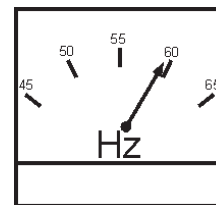

Figure 43. Frequency Meter (Hz)

7. Turn the ignition key to preheat (Figure 40), until the preheat indicator turns on.

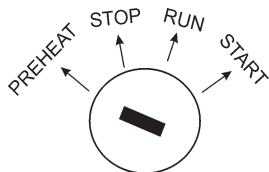

Figure 40. Ignition Switch 'PREHEAT'

11. The generator's voltage meter (Figure 44) displays the 120 VAC in VOLTS. If the voltage is not within the specified frequency tolerance, use the voltage adjustment control knob (Figure 45) to increase or decrease the desired voltage.

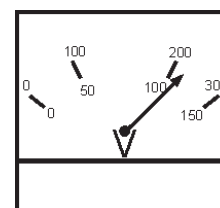

Figure 44. Voltage Meter (Volts)

DCA-25SSIU — GENERATOR START-UP PROCEDURE



Figure 45. Voltage Adjust Control Knob

12. The ammeter (Figure 46) will indicate zero amps with no load applied. When a load is applied, this meter will indicate the amount of current that the load is drawing from the generator's alternator.

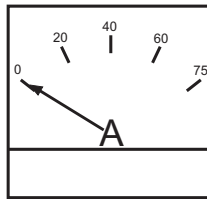

Figure 46. Ammeter (No Load)

13. The engine oil pressure gauge (Figure 47) will indicate the oil pressure (kg/cm²) of the engine. Under normal operating conditions the oil pressure is approximately 25 psi.

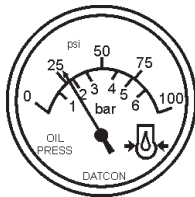

Figure 47. Oil Pressure Gauge

14. The coolant temperature gauge (Figure 48) will indicate the coolant temperature. Under normal operating conditions the coolant temperature is between 165 and 215 degrees Fahrenheit.

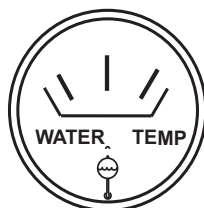

Figure 48. Coolant Temperature Gauge

15. The charging ammeter will indicate if the battery is being properly charged or if any current is being charged properly.

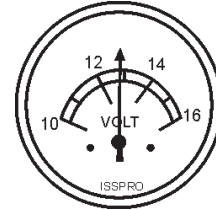

Figure 49. Charging Ammeter

16. The tachometer (Figure 50) will indicate the speed of the engine when the generator is operating. Under normal operating conditions this speed is approximately 1800 RPM's.

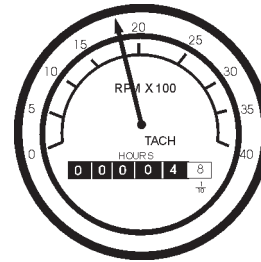

Figure 50. Engine Tachometer

17. Turn the MAIN, GFCI and LOAD circuit breakers to their ON position (Figure 51).

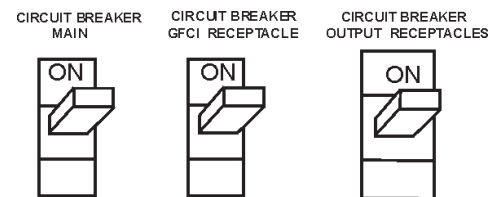

Figure 51. Main and GFCI Circuit Breakers

DCA-25SSIU — GENERATOR SHUTDOWN PROCEDURE

18. Observe the generator's ammeter (Figure 52) and verify it reads the anticipated amount of current with respect to the load. The ammeter will only display a current reading if the load is in use.

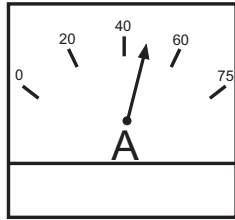

Figure 52. Ammeter (Load)

19. The generator will run until manually stopped or an abnormal condition occurs.

ENGINE SHUTDOWN

To shutdown the generator, use the following procedure:

1. Switch both the MAIN, GFCI and LOAD circuit breakers (Figure 53) to the "OFF" position.

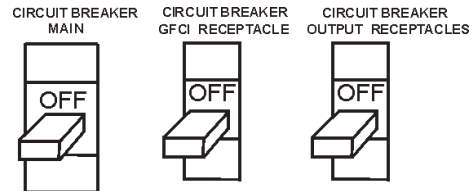

Figure 53. Main, GFCI and Load circuit breakers

2. Set the engine throttle lever to (low) position.
3. Let the engine cool by running it for 3-5 minutes with no load applied.
4. Turn the ignition key to 'STOP' (Figure 54).

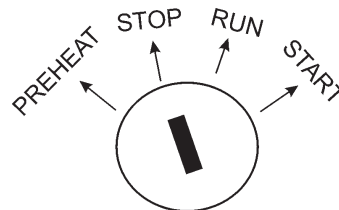

Figure 54. Ignition Switch 'STOP'

5. Remove the load from the UVW terminal strip.

General Inspection

Prior to each use, the generator should be cleaned and inspected for deficiencies. Check for loose, missing or damaged nuts, bolts or other fasteners. Also check for fuel, oil, and coolant leaks.

Engine Side (Refer to the Engine Instruction Manual)

Air Cleaner

Every 50 hours: Remove air cleaner element and clean heavy duty paper element with kerosene, or foam element with liquid detergent and hot water. Wrap foam element in a cloth and squeeze dry. For heavy duty paper element, wipe excess kerosene with towel.

Fuel Addition

Add diesel fuel (the grade may vary according to season and locations). Always pour through the mesh filter.

Removing Water from the Fuel Tank

After prolonged use, water and other impurities accumulate in the bottom of the tank. Occasionally remove the drain cock and drain the contents. During cold weather, the more empty volume inside the tank, the easier it is for water to condense. This can be reduced by keeping the tank full as much as possible.

Air Removal

If air enters the fuel injection system of a diesel engine, starting becomes impossible. After running out of fuel, or after disassembling the fuel system, bleed the system according to the following procedure.

To restart after running out of fuel, turn the switch to the "ON" position for 15-30 seconds. Try again, if needed. This unit is equipped with an automatic air bleeding system.

Service Daily

If the engine is operating in very dusty or dry grass conditions, a clogged air cleaner will result. This can lead to a loss of power, excessive carbon buildup in the combustion chamber in high fuel consumption.

Cleaning the Fuel Strainer

Clean the fuel strainer if it contains dust or water. Remove dust or water in the strainer cap and wash it in gasoline. Securely fasten the fuel strainer cap so that fuel will not leak. Check the fuel strainer every 200 hours of operation or once a month.

Check Oil Level

Check the crankcase oil level prior to each use, or when the fuel tank is filled. Insufficient oil may cause severe damage to the engine. Make sure the generator is level. The oil level must be between the two notches on the dipstick as shown in Figure 31, page 39.

Replacing Oil Filter

- Detach the oil filter cartridge with a filter wrench.
- Apply a film of oil to the gasket for the cartridge.
- Screw in the cartridge by hand. When the gasket is in contact with the seal surface, tighten the cartridge one or two more times by hand.
- After the oil cartridge has been replaced, the engine oil will drop slightly. Run the engine for a while and check for leaks before adding more oil if needed. Clean excessive oil from engine.

Replacing Fuel Filter

- Replace the fuel filter cartridge with new one every 400 hours or so.
- Apply fuel oil thinly over the gasket and hand-tighten the cartridge into position.
- Vent any air.

Flushing Out Radiator and Replacing Coolant

- Open both cocks located at the crankcase side and at the lower part of the radiator and drain coolant. Open the radiator cap while draining. Remove the overflow tank and drain.
- Check hoses for softening and kinks. Check clamps for signs of leakage.
- Flush the radiator by running clean tap water through radiator until signs of rust and dirt are removed. **DO NOT** clean radiator core with any objects, such as a screwdriver.
- Tighten both cocks and replace the overflow tank.
- Replace with coolant (see page 40, Table 12 for mixture).
- Close radiator cap tightly.

CAUTION :



Allow engine to cool when flushing out radiator. Flushing the radiator while hot will damage radiator.

Generator Storage

For storage of the generator for over 30 days, the following is required:

- Drain the fuel tank completely.
- Completely drain the oil from the crankcase and refill with fresh oil.
- Clean all external parts of the generator with a cloth.
- Cover the generating set and store in a clean, dry place.

INSPECTION / MAINTENANCE		10 Hrs DAILY	250 Hrs	500 Hrs	1000 Hrs
ENGINE	Check Engine Fluid Levels	X			
	Check Air Cleaner	X			
	Check Battery Acid Level	X			
	Check Fan Belt Condition	X			
	Check for Leaks	X			
	Check for Loosening of Parts	X			
	Replace Engine Oil and Filter * ¹		X		
	Clean Air Filter		X		
	Drain Bottom of Fuel Tank		X		
	Clean Unit, Inside and Outside		X		
	Change Fuel Filter * ²			X	
	Clean Radiator and Check Coolant Protection Level			X	
	Replace Air Filter Element				X
	Check all Hoses and Clamps				X
Clean Inside of Fuel Tank				X	
GENERATOR	Measure Insulation Resistance Over 3M ohms		X		

*¹ Replace engine oil and filter at 100 hours, first time only.

*² Replace fuel filter at 250 Hours, first time only.

DCA-25SSIU — GENERATOR WIRING DIAGRAM

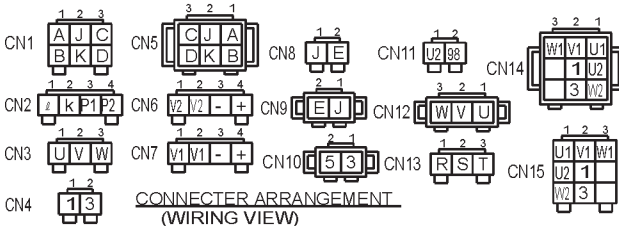
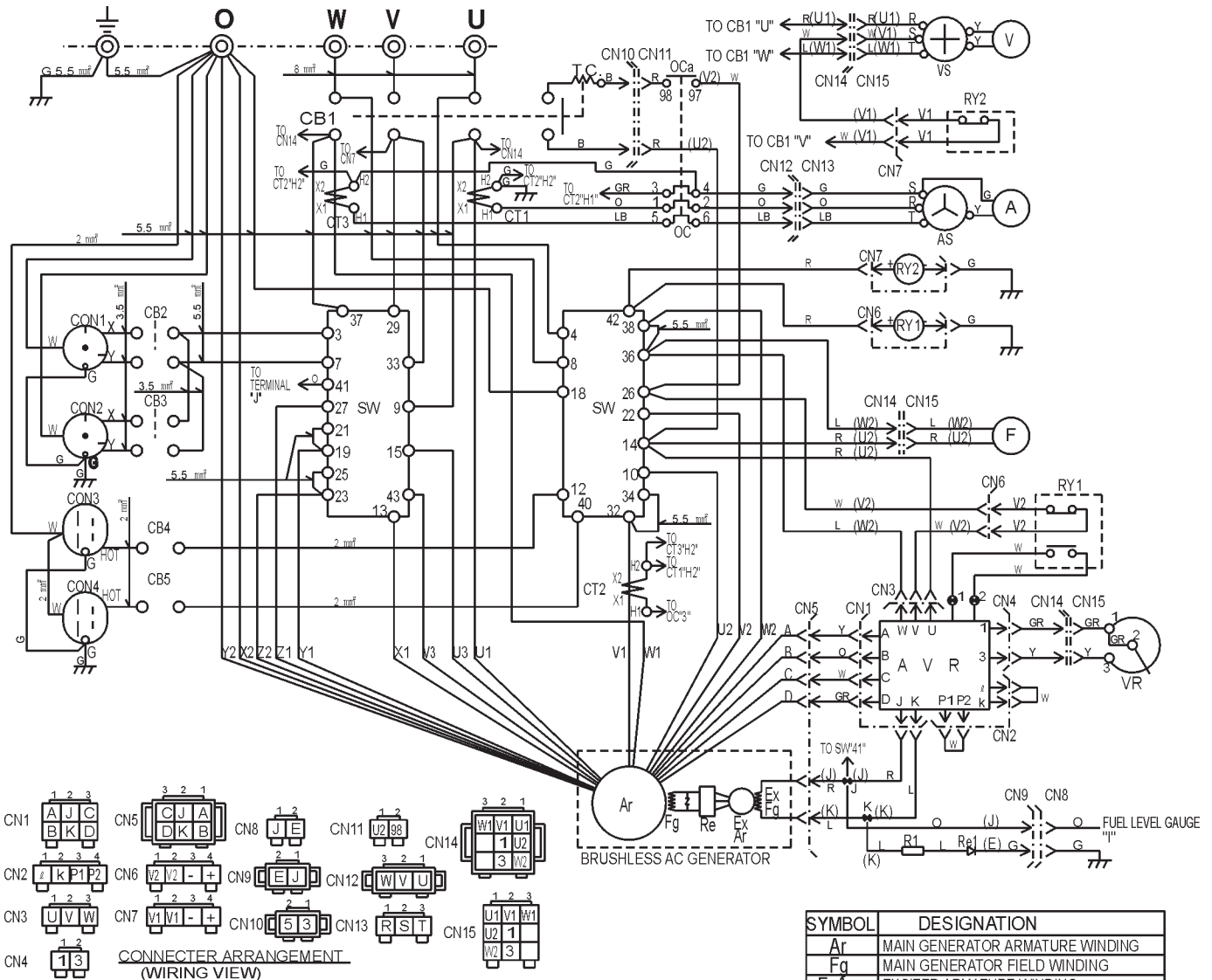

COLOR CODE			
WIRE COLOR	WIRE COLOR	WIRE COLOR	WIRE COLOR
B	BLACK	R	RED
L	BLUE	W	WHITE
BR	BROWN	Y	YELLOW
G	GREEN	LB	LIGHT BLUE
GR	GRAY	LG	LIGHT GREEN
V	VIOLET	O	ORANGE
P	PINK		

Notice
1. No designation lead size : 1.25mm²

SYMBOL	DESIGNATION
Ar	MAIN GENERATOR ARMATURE WINDING
Fg	MAIN GENERATOR FIELD WINDING
ExAr	EXCITER ARMATURE WINDING
ExFg	EXCITER FIELD WINDING
Re	RECTIFIER
AVR	AUTOMATIC VOLTAGE REGULATOR
VR	VOLTAGE REGULATOR (RHEOSTAT)
CT 1,2,3	CURRENT TRANSFORMER
AS	CHANGE-OVER SWITCH, AMMETER
A	AC, AMMETER
VS	CHANGE-OVER SWITCH, VOLTMETER
V	AC, VOLTMETER
F	FREQUENCY METER
CB1	CIRCUIT BREAKER
CB2,3	CIRCUIT BREAKER
CB4,5	CIRCUIT BREAKER
CN1,2	RECEPTACLE
CN3,4	RECEPTACLE
OC	OVER CURRENT RELAY
SW	SELECTOR SWITCH
RY1,2	RELAY UNIT
R1	RESISTOR
Re1	RECTIFIER
● J, K	TERMINAL

DCA-25SSIU — ENGINE WIRING DIAGRAM

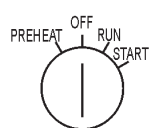
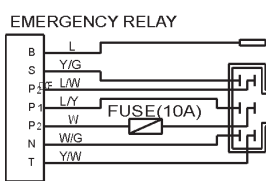
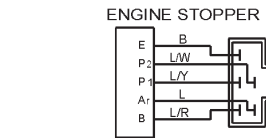
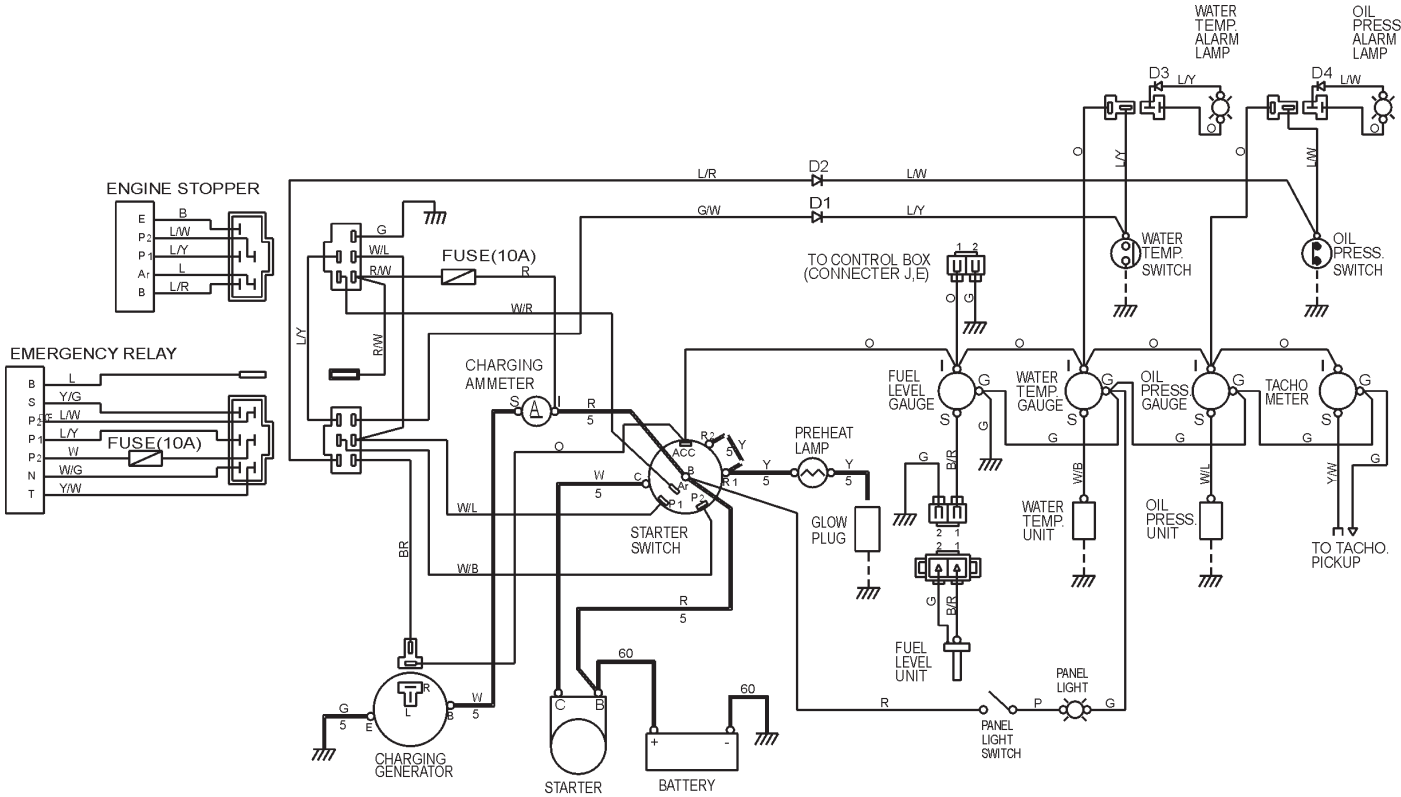

	KEY CONNECTION DIAGRAM						
	B	R 1	ACC	R 2	C	A r	P 1 P 2
OFF	○						○ ○
PREHEAT	○	○					○ ○
RUN	○		○				○ ○
START	○			○	○		○ ○

CONNECTOR: view from inserting wire side

WIRE SIZE	COLOR CODE	
60: 60 mm ²	WIRE COLOR	WIRE COLOR
5: 5 mm ²	B BLACK	R RED
No. 1.25 mm ²	L BLUE	W WHITE
	BR BROWN	Y YELLOW
	G GREEN	LB LIGHT BLUE
	GR GRAY	LG LIGHT GREEN
	V VIOLET	O ORANGE
	P PINK	WIRE COLOR LINE COLOR

DCA-25SSIU — TROUBLESHOOTING (ENGINE)

Practically all breakdowns can be prevented by proper handling and maintenance inspections, but in the event of a breakdown, use the tables shown for

diagnosis based on the Engine Troubleshooting (Table 14). If the problem cannot be remedied, consult our company's business office or service plant.

TABLE 14. ENGINE TROUBLESHOOTING

SYMPTOM	POSSIBLE PROBLEM	SOLUTION
Engine does not start.	No fuel?	Replenish fuel.
	Air in the fuel system?	Bleed system.
	Water in the fuel system?	Remove water from fuel tank.
	Fuel pipe clogged?	Clean fuel pipe.
	Fuel filter clogged?	Clean or change fuel filter.
	Excessively high viscosity of fuel or engine oil at low temperature?	Use the specified fuel or engine oil.
	Fuel with low cetane number?	Use the specified fuel.
	Fuel leak due to loose injection pipe retaining nut?	Tighten nut.
	Incorrect injection timing?	Adjust.
	Fuel cam shaft worn?	Replace.
	Injection nozzle clogged?	Clean injection nozzle.
	Injection pump malfunctioning?	Repair or replace.
	Seizure of crankshaft, camshaft, piston, cylinder liner or bearing?	Repair or replace.
	Compression leak from cylinder?	Replace head gasket, tighten cylinder head bolt, glow plug and nozzle holder.
	Improper valve timing?	Correct or replace timing gear.
Piston ring and liner worn?	Replace.	
Excessive valve clearance?	Adjust.	
Starter does not run.	Starter malfunctioning?	Repair or replace.
	Wiring disconnected?	Connect wiring.

TABLE 14. ENGINE TROUBLESHOOTING (CONTINUED)

SYMPTOM	POSSIBLE PROBLEM	SOLUTION
Engine revolution is not smooth.	Fuel filter clogged or dirty?	Clean or change.
	Air cleaner clogged?	Clean or change.
	Fuel leak due to loose injection pipe retaining nut?	Tighten nut.
	Injection pump malfunctioning?	Repair or replace.
	Incorrect nozzle opening pressure?	Adjust.
	Injection nozzle stuck or clogged?	Repair or replace.
	Fuel over flow pipe clogged?	Clean.
	Governor malfunctioning?	Repair.
Either white or blue exhaust gas is observed.	Excessive engine oil?	Reduce to the specified level.
	Piston ring and liner worn or stuck?	Repair or replace.
	Incorrect injection timing?	Adjust.
	Deficient compression?	Adjust top clearance.
Either black or dark gray exhaust gas is observed.	Overload?	Lessen the load.
	Low grade fuel used?	Use the specified fuel.
	Fuel filter clogged?	Clean or change.
	Air cleaner clogged?	Clean or change.
	Deficient nozzle injection?	Repair or replace the nozzle.
Deficient output.	Incorrect injection timing?	Adjust.
	Engine's moving parts seem to be seizing?	Repair or replace.
	Uneven fuel injection?	Repair or replace the injection pump.
	Deficient nozzle injection?	Repair or replace the nozzle.
	Compression leak?	Replace head gasket, tighten cylinder head bolt, glow plug and nozzle holder.

DCA-25SSIU — TROUBLESHOOTING (GENERATOR/ENGINE)

Practically all breakdowns can be prevented by proper handling and maintenance inspections, but in the event of a breakdown, use the tables shown for diagnosis based on the Engine and Radiator Troubleshooting (Table15). If the problem cannot be remedied, consult our company's business office or service plant.

TABLE 15. GENERATOR TROUBLESHOOTING

SYMPTOM	POSSIBLE PROBLEM	SOLUTION
No Voltage Output	AC Voltmeter defective?	Check output voltage using a voltmeter.
	Is wiring connection loose?	Check wiring and repair.
	Is AVR defective?	Replace if necessary.
	Defective Rotating Rectifier?	Check and replace.
Low Voltage Output	Is engine speed correct?	Turn engine throttle lever to "High".
	Is wiring connections loose?	Check wiring and repair.
	Defective AVR?	Replace if necessary.
High Voltage Output	Is wiring connections loose?	Check wiring and repair.
	Defective AVR?	Replace if necessary.
Circuit Breaker Tripped	Short Circuit in load?	Check load and repair.
	Over current?	Confirm load requirements and reduce.
	Defective circuit breaker?	Check and replace.
	Over current Relay actuated?	Confirm load requirement and replace.

EXPLANATION OF CODE IN REMARKS COLUMN

The following section explains the different symbols and remarks used in the Parts section of this manual. Use the help numbers found on the back page of the manual if there are any questions.

NOTICE

The contents and part numbers listed in the parts section are subject to change **without notice**. Multiquip does not guarantee the availability of the parts listed.

SAMPLE PARTS LIST

NO.	PART NO.	PART NAME	QTY.	REMARKS
1	12345	BOLT.....	1	INCLUDES ITEMS W/%
2%		WASHER, 1/4 IN.....		NOT SOLD SEPARATELY
2%	12347	WASHER, 3/8 IN....	1	MQ-45T ONLY
3	12348	HOSE	A/R	MAKE LOCALLY
4	12349	BEARING	1	S/N 2345B AND ABOVE

NO. Column

Unique Symbols — All items with same unique symbol

(@, #, +, %, or >) in the number column belong to the same assembly or kit, which is indicated by a note in the “Remarks” column.

Duplicate Item Numbers — Duplicate numbers indicate multiple part numbers, which are in effect for the same general item, such as different size saw blade guards in use or a part that has been updated on newer versions of the same machine.

NOTICE

When ordering a part that has more than one item number listed, check the remarks column for help in determining the proper part to order.

PART NO. Column

Numbers Used — Part numbers can be indicated by a number, a blank entry, or TBD.

TBD (To Be Determined) is generally used to show a part that has not been assigned a formal part number at the time of publication.

A blank entry generally indicates that the item is not sold separately or is not sold by Multiquip. Other entries will be clarified in the “Remarks” Column.

QTY. Column

Numbers Used — Item quantity can be indicated by a number, a blank entry, or A/R.

A/R (As Required) is generally used for hoses or other parts that are sold in bulk and cut to length.

A blank entry generally indicates that the item is not sold separately. Other entries will be clarified in the “Remarks” Column.

REMARKS Column

Some of the most common notes found in the “Remarks” Column are listed below. Other additional notes needed to describe the item can also be shown.

Assembly/Kit — All items on the parts list with the same unique symbol will be included when this item is purchased.

Indicated by:

“INCLUDES ITEMS W/(unique symbol)”

Serial Number Break — Used to list an effective serial number range where a particular part is used.

Indicated by:

“S/N XXXXX AND BELOW”

“S/N XXXX AND ABOVE”

“S/N XXXX TO S/N XXX”

Specific Model Number Use — Indicates that the part is used only with the specific model number or model number variant listed. It can also be used to show a part is NOT used on a specific model or model number variant.

Indicated by:

“XXXXX ONLY”

“NOT USED ON XXXX”

“Make/Obtain Locally” — Indicates that the part can be purchased at any hardware shop or made out of available items. Examples include battery cables, shims, and certain washers and nuts.

“Not Sold Separately” — Indicates that an item cannot be purchased as a separate item and is either part of an assembly/kit that can be purchased, or is not available for sale through Multiquip.

DCA-25SSIU W/ISUZU C240 DIESEL ENGINE 1 TO 3 UNITS

Qty.	P/N	Description
10	0602046356	CIRCUIT BREAKER
20	X132400150	FUEL FILTER
20	8970246071	OIL FILTER
5	5136710400	FAN BELT
1	8943768300	WATER PUMP
2	9136140430	WATER PUMP GASKET
2	1823100080	STARTER SWITCH
5	KEYISUZUF	STARTER SWITCH KEY
3	0602122272	OIL SENDING UNIT
2	5137700221	THERMOSTAT
2	X137130020	THERMOSTAT GASKET
2	0602014504	RADIATOR HOSE (UPPER)
2	0602014601	RADIATOR HOSE (LOWER)
1	0605505070	FUEL CAP
8	9825119783	GLOW PLUGS
2	5153110060	INJECTOR NOZZLES
1	5825500422	EMERGENCY RELAY
1	5819000200	STOPPER ENGINE
1	5812003411	ALTERNATOR
1	8944532120	STARTER
1	0601820671	AUTOMATIC VOLTAGE REGULATOR
1	0601808810	MAIN CIRCUIT BREAKER
1	0601840073	VOLTAGE REGULATOR (RHEOSTAT)
1	M1923100004	SELECTOR SWITCH
1	47130106	SELECTOR SWITCH KNOB
2	0601810245	PREHEAT LAMP BULB

NOTE

**Part number on this Suggested Spare
Parts list may supercede/replace the
P/N shown in the text pages of this
book.**

DCA-25SSIU --- GENERATOR ASSY.

GENERATOR ASSY.

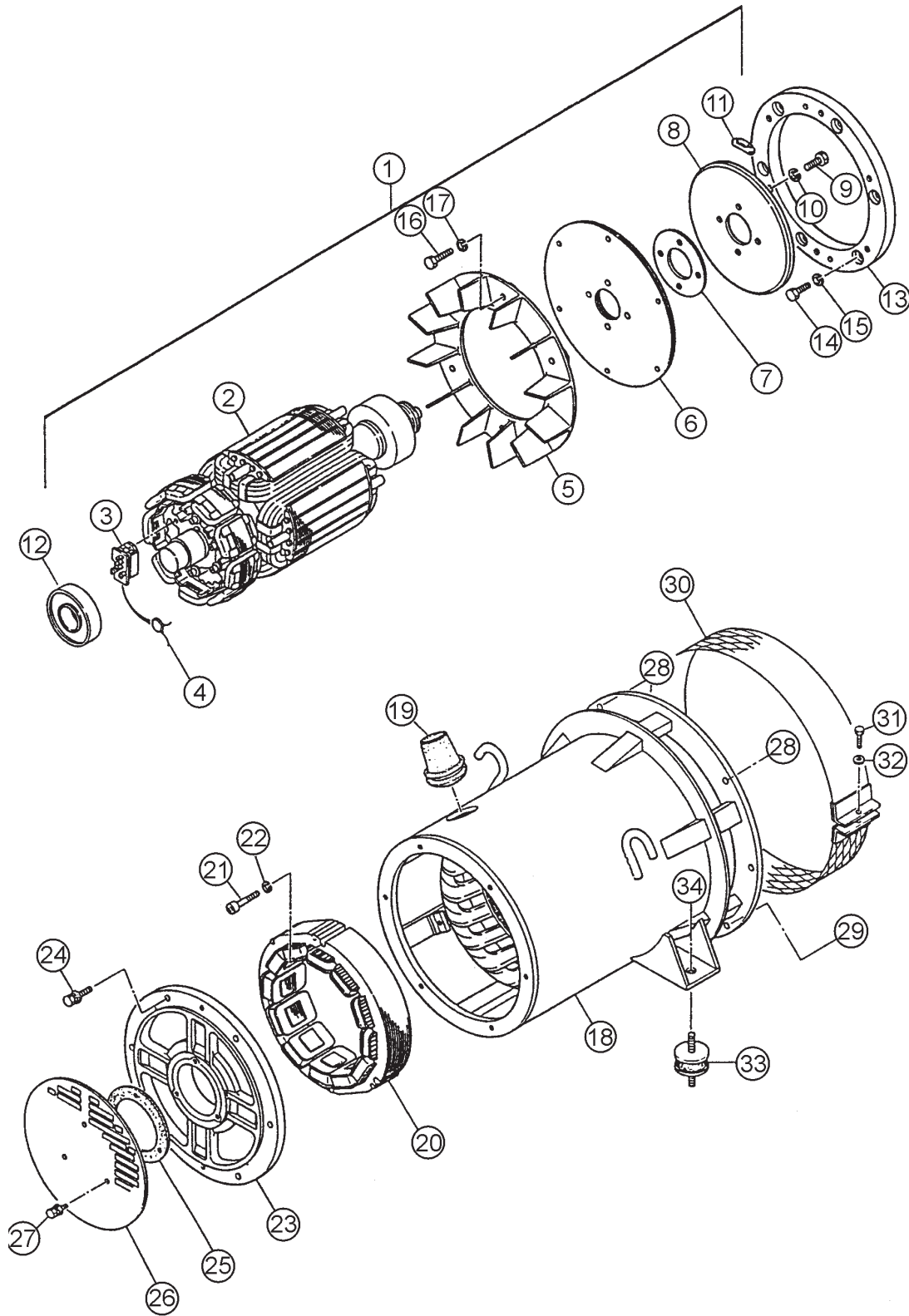

DCA-25SSIU --- GENERATOR ASSY.

GENERATOR ASSY.

<u>NO.</u>	<u>PART NO.</u>	<u>ITEM</u>	<u>QTY.</u>	<u>REMARKS</u>
1	8351000002	ROTOR ASSY.	1	
2		FIELD ASSY.	1	
3	7961025004	RECTIFIER	1	
4	0601822630	SURGE ABSORBER	1	TNR26G471K
5	8001070003	FAN	1	
6	8351611004	COUPLING DISK	2	
7	8351612004	WASHER, COUPLING HUB	1	
8	8351615003	BALANCING PLATE	1	
9	0105091025	HEX. HEAD BOLT	4	REPLACES 0010310025
10	0042610000	LOCK WASHER	4	
11	0601000209	BALANCING WEIGHT KIT	1	
12	042006308	BEARING	1	6308DDUC3; REPLACES 0071906308
13	8351614003	COUPLING RING	1	REPLACES M1163400103
14	0012108025	HEX. HEAD BOLT	6	
15	0042508000	LOCK WASHER	6	
16	0012108035	HEX. HEAD BOLT	6	
17	0042508000	LOCK WASHER	6	
18	B1130100203	STRATOR ASSY.	1	
19	0845041904	GROMMET	1	
20	8351350103A	FIELD ASSY. EXCITER	1	REPLACES 8351350103
21	0016008045	HEX. SOCKET HAD CAP SCREW	3	
22	0042508000	LOCK WASHER	3	
23	8351315003	END BRACKET	1	
24	011208035	HEX. HEAD BOLT	6	REPLACES 0017108035
25	8351312004	PACKING	1	
26	8351331004	COVER, SUCTION	1	
27	0017106016	HEX. HEAD BOLT	3	
28	0105051045	HEX. HEAD BOLT	2	S/N7100001 TO 7102574; REPLACES 0012110045
	0012310045	HEX. HEAD BOLT	2	S/N7102575~
	0207010000	HEX. NUT	2	
	030210250	LOCK WASHER	2	S/N7100001 TO 7102574; REPLACES 0042510000
	020310080	HEX.NUT	2	REPLACES 0030010000
29	0012110040	HEX. HEAD BOLT	4	S/N7100001 TO 7102574
	0012310040	HEX. HEAD BOLT	4	S/N7102575~
	0207010000	HEX. NUT	4	
	030210250	LOCK WASHER	4	S/N7100001 TO 7102574; REPLACES 0042510000
30	8351332004	COVER, FAN	1	
31	0010106030	HEX.HEAD BOLT	1	
32	952404470	PLAIN WASHER	1	REPLACES 0041206000
33	0605000008	RUBBER SUSPENSION	2	EA1009
34	0030012000	HEX NUT	2	
	0040012000	LOCK WASHER	2	
	031112230	PLAIN WASHER	2	REPLACES 0041212000

DCA-25SSIU --- CONTROL BOX ASSY.

CONTROL BOX ASSY.

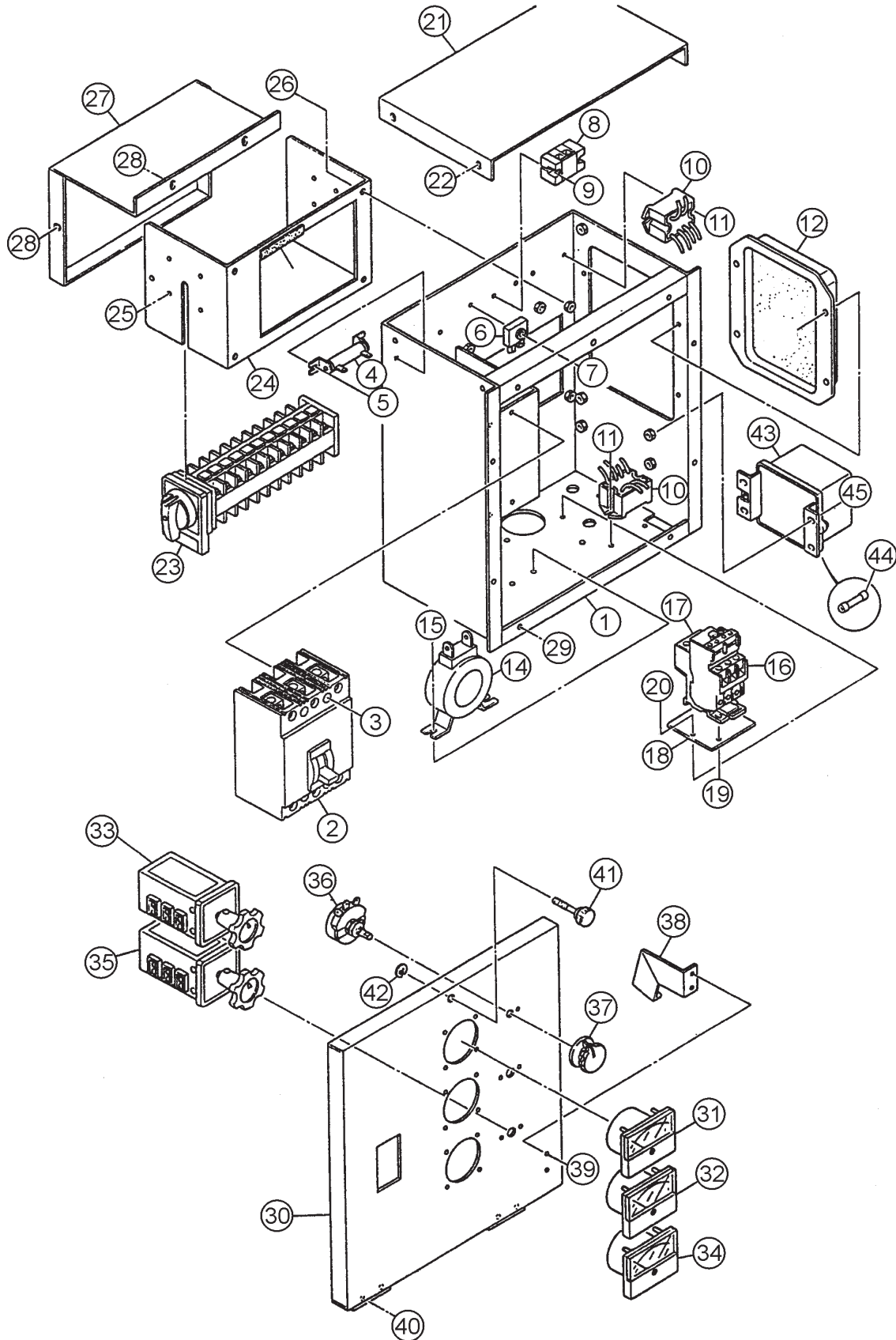

DCA-25SSIU --- CONTROL BOX ASSY.

CONTROL BOX ASSY.

<u>NO.</u>	<u>PART NO.</u>	<u>ITEM</u>	<u>QTY.</u>	<u>REMARKS</u>
	M1246700514	WIRE HARNESS, GENERATOR	1	UP TO S/N7106114
	M1246700524	WIRE HARNESS, GENERATOR	1	S/N7106115~
1	M1213000202	CONTROL BOX	1	S/N7100001 TO 7102144
	M1213000212	CONTROL BOX	1	S/N7102145 TO 7102314
	M1213000222	CONTROL BOX	1	S/N7102315~
2	0601808810	CIRCUIT BREAKER	1	FAF340601021 3P 60A; UP TO S/N7106114
	0601808820	CIRCUIT BREAKER	1	S/N7106115~
3	021005080	MACHINE SCREW	4	
4	0601842384	RESISTOR	1	GG20W 50 OHM
5	0027104010	MACHINE SCREW	2	
6	0601821370	RECTIFIER	3	DE4503; REPLACES 0601823240
7	0021004040	MACHINE SCREW	1	
	0040004000	LOCK WASHER	1	
	031104080	PLAIN WASHER	1	REPLACES 0041204000
8	0601815925	TERMINAL BOARD	1	202HB SP
9	0027104020	MACHINE SCREW	2	
10	0601823863	RELAY UNIT	2	MSA9013A
11	0021304015	MACHINE SCREW	4	REPLACES 0027104015
12	0601820671	AUTOMATIC VOLTAGE REGULATOR	1	NTA5A2DB
13	0027105010	MACHINE SCREW	4	S/N7100001 TO 7102574
	0027105015	MACHINE SCREW	4	S/N7102575~
14	0601806115	CURRENT TRANSFORMER	3	812943 50/5A
15	011808015	MACHINE SCREW	6	REPLACES 0027106015
16	0601820845	OVER CURRENT RELAY	1	LR2D1308
17	0601820846	OVER CURRENT RELAY	1	LR7D1064
18	M1260600004	FITTING BRACKET	1	S/N7100001 TO 7102314
19	0021304015	MACHINE SCREW	2	S/N7100001 TO 7102314; REPLACES 0027104015
	0030004000	HEX. NUT	2	REPLACES 0207004000
20	0027104010	MACHINE SCREW	2	
21	M1213500203	CONTROL BOX COVER	1	
22	011106015	HEX. HEAD BOLT	4	REPLACES 0016906015
23	M1923100004	SELECTOR SWITCH	1	VY40
24	M1213600104	SWITCH BRACKET	1	S/N7100001 TO 7102144

ADD THE FOLLOWING DIGITS AFTER THE PART NUMBER
WHEN ORDERING ANY PAINTED PANEL TO INDICATE

COLOR OF UNIT:

1-ORANGE	5-BLACK
2-WHITE	6-CATERPILLAR YELLOW
3-SPECTRUM GRAY	7-CATO GOLD
4-SUNBELT GREEN	8-RED

THE SERIAL NUMBER MAY BE REQUIRED.

DCA-25SSIU --- CONTROL BOX ASSY.

CONTROL BOX ASSY.

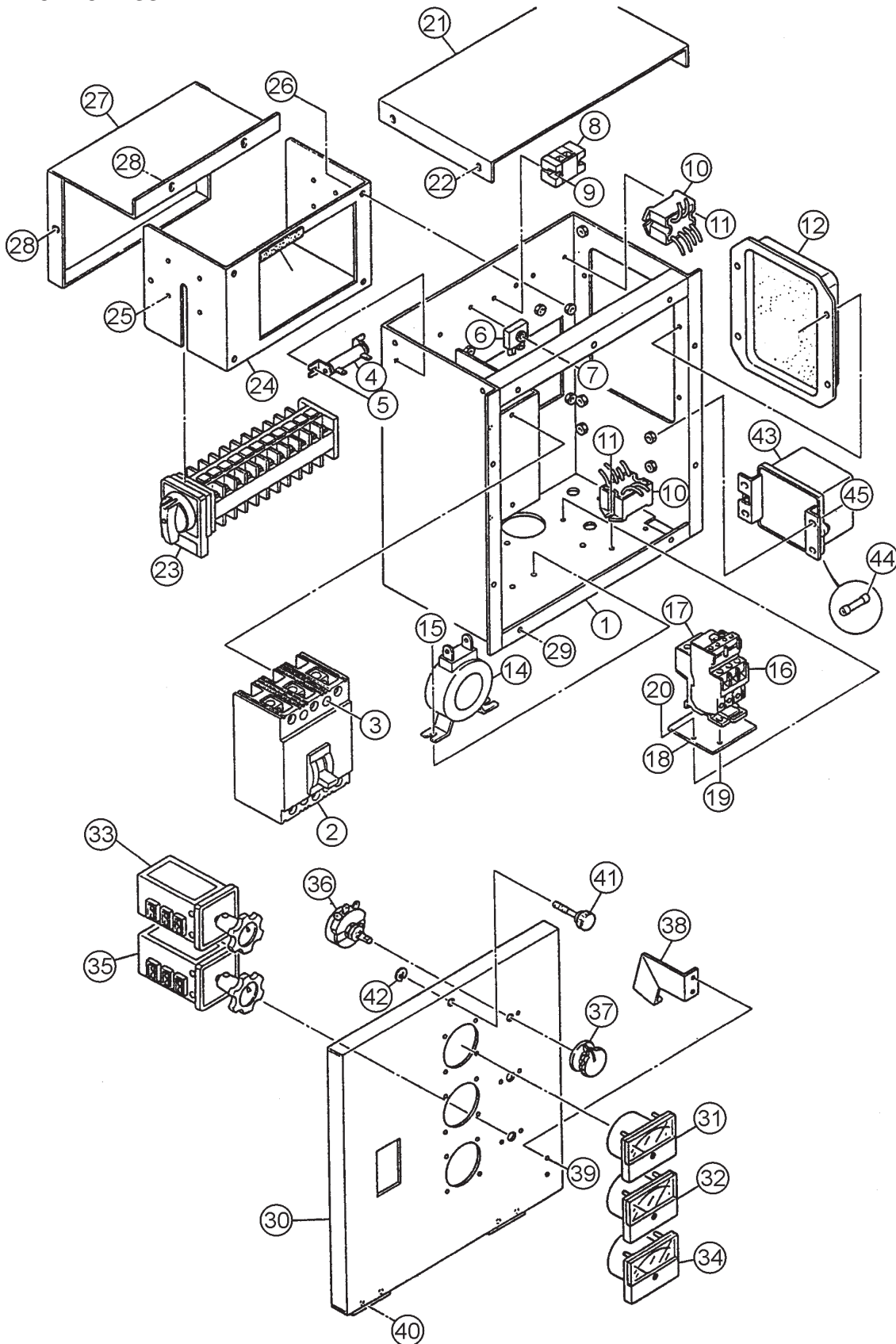

DCA-25SSIU --- CONTROL BOX ASSY.

CONTROL BOX ASSY.

NO.	PART NO.	ITEM	QTY.	REMARKS
	M1213600114	SWITCH BRACKET	1	S/N7102145
25	0027103010	MACHINE SCREW	4	
26	011106015	HEX. HEAD BOLT	4	REPLACES 0016906015
27	M1213600004	SWITCH COVER	1	S/N7100001 TO 7102144
	M1213600014	SWITCH COVER	1	S/N7102145~
28	011106015	HEX. HEAD BOLT	4	S/N7100001 TO 7102059; REPLACES 0016906015
	011106015	HEX. HEAD BOLT	3	S/N7102059~; REPLACES 0016906015
29	0016906015	HEX. HEAD BOLT	8	
	0040506000	TOOTHED WASHER	1	
30	M1223000203	CONTROL PANEL	1	
31	0601807630	FREQUENCY METER,264250DJDJ9;	1	REPLACES 0601807696 UP TO S/N7105234
	0601807641	FREQUENCY METER, FCF6 45-65HZ 240V ...	1	FROM S/N7105235~
32	0601808952	AC AMMETER,260240LSNT1	1	REPLACES 0601808991; UP TO S/N7105234
32	0601808985	AC AMMETER, ACF60-50A,0-100A/5A	1	FROM S/N7105235~
33	0601801040	CHANGE-OVER SWITCH, AMMETER	1	SL2AS
34	0601806813	AC VOLTMETER,260244SJSJ1;	1	REPLACES 0601806896 UP TO S/N7105234
	0601806859	AC VOLTMETER, SCF6 0-600V	1	FROM S/N7105235~
35	0601801041	CHANGE-OVER SWITCH VOLTMETER	1	SL2VS
36	0601840073	RHEOSTAT (VOLTAGE REGULATOR)	1	RA20A2SE102BJ 2W 1K OHM
37	0601840121	KNOB	1	
38	M122310004	STOPPER	1	
39	0027105015	MACHINE SCREW	2	S/N7100001 TO 7102674
	0027105010	MACHINE SCREW	2	S/N7102675~
40	0027105015	MACHINE SCREW	4	S/N7100001 TO 7102674
	0027105010	MACHINE SCREW	4	S/N7102675~
41	M9220100004	SET SCREW	1	
42	0080200007	SNAP RING	1	
43	5825500422	EMERGENCY RELAY	1	REPLACES 0602200400
44	06018020132	FUSE	1	
45	011106015	HEX. HEAD BOLT	4	REPLACES 0016906015
46	0330000160	EDGING	2	S/N7100131~

ADD THE FOLLOWING DIGITS AFTER THE PART NUMBER
 WHEN ORDERING ANY PAINTED PANEL TO INDICATE
 COLOR OF UNIT:
 1-ORANGE 5-BLACK
 2-WHITE 6-CATERPILLAR YELLOW
 3-SPECTRUM GRAY 7-CATO GOLD
 4-SUNBELT GREEN 8-RED

 THE SERIAL NUMBER MAY BE REQUIRED.

DCA-25SSIU ENGINE AND RADIATOR ASSY.

ENGINE AND RADIATOR ASSY.

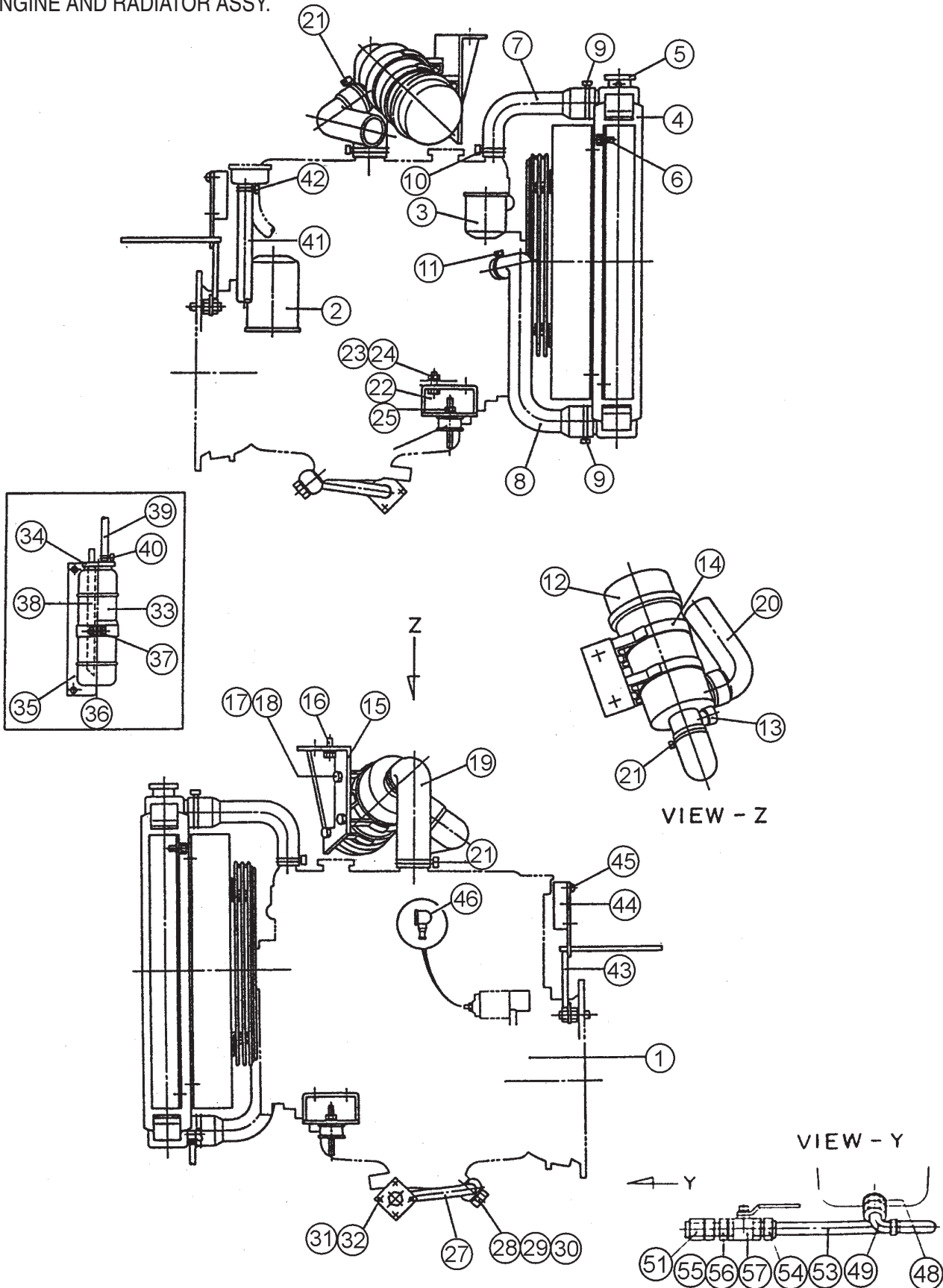

DCA-25SSIU ENGINE AND RADIATOR ASSY.

ENGINE AND RADIATOR ASSY.

<u>NO.</u>	<u>PART NO.</u>	<u>ITEM</u>	<u>QTY.</u>	<u>REMARKS</u>
1	M1923200004A	ENGINE	1	ISUZU QD60(C240) S/N7100001 TO 7102685
	M1925200004	ENGINE	1	ISUZU QD60(C240) S/N7102686~
	5136710400	FAN BELT	1	REPLACES 0602011401
2	8970246071	CARTRIDGE, OIL FILTER	1	REPLACES 0602041212
3	X132400150	CARTRIDGE, FUEL FILTER	1	REPLACES 0602042510
4	0602011996	RADIATOR	1	C2810010000
5	0602011065	CAP	1	C89C0115010
6	011008020	HEX. HEAD BOLT	6	REPLACES 0016908020
7	0602014504	RADIATOR HOSE, UPER	1	S/N7100001 TO 7101005
	M1310500103	RADIATOR HOSE, UPPER	1	S/N7101006~
8	06020146010	RADIATOR HOSE, LOWER	1	S/N7100001 TO 7101005
	M1310500203	RADIATOR HOSE, LOWER	1	S/N7101006~
9	0602014334	HOSE BAND	2	S/N7100001 TO 7100050
	0605515147	HOSE BAND	2	S/N7100051~
10	0602014332	HOSE BAND	1	S/N7100001 TO 7100050
	0605515149	HOSE BAND	1	S/N7100051~
11	0602014333	HOSE BAND	1	S/N7100001 TO 7100050
	0605515149	HOSE BAND	1	S/N710051~
12	0602046231	AIR CLEANER	1	S/N7100001 TO S/N7104749
	0602046580	AIR CLEANER	1	S/N7104750~
	0602046356	ELEMENT, AIR CLEANER	1	S/N7100001 TO S/N7104749;
	0602046321	ELEMENT, AIR CLEANER	1	S/N7104750~
13	0602040650	INDICATOR, AIR CLEANER	1	S/N7100001 TO S/N7104749
	0602040651	INDICATOR, AIR CLEANER	1	S/N7104750~
14	0602040593	BAND, AIR CLEANER	2	S/N7100001 TO 7104749
	0602040552	BAND, AIR CLEANER	1	S/N7104750~
15	M1373200003	BRACKET, AIR CLEANER	1	S/N7100001 TO S/N7104749
16	012210025	HEX. HEAD BOLT	2	S/N7100001 TO S/N7104749;
				REPLACES 0016910025
17	011008020	HEX. HEAD BOLT	4	S/N7100001 TO 7100050;
				REPLACES 0016908020
18	0013003008	HEX. HEAD BOLT	4	S/N7100051 TO S/N7104749
	0016908030	HEX. HEAD BOLT	2	S/N7104750~
19	020108060	HEX. NUT	4	S/N7100001 TO 7100050;
				REPLACES 0207008000
	0036203000	HEX.NUT	4	S/N7100051 TO S/N7104749
	020108060	HEX.NUT	2	S/N7104750~; REPLACES 0207008000
	0043003000	LOCK WASHER	4	S/N710051 TO S/N7104749
	0043103000	PLAIN WASHER	4	S/N7100051 TO S/N7104749
	8352032303	HOSE, AIR CLEANER	1	REPLACES M1373100103
20	M137310004	HOSE, AIR CLEANER	1	
21	0605515010	HOSE BAND	3	S/N7100001 TO S/N7100050
	060551547	HOSE BAND	3	S/N7100051~
22	M1303200004	ENGINE FOOT	2	

DCA-25SSIU ENGINE AND RADIATOR ASSY.

ENGINE AND RADIATOR ASSY.

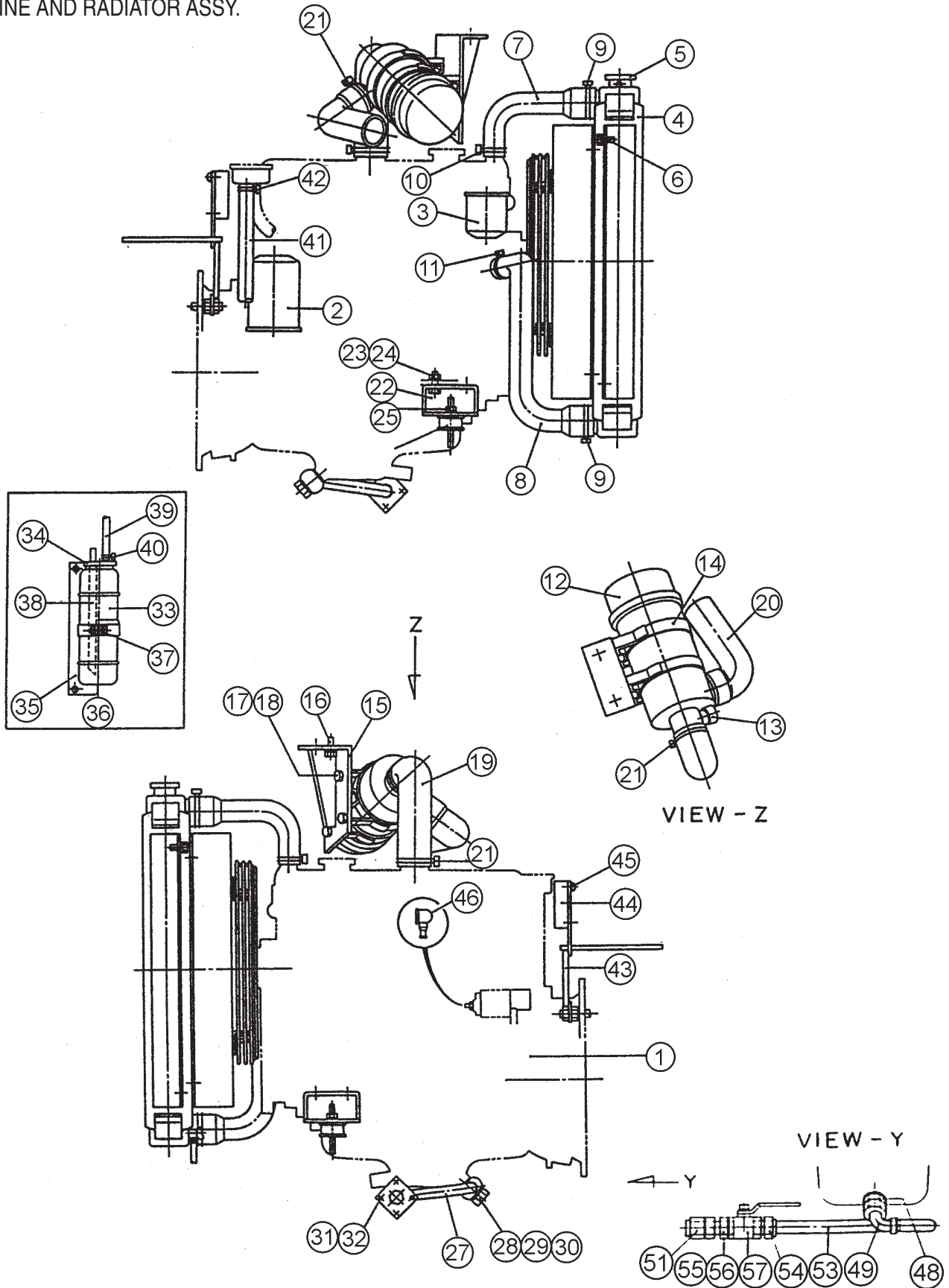

DCA-25SSIU ENGINE AND RADIATOR ASSY.

ENGINE AND RADIATOR ASSY.

<u>NO.</u>	<u>PART NO.</u>	<u>ITEM</u>	<u>QTY.</u>	<u>REMARKS</u>
23	012010030	HEX. HEAD BOLT	4	REPLACES 0017110030
24	0207010000	HEX. NUT	4	
25	060500006	RUBBER SUSPENSION	2	EA1007
26	020701000	HEX. NUT	2	
27	M1320200003	DRAIN PIPE	1	S/N7100001 TO S/N7100130
28	M1320300204	PACKING, OIL PAN SIDE	1	S/N7100001 TO S/N7100130; REPLACES M1320300204
29	9095720240	PACKING	1	S/N7100001 TO S/N7100130; REPLACES 0602021107
30	M1320300104	JOINT BOLT	1	S/N7100001 TO S/N7100130
31	011206020	HEX. HEAD BOLT	2	S/N7100001 TO S/N7100130; REPLACES 0016906020
32	0207006000	HEX. NUT	2	S/N7100001 TO S/N7100130
33	M9300000003	RESERVE TANK	1	
34	M9300100003	CAP, RESERVE TANK	1	
35	M1316100204	BRACKET, RESERVE TANK	1	
36	0229200300	RUBBER CUSHION	1	S/N7100001 TO S/N7100150
37	011206020	HEX. HEAD BOLT	1	S/N7100001 TO S/N7100150; REPLACES 0016906020
38	0199100215	HOSE	1	
39	0193601450	HOSE	1	
40	0605515106	HOSE BAND	1	S/N7100001 TO S/N7100150
41	0194500600	HOSE	1	S/N7100001 TO S/N7100150
42	0605515003	HOSE BAND	2	S/N7100001 TO S/N7100150
43	M1483600503	CLAMP BAR	1	REPLACES M1483600103
44	5819000200	ENGINE STOPPER	1	REPLACES 06022108020
	06018020132	FUSE	1	
45	011808015	MACHINE SCREW	3	REPLACES 0027106015
46	0602220621	TERMINAL COVER	1	S/N7100001 TO S/N7100150
47	0602022560	ADAPTER	1	S/N7100131~
48	M1320300304	PACKING	1	S/N7100131~
49	0602025561	90° ELBOW	1	S/N7100131~
50	0602022562	UNION	1	S/N7100131 TO S/N7104749
51	0602022792	SWIVEL	1	S/N 7100131 TO S/N7104749
52	0602021070	CAP	1	S/N 7100131~
53	0602021570	DRAIN HOSE	1	S/N 7100131 TO S/N7104749
	0269200660	DRAIN HOSE	1	S/N7104750~
54	0603306395	HOSE JOINT	1	S/N7104750~
55	0603306590	CONNECTOR	1	S/N7104750~
56	0603300285	ROCK NUT	1	S/N7104750~
57	0605511395	VALVE	1	S/N7104750~

DCA-25SSIU --- ENGINE OPERATING PANEL ASSY.

ENGINE OPERATING PANEL ASSY.

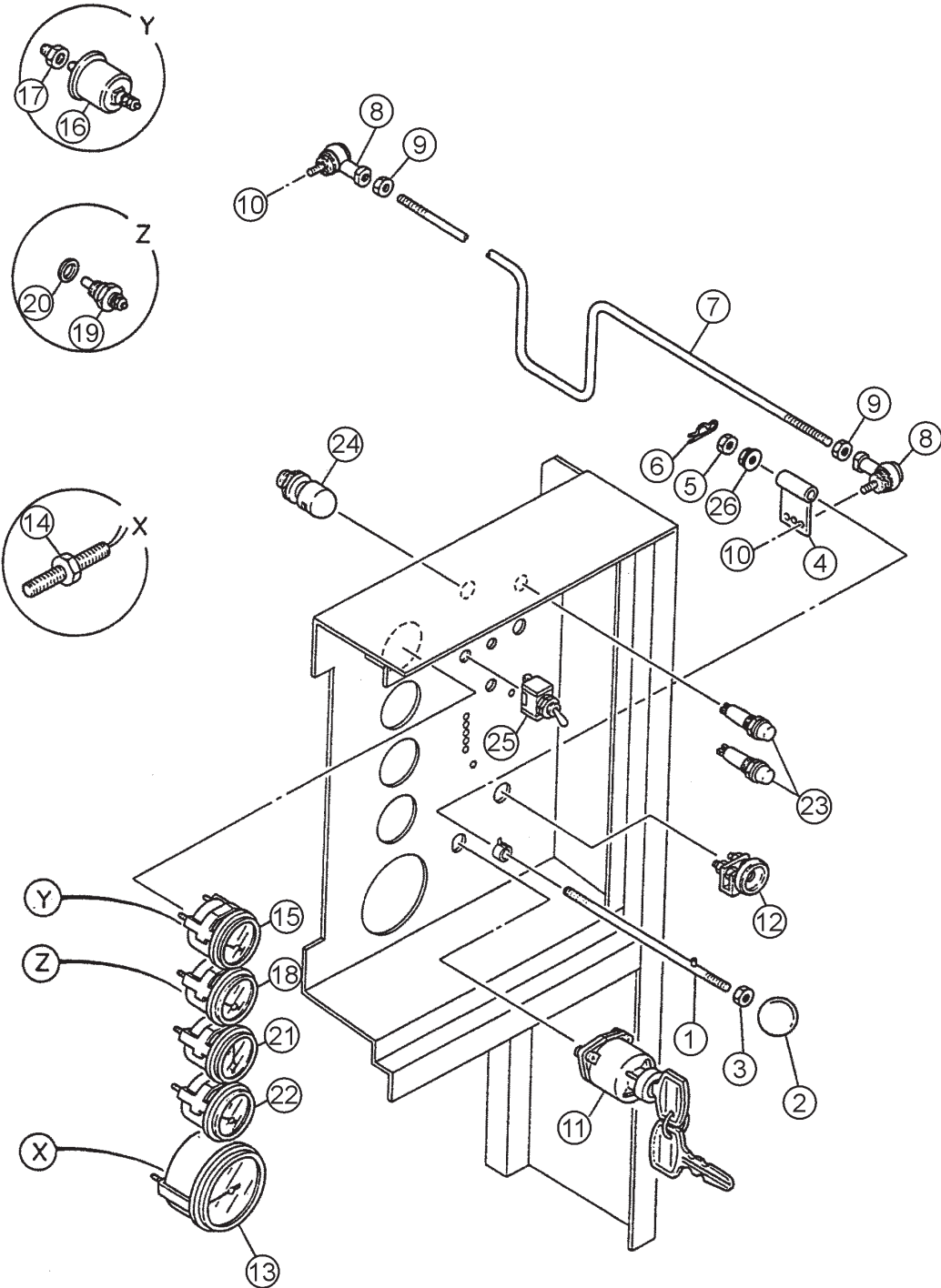

DCA-25SSIU --- ENGINE OPERATING PANEL ASSY.

ENGINE OPERATING PANEL ASSY.

<u>NO.</u>	<u>PART NO.</u>	<u>ITEM</u>	<u>QTY.</u>	<u>REMARKS</u>
	M1357200102A	WIRE HARNESS, ENGINE	1	
1	M1354300304	SLIDE LEVER	1	
2	0601840190	KNOB	1	REPLACES M9320000004
3	020108060	HEX. NUT	1	REPLACES 0036003000
4	M1354200004	BRACKET	1	ASK CUST. SVC. FOR COLOR
5	020108060	HEX. NUT	1	REPLACES 0030008000
6	0605010503	SNAP PIN	1	
7	M1354300204	GOVERNOR ROD	1	
8	0602180106	BALL JOINT	2	LHSA8DE161
9	020108060	HEX. NUT	2	REPLACES 0030008000
10	0207006000	HEX. NUT	2	
	0041206000	PLAIN WASHER	2	
11	1823100080	STARTER SWITCH	1	REPLACES 0602100004
12	8944626110	PREHEAT LAMP	1	REPLACES 0602102066
13	0602120095	TACHOMETER	1	103680
14	0602120480	PICK UP, TACHOMETER	1	7154400
15	0602122093	OIL PRESSURE GAUGE	1	100174
16	0602122272	OIL PRESSURE UNIT	1	102225; S/N7100001 TO S/N7101239; REPLACES 0602122207
17	M9200100004	ADAPTER	1	
18	0602123090	WATER TEMPERATURE GAUGE	1	100683
19	0602123201	WATER TEMPERATURE UNIT	1	0209400
20	9095720140	PACKING	1	REPLACES 0602121109
21	0602121080	CHARGING AMMETER	1	100158
22	0602128090	FUEL GAUGE	1	100176
23	0602103092	ALARM LAMP	2	PL05
	0601810245	BULB	2	E10 T10 DC18V
24	0601810141	PANEL LIGHT	1	ISUZU 9826800370
25	0601831330	SWITCH, PANEL LIGHT	1	900001
26	020108060	HEX. NUT	1	REPLACES 0207008000

ADD THE FOLLOWING DIGITS AFTER THE PART NUMBER
WHEN ORDERING ANY PAINTED PANEL TO INDICATE
COLOR OF UNIT:

1-ORANGE	5-BLACK
2-WHITE	6-CATERPILLAR YELLOW
3-SPECTRUM GRAY	7-CATO GOLD
4-SUNBELT GREEN	8-RED

THE SERIAL NUMBER MAY BE REQUIRED.

DCA-25SSIU --- OUTPUT TERMINAL ASSY.

OUTPUT TERMINAL ASSY.

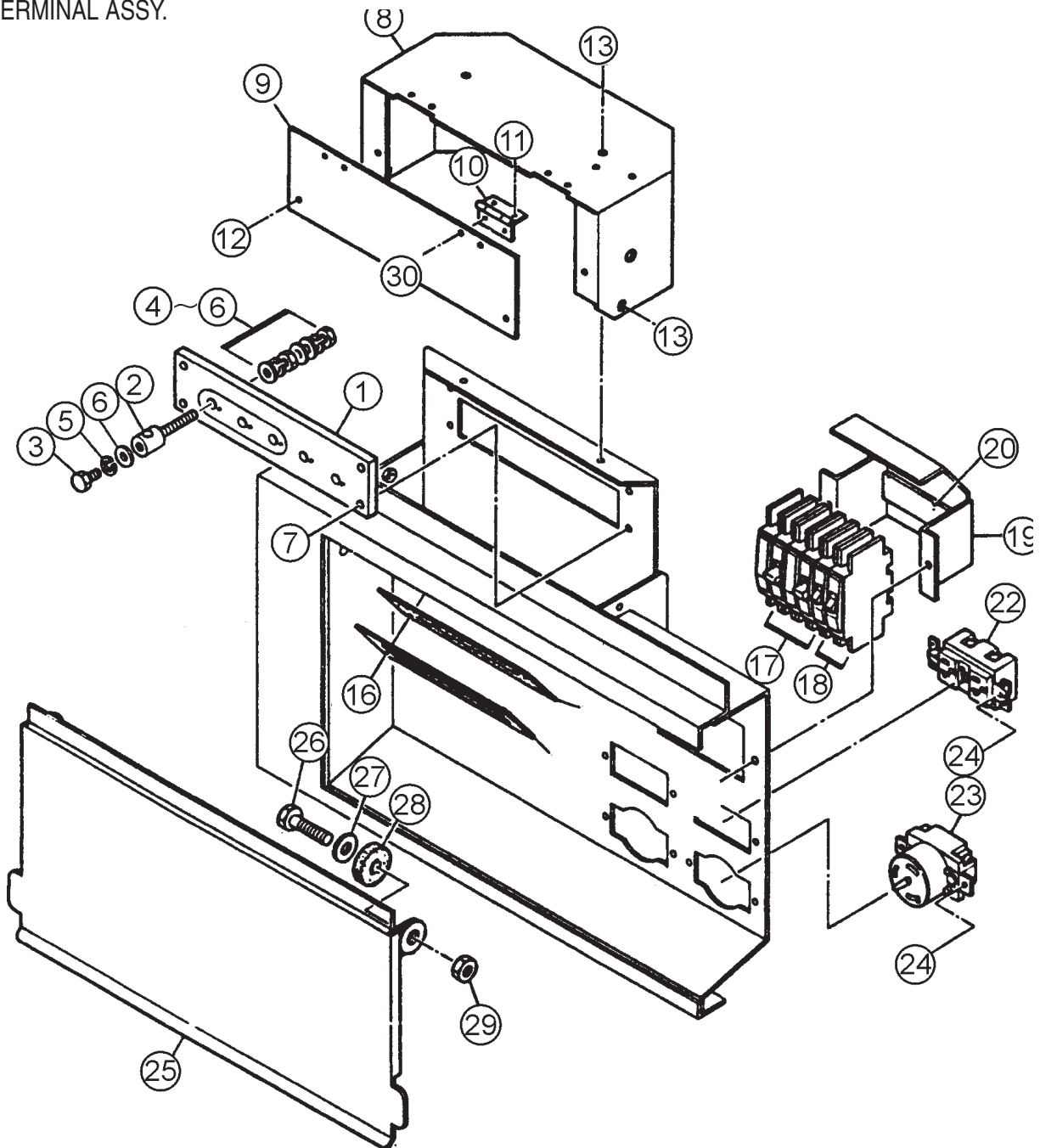

ADD THE FOLLOWING DIGITS AFTER THE PART NUMBER
WHEN ORDERING ANY PAINTED PANEL TO INDICATE
COLOR OF UNIT:

1-ORANGE	5-BLACK
2-WHITE	6-CATERPILLARYELLOW
3-SPECTRUM GRAY	7-CATO GOLD
4-SUNBELT GREEN	8-RED

THE SERIAL NUMBER MAY BE REQUIRED.

DCA-25SSIU --- OUTPUT TERMINAL ASSY.

OUTPUT TERMINAL ASSY.

<u>NO.</u>	<u>PART NO.</u>	<u>ITEM</u>	<u>QTY</u>	<u>REMARKS</u>
1	8091860103	TERMINAL PANEL	1	REPLACES M1230700003
2	0801830104A	OUTPUT TERMINAL BOLT	5	REPLACES M922000004
3	0801832204	TIE BOLT	5	REPLACES M9220000104
4	0039308000	HEX. NUT	10	
5	0040008000	LOCK WASHER	15	
6	0041408000	PLAIN WASHER	20	
7	011606025	HEX. HEAD BOLT	4	S/N7100001 TO S/N7102674; REPLACES 0016906025
	011206020	HEX. HEAD BOLT	4	S/N7102675~
8	M1236100303	TERMINAL COVER	1	S/N7100001 TO S/N7102784
	M1236100313	TERMINAL COVER	1	S/N7102785~
9	M1236100404	OUTPUT WINDOW	1	
10	0605010040	HINGE	2	
11	0027103010	MACHINE SCREW	4	
	0207003000	HEX.NUT	4	REPLACES 0030003000
	58413	PLAIN WASHER	4	REPLACES 0041203000
12	011206020	HEX. HEAD BOLT	2	REPLACES 0016906020
13	011106015	HEX. HEAD BOLT	4	REPLACES 0016906015
14	M1236400004	CABLE OUTLET COVER	1	
15	M1236300004	SUPPORTER, CABLE OUTLET COVER	1	
16	011206020	HEX. HEAD BOLT	6	REPLACES 0016906020
17	0601808804	CIRCUIT BREAKER	2	QOU250B 2P 50A
18	06018088030	CIRCUIT BREAKER	2	QOU120B 1P 50A
19	M1260700204	BREAKER FITTING COVER	1	
20	0222100115	CUSHION RUBBER	1	
21	011206020	HEX. HEAD BOLT	2	REPLACES 0016906020
22	0601812597	RECEPTACLE	2	GF530EM125V 20AX2 REPLACES 0601812549
23	0601811034	RECEPTACLE	2	CA6369 250V 50A ; REPLACES 0601812538
24	0021304015	MACHINE SCREW	8	REPLACES 0027104015
	0030004000	HEX. NUT	8	REPLACES 0207004000
25	M1236100503	TERMINAL COVER	1	
26	012212045	HEX.HEAD BOLT	2	REPLACES 0010112045
27	031112230	PLAIN WASHER	2	REPLACES 0041212000
28	M9310200004	STAY RUBBER	2	
29	0030012000	HEX. NUT	2	
30	0027103010	MACHINE SCREW	4	
	0207003000	HEX. NUT	4	REPLACES 0030003000

DCA-25SSIU --- BATTERY ASSY.

BATTERY ASSY.

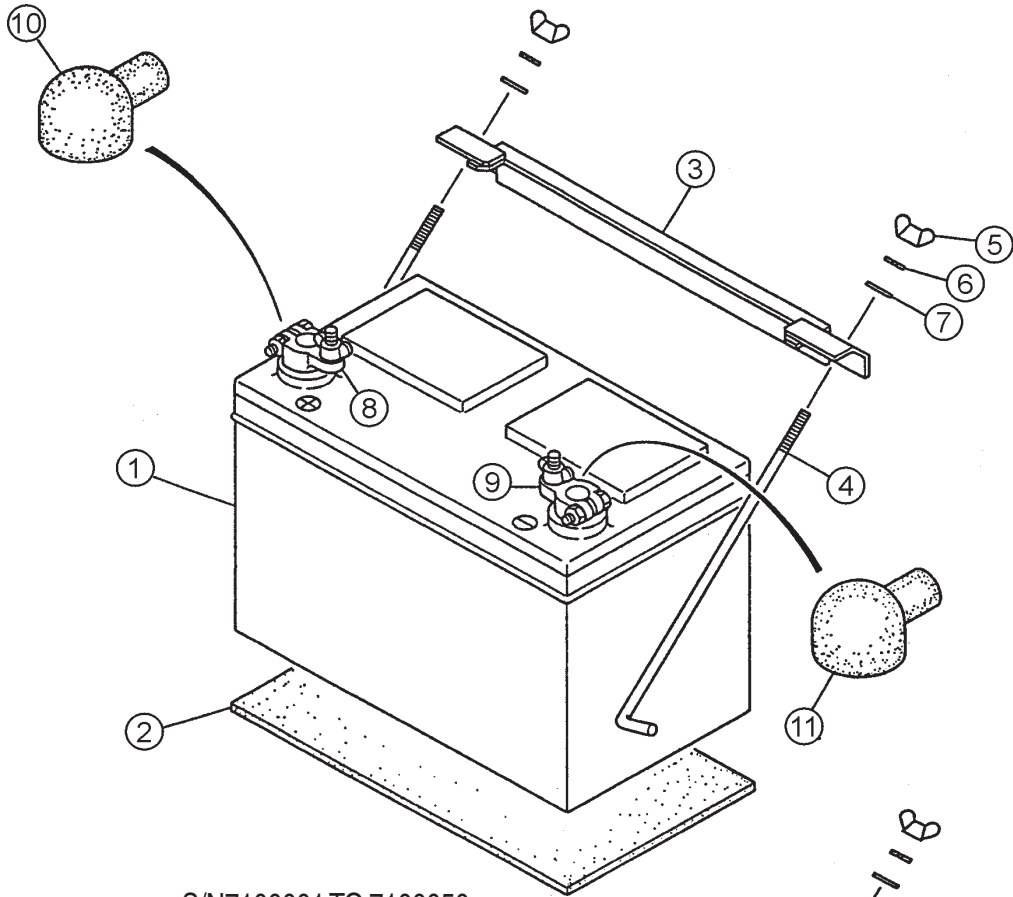

S/N710001 TO 710050

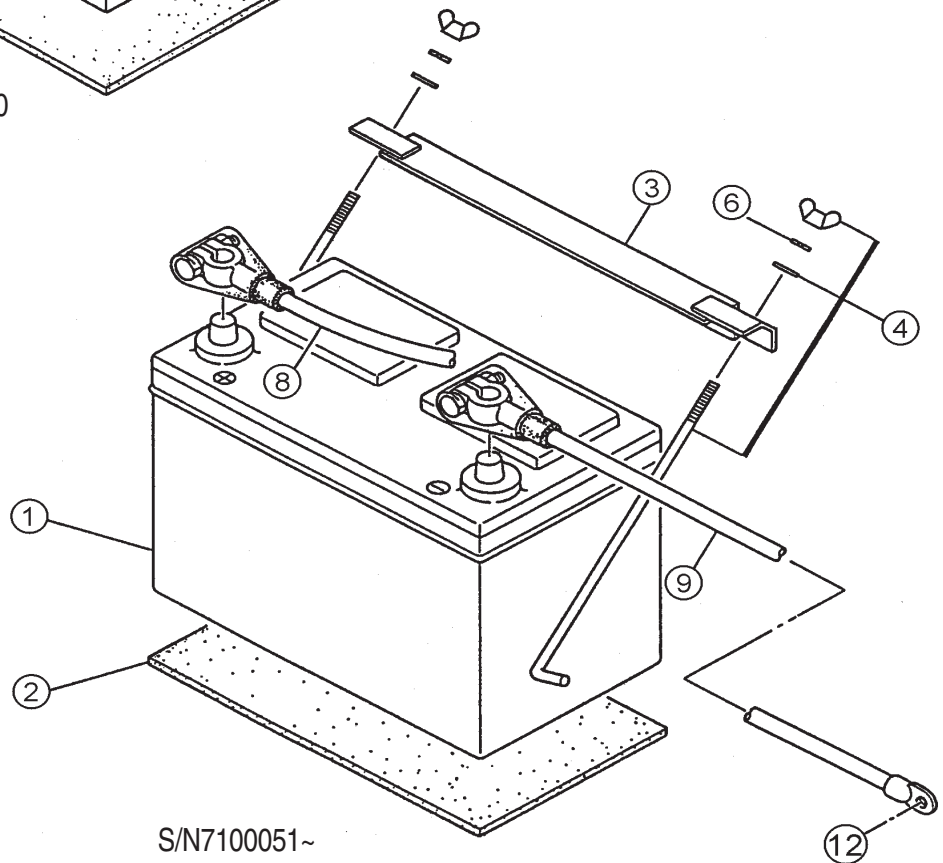

S/N710051~

BATTERY ASSY.

<u>NO.</u>	<u>PART NO.</u>	<u>ITEM</u>	<u>QTY.</u>	<u>REMARKS</u>
1	0602220185	BATTERY	1	427MF
2	M9310500014	BATTERY SHEET	1	
3	M9103000304	BATTERY BAND	1	
4	M0602220920	BATTERY BOLT SET	2	BHL10J;REPLACES M9103200004
5	0037808000	WING NUT	2	S/N7100001 TO S/N7100050
6	0040008000	LOCK WASHER	2	S/N7100001 TO S/N7100050
	0040006000	LOCK WASHER	2	S/N7100051~
7	031108160	PLAIN WASHER	2	S/N7100001 TO S/N7100050; REPLACES 0041208000
8	0602220310	TERMINAL ASSY.	1	NO.9P S/N7100001 TO S/N7100050
	M134640004	BATTERY CABLE	1	S/N7100051~
9	0602220311	TERMINAL ASSY.	1	NO.9P S/N7100001 TO S/N7100050
	M1346400104	BATTERY CABLE	1	S/N7100051 TO S/N7101005
	M2346400104	BATTERY CABLE	1	S/N7101006~
10	M1346400004	TERMINAL COVER	1	S/N7100001 TO S/N7100050; REPLACES M9310000304
11	M1346400104	TERMINAL COVER	1	S/N7100001 TO S/N7100050; REPLACES M9310000204
12	0016910020	HEX. HEAD BOLT	1	S/N7100051~
	0040510000	TOOTHED WASHER	1	S/N7100051~

ADD THE FOLLOWING DIGITS AFTER THE PART NUMBER
WHEN ORDERING ANY PAINTED PANEL TO INDICATE
COLOR OF UNIT:

1-ORANGE	5 -BLACK
2-WHITE	6 -CATERPILLAR YELLOW
3 -SPECTRUM GRAY	7 -CATO GOLD
4 -SUNBELT GREEN	8 -RED

THE SERIAL NUMBER MAY BE REQUIRED.

DCA-25SSIU --- MUFFLER ASSY.

MUFFLER ASSY.

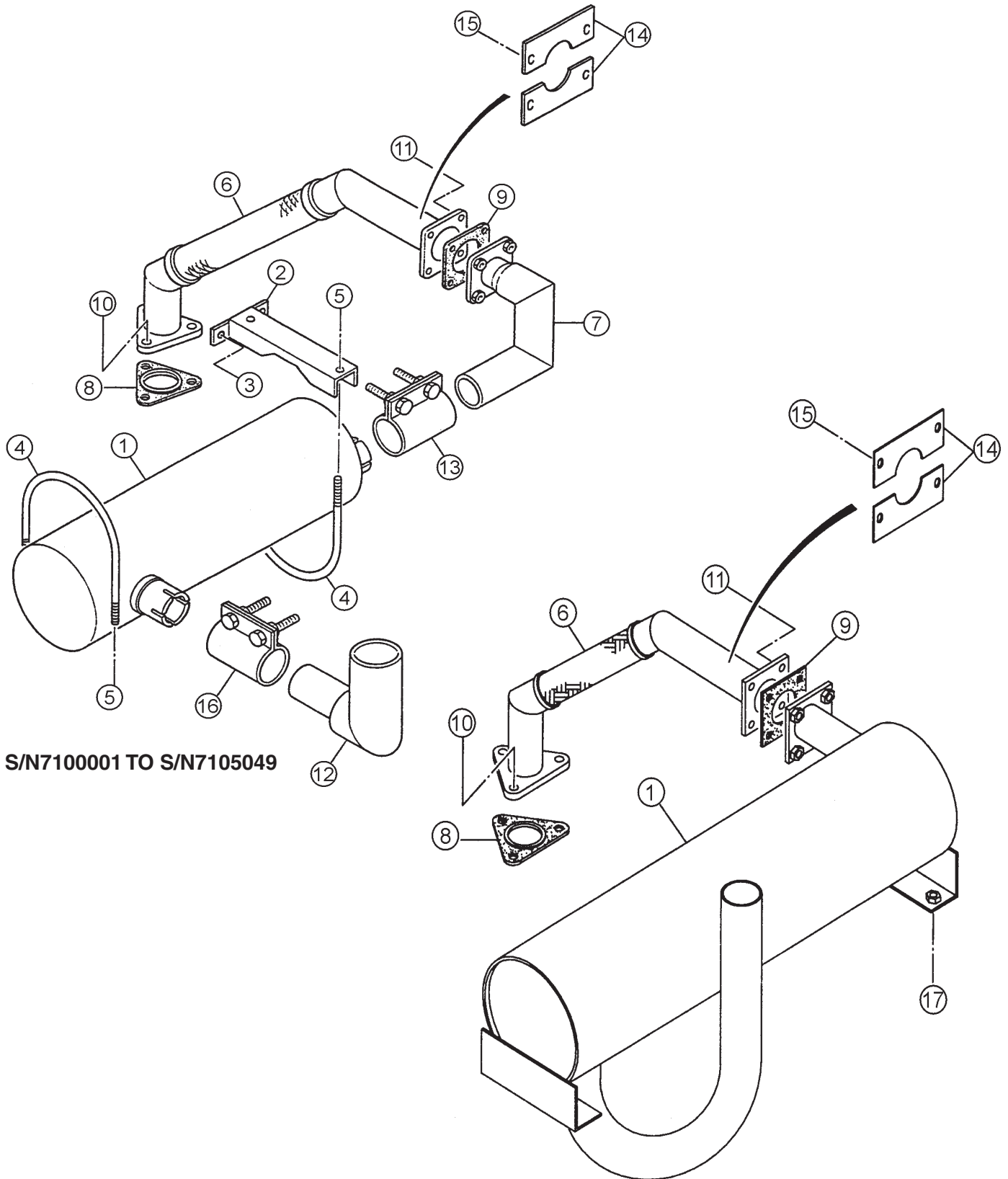

S/N7100001 TO S/N7105049

S/N7105050~

DCA-25SSIU --- MUFFLER ASSY.

MUFFLER ASSY.

<u>NO.</u>	<u>PART NO.</u>	<u>ITEM</u>	<u>QTY.</u>	<u>REMARKS</u>
1	0602300160	MUFFLER;MAM060249	1	S/N7100001 TO 7105049
1	0602300390	MUFFLER	1	S/N7105050~
2	M133040004	MUFFLER SUPPORTER	1	S/N7100001 TO 7105049
3	011008020	HEX. HEAD BOLT	2	REPLACES 0016908020; S/N7100001 TO 7105049
3	011008020	HEX. HEAD BOLT	4	REPLACES 0016908020; S/N7105050~
4	M1330400104	U BOLT	2	S/N7100001 TO 7105049
5	020108060	HEX. NUT	4	REPLACES 0037908000; S/N7100001 TO 7105049
	031108160	PLAIN WASHER	4	REPLACES 0041208000; S/N7100001 TO 7105049
6	M1333000703	EXHAUST PIPE	1	
7	M1333000803	EXHAUST PIPE	1	S/N7100001 TO 7105049
8	8943811610	GASKET	1	REPLACES 0602320102
9	M1333200004	GASKET	1	S/N 7100001 TO S/N7100865
	M1333200014	GASKET	1	S/N7100866~
10	9098400850	HEX. NUT	3	REPLACES 0602323001
	0040010000	LOCK WASHER	3	
11	0016908035	HEX. HEAD BOLT	4	
12	M1333000604	TAIL PIPE	1	S/N7100001 TO 7105049
13	0602325021	SEAL CLAMP	1	S/N7100001 TO 7105049
14	M1330400204	COVER	2	
15	011106015	HEX. HEAD BOLT	4	REPLACES 0016906015
16	0602325020	SEAL CLAMP	1	S/N7100001 TO 7105049
17	011008020	HEX. HEAD BOLT	4	REPLACES 0016908020;S/N7105050~

ADD THE FOLLOWING DIGITS AFTER THE PART NUMBER
WHEN ORDERING ANY PAINTED PANEL TO INDICATE

COLOR OF UNIT:

1-ORANGE	5-BLACK
2-WHITE	6-CATERPILLAR YELLOW
3-SPECTRUM GRAY	7-CATO GOLD
4-SUNBELT GREEN	8-RED

THE SERIAL NUMBER MAY BE REQUIRED.

DCA-25SSIU --- FUEL TANK ASSY.

FUEL TANK ASSY.

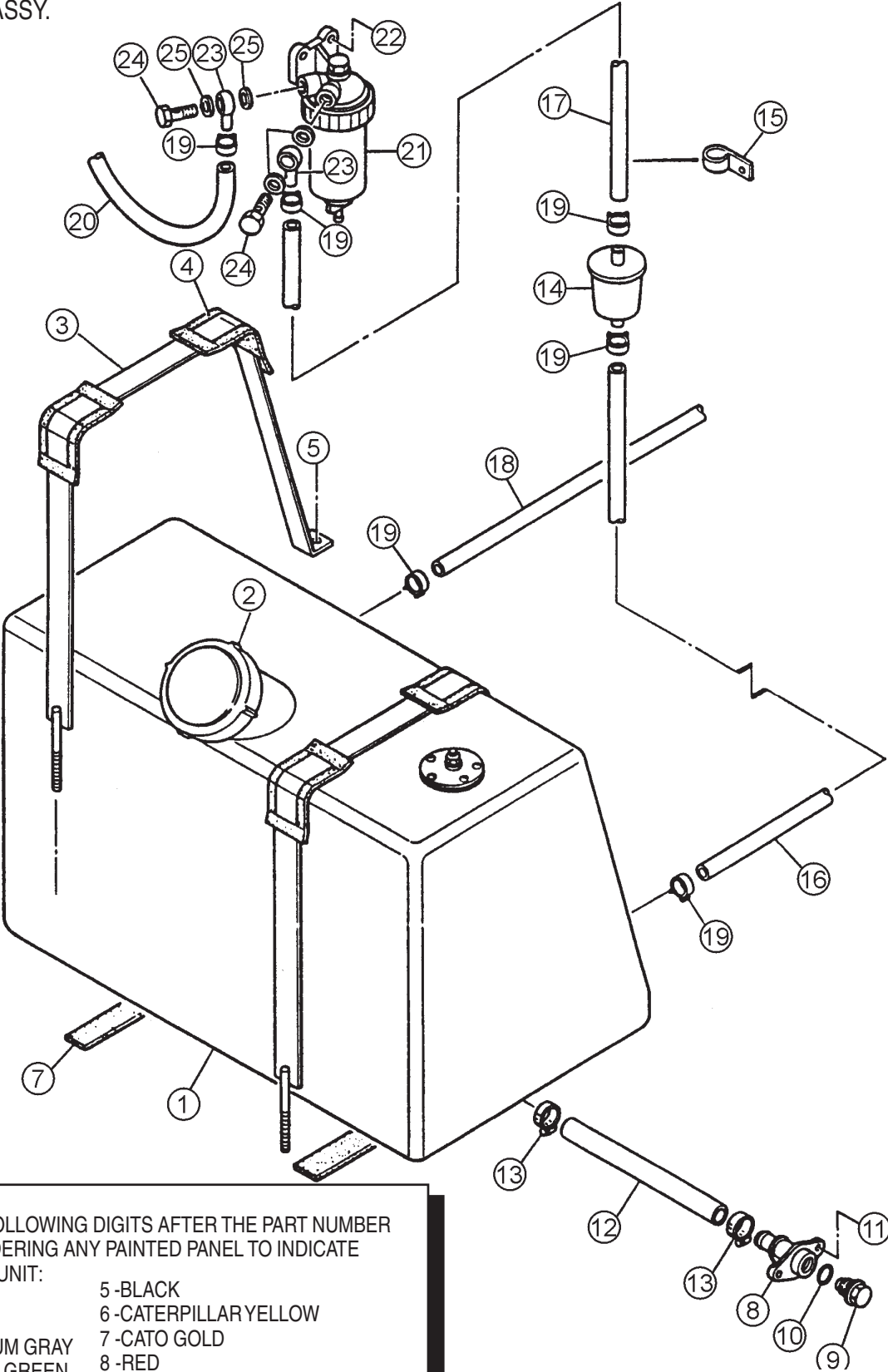

ADD THE FOLLOWING DIGITS AFTER THE PART NUMBER
WHEN ORDERING ANY PAINTED PANEL TO INDICATE
COLOR OF UNIT:

- | | |
|-----------------|---------------------|
| 1-ORANGE | 5-BLACK |
| 2-WHITE | 6-CATERPILLARYELLOW |
| 3-SPECTRUM GRAY | 7-CATO GOLD |
| 4-SUNBELT GREEN | 8-RED |

THE SERIAL NUMBER MAY BE REQUIRED.

DCA-25SSIU --- FUEL TANK ASSY.

FUEL TANK ASSY.

<u>NO.</u>	<u>PART NO.</u>	<u>ITEM</u>	<u>QTY.</u>	<u>REMARKS</u>
1	M1363000202	FUEL TANK	1	
2	0605505070	CAP, FUEL TANK	1	
3	M1363200004	TANK BAND	2	
4	M9310500104	SUPPORTER SHEET	4	
5	011008020	HEX. HEAD BOLT	2	REPLACES 0016908020
6	00379080000	HEX. NUT	2	S/N7100001 TO S/N7101449; REPLACES 0037908000
	0207308000	HEX. NUT	2	S/N7101450~
	031108160	PLAIN WASHER	2	S/N7100001 TO S/N7101449; REPLACES 0041208000
7	0222100080	RUBBER SHEET	4	
8	1502025103C	DRAIN JOINT	1	REPLACES M9200000003
9	M9200200004	DRAIN BOLT	1	
10	0150000018	O RING	1	
11	011206020	HEX. HEAD BOLT	2	REPLACES 0016906020
12	M1363400104	DRAIN HOSE	1	
13	06015515198	HOSE BAND	2	REPLACES 0605515064
14	0602042420	FUEL FILTER	1	PTG15P
15	0602220911	CLAMP	1	
16	0191300730	SUCTION HOSE	1	
17	0191300380	SUCTION HOSE	1	S/N7100001 TO S/N7102685
	0191300920	SUCTION HOSE	1	S/N7102686~
18	0191301060	RETURN HOSE	1	
19	0605515109	HOSE BAND	6	S/N7100001 TO S/N7102685
	0605515109	HOSE BAND	8	S/N7102686~
20	0191300520	SUCTION HOSE	1	S/N7102686~
21	1132008410	WATER SEDIMENTER	1	S/N7102686~; REPLACES 0602042512
22	0016908025	HEX. HEAD BOLT	2	S/N7102686~
23	5154115680	PIPE	2	S/N7102686~; REPLACES 0602042660 AND 5154112231
24	1096751460	JOINT BOLT	2	S/N7102686~; REPLACES 0602042620 AND 9099063251
25	9095720140	PACKING	4	S/N7102686~; REPLACES 0602042640

DCA-25SSIU --- ENCLOSURE ASSY.

ENCLOSURE ASSY.

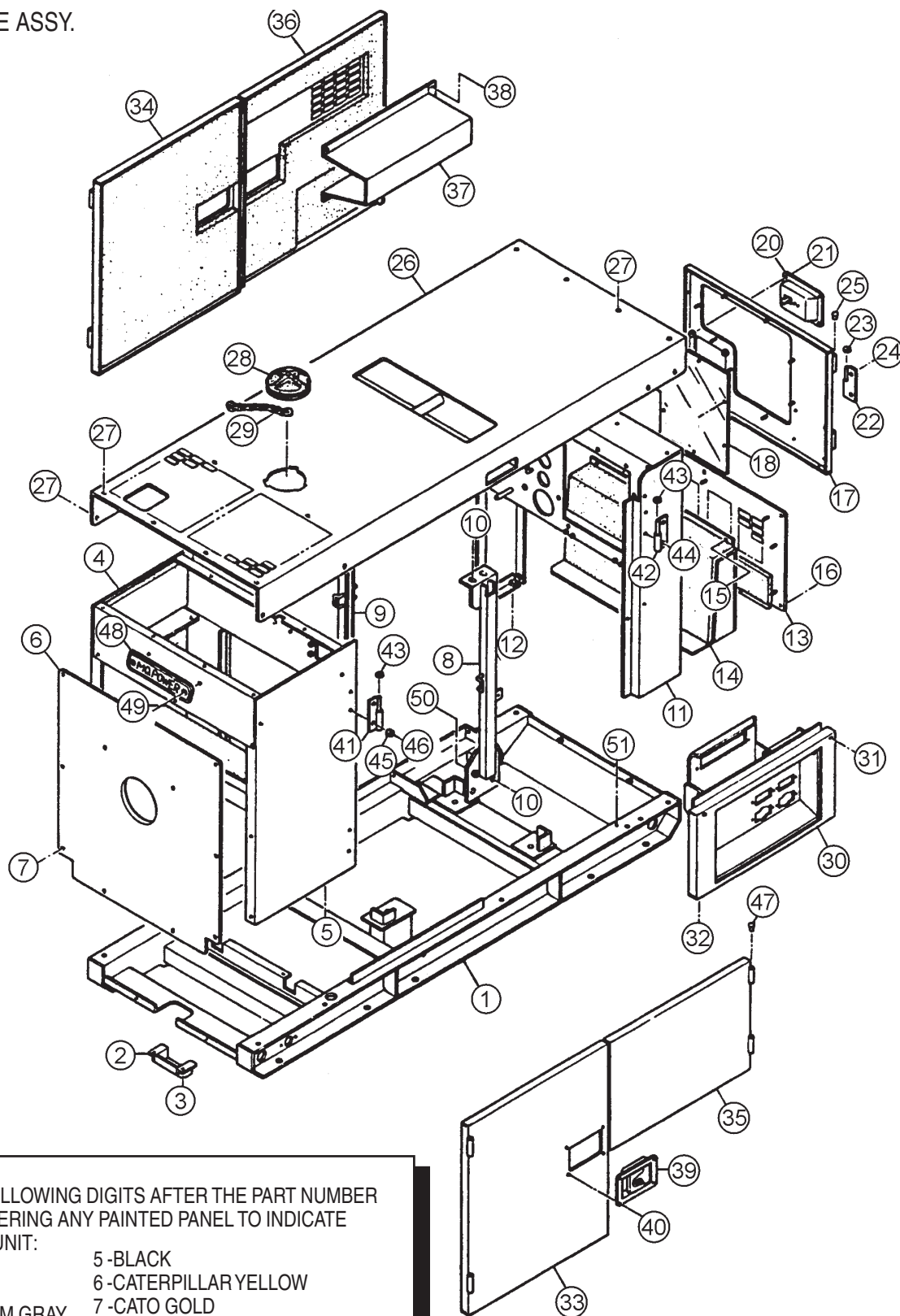

ADD THE FOLLOWING DIGITS AFTER THE PART NUMBER
WHEN ORDERING ANY PAINTED PANEL TO INDICATE
COLOR OF UNIT:

- | | |
|-----------------|----------------------|
| 1-ORANGE | 5-BLACK |
| 2-WHITE | 6-CATERPILLAR YELLOW |
| 3-SPECTRUM GRAY | 7-CATO GOLD |
| 4-SUNBELT GREEN | 8-RED |

THE SERIAL NUMBER MAY BE REQUIRED.

DCA-25SSIU --- ENCLOSURE ASSY.

ENCLOSURE ASSY.

<u>NO.</u>	<u>PART NO.</u>	<u>ITEM</u>	<u>QTY.</u>	<u>REMARKS</u>
1	M1413000212	BASE	1	S/N7100291 TO S/N7104749 REPLACES M1413000202
	M1413000222	BASE	1	S/N7104750~
2	M1413400004	UNDER COVER	1	
3	011008020	HEX. HEAD BOLT	2	REPLACES 0016908020
4	M1423000302	FRONT FRAME	1	S/N7100001 TO 7105049
	M1493100503	ACOUSTIC SHEET	1	S/N7100001 TO 7105049
	M1423000312	FRONT FRAME	1	S/N7105050~
	M1493100513	ACOUSTIC SHEET	1	S/N7105050~
5	011008020	HEX.HEAD BOLT	4	REPLACES 0016908020
6	M1423200304	COVER, FRONT FRAME	1	
	M1493100604	ACOUSTIC SHEET	1	
7	011008020	HEX HEAD BOLT	11	REPLACES 0016908020
8	M1433000203	CENTER FRAME	1	
9	M1433000303	CENTER FRAME	1	
10	0010114030	HEX. HEAD BOLT	8	
	030214350	LOCK WASHER	8	REPLACES 0040014000
	031114260	PLAIN WASHER.....	8	REPLACES 0041214000
11	M1443000502	REAR FRAME	1	
12	011008020	HEX. HEAD BOLT	4	REPLACES 0016908020
	0040508000	TOOTHED WASHER	1	
13	M1443300513	REAR COVER	1	REPLACES M1443300503
	M1493300304	ACOUSTIC SHEET	1	
14	M1443300403	DUCT, REAR COVER	1	
	M1493300404	ACOUSTIC SHEET	1	
15	0207006000	HEX. NUT	7	
16	011008020	HEX. HEAD BOLT	6	S/N7100001 TO S/N7100290; REPLACES 0016908020
	011008020	HEX. HEAD BOLT	7	S/N7100291~; REPLACES 0016908020
17	M1443200613	REAR DOOR	1	REPLACES M1443200603
18	M1443600004	WINDOW PLATE	1	S/N7100001 TO S/N7100725
	M1443600104	WINDOW PLATE	1	S/N7100726 TO S/N7101589
	M1443600114	WINDOW PLATE	1	S/N7101590~
19	020106050	HEX. NUT	6	S/N7100001 TO S/N7101449; REPLACES 0037906000
	0027306000	HEX. NUT	6	S/N7101450 TO S/N7101589
	0207306000	HEX. NUT	8	S/N7101590~
	952404470	PLAIN WASHER.....	12	S/N7100001 TO S/N7101449; REPLACES 0041206000
	952404470	PLAIN WASHER.....	6	S/N7101450 TO S/N7101589; REPLACES 0041206000
	952404470	PLAIN WASHER.....	8	S/N7101590~; REPLACES 0041206000
20	M911300002	DOOR HANDLE ASSY.	1	
21	0021706015	MACHINE SCREW	4	
	020106050	HEX. NUT	4	REPLACES 0030006000

DCA-25SSIU --- ENCLOSURE ASSY.

ENCLOSURE ASSY.

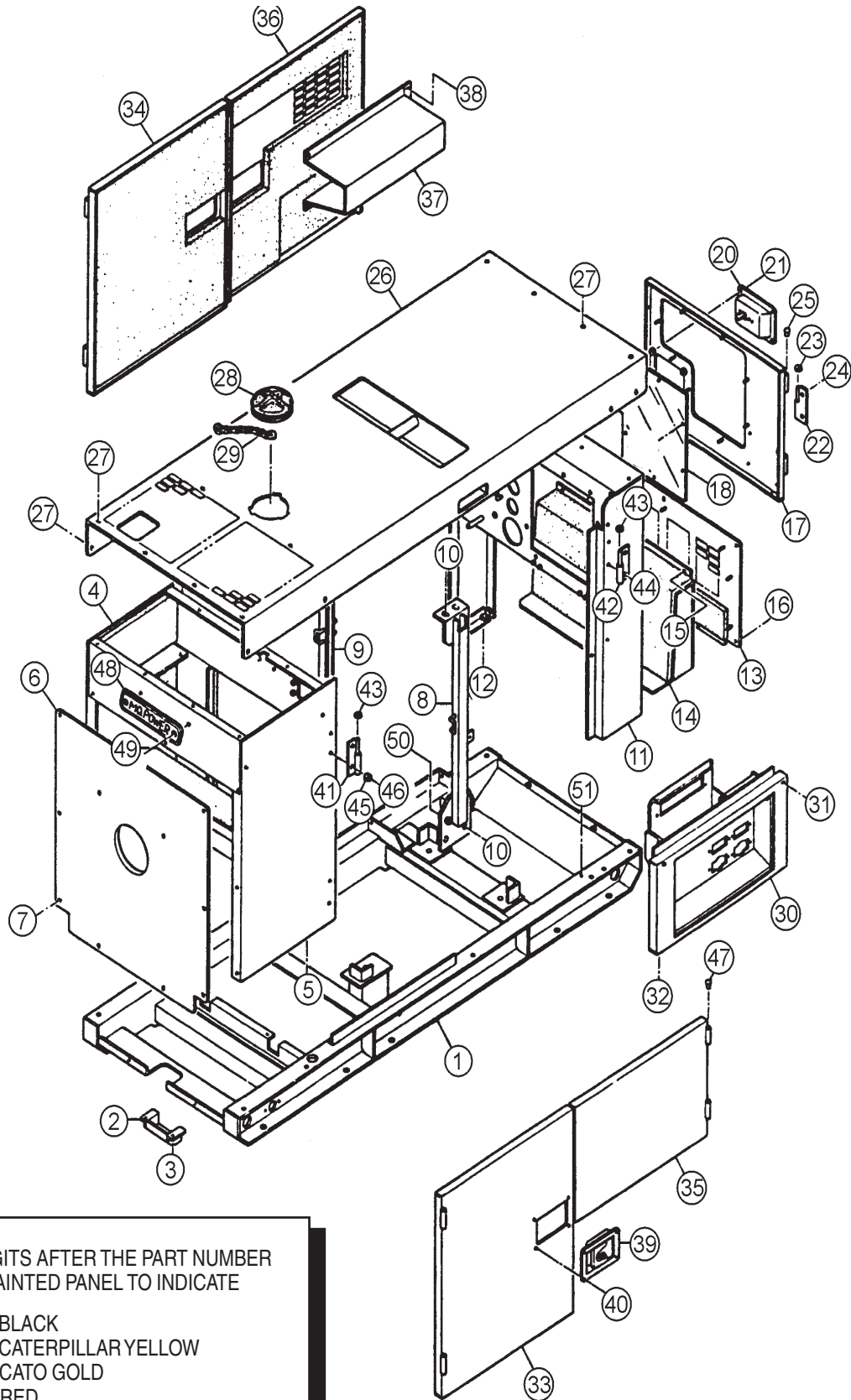

ADD THE FOLLOWING DIGITS AFTER THE PART NUMBER
WHEN ORDERING ANY PAINTED PANEL TO INDICATE
COLOR OF UNIT:

- | | |
|-----------------|----------------------|
| 1-ORANGE | 5-BLACK |
| 2-WHITE | 6-CATERPILLAR YELLOW |
| 3-SPECTRUM GRAY | 7-CATO GOLD |
| 4-SUNBELT GREEN | 8-RED |

THE SERIAL NUMBER MAY BE REQUIRED.

DCA-25SSIU --- ENCLOSURE ASSY.

ENCLOSURE ASSY.

<u>NO.</u>	<u>PART NO.</u>	<u>ITEM</u>	<u>QTY.</u>	<u>REMARKS</u>
22	M9110100204	HINGE	2	
23	M9116100004	WASHER	2	
24	0021808020	MACHINE SCREW	3	
25	0845031504	BLIND PLUG	2	REPLACES M9310000004
26	M1463000202	ROOF PANEL	1	S/N7100000 TO S/N7104749
26	M1463000212	ROOF PANEL	1	S/N7104750 TO S/N7105049
	M1463000222	ROOF PANEL	1	S/N7105050~
	M1493500203	ACOUSTIC SHEET	1	S/N7100000 TO S/N7104749
	M1493500203	ACOUSTIC SHEET	1	S/N7104750~
27	011008020	HEX. HEAD BOLT	18	REPLACES 0016908020
28	1625165103	BONNET CAP	1	REPLACES M9310000103
29	1625165204	CHAIN ASSY.....	1	REPLACES M1483600204
30	M1443100202	SPLASHER PANEL	1	S/N7100001 TO S/N7102784
	M1443100212	SPLASHER PANEL	1	S/N7102785
31	0016908050	HEX. HEAD BOLT	2	
32	011008020	HEX. HEAD BOLT	2	REPLACES 0016908020
33	M1453000703	SIDE DOOR	1	
	M1493400904	ACOUSTIC SHEET	1	
34	M1453000903	SIDE DOOR	1	
	M1493401004	ACOUSTIC SHEET	1	
35	M1453001003	SIDE DOOR	1	
	M1493401104	ACOUSTIC SHEET	1	
36	M1453000803	SIDE DOOR	1	
	M1493400804	ACOUSTIC SHEET	1	
37	M1453300503	DUCT	1	
38	0207006000	HEX. NUT	4	
39	B9114000002	DOOR HANDLE ASSY.....	3	REPLACES M9113000002
40	0027106016	MACHINE SCREW	12	REPLACES 0021806015
	020106050	HEX. NUT	12	REPLACES 0030006000
41	M9110100204	HINGE	4	
42	M9110100304	HINGE	4	
43	M9116100004	WASHER	8	
44	0021808020	MACHINE SCREW	9	
45	0601850097	DOOR STOPPER	8	
46	0027208025	MACHINE SCREW	8	
47	0845031504	BLIND PLUG	8	REPLACES M9310000004
48	0600500090	EMBLEM	1	
49	0021106015	MACHINE SCREW	2	
50	012210025	HEX. HEAD BOLT	1	REPLACES 0016910025
	0040510000	TOOTHED WASHER	1	
51	011008020	HEX. HEAD BOLT	1	REPLACES 0016908020
	0040508000	TOOTHED WASHER	1	

DCA-25SSIU --- RUBBER SEAL ASSY.

RUBBER SEAL ASSY.

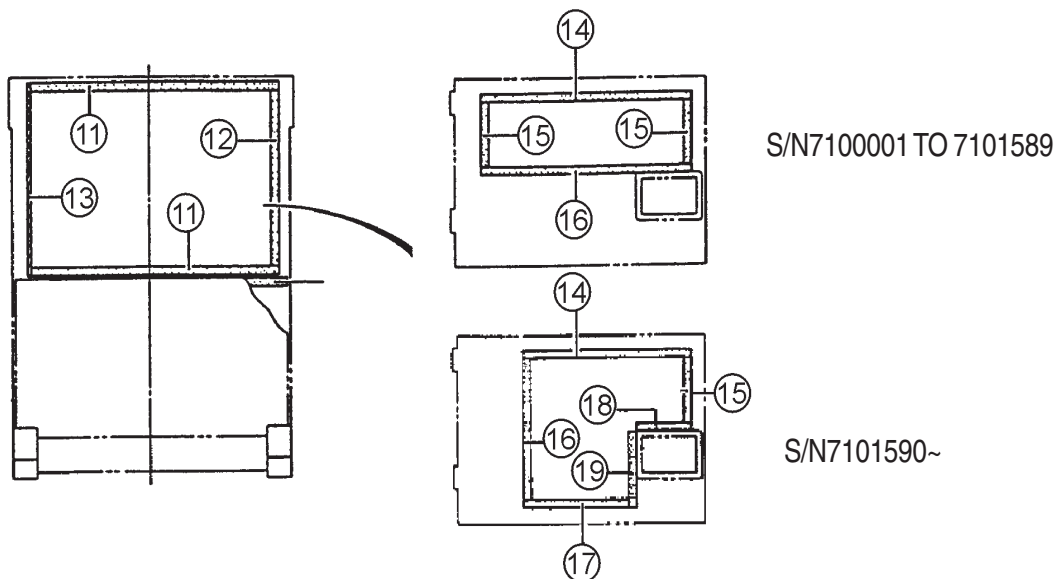
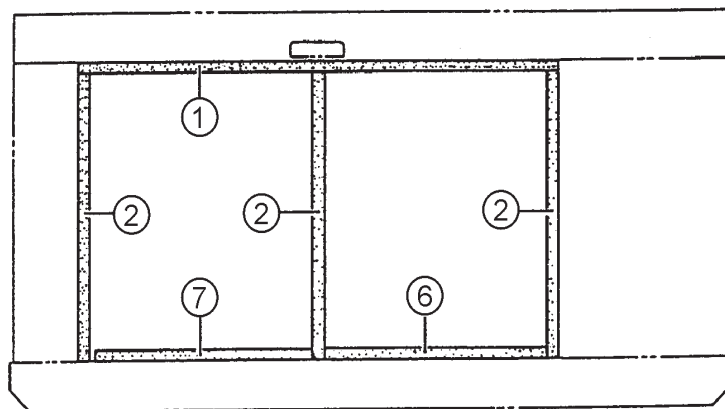
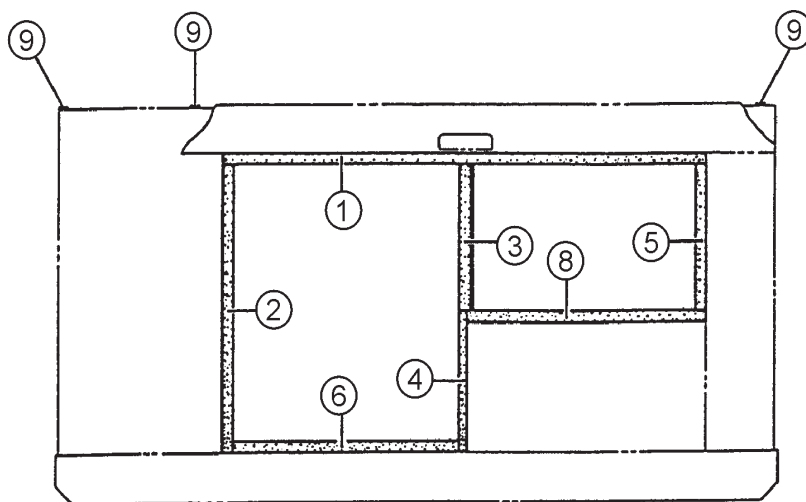

DCA-25SSIU --- RUBBER SEAL ASSY.

RUBBER SEAL ASSY.

<u>NO.</u>	<u>PART NO.</u>	<u>ITEM</u>	<u>QTY.</u>	<u>REMARKS</u>
1	0228910300	RUBBER SEAL	2	
2	0228900725	RUBBER SEAL	4	
3	M1490300004	RUBBER SEAL	1	
4	0228800360	RUBBER SEAL	1	
5	0228900370	RUBBER SEAL	1	
6	0228800605	RUBBER SEAL	2	
7	0229200595	RUBBER SEAL	1	
8	0228900645	RUBBER SEAL	1	
9	0229200750	RUBBER SEAL	3.....	S/N7100001 TO S/N7101589
	0229200750	RUBBER SEAL	2.....	S/N7101590~
10	0229200740	RUBBER SEAL	1	
11	0228800670	RUBBER SEAL	2	
12	0228800445	RUBBER SEAL	1	
13	0228800485	RUBBER SEAL	1	
14	0228100568	RUBBER SEAL	2.....	S/N7100001 TO S/N7101589
	0228100458	RUBBER SEAL	1.....	S/N7101590~
15	0228100170	RUBBER SEAL	2.....	S/N7100001 TO S/N7101589
	0228100171	RUBBER SEAL	1.....	S/N7101590~
16	0228100351	RUBBER SEAL	1.....	S/N7101590~
17	0228100285	RUBBER SEAL	1.....	S/N7101590~
18	0228100153	RUBBER SEAL	1.....	S/N7101590~
19	0228100180	RUBBER SEAL	1.....	S/N7101590~

DECAL ASSY.

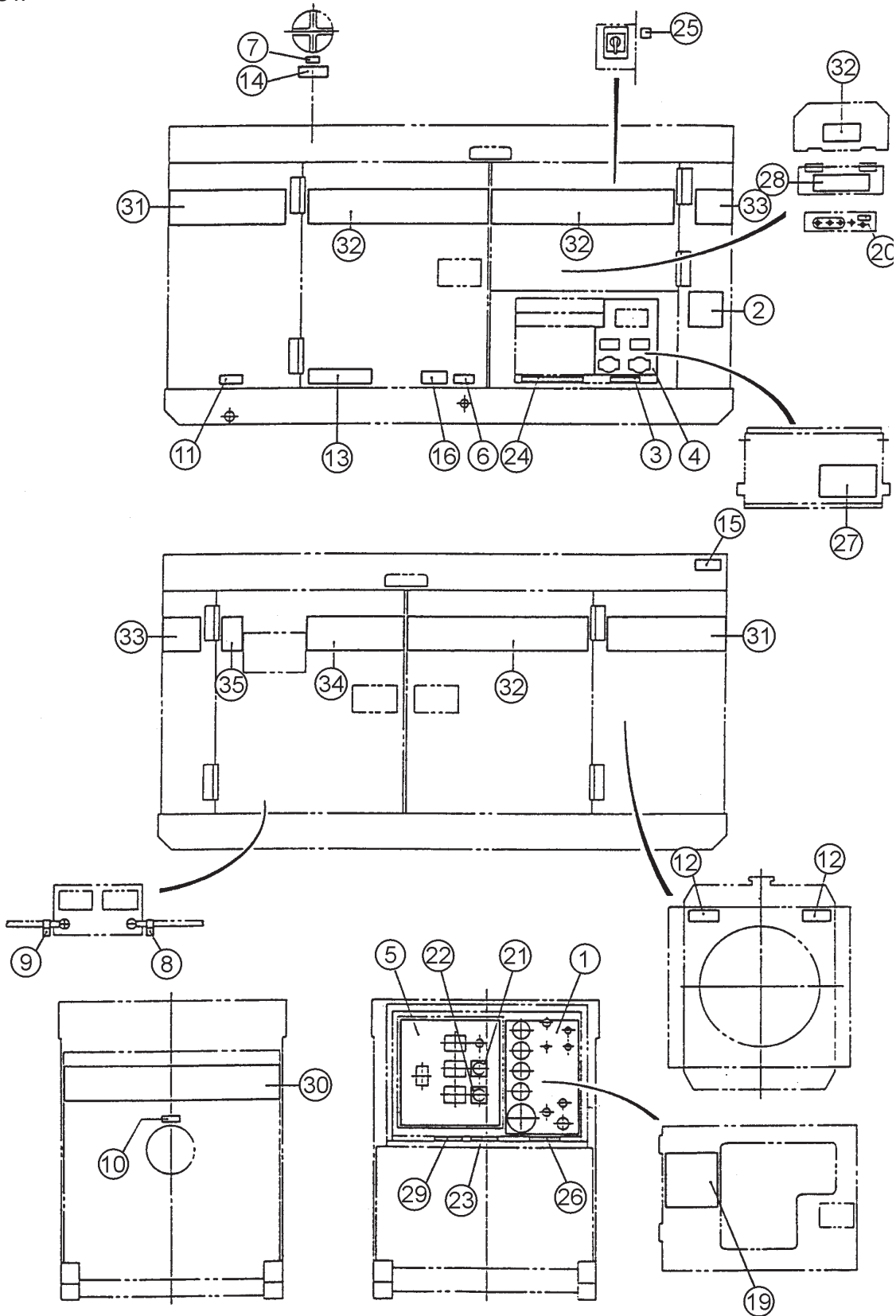

DECAL ASSY.

<u>NO.</u>	<u>PART NO.</u>	<u>ITEM</u>	<u>QTY.</u>	<u>REMARKS</u>
1	M1550000003	DECAL; ENGINE OPERATING	1	M15000000
2	M1550000104	DECAL; NOTE	1	M15000010
3	M1550000204	DECAL; NOTE	1	M15000020
4	M1550000303	DECAL; AUXILLARY OUTPUT	1	M15000030
5	M1550000403	DECAL; GENERATOR CONTROL	1	M15000040
6	M9500000004	DECAL; OIL DRAIN PLUG	1	M90000000
7	M9500100004	DECAL; WATER	1	M90010000
8	M9500300004	DECAL; -	1	M90030000
9	M9500300104	DECAL; +	1	M90030010
10	M9500500004	DECAL; DIESEL FUEL	1	M90050000
11	M9500500104	DECAL; FUEL DRAIN PLUG	1	M90050010
12	M9503000004	DECAL; WARNING	2	M90300000
13	M9503000103	DECAL; WATER, OIL CHECK	1	M90300000
14	M9503100004	DECAL; WARNING	1	M90310000
15	M9503200004	DECAL; WARNING	1	M90320000
16	M9510100004	DECAL; CAUTION	1	M91010000
17	M9520100503	DECAL; WARNING	1	S/N7100001 TO 7100600; REPLACES M9510100104
18	M9520100503	DECAL; WARNING	1	S/N7100001 TO 7100600; REPLACES M9510100204
19	M9510200002	DECAL; MQ	1	M91020000
20	M9520000004	DECAL; GROUND	1	M92000000
21	M9520000104	DECAL; AMMETER CHANGE OVER SWITCH	1	M92000010
22	M9520000204	DECAL; VOLTMETER CHANGE OVER SWITCH	1	M92000020
23	M9520100004	DECAL; WARNING	2	M92010000
24	M9520100503	DECAL; WARNING	1	S/N7100001 TO 7100600; REPLACES M9520100104
	M9520100503	DECAL; WARNING	1	M92010050 M9100601~
25	M9520100204	DECAL; CAUTION	1	M92010020A
26	M9520100304	DECAL; SAFETY INSTRUCTIONS	1	M92010030
27	M9520100404	DECAL; DANGER	1	M92010040
28	M9520200003	DECAL; CONNECTION OF OUTPUT CABLE	1	M92020000
29	M9520200104	DECAL; OVER CURRENT RELAY	1	M92020010
30	M1560100403	STRIPE; WHISPERWATT	1	
31	M1560100303	STRIPE; MQ POWER	2	
32	M1560100004	STRIPE;	3	
33	M1560100504	STRIPE; 25	2	
34	M1560100104	STRIPE	1	
35	M1560100204	STRIPE	1	

ISUZU C240 --- CYLINDER HEAD AND COVER ASSY.

CYLINDER HEAD AND COVER ASSY.

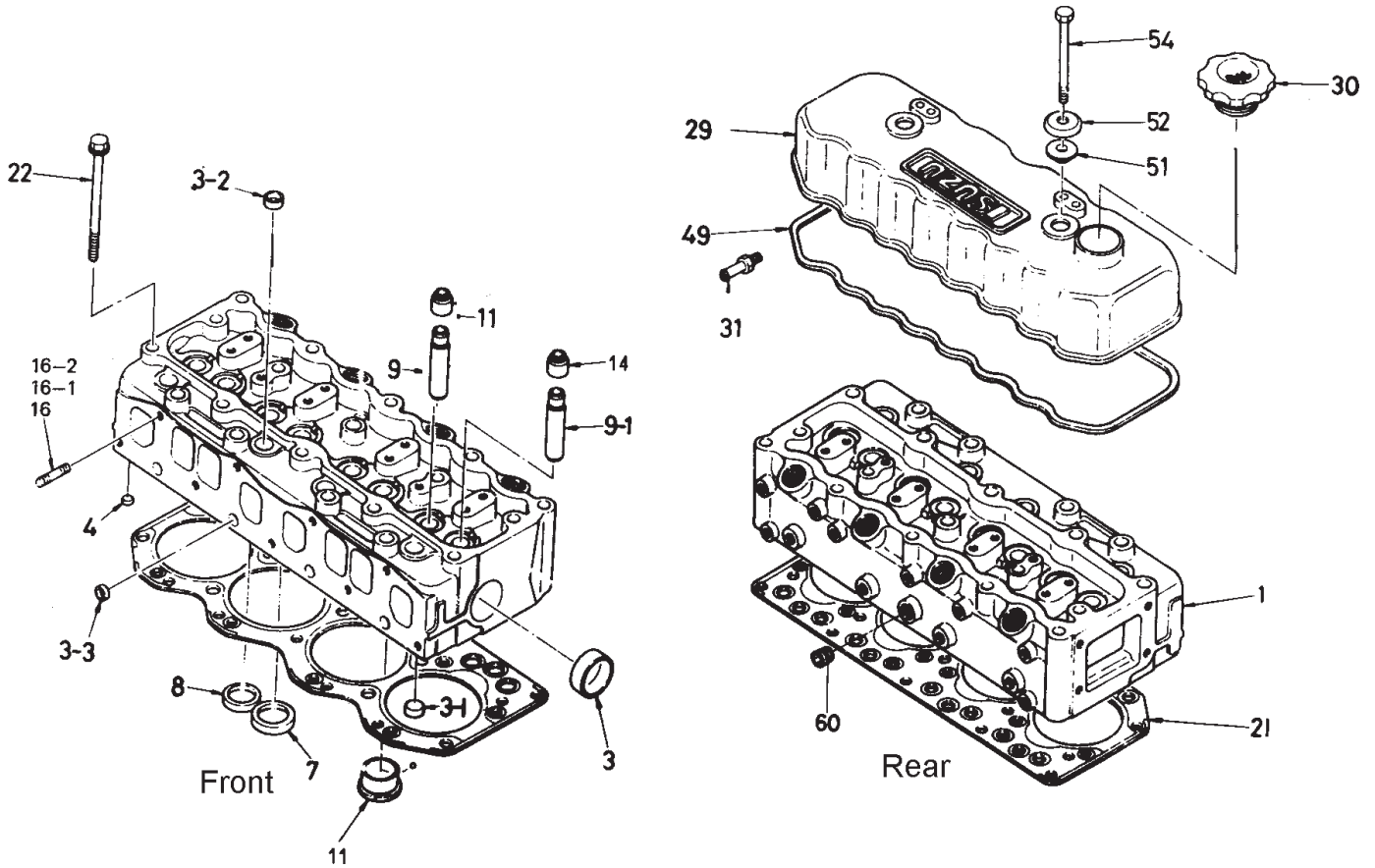

ISUZU C240 --- CYLINDER HEAD AND COVER ASSY.

CYLINDER HEAD AND COVER ASSY.

<u>NO.</u>	<u>PART NO.</u>	<u>ITEM</u>	<u>QTY.</u>	<u>REMARKS</u>
1	5111102070	CYLINDER HEAD ASSY.	1	
3	1096000051	SEALING CUP, RR FACE D=44	1	
3-1	5111290060	SEALING CUP, LOWER D=16	4	
3-2	5112190080	SEALING CUP, UPPER D=18	5	
3-3	5096000130	SEALING CUP, DRILLED D=12	4	
4	9098605220	PLUG; LOWER CYLINDER HEAD PLATE	4	
7	5117150230	VALVE SEAT INLET INSERT	4	
8	5117110260	VALVE SEAT EXHAUST INSERT	4	
9	5117210160	VALVE INLET HEAD GUIDE	4	
9-1	5117210160	VALVE EXHAUST HEAD GUIDE	4	
11	5111501080	HOT PLUG ASSY.	4	
14	5125690060	INLET AND EXHAUST VALVE SEAL	8	
16	9041108350	MANIFOLD STUD	3	
16-1	9041108400	MANIFOLD STUD	3	
16-2	9041108450	MANIFOLD STUD	1	
21	5111410690	CYLINDER HEAD GASKET	1	
22	5090090530	BOLT	19	
29	5111702400	CYLINDER HEAD COVER ASSY.	1	
30	9117510381	OIL FILLER CAP	1	
31	5111790520	BREATHER NIPPLE	1	
49	5111730170	HEAD COVER PACKING	1	
51	9111798080	HEAD COVER FIX. PACKING	2	
52	9111791320	WAHER	2	
54	5090000960	BOLT	2	
60	5096050050	CYLINDER HEAD OIL COOLER PLUG	1	

ISUZU C240 --- CYLINDER BLOCK ASSY.

CYLINDER BLOCK ASSY.

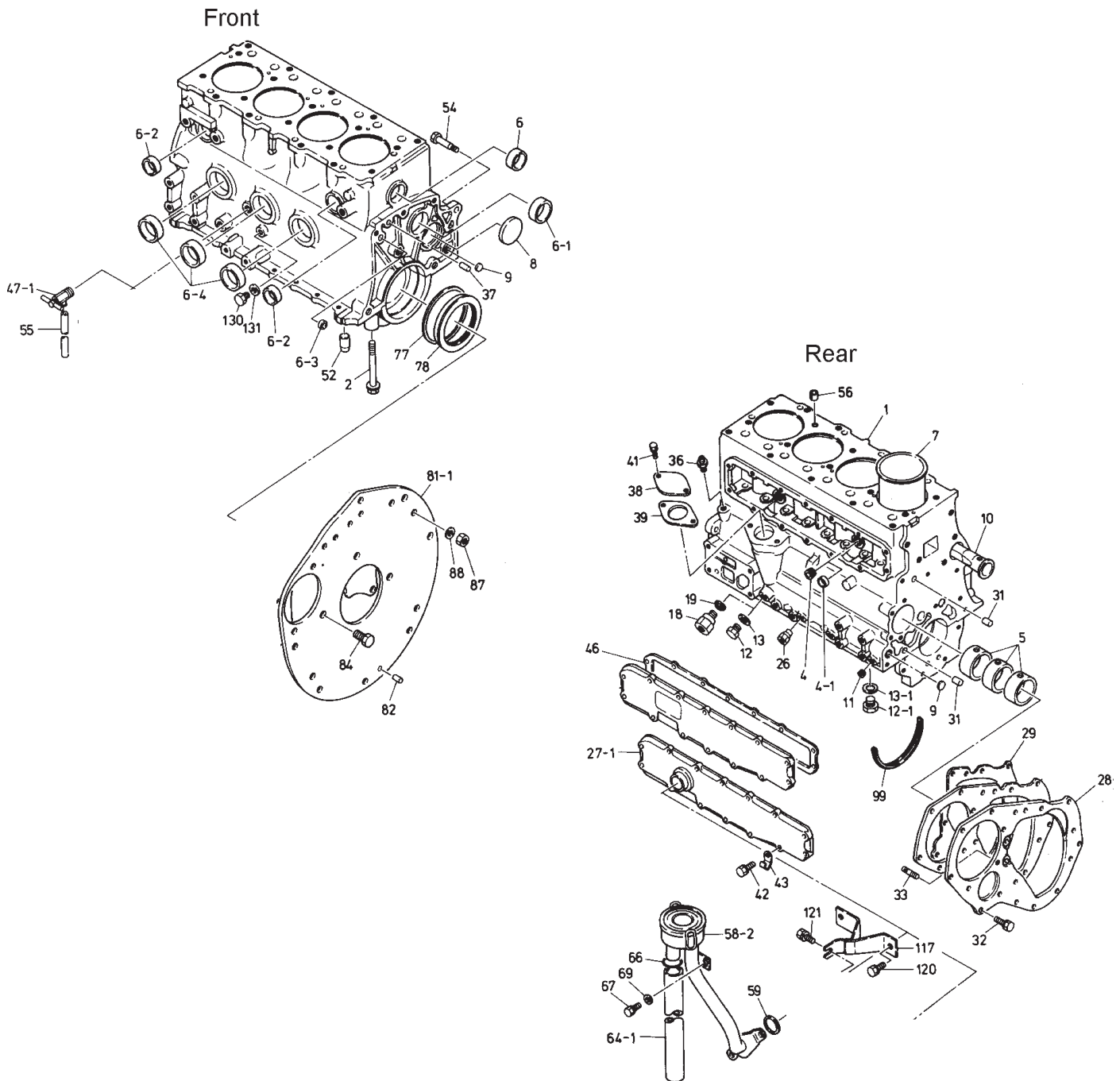

ISUZU C240 --- CYLINDER BLOCK ASSY.

CYLINDER BLOCK ASSY.

<u>NO.</u>	<u>PART NO.</u>	<u>ITEM</u>	<u>QTY.</u>	<u>REMARKS</u>
1	5112101771	CYLINDER BLOCK ASSY.	1	
2	9098025910	BOLT	10	
4	9096640340	PLUG; 1/2 TAPPET CHAMBER	2	
4-1	5112190080	SEALING CUP CHAMBER D=18	2	
5	5116100010	BEARING KIT; CAM. STANDARD	1	
6	5112190180	SEALING CUP RR FACE D=36	1	
6-1	5112190170	SEALING CUP RR FACE D=38	1	
6-2	5112190150	SEALING CUP LH SIDE D=32	2	
6-3	5096000130	SEALING CUP RR FACE D=12	1	
6-4	1096000051	SEALING CUP LH SIDE D=45	3	
7	9112612300	CYLINDER LINER	4	
8	8942505140	PLUG; CAMSHAFT BRIDGE PLATE	1	
9	5111290060	PLUG; OIL GALLERY PLATE	2	
10	5112210020	DUCT; CYL. BLOCK WATER	1	
11-1	5096050161	PLUG; OIL GALLERY 1/8	1	
12-1	9992023160	PLUG; OIL GALLERY SCREW	1	
13-1	9095714160	PLUG PACKING	1	
26	5096500210	INJ. PUMP OIL FEED NIPPLE	1	
27-1	9112976500	TAPPET CHAMBER COVER ASSY.	1	
28	9113111530	FRONT CYL. BLOCK PLATE	1	
29	5113120110	FRONT PLATE PACKING	1	
31	9081510240	FRONT PLATE STRAIGHT PIN	2	
32	9019008220	BOLT	3	
36	9099022990	ROCKER OIL FEED NIPPLE	1	
37	9081610320	REAR PLATE STRAIGHT PIN	1	
42-1	9019008180	BOLT	12	
42-2	9019008220	BOLT	2	
43	9099168160	TAPPET CHAMBER COVER CLIP	2	
46	5112920110	CHAMBER COVER PACKING.....	1	REPLACES 5112920150
47-1	9097040380	WATER DRAIN COCK	1	
52	9098785970	CRANK CASE PIN	2	
54-2	8942008311	BOLT	1	
55	9099138340	PIPE; VINYL WATER DRAIN	1	
56	9112290490	CYLINDER BLOCK DOWEL	2	
58-2	5117400211	BREATHER AIR ASSY.	1	
59	9099210990	BREATHER PACKING	1	
64-1	9097130870	PIPE; VINYL BREATHER	1	
66	9099152380	CLIP	1	
67	9019008180	BOLT	1	
69	9091645080	WASHER	1	
77	9123631120	SPACER; OIL SEAL	1	
78	5096250360	CRANK SHAFT REAR SEAL	1	
81	9113411940	REAR CYLINDER BLOCK PLATE	1	
84	5090002270	BOLT	3	
99	9112581080	OIL PAN BRIDGE CAP PACKING	2	
117	5117490340	BREATHER HEAD PACKING	1	
120	9019008180	BOLT	2	
121	9019608180	BOLT	1	
130	9092023080	PLUG; OIL GALLERY SCREW	1	
131	9095714080	SCREW PLUG PACKING	1	

ISUZU C240 ---TIMING GEAR ASSY.

TIMING GEAR ASSY.

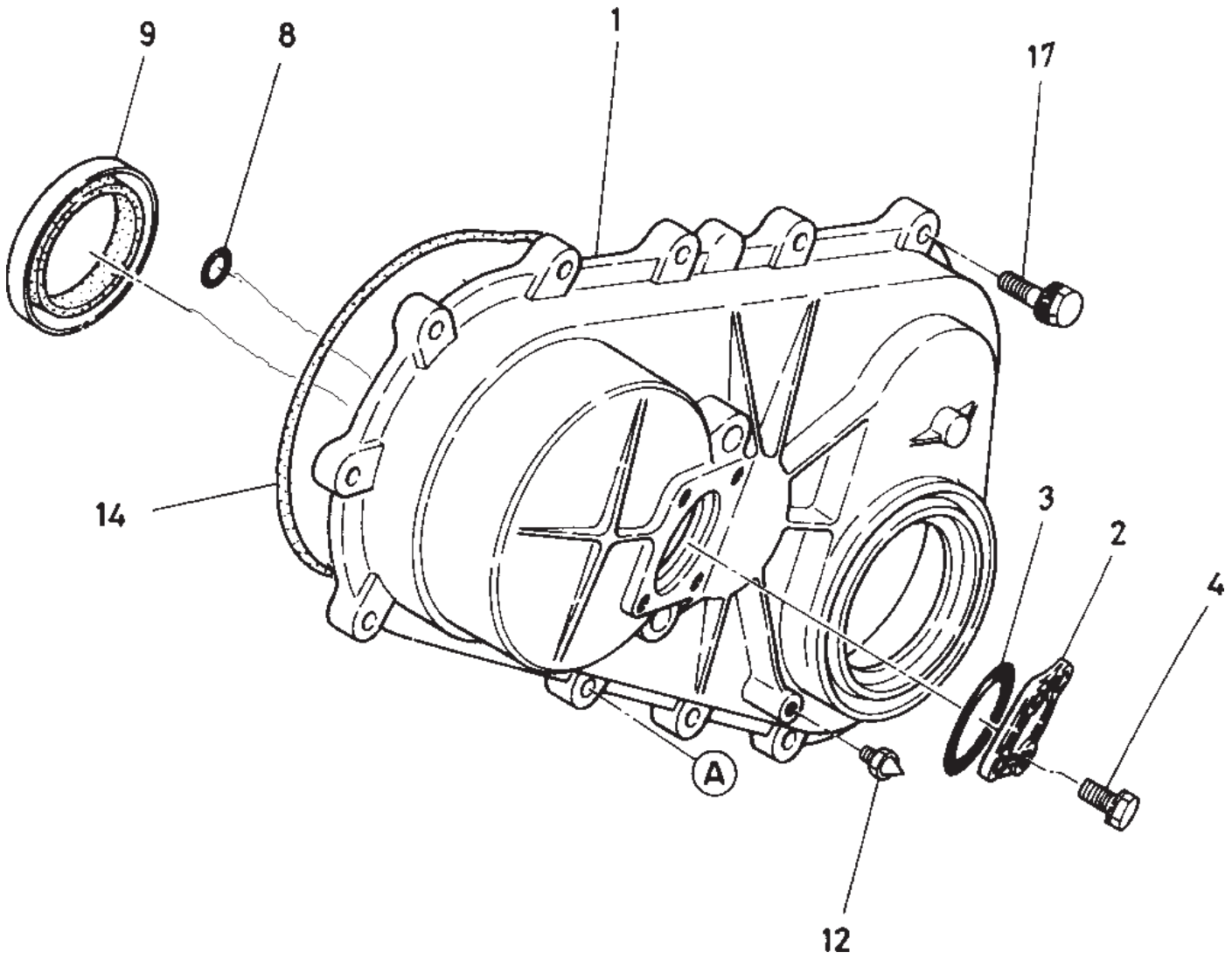

ISUZU C240 --- TIMING GEAR ASSY.

TIMING GEAR ASSY.

<u>NO.</u>	<u>PART NO.</u>	<u>ITEM</u>	<u>QTY.</u>	<u>REMARKS</u>
1	5113110282	TIMING GEAR CASE	1	
2	9113211480	GEAR CASE COVER	1	
3	9099206010	PACKING	1	
4	901906140	BOLT	4	
8	9113120460	PACKING	2	
9	5096250790	OIL SEAL	1	
12	9113270450	POINTER	1	
14	9113120340	PACKING	1	
17	9019108320	BOLT	9	

ISUZU C240 FLYWHEEL HOUSING ASSY.

FLYWHEEL HOUSING ASSY.

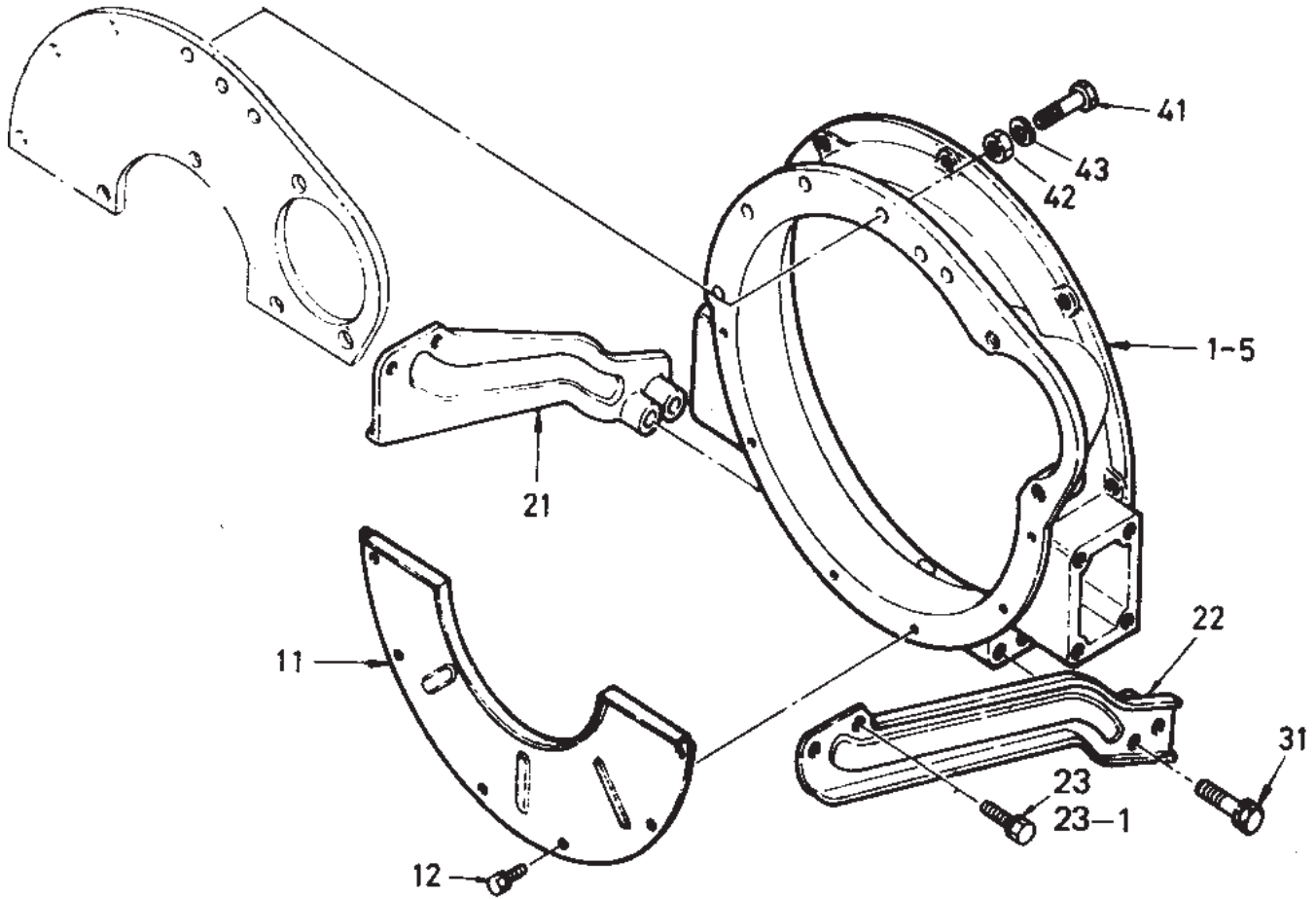

ISUZU C240 FLYWHEEL HOUSING ASSY.

FLYWHEEL HOUSING ASSY.

<u>NO.</u>	<u>PART NO.</u>	<u>ITEM</u>	<u>QTY.</u>	<u>REMARKS</u>
1-5	5113410191	FLYWHEEL HOUSING	1	
11	9113430391	COVER	1	
12	9019006120	BOLT	6	
21	5113490380	STIFFENER; RIGHT SIDE	1	
22	5113490370	STIFFENER; LEFT SIDE	1	
23	9019110200	BOLT	2	
23-1	9019110180	BOLT	2	
31	9019310450	BOLT	4	
41	9019110350	BOLT	3	
41	9010560400	BOLT	1	
42	9091104100	NUT	2	
46	9091505100	LOCKWASHER	2	

ISUZU C240 OIL PAN ASSY.

OIL PAN ASSY.

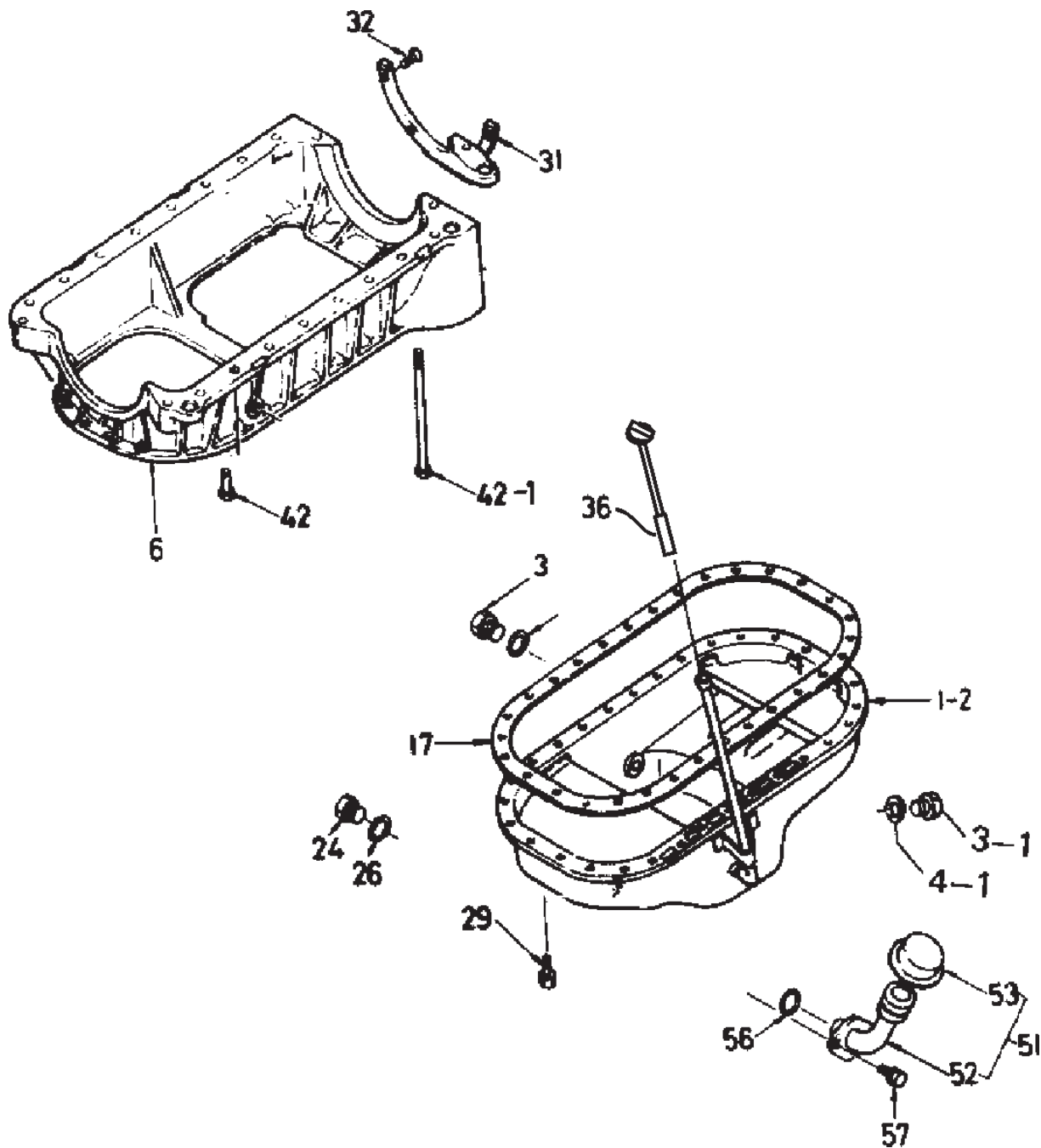

ISUZU C240 OIL PAN ASSY.

OIL PAN ASSY.

<u>NO.</u>	<u>PART NO.</u>	<u>ITEM</u>	<u>QTY.</u>	<u>REMARKS</u>
1-2	5113601832	OIL PAN ASSY.....	1	INCL. ITEMS W/*
3*	5096050050	OIL DRAIN PLUG, 3/8	1	
3-1	9992023200	OIL DRAIN PLUG	1	
4-1*	9097205600	O RING PACKING	1	
6	9112150810	CRANK CASE	1	
17	5113670040	OIL CASE PACKING	1	
24	9992023160	OIL THERMO PLUG	1	
26	9095714160	PLUG PACKING	1	
29	9019106160	BOLT	30	
31	9112193160	DISTRIBUTION PLATE	1	
32	9030906160	SCREW	4	
36	9117606090	OIL LEVEL GAUGE	1	
42	9019008220	BOLT	16	
42-1	9019708450	BOLT	4	
51	5117400870	OIL FILLER ASSY.....	1	INCL. ITEMS W/#
52#	5117410100	OIL FILLER	1	
53#	5117500021	OIL FILLER CAP	1	
56	9099207080	PACKING	1	
57	9019008200	BOLT	2	

ISUZU C240 ---OIL PUMP ASSY.

OIL PUMP ASSY.

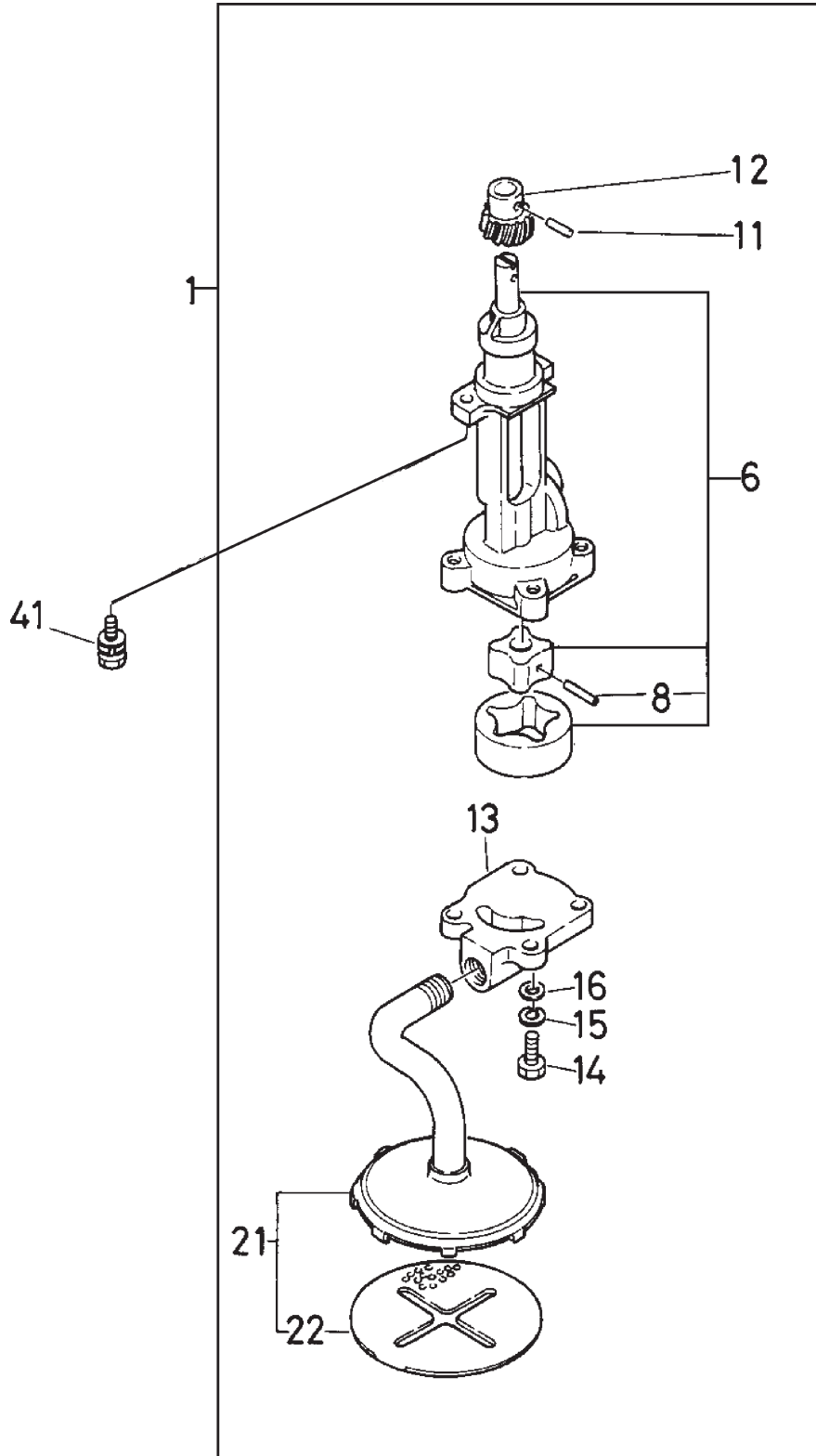

ISUZU C240 ---OIL PUMP ASSY.

OIL PUMP ASSY.

<u>NO.</u>	<u>PART NO.</u>	<u>ITEM</u>	<u>QTY.</u>	<u>REMARKS</u>
1	9131008010	OIL PUMP ASSY.	1 INCL. ITEMS W/*
6*	5131200040	ROTOR SET	1 INCL. ITEMS W/#
8*#	9131290170	PIN	1	
11*#	9098780840	PIN	1	
12*	9131280790	PINION	1	
13*	9131130771	COVER	1	
14*	9020408250	BOLT	4	
15*	9091505080	LOCKWASHER	4	
16*	9091505080	LOCKWASHER	4	
21*	9131401200	OIL STRAINER ASSY.....	1 INCL. ITEM W/%
22*%	9131430100	OIL STRAINER GAUZE	1	
41	9019708250	BOLT	2	

ISUZU C240 --- CRANKSHAFT, BRIDGE AND FLYWHEEL ASSY.

CRANKSHAFT, BRIDGE AND FLYWHEEL ASSY.

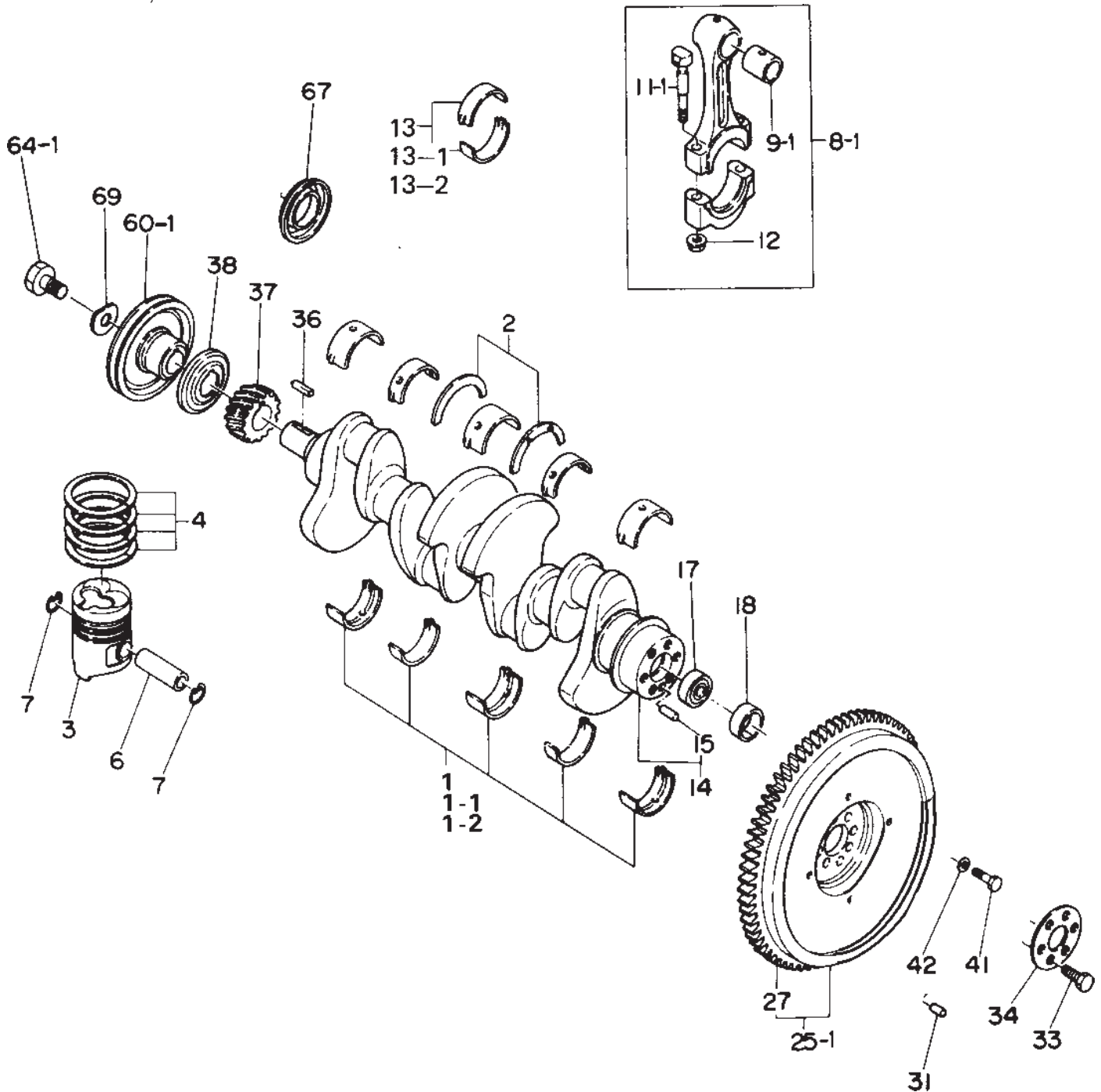

ISUZU C240 --- CRANKSHAFT, BRIDGE AND FLYWHEEL ASSY.

CRANKSHAFT, BRIDGE AND FLYWHEEL ASSY.

<u>NO.</u>	<u>PART NO.</u>	<u>ITEM</u>	<u>QTY</u>	<u>REMARKS</u>
1	5115100211	CRANK BEARING KIT;STD	1	
1-1	5115300211	CRANK BEARING KIT;-0.25	1	
1-2	5115400211	CRANK BEARING KIT;-0.50	1	
2	9115810570	THRUST BEARING	2	
3	5121112020	PISTON;STD	4	
4	5121210070	PISTON RING SET;STD	4	
6	5122110090	PISTON PIN	4	
7	5095870010	SNAP RING	8	
8-1	5122300390	CONNECTING ROD ASSY.	4	INCL. ITEMS W/@
9-1@	5122510050	SMALL END BUSHING	4	
11-1@	512350090	BOLT	8	
12@	5094090160	NUT	8	
13	8941422080	CONN. ROD BEARING SET;STD	4	REPLACES 5122710050
13-1	8941631740	BEARING SET;-0.25	4	
13-2	8941631750	BEARING SET;-0.50	4	
14	8941396690	CRANKSHAFT ASSY.	1	INCL. ITEM W/#
15#	9081612200	STRAIGHT PIN	1	
17	5098010010	RADIAL BALL BEARING	1	
25-1	5123301100	FLYWHEEL ASSY.	1	INCL. ITEM W/%
27%	9123330361	RING GEAR	1	Z=108
31	9098785320	STRAIGHT PIN	2	
33	5090001461	BOLT	6	
34	5123360100	WASHER	1	
36	9080307430	FEATHER KEY	1	
37	9125210420	CRANKSHAFT GEAR	1	Z=21
38	9123620390	THROWER	1	
60-1	9123736051	CRANKSHAFT PULLEY	1	
64-1	9098026060	BOLT	1	
67	9123736060	THROWER	1	
69	9123790160	WASHER	1	

ISUZU C240 --- OIL AND FUEL FILTER ASSY.

OIL AND FUEL FILTER ASSY.

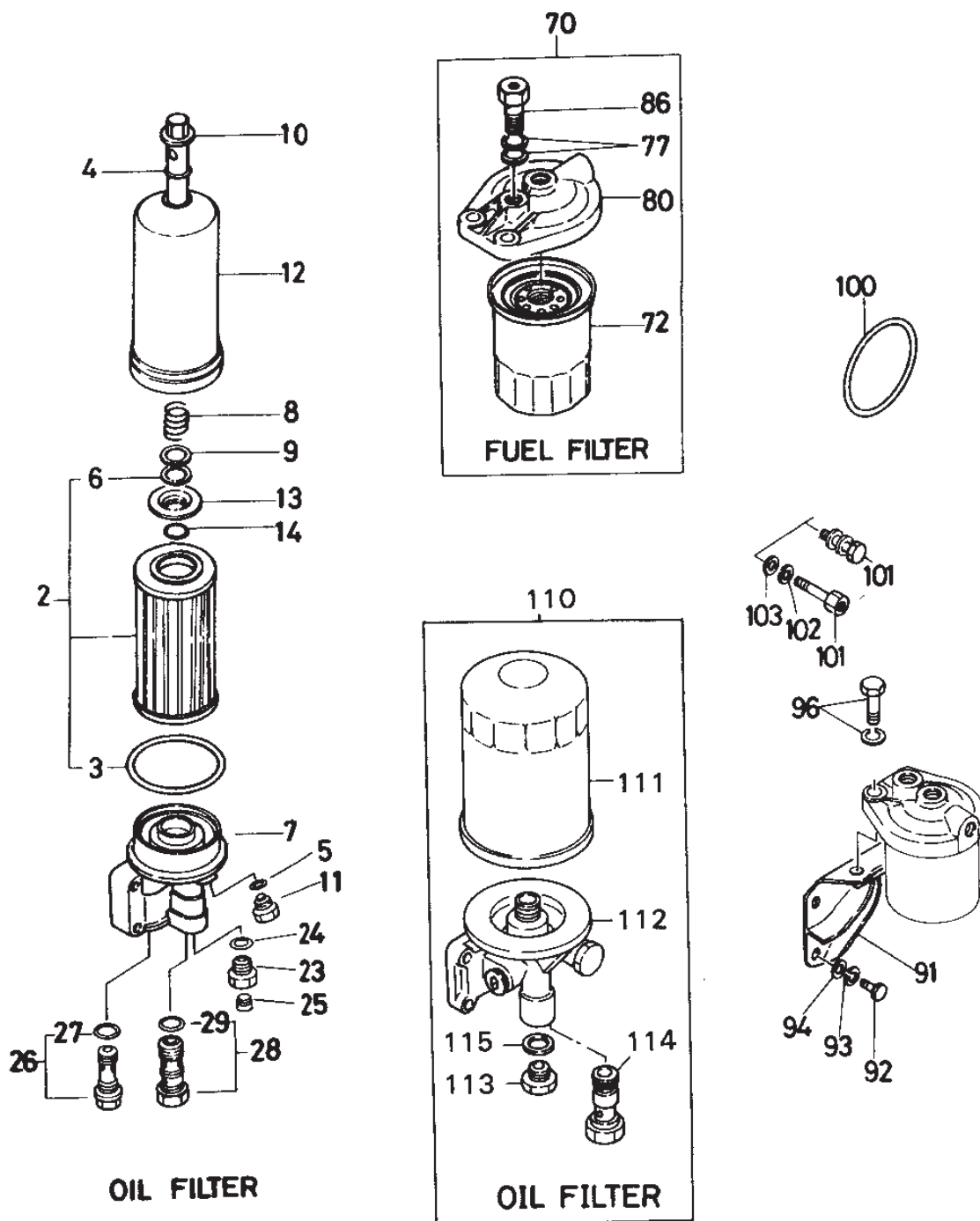

ISUZU C240 --- OIL AND FUEL FILTER ASSY.

OIL AND FUEL FILTER ASSY.

<u>NO.</u>	<u>PART NO.</u>	<u>ITEM</u>	<u>QTY.</u>	<u>REMARKS</u>
2	9885131071	OIL FILTER ELEMENT KIT	1	INCL. ITEMS W/*
3*	9132130350	O RING PACKING COVER	1	
4	9099211920	CENTER PIPE PACKING	1	
5-1	9099209780	DRAIN PIPE PACKING	1	
6*	9099221100	FELT RING	1	
7	9132121240	OIL FILTER COVER	1	
8	9099410540	COIL COMPRESSION SPRING	1	
9	9132390330	SPRING SEAT	1	
10	9132316030	CENTER PIPE	1	
11	9098621170	DRAIN PLUG	1	
12	9132110950	OIL FILTER BODY	1	
13	9132390320	ELEMENT HOLDER	1	
14	9099522170	SNAP RING	1	
23	9132260130	ADAPTER	1	
24	9099208410	PLUG PACKING	1	
25	9098640150	SCREW PLUG	1	
26	5132600080	SAFETY VALVE ASSY.	1	INCL. ITEM W/%
27%	1096231630	O RING PACKING	1	
28	5131600030	RELIEF VALVE ASSY.	1	INCL. ITEM W/#
29#	9099209750	RELIEF VALE PACKING	1	
70	8941434770	FUEL CART. FILTER ASSY.	1	INCL. ITEMS W/\$
72\$	8941434790	FUEL ELEMENT	1	
77\$	9095720140	OVERFLOW VALVE PACKING	2	
80\$	5132120750	FUEL FILTER COVER	1	
86\$	9132600561	OVERFLOW VALVE ASSY.	1	
91	9197518010	FUEL FILTER BRACKET	1	
92	9020608180	BOLT	2	
93	9091506080	LOCKWASHER	2	REPLACES 9091508080
94	9091645080	PLAIN WASHER	2	
96	9019110320	BOLT	2	
100	9132190570	OIL FILTER PACKING	1	
101-1	9019008350	BOLT	4	
110	8941208540	OIL FILTER ASSY.	1	INCL. ITEMS W/@
111@	8941564550	OIL FILTER CARTRIDGE	1	
112@	8941564540	OIL FILTER BODY	1	
113@	9132260090	ADAPTER	1	
114@	5131600030	RELIEF VALVE ASSY.	1	
115@	9099206200	PACKING ADAPTER	1	

ISUZU C240 --- OIL PIPE ASSY.

OIL PIPE ASSY.

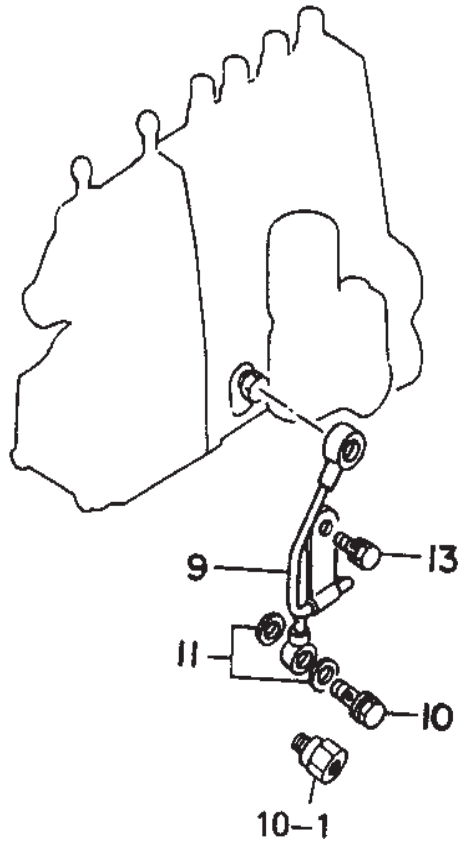
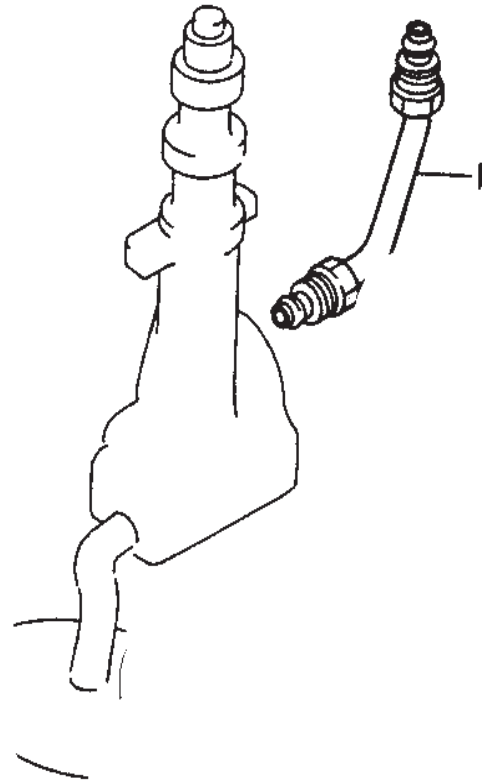
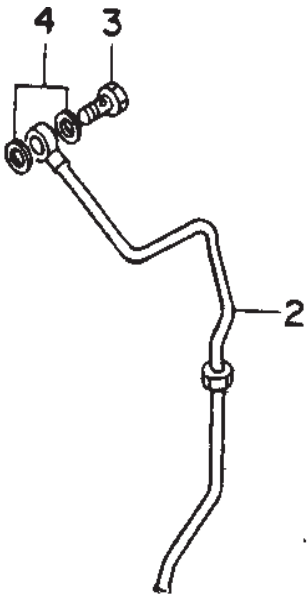

OIL PIPE ASSY.

<u>NO.</u>	<u>PART NO.</u>	<u>ITEM</u>	<u>QTY.</u>	<u>REMARKS</u>
1	9133119810	OIL PUMP ASSY.	1	
2	5133111141	ROCKER OIL FEED PIPE	1	
3	9099061051	BOLT	1	
4	9099209000	PACKING	2	
9	5133111740	OIL INJECTION PIPE	1	
10	5096750220	ADAPTER	1	
11	9095720080	PACKING	2	
13	901906120	BOLT	1	

ISUZU C240 --- WATER PUMP AND FAN ASSY.

WATER PUMP AND FAN ASSY.

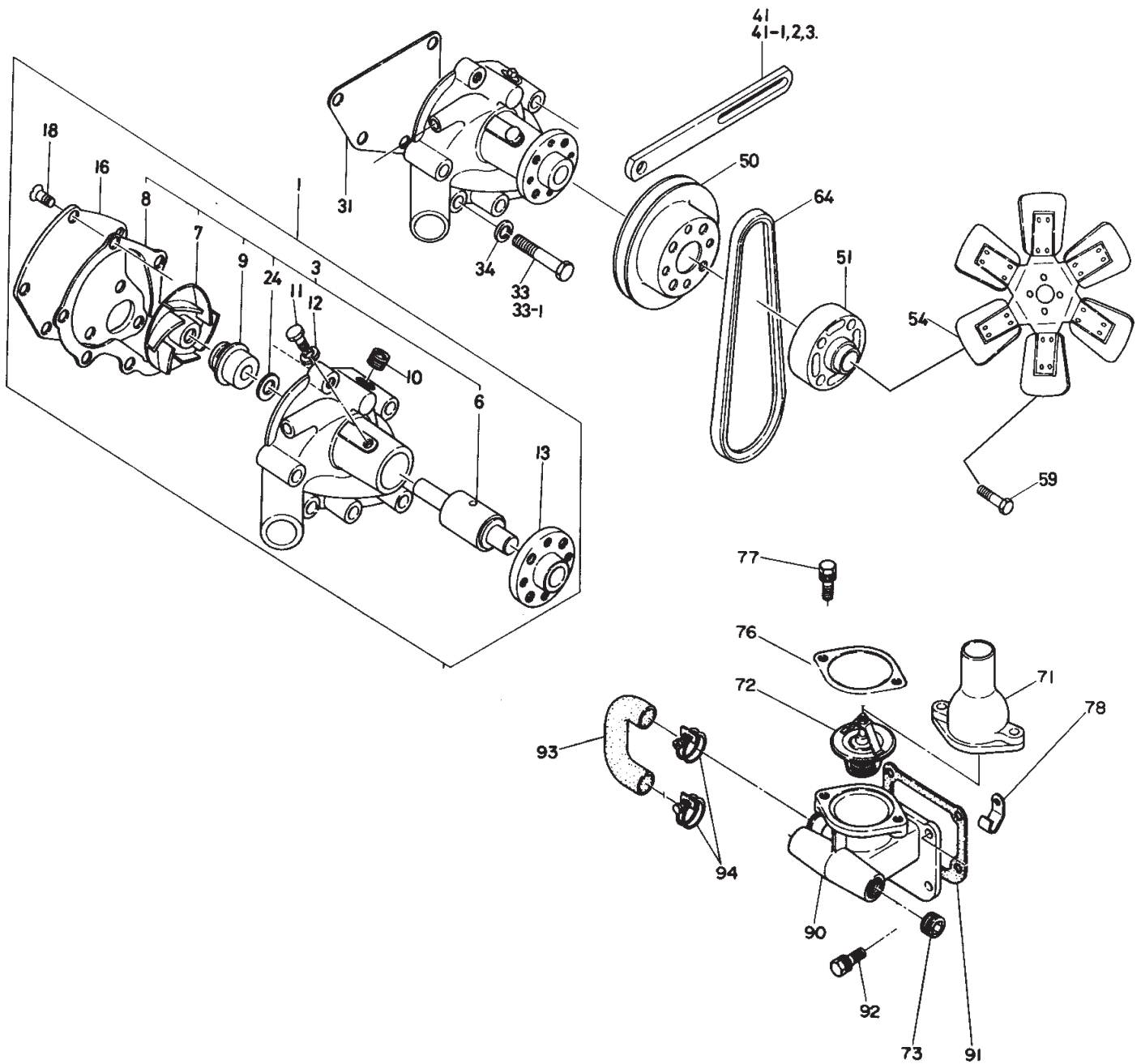

ISUZU C240 --- WATER PUMP AND FAN ASSY.

WATER PUMP AND FAN ASSY.

<u>NO.</u>	<u>PART NO.</u>	<u>ITEM</u>	<u>QTY.</u>	<u>REMARKS</u>
1	5136101673	WATER PUMP ASSY.	1	INCL. ITEMS W/*
3*	5878101391	WATER PUMP REPAIR KIT	1	INCL. ITEMS W.#
6*#	5136310080	BEARING UNIT	1	
7*#	9136210760	IMPELLER	1	
8*#	9136136070	PACKING	1	
9*#	8942366870	SEAL UNIT ASSY.	1	
10*#	5096050050	SCREW HEATER PLUG	1	
11*#	5098140010	SCREW	1	
12*#	9091505080	LOCK WASHER	1	
13*#	5136420640	FAN CENTER	1	
16*#	9136120530	WATER PUMP COVER	1	
18*#	9030408160	SCREW	1	
24*#	9136390010	BRIDGE UNIT THROWER	1	
31	9136140430	PACKING	1	
33	5090000890	BOLT	2	
33-1	5090000880	BOLT	4	
41	5136750390	ADJUSTING FAN BELT PLATE	1	
50	9136416160	FAN PULLEY	1	
51	9136420770	FAN SPACER	1	
54	9136608090	FAN ASSY.	1	
59	9019108450	BOLT	4	
64	5136710400	COOLING FAN BELT	1	
71	9137130380	OUTLET PIPE	1	
72	5137700221	THERMOSTAT	1	
73	5096050050	HEATER PLUG	1	
76	5096370130	PACKING	1	
77	9019708300	BOLT	2	
78	9099168190	CLIP	1	
90	9137168042	THERMOSTAT HOUSING	1	
91	5137430050	HOUSING PACKING	1	
92	9019708200	BOLT	2	
92	9019108220	BOLT	2	
93	9137211322	RUBBER BYPASS HOSE	1	
94	9099156441	HOSE CLIP	2	

ISUZU C240 --- INTAKE AND EXHAUST MANIFOLD ASSY.

INTAKE AND EXHAUST MAINIFOLD ASSY.

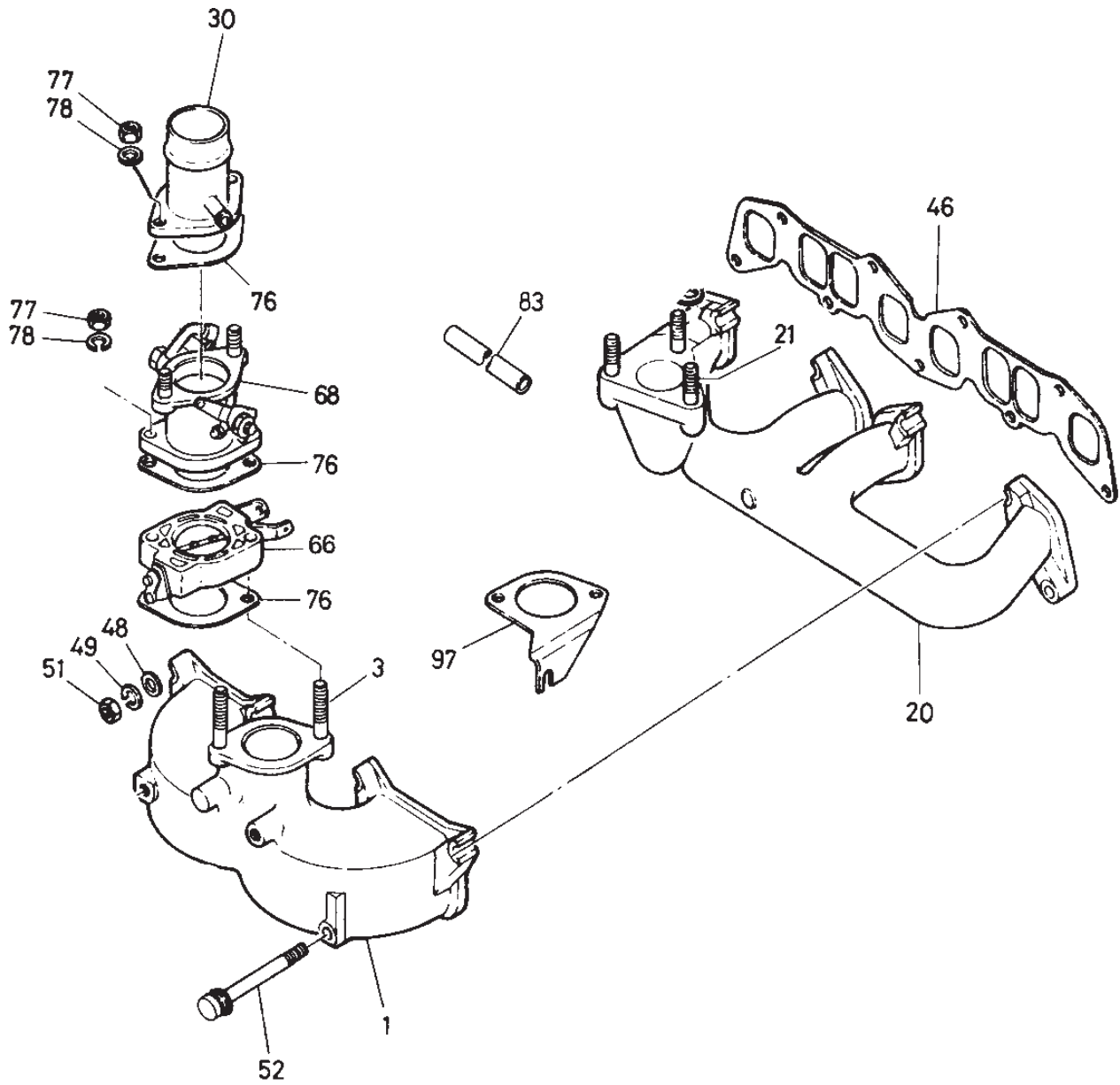

ISUZU C240 --- INTAKE AND EXHAUST MANIFOLD ASSY.

INTAKE AND EXHAUST MANIFOLD ASSY.

<u>NO.</u>	<u>PART NO.</u>	<u>ITEM</u>	<u>QTY.</u>	<u>REMARKS</u>
1	9141126954	INLET MANIFOLD	1	
3	9041108500	INTAKE STUD	2	
20	9141416142	EXHAUST MANIFOLD	1	
21	5093020020	EXHAUST STUD	1	
30	5141111290	INLET PIPE	2	
46	5141460180	GASKET	1	
48	9091646080	PLAIN WASHER	7	
49	9091505080	LOCK WASHER	7	
51	9091104080	NUT	7	
52	5090000870	BOLT	2	
66	5143101961	INTAKE SHUTTER ASSY.	1	
76	5096370150	THROTTLE VALVE PACKING	3	
77	9091104080	NUT	3	
78	9091505080	LOCK WASHER	2	
83	5093600530	HOSE	1	
97	5143340780	WIRE CONTROL BRACKET	1	

ISUZU C240 --- AIR CLEANER ASSY.

AIR CLEANER ASSY.

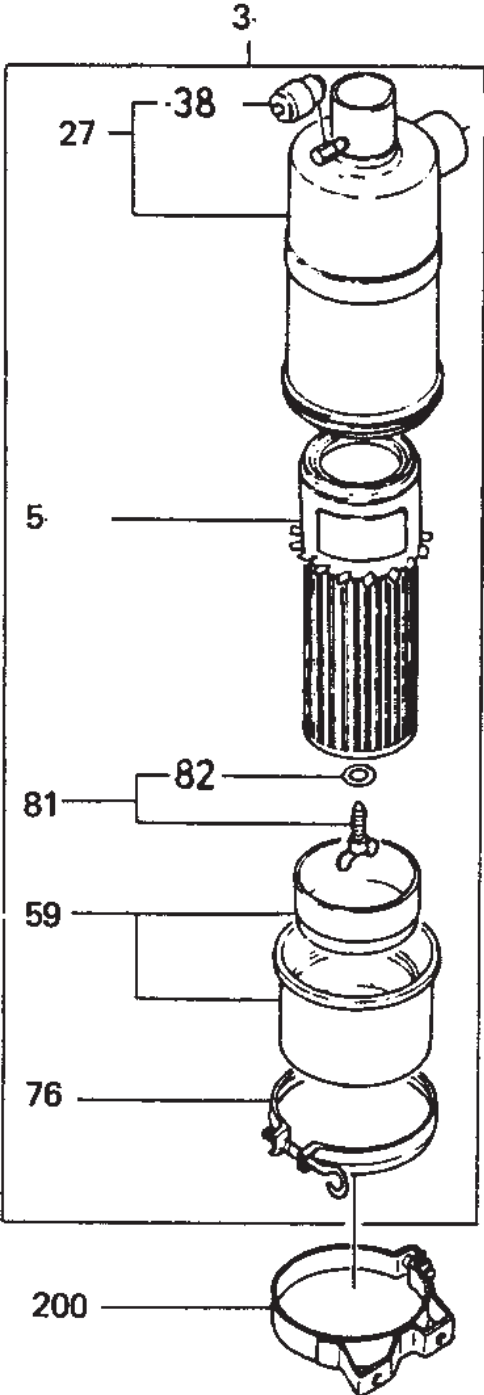

ISUZU C240 --- AIR CLEANER ASSY.

AIR CLEANER ASSY.

<u>NO.</u>	<u>PART NO.</u>	<u>ITEM</u>	<u>QTY.</u>	<u>REMARKS</u>
3	5142102130	AIR CLEANER ASSY.....	1	INCL. ITEMS W/*
5*	5142150140	ELEMENT	1	
27*	5142110670	COVER	1	
38*	9142191410	INDICATOR	1	
59*	5142120560	DUST W/BAFFLE PAN	1	
76*	5142170040	CLAMP	1	
81*	9142170620	BOLT W/GASKET WASHER	1	INCL. ITEMS W/#
82*#	9142191770	GASKET WASHER	3	
200	9142176020	BAND ASSY. W/BOLT	2	

ISUZU C240 --- ENGINE FOOT ASSY.

ENGINE FOOT ASSY.

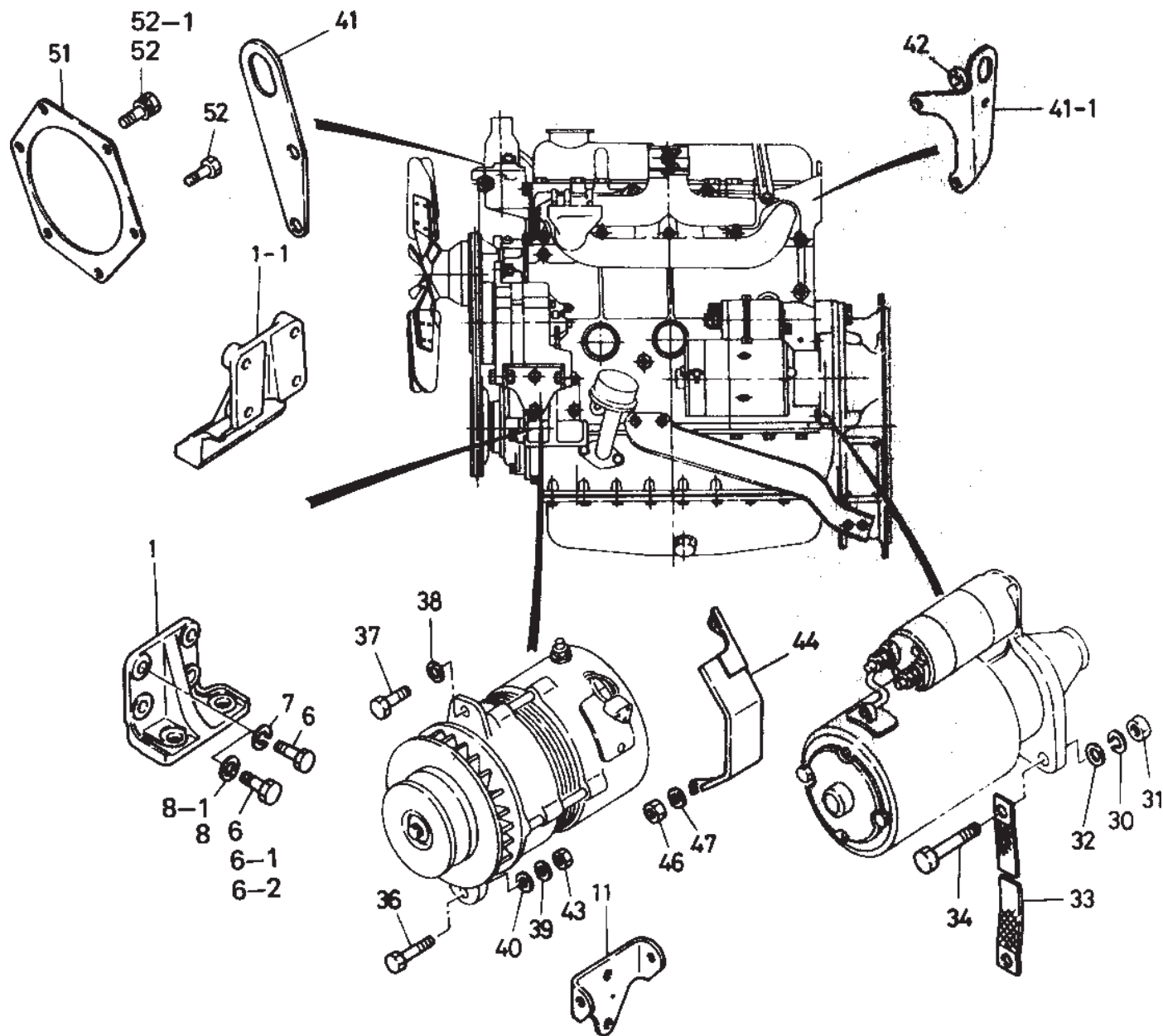

ISUZU C240 --- ENGINE FOOT ASSY.

ENGINE FOOT ASSY.

<u>NO.</u>	<u>PART NO.</u>	<u>ITEM</u>	<u>QTY.</u>	<u>REMARKS</u>
1	9117712070	ENGINE FOOT, RIGHT SIDE	1	
1-1	5117710501	ENGINE FOOT, LEFT SIDE	1	
6	9029510250	FOOT BOLT, RIGHT SIDE	4	
6-1	9029510250	BOLT FOOT, LEFT SIDE	1	
6-2	9029560400	BOLT FOOT, LEFT SIDE	3	
8	9098518660	PLAIN WASHER	8	
11	5197110010	ALTERNATOR BRACKET	1	
30	9091505080	LOCKWASHER	1	
31	9091114080	NUT	1	
32	9091605120	PLAIN WASHER	1	
33	9829315110	CABLE ASSY.	1	
34	9019312450	BOLT	2	
36	9010558320	BOLT	2	
37	9019108400	BOLT	1	
38	9091647080	PLAIN WASHER	1	
39	9091505080	LOCKWASHER	2	
40	9091605080	PLAIN WASHER	2	
41	9117770750	FRONT LIFTING HANGER	1	
41-1	9117771360	REAR LIFTING HANGER	1	
42	9141491730	REAR HANGER PIECE	2	
43	9091105080	NUT	2	
44	5197190060	ALTERNATOR FAN COVER	1	
46	9091104080	NUT	1	
47	9091505080	LOCKWASHER	1	
51	5113190570	FRONT PLATE PACKING	1	
52	8942059870	BOLT	2	
52-1	9019108320	BOLT	4	

ISUZU C240 --- INJECTION PUMP ASSY.

INJECTION PUMP ASSY.

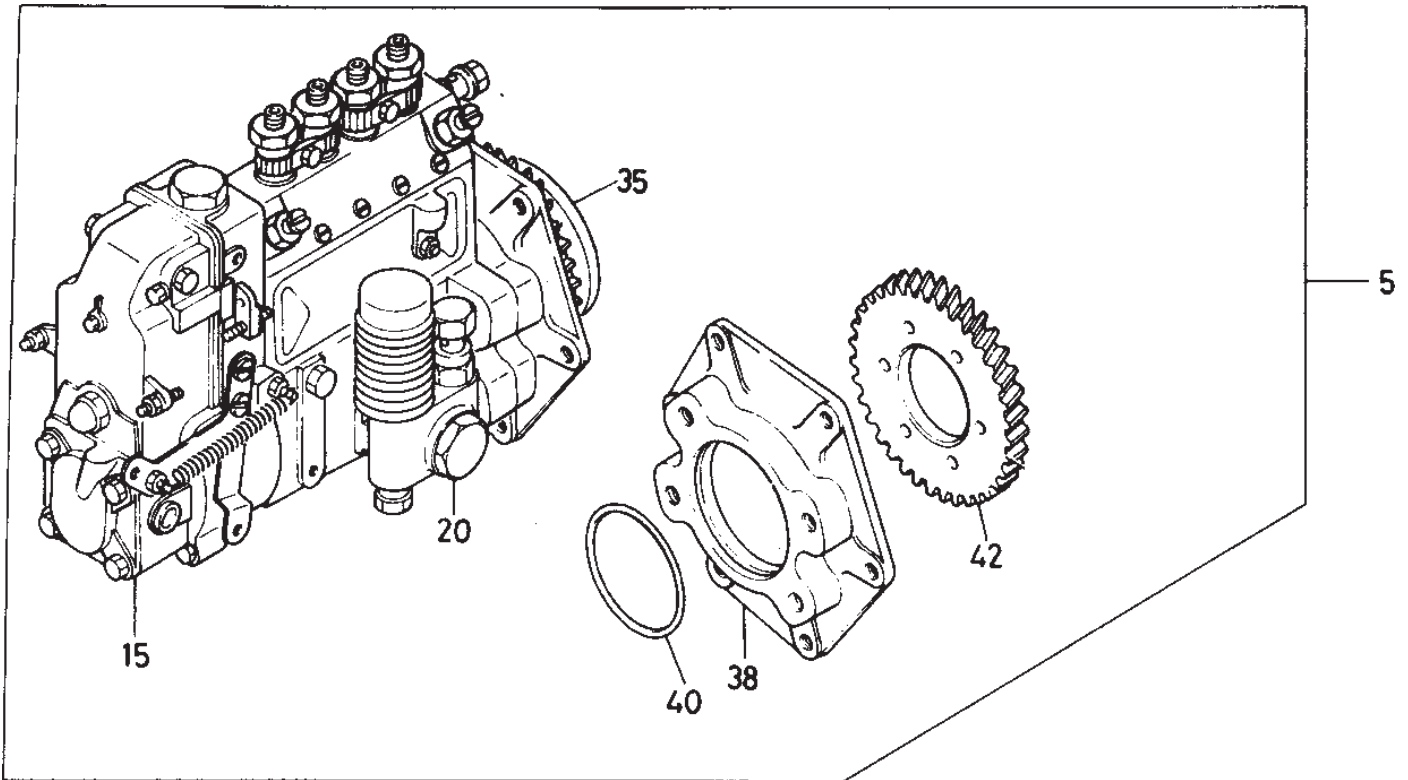

ISUZU C240 --- INJECTION PUMP ASSY.

INJECTION PUMP ASSY.

<u>NO.</u>	<u>PART NO.</u>	<u>ITEM</u>	<u>QTY.</u>	<u>REMARKS</u>
5	8943864440	INJECTION PUMP ASSY.	1	REPLACES 5156010252 INCL. ITEMS W/*
15*	5157201400	GOVERNOR ASSY.	1	
20*	8941415340	FEED PUMP ASSY.	1	
35*	5157400720	AUTOMATIC TIMER	1	
38*	9197510790	INJ. PUMP SPACER BRACKET	1	
40*	9099205760	O RING PACKING	1	
42*	5125240660	INJ. PUMP GEAR	1	

ISUZU C240 --- ELECTRICAL PARTS

ELECTRICAL PARTS

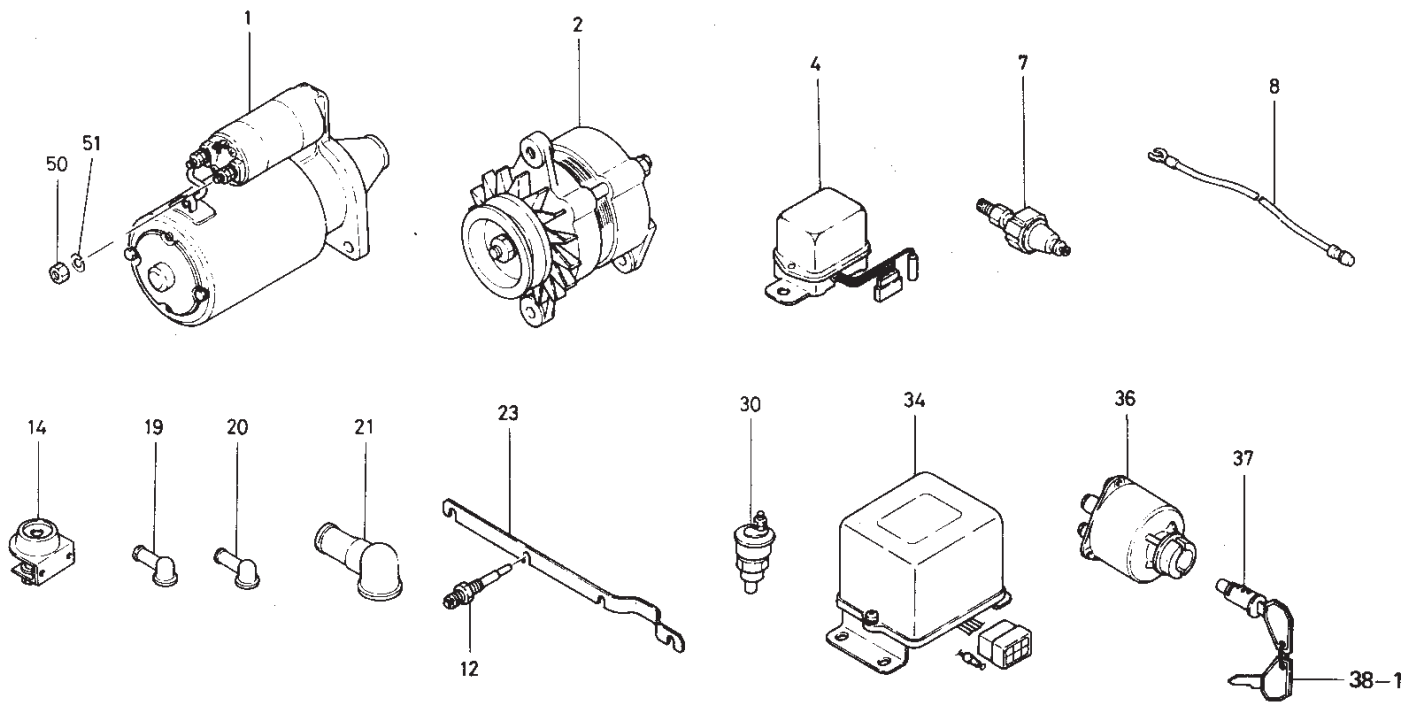

ISUZU C240 --- ELECTRICAL PARTS

ELECTRICAL PARTS

<u>NO.</u>	<u>PART NO.</u>	<u>ITEM</u>	<u>QTY.</u>	<u>REMARKS</u>
1	5811000801	STARTER	1	
2	5812003410	ALTERNATOR	1	UP TO OCT. 1992
	9822007640	ALTERNATOR	1	OCT. 1992~
4	9822531070	REGULATOR	1	
8	9829317430	CABLE ASSY.	1	
12	9825119780	GLOW PLUG	4	
14	9825301090	CONTROL	1	
19	9829513240	INSULATOR CAP	2	
20	9829513250	INSULATOR CAP	2	
21	9829513320	CABLE CAP	1	
23	9197326100	CONNECTOR	1	
30	5824500140	SWITCH	1	
34	5825500190	EMERGENCY RELAY	1	
36	1823100080	STARTER SWITCH	1	
38-1	1823170070	KEY	1	
50	9091114080	NUT	1	
51	9091505080	LOCK WASHER	1	

ACCESSORIES

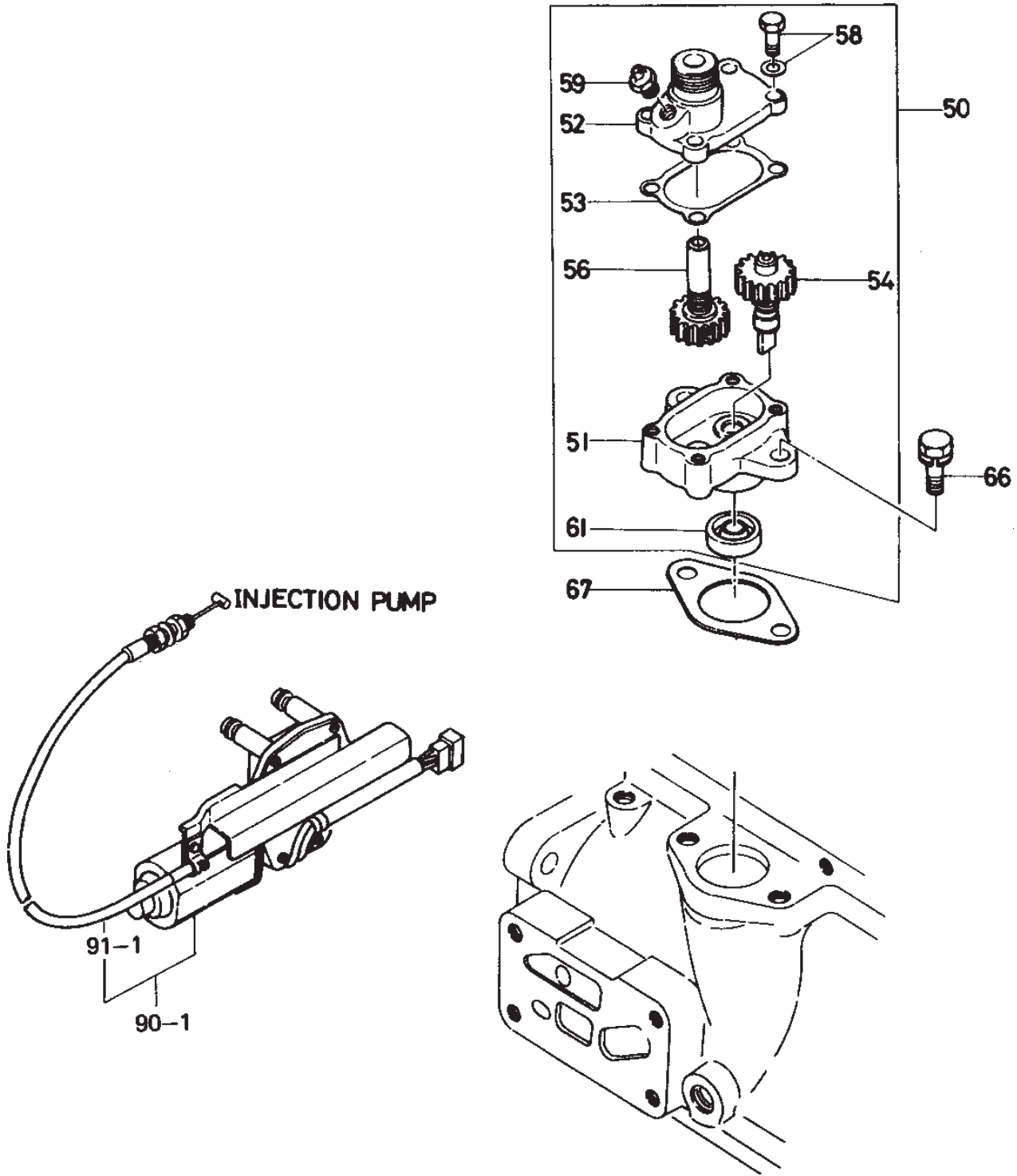

ISUZU C240 --- ACCESSORIES

ACCESSORIES

<u>NO.</u>	<u>PART NO.</u>	<u>ITEM</u>	<u>QTY.</u>	<u>REMARKS</u>
50	5193100060	DRIVE ASSY.	1 INCL. ITEMS W/*
51*	9193110240	CASE	1	
52*	9193110200	COVER	1	
53*	9193120060	PACKING	1	
54*	9193160270	GEAR	1	
56*	9193160170	GEAR	1	
58*	9019006160	BOLT	4	
59*	9090310100	NIPPLE	1	
61*	9099243550	OIL SEAL	1	
66	9019008220	BOLT	2	
67	9099211070	PACKING	1	
91	5819000020	STOPPER ASSY.	1	
91-1	5828480360	CABLE ASSY.	1	

ISUZU C240 ---INJECTION PUMP COMP. ASSY.

INJECTION PUMP COMP. ASSY.

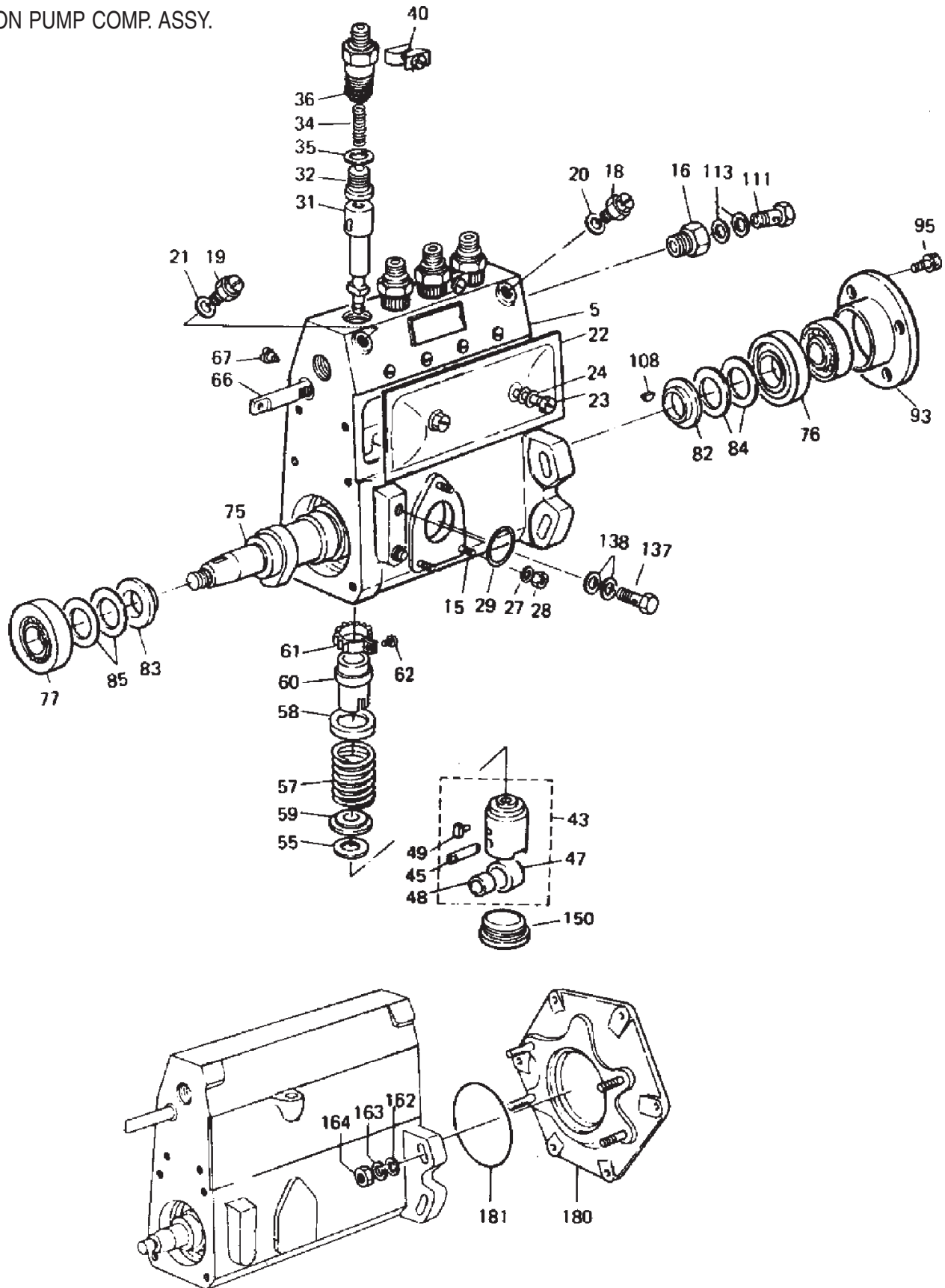

ISUZU C240 --- INJECTION PUMP COMP. ASSY.

INJECTION PUMP COMP. ASSY.

<u>NO.</u>	<u>PART NO.</u>	<u>ITEM</u>	<u>QTY.</u>	<u>REMARKS</u>
5	5156110460	HOUSING ASSY.	1	INCL. ITEMS W/*
15*	9812151150	STUD	3	
16*	9812350170	ADAPTER	1	
18*	1156190240	BOLT	2	
20*	1156390080	GASKET	1	
21*	1156390080	GASKET	1	
22*	5156120080	COVER	1	
23*	1156190030	SCREW	2	
24*	9812151440	GASKET	2	
27*	9091505060	LOCKWASHER	3	
28*	9091104060	NUT	3	
29*	1096230130	PACKING	1	
31*	5156310090	PLUNGER ASSY.	4	
32*	9812411030	DELIVERY VALVE	4	
34*	5156430020	DELIVERY VALVE SPRING	4	
35*	9812450140	GASKET	4	
36*	5156440050	HOLDER	4	
40*	5156490160	PLATE ASSY.	2	
43*	9812212230	TAPPET ASSY.	4	INCL. ITEMS W/#
45*#	9812212200	PIN TAPPET	4	
47*#	1156220030	TAPPET ROLLER	4	
48*#	1156290010	TAPPET BUSHING	4	
49*#	5156190410	TAPPET GUIDE	4	
55*	5156190340	TAPPET SHIM	A/R	T=0.30
55-1*	5156190350	TAPPET SHIM	A/R	T=0.40
55-2*	5156190360	TAPPET SHIM	A/R	T=0.50
55-3*	5156190010	TAPPET SHIM	A/R	T=0.60
55-4*	5156190020	TAPPET SHIM	A/R	T=0.70
55-5*	5156190030	TAPPET SHIM	A/R	T=0.80
55-6*	5156190040	TAPPET SHIM	A/R	T=0.90
55-7*	5156190050	TAPPET SHIM	A/R	T=1.00
55-8*	5156190070	TAPPET SHIM	A/R	T=1.10
55-9*	5156190080	TAPPET SHIM	A/R	T=1.20
55-10*	5156190090	TAPPET SHIM	A/R	T=1.30
55-11*	5156190100	TAPPET SHIM	A/R	T=1.40
55-12*	5156190110	TAPPET SHIM	A/R	T=0.55
55-13*	5156190120	TAPPET SHIM	A/R	T=0.65
55-14*	5156190130	TAPPET SHIM	A/R	T=0.75
55-15*	5156190150	TAPPET SHIM	A/R	T=0.85
55-16*	9812350420	TAPPET SHIM	A/R	T=0.95
55-17*	9812350430	TAPPET SHIM	A/R	T=1.05
55-18*	9812350440	TAPPET SHIM	A/R	T=1.15
55-19*	9812350450	TAPPET SHIM	A/R	T=1.25
55-20*	5156190250	TAPPET SHIM	A/R	T=0.25

ISUZU C240 --- INJECTION PUMP COMP. ASSY.

INJECTION PUMP COMP. ASSY.

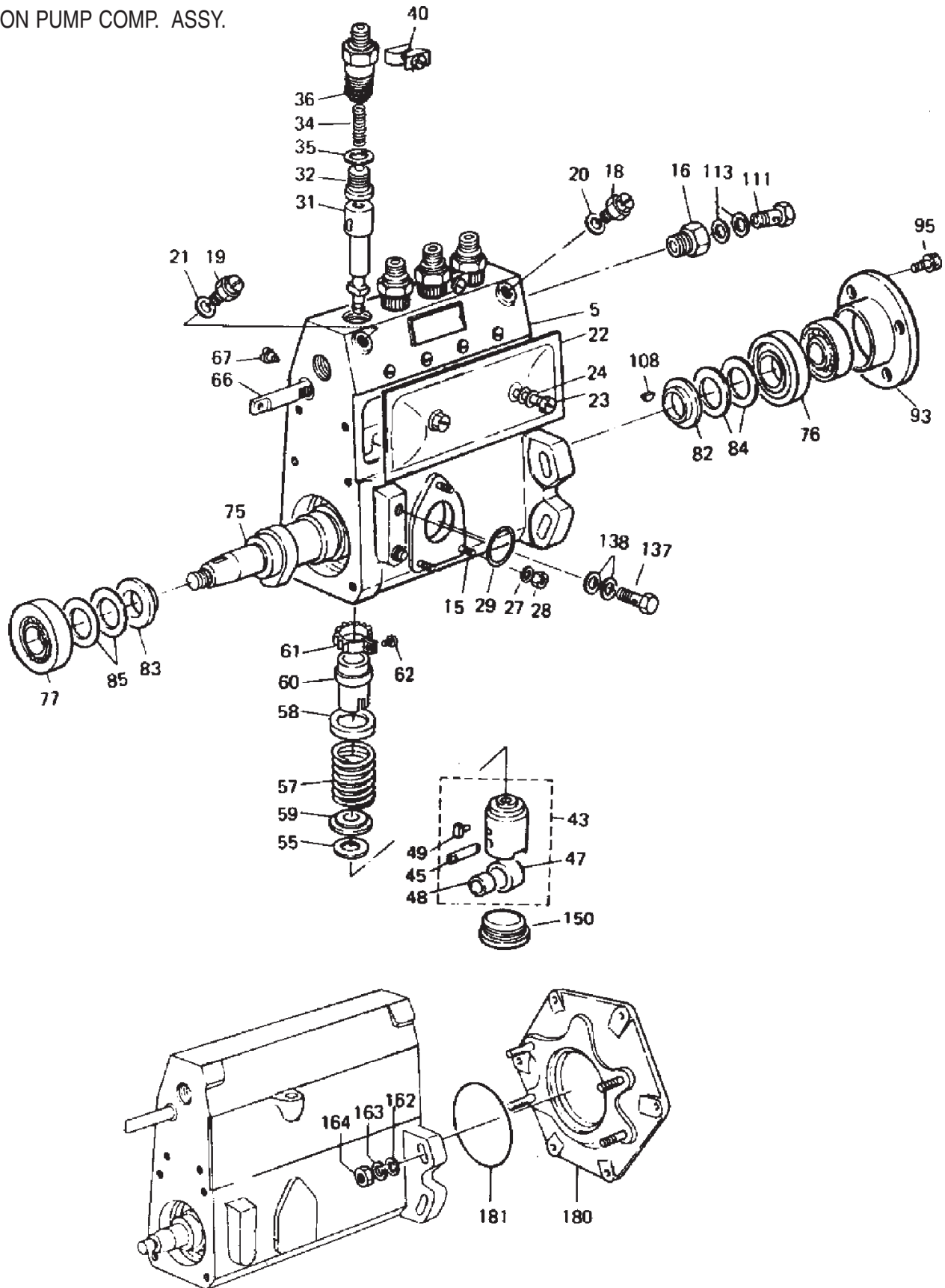

ISUZU C240 --- INJECTION PUMP COMP. ASSY.

INJECTION PUMP COMP. ASSY.

<u>NO.</u>	<u>PART NO.</u>	<u>ITEM</u>	<u>QTY.</u>	<u>REMARKS</u>
55-21*	5156190260	TAPPET SHIM	A/R	T=0.26
55-22*	5156190270	TAPPET SHIM	A/R	T=0.35
55-23*	5156190370	TAPPET SHIM	A/R	T=0.45
55-24*	5156191060	TAPPET SHIM	A/R	T=1.50
55-25*	5156191070	TAPPET SHIM	A/R	T=1.60
55-26*	5156191080	TAPPET SHIM	A/R	T=1.35
55-27*	5156191090	TAPPET SHIM	A/R	T=1.45
55-28*	5156191100	TAPPET SHIM	A/R	T=1.55
57*	9812314070	PLUNGER SPRING	4	
58*	9812350150	PLUNGER SEAT	4	
59*	9812350210	PLUNGER SEAT	4	
60*	9812250580	SLEEVE	4	
61*	9812250570	PINION	4	
62*	9812350030	SCREW	4	
66*	5156370020	CONTROL RACK	1	
67*	1156390030	SCREW	1	
75*	5156210170	CAM SHAFT	1	
73*	9812232010	BALL BEARING, CAMSHAFT	1	
76-2*	9000906770	BALL BEARING, CAMSHAFT	1	
77*	9812232010	BALL BEARING, GOV. SIDE	1	
77-2*	9000906770	BALL BEARING, GOV. SIDE	1	
82*	9812250470	CAMSHAFT RING	1	
83*	9812250470	CAM RING, GOV. SIDE	1	
84*	5156290150	CAMSHAFT SHIM	A/R	T=0.10
84-1*	5156290160	CAMSHAFT SHIM	A/R	T=0.12
84-2*	5156290170	CAMSHAFT SHIM	A/R	T=0.14
84-3*	5156290180	CAMSHAFT SHIM	A/R	T=0.16
84-4*	5156290190	CAMSHAFT SHIM	A/R	T=0.18
84-5*	5156290200	CAMSHAFT SHIM	A/R	T=0.50
84-6*	5156190380	CAMSHAFT SHIM	A/R	T=1.00
84-7*	5156290210	CAMSHAFT SHIM	A/R	T=0.30
84-8*	5156190390	CAMSHAFT SHIM	A/R	T=0.70
84-9*	1156190900	CAMSHAFT SHIM	A/R	T=1.40
85*	5156290150	CAMSHAFT SHIM	A/R	T=0.10
85-1*	5156290160	CAMSHAFT SHIM	A/R	T=0.30
85-2*	5156290170	CAMSHAFT SHIM	A/R	T=0.14
85-3*	5156290180	CAMSHAFT SHIM	A/R	T=0.16
85-4*	5156290190	CAMSHAFT SHIM	A/R	T=0.18
85-5*	5156290200	CAMSHAFT SHIM	A/R	T=0.50
85-6*	5156190380	CAMSHAFT SHIM	A/R	T=1.00
85-7*	5156290210	CAMSHAFT SHIM	A/R	T=0.30
85-8*	5156190390	CAMSHAFT SHIM	A/R	T=0.70
85-9*	1156190900	CAMSHAFT SHIM	A/R	T=1.40
93*	5156290050	HOUSING COVER	1	
95*	9019006140	BOLT	4	

ISUZU C240 --- INJECTION PUMP COMP. ASSY.

INJECTION PUMP COMP. ASSY.

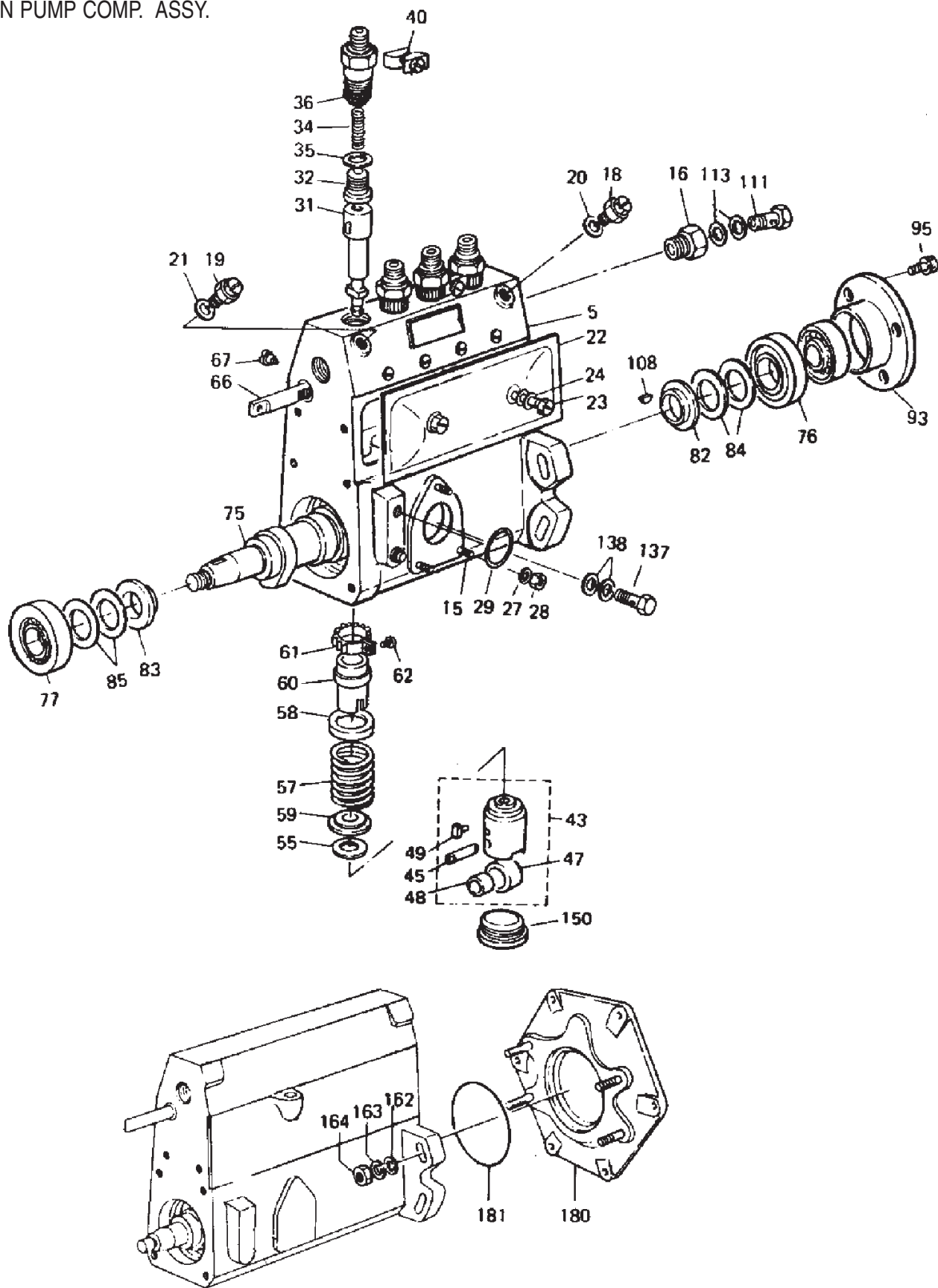

ISUZU C240 --- INJECTION PUMP COMP. ASSY.

INJECTION PUMP COMP. ASSY.

<u>NO.</u>	<u>PART NO.</u>	<u>ITEM</u>	<u>QTY.</u>	<u>REMARKS</u>
108*	9812214110	KEY	1	
111*	1156190820	BOLT	1	
113*	1157590010	PACKING	2	
137*	9097060370	BOLT	1	
138*	1096350070	PACKING	2	
150*	9812150780	TAPPET PLUG	4	
162*	9091606100	PLAIN WASHER	4	
163*	9091505100	LOCK WASHER	4	
164*	5156390020	NUT	4	
180*	9197510790	BRACKET	1	
181*	9099205760	O RING PACKING	1	

ISUZU C240 ---GOVERNOR COMP. ASSY.

GOVERNOR COMP. ASSY.

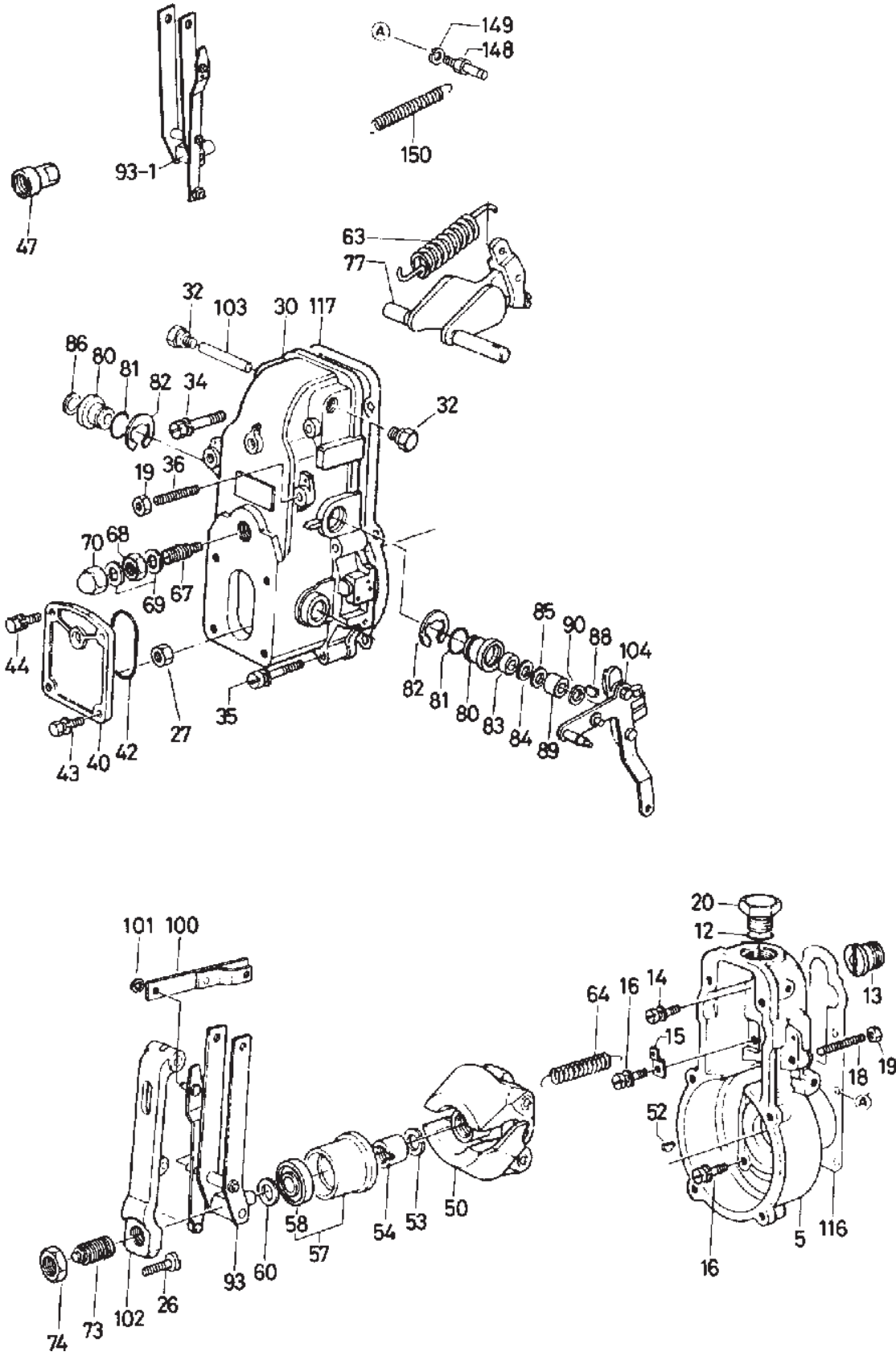

ISUZU C240 --- GOVERNOR COMP. ASSY.

GOVERNOR COMP. ASSY.

<u>NO.</u>	<u>PART NO.</u>	<u>ITEM</u>	<u>QTY.</u>	<u>REMARKS</u>
5	1157210040	HOUSING	1	INCL. ITEMS W/*
12*	1157290150	O RING PACKING	1	
13*	9813150650	ADAPTER	1	
14*	9019008180	BOLT	1	
15*	9813253970	HOUSING PLATE	1	
16*	901906140	BOLT	6	
18*	5157291230	SCREW	1	
19*	9813252370	NUT	2	
20*	1157290380	HOUSING PLUG	1	
26*	9813251820	SCREW	1	
27*	9813261120	NUT	1	
30*	5157210080	COVER	1	
32*	5157290530	PLUG	2	
34*	5157290540	BOLT	2	
35*	5157290330	BOLT	2	
36*	5157291230	SCREW	1	
40*	9813211860	COVER	1	
42*	9813919070	O RING PACKING	1	
43*	5157290630	BOLT	2	
44*	9019006160	BOLT	2	
47*	9812350340	CAP	1	
50*	9813213230	FLYWEIGHT ASSY.	1	
52*	5156190490	KEY	1	
53*	5157290340	LOCK WASHER	1	
54*	9813250860	NUT	1	
57*	5157190080	SLEEVE	1	INCL. ITEM W/#
58*#	9000902290	BEARING	1	
60*	9813250880	SHIM	A/R	T=0.20
60-1*	9813255510	SHIM	A/R	T=0.30
60-2*	9813255520	SHIM	A/R	T=0.40
60-3*	9813255530	SHIM	A/R	T=1.00
63*	9813222100	GOVERNOR SPRING	1	
64*	5157230820	LINK SPRING	1	
67*	1157230200	CAPSULE SPRING	1	
68*	9813932040	NUT	1	
69*	1156390080	GASKET	2	
73*	9813216360	CAPSULE SPRING	1	
74*	9008130230	NUT	1	
77*	9813217210	LEVER	1	
80*	9813250990	BUSHING	2	
81*	9813212050	O RING PACKING	2	
82*	9091854150	SNAP RING	2	

ISUZU C240 --- GOVERNOR COMP. ASSY.

GOVERNOR COMP. ASSY.

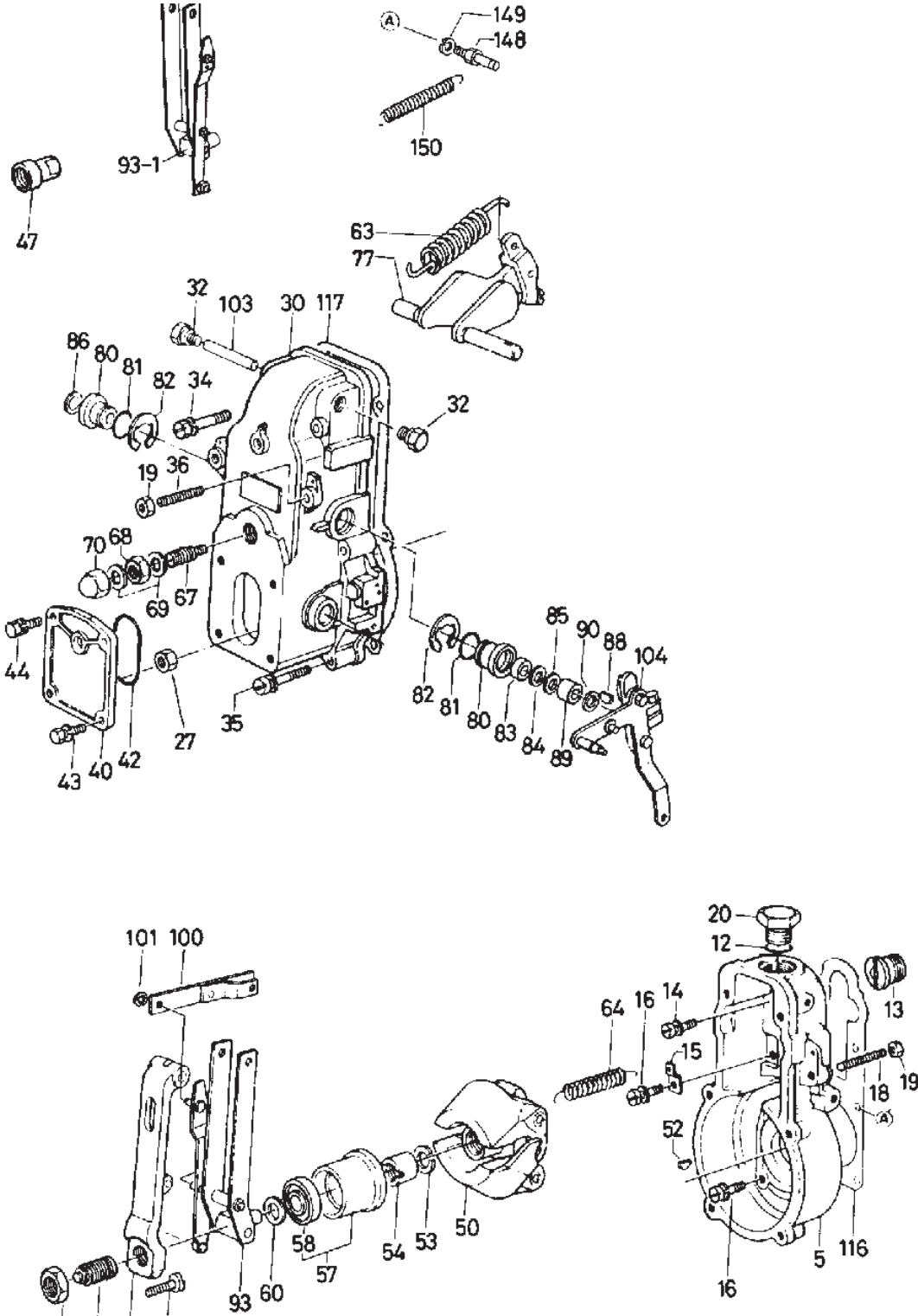

ISUZU C240 --- GOVERNOR COMP. ASSY.

GOVERNOR COMP. ASSY.

<u>NO.</u>	<u>PART NO.</u>	<u>ITEM</u>	<u>QTY.</u>	<u>REMARKS</u>
83*	9813212200	OIL SEAL	1	
84*	9813251730	SHIM	1	T=0.50
85*	9813250970	SHIM	A/R	T=0.30
86*	9813253180	PLUG	1	
88*	9813250300	KEY	1	
89*	9813913070	COLLAR	1	
90*	9813254880	WASHER	A/R	
93*	5157250160	GUIDE LEVER ASSY.	1	
100*	9813217130	LINK	1	
101*	1157290230	SNAP RING	1	
102*	5157250170	TENSION LEVER	1	
103*	9813250620	PIN	1	
104*	5157250490	LEVER	1	
116*	1157290010	GASKET	1	
117*	1157290020	GASKET	1	
148*	5157291120	BOLT	1	
150*	5157230880	SPRING	1	

ISUZU C240 --- FEED PUMP COMP. ASSY.

FEED PUMP COMP. ASSY.

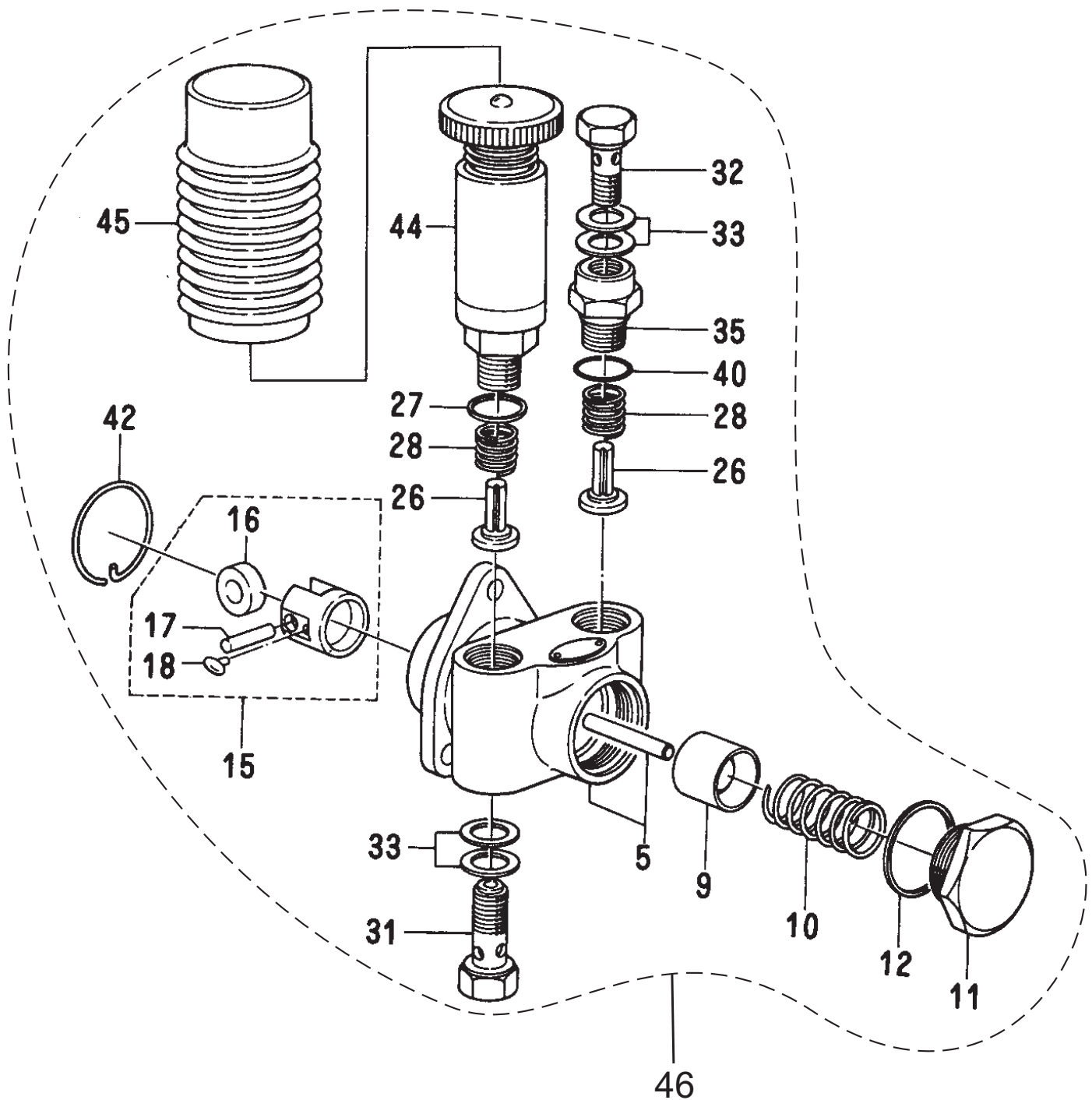

ISUZU C240 --- FEED PUMP COMP. ASSY.

FEED PUMP COMP. ASSY.

<u>NO.</u>	<u>PART NO.</u>	<u>ITEM</u>	<u>QTY.</u>	<u>REMARKS</u>
5*	5157510120	HOUSING	1	
9*	9813512050	PISTON	1	
10*	9813513030	SPRING	1	
11*	9813550230	PLUG	1	
12*	9813550350	GASKET	1	
15*	5157540010	TAPPET ASSY.....	1	INCLUDES ITEMS W/ #
16*#	9813514030	ROLLER	1	
17*#	9813514100	PIN	1	
18*#	1157590020	GUIDE	2	
26*	9813516020	CHECK VALVE	2	
27*	1096230160	GASKET	1	
28*	9813517020	SPRING	2	
31*	9099063260	BOLT	1	
32*	1156190820	BOLT	1	
33*	1157590010	PACKING	4	
35*	1157590030	ADAPTER	1	
40*	1096230160	PACKING	1	
42*	9813550250	RING	1	
44*	9813521040	PUMP	1	REPLACES 5157610050
45*	9813550330	COVER	1	
46	8941415340	PUMP ASSY FEED	1	INCLUDES ITEMS W/ *

ISUZU C240 --- AUTO TIMER COMP. ASSY.

AUTO TIMER COMP. ASSY.

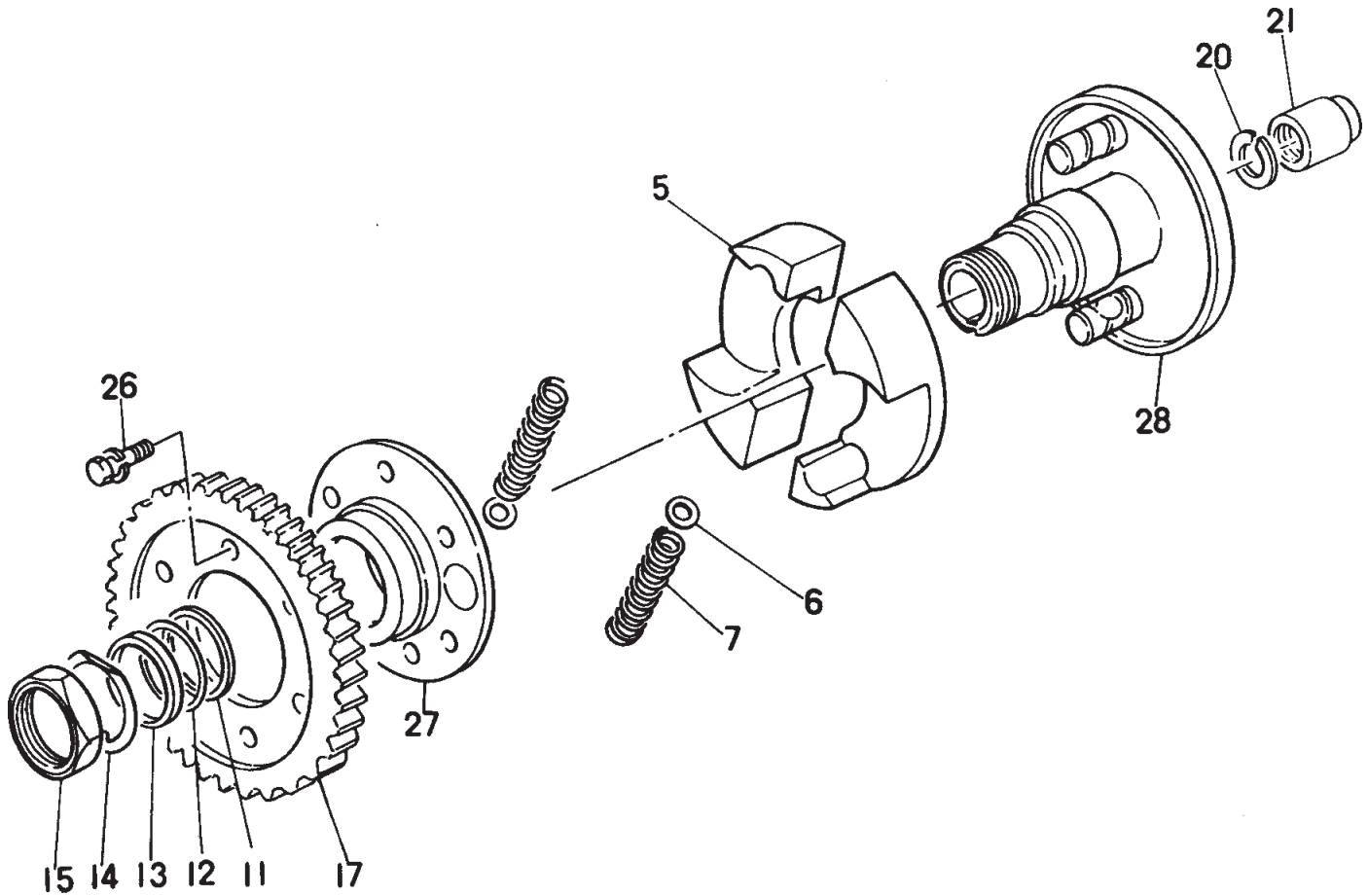

ISUZU C240 --- AUTO TIMER COMP. ASSY.

AUTO TIMER COMP. ASSY.

<u>NO.</u>	<u>PART NO.</u>	<u>ITEM</u>	<u>QTY.</u>	<u>REMARKS</u>
5	9813435050	FLYWEIGHT	2	INCL. ITEMS W/*
6*	9813450430	SHIM	A/R	
6-1*	9813450440	SHIM	A/R	
6-2*	9813450450	SHIM	A/R	
6-3*	5157490090	SHIM	A/R	
6-4*	5157490100	SHIM	A/R	
6-5*	5157490110	SHIM	A/R	
6-6*	5157490680	SHIM	A/R	
6-7*	5157490690	SHIM	A/R	
6-8*	5157490700	SHIM	A/R	
6-9*	5157490710	SHIM	A/R	
7*	9813450720	TIMER SPRING	2	
11*	9813453380	WASHER	1	
12*	9813453250	SHIM	A/R	
12-1*	9813453260	SHIM	A/R	
12-2*	9813453400	SHIM	A/R	
12-3*	9813453270	SHIM	A/R	
12-4*	9813453280	SHIM	A/R	
12-5*	9813453290	SHIM	A/R	
12-6*	9813453300	SHIM	A/R	
12-7*	9813453310	SHIM	A/R	
12-8*	9813453320	SHIM	A/R	
13*	5157490070	WASHER	1	
14*	9813450520	PLATE	1	
15*	9813453060	NUT	1	
17*	5125240660	GEAR	1	
20-1*	5156190480	LOCK WASHER	1	
21*	1156190010	NUT	1	
26*	5157490080	BOLT	6	
27*	9813433050	FLANGE	1	
28*	5157490280	HOLDER	1	

ISUZU C240 --- NOZZLE HOLDER COMP. ASSY.

NOZZLE HOLDER COMP. ASSY.

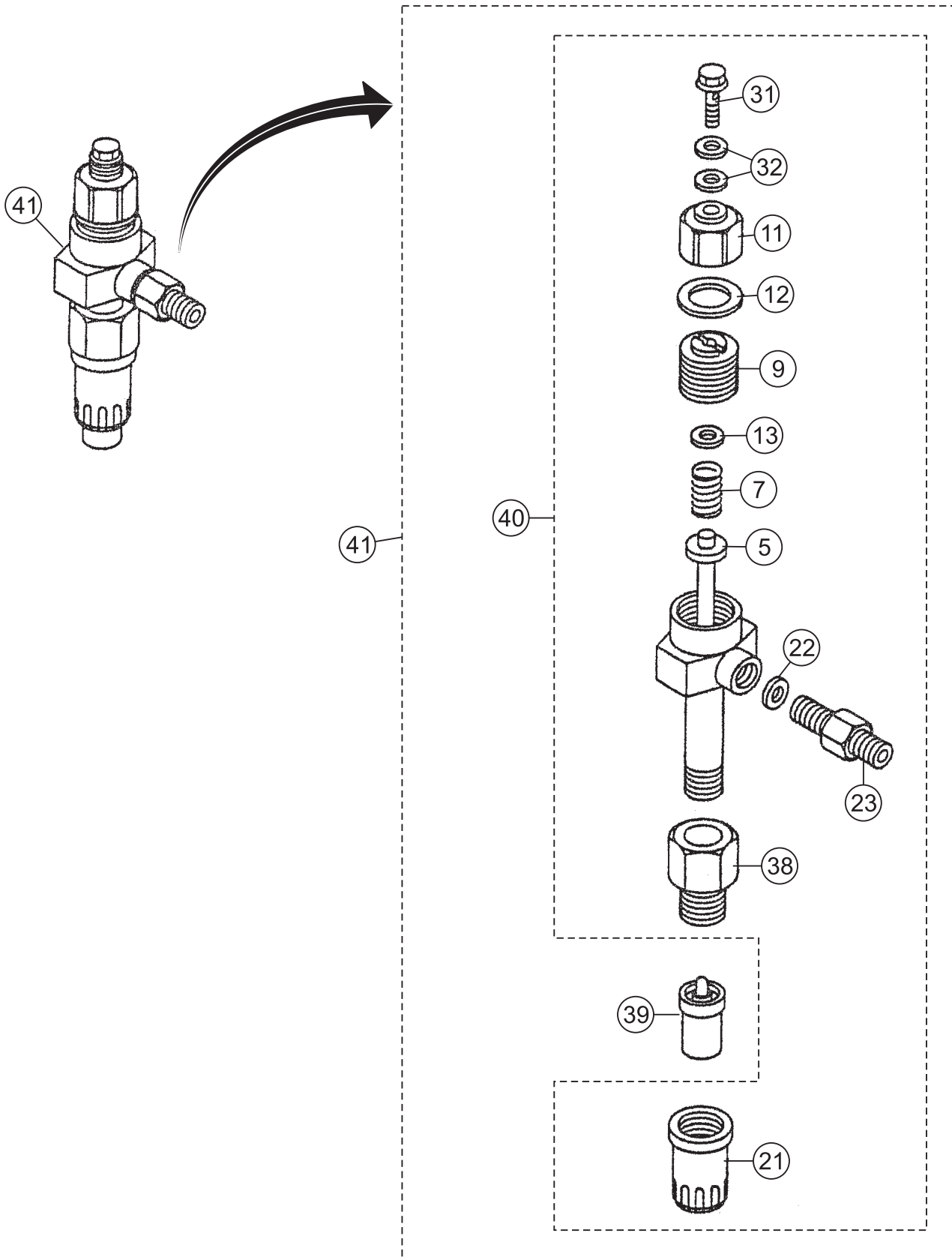

ISUZU C240 --- NOZZLE HOLDER COMP. ASSY.

NOZZLE HOLDER COMP. ASSY.

<u>NO.</u>	<u>PART NO.</u>	<u>ITEM</u>	<u>QTY.</u>	<u>REMARKS</u>
5%#	5153410020	PUSH ROD	4	
7%#	5153430020	SPRING	4	
9%#	9153396010	SCREW	4	
11%#	5153340030	NUT	4	
12%#	9153390560	GASKET	4	
13%#	9153390570	WASHER	4	
21%#	9153326030	NUT	4	
22%#	9153520050	GASKET	4	
23%#	9153510070	CONNECTOR	4	
31%#	5153490010	BOLT	4	
32%#	9095714080	GASKET	8	
38%#	9153596010	SCREW	4	
39%	5153110060	NOZZLE INJECTOR	4	
40%	8941145150	HOLDER ASSY W/O NOZZLE	4	INCLUDES ITEMS W/#
41	5153000391	NOZZLE AND HOLDER ASSY	4	INCLUDES ITEMS W/%

ISUZU C240 ---STARTER COMP. ASSY.

STARTER COMP. ASSY.

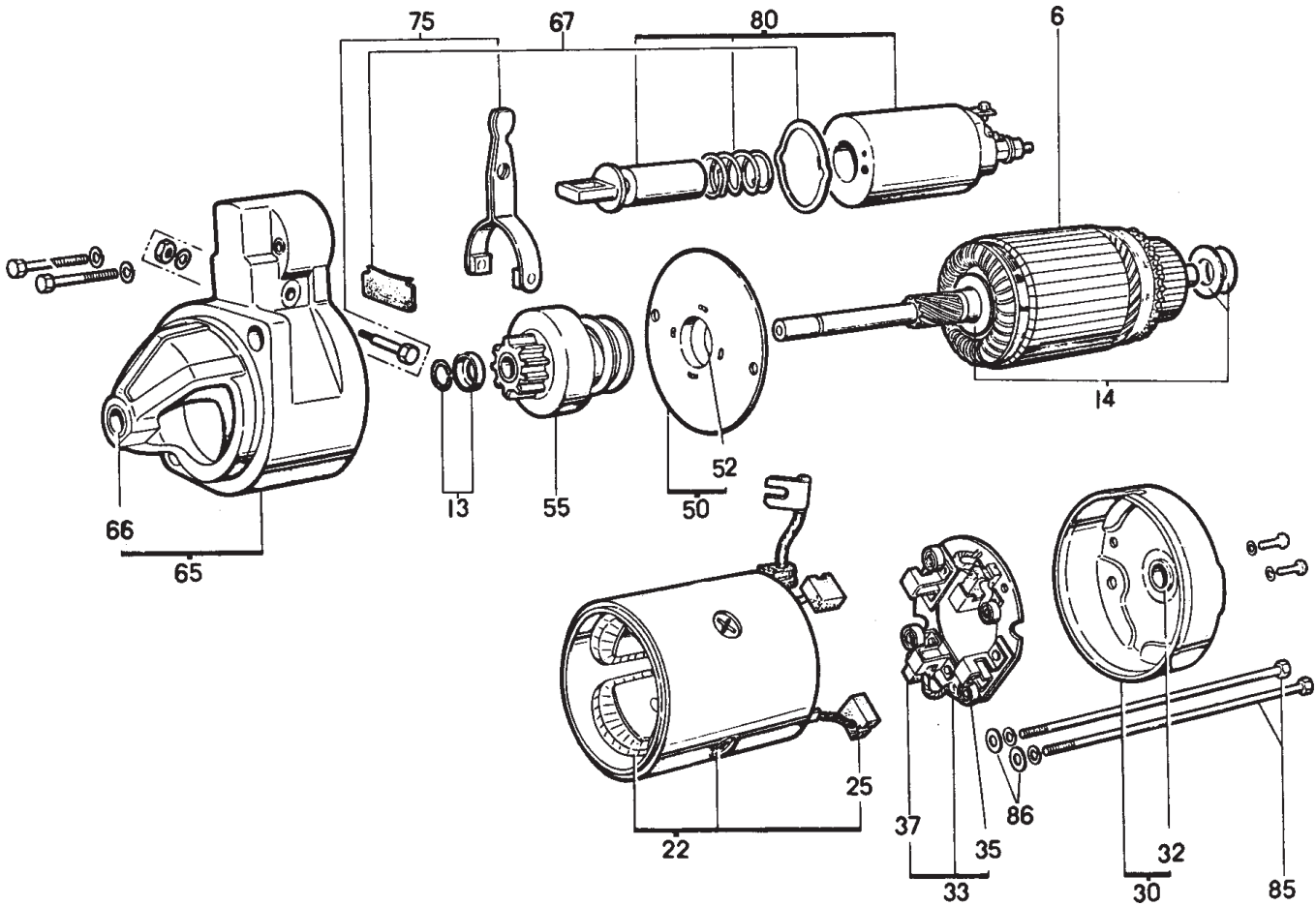

ISUZU C240 --- STARTER COMP. ASSY.

STARTER COMP. ASSY.

<u>NO.</u>	<u>PART NO.</u>	<u>ITEM</u>	<u>QTY.</u>	<u>REMARKS</u>
6	5811210160	ARMATURE ASSY.	1	INCL. ITEMS W/*
13*	5811291050	PINION STOPPER	1	
14*	5811290030	WASHER SET	1	
22*	5811120100	FIELD COIL ASSY.	1	INCL. ITEM W/>
25*>	5811160480	BRUSH, +	1	
30*	5811150130	REAR COVER ASSY.	1	INCL. ITEM W/%
32*%	5811190120	REAR METAL	1	
33*	5811160180	BRUSH HOLDER	1	INCL. ITEMS W/@
35*@	5811170060	BRUSH SPRING	4	
37*@	5811160490	BRUSH, -	2	
50*	5811190130	BRACKET ASSY.	1	INCL. ITEM W/&
52*&	9821121340	CENTER METAL	1	
55*	5811230070	CLUTCH ASSY.	1	
65*	5811130170	GEAR CASE ASSY.	1	INCL. ITEM W/#
66*#	5811190260	FRONT METAL	1	
67*	5811290680	DUST COVER	1	
75*	5811270130	SHIFT LEVER ASSY.	1	
80*	5811510290	MAGNETIC SWITCH ASSY.	1	
85*	5811290710	BOLT	2	
86*	5811290730	WASHER	2	

ISUZU C240 --- ALTERNATOR COMP. ASSY.

ALTERNATOR COMP. ASSY. (OCT. 1992~)

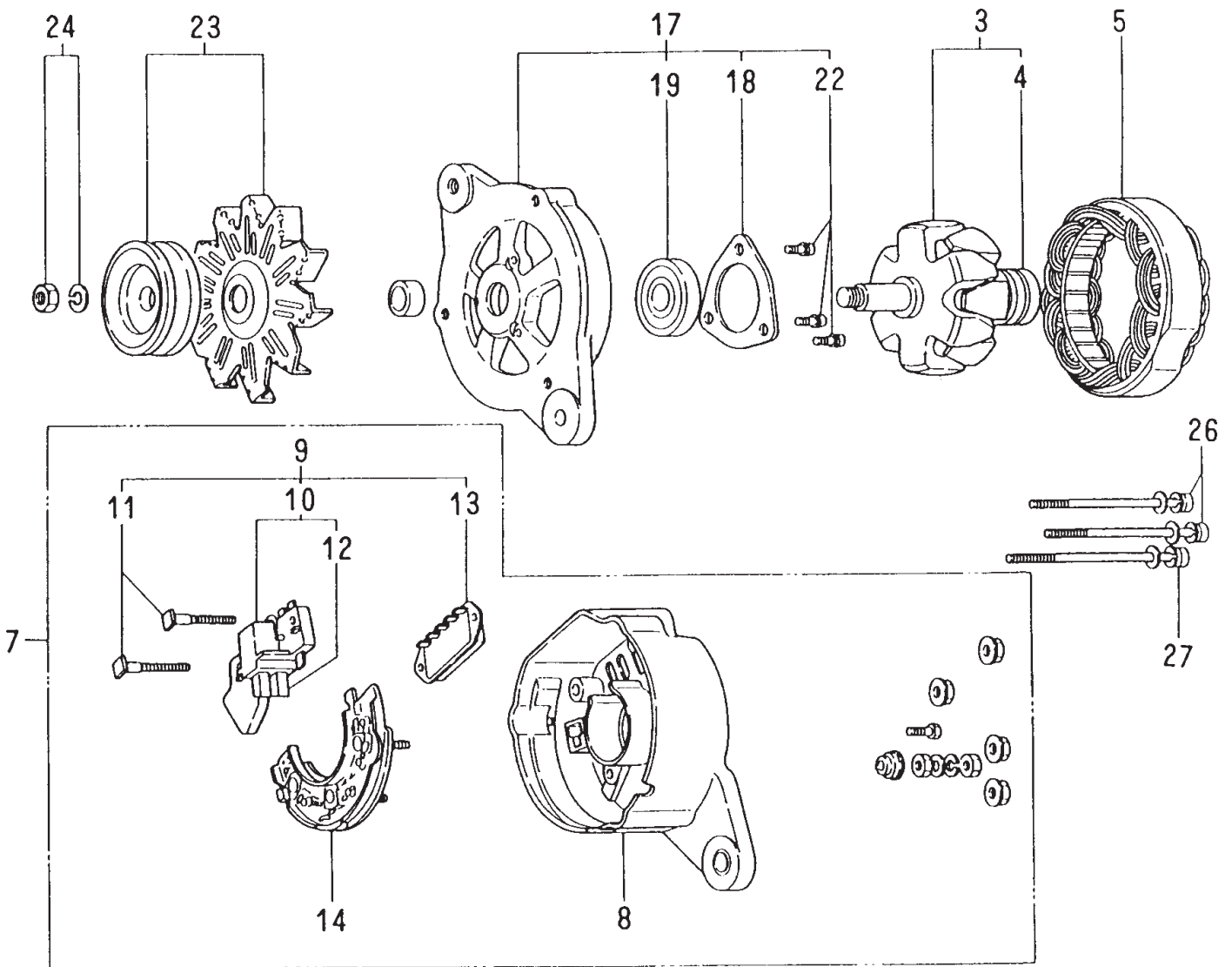

ISUZU C240 --- ALTERNATOR COMP. ASSY.

ALTERNATOR COMP. ASSY. (OCT. 1992~)

<u>NO.</u>	<u>PART NO.</u>	<u>ITEM</u>	<u>QTY.</u>	<u>REMARKS</u>
3	5812210630	ROTOR ASSY.	1	INCL. ITEMS W/* AND W/>
4*>	9000901810	BALL BEARING	1	
5*	5812110580	STRATOR ASSY.	1	
7*	5812141310	REAR COVER ASSY.	1	INCL. ITEMS W/#
8*#	5812141320	REAR COVER	1	
9*#	5812190360	BRUSH REGULATOR	1	INCL. ITEMS W/%
10*#%	5812150460	BRUSH ASSY.	1	
11*#%	5812291660	BOLT	2	
12*#%	5812150400	BRUSH	2	
13*#%	5812700040	REGULATOR ASSY.	1	
14*#	5812620050	RECTIFIER	1	
17*	5812130430	FRONT COVER ASSY.	1	INCL. ITEMS W/&
18*&	5812290290	RETAINER	1	
19*&	5098000870	BALL BEARING	1	
22*&	5812291650	SCREW KIT	1	
23*	5812220760	PULLEY ASSY.	1	
24*	9822350150	NUT	1	
26*	5812291820	BOLT	2	
27*	5812291830	BOLT	1	

ISUZU C240 ---ALTERNATOR COMP. ASSY.

ALTERNATOR COMP. ASSY. (BEFORE OCT. 1992)

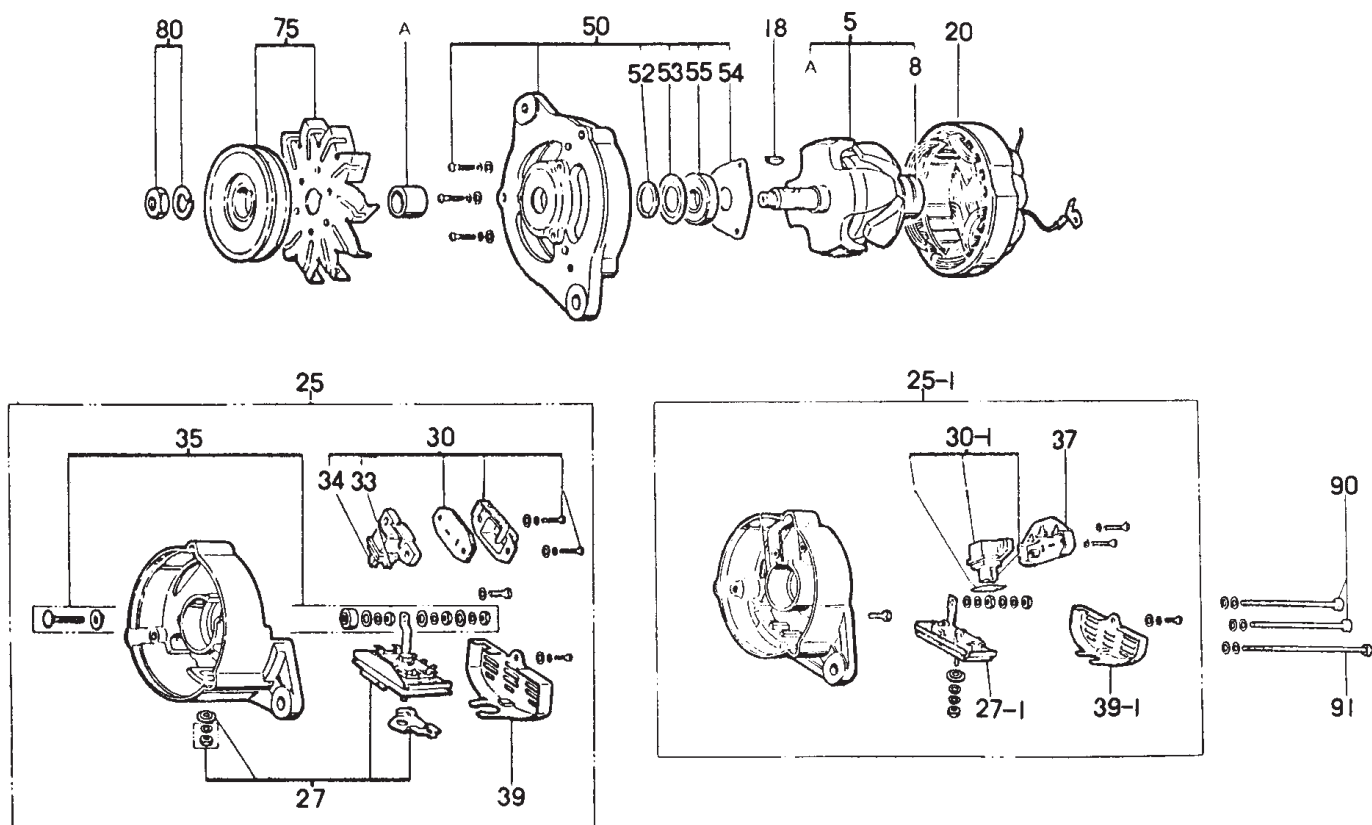

ISUZU C240 --- ALTERNATOR COMP. ASSY.

ALTERNATOR COMP. ASSY. (BEFORE OCT. 1992)

<u>NO.</u>	<u>PART NO.</u>	<u>ITEM</u>	<u>QTY.</u>	<u>REMARKS</u>
5	5812210100	ROTOR ASSY.	1	INCL. ITEMS W/*
8*	9000901810	BALL BEARING	1	
18*	9822250270	KEY	1	
20*	5812110090	STRATOR ASSY.	1	
25*	5812140010	COVER ASSY.	1	INCL. ITEMS W/#
27*#	9822316190	RECTIFIER ASSY.	1	
30*#	5812150010	HOLDER ASSY.	1	
33*#	9822316170	BRUSH	1	
34*#	9822316180	BRUSH	1	
35*#	9822350700	BOLT ASSY.	1	
39*#	9822319040	RECTIFIER COVER	1	
50*	9822313080	FRONT COVER ASSY.	1	INCL. ITEMS W/&
52*&	9822158230	PACKING	1	
53*&	9822158240	RETAINER	1	
54*&	9822159170	RETAINER BRIDGE	1	
55*&	9000901820	FRONT BALL BEARING	1	
75*	5812220140	PULLEY ASSY.	1	
80*	9822350740	NUT	1	
90*	9822350720	BOLT	2	L=85
91*	9822350730	BOLT	2	L=95

TERMS AND CONDITIONS OF SALE — PARTS

PAYMENT TERMS

Terms of payment for parts are net 30 days.

FREIGHT POLICY

All parts orders will be shipped collect or prepaid with the charges added to the invoice. All shipments are F.O.B. point of origin. Multiquip's responsibility ceases when a signed manifest has been obtained from the carrier, and any claim for shortage or damage must be settled between the consignee and the carrier.

MINIMUM ORDER

The minimum charge for orders from Multiquip is \$15.00 net. Customers will be asked for instructions regarding handling of orders not meeting this requirement.

RETURNED GOODS POLICY

Return shipments will be accepted and credit will be allowed, subject to the following provisions:

1. A Returned Material Authorization must be approved by Multiquip prior to shipment.
2. To obtain a Return Material Authorization, a list must be provided to Multiquip Parts Sales that defines item numbers, quantities, and descriptions of the items to be returned.
 - a. The parts numbers and descriptions must match the current parts price list.
 - b. The list must be typed or computer generated.
 - c. The list must state the reason(s) for the return.
 - d. The list must reference the sales order(s) or invoice(s) under which the items were originally purchased.
 - e. The list must include the name and phone number of the person requesting the RMA.
3. A copy of the Return Material Authorization must accompany the return shipment.
4. Freight is at the sender's expense. All parts must be returned freight prepaid to Multiquip's designated receiving point.

5. Parts must be in new and resalable condition, in the original Multiquip package (if any), and with Multiquip part numbers clearly marked.
6. The following items are not returnable:
 - a. Obsolete parts. (If an item is in the price book and shows as being replaced by another item, it is obsolete.)
 - b. Any parts with a limited shelf life (such as gaskets, seals, "O" rings, and other rubber parts) that were purchased more than six months prior to the return date.
 - c. Any line item with an extended dealer net price of less than \$5.00.
 - d. Special order items.
 - e. Electrical components.
 - f. Paint, chemicals, and lubricants.
 - g. Decals and paper products.
 - h. Items purchased in kits.
7. The sender will be notified of any material received that is not acceptable.
8. Such material will be held for five working days from notification, pending instructions. If a reply is not received within five days, the material will be returned to the sender at his expense.
9. Credit on returned parts will be issued at dealer net price at time of the original purchase, less a 15% restocking charge.
10. In cases where an item is accepted, for which the original purchase document can not be determined, the price will be based on the list price that was effective twelve months prior to the RMA date.
11. Credit issued will be applied to future purchases only.

PRICING AND REBATES

Prices are subject to change without prior notice. Price changes are effective on a specific date and all orders received on or after that date will be billed at the revised price. Rebates for price declines and added charges for price increases will not be made for stock on hand at the time of any price change.

Multiquip reserves the right to quote and sell direct to Government agencies, and to Original Equipment Manufacturer accounts who use our products as integral parts of their own products.

SPECIAL EXPEDITING SERVICE

A \$35.00 surcharge will be added to the invoice for special handling including bus shipments, insured parcel post or in cases where Multiquip must personally deliver the parts to the carrier.

LIMITATIONS OF SELLER'S LIABILITY

Multiquip shall not be liable hereunder for damages in excess of the purchase price of the item with respect to which damages are claimed, and in no event shall Multiquip be liable for loss of profit or good will or for any other special, consequential or incidental damages.

LIMITATION OF WARRANTIES

No warranties, express or implied, are made in connection with the sale of parts or trade accessories nor as to any engine not manufactured by Multiquip. Such warranties made in connection with the sale of new, complete units are made exclusively by a statement of warranty packaged with such units, and Multiquip neither assumes nor authorizes any person to assume for it any other obligation or liability whatever in connection with the sale of its products. Apart from such written statement of warranty, there are no warranties, express, implied or statutory, which extend beyond the description of the products on the face hereof.

Effective: February 22, 2006

OPERATION AND PARTS MANUAL

HERE'S HOW TO GET HELP

PLEASE HAVE THE MODEL AND SERIAL
NUMBER ON-HAND WHEN CALLING

UNITED STATES

Multiquip Corporate Office

18910 Wilmington Ave.
Carson, CA 90746
Contact: mq@multiquip.com

Tel: (800) 421-1244
Fax (800) 537-3927

Service Department

800-421-1244
310-537-3700

Fax: 310-537-4259

Technical Assistance

800-478-1244

Fax: 310-943-2238

MQ Parts Department

800-427-1244
310-537-3700

Fax: 800-672-7877
Fax: 310-637-3284

Warranty Department

800-421-1244
310-537-3700

Fax: 310-943-2249

MEXICO

MQ Cipsa

Carr. Fed. Mexico-Puebla KM 126.5
Momoxpan, Cholula, Puebla 72760 Mexico
Contact: pmastretta@cipsa.com.mx

Tel: (52) 222-225-9900
Fax: (52) 222-285-0420

CANADA

Multiquip

4110 Industriel Boul.
Laval, Quebec, Canada H7L 6V3
Contact: jmartin@multiquip.com

Tel: (450) 625-2244
Tel: (877) 963-4411
Fax: (450) 625-8664

UNITED KINGDOM

Multiquip (UK) Limited Head Office

Unit 2, Northpoint Industrial Estate,
Globe Lane,
Dukinfield, Cheshire SK16 4UJ
Contact: sales@multiquip.co.uk

Tel: 0161 339 2223
Fax: 0161 339 3226

© COPYRIGHT 2012, MULTIQUIP INC.

Multiquip Inc, the MQ logo and the MQ Power logo are registered trademarks of Multiquip Inc. and may not be used, reproduced, or altered without written permission. All other trademarks are the property of their respective owners and used with permission.

This manual MUST accompany the equipment at all times. This manual is considered a permanent part of the equipment and should remain with the unit if resold.

The information and specifications included in this publication were in effect at the time of approval for printing. Illustrations, descriptions, references and technical data contained in this manual are for guidance only and may not be considered as binding. Multiquip Inc. reserves the right to discontinue or change specifications, design or the information published in this publication at any time without notice and without incurring any obligations.

Your Local Dealer is:

