



PREMIUM AUTOMATIC BLOOD PRESSURE MONITOR



INSTRUCTION
MANUAL



Parts and Components

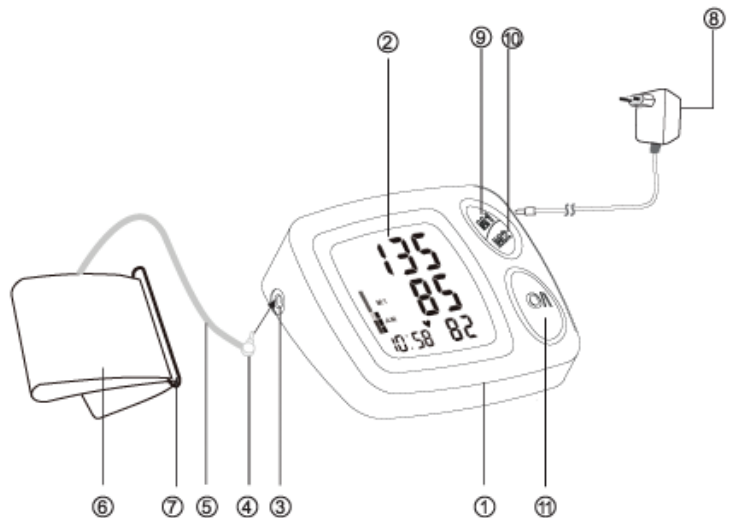

1. Main Body
2. Display
3. Cuff Connection
4. Tube Plug
5. Air Hose
6. Cuff

7. D-ring
8. AC Power Adapter
9. Button 'M1'
10. Button 'M2'
11. Button 'O/I'
12. Batteries (Optional)

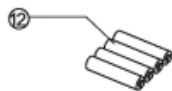

Premium Automatic Blood Pressure Monitor

Instruction Manual - RX805

Table of Contents

1. General

Principle of Operation

2. Tips On Taking Blood Pressure Measurement

2.1 About Blood Pressure

2.2 Normal Blood Pressure Values

2.3 Obtaining Accurate Measurements

2.4 Before Measuring

2.5 Common Sources of Error

2.6 Fitting the Cuff

3. Battery Installation

4. Use the Device With AC Power Adapter

5. Setting the Date and Time

6. Carry Out a Measurement

Automatic Inflation

Rapid Deflation During Measurement

7. Function of Memory

Memory Recall

Memory Clearance

8. WHO Blood Pressure Classification Indication

9. Irregular Heartbeat Detector

10. Error and Low Battery Information

11. Care, Storing, Repair and Recycling

12. Troubleshooting

13. Warranty

14. Technical Specifications

1. General

This instruction manual is intended to assist the user in the safe and efficient operation of the Be Better™ Premium Automatic Blood Pressure Monitor model RX805. The device should be used in accordance with the procedures described in this manual. It is important to read and understand the entire manual, especially section 2 “Tips on Taking Blood Pressure Measurement.”

This device is intended for the non-invasive measurement of systolic and diastolic arterial blood pressure and pulse rate in adults age 15 and above.

Principle Of Operation

This device uses oscillometric technology to measure the arterial blood pressure and pulse rate. The cuff is wrapped around the arm and automatically inflated by the air pump. The sensor in the device senses weak fluctuation of the pressure in the cuff produced by extension and contraction of the artery of the arm in response to each heartbeat. The amplitude of the pressure waves is measured, converted in millimeters of the mercury column, and is displayed on the display.

This device can not provide reasonable accuracy if used or stored in the temperature or humidity beyond the range stated in the section “TECHNICAL SPECIFICATIONS” of this manual.

2. Tips On Taking Blood Pressure Measurement

2.1 About Blood Pressure

Blood pressure level is determined in the circulatory center of your brain. Your nervous system allows the body to adapt or alter blood pressure in response to different situations. Your body alters your pulse or heart rate and the width of blood vessels through changes in muscles in the walls of blood vessels.

Your blood pressure reading is highest when your heart pumps or ejects blood. This stage is called your systolic blood pressure.

Your blood pressure is lowest when the heart rests (in-between beats). This is called your diastolic blood pressure.

It is critical to maintain blood pressure values within a “normal” range in order to prevent cardiovascular diseases. Increased blood pressure values (various forms of hypertension) have associated long and medium term health risks. These risks concern the arterial blood vessels of your body, which are endangered due to constriction caused by deposits in the vessel walls (arteriosclerosis). An insufficient supply of blood to important organs (heart, brain, muscles) can be the result. Furthermore, with long-term increased blood pressure values, the heart will become structurally damaged.

There are many different causes of the appearance of high blood pressure. We differentiate between common primary (essential) hypertension, and secondary hypertension. The latter group can be ascribed to specific organic malfunctions. Please consult your doctor for information about the possible origins of your own increased blood pressure values.

2.2 Normal Blood Pressure Values

Blood pressure is generally considered too high when, at rest, the diastolic pressure is above 90 mmHg or the systolic blood pressure is over 140 mmHg.

If you obtain readings in this range, consult your doctor immediately. High blood pressure values over time can damage blood vessels, vital organs such as the kidney, and your heart.

Should the systolic blood pressure values lie between 140 mmHg and 160 mmHg or the diastolic blood pressure values lie between 90 mmHg and 95 mmHg, consult your doctor. Regular self-checks will be necessary.

With blood pressure values that are too low (i.e., systolic values under 105 mmHg or diastolic values under 60 mmHg), consult with your doctor.

Even with normal blood pressure values, a regular self-check with your blood pressure monitor is recommended. In this way you can detect possible changes in your values early and react appropriately.

Refer to the following table for classifying blood pressure values (units: mmHg) according to the World Health Organization (WHO):

Category	Systolic Blood Pressure	Diastolic Blood Pressure
Optimal	< 120	< 80
Normal	< 130	< 85
High Normal	130 - 139	85 - 89
Hypertension		
• Stage 1: Mild	140 - 159	90 - 99
• Stage 2: Moderate	160 - 179	100 - 109
• Stage 3: Severe	≥ 180	≥ 110
Isolated Systolic Hypertension	> 140	< 90

2.3 Obtaining Accurate Measurements

Your blood pressure can vary based on numerous factors, physiological conditions, and your surroundings. Follow these guidelines to obtain accurate and error-free measurements of your blood pressure and pulse rate.

2.4 Before Measuring

- Avoid eating, smoking as well as all forms of exertion directly before the measurement. All these factors influence the measurement result. Relax by sitting in an armchair in a quiet atmosphere for about 5 minutes before the measurement.
- Always take measurements on the same arm (normally left) and in the same posture. Do not switch between right and left arms while recording your blood pressure as there may be a difference of up to 10 mmHg pressure between the two arms.
- Attempt to carry out the measurements regularly at the same time of day, since blood pressure changes during the course of the day. The ideal time to measure your blood pressure is in the morning after you wake up, before breakfast and physical activity, and in the absence of the urge to urinate.
- Rest for 5 minutes sitting quietly and release all the tension in your body — especially the arm muscles — before beginning with the measurement. Remain calm and quiet when the measurement is in process. Do not speak or move your arm (as well as other body) muscles during the process.

2.5 Common Sources of Error

Any efforts by the patient to support the arm can increase the blood pressure. Make sure you are in a comfortable, relaxed position and do not activate any of the muscles in the measurement arm during the measurement. Use a cushion for support if necessary and rest your arm completely.

ATTENTION!

Comparable blood pressure measurements always require the same conditions with a peaceful and calm environment. Ensure that you take measurements under the same conditions to obtain an accurate estimate of blood pressure variation patterns.

- The cuff should be at heart level.
- If the arm artery lies considerably lower or higher than the heart, an erroneous value of blood pressure is measured. Each 15 cm difference in height results in a measurement error of 10 mmHg.
- A loose cuff causes false measurement values.
- With repeated measurements, blood accumulates in the arm, which can lead to false results. Consecutive blood pressure measurements should be repeated after at least a 15 second pause or after the arm has been held up in order to allow the accumulated blood to flow away.

2.6 Fitting the Cuff

a) Put the end of the cuff (with fastener) through the metal ring, making the cuff a cylinder. (Ignore this step if your cuff is already set up.) Proper assembly allows the Velcro® to match up properly.



b) Place the cuff around your arm. Make sure the bottom edge of the cuff is about 1" above the elbow joint. Adjust the cuff so that the rubber tubing under the cuff lies over the brachial

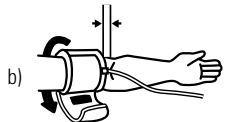

artery, which runs on the inside of the arm (see Fig. C).

c) Pull the cuff and tighten it by attaching the Velcro® fastener. Normally, the left arm is used, unless there is a physical reason for using the right arm.

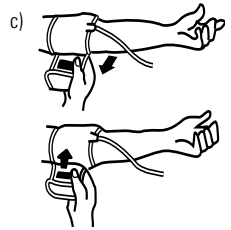

d) The cuff should fit snugly around the arm, but not too tight. You should be able to fit two fingers under the cuff.

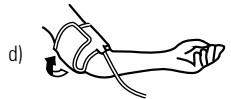

e) Place the arm on the table (palm facing upwards) so that the cuff is at the same level as the heart. Make sure there is no kink in the hose.



f) You can adjust the level of your arm by putting a cushion under your arm.

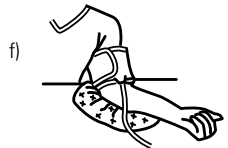

g) Remain seated in a comfortable room temperature for at least 5 minutes, then start the measurement.



h) For those who cannot put the cuff on the left arm, put it on the right arm as shown.

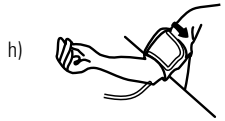

i) Consecutive measurements will cause blood accumulation in the lower arm which will affect the measuring results. To improve reading accuracy, raise the arm being measured, squeeze and relax your hand several times, then take another measurement. Another option is to take the cuff off and wait at least 10 minutes before repeating measurement.



j) If this device was stored in low temperature, it is necessary to leave it in room temperature for at least 1 hour, otherwise the measurement can be inaccurate.

ATTENTION: Do not use cuff other than the original cuff contained in this kit!

3. Battery Installation

1. Open the battery cover and install four 'AA' type batteries into the battery compartment as indicated. Make sure that the polarity is correct.
 2. Close the battery compartment cover.
- Replace the batteries when the replacement indication "☐" appears in the display or nothing after **0/I** button is pressed.
 - Use AA alkaline batteries, do not use rechargeable batteries.

- Use only the same type of batteries together. Replace all batteries simultaneously; if the device isn't being used for a long time, please take out the batteries.
- Don't leave the worn batteries in the device.

4. Using the Device With AC Power Adapter

Besides batteries you can use the AC power adapter as the power supply.

- Insert the AC adapter cord into the jack on the right side of the monitor.
- Insert the AC adapter plug into the outlet.
- To remove the AC adapter, disconnect the adapter plug from the AC outlet first and then disconnect the cord from the monitor's jack.

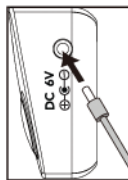

Caution

- To avoid possible damage to the monitor, use only the AC adapter included. Other adapters may damage the blood pressure monitor.

Note: The monitor is designed not to draw power from the batteries when the AC adapter is in use.

AC adapter technical feature:

Output voltage: $6V \pm 5\%$

Max. output current: At least 600 mA

Output plug polarity: <-> inner

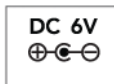

5. Setting the Date and Time

The function provides accurate measuring time for each measurement. To get accurate date and time, the user should preset the date and time correctly before the first use of this device. The operation procedure for presetting Date/Time is as follows:

1. When the device is connected to power on for the first time, the display will show as Fig. 1.
2. Press and hold button **'M1'**, then press button **'0/I'**, and the year number flashes.
3. Press button **'M1'** or **'M2'** to subtract or add the number, and press button **'0/I'** for confirmation.
4. When the year setup is finished, the month number will flash automatically. Please follow the same instruction as above to set month, date and time.
5. Press button **'0/I'** to finish setup. If you want to change the date and time, please repeat procedure 2, 3, 4.



Fig. 1



Fig. 2



Fig. 3

Note: When in the Date/Time setting, if no button is pressed in 1 minute, the device will automatically return to standby mode.

6. Measuring Your Blood Pressure

1. Insert the tube plug into the air connector. Before the measurement, take 3~5 times deep breaths and relax yourself. Don't talk or move your arm.

2. Press button '**O/I**', and all symbols will appear on display for 2 seconds as Fig.4. Then two short beeps will sound and '0' will appear on the screen. Pump begins to inflate with display showing the reading of pressure. Generally the pressure will reach 190 mmHg as Fig.5.



Fig.4



Fig.5



Fig.6

3. The pump will stop inflating and pressure begins to decrease gradually, during which the user's blood pressure and pulse will be calculated as Fig.6.
4. There will be a long beep following the accomplishment of measurement. The air in the cuff will deflate quickly and the blood pressure reading and pulse reading will show in the display. Moreover the measuring time will also display together in two screens alternately. At the same time, the 'M1' or 'M2' will flash to remind the user to record the reading as Fig.7.



Fig.7



Fig.8



5. Press button '**M1**' or button '**M2**' to record the reading in corresponding memory. For example, if button '**M2**' is pressed, the display will show as Fig.8. If the user does not press button '**M1**' or '**M2**' or press button '**O/I**', the reading won't be recorded.
6. Press the button '**O/I**' to return to the standby mode. Please rest for at least 3 minutes for another measurement. If the device isn't used for 3 minutes, the device will return to standby mode automatically.

Automatic Inflation

There are 4 given levels of given inflation pressure for this device: 190mmHg, 230mmHg, 270mmHg and 300mmHg. When 190mmHg is not enough or movement of arm occurs, the device will automatically inflate to a reasonable pressure level to ensure a successful measurement. It is not a fault.

Rapid Deflation During Measurement

If you do not feel well during measurement or want to stop the measurement for some reason, you can press the **O/I** button. The device will quickly release the air in cuff and the device will be returned to standby mode.

Repeated measurements with intervals of 3 minutes are recommended, so you can calculate the average to get more accurate measurement. Atherosclerosis patients are required longer intervals (10-15 minutes) as elasticity of patients' vessels decreased significantly in these diseases. 10-15 minute intervals is also applicable for patients suffering from diabetes for a long time.

7. Function of Memory

Memory Recall

1. RX805 can store 60 sets of readings each in 'M1' and 'M2', and will automatically calculate the average value of the latest 3 readings for 'M1' and 'M2' respectively. When the memory is full (60 sets of readings are stored), the oldest reading will be replaced by a new one. Memory will not clear away even if power supply is removed.
2. After a measurement is finished or when the device is in standby mode, the user can press button '**M1**' or button '**M2**' to recall memory. Press button '**M1**', the display will show the average value of the last 3 readings taken as Fig.9.



3. Press again, the display will show '01', which means the last reading taken, then turns to another screen to show readings and measuring time as Fig.10;
4. Press again, the display will show '02', which means the second to the last reading taken.

Memory Clearance

After a measurement is finished or when the device is in standby mode, press and hold button 'M1' or 'M2' for at least 5 seconds, the display will show 'Clr' which means the stored readings for 'M1' or 'M2' have been removed. Fig. 11.

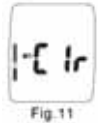

8. Blood Pressure Assessment Software

Standards for assessment of high or low blood pressure, regardless of age, have been established by World Health Organization (WHO) as shown in the chart to the right:

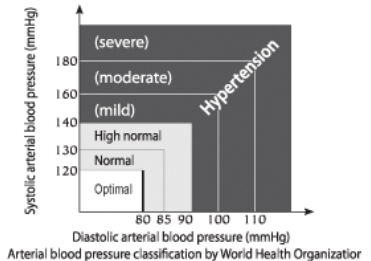

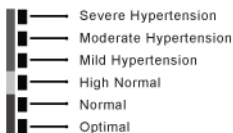

The indicator displays a segment, based on the current data, corresponding to the WHO classification. For example, if your blood pressure is 135 mmHg (Systolic Pressure), 78 mmHg (Diastolic Pressure), according to the world health organization standard, your blood pressure level is High Normal.



Note:

1. If the systolic blood pressure and diastolic blood pressure fall into different categories, the higher value should be taken for classification.
2. The WHO blood pressure classification indication in the device is only a reminder, it can not be regarded as the final diagnosis.

9. Irregular Heartbeat Detector

Model RX805 blood pressure monitor provides a blood pressure and pulse rate measurement even when an irregular heartbeat occurs. When the device detects an irregular heartbeat, or any excessive body movement during the measurement, the  icon will appear and flash. It is important that you be relaxed, remain still and do not talk during measurement. If the  symbol appears frequently (e.g. several times a week), it may be an indication of a more serious heart problem, and you should consult your doctor.

10. Error and Low Battery Information

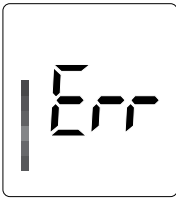
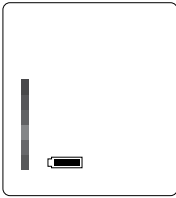
INDICATION	POSSIBLE REASON	CORRECT METHOD
	<p>The cuff is put on im- properly or the tube plug is inserted too loosely.</p> <p>Movement of arm/ hand or talking during measurement.</p> <p>The cuff is not inflated to necessary pressure.</p>	<p>Make sure that cuff is put on correctly and the tube plug is inserted tightly and repeat the measurement.</p> <p>Repeat the measure- ment with no movement and follow recommen- dations of manual.</p> <p>Repeat the measure- ment with pumping cuff to higher pressure.</p>
	<p>The batteries are weak.</p>	<p>Replace all 4 batteries with new ones.</p>

11. Care, Storing, Repair and Recycling

1. It's necessary to protect this device against high moisture, direct sunlight, shock, solvent, alcohol and gasoline.
2. Remove the batteries if the device is to be stored for a long time, and keep the batteries away from children.

3. Keep the cuff from sharp objects and don't extend or twist the cuff.

4. Use only soft and dry cloths to clean the device.

WARNING: Under no circumstances may you wash the inner bladder!

6. Since neither the device nor batteries are household waste, follow your local recycling rules and dispose them at appropriate collection sites.

7. Do not open the device. It has delicate electrical components and an intricate air unit that could be damaged. If you cannot fix the problem using the troubleshooting instruction, request service from your dealer.

8. It is generally recommended to have the monitor inspected every 2 years, to ensure proper functioning and accuracy and safety. Please contact your dealer for maintenance.

WARNING: Do not modify the equipment without authorization of the manufacturer.

12. Troubleshooting

SYMPTOM	CHECK POINT	REMEDY
No display when the device is turned on.	The batteries have run down.	Replace all batteries with new ones.
	The polarity of battery is wrong.	Install batteries correctly.
	Proper battery contact is not being made.	Clean the battery terminals with dry cloth.

<p>Inflation stops and re-inflates later.</p>	<p>The automatic inflation for ensuring correct measurement.</p> <p>Did you talk or move your arm (or hand) during measurement?</p>	<p>See “Automatic Inflation”</p> <p>Remain still and silent during the measurement.</p>
<p>The reading is extremely high or low.</p>	<p>Is the cuff at the same level as the heart?</p> <p>Is the cuff wrapped right?</p> <p>Did you strain your arm during measurement?</p> <p>Did you talk or move your arm during measurement?</p>	<p>Make sure that your posture is right.</p> <p>Wrap the cuff correctly.</p> <p>Relax during measurement.</p> <p>Remain still and silent during the measurement.</p>
<p>Pulse rate is too low or too high.</p>	<p>Did you talk or move your arm during measurement?</p> <p>Did you take measurement right after exercise?</p>	<p>Remain still and silent during the measurement.</p> <p>Take measurement again after resting for more than 5 minutes.</p>
<p>The batteries run down soon.</p>	<p>Faulty batteries are used.</p>	<p>Use alkaline batteries of known manufacturers.</p>

13. Lifetime Guarantee

Be Better™ blood pressure monitors have a lifetime warranty to be free of manufacturing defects for the life of the original owner. This warranty does not include the inflation system including the cuff and inflation bladder. The cuff is warranted for two years. The warranty does not cover damage from misuse or tampering.

If you have questions regarding the operation of your monitor call the **Blood Pressure Hotline:**

1-866-536-2289

Should repair be necessary, return the unit with all component pieces. Enclose proof of purchase and \$5.00 for return shipping and insurance. Ship the unit **prepaid** and insured (at owners option) to:

Thermor Ltd.
Repair Department
16975 Leslie Street
Newmarket, ON L3Y 9A1

thermor@thermor-ins.com

Please include your name, return address, phone number, and email address. Thermor will repair or replace (at Thermor's option) free of charge any parts necessary to correct the defect in material or workmanship.

Please allow 10 days for repair and return shipping.

14. Technical Specifications

Model:	RX805
Size:	127(L) x 99(W) x 50(H)mm
Weight:	Approximately 255g without batteries
Measuring method:	Oscillometry
Measuring range:	40 to 260 mmHg (blood pressure) 40 to 160 beats/minute (pulse rate)
Measuring accuracy:	±3 mmHg for static pressure 5% of the reading for the pulse rate
Inflation:	Automatic by the pump
Rapid deflation:	Automatic electronic valve
Batteries:	4 x "AA", 1.5V
Adaptor:	6V, 600mA
Memory :	2 x 60 sets of memories
Operation temperature and humidity:	+10°C to +40°C, 85% and below
Storage temperature and humidity:	-20°C to +50°C, 85% and below
Upper arm circumference:	Applicable for arm circumference 23-36cm / 9-14.25in (standard cuff); 32-43cm/12.5-16.9in (large adult cuff)
Complete Kit:	Main body, standard cuff, large adult cuff (optional), 4 x AA batteries (optional), adapter, instruction manual.

