

MODELS D2CE & D2CG300
(8.5 EER)

035-16133

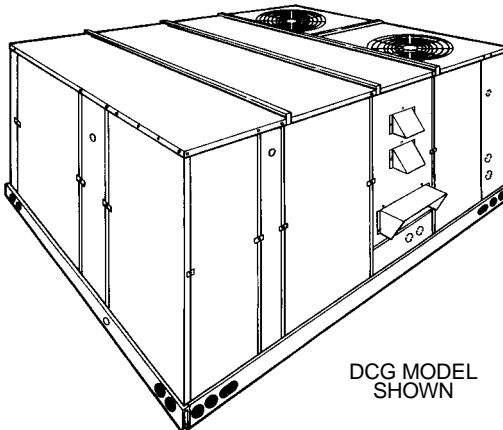

SAFETY CONSIDERATIONS

Due to system pressure, moving parts and electrical components, installation and servicing of air conditioning equipment can be hazardous. Only qualified, trained, service personnel should install, repair, maintain or service this equipment.

YORK Model DCE and DCG units are single package air conditioners designed for outdoor installation on a rooftop or a slab and is manufactured under ISO 9002 Quality System Certification. The DCE models are cooling only and can be equipped with factory installed electric heaters for cooling / heating applications. The DCG models are gas-fired central heating furnaces with cooling.

The units are completely assembled on rigid, permanently attached base rails. All piping, refrigerant charge, and electrical wiring is factory installed and tested. All units require electric power, duct connections and fixed outdoor air intake damper (units without economizer or motorized damper option only) at the point of installation.

The DCG units additionally require gas connection, installation of the combustion air inlet hood and the flue gas outlet hoods at the point of installation. The gas-fired heaters have aluminized-steel tubular heat exchangers and spark ignition with proven pilot.

Supplemental electric heaters for DCE units have nickel-chrome elements and utilize single point power connections.

The following safety precautions apply to DCG units:

INSPECTION

As soon as a unit is received, it should be inspected for possible damage during transit. If damage is evident, the extent of the damage should be noted on the carrier's freight bill. A separate request for inspection by the carrier's agent should be made in writing. Refer to Form 50.15-NM for additional information.

REFERENCE

Additional information on the design, installation, operation and service of this equipment is available in the following reference forms:

- 44-320-10 - Barometric Relief Damper Accessory
- 530.18-N6.1V - Propane Conversion Accessory
- 530.18-N6.2V - High Altitude Accessory (Nat. Gas)
- 530.18-N6.3V - High Altitude Accessory (Propane)
- 530.18-n13y - Coil Guard Installation

Renewal Parts:

- Refer to the Renewal Parts Manual for complete listing of replacement parts on this equipment.

All forms referenced in this instruction may be ordered from:

Publications Distribution Center
Unitary Products Group
P.O. Box 1592, York, Pa. 17405

APPROVALS

Design certified by ETL & CGA as follows:

1. For use as a central cooling only unit with or without supplemental electric heat. (DCE models)
2. For use as a forced air furnace with cooling unit. (DCG models)
3. For use with natural gas or propane gas. (DCG models)
4. For outdoor installation only.
5. For installation on combustible material.

FOR YOUR SAFETY

If you smell gas:

1. **Open windows.**
2. **Don't touch electrical switches; do not use any phones in the area of the gas leak.**
3. **Extinguish any open flame.**
4. **Immediately call your gas supplier from another location. Follow your gas supplier's instructions.**
5. **If you cannot reach your gas supplier, call the fire department.**

FOR YOUR SAFETY

Do not store or use gasoline or other flammable vapors and liquids in the vicinity of this or any other appliance.

CAUTION

THIS PRODUCT MUST BE INSTALLED IN STRICT COMPLIANCE WITH THE ENCLOSED INSTALLATION INSTRUCTIONS AND ANY APPLICABLE LOCAL, STATE, AND NATIONAL CODES INCLUDING, BUT NOT LIMITED TO, BUILDING, ELECTRICAL, AND MECHANICAL CODES.

WARNING

INCORRECT INSTALLATION MAY CREATE A CONDITION WHERE THE OPERATION OF THE PRODUCT COULD CAUSE PERSONAL INJURY OR PROPERTY DAMAGE

Installer should pay particular attention to the words: *NOTE*, *CAUTION* and *WARNING*. Notes are intended to clarify or make the installation easier. Cautions are given to prevent equipment damage. Warnings are given to alert installer that personal injury and/or equipment damage may result if installation procedure is not handled properly.

TABLE OF CONTENTS

General 1
 Inspection..... 1
 Reference..... 1
 Approvals 1
 Nomenclature..... 2

INSTALLATION

Limitations 3
 Location 3
 Rigging and Handling 3
 Clearances..... 3
 Ductwork 3
 Fixed Outdoor Air Intake Damper 4
 Condensate Drain..... 4
 Compressors..... 4
 Filters 4
 Service Access 4
 Thermostat..... 5
 Power and Control Wiring 5
 Optional Electric Heaters (DCE Models) 5
 Combustion Discharge (DCG Models) 5
 Gas Piping (DCG Models) 6
 Gas Connection (DCG Models)..... 6
 L.P. Units, Tanks and Piping (DCG Models) 6
 Vent and Combustion Air Hoods (DCG Models) 7
 Econ. / Mot. Damper Rain Hood Accy. (1EH0401) 7
 Econ. / Power Rain Hood Accy. (1EH0402) 9

OPERATION

Cooling System 15
 Preliminary Operation Cooling..... 15
 Cooling Sequence of Operation..... 15
 Safety Controls (Cooling)..... 15
 Electric Heating - Sequence of Operation 15
 Heating Anticipator Setpoints 16
 Gas Heating - Sequence of Operation 16
 Safety Controls (Heating)..... 16
 Heat Anticipator Setpoints 17
 Pre-Start Check List..... 17

START-UP

Operating Instructions..... 17
 Post-Start Check List 17
 Manifold Gas Pressure Adjustment 17
 Pilot Checkout..... 18
 Burner Instructions..... 18
 Burner Air Shutter Adjustment..... 18
 Checking Supply Air CFM..... 18
 Adjustment of Temperature Rise..... 19
 Checking Gas Input 19
 Secure Owner's Approval 19

MAINTENANCE & TROUBLESHOOTING

Normal Maintenance 20
 Cleaning Flue Passages and Heating Elements 20
 Troubleshooting..... 21
 Replacement Parts 23

TABLES

| No. | Description | Page |
|-----|---|------|
| 1 | Unit Application Data | 3 |
| 2 | Gas Heat Application Data | 6 |
| 3 | Pipe Sizing | 6 |
| 4 | Physical Data | 10 |
| 5 | Electrical Data - Basic Units | 10 |
| 6 | Electrical Data - Units With Elec. Heat | 10 |
| 7 | Four and Six Point Loads | 13 |
| 8 | Supply Air Blower Performance | 13 |
| 9 | Static Resistances | 14 |
| 10 | Power Exhaust Performance | 14 |
| 11 | Blower Motor and Drive Data | 14 |
| 12 | Heat Anticipator Setpoint | 16 |
| 13 | Limit Control Setting | 17 |
| 14 | Gas Rate - Cubic Feet Per Hour | 19 |

FIGURES

| No. | Description | Page |
|-----|-------------------------------------|------|
| 1 | Typical Rigging | 3 |
| 2 | Center of Gravity | 3 |
| 3 | Fixed Outdoor Air Damper | 4 |
| 4 | Recommended Drain Piping | 4 |
| 5 | Typical Field Wiring | 5 |
| 6 | External Supply Connection | 6 |
| 7 | Bottom Supply Connection | 7 |
| 8 | Vent and Combustion Air Hoods | 8 |
| 9 | Adjusting Enthalpy Setpoint | 9 |
| 10 | Dimensions and Clearances | 11 |
| 11 | Dimensions and Clearances (cont'd) | 12 |
| 12 | Four and Six Point Loads | 13 |
| 13 | Gas Valve Piping | 16 |
| 14 | Gas Valve and Controls | 17 |
| 15 | Typical Gas Valve | 17 |
| 16 | Proper Flame Adjustment | 18 |
| 17 | Typical Flame Appearance | 18 |
| 18 | Belt Adjustment | 18 |
| 19 | Pressure Drop versus Supply Air CFM | 19 |
| 19 | Typical Flue Baffle Installation | 20 |

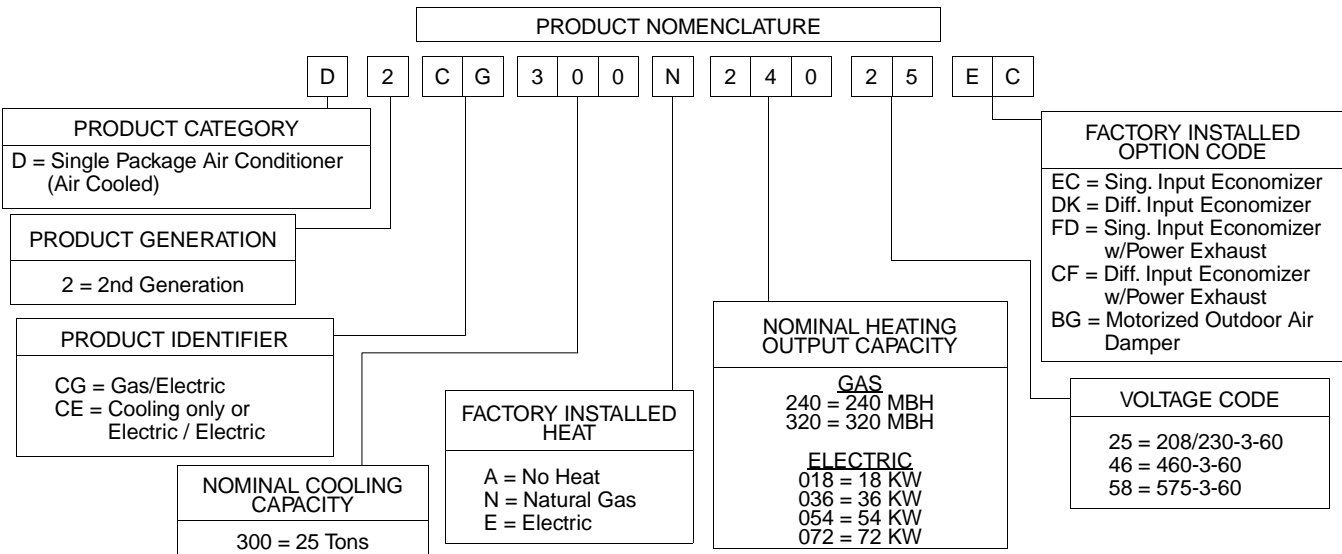

INSTALLATION

LIMITATIONS

These units must be installed in accordance with the following applicable national and local safety codes:

In U.S.A.:

1. National Electrical Code ANSI/NFPA No. 70.
2. National Fuel Gas Code Z223.1.
3. Gas-Fired Central Furnace Standard ANSI Z21.47a.
4. Local gas and electric utility requirements.

In Canada:

1. Current Canadian Electrical Code C22.1.
2. Current Gas Installation Codes CAN/CGA-B149.1 and .2
3. Local plumbing and waste water codes.
4. Other applicable local codes.

Refer to the Unit Application Data Table and to the Gas Heat Application Data Table.

After installation, units with gas heat must be adjusted to obtain a temperature rise within the range specified on the unit rating plate. If components are to be added to a unit to meet local codes, they are to be installed at the dealer's and/or the customer's expense.

Size of unit for proposed installation should be based on heat loss/heat gain calculation made according to the methods of the Air Conditioning Contractors of America (ACCA).

This furnace is not to be used for temporary heating of buildings or structures under construction.

TABLE 1 - UNIT APPLICATION DATA

| | | |
|---|----------------|-----------|
| Voltage Variation, Min. / Max. ¹ | 208/230-3-60 | 187 / 253 |
| | 460-3-60 | 414 / 506 |
| | 575-3-60 | 518 / 630 |
| Supply Air CFM, Min. / Max. | 8,000 / 12,000 | |
| Wet Bulb Temperature (°F) of Air on Evaporator Coil, Min. / Max. | 57 / 72 | |
| Dry Bulb Temperature (°F) of Air on Condenser Coil, Min. ² / Max. | 25 / 120 | |

¹Utilization range "A" in accordance with ARI Standard 110.

²A low ambient accessory is available for applications down to 0°F.

LOCATION

Use the following guidelines to select a suitable location for these units.

1. Unit is designed for outdoor installation only.
2. Condenser coils must have an unlimited supply of air. Where a choice of location is possible, position the unit on either north or east side of building.
3. For ground level installation, use a level concrete slab with a minimum thickness of 4 inches. The length and width should be at least 6 inches greater than the unit base rails. Do not tie slab to the building foundation.

WARNING: Excessive exposure of this furnace to contaminated combustion air may result in equipment damage or personal injury. Typical contaminants include: permanent wave solutions, chlorinated waxes and cleaners, chlorine based swimming pool chemicals, water softening chemicals, carbon tetrachloride, Halogen type refrigerants, cleaning solvents (e.g. perchloroethylene), printing inks, paint removers, varnishes, hydrochloric acid, cements and glues, antistatic fabric softeners for clothes dryers, masonry acid washing materials.



4. Roof structures must be able to support the weight of the unit and its options and/or accessories. Unit must be installed on a solid level roof curb or appropriate angle iron frame.

CAUTION: If a unit is to be installed on a roof curb or special frame, gasketing must be applied to all surfaces that come in contact with the unit underside.

5. Maintain level tolerance to 1/2" maximum across the entire length or width of the unit.

RIGGING AND HANDLING

Exercise care when moving the unit. Do not remove any packaging until the unit is near the place of installation. Rig the unit by attaching chain or cable slings to the round lifting holes provided in the base rails. Spreaders, whose length exceeds the largest dimension across the unit, **MUST** be used across the top of the unit.

Units may also be moved or lifted with a forklift, from the front or rear only, providing that an accessory skid is used.

LENGTH OF FORKS MUST BE A MINIMUM OF 90".

CAUTION: On gas heating units, an adhesive backed label is provided over the outside of the combustion air inlet opening to prevent moisture from entering the unit which could cause damage to electrical components. Allow this closure label to remain in place until the combustion air hood is to be installed.

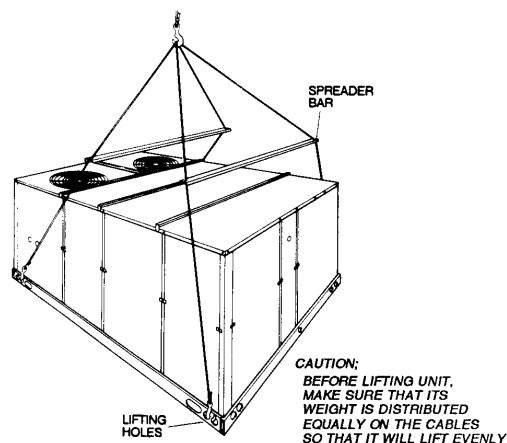

FIG. 1 - TYPICAL RIGGING

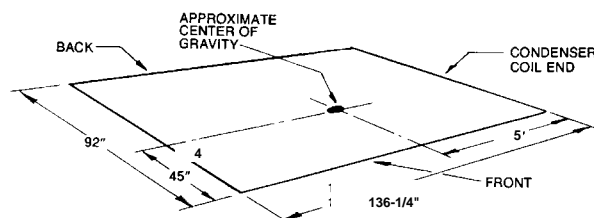

FIG. 2 - CENTER OF GRAVITY

CLEARANCES

All units require certain clearances for proper operation and service. Installer must make provisions for adequate combustion and ventilation air in accordance with [Section 5.3, Air for Combustion and Ventilation of the National Fuel Gas Code, ANSI Z223.1](#) (in U.S.A.) or [Sections 7.2, 7.3 or 7.4 of Gas Installation Codes CAN/CGA-B149.1 and .2](#) (in Canada) and/or applicable provisions of the local building codes. Refer to Dimensions and Clearances table for the clearances required for combustible construction, servicing, and proper unit operation.

WARNING: Do not permit overhanging structures or shrubs to obstruct outdoor air discharge outlet, combustion air inlet or vent outlets.



DUCTWORK

Ductwork should be designed and sized according to the methods in Manual Q of the Air Conditioning Contractors of America (ACCA).

A closed return duct system shall be used. This shall not preclude use of economizers or outdoor fresh air intake. The supply and return air duct connections at the unit should be made with flexible joints to minimize noise.

The supply and return air duct systems should be designed for the CFM and static requirements of the job. They should **NOT** be sized to match the dimensions of the duct connections on the unit.

CAUTION: When fastening ductwork to side duct flanges on unit, insert screws through duct flanges only. DO NOT insert screws through casing.

Outdoor ductwork must be insulated and waterproofed.

Refer to the Dimensions and Clearances figure for information concerning side and bottom supply and return air duct openings.

It is recommended that, in Canada, the outlet duct on gas heating units be provided with a removable access panel. It is recommended that this opening be accessible when the unit is installed in service, and of a size such that smoke or reflected light may be observed inside the casing to indicate the presence of leaks in the heat exchanger. The cover should be attached in a manner adequate to prevent leakage.

FIXED OUTDOOR AIR INTAKE DAMPER

This damper is shipped inside the return air compartment on units that are not provided with an economizer or a motorized damper option. It is completely assembled and ready for installation. A damper baffle inside of the hood is adjustable to provide variable amounts of outdoor air intake.

Gasketing and mounting screws are provided in a parts bag attached to the hood assembly. Apply gasketing to the three flange surfaces on the hood prior to installing the hood. Extend gasketing 1/4" beyond the top and bottom of the two side flanges to insure adequate sealing.

Adjusting the damper to the desired air flow may be done before mounting the hood into position or (after installation) by removing the front hood panel or the screen on the bottom of the hood. Damper baffle in position 1 will allow approximately 10% recirculated air flow, position 2 approximately 15% and, to allow approximately 25%, remove the damper baffle.

On units with bottom return air applications, install the damper assembly over the opening in the side return air access panel. Remove and discard the opening cover and the covering over the hood mounting holes (used for shipping) before installing. Secure with the screws provided.

On units with side return air applications, install the damper assembly on the return air ductwork as close to the unit as possible. Cut an opening 16" high by 18" wide in the ductwork to accommodate the damper. Using the holes in the hood flanges as a template, drill 9/64" dia. (#26 drill) holes into the ductwork and secure with the screws provided.

CAUTION: If outdoor air intake will not be required on units with bottom return air applications, the damper assembly should still be mounted on the side return air access panel, per the instructions above, to insure moisture is not drawn into the unit during operation. The covering over the mounting holes only need be removed. Do not remove the opening cover.

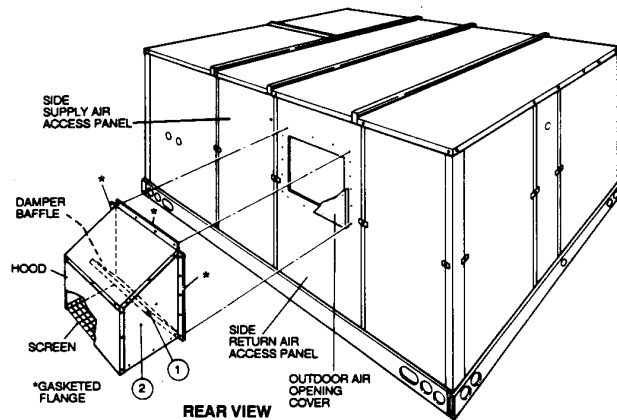

FIG. 3 - FIXED OUTDOOR AIR DAMPER

CONDENSATE DRAIN

Plumbing must conform to local codes. Use a sealing compound on male pipe threads. Install a condensate drain line from the 1" NPT female connection on the unit to an open drain.

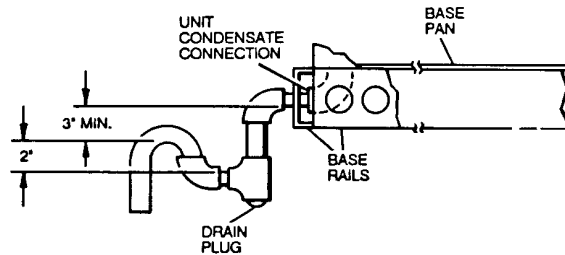

FIG. 4 - RECOMMENDED DRAIN PIPING

NOTE: The condensate drain line **MUST** be trapped to provide proper drainage.

COMPRESSORS

Units are shipped with compressor mountings factory-adjusted and ready for operation.

CAUTION: Do Not loosen compressor mounting bolts.

FILTERS

2" filters are supplied with each unit. Filters must always be installed ahead of the evaporator coil and must be kept clean or replaced with same size and type. Dirty filters will reduce the capacity of the unit and will result in frosted coils or safety shutdown. Minimum filter area and required sizes are shown in the Physical Data Table.

SERVICE ACCESS

Access to all serviceable components is provided by the following removable panels:

- Compressor compartment
- Electric Heat compartment - DCE models
- Gas Heat compartment (Two panels) - DCG models
- Side Supply & Return Air compartments (Two panels)
- Blower compartment (Three panels)
- Main control box
- Filter compartment
- Outdoor Air compartment (Two panels)

Refer to the Dimensions and Clearances figure for location of these access panels.

CAUTION: Make sure that all screws and panel latches are replaced and properly positioned on the unit to maintain an air-tight seal.

CONTROL WIRING

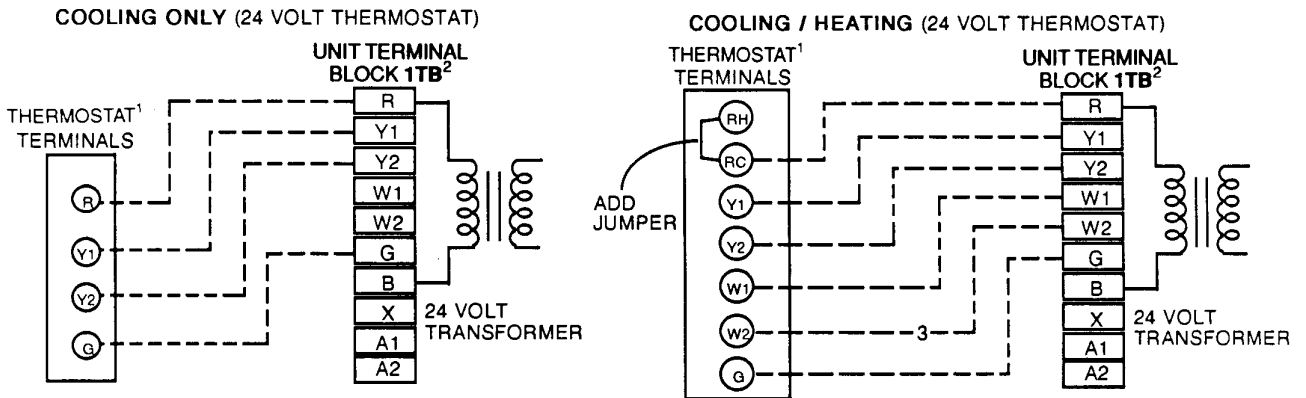

¹24 Volt Thermostat 2TH04701224.
²Terminal block 1TB - located on relay board in 24-volt section of the unit control box.

¹24 Volt Thermostat 2TH04701024 or 2TH04701524 (with Subbase 2TB04700224 or 2TB04700324).
²Terminal block 1TB - located on relay board in 24-volt section of the unit control box.
³Second stage heating is not required on units with a single stage electric heater.

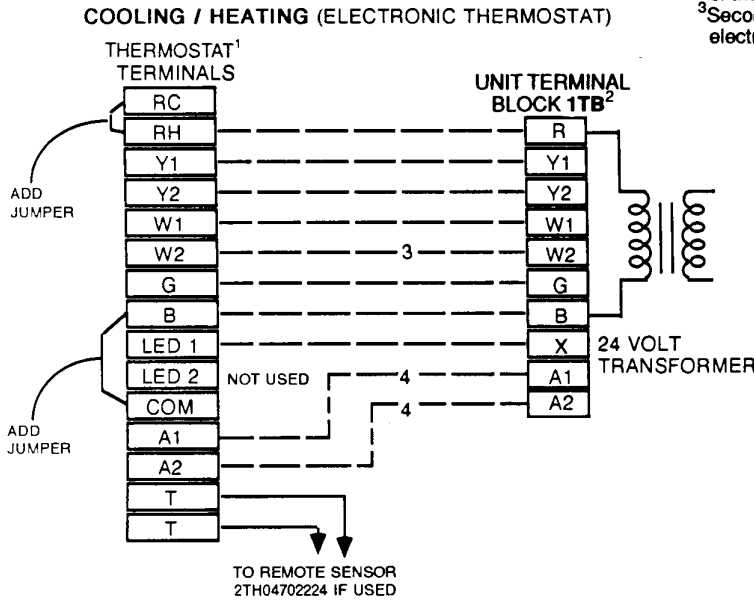

¹Electronic programmable Thermostat 2ET04700224 (includes subbase).
²Terminal block 1TB - located on relay board in 24-volt section of the unit control box.
³Second stage heating is not required on units with a single stage electric heater.
⁴Terminals A1 and A2 provide a relay output to close the outdoor economizer dampers when the thermostat switches to the set-back position.

Fan switch must be in "ON" position for minimum ventilation during heater operation.

POWER WIRING

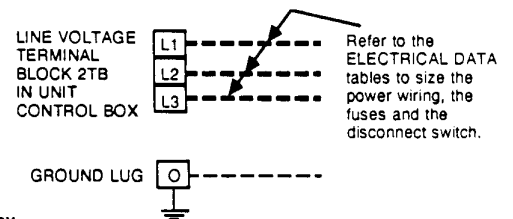

CONTROL WIRE SIZES

| Wire Size ¹ AWG. Gauge | | | | |
|---------------------------------------|----|----|----|-----|
| 22 | 20 | 19 | 18 | 16 |
| 25 | 40 | 50 | 65 | 100 |
| Maximum Wire Length ² Feet | | | | |

Notes:
 1. Solid, Class II copper wire

FIG. 5 - TYPICAL FIELD WIRING

THERMOSTAT

The room thermostat should be located on an inside wall approximately 56" above the floor where it will not be subject to drafts, sun exposure or heat from electrical fixtures or appliances. Follow manufacturer's instructions enclosed with thermostat for general installation procedure. Seven color coded insulated wires should be used to connect thermostat to unit.

POWER AND CONTROL WIRING

Field wiring to the unit must conform to provisions of the National Electrical Code, ANSI / NFPA No. 70 (in U.S.A.), current Canadian Electrical Code C22.1 (in Canada) and/or local ordinances. The unit must be electrically grounded in accordance with NEC and CEC (as specified above) and/or local codes. Voltage tolerances which must be maintained at the compressor terminals during starting and running conditions are indicated on the unit Rating Plate.

The internal wiring harness furnished with this unit is an integral part of a ETL and CGA design certified unit. Field alteration to comply with electrical codes should not be required.

A fused disconnect switch should be field provided for the unit. The switch must be separate from all other circuits. Wire entry at knockout openings require conduit fittings to comply with NEC (in U.S.A.), CEC (in Canada) and/or local codes. If any of the wire supplied with the unit must be replaced, replacement wire must be of the type shown on the wiring diagram and the same minimum gauge as the replaced wire.

Electrical line must be sized properly to carry the load. Each unit must be wired with a separate branch circuit fed directly from the meter panel and properly fused.

CAUTION: When connecting electrical power and control wiring to the unit, waterproof type connectors **MUST BE USED** so that water or moisture cannot be drawn into the unit during normal operation. The above waterproofing conditions will also apply when installing a field-supplied disconnect switch.

Refer to Typical Field Wiring Figure for typical field wiring and to the appropriate unit wiring diagram for control circuit and power wiring information.

OPTIONAL ELECTRIC HEATERS (DCE Models)

The factory installed heaters are wired for single point power supply. Power supply need only be brought into the single point terminal block and thermostat wiring to the low voltage terminal block located in the upper portion of the unit control box.

These ETL and CGA approved heaters are located within the central compartment of the unit with the heater elements extending into the supply air chamber. Refer to the Dimension and Clearances figure for access panel location.

Fuses are supplied, where required, by the factory. Some KW sizes require fuses and others do not. Refer to the Unit Application Data Table 1 for minimum CFM limitations and to Electrical Data Table.

TABLE 2 - GAS HEAT APPLICATION DATA

| Input Capacity (Mbh) | | | | Output Capacity (Mbh) | | Gas Rate ² (Ft. ³ /Hr.) | Temp. Rise °F At Full Input ³ | |
|---------------------------------|------|--|------|---------------------------------|--|---|--|------|
| 0 To 2,000 Feet Above Sea Level | | 2,000 To 4,500 Feet Above Sea Level ¹ | | 0 To 2,000 Feet Above Sea Level | 2,000 To 4,500 Feet Above Sea Level ¹ | | Min. | Max. |
| Max. | Min. | Max. | Min. | Max. | Max. | | | |
| 300 | 150 | 270 | 135 | 240 | 213 | 279 | 20 | 50 |
| 400 | 200 | 360 | 180 | 320 | 281 | 372 | 30 | 60 |

NOTE: Heaters are shipped available for natural gas, but can be converted to L.P. / Propane with Kit Model No. 1NP0418.
¹MBH rating should be reduced at the rate of 4 percent for each 1,000 feet above 4,500 feet.
²Based on maximum input and 1075 Btu/Ft³.
³The air flow must be adjusted to obtain a temperature rise within the range shown.

COMBUSTION DISCHARGE (DCG Models)

The products of combustion are discharged horizontally through two screened (hooded) openings on the upper gas heat access panel.

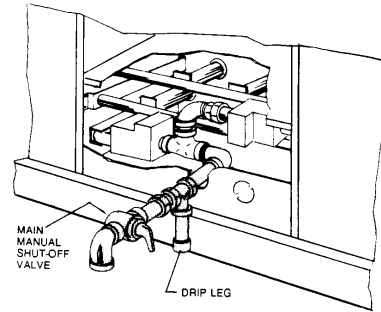

FIG. 6 - EXTERNAL SUPPLY CONNECTION EXTERNAL SHUT-OFF

GAS PIPING (DCG Models)

Proper sizing of gas piping depends on the cubic feet per hour of gas flow required, specific gravity of the gas and the length of run. "National Fuel Gas Code" Z223.1 (in U.S.A.) or the current Gas Installation Codes CAN/CGA-B149.1 and .2 (in Canada) should be followed in all cases unless superseded by local codes or gas utility requirements. See Pipe Sizing table.

The heating value of the gas may differ with locality. The value should be checked with the local gas utility.

NOTE: There may be a local gas utility requirement specifying a minimum diameter for gas piping. All units require a 1 inch pipe connection at the entrance fitting.

TABLE 3 - PIPE SIZING

| Length in Feet | Nominal Iron Pipe Size | |
|----------------|------------------------|-----------|
| | 1 in. | 1-1/4 in. |
| 10 | 520 | 1,050 |
| 20 | 350 | 730 |
| 30 | 285 | 590 |
| 40 | 245 | 500 |
| 50 | 215 | 440 |
| 60 | 195 | 400 |
| 70 | 180 | 370 |
| 80 | 170 | 350 |
| 90 | 160 | 320 |
| 100 | 150 | 305 |

Maximum capacity of pipe in cubic feet of gas per hour. (Based upon a pressure drop of 0.3 inch water column and 0.6 specific gravity gas).

GAS CONNECTION (DCG Models)

The gas supply line can be routed through the knockouts located on the front of the unit or through the opening provided in the unit's base. Typical supply piping arrangements are shown in the Supply Connection figures. All pipe, fittings, etc. are field-supplied.

Two grommets are shipped in the blower compartment (in parts bag taped to the blower housing) of every unit with gas heat and should be used in the knockouts when the gas piping enters through the front of the unit.

After the gas supply piping has been installed, the bottom opening in the unit should be sealed to prevent water from leaking into the building.

Gas piping recommendations:

1. A drip leg and a ground joint union must be installed in the gas piping.
2. When required by local codes, a manual shut-off valve may have to be installed outside of the unit.
3. Use wrought iron or steel pipe for all gas lines. Pipe compound should be applied sparingly to male threads only.

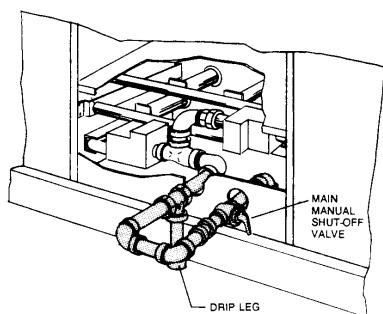

**FIG. 7 - BOTTOM SUPPLY CONNECTION
EXTERNAL SHUT-OFF**

WARNING: *Natural gas may contain some propane. Propane, being an excellent solvent, will quickly dissolve white lead or most standard commercial compounds. Therefore, a special pipe compound must be applied when wrought iron or steel pipe is used. Shellac base compounds such as Gaskolac or Stalastic, and compounds such as Rectorseal #5, Cyde's or John Crane may be used.*



4. All piping should be cleaned of dirt and scale by hammering on the outside of the pipe and blowing out the loose dirt and scale. Before initial start-up, be sure that all of the gas lines external to the unit have been purged of air.
5. The gas supply should be a separate line and installed in accordance with all safety codes as prescribed under "Limitations". After the gas connections have been completed, open the main shut-off valve admitting *normal gas pressure* to the mains. Check all joints for leaks with soap solution or other material suitable for the purpose. **NEVER USE A FLAME.**
6. The furnace and its individual manual shut-off valve must be disconnected from the gas supply piping system during any pressure testing of that system at test pressures in excess of 1/2 psig (3.48kPa).
The furnace must be isolated from the gas supply piping system by closing its individual manual shut-off valve during any pressure testing of the gas supply piping system at test pressures equal to or less than 1/2 psig (3.48kPa).
7. A 1/8 inch NPT plugged tapping, accessible for test gage connection, must be installed immediately upstream of the gas supply connection to the furnace.

L.P. UNITS, TANKS AND PIPING (DCG Models)

All gas heat units are shipped from the factory equipped for natural gas use only. The unit may be converted in the field for use with L.P./propane gas with accessory kit model number 1NP0418.

All L.P./propane gas equipment must conform to the safety standards of the National Fire Protection Association.

For satisfactory operation, L.P./propane gas pressure must be 8.8 inch W.C at the unit under full load. Maintaining proper gas pressure depends on three main factors:

1. The vaporization rate which depends on (a) the temperature of the liquid and (b) the "wetted surface" area of the container or containers.
2. The proper pressure regulation. (Two-stage regulation is recommended from the standpoint of both cost and efficiency.)
3. The pressure drop in the lines between regulators and between the second stage regulator and the appliance. Pipe size required will depend on the length of the pipe run and the total load of all appliances.

Complete information regarding tank sizing for vaporization, recommended regulator settings, and pipe sizing is available from most regulator manufacturers and L.P./propane gas suppliers.

L.P./propane gas is an excellent solvent and special pipe compound must be used when assembling piping for this gas as it will quickly dissolve white lead or most standard commercial compounds. Shellac base compounds such as Rectorseal #5 are satisfactory for this type of gas.

Check all connections for leaks when piping is completed, using a soap solution. **NEVER USE A FLAME.**

VENT AND COMBUSTION AIR HOODS (DCG Models)

Two vent hoods and a combustion air hood (with screens) are shipped attached to the blower housing in the blower compartment. These hoods must be installed to assure proper unit function. All hoods must be fastened to the outside of the gas heat access panel with the screws provided in the bag also attached to the blower housing.

The screen for the combustion air intake hood is secured to the inside of the access panel opening with four fasteners and the screws used for mounting the hood to the panel. The top flange of this hood slips in under the top of the access panel opening when installing. Refer to the Vent and Combustion Hood figure.

Each vent hood is installed by inserting the top flange of the hood into the slotted opening in the access panel and securing in place.

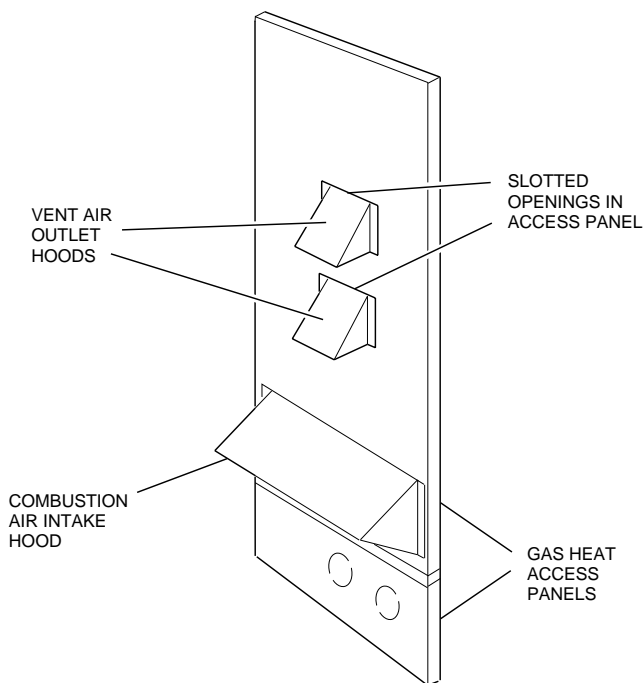

FIG. 8 - VENT AND COMBUSTION AIR HOODS

OPTIONAL ECONOMIZER/MOTORIZED DAMPER RAIN HOOD

The instruction for the optional economizer/motorized damper rain hood can be found in form 44-320-2. Use these instructions when field assembling an economizer rain hood onto a unit. The outdoor and return air dampers, the damper actuator, the damper linkage, the outdoor and return air divider baffles, and all the control sensors are factory mounted as part of the "Factory installed" economizer option.

ENTHALPY SET POINT ADJUSTMENT

Remove the economizer access panel from the unit to check the following adjustments. Loosen but do not remove the two panel latches.

CAUTION: *Extreme care must be exercised in turning both the setpoint and minimum position adjusting screws to prevent twisting them off.*

1. The enthalpy set point may now be set by selecting the desired setpoint shown in the Enthalpy figure. Adjust as follows:
 - For a single enthalpy operation, carefully turn the set point adjusting screw to the "A", "B", "C" or "D" setting corresponding to the lettered curve.
 - For a dual enthalpy operation, carefully turn the set point adjusting screw fully clockwise past the "D" setting.
2. To check that the damper blades move smoothly without binding, carefully turn the minimum position adjusting screw fully clockwise and then energize and de-energize terminals "R" to "G". With terminals "R" to "G" energized, turn the minimum position screw counterclockwise until the desired minimum position has been attained.
3. Replace the economizer access panel. Reposition the two latches horizontally and retighten the screws.

POWER EXHAUST/BAROMETRIC RELIEF DAMPER AND RAIN HOOD OPTION

The instructions for the power exhaust/barometric relief damper and rain hood can be found in form 44-320-10. The exhaust fan, all supporting brackets, angles, and the wiring are factory installed as part of the power exhaust option.

All of the components, including the dampers, hardware, and mounting instructions are shipped in a single package external from the unit. The hood must be field assembled and installed.

Power exhaust is not available as a field installed option.

| CONTROL CURVE | CONTROL POINT (APPROX. DEG.) AT 50% RH |
|---------------|--|
| A | 73 [23] |
| B | 70 [21] |
| C | 67 [19] |
| D | 63 [17] |

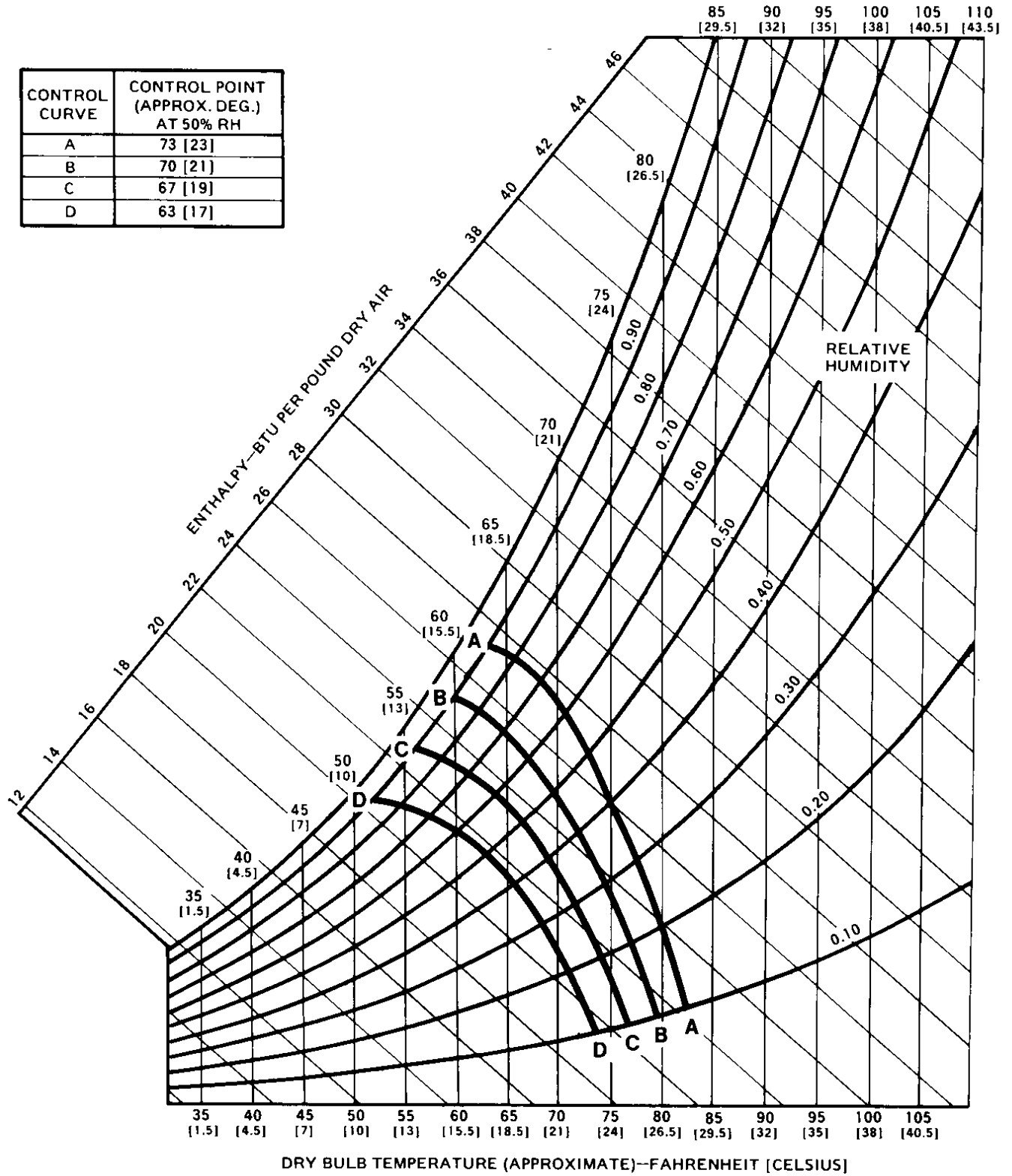

FIG. 9 - ENTHALPY SETPOINT ADJUSTMENT

TABLE 4 - PHYSICAL DATA

| MODELS | | | DCE/DCG | OPERATING WEIGHTS (LBS.) | | 25 TON | |
|------------------------------|-------------------------------------|--------------|---------|--------------------------|---------------------------------------|--------|------|
| | | | 300 | | | | |
| EVAPORATOR BLOWER | CENTRIFUGAL BLOWER (Dia. x Wd. in.) | | 18 x 15 | Basic Unit | DCE (Cooling only) | | 2730 |
| | FAN MOTOR HP | | 15 | | DCG (Gas / Electric) | N240 | 2930 |
| | | | | | N320 | 2970 | |
| EVAPORATOR COIL | ROWS DEEP | | 4 | Options | Economizer | | 160 |
| | FINS PER INCH | | 13.5 | | Economizer with Power Exhaust | | 245 |
| | FACE AREA (Sq. Ft.) | | 25.0 | | Motorized Damper | | 150 |
| CONDENSER FAN (Two Per Unit) | PROPELLER DIA. (in.) (Each) | | 30 | | Electric Heater (DCE only) | 18 KW | 25 |
| | FAN MOTOR HP (Each) | | 1 | | | 36 KW | 30 |
| NOM. CFM TOTAL (Each) | | 7200 | 54 KW | 35 | | | |
| | | | 72 KW | 40 | | | |
| CONDENSER COIL | ROWS DEEP | | 3 | Accessories | Roof Curb | | 185 |
| | FINS PER INCH | | 15 | | Barometric Damper | | 45 |
| | FACE AREA (Sq. Ft.) | | 43.3 | | Economizer/Motorized Damper Rain Hood | | 55 |
| COMPRESSOR (Qty. Per Unit) | 12.5-TON TANDEM | | 2 | | Economizer/Power Exhaust Rain Hood | | 90 |
| | | | | | Wood Skid | | 220 |
| AIR FILTERS | QUANTITY PER UNIT (16" X 20" X 2") | | 2 | | | | |
| | QUANTITY PER UNIT (16" X 25" X 2") | | 4 | | | | |
| | QUANTITY PER UNIT (14" X 20" X 2") | | 3 | | | | |
| | TOTAL FACE AREA (sq. ft.) | | 21.4 | | | | |
| CHARGE | REFRIGERANT | SYSTEM NO. 1 | 20/8 | | | | |
| | | SYSTEM NO. 2 | 20/0 | | | | |

*This compressor will be energized first.

TABLE 5 - ELECTRICAL DATA - BASIC UNITS

| MODEL NO. | POWER SUPPLY | COMPRESSORS | | COND. FAN | | SUPPLY AIR BLOWER MOTOR | | MINIMUM CIRCUIT AMPACITY (AMPS) | MAXIMUM OVERCURRENT DEVICE (1) (AMPS) |
|-------------------|--------------|-------------|-----------|-----------|-----------|-------------------------|------|---------------------------------|---------------------------------------|
| | | (QTY. 2) | | (#1 & #2) | | HP | RLA | | |
| | | RLA (ea.) | LRA (ea.) | HP (ea.) | FLA (ea.) | | | | |
| D2CE300 & D2CG300 | 208/230-3-60 | 41.4 | 312 | 1 | 4.2 | 15 | 38.6 | 139.5 | 175 |
| | 460-3-60 | 20.0 | 140 | 1 | 2.1 | 15 | 19.3 | 68.3 | 80 |
| | 575-3-60 | 16.4 | 108 | 1 | 2.0 | 15 | 15.4 | 56.1 | 70 |

| VOLTAGE LIMITATIONS** | POWER SUPPLY | VOLTAGE | |
|-----------------------|--------------|---------|------|
| | | MIN. | MAX. |
| | 208/230-3-60 | 187 | 253 |
| 460-3-60 | 414 | 506 | |
| 575-3-60 | 518 | 630 | |

**Utilization Range "A" in accordance with ARI Standard 110.

TABLE 6 - ELECTRICAL DATA - UNITS w/ELECTRIC HEAT

| MODEL D2CE | POWER SUPPLY | ELECTRIC HEATER OPTION | | | | MINIMUM CIRCUIT AMPACITY (AMPS) | MAXIMUM OVERCURRENT DEVICE (1) (AMPS) |
|------------|--------------|------------------------|-------|--------|-------|---------------------------------|---------------------------------------|
| | | MODEL | KW(1) | STAGES | AMPS | | |
| 300A25 | 208-3-60 | E018 | 13.5 | 1 | 37.5 | 139.5 | 175 |
| 300A25 | 208-3-60 | E036 | 27.0 | 2 | 75.1 | 142.1 | 175 |
| 300A25 | 208-3-60 | E054 | 40.6 | 2 | 112.6 | 189.0 | 200 |
| 300A25 | 208-3-60 | E072 | 54.1 | 2 | 150.1 | 198.4 | 225 |
| 300A25 | 230-3-60 | E018 | 18.0 | 1 | 43.3 | 139.5 | 175 |
| 300A25 | 230-3-60 | E036 | 36.0 | 2 | 86.6 | 156.5 | 175 |
| 300A25 | 230-3-60 | E054 | 54.0 | 2 | 129.9 | 178.2 | 200 |
| 300A25 | 230-3-60 | E072 | 72.0 | 2 | 173.2 | 221.5 | 250 |
| 300A46 | 460-3-60 | E018 | 18.0 | 1 | 21.7 | 68.3 | 80 |
| 300A46 | 460-3-60 | E036 | 36.0 | 2 | 43.3 | 78.3 | 80 |
| 300A46 | 460-3-60 | E054 | 54.0 | 2 | 65.0 | 89.1 | 100 |
| 300A46 | 460-3-60 | E072 | 72.0 | 2 | 86.6 | 110.7 | 125 |
| 300A58 | 575-3-60 | E018 | 18.0 | 1 | 17.3 | 56.1 | 70 |
| 300A58 | 575-3-60 | E036 | 36.0 | 2 | 34.6 | 62.6 | 70 |
| 300A58 | 575-3-60 | E054 | 54.0 | 2 | 52.0 | 71.2 | 80 |
| 300A58 | 575-3-60 | E072 | 72.0 | 2 | 69.3 | 88.5 | 100 |

| NOMINAL VOLTAGE | VOLTAGE | KW CAP. MULTIPLIER |
|-----------------|---------|--------------------|
| 208 | 208 | 1.00 |
| 240 | 230 | 0.92 |
| 480 | 460 | 0.92 |
| 600 | 575 | 0.92 |

All dimensions are in inches. They are subject to change without notice. Certified dimensions will be provided upon request.

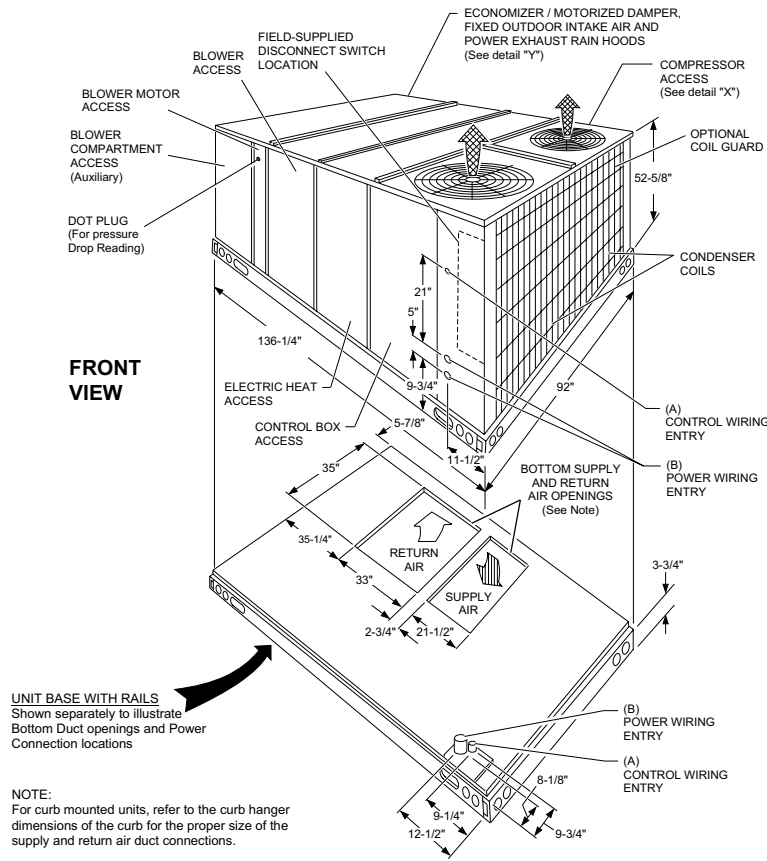

UNIT BASE WITH RAILS
Shown separately to illustrate Bottom Duct openings and Power Connection locations

NOTE:
For curb mounted units, refer to the curb hanger dimensions of the curb for the proper size of the supply and return air duct connections.

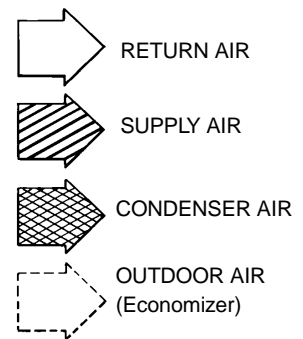

UTILITIES ENTRY DATA

| HOLE | OPENING SIZE (DIA.) | USED FOR | |
|------|---------------------|----------------------|--------|
| | | Control Wiring | Front |
| A | 1-1/8" KO | | Bottom |
| | 3/4" NPS (Fem.) | | Front |
| B | 3-5/8" KO | | Bottom |
| | 3" NPS (Fem.) | | Front |
| C | 2-3/8" KO | Gas Piping (Front) | |
| D | 1-11/16" Hole | Gas Piping (Bottom)* | |

*Opening in the bottom of the unit can be located by the slice in the insulation.

CLEARANCES

| | |
|---------------------------|--|
| Front | 36" |
| Back | 24" (Less Economizer) 49" (With Economizer) |
| Left Side (Filter Access) | 24" (Less Economizer) 36" ³ (With Economizer) |
| Right Side (Cond. Coil) | 36" |
| Below Unit ¹ | 0" |
| Above Unit ² | 72" With 36" Maximum Horizontal Overhang (For Condenser Air Discharge) |

- ¹Units (applicable in U.S.A. only) may be installed on combustible floors made from wood or class A, B or C roof covering material.
- ²Units must be installed outdoors. Overhanging structures or shrubs should not obstruct condenser air discharge outlet.
- ³If economizer is factory installed, the assembled hood kit must be removed prior to final installation. This hood is 54" long.

NOTE:
DCE Models: Units and ductwork are approved for zero clearance to combustible materials when equipped with electric heaters.

DCG Models: A 1" clearance must be provided between any combustible material and the supply air ductwork for a distance of 3 feet from the unit.

The products of combustion must not be allowed to accumulate within a confined space and recirculate.

- Locate unit so that the vent air outlet hood is at least:
- Three (3) feet above any forced air inlet located within 10 horizontal feet (excluding those integral to the unit).
 - Four (4) feet below, 4 horizontal feet from, or 1 foot above any door or gravity air inlet into the building.
 - Four (4) feet from electric meters, gas meters, regulators and relief equipment.

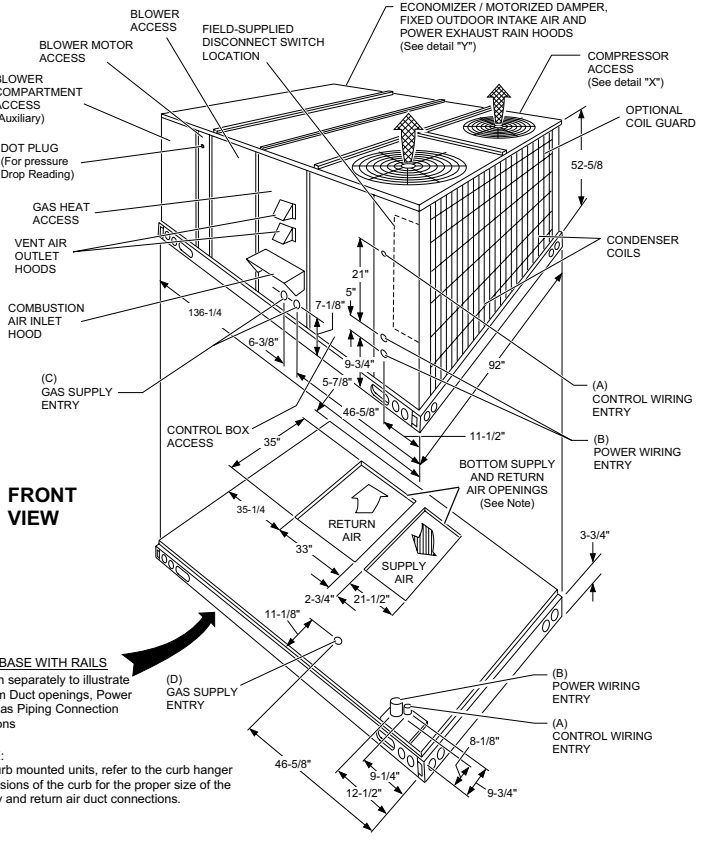

UNIT BASE WITH RAILS
Shown separately to illustrate Bottom Duct openings, Power and Gas Piping Connection locations

NOTE:
For curb mounted units, refer to the curb hanger dimensions of the curb for the proper size of the supply and return air duct connections.

FIG. 10 - DIMENSIONS & CLEARANCES - DCE & DCG

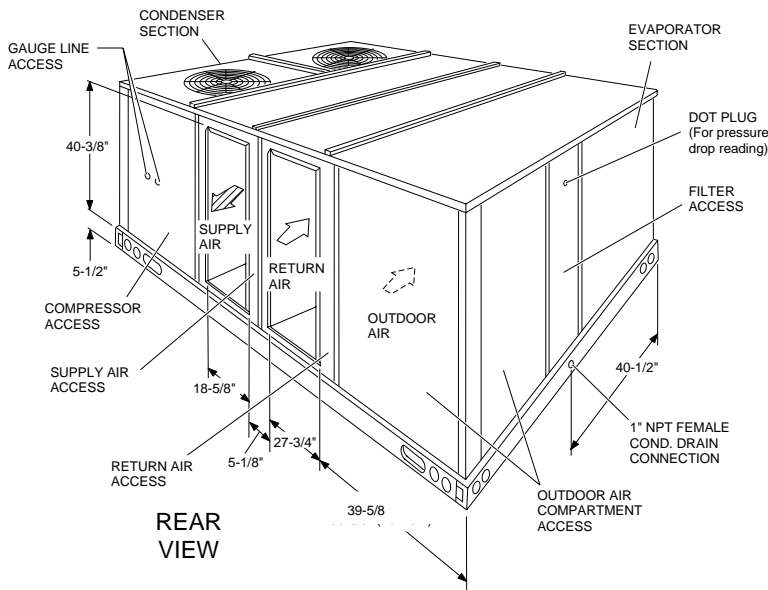

DUCT COVERS - Units are shipped with the bottom duct openings covered. An accessory flange kit is available for connecting side ducts.

For **bottom** duct applications:

1. Remove the side panels from the supply and return air compartments to gain access to the bottom supply and return air duct covers.
2. Remove and discard the bottom duct covers. (Duct openings are closed with sheet metal covers except when the unit includes a power exhaust option. The covering consists of a heavy black paper composition.)
3. Replace the side supply and return air compartment panels.

For **side** duct applications;

1. Replace the side panels on the supply and return air compartments with the accessory flange kit panels.
2. Connect ductwork to the duct flanges on the rear of the unit.

DETAIL "X"

ACCESSORY SIDE SUPPLY AND RETURN AIR OPENINGS

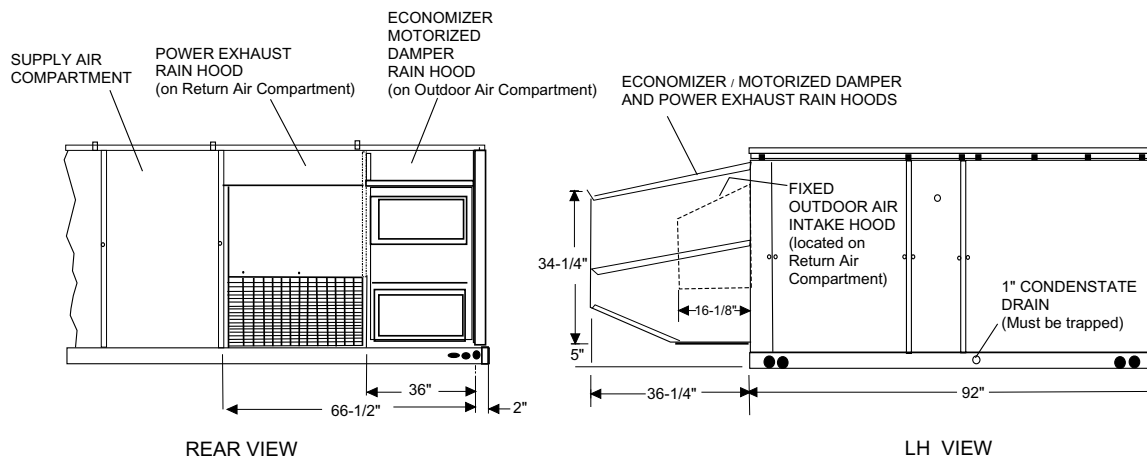

DETAIL "Y"
UNIT WITH RAIN HOODS

DETAIL "Y"
UNIT WITH RAIN HOODS

FIG. 10 - DIMENSIONS & CLEARANCES (Cont'd.)- DCE & DCG

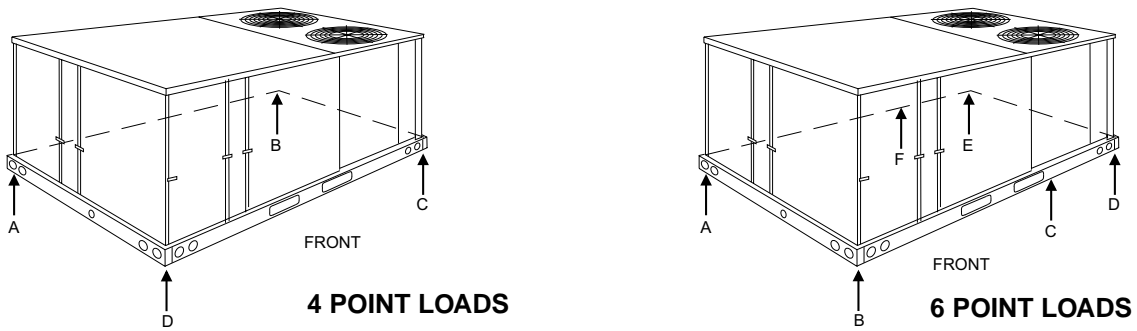

FIG. 11- FOUR AND SIX POINT LOADS

TABLE 7 - FOUR AND SIX POINT LOADS

| UNIT | 4 - POINT LOADS (LBS) | | | | |
|------|-----------------------|-----|-----|-----|-----|
| | TOTAL | A | B | C | D |
| 300 | 3,130 | 615 | 671 | 962 | 882 |

NOTE: These weights are with economizer, high heat, and the largest blower motor available.

| UNIT | 6 - POINT LOADS (LBS) | | | | | | |
|------|-----------------------|-----|-----|-----|-----|-----|-----|
| | TOTAL | A | B | C | D | E | F |
| 300 | 3,130 | 418 | 438 | 533 | 628 | 603 | 510 |

NOTE: These weights are with economizer, high heat, and the largest blower motor available.

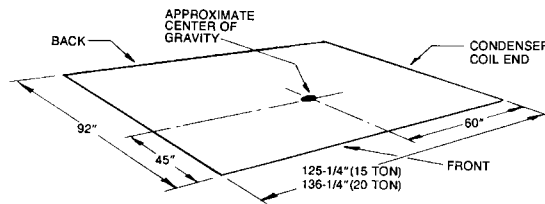

TABLE 8 - SUPPLY AIR BLOWER PERFORMANCE DCE300- BOTTOM DUCT CONNECTIONS (COOLING APPLICATIONS)

| BLOWER SPEED (rpm) | PULLEY TURNS OPEN: | 7500 CFM | | | 8750 CFM | | | 10000 CFM | | | 11250 CFM | | | 12500 CFM | | |
|--------------------|--------------------|-----------|--------------|------------|-----------|--------------|------------|-----------|--------------|------------|-----------|--------------|------------|-----------|--------------|------------|
| | | ESP (iwg) | OUTPUT (bhp) | INPUT (kW) | ESP (iwg) | OUTPUT (bhp) | INPUT (kW) | ESP (iwg) | OUTPUT (bhp) | INPUT (kW) | ESP (iwg) | OUTPUT (bhp) | INPUT (kW) | ESP (iwg) | OUTPUT (bhp) | INPUT (kW) |
| STANDARD DRIVE: | | | | | | | | | | | | | | | | |
| 975 | 6.0* | 1.4 | 5.9 | 4.9 | 1.0 | 7.3 | 6.0 | 0.5 | 8.8 | 7.2 | - | - | - | - | - | - |
| 1005 | 5.0 | 1.6 | 6.2 | 5.1 | 1.2 | 7.7 | 6.3 | 0.7 | 9.2 | 7.6 | 0.1 | 10.9 | 8.9 | - | - | - |
| 1040 | 4.0 | 1.8 | 6.6 | 5.4 | 1.4 | 8.1 | 6.7 | 0.9 | 9.7 | 8.0 | 0.3 | 11.4 | 9.4 | - | - | - |
| 1070 | 3.0 | 2.0 | 6.9 | 5.7 | 1.6 | 8.5 | 7.0 | 1.1 | 10.2 | 8.3 | 0.6 | 11.9 | 9.8 | - | - | - |
| 1100 | 2.0 | 2.1 | 7.3 | 6.0 | 1.8 | 8.9 | 7.3 | 1.3 | 10.6 | 8.7 | 0.8 | 12.4 | 10.2 | 0.2 | 14.3 | 11.7 |
| 1135 | 1.0 | 2.4 | 7.7 | 6.3 | 2.0 | 9.3 | 7.6 | 1.6 | 11.1 | 9.1 | 1.0 | 13.0 | 10.6 | 0.4 | 14.9 | 12.2 |
| 1165 | 0.0 | 2.6 | 8.0 | 6.6 | 2.2 | 9.7 | 8.0 | 1.8 | 11.6 | 9.5 | 1.3 | 13.5 | 11.0 | 0.7 | 15.5 | 12.7 |
| ACCESSORY DRIVE: | | | | | | | | | | | | | | | | |
| 1140 | 6.0 | 2.4 | 7.7 | 6.3 | 2.1 | 9.4 | 7.7 | 1.6 | 11.2 | 9.2 | 1.1 | 13.1 | 10.7 | 0.5 | 15.0 | 12.3 |
| 1180 | 5.0 | 2.7 | 8.2 | 6.7 | 2.3 | 9.9 | 8.1 | 1.9 | 11.8 | 9.7 | 1.4 | 13.7 | 11.2 | 0.8 | 15.8 | 12.9 |
| 1215 | 4.0 | 2.9 | 8.6 | 7.0 | 2.6 | 10.4 | 8.5 | 2.2 | 12.3 | 10.1 | 1.7 | 14.3 | 11.7 | 1.1 | 16.4 | 13.5 |
| 1255 | 3.0 | 3.2 | 9.1 | 7.4 | 2.9 | 11.0 | 9.0 | 2.5 | 12.9 | 10.6 | 2.0 | 15.0 | 12.3 | 1.4 | 17.2 | 14.1 |
| 1290 | 2.0 | 3.4 | 9.5 | 7.8 | 3.1 | 11.5 | 9.4 | 2.7 | 13.5 | 11.1 | 2.2 | 15.6 | 12.8 | - | - | - |
| 1330 | 1.0 | 3.7 | 10.0 | 8.2 | 3.4 | 12.0 | 9.9 | 3.0 | 14.1 | 11.6 | 2.6 | 16.4 | 13.4 | - | - | - |
| 1365 | 0.0 | 3.9 | 10.5 | 8.6 | 3.7 | 12.6 | 10.3 | 3.3 | 14.7 | 12.1 | 2.9 | 17.0 | 13.9 | - | - | - |

NOTES:

- Blower performance is based on cooling only unit, with fixed outdoor air, 2" T/A filters and a dry evaporator coil. Refer to page 14 for additional static resistances.
- ESP - External Static Pressure available for the supply and return air duct system. All internal unit resistances have been deducted from the total static pressure of the blower.
- * FACTORY SETTING

TABLE 9 - SUPPLY AIR BLOWER PERFORMANCE DCG300-BOTTOM DUCT CONNECTIONS(COOLING APPLICATIONS)

| BLOWER SPEED (rpm) | PULLEY TURNS OPEN: | 7500 CFM | | | 8750 CFM | | | 10000 CFM | | | 11250 CFM | | | 12500 CFM | | |
|--------------------|--------------------|-----------|--------------|------------|-----------|--------------|------------|-----------|--------------|------------|-----------|--------------|------------|-----------|--------------|------------|
| | | ESP (iwg) | OUTPUT (bhp) | INPUT (kW) | ESP (iwg) | OUTPUT (bhp) | INPUT (kW) | ESP (iwg) | OUTPUT (bhp) | INPUT (kW) | ESP (iwg) | OUTPUT (bhp) | INPUT (kW) | ESP (iwg) | OUTPUT (bhp) | INPUT (kW) |
| STANDARD DRIVE: | | | | | | | | | | | | | | | | |
| 975 | 6.0 | 1.2 | 5.9 | 4.9 | 0.5 | 7.3 | 6.0 | - | - | - | - | - | - | - | - | - |
| 1005 | 5.0 | 1.4 | 6.2 | 5.1 | 0.7 | 7.7 | 6.3 | - | - | - | - | - | - | - | - | - |
| 1040 | 4.0 | 1.6 | 6.6 | 5.4 | 0.9 | 8.1 | 6.7 | 0.2 | 9.7 | 8.0 | - | - | - | - | - | - |
| 1070 | 3.0 | 1.8 | 6.9 | 5.7 | 1.1 | 8.5 | 7.0 | 0.4 | 10.2 | 8.3 | - | - | - | - | - | - |
| 1100 | 2.0 | 2.0 | 7.3 | 6.0 | 1.3 | 8.9 | 7.3 | 0.6 | 10.6 | 8.7 | - | - | - | - | - | - |
| 1135 | 1.0 | 2.2 | 7.7 | 6.3 | 1.6 | 9.3 | 7.6 | 0.8 | 11.1 | 9.1 | - | - | - | - | - | - |
| 1165 | 0.0 | 2.4 | 8.0 | 6.6 | 1.8 | 9.7 | 8.0 | 1.0 | 11.6 | 9.5 | 0.2 | 13.5 | 11.0 | - | - | - |
| ACCESSORY DRIVE: | | | | | | | | | | | | | | | | |
| 1140 | 6.0 | 2.2 | 7.7 | 6.3 | 1.6 | 9.4 | 7.7 | 0.9 | 11.2 | 9.2 | - | - | - | - | - | - |
| 1180 | 5.0 | 2.5 | 8.2 | 6.7 | 1.9 | 9.9 | 8.1 | 1.2 | 11.8 | 9.7 | 0.3 | 13.7 | 11.2 | - | - | - |
| 1215 | 4.0 | 2.7 | 8.6 | 7.0 | 2.1 | 10.4 | 8.5 | 1.4 | 12.3 | 10.1 | 0.6 | 14.3 | 11.7 | - | - | - |
| 1255 | 3.0 | 3.0 | 9.1 | 7.4 | 2.4 | 11.0 | 9.0 | 1.7 | 12.9 | 10.6 | 0.9 | 15.0 | 12.3 | - | - | - |
| 1290 | 2.0 | 3.2 | 9.5 | 7.8 | 2.7 | 11.5 | 9.4 | 2.0 | 13.5 | 11.1 | 1.2 | 15.6 | 12.8 | - | - | - |
| 1330 | 1.0 | 3.5 | 10.0 | 8.2 | 3.0 | 12.0 | 9.9 | 2.3 | 14.1 | 11.6 | 1.5 | 16.4 | 13.4 | - | - | - |
| 1365 | 0.0 | 3.7 | 10.5 | 8.6 | 3.2 | 12.6 | 10.3 | 2.6 | 14.7 | 12.1 | 1.8 | 17.0 | 13.9 | - | - | - |

NOTES:

Blower performance is based on cooling only unit, with fixed outdoor air, 2" T/A filters and a dry evaporator coil. Refer to page 14 for additional static resistances.
 ESP - External Static Pressure available for the supply and return air duct system. All internal unit resistances have been deducted from the total static pressure of the blower.
 * FACTORY SETTING

TABLE 10 - STATIC RESISTANCES*

| DESCRIPTION | AIRFLOW (CFM) | | | | |
|--|---------------|-----------|-----------|-----------|-----------|
| | 7500 | 8750 | 10000 | 11250 | 12500 |
| | ESP (IWG) | ESP (IWG) | ESP (IWG) | ESP (IWG) | ESP (IWG) |
| DEDUCTIONS: (SUBTRACT VALUES BELOW FROM UNIT'S AVAILABLE ESP) | | | | | |
| ALLOWANCE FOR WET COIL: | 0.10 | 0.10 | 0.10 | 0.10 | 0.10 |
| ECONOMIZER (RETURN DUCT): | 0.06 | 0.09 | 0.11 | 0.14 | 0.18 |
| 18kW ELECTRIC HEAT: | 0.31 | 0.43 | 0.56 | 0.71 | 0.87 |
| 36kW ELECTRIC HEAT: | 0.38 | 0.52 | 0.68 | 0.87 | 1.07 |
| 54kW ELECTRIC HEAT: | 0.62 | 0.84 | 1.10 | 1.39 | 1.72 |
| 72kW ELECTRIC HEAT: | 0.68 | 0.93 | 1.21 | 1.54 | 1.90 |
| ADDITIONS: (ADD VALUES BELOW TO UNIT'S AVAILABLE ESP) | | | | | |
| HORIZONTAL (SIDE) SUPPLY DUCT: | 0.31 | 0.26 | 0.27 | 0.31 | 0.41 |
| HORIZONTAL (SIDE) RETURN DUCT: | 0.05 | 0.05 | 0.05 | 0.05 | 0.05 |

TABLE 11 - POWER EXHAUST PERFORMANCE

| MOTOR SPEED | STATIC RESISTANCE OF RETURN DUCTWORK, IWG | | | | | | | | | |
|-------------|---|------|------|------|------|------|------|------|------|------|
| | 0.2 | | 0.3 | | 0.4 | | 0.5 | | 0.6 | |
| | CFM | KW | CFM | KW | CFM | KW | CFM | KW | CFM | KW |
| HIGH* | 5250 | 0.83 | 4500 | 0.85 | 4200 | 0.88 | 3750 | 0.93 | 3000 | 0.99 |
| MEDIUM | 4900 | 0.77 | 3900 | 0.79 | 3500 | 0.82 | 2900 | 0.85 | - | - |
| LOW | 4400 | 0.72 | 3700 | 0.74 | 3000 | 0.78 | - | - | - | - |

*Factory Setting

Power Exhaust motor is a 3/4 HP, PSC type with sleeve bearings, a 48 frame and inherent protection.

TABLE 12 - BLOWER MOTOR AND DRIVE DATA

| MODEL SIZE | DRIVE | BLOWER RANGE (RPM) | MOTOR ¹ | | | ADJUSTABLE MOTOR PULLEY | | | | FIXED BLOWER PULLEY | | | | BELT (NOTCHED) | | QTY. |
|------------|-------------------|--------------------|--------------------|-------|----------|-------------------------|---------------------|------------------|------------|---------------------|--------------------|------------------|------------|----------------|--------------------|------|
| | | | HP | FRAME | EFF. (%) | DESIG-NATION | OUT-SIDE DIA. (IN.) | PITCH DIA. (IN.) | BORE (IN.) | DESIG-NATION | OUTSIDE DIA. (IN.) | PITCH DIA. (IN.) | BORE (IN.) | DESIG-NATION | PITCH LENGTH (IN.) | |
| 25 TON | Standard | 975/1165 | 15 | 254T | 91 | 1LVP58B70A | 7.5 | 6.2-7.4 | 1-5/8 | 1B5V110 | 11.3 | 11.1 | 1-7/16 | 5VX860 | 86.0 | 1 |
| | High Speed Access | 1140/1365 | | | | | | | | 1B5V94 | 9.7 | 9.5 | 1-7/16 | 5VX840 | 84.0 | 1 |

¹All motors have a nominal speed of 1800 RPM, a 1.15 service factor and a solid base. They can operate to the limit of their service factor because they are located in the moving air, upstream of any heating device.

OPERATION

COOLING SYSTEM

The cooling section is a complete factory package utilizing an air-cooled condenser. The system is factory-charged with Refrigerant-22.

The compressors are hermetically sealed, internally sprung and base-mounted with rubber-insulated hold-down bolts.

Compressors have inherent (internal) protection. If there is an abnormal temperature rise in a compressor, the protector will open to shut down the compressor.

PRELIMINARY OPERATION COOLING

After the initial installation, the compressors should be given three false starts (energized just long enough to make a few revolutions) with 5-7 minutes delay between each start, before being put into full time service.

COOLING SEQUENCE OF OPERATION

NO OUTDOOR AIR OPTIONS - When the room thermostat calls for "first-stage" cooling, the low voltage control circuit from "R" to "G" and "Y1" is completed to energize compressors #1/2 (50% capacity), condenser fan motor #1, and the supply air blower motor (if the fan switch on the room thermostat is set in the "AUTO" position).

When the thermostat calls for "second-stage" cooling, the low voltage control circuit from "R" to "Y2" is completed to energize compressor #3/4.

After the thermostat is satisfied and opens, all components will stop simultaneously. The blower motor will continue to operate if the fan switch on the room thermostat is set in the "ON" position.

ECONOMIZER WITH SINGLE ENTHALPY SENSOR - When the room thermostat calls for "first-stage" cooling, the low voltage control circuit from "R" to "G" and "Y1" is completed. The "R" to "G" circuit energizes the blower motor (if the fan switch on the room thermostat is set in the "AUTO" position) and drives the economizer dampers from fully closed to their minimum position. If the enthalpy of the outdoor air is below the setpoint of the enthalpy controller (previously determined), "Y1" energizes the economizer. The dampers will modulate to maintain a constant supply air temperature as monitored by the discharge air sensor. If the outdoor air enthalpy is above the setpoint, "Y1" energizes compressors #1/2, and condenser fan motor #1.

When the thermostat calls for "second-stage" cooling, the low voltage control circuit from "R" to "Y2" is completed. If the enthalpy of the outdoor air is below the setpoint of the enthalpy controller (i.e. first stage has energized the economizer), "Y2" will energize compressors #1/2. If the outdoor air is above the setpoint, "Y2" will energize compressor #3/4.

After the thermostat is satisfied and opens, all components will stop simultaneously. The blower motor will continue to operate if the fan switch on the room thermostat is set in the "ON" position.

ECONOMIZER WITH DUAL ENTHALPY SENSORS - The operation with the dual enthalpy sensors is identical to the single sensor except that a second enthalpy sensor is mounted in the return air. This return air sensor allows the economizer to choose between outdoor air and return air, whichever has the lowest enthalpy value, to provide maximum operating efficiency.

ECONOMIZER (SINGLE OR DUAL) WITH POWER EXHAUST - This system operates as specified above with one

addition. The power exhaust motor is energized whenever the economizer is chosen by the enthalpy sensor for first stage cooling, "Y1". As always, the "R" to "G" connection provides minimum position but does not provide power exhaust operation.

MOTORIZED OUTDOOR AIR DAMPERS - This system operation is the same as the units with no outdoor air options with one exception. When the "R" to "G" circuit is complete, the motorized damper drives open to a position set by the damper motor adjustment. When the "R" to "G" circuit is opened, the damper spring returns fully closed.

CONTINUOUS BLOWER - Continuous blower operation is possible by closing the R to G circuit on the thermostat.

SAFETY CONTROLS

Each refrigerant system is equipped with the following safety controls:

1. A Suction Line Freezestat to protect against low evaporator temperatures due to a low air flow or a low return air temperature. (Opens at 26°F ± 5°F and resets at 38°F ± 5°F)
2. A High Pressure Cutout Switch to protect against excessive discharge pressures due to a blocked condenser coil or a condenser motor failure. (Opens at 380 psig ± 10 and resets at 300 psig ± 10)
3. A Low Pressure Switch/Loss Of Charge to protect against loss of refrigerant charge. (Opens at 7 psig ± 3 and resets at 22 psig ± 5)

If either one of the above safety controls opens, that individual refrigerant system will be locked out. The other refrigerant system will continue in operation unless it too is effected by the same fault. The lock out of either system can be reset by opening the 24V circuit either at the room thermostat or at the unit disconnect.

ELECTRIC HEATING - SEQUENCE OF OPERATION

WITH POWER TO UNIT AND THERMOSTAT IN THE HEATING MODE

Single-stage heating: (applies only to 18 KW heater, all other heaters MUST use a two-stage thermostat:)

- a) If the fan switch is in the "ON" position, the evaporator blower motor contactor (3M) will be energized through terminal G to provide continuous blower operation. If the fan switch is in the "AUTO" position, the blower will operate only when there is a call for heating by the thermostat.

NOTE: All 240 & 480V heaters are provided with manual reset backup protection limits. These will de-energize the heaters should the primary limit fail to open or the contactors fail to open in a failure mode.

- b) Upon a call for heat by the thermostat, the heater contactor (6M) will be energized.
- c) The thermostat will cycle the electric heat to satisfy the heating requirements of the conditioned space.

Two-stage heating: (applies to all heaters except 18 KW):

- a) If the fan switch is in the "ON" position, the evaporator blower motor contactor (3M) will be energized through terminal G to provide continuous blower operation. If the fan

switch is in the "AUTO" position, the blower will operate only when there is a call for heating by the thermostat.

- b) Upon a call for first-stage heat by the thermostat, the heater contactor (6M) (6M & 7M on 72 KW, 240V) will be energized.

If the second stage of heat is required, heater contactor (7M) will be energized. Note that on the 54 KW, 240V heater, heater contactors (7M & 8M) will be energized and on the 72 KW, 240V heater, heater contactors (8M & 9M)

TABLE 9 - HEAT ANTICIPATOR SETTING

| HEATER KW | VOLTAGE | SETTING, AMPS | |
|-----------|--------------|---------------|------|
| | | TH1 | TH2 |
| 18 | 208/230-3-60 | 0.29 | - |
| 36 | | 0.29 | 0.29 |
| 54 | | 0.29 | 0.58 |
| 72 | | 0.58 | 0.58 |
| 18 | 460-3-60 | 0.29 | - |
| 36 | | 0.29 | 0.29 |
| 54 | | 0.29 | 0.29 |
| 72 | | 0.29 | 0.29 |
| 18 | 575-3-60 | 0.29 | - |
| 36 | | 0.29 | 0.29 |
| 54 | | 0.29 | 0.29 |
| 72 | | 0.29 | 0.29 |

will be energized.

- c) The thermostat will cycle the electric heat to satisfy the heating requirements of the conditioned space.

HEAT ANTICIPATOR SETPOINTS

It is important that the anticipator setpoint be correct. Too high of a setting will result in longer heat cycles and a greater temperature swing in the conditioned space. Reducing the value below the correct setpoint will give shorter "ON" cycles and may result in the lowering of the temperature within the conditioned space. Refer to the Heat Anticipator Setpoints table for the required .

GAS HEATING SEQUENCE OF OPERATION

The following sequence describes the operation of the gas heat section.

CONTINUOUS BLOWER

With the room thermostat switch set to "ON", the supply air blower will operate continuously. The normally closed contact "K5-1" provides 24 volt power to the "3M" contactor. The "3M-1, 2 & 3" power contacts close and the blower motor operates.

INTERMITTENT BLOWER

With the room thermostat system switch set to the "AUTO" or "HEAT" position and the fan switch set to "AUTO", the supply air blower will operate after the room thermostat calls for heat and the time delay relay closes.

The "TH1" closes, the heat relay "RW1" is energized. The "RW1-1" power contact closes energizing the line voltage draft motor. The "RW1-2" contact is also closed. As the speed of the draft motor reaches approximately 2500 RPM, the centrifugal switch contact located on the end of the draft motor shaft closes to power the first stage ignition module "IC1".

After a brief pre-purge time, ignition module "IC1" will start the first stage ignitor sparking and will open the redundant valve located inside the first stage main gas valve "GV1" to allow a flow of gas to only the first stage carryover tube. Only after the pilot flame has been ignited and the presence of pilot flame detected at the "IC1" by a signal sent back through the flame sensor is sparking terminated and the first stage main gas valve opened.

Gas flows into each of the main burners and is ignited from the carryover tube flame.

If "IC1" fails to detect a pilot flame, it will continue to try for a maximum of 85 seconds to ignite the pilot tube. If the pilot flame is not detected, then "IC1" will lock out furnace operation for 5 minutes, then retry ignition sequence.

At the same time power was supplied to the "RW1", a parallel circuit activates "ETD" which closes the "ETD" contact after approximately 35 seconds and energizes "K5" which closes "K5-2" and starts the blower by energizing "3M".

When "TH2" closes, heat relay "RW2" is energized. The "RW2-1" contact is closed energizing the second stage ignition module "IC2". "IC2" will immediately start the second stage ignitor sparking and will open the redundant valve located inside the second stage main gas valve "GV2" to allow a flow of gas to the second stage carryover tube. Only after the pilot flame has been ignited and the presence of pilot flame detected at "IC2" by a signal sent back through the flame sensor is sparking terminated and the main gas valve opened.

Gas flows into each of the second stage main burners and is ignited from the carryover tube flame.

If "IC2" fails to detect a pilot flame, it will continue to try for a maximum of 85 seconds to ignite the pilot tube. If the pilot flame is not detected, then "IC2" will lock out furnace operation for 5 minutes, then retry ignition sequence. *Note that the second stage furnace can operate even if first stage has locked out.*

When the heating cycle is complete, "TH2" opens de-energizing the "RW2" then "TH1" opens de-energizing "RW1" and "ETD",

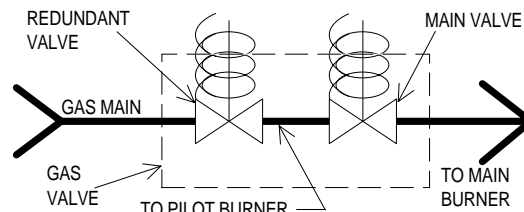

FIG. 12 - GAS VALVE PIPING

thus closing all gas valves. The blower motor will continue to run (approximately 45 seconds after the furnace is shut down) until "ETD" opens, de-energizing the "K5" relay and "3M" contactor. The draft motor will continue to run for a brief post-purge cycle.

SAFETY CONTROLS

The control circuit includes the following safety controls:

1. **Limit Control (LS).** This control is located inside the heat exchanger compartment and is set to open at the temperature indicated in the Limit Control Setting Table. It resets automatically. The limit switch operates when a high temperature condition, caused by inadequate supply air flow occurs, thus shutting down the ignition control and closing the main gas valves and energizing the blower.
2. **Centrifugal Switch (CS).** If the draft motor should fail, the centrifugal switch attached to the shaft of the motor prevents the ignition controls and gas valves from being energized.
3. **Redundant Gas Valve.** There are two separate gas valves in the furnace. Each valve contains a main and a redundant valve. The redundant valves are located upstream of the main gas valves. Should either or both of the main gas valves fail in the open position the redundant valves serve as back-ups and shuts off the flow of gas.
4. **Flame Sensor Rod / 100% Ignition Control Lock-Out.** If an ignition control fails to detect a signal from the flame sensor indicating the pilot flame is properly ignited, then the main gas valve will not open. It will continue to try and ignite the pilot for a maximum of 85 seconds, then if the pilot flame is not detected, the ignition control will lock out furnace operation until 24V power is removed from the module either at the unit or by resetting the room thermostat.
5. **Rollout Switch.** This switch is located above the main burners in the control compartment which in the event of a sustained main burner rollout shuts off and locks out both ignition controls closing both gas valves. The ignition controls lock out furnace operation until 24V power is removed from the controls either at the unit or by resetting the room thermostat. *Note the auto reset rollout switch must reset before allowing furnace operation.*

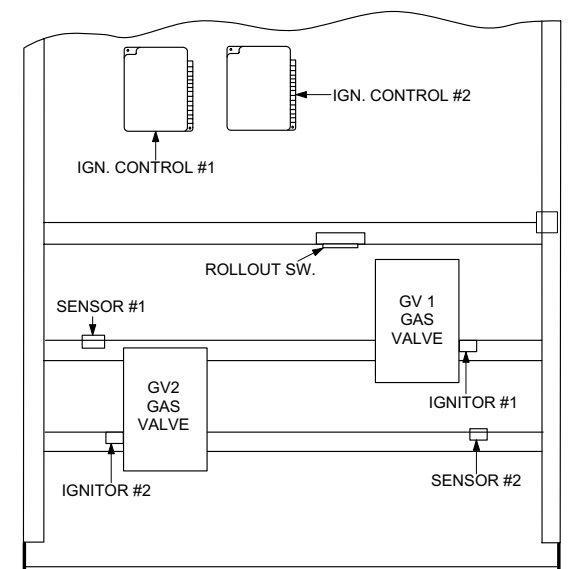

BURNER COMPARTMENT

FIG 13-GAS VALVE AND CONTROLS

TABLE 10 - LIMIT CONTROL SETTING

| Capacity, MBH | | Limit Control Opens, °F |
|---------------|--------|----------------------------|
| Input | Output | |
| 300 | 240 | 195 |
| 400 | 320 | 195 |

HEAT ANTICIPATOR SETPOINTS

It is important that the anticipator setpoint be correct. Too high of a setting will result in longer heat cycles and a greater temperature swing in the conditioned space. Reducing the value below the correct setpoint will give shorter "ON" cycles and may result in the lowering of the temperature within the conditioned space.

| Gas Valve | Anticipator Setpoint | |
|---------------------|----------------------|-----------|
| | 1st Stage | 2nd Stage |
| Honeywell VR8440 | 0.30 amp | 0.11 amp |
| White-Rodgers 36C68 | | |

PRE-START CHECK LIST

Complete the following checks before starting the unit.

1. Check the type of gas being supplied. Be sure that it is the same as listed on the unit nameplate.
2. Make sure that the vent and combustion air hoods have been properly installed.

START-UP

6. **Auxiliary Limit Switch (AUX)** This control is located inside the heat exchanger compartment and is set to open at 190°F. It is a manual reset switch. If AUX limit trips, then the primary limit has not functioned correctly., Replace the primary limit

OPERATING INSTRUCTIONS

CAUTION: This furnace is equipped with an intermittent pilot and automatic re-ignition system. DO NOT attempt to manually light the pilot.

TO LIGHT PILOT AND MAIN BURNERS:

1. Turn "off" electric power to unit.
2. Turn room thermostat to lowest setting.
3. Turn gas valve knob to "on" position.
4. Turn "on" electric power to unit.
5. Set room thermostat to desired temperature. (If thermostat "set" temperature is above room temperature, pilot burner ignition will occur and, after an interval to prove pilot flame, main burners will ignite).

TO SHUT DOWN:

1. Turn "off" electric power to unit.
2. Depress knob of gas valve while turning to "off" position.

POST-START CHECK LIST (GAS)

After the entire control circuit has been energized and the heating section is operating, make the following checks:

1. Check for gas leaks in the unit piping as well as the supply piping.

2. Check for correct manifold gas pressures. See "Checking Gas Input".
3. Check the supply gas pressure. It must be within the limits shown on rating nameplate. Supply pressure should be checked with all gas appliances in the building at full fire. At no time should the standby gas line pressure exceed 13", nor the operating pressure drop below 5.0" for natural gas units. If gas pressure is outside these limits, contact the

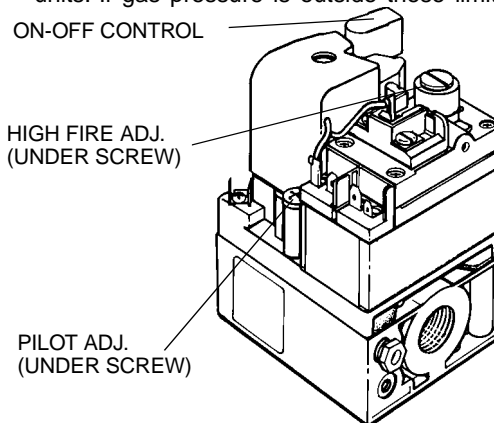

FIG. 14 - TYPICAL GAS VALVE

local gas utility for corrective action.

MANIFOLD GAS PRESSURE ADJUSTMENT

Small adjustments to the high-fire gas flow may be made by turning the pressure regulator adjusting screw on the automatic gas valve. Refer to figure below.

Adjust as follows:

1. Remove the cap on the regulator. It's located next to the push-on electrical terminals.
2. To decrease the gas pressure, turn the adjusting screw *counterclockwise*.

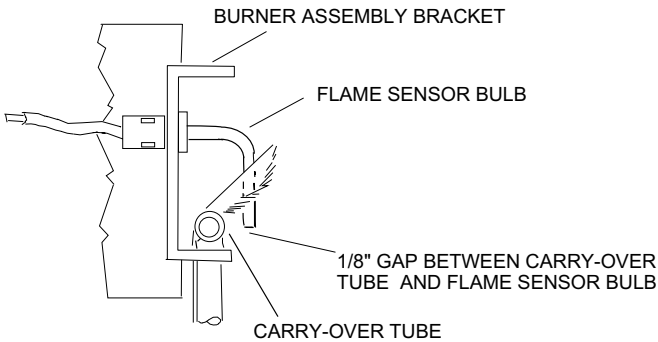

FIG. 15 - PROPER FLAME ADJUSTMENT

- To increase the gas pressure, turn the adjusting screw clockwise.

NOTE: The correct manifold pressure for these furnaces is 3.65 IWG \pm 0.3.

PILOT CHECKOUT

The pilot flame should envelope the end of the flame sensor. Refer to Proper Flame Adjustment figure. To adjust pilot flame, (1) remove pilot adjustment cover screw, (2) increase or decrease the clearance for air to the desired level, (3) be sure to replace cover screw after adjustment to prevent possible gas leakage.

Put the system into operation and observe through complete cycle to be sure all controls function properly.

BURNER INSTRUCTIONS

To check or change burners, pilot or orifices, **CLOSE MAIN MANUAL SHUT-OFF VALVE AND SHUT OFF ALL ELECTRIC POWER TO THE UNIT.**

- Remove the screws holding either end of the manifold to the burner supports.
- Open the union fitting in the gas supply line just upstream of the unit gas valve and downstream from the main manual shut-off valve.
- Remove the gas piping closure panel.
- Disconnect wiring to the gas valves and spark ignitors. Remove the manifold-burner gas valve assembly by lifting up and pulling back.

Burners are now accessible for service.

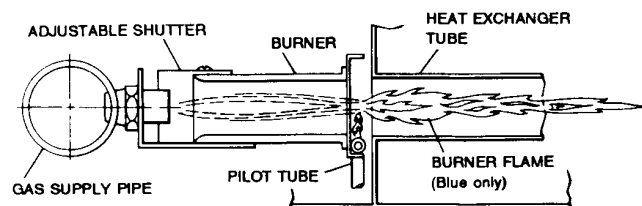

FIG. 16 - TYPICAL FLAME APPEARANCE

Reverse the above procedure to replace the assemblies. Make sure that burners are level and seat at the rear of the heat exchanger.

BURNER AIR SHUTTER ADJUSTMENT

Adjust burner shutters so no yellow flame is observed in the heat exchanger tubes.

CHECKING SUPPLY AIR CFM

The RPM of the supply air blower will depend on the required CFM, the unit accessories or options and the static resistances of both the supply and the return air duct systems. With this information, the RPM for the supply air blower and the motor pulley adjustment (turns open) can be determined from the Blower Performance Data Table.

A high speed drive accessory 1LD0435 (containing a smaller blower pulley and shorter belts) is available for applications requiring the supply air blower to produce higher CFM's and/or higher static pressures. Refer to the Blower Motor and Drive Data Table.

Note the following:

CAUTION

Procedure for adjusting belt tension:

- Loosen four nuts (top and bottom) (A).
- Adjust by turning (B).
- Never loosen nuts (C).
- Use a belt tension checker to apply a perpendicular force to one belt at the midpoint of the span as shown. The deflection force should be applied until a specific deflection distance of 4mm (5/32") is obtained. To determine the deflection distance from normal position, use a straight edge from sheave to sheave as a reference line. The recommended deflection force is as follows:

Tension new belts at the max. deflection force recommended for the belt section. Check the belt tension at least two times during the first 24 hours of operation. Any re-tensioning should fall between the min. and max. deflection force values.

- After adjusting, re-tighten nuts (A).

FIG.17 - BELT ADJUSTMENT

- The supply air CFM must be within the limitations shown in Unit Application Data Table.
- Pulleys can be adjusted in half turn increments.
- The tension on the belts should be adjusted as shown in the belt adjustment figure below.

Start the supply air blower motor. Adjust the resistances in both the supply and the return air duct systems to balance the air distribution throughout the conditioned space. The job specifications may require that this balancing be done by someone other than the equipment installer.

To check the supply air CFM after the initial balancing has been completed:

- Remove the two 5/16" dot plugs from the blower motor and the filter access panels.

- Insert at least 8" of 1/4 inch tubing into each of these holes for sufficient penetration into the air flow on both sides of the indoor coil.

NOTE: The tubes must be inserted and held in a position perpendicular to the air flow so that velocity pressure will not affect the static pressure readings.

- Using an inclined manometer, determine the pressure drop across a dry evaporator coil. Since the moisture on an evaporator coil may vary greatly, measuring the pressure drop across a wet coil under field conditions would be inaccurate. To assure a dry coil, the compressors should be deactivated while the test is being run.



Knowing the pressure drop across a dry coil, the actual CFM through the unit and clean 2" filters, can be determined from the curve in the Pressure Drop Verses Supply Air CFM figure.

WARNING: Failure to properly adjust the total system air quan-

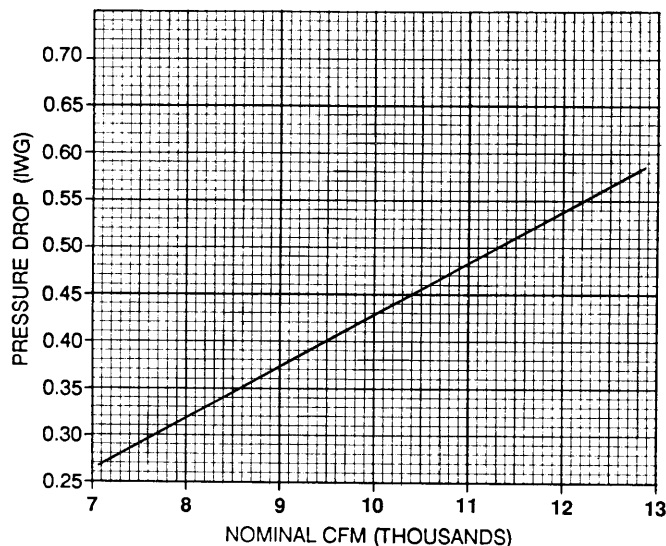

FIG. 18 - PRESSURE DROP ACROSS A DRY INDOOR COIL VS SUPPLY AIR CFM

tity can result in extensive blower damage.

After readings have been obtained, remove the tubes and reinstall the two 5/16" dot plugs that were removed in Step 1.

$$CFM = \frac{Btuh \text{ Input} \times 0.8}{1.08 \times \text{°F Temp. Rise}}$$

NOTE: DE-ENERGIZE THE COMPRESSORS BEFORE TAKING ANY TEST MEASUREMENTS TO ASSURE A DRY INDOOR COIL.

ADJUSTMENT OF TEMPERATURE RISE

The temperature rise (or temperature difference between the return air and the heated air from the furnace) must lie within the range shown on the ETL rating plate.

After the temperature rise has been determined, the cfm can be calculated as follows:

After about 20 minutes of operation, determine the furnace temperature rise. Take readings of both the return air and the heated air in the ducts (about six feet from the furnace) where they will not be affected by radiant heat. Increase the blower cfm to decrease the temperature rise; decrease the blower cfm to increase the rise. Refer to the Blower Motor And Drive Data table.

BELT DRIVE BLOWER

All units have belt drive single-speed blower motors. The variable pitch pulley on the blower motor can be adjusted to obtain the desired supply air CFM. Tighten belts enough to prevent slipping, but do not over tighten. Belt deflection should be between 1/4" and 1/2" per foot. Refer to the table for Blower Motor And Drive Data.

CHECKING GAS INPUT

NATURAL GAS

- Turn off all other gas appliances connected to the gas meter.
- With the furnace turned on, measure the time needed for one revolution of the hand on the smallest dial on the meter. A typical gas meter usually has a 1/2 or a 1 cubic foot test dial.
- Using the number of seconds for each revolution and the size of the test dial increment, find the cubic feet of gas consumed per hour from the Gas Rate Table.

TABLE 11 - GAS RATE - CUBIC FEET PER HOUR

| Seconds for One Rev. | Size of Test Dial | |
|----------------------|-------------------|-----------|
| | 1/2 cu. ft. | 1 cu. ft. |
| 4 | 450 | 900 |
| 6 | 300 | 600 |
| 8 | 228 | 450 |
| 10 | 180 | 360 |
| 12 | 150 | 300 |
| 14 | 129 | 257 |
| 16 | 113 | 225 |
| 18 | 100 | 200 |
| 20 | 90 | 180 |
| 22 | 82 | 164 |
| 24 | 75 | 150 |
| 26 | 69 | 138 |
| 28 | 64 | 129 |

Example: By actual measurement, it takes 13 seconds for the hand on the 1-cubic foot dial to make a revolution with just a 300,000 Btuh furnace running. Read across to the column in the table above, headed "1 Cubic Foot", where you will see that 278 cubic feet of gas per hour are consumed by the furnace at that rate. Multiply 278 x 1050 (the Btu rating of the gas obtained from the local gas company). The result is 292,425 Btuh, which is close to the 300,000 Btuh rating of the furnace.

SECURE OWNER'S APPROVAL: When the system is functioning properly, secure the owner's approval. Show him the location of all disconnect switches and the thermostat. Teach him how to start and stop the unit and how to adjust temperature settings within the limitations of the system.

MAINTENANCE

If the actual input is not within 5% of the furnace rating (with allowance being made for the permissible range of the regulator setting), replace the orifice spuds with spuds of the proper size.

NOTE To find the Btu input, multiply the number of cubic feet of gas consumed per hour by the Btu content of the gas in your particular locality (contact your gas company for this information - it varies widely from city to city.)

NORMAL MAINTENANCE

CAUTION: Prior to any of the following maintenance procedures, shut off all electric power to the unit to prevent personal injury.

Periodic maintenance normally consists of changing or cleaning filters and (under some conditions) cleaning the main burners.

FILTERS - Inspect once a month. Replace disposable or clean permanent type as necessary. DO NOT replace permanent type with disposable. The dimensional size of the replacement filter must be the same as the replaced filter.

MOTORS

Outdoor fan motors are permanently lubricated and require no maintenance.

Ventor motor is factory lubricated for an estimated 10 year life.

Indoor Blower Motor and Drive - The indoor blower motor features ball bearings that do not require periodic lubrication. Periodic lubrication of the motor and bearings can extend the life of components but is optional.

CAUTION: Damage can occur if the bearings are overlubricated. Use grease sparingly.

WARNING: Perform all maintenance operations on the blower motor with electric power disconnected from the unit. Do not attempt to lubricate bearings with the unit in operation.

On an annual basis, check the motor for accumulations of dust, etc. that may block the cooling slots in the motor shell. Check for loose, damaged or misaligned drive components. Check that all mounting bolts are tight. Replace defective parts as required.

If desired, every three years remove both pipe plugs at each end shell and clean out any hardened grease or foreign matter. Replace one plug on each end with a clean grease fitting. Using a low pressure grease gun, pump grease (Chevron SRI-2 or equivalent) into the bearing cavity until new grease shows at the open port. Do not over lubricate. Run the motor for ten minutes until excess grease is purged from the cavity. Replace the plugs.

Units are supplied with blower shaft bearings that do not require maintenance but may be relubricated if desired. Every three years, using a low pressure grease gun, pump grease into the bearing grease fitting until grease just begins to show at the seals. Do not over lubricate. Use any lithium base grease recommended for ball bearing service.

OUTDOOR COIL - Dirt should not be allowed to accumulate on the outdoor coil surface or other parts in the air circuit. Cleaning should be as often as necessary to keep coil clean. Use a brush, vacuum cleaner attachment, or other suitable means. If water is used to clean coil, be sure electric power to the unit is shut off prior to cleaning.

NOTE: Exercise care when cleaning the coil so that the coil fins are not damaged.

Do not permit the hot condenser air discharge to be obstructed by overhanging structures of shrubs.

GAS HEATING UNITS

BURNER & PILOT - Periodically (at least annually at the beginning of each heating season) make a visual check of the pilot and main burner flame. If necessary, adjust main burner primary air shutters to give a distinct, sharp blue flame as explained under "BURNER AIR SHUTTER ADJUSTMENT". If it is not possible to adjust for the proper flame, the burners may need cleaning.

TO CLEAN BURNERS - Remove them from the furnace as explained in "Burner Instructions". Clean burners with hot water applied along top of the burner.

COMBUSTION AIR DISCHARGE - Visually inspect discharge outlet periodically to make sure that the buildup of soot and dirt is not excessive. If necessary, clean to maintain adequate combustion air discharge.

CLEANING FLUE PASSAGES AND HEATING ELEMENTS

With proper combustion adjustment the heating element of a gas fired furnace will seldom need cleaning. If the element should become sooted, it can be cleaned as follows:

1. Remove the burner assembly as outlined in "BURNER INSTRUCTIONS".
2. Remove the roof over the gas heat section.
3. At the top plate from the top draft blower housing and the top draft blower wheel.
4. Remove the screws holding the top of the flue collector box. Carefully remove the top of the flue collector box without ripping the adjacent insulation. Then remove the center divider plate separating the upper and lower flue boxes.
5. On the inside of the flue collector box, remove the flue baffles from the tube interiors. Note the last bend of the baffle fits tightly against the tube forcing the end of the baffle to lock into the tube collar. This collar is formed when the tube is expanded into the end sheet. To remove, move the end of the baffle toward the center of the tube releasing the end of the baffle from the tube collar, then pull straight out of the tube.
6. Using a wire brush on a flexible wand, brush out the inside of each heat exchanger from the burner inlet and flue outlet ends.
7. Brush out the inside of the flue collector box and the flue baffles.
8. Run the wire brush down the vent hoods from the flue collector end.
9. If soot build-up is particularly bad, remove the vent motor and clean the wheel and housings. Run the wire brush down the flue extensions at the outlet of the vent housings.

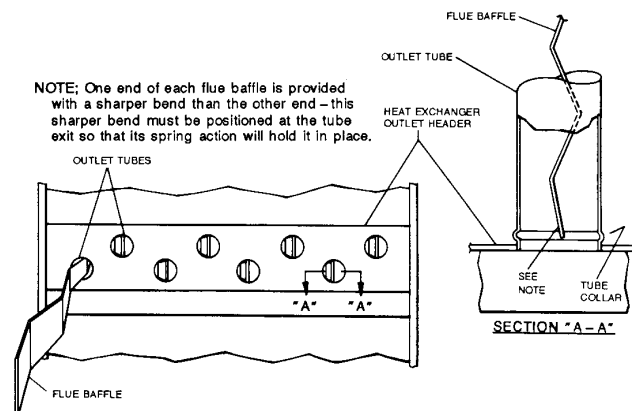

FIG. 19 - TYPICAL FLUE BAFFLE INSTALLATION

TROUBLESHOOTING

10. After brushing is complete, blow all brushed areas with air or nitrogen. Vacuum as needed.
11. Replace parts in the order they were removed in Steps 1 thru 4.
12. When replacing the center and top of the flue collector box, be careful not to tear the adjoining insulation.
13. Ensure that all seams on the vent side of the combustion system are air tight. Apply a high temperature (+500°F) sealing compound where needed.



WARNING: *Troubleshooting of components necessarily requires opening the electrical control box with the power connected to the unit. Use extreme care when working with live circuits! Check the unit nameplate for the correct line voltage and set the volt meter to the correct range before making any connections with line terminals.*



WARNING: *Prior to any of the following maintenance procedures, shut off all electric power to the unit to prevent personal injury.*

CAUTION: *Label all wires prior to disconnection when servicing controls. Wiring errors can cause improper and dangerous operation. Verify proper operation after servicing.*

NOTE: *To find the Btu input, multiply the number of cubic feet of gas consumed per hour by the Btu content of the gas in your particular locality (contact your gas company for this information - it varies widely from city to city.)*

1. The indoor blower motor is a non-inherently protected three-phase motor. Protection is provided by an overload relay for overcurrent and fuses for short circuit. If the motor fails to run, check the line voltage circuit and control voltage circuit per the following procedure:
 - a. If the Indoor Blower Motor does not operate, check visually that contactor M3 is pulled in. If so, check for line voltage between all three phases at the line terminals of the Blower Overload Relay (BOR). If line voltage is found, check the leads to the blower motor for open circuit. If line voltage is found at the motor leads (inside the conduit box on the motor shell), disconnect the motor and check for open windings per the motor wiring diagram. If open windings are found, replace the motor. If line voltage is not found at the BOR, trace the leads back to the field supply terminal block, checking for an open circuit or blown fuses.
 - b. If the contactor M3 is not pulled in, check for control voltage (24V) at the M3 coil. If voltage is found, replace the contactor. If control voltage is not found at M3, check for voltage across terminals 95 & 96 of the BOR. If voltage exists, the BOR is open on overload. The BOR should be set to the auto reset position. The BOR must cool down in order to reset. If the BOR will not reset, replace the BOR. If the BOR resets and M3 pulls in, but the indoor blower motor will still not run, refer to para. (a) for troubleshooting the line voltage supply circuit. If control voltage is not found at the BOR, trace the circuit back to the relay board and thermostat per the unit wiring diagram. Replace any defective components.
 2. Draft motor operates and furnace lights but supply air blower does not start after a short time delay with room thermostat fan switch set to "AUTO".
 - a. Set fan switch to "ON". If blower motor runs, go to Step f. If it does not, check to see if line voltage is being supplied to the contacts of the contactor (M3), and if the contactor is pulled in. Check for loose wiring.
 - b. If contactor (M3) is pulled in, proceed with the troubleshooting steps indicated in Step 1 above.
 - c. If (M3) is pulled in and the blower motor still does not run, replace the blower motor.
 - d. If (M3) is not pulled in, check for 24 volts at the (M3) coil. If 24 volts is present, replace the (M3) contactor.
 - e. If 24 volts is not present at the (M3) coil, check for loose 24 volt wiring back to the relay board. Check control wiring to the room thermostat. If all is fine, replace the relay board.
 - f. If the blower motor runs with the fan switch in the "ON" position but does not run soon after the furnace has ignited with the fan switch in the "AUTO" position, check for loose 24 volt wiring between the relay board in the main control box, the Mate-N-Lok connector in the partition between the evaporator and gas heat sections and the time delay relay (ETD).
 - g. If all control wiring is fine, check for 24 volts at the relay board. If 24 volts is present, replace the relay board. If 24 volts is not present, replace the (ETD) relay.
- NOTE:** *The furnace may shut itself down on a high temperature condition during the procedure, but this will not effect the test if it is done within 5 minutes of furnace shut-down.*
3. The supply air blower operates but the draft motor does not when the room thermostat is set to call for heat and the fan switch in the "ON" position.
 - a. The draft motor has inherent protection. If the motor shell is hot to the touch, wait for the internal overload to reset.
 - b. If the motor shell is cold with the room thermostat calling for heat, check for line voltage at the motor's Mate-N-Lok connector attached to the evaporator partition. If line voltage is present, replace the draft motor.
 - c. If line voltage is not present, check for line voltage at the heat relay (RW1) contacts in the main control box and check to see if the (RW1) is pulled in.
 - d. If the (RW1) relay is pulled in, check for a loose line voltage connection.
 - e. If the (RW1) relay is not pulled in, check for 24 volts at the (RW1) coil. If 24 volts is present, replace the (RW1) relay. If 24 volts is not present, check for a loose 24 volt connection back to the relay board and check the connections from the room thermostat to the relay board. If all connections are correct, replace the relay board.

Cont'd.

TROUBLESHOOTING - Cont'd.

4. The draft motor runs but the furnace does not light and the sparker does not spark.
 - a. The ignition control (IC1, IC2) may be locked out due to either a flame roll out or 100% shut off. These safety features are described above. If lock-out has occurred, 24V must be removed from the ignition controls. This is done at the unit or by resetting the room thermostat. After resetting 24V, check for proper furnace operation. If lock-out continues to occur, locate the source of the problem and correct.
 - b. Check all 24 volt connections from the relay board to and in the gas heat section. Check low voltage connections to the (ETD) located in the control box.
 - c. If the furnace is hot, it may be out on an over-temperature condition, wait for limit reset.
 - d. If the furnace is cold, check for 24 volts at wire 241 attached to the electronic time delay (ETD) located in the main control box. If 24 volts is not found, replace the ETD.
 - e. With the draft motor running, check for 24 volts at terminal 4 of (RW1-2) and (RW2-1). If 24 volts is not present, the centrifugal switch (CS) has not closed or has gone bad. Check the line voltage to the unit - if it is correct, replace the draft motor. If line voltage is low, call the power company.
 - f. Check for 24V at terminal 2 of (RW1-2 and RW2-1). If 24V is not present, check for 24V at (RW1 and RW2) relay coils. If these relays are pulled in, then check for a loose connection at terminal 2 and terminal 4 of each relay. If no problem is found, then replace (RW1 and/or RW2) as required.
 - g. If 24 volts is present at the ignitor controls, check all control wiring at the ignitor controls and the high tension wire to the ignitors. Check that the ground wires from the ignitor controls, the gas valves and pilot burners are all intact and making good electrical connection. Check to make sure that the ceramic insulator on the pilot ignitors or sensors is not broken or cracked, if all are intact, replace the ignition control IC1 or IC2.
5. The draft motor runs and the sparker sparks at the pilot burner but the pilot does not ignite and a gas odor is not detected at the draft motor outlet.
 - a. Check to make sure gas is being supplied to the unit. Make sure that the gas pressure to the unit is within the proper limits as described in the "POST START CHECK LIST" and that the pilot adjust screw is allowing some flow of gas as described in "PILOT CHECKOUT".
 - b. Check all wiring between the ignitor control and the gas valve. Check to make sure the ground connections are intact.
 - c. If the wiring is intact, check for 24 volts across terminals "PV" and "COMMON" on the ignitor control. If 24 volts is not present, replace the ignitor control.
 - d. If 24 volts is present, remove the pilot burner and remove the pilot orifice from the pilot burner. The orifice is removed in the direction opposite the flow of gas. Inspect the orifice for obstruction. If it is clear, replace the main gas valve.
6. The sparker sparks at the pilot burner but the pilot does not ignite and a gas odor is detected at the draft motor outlet.
 - a. Adjust the pilot adjust screw on the gas valve as described in "PILOT CHECKOUT".
 - b. Check the supply pressure as described in "POST START CHECK LIST". Make adjustments as necessary.
 - c. Check the pilot orifice for obstruction as described in para. 5d. Clean as needed but the problem should not be the gas valve.
7. The pilot burner ignites but the sparker continues to spark and the main burners do not ignite.
 - a. Make the same checks and adjustment as described in para. 6.
 - b. Make sure that the pilot burner is not bent or damaged.
 - c. Make sure that the ground connections at the pilot burner, gas valve and ignitor control are intact. Check the high tension wire for good electrical connection. If all are intact, replace the ignitor module.
8. The pilot burner lights and the spark stops but the main burners do not light.
 - a. Check electrical connections between the ignitor control and the gas valve. If intact, check for 24 volts across terminals "MV" and "COMMON" terminals. If no voltage detected, replace ignitor control. If voltage is present, replace gas valve.
9. Furnace lights with roll-out or one burner has delayed ignition.
 - a. Make sure that the pilot burner is aligned properly with the carryover as described in "PILOT CHECKOUT".
 - b. Make sure that the carryovers on adjoining burners are screwed fast and are level with respect to one another.
10. Main burners light but exhibit erratic flame characteristics.
 - a. Adjust air shutters as described in "BURNER AIR SHUTTER ADJUSTMENT".
 - b. Check the main burner orifices for obstruction and alignment. Removal procedure is described in "BURNER INSTRUCTIONS". Clean or replace burner orifices and burners as needed.

REPLACEMENT PARTS

COMPRESSOR SECTION

- Hermetic compressor
- Compressor mounting

MOTOR SECTION

- Blower motor
- Fan motor
- Venter motor

ELECTRICAL SECTION

- Ignition control
- Relay board
- Contactor
- Circuit breaker
- Temperature controls
- Capacitors
- Relays
- Transformers
- Connectors

GAS HEAT SECTION

- Heat exchanger
- Gas valve
- Pilot
- Flame sensor
- Spark ignitor
- Gas manifold
- Gas burner

AIR MOVING SECTION

- Blower wheel
- Blower wheel housing

REFRIGERANT SECTION

- Evaporator coil
- Evaporator coil header
- Expansion valve assembly
- Condenser coil
- Condenser coil header

FABRICATED PARTS SECTION

- Panels
- Posts
- Covers Drain pans
- Base rails
- Air hoods

MISCELLANEOUS SECTION

- Air inlet hood screen
- Fan guard
- Air filters

TO OBTAIN PARTS INFORMATION: Replacement parts and information from OUR current parts list for this unit are available to your servicing contractor through our local distributor. The name and address of our nearest distributor may be obtained by consulting the Yellow Pages of a local telephone directory.

IMPORTANT: In order to supply the correct part or information from the parts list, our distributor will need to be provided with the complete model number listed on the rating plate located on your unit. See page 2 for Product Nomenclature.

WARNING: IMPROPER INSTALLATION, ADJUSTMENT, SERVICE OR MAINTENANCE CAN CAUSE INJURY OR PROPERTY DAMAGE. CONSULT A QUALIFIED INSTALLER, SERVICE AGENCY OR YOUR LOCAL GAS SUPPLIER FOR INFORMATION OR ASSISTANCE.



Heating and Air Conditioning

Unitary Products Group
5005 York Drive, Norman, Oklahoma 73069
Subject to change without notice. Printed in U.S.A.
Copyright © by York International Corporation 1999. All Rights Reserved.



Proud Sponsor
of the 2000
U.S. Olympic Team

Code: SBY

530.18-N11Y