

User's Manual

SPORT DIGITAL AUDIO PLAYER



Thank you for purchasing our products.
Before using the unit, please read this manual carefully
to obtain the best performance from your unit and
retain it for future reference.

FCC Certification

THIS DEVICE COMPLIES WITH PART 15 OF THE FCC RULES. OPERATION IS SUBJECT TO THE FOLLOWING TWO CONDITIONS:
(1) THIS DEVICE MAY NOT CAUSE HARMFUL INTERFERENCE, AND
(2) THIS DEVICE MUST ACCEPT ANY INTERFERENCE RECEIVED, INCLUDING INTERFERENCE THAT MAY CAUSE UNDESIRE OPERATION.

Note: This equipment has been tested and found to comply with the limits for a Class B digital device, pursuant to Part 15 of the FCC Rules. These limits are designed to provide reasonable protection against harmful interference in a residential installation. This equipment generates, uses, and can radiate radio frequency energy and, if not installed and used in accordance with the instructions, may cause harmful interference to radio communications. However, there is no guarantee that interference will not occur in a particular installation. If this equipment does cause harmful interference to radio or television reception, which can be determined by turning the equipment off and on, the user is encouraged to try to correct the interference by one or more of the following measures:

- Reorient or relocate the receiving antenna.
- Increase the separation between the equipment and receiver.
- Connect the equipment into an outlet that is on a circuit different from the one the receiver is connected.
- Consult the dealer or an experienced radio/TV technician for help.

Note: The manufacturer is not responsible for any radio or TV interference caused by unauthorized modifications to this equipment. Such modifications could void the user's authority to operate the equipment.

TABLE OF CONTENTS

WARNING & CAUTIONS	1
NAMES OF EACH PART	2
MAIN UNIT.....	2
FUNCTION OF CONTROLS.....	2
USE OF THE BATTERY	4
USING THE SPORT STRAP	5
GETTING STARTED	7
POWER ON/OFF.....	7
LOCKING THE BUTTONS (HOLD).....	7
MP3/WMA PLAYBACK	8
TO PAUSE PLAYBACK.....	8
TO SEARCH A TRACK.....	9
FAST FORWARD/BACKWARD.....	9
ID3 TAG DISPLAY.....	9
TO SELECT PLAYBACK MODE.....	9
TO STOP PLAYBACK.....	9
MENU FUNCTION	9
FOLDER ROOT.....	10
AUTO PLAY.....	11
EQ MODES.....	11
REPEAT MODES.....	11
-NORMAL.....	11
-RPT 1 (<i>Repeat one</i>).....	12

-RPT ALL (<i>Repeat all</i>).....	12
-RANDOM.....	12
-INTRO.....	12
MEMORY USAGE.....	13
DELETE ALL FILE.....	13
FORMAT	14
ABOUT.....	14
EXIT.....	14
DELETE ONE.....	15
USB DRIVER INSTALLATION (for Win.98 & Win 98SE only).....	16
USE IN PC.....	19
TROUBLE SHOOTING GUIDE.....	21
SPECIFICATIONS.....	22

Important Note:

DRM-Digital Rights Management is used to protect legal music downloads. You can play WMA/WMA-DRM files if you are trying to play music from your own original CD collection on the player. To do this simply rip your CDs in windows media player. Use Windows Media player and select "copy from CD" or "RIP" and then select OPTIONS, and select copy protection or the copy music tab (if you are using Windows media player v.9). Visit online help at www.18002526123.com/findit/Troubleshooting.htm #mp3 to get more information.

WARNING & CAUTIONS

WARNING: TO PREVENT FIRE OR SHOCK HAZARD, DO NOT EXPOSE THE UNIT TO RAIN OR MOISTURE. TO AVOID ELECTRICAL SHOCK, DO NOT OPEN THE CABINET. REFER SERVICING TO QUALIFIED PERSONNEL ONLY.

Cautions

- All the safety and operating instructions should be read before the appliance is operated.
- Do not expose the product to direct sunlight or any source of heat for a long period.
- Should the unit become deformed or malfunction due to exposure to smoke or heat, remove the battery away.
- Do not apply excessive force to LCD screen.
- Do not pull the accessory wires (earphone & USB cable) with excessive force.
- Do not use the built-in USB cable and supplied USB cable synchronously.
- The appliance should not be used near water - for example, near a bathtub, washbowl, kitchen sink, laundry tub, in a wet basement, or near a swimming pool, etc.
- Do not use volatile chemicals on this unit. Clean by lightly wiping with a soft cloth.
- Do not attempt to service the appliance. Refer servicing to qualified personnel.
- For easy continuous playback of all music files, it is recommended that all music files be stored under the main root directory.

NAMES OF EACH PART

Main Unit

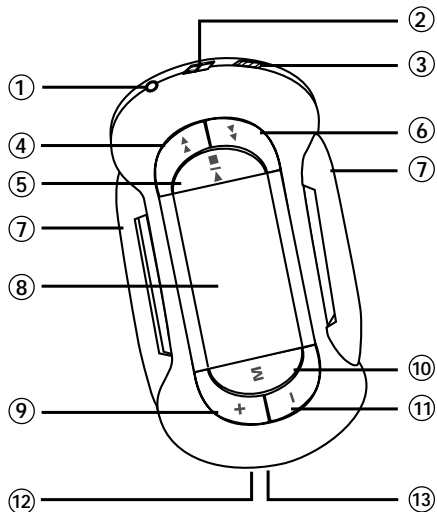

Function of Controls

- ① **PHONES Jack**
For connecting the headphones/earphones.
- ② **BUCKLE**
For buckling the supplied strip.

- ③ **HOLD Knob**
To lock the buttons.
- ④ **▶▶ F.F Button**
Press "▶▶" lightly/repeatedly:
To locate the beginning of the next tracks.
Keep "▶▶" depressed:
To go ahead at high speed.
- ⑤ **▶/■ PLAY/STOP Button**
Press "▶/■" button to begin playing.
Press "▶/■" button to pause play.
Press "▶/■" button to stop during play.
- ⑥ **◀◀ REW Button**
Press "◀◀" lightly/repeatedly:
To locate the beginning of the current track or previous tracks.
Keep "◀◀" depressed:
To go back at high speed.
- ⑦ **STRAP BRACKET**
For holding the unit with the supplied sport strap.
- ⑧ **LCD Display**
To display current status.
- ⑨ **VOLUME + Button**
To increase the volume.
- ⑩ **MENU Button**
Press MENU button to select various modes.
- ⑪ **VOLUME - Button**
To decrease the volume.
- ⑫ **MINI USB Port**
For connecting to your PC with supplied USB cable.
- ⑬ **Built-in USB Plug**
Open the battery cover and take it out.

USE OF THE BATTERY

Insert Battery

Open the rear cover and insert one "UM-4/AAA/1.5V" size battery according to the correct polarity inside the battery compartment.

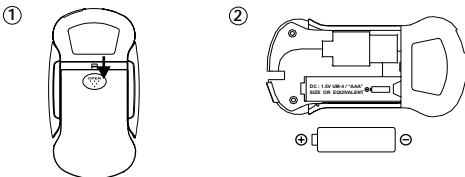

1. Push **OPEN** knob to slide out battery cover.
2. Insert one battery according to the polarity.



Notes on battery

- Insert battery observing the correct polarity.
- If the electrolyte inside the battery should leak, wipe the contaminated parts in the battery compartment with a cloth and replace the old battery with a new one.
- When the unit is not to be used for a long period of time, remove the battery.

Notes on " "

- Insert a new battery, and "  " appears on the display.
- When the battery voltage level is low, "  " will appear on the display, playback still continues for several minutes.
- Playback will automatically come to a stop when the battery has no more power. Replace the battery with a new one.
- Recommend normal alkaline battery be replaced around 7-8 hours.

Remark:

- Do not connect the unit to a computer when battery is low.
- USB will not recharge a regular battery. The unit can operate without battery if connect directly to computer by USB.

USING THE SPORT STRAP

This section mainly explains how to use the sport strap. If necessary, you may hold the unit with the supplied sport strap as follows:

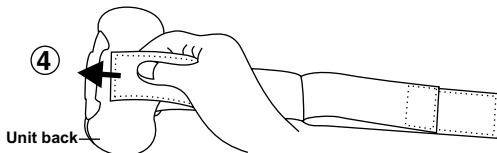
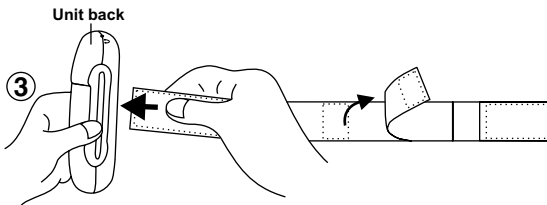
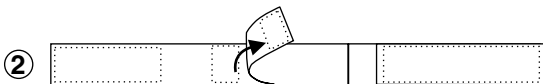

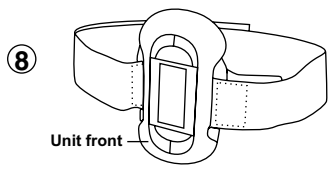
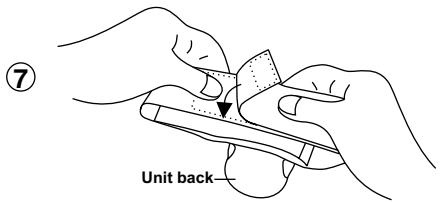
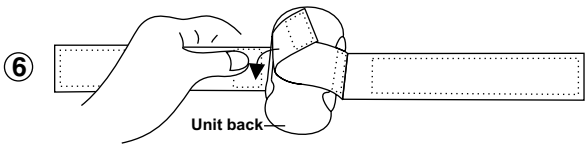
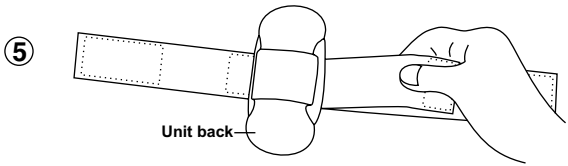

GETTING STARTED

Power On / Off

1. Press "▶/■" button to turn on MP3 player.

The total memory and free memory will appear on the display (for example, 256Mb—Memory Display is subject to the unit your purchased <128Mb/256Mb/512Mb>), and then the MP3 player will turn to standby mode.

- The total tracks of the root folder appear on the display (such as, "01" shows the first track, "30" shows the total tracks of the root folder).
2. Press and hold "▶/■" button more than 2 seconds until the message "POWER OFF" appears on the display to turn the unit off.
 - In standby mode, the unit will automatically shut down after approx 1 minute if no button is pressed.

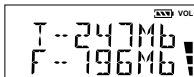

Locking the Buttons (Hold)

HOLD function is used for preventing wrong operation during playback.

- To lock all function buttons by sliding HOLD knob to right, and the "🔒" icon will appear on the display. Then all function buttons can't be operated.

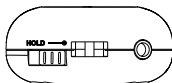

To lock all function buttons

Lock

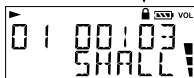

- To release all function buttons by sliding HOLD knob to left, and the "  " icon will disappear on the display.

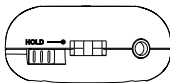



To unlock all function buttons

Unlock



MP3/WMA PLAYBACK



- Press **VOLUME** "+" or "-" button to adjust the volume while playing.
- You may select different music mode by pressing "M" button during playback, and the "EQ" icon and music mode will appear on the display. (**NORMAL - ROCK - LIVE - CLASSIC - POP**)

1. Press "  " button to turn on MP3 player and it will turn to standby mode.
2. Press "  " button again to play the tracks of the current folder.

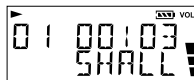
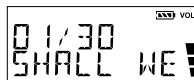
- The MP3/WMA files are played once from beginning to end in current folder.



To Pause Playback

- Press "  " button to pause play.
- Press "  " button again to resume play.

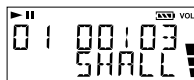

Note: The unit will return to full stop mode automatically after approximately 1 minute if no button is pressed (in pause mode).

To Search a Track

- During playback, you can search a track in current folder.
1. Press "◀" or "▶" button to search a track. Each press skips one track.
 2. It will start to play automatically after searching a desired track.

Fast Forward / Backward

- Press and hold "▶" button will go fast forward during playback.
- Press and hold "◀" button will go fast backward during playback.

ID3 TAG Display

- During playback or pause, File Name and File type will be scrolled from right to left.

To Select Playback Mode

- During playback, you may set up the playback mode by pressing and holding "M" button more than 2 seconds.
- Each time the "M" button is pressed and held, the playback mode will be changed to the next one as follows:
RPT 1 (Repeat one) -> RPT ALL (Repeat all) -> RANDOM -> INTRO
-> NORMAL

To Stop Playback

- Press and hold "▶/■" button more than 2 seconds to stop play and return to the standby mode.



MENU FUNCTION

In standby or pause mode, each time the "M" button is pressed, the mode will be changed to the next one as follows:

FOLDER ROOT -> AUTO PLAY -> EQ_MODE -> RPT_MODE ->
MEMORY USAGE -> DELETE ALL FILE -> FORMAT -> ABOUT ->
EXIT

Folder Root

In standby or pause mode, press "M" button until "FOLDER ROOT" appears on the display. Then press "▶/■" button to enter the folder root. (You may download multi-folders or cascade folders from your PC.)

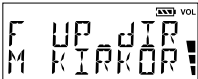
1. In "FOLDER ROOT" mode, press "▶/■" button to enter the root folder. The first two folders appear on the display (such as "0001" and "0002"), and the first folder name scrolls from right to left. ("F" shows the folder.)
2. Press "-" button to select the next folder or other tracks, and the next folder or track name appear on the display. (There must be at least 2 folders in the unit. "M" shows the track, and the following display is the track name and file type.)
3. Press "▶/■" button to enter the folder you selected (or play the track you selected).
4. The "F UP_DIR" appears on the display.
 - Press "-" button to select the next folder or tracks.
 - Or select "F UP_DIR" and press "▶/■" button to return to previous folder cascade.

Note: After entering per folder, please hold "M" button to turn to the standby mode of the current folder.

Remark: For easy continuous playback of all music files, it is recommended that all music files be stored under the main root directory.

Auto Play

In standby or pause mode, press " **M** " button until the " **AUTOPLAY** " appears on the display, and press " + " or " - " button to select ON / OFF, then press " ►/■ " button to confirm.

- AUTOPLAY ON - Playing all tracks of the cascade folders.
- AUTOPLAY OFF - Playing the tracks of the folder you selected.

Notes:

- In AUTOPLAY ON mode, all tracks of all folders appear on the display.
- In AUTOPLAY OFF mode, all tracks of root folder appear on the display. (If there is not any tracks in the root folder, the "00/00 NO FILE" will appear on the display.)

EQ Modes

In standby or pause mode, press " **M** " button until the "EQ_MODE" appear on the display, then press " + " or " - " button to select different music mode, and it will be changed to the next one as follows: NORMAL, ROCK, LIVE, CLASSIC or POP.

- During playback, each time the " **M** " button is pressed, the music mode will be changed to next one.
- The **EQ** icon will disappear on the display when you select the Normal mode.

Repeat Modes

In standby or pause mode, press " **M** " button until the "RPT_MODE" appears on the display. Press " + " or " - " button to select RPT 1, RPT ALL, RANDOM, INTRO or NORMAL, and then press " ►/■ " button to confirm.

- During playback, each time the " **M** " button is held down for 2 seconds, the repeat mode will be changed to next one.

Normal

The MP3 will be played with normal sequence after choosing NORMAL mode.

RPT 1 (Repeat one)

1. Press "+" or "-" button in RPT_MODE until "RPT 1" appears on the display.
 2. Press "▶/■" button once to confirm.
 3. Press "▶/■" button again to start play.
- To select the desired track to be played repeatedly by pressing "▶▶" or "◀◀" button.

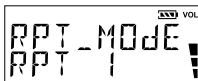

RPT ALL (Repeat all)

1. Press "+" or "-" button in RPT_MODE until "RPT ALL" appears on the display.
 2. Press "▶/■" button once to confirm.
 3. Press "▶/■" button again to start play.
- All tracks will be played repeatedly.



RANDOM - Playing the Selections in Random Order

1. Press "+" or "-" button in RPT_MODE until "RANDOM" appears on the display.
 2. Press "▶/■" button once to confirm.
 3. Press "▶/■" button again to start RANDOM play (All tracks will be played without sequence automatically).
- Press "◀◀" or "▶▶" button to locate the previous or next track.



INTRO - Playing the First Ten Seconds of Each Track

1. Press "+" or "-" button in RPT_MODE until "INTRO" appears on the display.
2. Press "▶/■" button once to confirm.

3. Press "▶/■" button again to start INTRO play (play each track for approx 10 seconds).
- INTRO play always starts from the track that immediately follows the current running one.
 - Press "◀" or "▶" to start intro play from the selected track.



Memory Usage

In standby or pause mode, press "M" button until **MEMORY USAGE** appears on the display. Then press "▶/■" button to check the memory size of the unit.

- The total memory and free memory appear on the display (for example, 256Mb—Memory Display is subject to the unit your purchased <128Mb/256Mb/512Mb>).

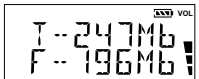

Delete All Files

In standby or pause mode, press "M" button until the "DELETE ALL FILE" appears on the display. Then press "▶/■" button to delete all tracks of the current folder (The folder name can not be deleted).

- All tracks of the current folder will be deleted if you press "▶/■" button when "IF YES, PLAY KEY" appears on the display.
- If all files of the current folder are deleted, the message "NO FILE" will appear on the display.



- Press "M" button to return to current folder (such as Folder 0001), then press "▶/■" button to enter and select the "F UP_DIR" to return to previous folder.
- If all tracks are deleted of the root folder, the message "NO FILE" will always appear on the display when you turn on the unit each time.
- Press "M" button to return to "FOLDER ROOT" mode, and then press "▶/■" button to enter and select other folders.

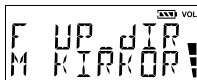
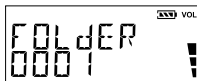

Format

In standby or pause mode, press "M" button until "FORMAT NAND MEM" appears on the display. Then press "▶/■" button to format the MP3 player.



- The MP3 player will be formatted if you press "▶/■" button when "IF YES, PLAY KEY" appears on the display.
- After format, all files and folders will disappear.

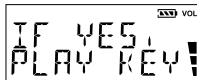

About

In standby or pause mode, press "M" button until "ABOUT" appears on the display, and press "▶/■" button to enter and the number of the version will appear on the display. Then press "▶/■" button to exit.

Exit

In standby or pause mode, press "M" button until "EXIT" appears on the display. Then press "▶/■" button to exit menu function.

Delete One

In standby mode, press and hold "M" button to delete the track you want to delete of the current folder.

1. In AUTOPLAY OFF mode, delete a track of the different folder.

- In standby/pause mode, press "M" button until "FOLDER ROOT" appears on the display.
- Press "▶/■" button to enter root folder.
- Press "+/-" button to select other folder and press "▶/■" button to enter.
- Press and hold "M" button to enter the standby mode and the total tracks of the current folder appears on the display.
- press "◀◀" or "▶▶" button to select the track you want to delete.
- Press and hold "M" button until "DELETE YES, PLAY" appears on the display.
- Press "▶/■" button to confirm and "Wait..." will appear on the display. (Press "M" button to exit if you don't want to delete.)

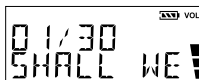
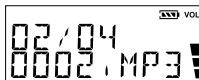

2. In AUTOPLAY ON mode, delete a track of the different folder.

- Turn on the unit and the number of total tracks will appear on the display.
- press "◀◀" or "▶▶" button to select the track you want to delete.
- Press and hold "M" button until "DELETE YES, PLAY" appears on the display.
- Press "▶/■" button to confirm and "Wait..." will appear on the display.

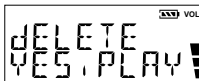

USB DRIVER INSTALLATION (for Win.98 & Win.98SE only)

Windows Me, Windows 2000 and Windows XP have the program to support USB 1.1 Storage Device, and No Driver is required for them. The OS will detect the Audio Player automatically after the connection with the USB port is established.

When connect the unit to your PC (Windows 98 OS) for the first time, the USB mass storage function will not be activated without driver installation. Please use the installation CD-ROM to install the driver and follow the two kinds of installation methods below.

Method One:

1. Insert the installation CD first.
2. Read the readme file of the installation CD.
3. Double Click " install.bat " and Reboot Computer.

Method Two:

1. Insert the installation CD and connect the unit to your PC.
2. If the player is recognized on your PC, the "Add New Hardware Wizard" is activated, and click "Next".



3. Select “Search for the best driver for your device (Recommended)”.
Click “Next”.



4. Select “Specify a location” and click “Next”.



5. USB driver file is found. Click "Next".



6. USB driver installation has been completed, click "Finish" and restart your computer.



USE IN PC

1. Turn on your computer, and connect MP3 Player to USB Port (Do not use the built-in USB cable and supplied USB cable synchronously).
2. The "Removable Disk" appears in "My Computer" (Figure 1). In Windows Me/2000/XP, a new icon appears on the bottom of the desktop (Figure 2).

Figure 1



Figure 2



3. Then you may directly download the MP3 files or other files. The message "DATA_WD" will appear on the MP3 display when download the files.

Notes:

- For easy continuous playback of all music files, it is recommended that all music files be stored under the main root directory.
- The unit can operate without battery if connect directly to computer by USB.

4. After use, if you want to unplug the MP3 Player, please do as below:
Windows 98: You may directly unplug the MP3 Player after the message "DATA_WD" disappears on the display for about 5 seconds. Then "Removable Disk" disappears in "My Computer".

Windows Me/2000/XP(Such as Windows XP):

- ① Move the mouse to the  icon on the bottom of the desktop, and the "Safely Remove Hardware" message appears on the display as below:

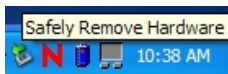

- ② Double click the  icon and a dialog box appears on the display as below:

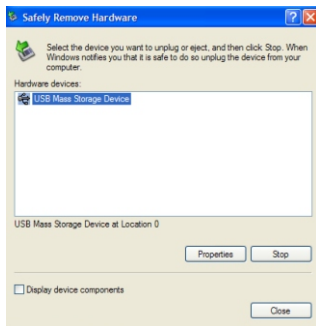

③ Click “Stop” and the next dialog box appears on the display.

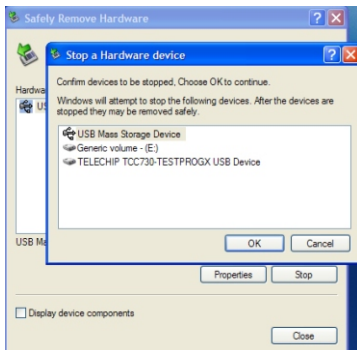

④ Click “OK”, then you can unplug the unit safely.

TROUBLE SHOOTING GUIDE

Should any problem persists after you have made the following checks, consult your nearest service facility.

LCD is blank:

- Weak battery.
Replace the batteries with new one.
- The battery polarity is wrong.
Insert the battery with right polarity.

MP3 play does not start:

- Main unit is locked (HOLD ON mode).
Release the lock mode.
- Weak batteries.
Replace the battery with new one.
- Moisture condensation
Leave the unit in a warm place until the moisture evaporates.

No sound from the headsets:

- The headphones/earphones plug is not firmly connected to the " **PHONES** " jack .
- Adjust the " **VOLUME** " control.
- Dirty plug.

Failed download of a file to the player

- Check the connection between your computer and the player to ensure that the cable is secure.
- Check whether the battery is exhausted.

The OS fails to detect the MP3 Player automatically after the USB Driver installation.

- Check USB Driver installation and ensure it is successful.
- Check the USB control in BIOS and ensure it is enabled.

If you have any questions, please contact dealer or refer servicing to qualified personnel.

SPECIFICATIONS

Item	Specification
Memory	Flash Memory (128Mb/256Mb/512Mb)
MPEG support	MP3, WMA
Supported OS	Win.98, Win.Me, Win.2000 & Win.XP
PC Interface	Standard USB 1.1 (Max 3.5Mbps)
Battery	1 UM-4/AAA/1.5V battery
Maximum Output	2 x 7mW (32 Ω) (Output through Earphone)
S/N Ratio	90dB ("A" filter)
Output Frequency	20Hz-20KHz
USB Interface	Compatible with USB1.1
Dimensions	Approx. 45mm x 19mm x 85mm (W x D x H)
Weight	Approx. 40g (without battery)

Design and specifications are subject to change without notice!

Printed in China
811-333291-040