

Waldorf® 800 SERIES

Installation and Operation Manual

Chargrill

CH8300G

CH8600G

CH8900G

CH8120G

CHL8600G

CHL8900G

CHL8120G



Date Purchased

Serial Number

Dealer

Service Provider

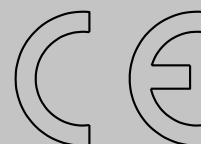

For use in GB & IE

228592-28

MANUFACTURED BY

Moffat Limited
PO Box 10001
Christchurch
New Zealand
Ph: (03) 389 1007
Fax: (03) 389 1276

WORLD-WIDE BRANCHES**UNITED KINGDOM**

Blue Seal
67 Gravelly Business Park
Gravelly Park
Birmingham
West Midlands
B24 8TQ
Ph: (121) 327 5575
Fax: (121) 327 9711

UNITED STATES

Moffat Inc
3765 Champion Blvd
Winston-Salem
North Carolina 27115
Ph: (336) 661 0257
Fax: (336) 661 9546

CANADA

Serve Canada
22 Ashwarren Road
Downview
Ontario M3J1Z5
Toll Free: 800 263 1455
Ph: (416) 631 0601
Fax: (416) 631 0315
info@servecanada.com
www.servecanada.com
www.moffat.com

NEW ZEALAND**Christchurch**

Moffat Limited
PO Box 10-001
16 Osborne Street
Christchurch
Ph: (03) 389 1007
Fax: (03) 389 1276

Auckland

Moffat Limited
4 Waipuna Road
Mt Wellington
Auckland
Ph: (09) 574 3150
Fax: (09) 574 3159

AUSTRALIA**Victoria**

Moffat Pty Limited
740 Springvale Road
Mulgrave, Melbourne
Victoria 3171
Ph: (03) 9518 3888
Fax: (03) 9518 3838

New South Wales

Moffat Pty Limited
3/142 James Ruse Drive, Rose Hill
PO Box 913, Smithfield
Sydney, N.S.W. 2142
Ph: (02) 8833 4111
Fax: (02) 8833 4133

Western Australia

Moffat Pty Limited
67 Howe Street
Osbourne Park
WA 6017
Ph: (08) 9202 6820
Fax: (08) 9202 6836

Queensland

Moffat Pty Limited
30 Prosperity Place
Geebung, Brisbane
Queensland 4034
Ph: (07) 3630 8600
Fax: (07) 3630 8623

The reproduction or copying of any part of this manual by any means whatsoever is strictly forbidden unless authorized previously in writing by the manufacturer.

In line with policy to continually develop and improve its products, Moffat Ltd. reserves the right to change the specifications and design without prior notice.

CH8300G-B	Gas Chargrill, 300mm wide - Bench Model.
CH[1]8600G-[2]	Gas Chargrill, 600mm wide.
CH[1]8900G-[2]	Gas Chargrill, 900mm wide.
CH[1]8120G-[2]	Gas Chargrill, 1200mm wide.

NOTE: [1]: - - Standard Back Models.
L - Low Back Models.
[2]: LS - On Leg Stand.
B - Bench Models

Introduction	2
Specification	3
Model Numbers Covered in this Specification	
General	
Gas Supply Requirements	
Gas Connection	
Dimensions	5
Installation	7
Installation Requirements	
Unpacking	
Location	
Clearances	
Assembly	
Fitting Adjustable Feet / Rear Rollers to Leg Stand Units	
Gas Connection	
Commissioning	
Operation	12
Operation Guide	
Description of Controls	
Lighting the Pilot Burners	
Lighting the Main Burners	
Cleaning and Maintenance	14
General	
After Each Use	
Daily Cleaning	
Weekly Cleaning	
Periodic Maintenance	
Fault Finding	17
Gas Conversion and Specifications	18
Conversion Procedure	
Gas Specifications	
Replacement Parts List	25

Introduction

We are confident that you will be delighted with your WALDORF CHARGRILL, and it will become a most valued appliance in your commercial kitchen.

To ensure you receive the utmost benefit from your new Waldorf CHARGRILL, there are two important things you can do.

Firstly:

Please read the instruction book carefully and follow the directions given. The time taken will be well spent.

Secondly:

If you are unsure of any aspect of the installation, instructions or performance of your appliance, contact your WALDORF dealer promptly. In many cases a phone call could answer your question.

CE Only:

These instructions are only valid if the country code appears on the appliance. If the code does not appear on the appliance, refer to the supplier of this appliance to obtain the technical instructions for adapting the appliance to the conditions for use in that country.

WARNING:

IMPROPER INSTALLATION, ADJUSTMENT, ALTERATION, SERVICE OR MAINTENANCE CAN CAUSE PROPERTY DAMAGE, INJURY OR DEATH. READ THE INSTALLATION, OPERATING AND MAINTENANCE INSTRUCTIONS THOROUGHLY BEFORE INSTALLING OR SERVICING THIS APPLIANCE.

WARNING:

INSTRUCTIONS TO BE FOLLOWED IN THE EVENT THE USER SMELLS GAS ARE TO BE POSTED IN A PROMINENT LOCATION. THIS INFORMATION SHALL BE OBTAINED BY CONSULTING THE LOCAL GAS SUPPLIER.

WARNING:

GREAT CARE MUST BE TAKEN BY THE OPERATOR TO USE THE EQUIPMENT SAFELY TO GUARD IT AGAINST RISK OF FIRE.

- THE APPLIANCE MUST **NOT** BE LEFT ON UNATTENDED.
- IT IS RECOMMENDED THAT A REGULAR INSPECTION IS MADE BY A COMPETENT SERVICE PERSON TO ENSURE CORRECT AND SAFE OPERATION OF YOUR APPLIANCE IS MAINTAINED.
- **DO NOT** STORE OR USE GASOLINE OR OTHER FLAMMABLE VAPOURS OR LIQUIDS IN THE VICINITY OF THIS OR ANY OTHER APPLIANCE.
- **DO NOT** SPRAY AEROSOLS IN THE VICINITY OF THIS APPLIANCE WHILE IT IS IN OPERATION.

CAUTION:

This appliance is;

- For professional use and is to be used by qualified persons only.
- Only qualified service persons are to carry out installation, servicing and gas conversion operations.
- Components having adjustments protected (e.g. paint sealed) by the manufacturer should not be adjusted by the user / operator.
- **DO NOT** operate the appliance without the legs supplied fitted.

Specifications

CH8300G-B	Gas Chargrill, 300mm wide - Bench Model.
CH[1]8600G-[2]	Gas Chargrill, 600mm wide.
CH[1]8900G-[2]	Gas Chargrill, 900mm wide.
CH[1]8120G-[2]	Gas Chargrill, 1200mm wide.

NOTE: [1]: - Standard Back Models.
L - Low Back Models.
[2]: LS - On Leg Stand.
B - Bench Models

General

A commercial heavy duty, fully modular, gas fired chargrill created for modular kitchens and can be supplied in 4 different sizes with branding grates or optional griddle plates. Fitted with 300mm section stainless steel burners. Individual 'Hi'-'Lo' gas control to each burner and is fitted with piezo ignited permanent pilot and flame failure protection for each chargrill burner.

Gas Supply Requirements

- Australia /New Zealand Only:

	Natural Gas				LP Gas (Propane)			
	CH8300G	CH8600G	CH8900G	CH8120G	CH8300G	CH8600G	CH8900G	CH8120G
Input Rating (N.H.G.C.)	33.0 MJ/hr	66.0 MJ/hr	100.0 MJ/hr	133 MJ/hr	33.0 MJ/hr	66.0 MJ/hr	100.0 MJ/hr	133 MJ/hr
	31,270 Btu/hr	62,500 Btu/hr	94,700 Btu/hr	126,000 Btu/hr	31,270 Btu/hr	62,500 Btu/hr	94,700 Btu/hr	126,000 Btu/hr
Supply Pressure	1.13 - 3.40 kPa (4.5" - 13.5" w.c.)				2.75 - 4.50 kPa (11" - 18.0" w.c.)			
Burner Operating Pressure	1.0 kPa (*)	0.95 kPa (*)			2.5 kPa (*)	2.6 kPa (*)		
	(4" w.g.)	(3.8" w.g.)			(9.8" w.g.)	(10.0" w.g.)		
Gas Connection	1/2" BSP Male	3/4" BSP Male			1/2" BSP Male	3/4" BSP Male		

- UK Only:

		Natural Gas (G20)				Propane (G31)			
		CH8300G	CH8600G	CH8900G	CH8120G	CH8300G	CH8600G	CH8900G	CH8120G
Heat Input (nett)	Nominal	8.8 kW	18.0 kW	27.0 kW	36.0 kW	8.8 kW	18.0 kW	27.0 kW	36.0 kW
	Reduced	3.5 kW	6.0 kW	9.0 kW	18.0 kW	3.7 kW	6.4 kW	9.6 kW	12.8 kW
Gas Rate (nett)	Nominal	0.93 m ³ /hr	1.90 m ³ /hr	2.86 m ³ /hr	3.81 m ³ /hr	0.68 kg/hr	1.40 kg/hr	2.10 kg/hr	2.80 kg/hr
	Reduced	0.37 m ³ /hr	0.63 m ³ /hr	0.95 m ³ /hr	1.27 m ³ /hr	0.29 kg/hr	0.50 kg/hr	0.75 kg/hr	0.99 kg/hr
Supply Pressure		20 mbar				37 mbar			
Burner Operating Pressure		10.6 mbar (*)	10 mbar (*)			25 mbar (*)	26 mbar (*)		
Gas Connection		1/2" BSP Male	3/4" BSP Male			1/2" BSP Male	3/4" BSP Male		

* - The chargrill burner operating pressure is to be measured at the manifold test point with one burner for CH8300G model or two burners for other models operating at full setting. The operating pressure is ex-factory set and not to be adjusted, apart from when converting between gases, if required. (Refer to the 'Gas Conversion' section for details).

Specifications

Gas Connection

Bench Models (CH8300G Model Only)

Gas supply connection point is located at the rear of the appliance, approximately 100mm from the left hand side, 23mm from the rear and 39mm from the floor and is reached from the rear of the appliance. (Refer to the 'Dimensions' section).

Connection is ½" BSP male (For G592 model).

Bench Models (CH8600G / CH8900G / CH8120G Models Only)

Gas supply connection point is located at the rear of the appliance, approximately 216mm from the left hand side, 31mm from the rear and 55mm from the floor and is reached from the rear of the appliance. (Refer to the 'Dimensions' section).

Connection is ¾" BSP male (For all other models).

Leg Stand Models (CH8600G / CH8900G / CH8120G Models Only)

Gas supply connection point is located at the rear of the appliance, approximately 216mm from the left hand side, 31mm from the rear and 553mm from the floor and is reached from beneath the appliance. (Refer to the 'Dimensions' section).

Connection is ¾" BSP male (For all other models).

Dimensions

CH8300G-B NOTE: CH8300G are only available in Bench Model (- B) Option.

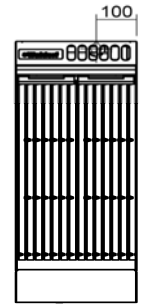
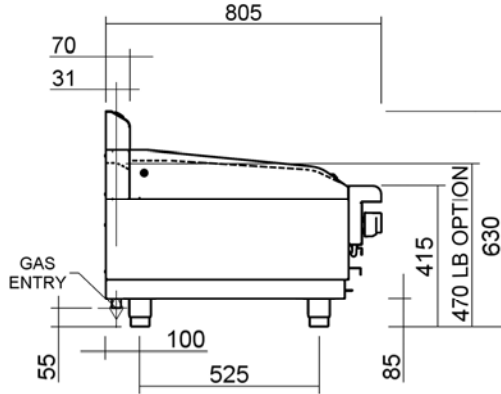
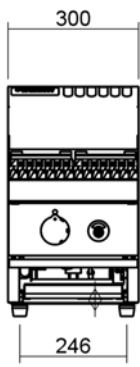

CH8600G-B

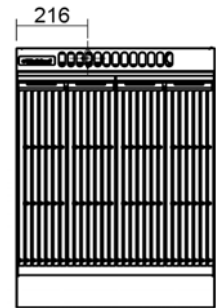
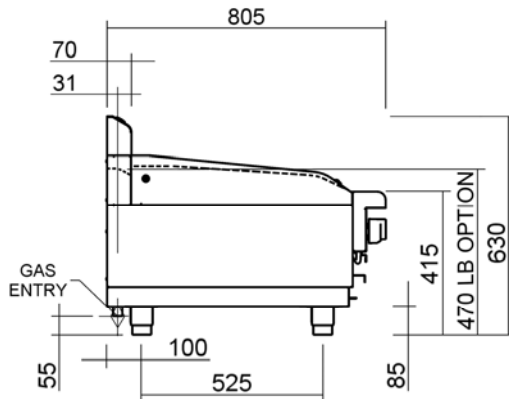
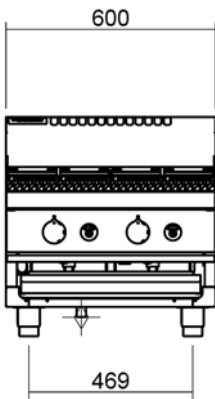

CH8900G-B

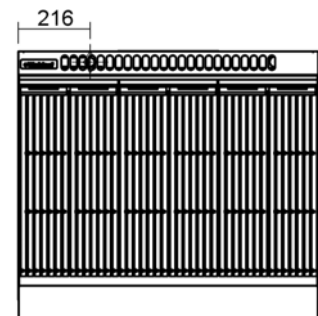
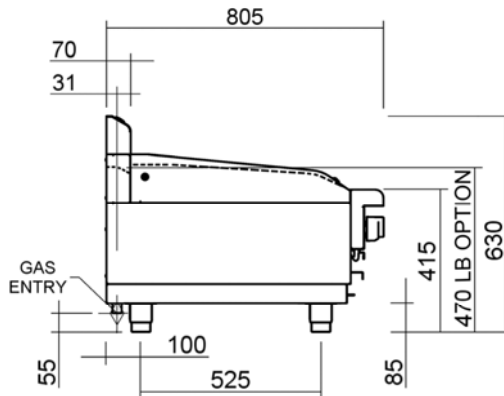
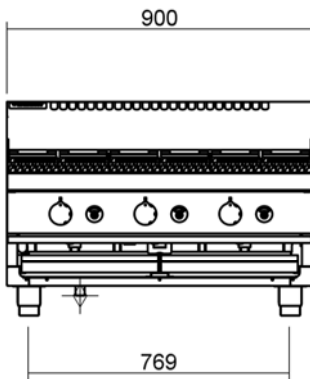

CH8120G-B

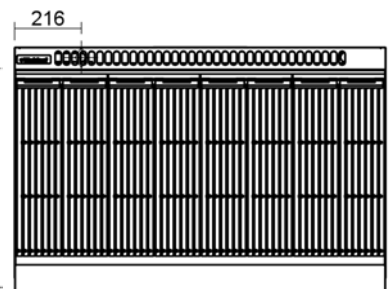
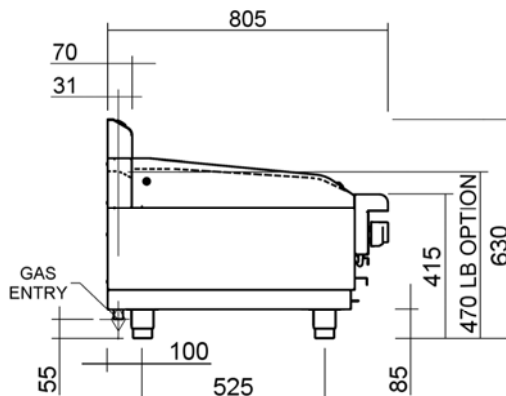
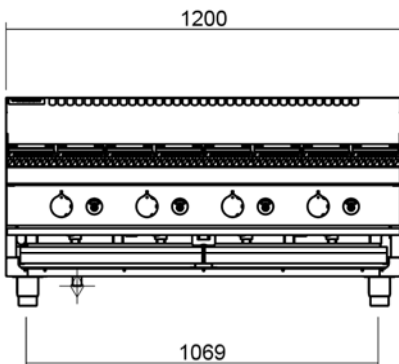

Dimensions

CH8600G-LS

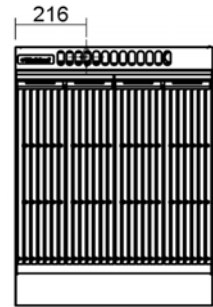
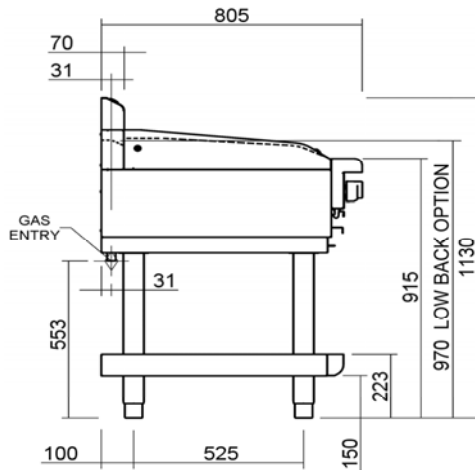
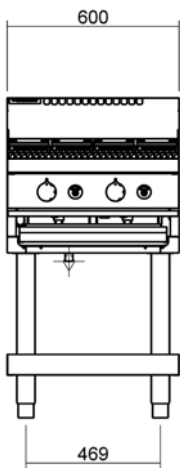

CH8900G-LS

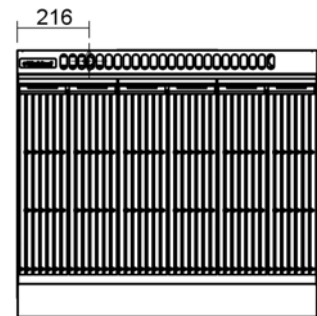
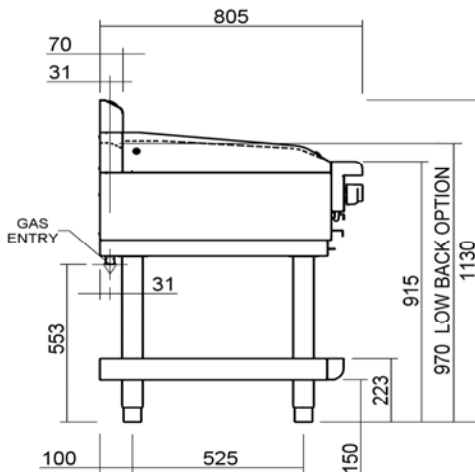
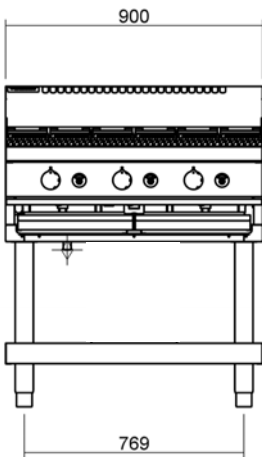

CH8120G-LS

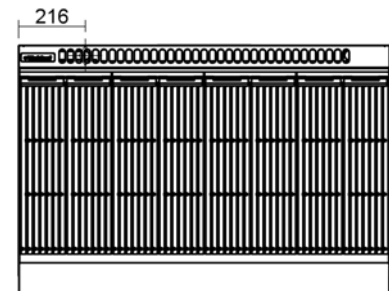
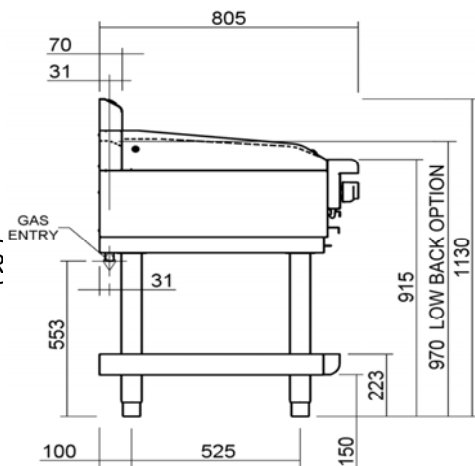
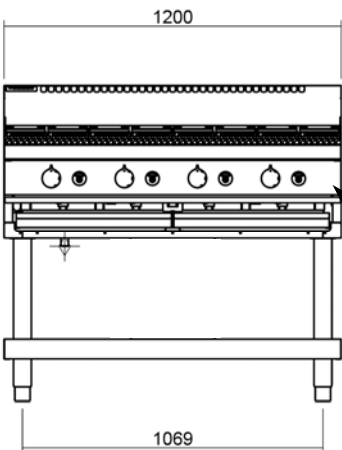

(R) = Rating Plate Location for this option.

Installation Requirements

NOTE:

- It is most important that this appliance is installed correctly and that operation is correct before use. Installation shall comply with local electrical, gas, health and safety requirements.
- This appliance shall be installed with sufficient ventilation to prevent the occurrence of unacceptable concentrations of health harmful substances in the room, the appliance is installed in.

Waldorf charrills are designed to provide years of satisfactory service, and correct installation is essential to achieve the best performance, efficiency and trouble-free operation.

This appliance must be installed in accordance with National Installation Codes and in addition, in accordance with relevant National / Local Codes covering gas and fire safety.

Australia:	- AS5601	- Gas Installations.
New Zealand:	- NZS5261	- Gas Installation.
United Kingdom:	- Gas Safety (Installation & Use) Regulations 1998.	
	- BS6173	- Installation of Catering Appliances.
	- BS5440	- 1 & 2 Installation Flueing & Ventilation.
Ireland:	- IS 820	- Non - Domestic Gas Installations.

Installations must be carried out by qualified persons only. Failure to install equipment to the relevant codes and manufacturer's specifications shown in this section will void the warranty. Components having adjustments protected (e.g. paint sealed) by manufacturer are only allowed to be adjusted by an authorised service agent. They are not to be adjusted by the installation person.

Unpacking

- Remove all packaging.
- Check equipment and parts for damage. Report any damage immediately to the carrier and distributor.
- Remove protective plastic coating from the side panels.
- Check that the following parts have been supplied with the charrill:
 - 1 x Gas Regulator.
 - 1 x Gas Type Conversion Kit.
- Report any deficiencies to the distributor who supplied the charrill.
- Check that the available gas supply is correct to that shown on the rating plate attached to the underside of the R/H side, front hob lower trim.

Location

1. Installation must allow for a sufficient flow of fresh air for the combustion air supply.
2. Installation must include adequate ventilation to prevent dangerous build up of combustion products.

Combustion Air Requirements				
	CH8300G	CH8600G	CH8900G	CH8120G
Natural Gas (G20)	9m ³ /hr	18m ³ /hr	27m ³ /hr	36m ³ /hr
LPG/Propane (G31)	9m ³ /hr	18m ³ /hr	26m ³ /hr	35m ³ /hr

3. Never directly connect a ventilation system to the appliance flue outlet.
4. Position the charrill in its approximate working position.

NOTE: Do not obstruct or block the appliances flue. Never directly connect a ventilation system to the appliance flue outlet.

Installation

Clearances

NOTE: Only non-combustible materials can be used in close proximity to this appliance.

	Combustible Surface	Non Combustible Surface
Left / Right hand side	200mm	0mm
Rear	150mm	0mm

Assembly

Bench Models (CH8300G Model Only)

1. Check that all the feet are securely fitted.

Bench Models (CH8600G / CH8900G / CH8120G Models Only)

1. Check that all the feet are securely fitted.
2. Adjust the feet to make the Chargrill steady and level.

Mounting the Chargrill direct onto Bench / Worktop (Non-Combustible materials Only)

NOTE:

- Ensure that the bench / worktop has been suitably modified to accept the gas connection at the rear of the chargrill.
- Ensure that the bench top surface is made of a non-combustible material.

- a. Remove the grates, griddle plates and radians from the chargrill.
- b. Lower the chargrill onto it's rear face.
- c. Remove the legs and leg plates from the underside of the chargrill.
- d. Lift the chargrill back into the upright position and place onto the bench / worktop.
- e. Refit all the grates, griddle plates and radians to the chargrill, ensuring that they are correctly fitted.

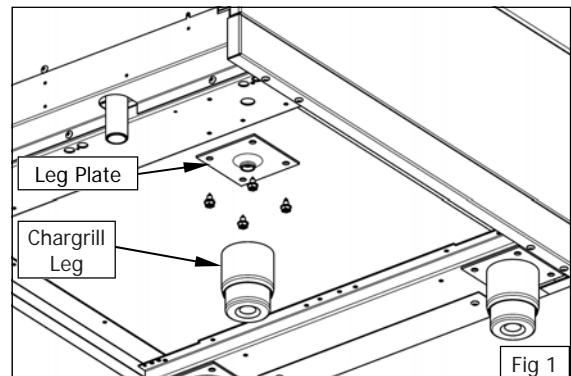

Leg Stand Models Only

- Leg Stand Models will require assembly. Refer to the 'Fitting of Adjustable Feet / Rollers to Leg Stand Units' information below for assembly instructions.
- The rear leg housings can be fitted with:-
 - a. Adjustable feet to assist with levelling of the appliance on uneven floors.
 - b. Rear rollers to enable the appliance to be easily moved for positioning and cleaning purposes.
 - c. The front and rear leg mounting points can be removed for fitting direct onto a bench top work surface etc without legs fitted.

Optional Accessories (Refer to Replacement Parts List)

- Plinth Kit. For installation details, refer to the instructions supplied with each kit.

Fitting of Adjustable Feet / Rear Rollers.

WARNING:

TO PREVENT EQUIPMENT DAMAGE AND RISK OF INJURY, REMOVE ALL CHARGRILL CASTINGS, BURNERS AND OTHER REMOVABLE ITEMS PRIOR TO FITTING THE LEG STAND.

1. Remove the grates, griddle plates and radians from the chargrill.
2. Lower the chargrill onto it's rear face.
3. Attach the four hob legs to the leg mounting positions on the underside of the chargrill. Secure each leg hand tight.
4. Align the four round cut out holes on the base tray with the four hob legs already fitted to the chargrill (Ensure that the base tray is orientated with the sloping edge of the base tray facing the front of the appliance).
5. Slot the base tray onto the four hob legs and push fully home.
6. Secure the base tray to the chargrill legs by screwing the two front adjustable feet supplied, into the base of the front chargrill legs. Secure each adjustable foot, hand tight.
7. The two rear leg housings can be fitted with either adjustable legs or rollers. (See Fig 2).

NOTE:

- This appliance is fitted with adjustable feet to enable the it to be positioned securely and level. This should be carried out on completion of the gas connection. Refer to the 'Gas Connection' section overleaf.
- This appliance can also be fitted with rear rollers to enable the appliance to be easily moved for positioning and cleaning purposes. If desired, these rollers are supplied in the packaging, with the appliance. See overleaf for fitting instructions.

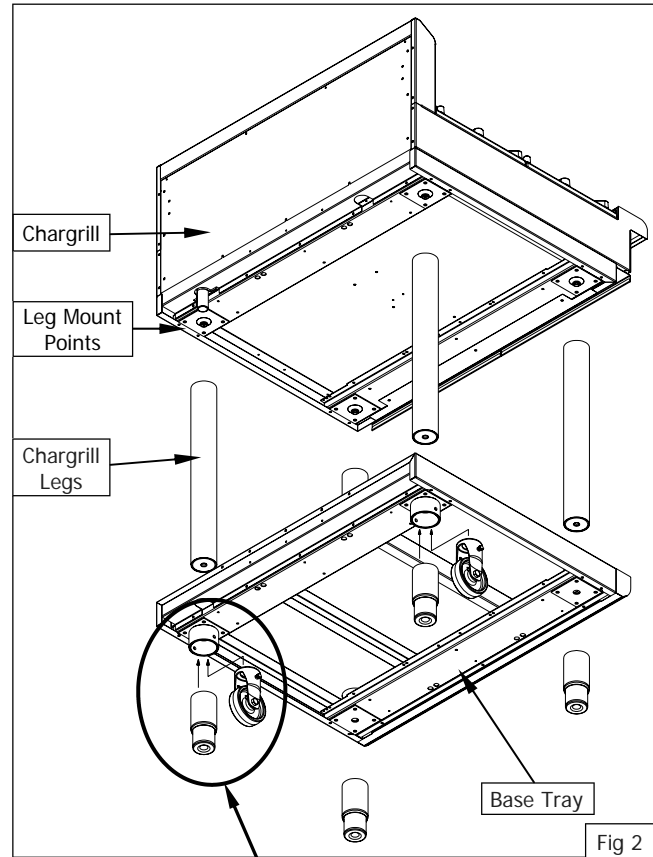

Fig 2

Rear Adjustable Feet, fitting:-

- a. Secure the rear of the base tray to the rear chargrill legs by screwing the two adjustable feet supplied, into the base of the rear chargrill legs.
- b. Secure each adjustable foot, hand tight.

Rear Rollers, fitting:-

- a. Fit the rear leg securing bolts up through the centre of the rear leg housings to secure the rear of the base tray to the rear chargrill legs and tighten up the bolts using a 24mm socket.
- b. Fit the rear rollers to the rear leg supports.
- c. Secure the rear rollers to the rear leg supports using the locating bolts supplied.
- d. Tighten the locating bolts using a 10mm spanner.

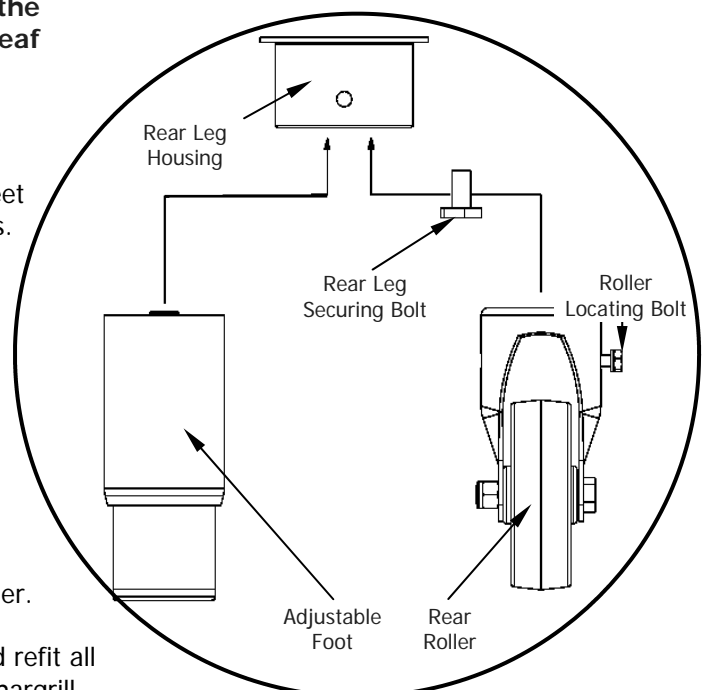

8. Lift the chargrill back onto its legs / rollers and refit all the grates, griddle plates and radians to the chargrill, ensuring that they are correctly fitted.
9. Adjust the adjustable feet to level the appliance.

Installation

Gas Connection

NOTE: ALL GAS FITTING MUST ONLY BE CARRIED OUT BY A QUALIFIED PERSON.

1. Waldorf Chargrills do not require an electrical connection, as they function on the gas supply only.
2. It is essential that the gas supply is correct for the chargrill to be installed and that adequate supply pressure and volume is available. The following checks should be made before installation:
 - a. **The Gas Type** the appliance has been supplied for is shown on coloured stickers located above the gas entry point and next to the rating plate. Check that these are correct for the gas supply the appliance is being installed for. The gas conversion procedure is detailed in the 'Gas Conversion and Specification' section of this manual.
 - b. **The Supply Pressure** required for this appliance is shown in the 'Specifications' section of this manual. Check the gas supply to ensure that adequate supply pressure exists.
 - c. **The Input Rate** of this appliance is shown on the Rating Plate and in the 'Specifications' section of this manual. The input rate should be checked against the available supply line capacity. **Particular note should be taken if the chargrill is being added to an existing installation.**

NOTE: It is important that adequately sized piping runs directly to the connection point on the appliance with as few tees and elbows as possible to give maximum supply volume.

3. Fit the gas regulator supplied, into the gas supply line as close to the appliance as possible.

For CH8300 the regulator connection is ½" BSP female. The connection on the unit is ½" BSP male.

For all other models the regulator connections are ¾" BSP female. The connection on the unit is ¾" BSP male.

(Refer to the 'Specifications' section for the gas supply location dimensions).

NOTE:

The gas pressure regulator provided with this appliance is convertible between Natural Gas and LPG as per the 'Gas Conversion Section' in this manual. Ensure the regulator is converted to the correct gas type that the appliance will operate on. The regulator outlet pressure is fixed ex-factory for the gas type that the regulator is converted to and it is NOT to be adjusted.

4. A suitable joining compound which resists the breakdown action of LPG must be used on every gas line connection, unless compression fittings are used.

NOTE: A manual isolation valve must be fitted to the individual appliance supply line.

5. Correctly locate the appliance into its final operating position and using a spirit level, adjust the legs so that the unit is level and at the correct height.

WARNING:

CHECK CONNECTIONS FOR LEAKS WITH SOAPY WATER. DO NOT USE A NAKED FLAME.

6. Connect the gas supply to the appliance.
7. Check gas operating pressure is as shown in 'Specifications' section.
8. Check all gas connections for leakages using soapy water or other gas detecting equipment.

NOTE: The operating pressure to be measured at the manifold test point and with two burners operating at the 'High Flame' setting. (With the exception of the CH8300G model which has one burner only).

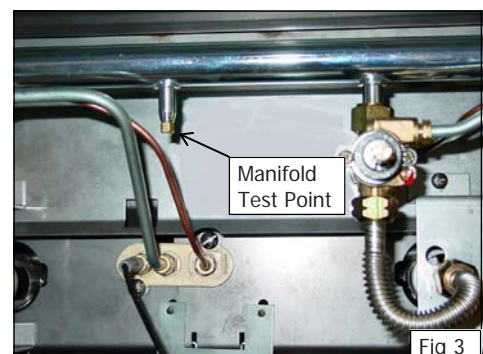

Fig 3

9. Turn off the mains gas supply and bleed the gas out of the appliance gas lines.
10. Turn 'ON' the gas supply and the appliance.
11. Verify the operating pressure remains correct.

Commissioning

1. Before leaving the new installation;
 - a. Check the following functions in accordance with the operating instructions specified in the 'Operation' section of this manual.
 - Light the Pilot Burner.
 - Light the Main Burner.
 - Check the Low Fire Burner Operation.
 - Check the High Fire Burner Operation.
 - b. Ensure that the operator has been instructed in the areas of correct lighting, operation, and shutdown procedure for the appliance.
2. This manual must be kept by the owner for future reference and a record of ***Date of Purchase, Date of Installation*** and ***Serial Number of Unit*** recorded and kept with this manual. **(These details can be found on the rating plate attached to the underside of the R/H side, front hob lower trim. (Refer to the 'Gas Connection' section).**

NOTE: If for some reason it is not possible to get the chargrill to operate correctly, contact the supplier of this appliance.

Operation

Operation Guide

CAUTION:

- This appliance is for professional use and is only to be used by qualified people.
- Only qualified service persons should be used to carry out installation, servicing or gas conversion operations.
- Components having adjustments protected (e.g. paint sealed) by the manufacturer should not be adjusted by the user / operator.

1. Waldorf Chargrills have been designed to provide simplicity of operation and 100% safety protection.
2. Improper operation is therefore almost impossible, however bad operation practices can reduce the life of the chargrill and produce a poor quality product. To use this chargrill correctly please carefully read the following sections.

- Lighting the Pilot Burner.
- Lighting the Main Burner.

Description of Controls



Fig 4



Gas Control Knobs

- OFF Position
- ★ PILOT Burner
- △ HIGH Flame
- △ LOW Flame



Piezo Igniter (with burner flame viewing ports).

Lighting the Pilot Burner

WARNING:

WHEN THE SOLID GRIDDLE PLATE IS USED ON CHARGRILL'S, IT'S SURFACE TEMPERATURE CAN REACH OVER 350°C WHEN THE APPLIANCE IS OPERATED AT FULL SETTING.

NOTE: All chargrill models incorporate the push button piezo ignition system for each individual pilot burner.

1. Depress the gas control knob and rotate anti-clockwise to the 'PILOT' position.
2. With the gas control knob held in the depressed position, depress the piezo igniter button located on the front control panel to the right of the gas control knob, until the pilot burner ignites. (Each depression operation of the piezo igniter button will generate a single spark). Pilot ignition can be viewed through openings in the plastic surround fitted to the piezo igniter button.
3. Hold in the gas control knob for approximately 10-15 seconds, then release. The pilot burner should remain alight. (If not repeat Items 2 and 3 above).

Lighting the Main Burner

1. Turn the gas controls anti-clockwise to first stop ('FULL' flame position) and allow the chargrill to heat up to operating temperature.
2. 'LOW' flame can be achieved by depressing the gas control knob and rotating fully anti-clockwise.
3. For intermediate heat, position the gas control knob between the 'HIGH' and 'LOW' positions to achieve the desired heat.
4. During idle periods, the main burners can be turned down to maintain an appropriate plate temperature or the gas controls can be set to the 'PILOT' position as required.

NOTE:

- Always set the gas control knob to the 'HIGH' position when lighting the main burners.
- If the pilot burner goes out during normal operation, wait 5 minutes before attempting to re-lighting the pilot burner.

IMPORTANT

Should any abnormal operation like;

- ignition problems,
- abnormal burner flame,
- burner control problems,
- partial or full loss of burner flame in normal operation, be noticed, the appliance requires IMMEDIATE service by a qualified service person and should not be used until such service is carried out.

Cleaning and Maintenance

CAUTION:

Always turn off the gas supply before cleaning.
This appliance is not water proof.
Do Not use water jet spray to clean interior or exterior of this appliance.

General

Clean the chargrill regularly. A clean chargrill looks better, will last longer and will perform better. Carbonised grease on the surface or on the chargrill will hinder the transfer of heat from the cooking surface to the food. This will result in loss of cooking efficiency.

NOTE: Each chargrill can be supplied with a chargrill scraper assembly, scraper tool and a pack of blades for cleaning the chargrill surface. These are not supplied with the chargrill but can be purchased separately. Replacement blades and handles can also be purchased separately. Refer to the 'Replacement Parts List' at the rear of the manual.

WARNING:

THE BLADES FITTED TO THE SCRAPER TOOL ARE EXTREMELY SHARP AND ARE TO BE USED WITH CARE.

NEVER use the ribbed scraper blade on the flat surface of the griddle plate.
DO NOT use water on the chargrill while this item is still hot as warping and cracking may occur. Allow the chargrill to cool down before cleaning.

NOTE:

- DO NOT use abrasive detergents, strong solvents or caustic detergents as they could corrode or damage the chargrill.
- In order to prevent rust forming on the chargrill, ensure that any detergent or cleaning material has been completely removed after each cleaning. The appliance should be switched on briefly to ensure the chargrill becomes dry. Oil or grease should be spread over the chargrill cooking surface in order to form a thin protective greasy film.

To keep your chargrill clean and operating at peak efficiency, follow the procedures shown below:-

After Each Use

1. Clean the chargrill with the scraper tools to remove any food debris.

CAUTION:

Always apply even pressure is over the whole surface of the scraper tool when using on the flat surface of the chargrill, griddle plate to prevent scoring of the surface.

NEVER bang the sharp edge of the scraper tool on the flat surface of the griddle plate as this will damage the surface and invalidate the warranty.

2. Always ensure that the scraper tool blades are changed regularly to ensure that the scraper tool works efficiently and prevents damage to the chargrill surface.

Daily Cleaning

1. The crumb tray(s) should be checked and emptied frequently to prevent overflow and spillage. Remove the crumb tray(s) while still warm so that the grease is in a liquid state. Empty any grease from the trays and wash thoroughly in the same manner as any cooking utensil.
2. Remove the grates and radiants and thoroughly clean with the splash back, interior and exterior surfaces of the chargrill with hot water, a detergent solution and a soft scrubbing brush.
3. Brush the chargrill surface with a soft bristled brush. Any carbon deposits should be removed using a scraper tool followed by wiping with a cloth to prevent accumulation of food deposits.
4. Dry the cooking area thoroughly with a dry cloth and polish with a soft dry cloth.

Weekly Cleaning

NOTE:

- If the chargrill usage is very high, we recommend that the weekly cleaning procedure is carried out on a more frequent basis.
- Ensure that protective gloves are worn during the cleaning process.
- DO NOT use harsh abrasive detergents, strong solvents or caustic detergents as they will damage the chargrill and burners.
- DO NOT use water on the griddle plates while they are still hot as warping may occur. Allow these items castings to cool and remove for cleaning.

Grates (Cast Iron)

- a. Clean the grates thoroughly with a wire brush or a flexible spatula.
- b. A scraper tool can be used for the removal of stubborn carbon and deposits.
- c. Clean with hot water, a recommended detergent solution and a scrubbing brush. Dry all components thoroughly with a dry cloth.
- d. The chargrill should be switched on briefly to ensure the grates becomes dry. A thin film of cooking oil should be spread over the grates in order to form a protective film.



Fig 5

Radiants (Cast Iron)

- a. Clean the radiants thoroughly with a wire brush or a flexible spatula.
- b. A scraper tool can be used for the removal of stubborn carbon and deposits.
- c. Clean with hot water, a mild detergent solution and a scrubbing brush. Dry all radiants thoroughly with a dry cloth.



Fig 6

Main Burners

- a. The main burners can be cleaned with hot water, a recommended detergent solution and a scrubbing brush. Ensure that any excess water is removed from inside the burners. Dry all burners thoroughly with a dry cloth.
- b. Ensure that the burners are fitted correctly over the main injectors and are located properly into the recesses in the chargrill.



Fig 7

Stainless Steel Surfaces

- a. Clean the exterior surfaces of the chargrill with hot water, a mild detergent solution and a soft scrubbing brush. Note that the gas control knobs are a push fit onto the gas control valve spindles and can be removed to allow cleaning of the front control panel.
- b. Baked on deposits or discolouration may require a good quality stainless steel cleaner or stainless steel wool. Always apply cleaner when the appliance is cold and rub in the direction of the grain.
- c. To remove any dis-colouration, use an approved stainless steel cleaner or stainless steel wool. Always rub in the direction of the grain.
- d. Remove the grease tray and clean with a mild anti bacterial detergent and hot water solution using a soft bristled brush.
- e. Dry the grease tray thoroughly with a dry cloth.
- f. Dry all components thoroughly with a dry cloth and polish with a soft dry cloth.



Fig 8

Cleaning and Maintenance

Griddle - Steel Plate (Optional Extra)

CAUTION:

Always apply even pressure is over the whole surface of the scraper tool when using on the flat surface of the chargrill, griddle plate to prevent scoring of the surface.

NEVER bang the sharp edge of the scraper tool on the flat surface of the griddle as this will damage the surface and invalidate the warranty.

NOTE: In order to prevent the forming of rust on the griddle plate, ensure that all detergent and cleaning material has been entirely removed after each cleaning process. The appliance should be switched on briefly to ensure the griddle plate becomes dry. Oil or grease should be spread over the griddle surface in order to form a thin protective greasy film.

- a. Remove and clean the grease collection drawer frequently to prevent over spills.
- b. Clean the griddle surface thoroughly with a scraper tool or wire brush. If necessary use a griddle stone or a scotch bright pad on the griddle surface for the removal of stubborn or accumulated carbon deposits..
- c. Occasionally bleach the griddle plate with vinegar when the plate is cold.
- d. Clean with hot water, a mild detergent solution and a scrubbing brush. Dry all components thoroughly with a dry cloth.
- e. The griddle should be switched on briefly to ensure that the griddle plate becomes dry. A thin smear of cooking oil should be spread over the griddle in order to form a protective film.

Periodic Maintenance

NOTE: All maintenance operations should only be carried out by a qualified service person.

To achieve the best results cleaning must be regular and thorough and all controls and mechanical parts checked and adjusted periodically by a competent serviceman. If any small faults occur, have them attended to promptly. Don't wait until they cause a complete breakdown. It is recommended that the appliance is serviced every 6 months.

Gas Control Valve Re-Greasing

The gas control valve should be dismantled and greased every 6 months to ensure the correct operation of the gas control valve.

To carry out this operation;-

- a. Remove the gas control knobs from the gas tap spindles by pulling the knobs away from the control panel.
- b. Remove the drip tray from the appliance.
- c. Remove the two screws on the underside of the control panel, securing the control panel to the hob.
- d. Remove the control panel from the front of the appliance.
- e. Remove the 2 screws holding shaft plate to gas control body and remove control shaft and plate. (See Fig 9). Note orientation of shaft for correct re-assembly.
- f. Using needle nose pliers or similar, pull out gas control spindle, again noting its orientation.
- g. Apply a suitable high temperature gas cock grease or lubricant such as ROCOL - A.S.P (Anti scuffing paste)/ Dry Moly Paste to the outside of spindle. (See Fig 10).
- h. Replace spindle and re-assemble the gas control in reverse order.
- i. Refit the control panel to the appliance and secure with 2 screws.
- j. Refit the knobs to the gas control valve spindles.

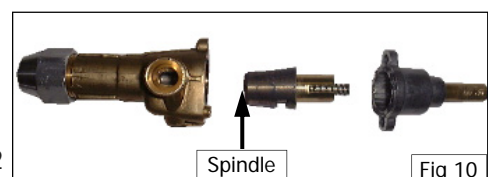
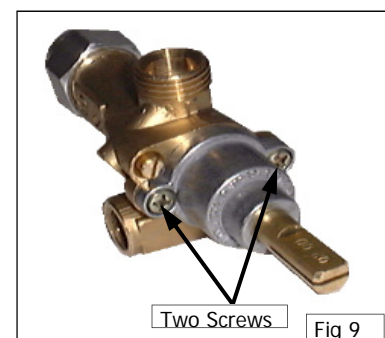

Fault Finding

This section provides an easy reference guide to the more common problems that may occur during the operation of your equipment. The fault finding guide in this section is intended to help you correct, or at least accurately diagnose problems with your equipment.

Although this section covers the most common problems reported, you may encounter a problem not covered in this section. In such instances, please contact your local authorised service agent who will make every effort to help you identify and resolve the problem. Please note that the service agent will require the following information:-

- **The Model Trade Name and the Serial Number of the Appliance. (both can be found on the Technical Data Plate located on the appliance.**

Fault	Possible Cause	Remedy
Pilot won't light.	No gas supply.	Ensure gas isolation valve is turned on, and that bottles are not empty.
	Blocked pilot injector.	Call service provider.
Pilot goes out when gas control knob released.	Releasing knob before the thermocouple has heated.	Hold knob in for at least 20 seconds following ignition of pilot.
	Pilot flame too small. - Gas pressure too low. - Partially blocked pilot injector.	Call service provider.
	Thermocouple faulty.	Call service provider.
Main burner will not light.	Incorrect supply pressure.	Call service provider.
	Faulty gas control.	Call service provider.

NOTE: Components having adjustments protected (e.g. paint sealed) by the manufacturer, are only to be adjusted by an authorised service agent. They are not to be adjusted by an unqualified service person.

Gas Conversion and Specifications

Conversion Procedure

NOTE:

- These conversions should only be carried out by qualified persons. All connections must be checked for leaks before re-commissioning appliance.
- Adjustment of components that have adjustments/settings sealed (e.g. paint sealed) can only be adjusted in accordance with the following instructions and shall be re-sealed before re-commissioning this appliance.
- For all relevant gas specifications refer to the table at the end of this section.

CAUTION:

Ensure that the Unit is isolated from the gas supply before commencing servicing.

CH8600G/CH8900G/CH8120G Models Only

Main Burners

1. Remove the gas control knobs from the front control panel. The control knobs are a push fit onto the shaft of the gas control valves.
2. Remove the front control panel by slackening the 2 screws on the front lower edges of the control panel and remove the panel from the front of the chargrill.
3. Remove the chargrill castings / griddle plates and inner radiants to reveal the burners.
4. Carefully push the main burners forwards and negotiate between the shield brackets fitted over the end of the burners and remove the burners from the chargrill to reveal the main burner injectors.
5. Unscrew the main burner injectors from the chargrill using a 13mm / 1/2" A/F spanner.
6. Determine the correct injector sizes for the corresponding gas, from the rating plate affixed behind the control panel next to the manifold test point.
7. Replace with the correct size injectors.
8. Refit the main burner castings, griddle plates and inner radiants to the chargrill.

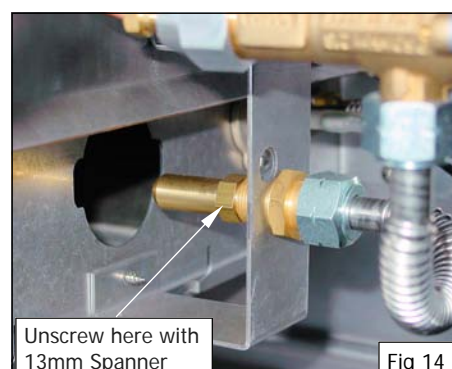
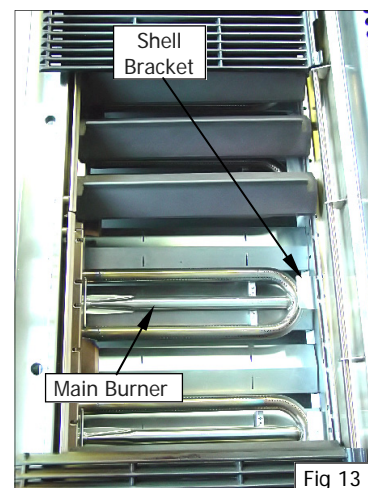
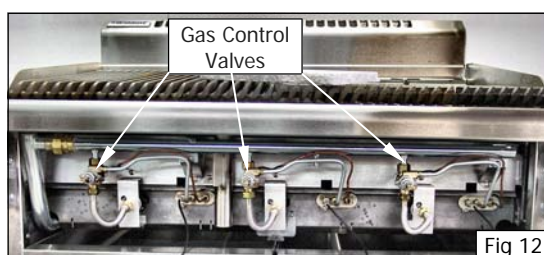
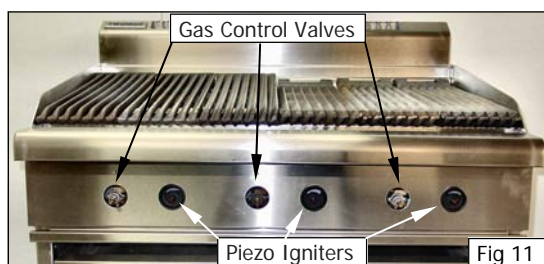

Gas Conversion and Specifications

Pilot Burners

1. To remove the pilot burner, disconnect the gas supply tube from the base of the pilot burner.
2. Using a small screwdriver, withdraw injector from inside the pilot burner.
3. Determine the correct injector size for the corresponding gas from the rating plate attached to the inner bulkhead adjacent to the manifold test point behind the front control panel.
4. Fit the new pilot injector into the rear of the pilot burner and push fully home.
5. Re-connect the gas supply tube to the base of the pilot burner and tighten.

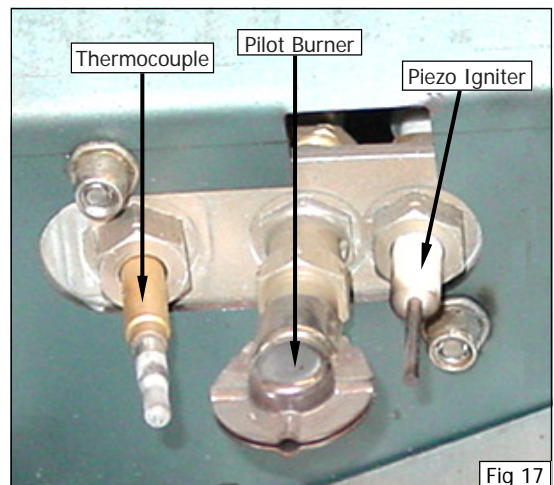
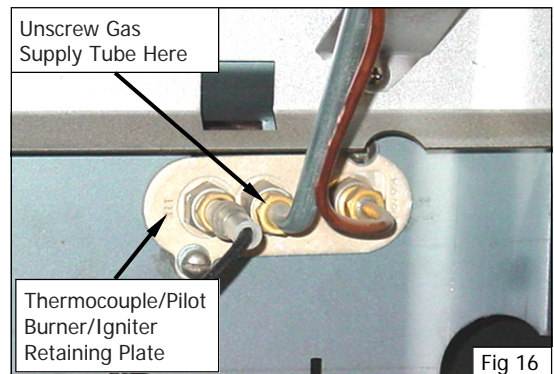
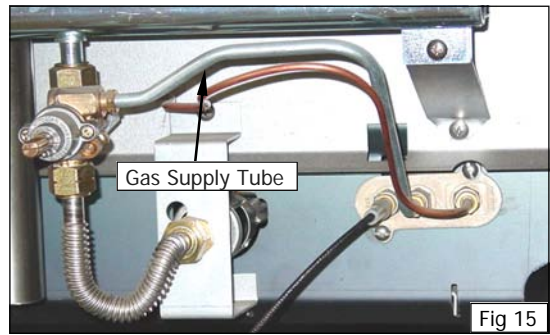

Gas Conversion and Specifications

CH8300G Model Only

Main Burner

1. Remove the gas control knob from the front control panel. The control knob is a push fit onto the shaft of the gas control valve.
2. Remove the front control panel by slackening the 2 x 8mm screws on the front lower edges of the control panel and gently lift off the control panel.
3. Disconnect the cable from the rear of the piezo igniter on the rear of the control panel.
4. Remove the front control panel from the front of the chargrill.
5. Remove the chargrill castings / griddle plates and inner radiants to reveal the burner.
6. Remove the left and right inner heat shield panels (These are a slot fit onto either side of the chargrill).
7. Remove the end heat shield panel. (This is a slot fit onto the front inner face of the chargrill).
8. Carefully push the main burner forwards and remove the burner from the chargrill to reveal the main burner injector.
9. Unscrew the main burner injector from the chargrill using a 13mm / 1/2" A/F spanner.
10. Determine the correct injector size for the corresponding gas, from the rating plate affixed behind the control panel next to the manifold test point.
11. Replace with the correct size injectors.
12. Check / adjust the main burner aeration gap. This gap should be fully open.

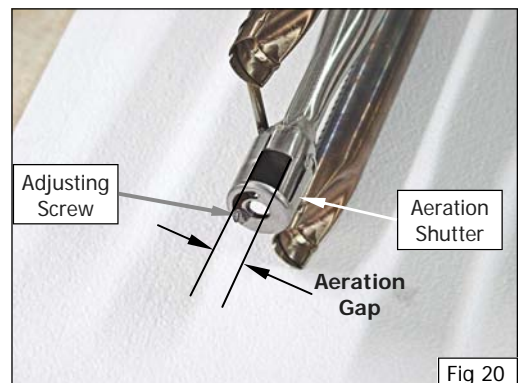
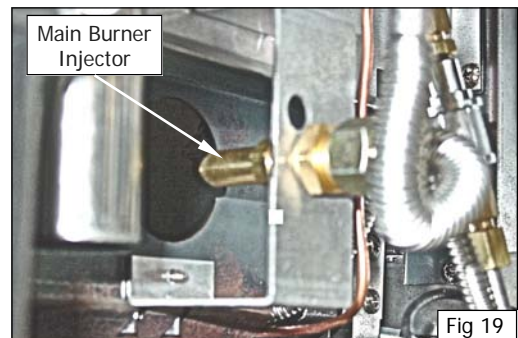
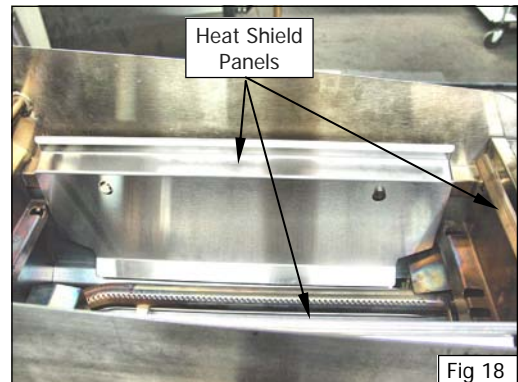

Pilot Burner

1. To remove the pilot burner, unscrew the 2 screws securing the pilot burner shield panel to the front inner face of the chargrill. Remove the panel from the chargrill.
2. Remove the 2 burner supports from the bottom of the chargrill.
3. Disconnect the gas connection to the pilot burner by unscrewing the connection at the base of the pilot injector using a 10mm A/F spanner.
4. Unscrew the 2 x 8mm screws securing clamp to the pilot bracket that retain the piezo igniter, thermocouple and pilot burner.
5. Remove the pilot burner from the pilot bracket (this is just a push fit into the bracket). **Note the orientation of the pilot burner in relation to the thermocouple and piezo igniter electrode as this is critical for the correct operation of the chargrill.**
6. Unscrew and remove the nut from the base of the Pilot Burner using a 11mm A/F spanner.

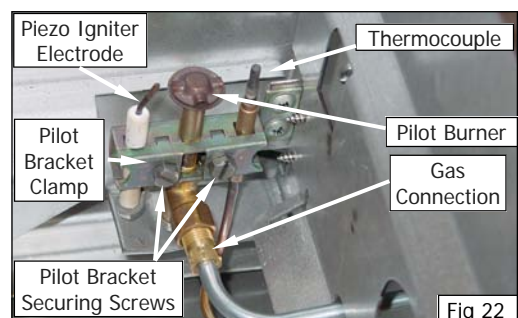
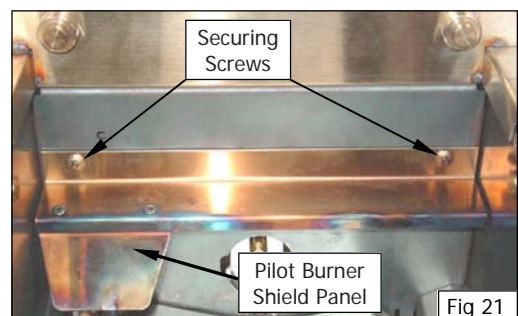

Gas Conversion and Specifications

7. Using a small flat blade screwdriver, unscrew and remove the pilot injector and spring from the base of the pilot burner.
8. Determine the correct injector size for the corresponding gas from the rating plate attached to the inner bulkhead adjacent to the manifold test point behind the front control panel or from the table at the rear of this section.
9. Refit the pilot injector and spring into the base of the pilot burner and tighten a small flat blade screwdriver, **Do not over tighten.**
10. Refit the nut to the base of the pilot burner and tighten hand tight using a 11mm A/F spanner.
11. Refit the pilot burner to the pilot burner bracket, ensuring that the pilot burner is correctly fitted into the bracket and is correctly orientated in respect to the thermocouple and piezo igniter electrode.
12. Refit the pilot burner clamp and secure with the 2 x 8mm screws, ensuring that the pilot burner, thermocouple and piezo igniter electrode are correctly positioned and secured. Tighten up the 2 x 8mm screws.
13. Re-connect the gas supply tube to the base of the pilot burner and tighten using a 11mm A/F spanner.
14. Refit the main burner supports to the base of the chargrill, ensuring that they locate into the cut-outs at the front and rear of the chargrill burner box and around the pilot burner bracket.
15. Refit the pilot burner shield panel to the front inner face of the chargrill and secure in place with the 2 screws.
16. Refit the main burner and ensure that the burner locates into the cut-outs in the burner supports and that the burner locates correctly over the main injector.
17. Refit the end heat shield panel. (This is a slot fit onto the front inner face of the chargrill).
18. Refit the left and right inner radiation panels (These are a slot fit onto either side of the chargrill).
19. Refit the inner radiants and castings to the chargrill.

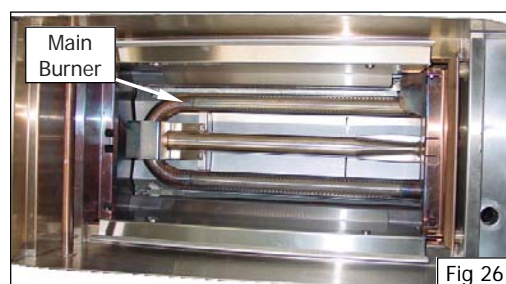
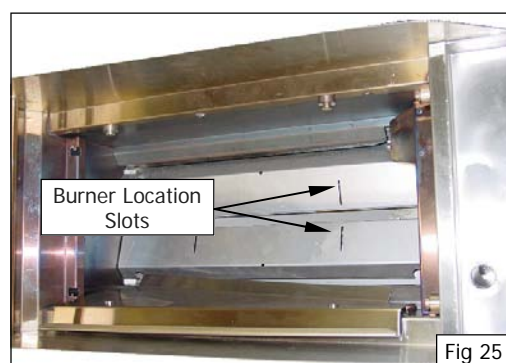
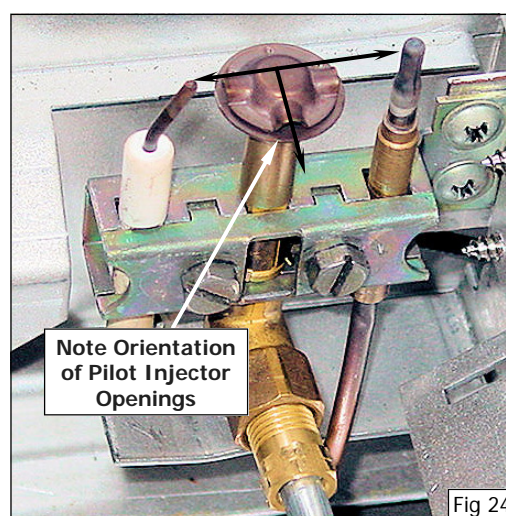
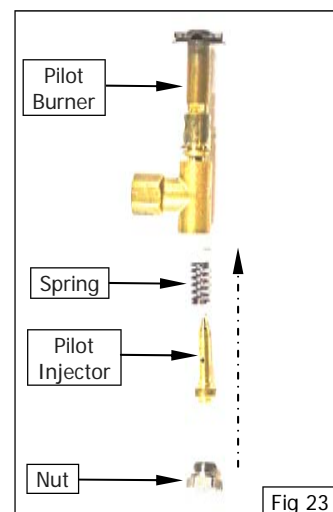

Gas Conversion and Specifications

Low Fire Adjustment (All Models)

1. To set the burner low fire adjustment, the low fire adjustment screw on the gas control valve should be screwed fully in, then un-screwed by the measurement shown in the 'Gas Specifications' table at the end of this section.

NOTE: The 'Low Fire Adjustment Screw' should be sealed with coloured paint on completion of the low fire adjustment.

2. Refit the front control panel to the chargrill and secure in position by tightening the 2 screws on the front lower edges of the control panel.
3. Refit the gas control knobs to the gas control valves. The gas control knobs are a push fit onto the shaft of the gas control valves.

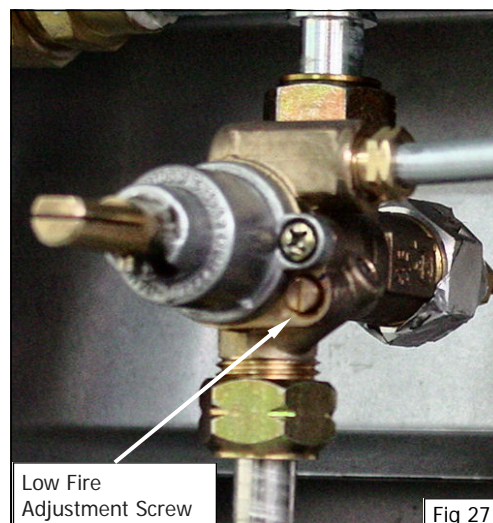

Gas Conversion and Specifications

Gas Regulator

NOTE: The regulator supplied is convertible between Natural Gas and LPG, but it's outlet pressure is fixed ex-factory and is NOT to be adjusted.

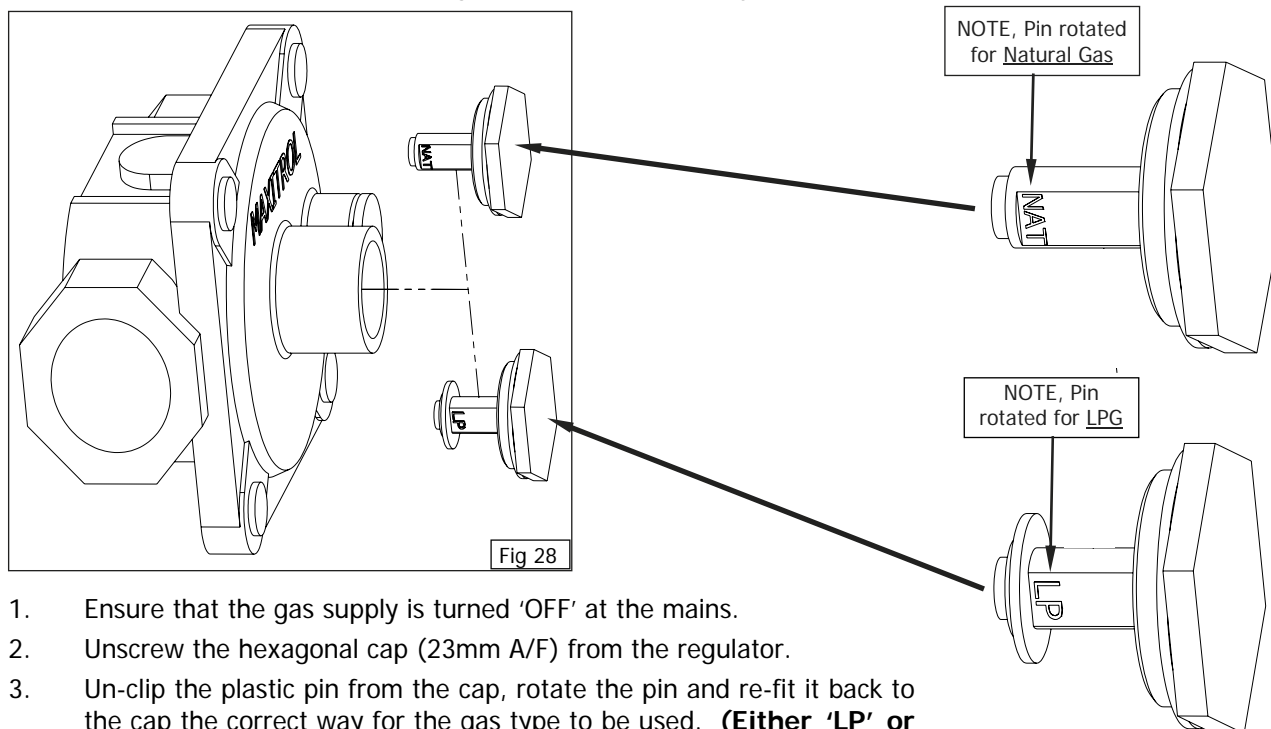

1. Ensure that the gas supply is turned 'OFF' at the mains.
2. Unscrew the hexagonal cap (23mm A/F) from the regulator.
3. Un-clip the plastic pin from the cap, rotate the pin and re-fit it back to the cap the correct way for the gas type to be used. **(Either 'LP' or 'NAT' should be visible on the flank of the pin once re-fitted to the cap).**
4. Screw the cap back into the regulator.

Gas Type Labels

On completion of the gas conversion, replace gas type labels located at:-

- The rear of the unit, above the gas connection.
- Beside the rating plate.

Commissioning

Before leaving the converted installation;

1. Check all gas connections for leakages using soapy water or other gas detecting equipment.

WARNING:

DO NOT USE A NAKED FLAME TO CHECK FOR GAS LEAKAGES.

2. Check the following functions in accordance with the operating instructions specified in the 'Operation' section of this manual.
 - Light the Pilot Burners.
 - Light the Main Burners.
 - Check the Low Fire burner operation.
 - Check the High Fire burner operation.
 - Ensure that all the controls operate correctly.
 - Ensure that the operating pressure remains correct.
3. Ensure any adjustments done to components that have the adjustments / settings sealed (e.g. paint sealed) are re-sealed.

NOTE: If for some reason it is not possible to get the unit to operate correctly, shut off the gas supply and contact the supplier of this unit.

Gas Conversion and Specifications

Gas Specifications

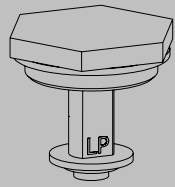
		Natural Gas (G20)		LP Gas (Propane) (G31)	
		CH8300G	CH8600G CH8900G CH8120G	CH8300G	CH8600G CH8900G CH8120G
Main Burner Injectors		2.70mm		1.65mm	
Pilot Burner Injectors		0.35	0.45	0.25	0.30
Low Fire Adjustment		1 ¹ / ₄ turns out (ccw)		½ turn out (ccw)	
Operating Pressure	Non - UK	1.00 kPa	0.95 kPa (*)	2.5 kPa (*)	2.6 kPa (*)
	UK - Only	10.6 mbar (*)	10 mbar (*)	25 mbar (*)	26 mbar (*)
Main Burner Aeration Shutter		Fully Open		Fully Open	
Gas Regulator Cap Screw					

NOTE:

* - The burner operating pressure is to be measured at the manifold test point with one burner for CH8300G Model or two burners for other models operating at full setting. The operating pressure is ex-factory set and not to be adjusted, apart from when converting between gases, if required. (Refer to the 'Gas Conversion' section for details).

Replacement Parts List

IMPORTANT:

Only genuine authorized replacement parts should be used for the servicing and repair of this appliance. The instructions supplied with the parts should be followed when replacing components.

For further information and servicing instructions, contact your nearest authorized service branch (contact details are as shown on the reverse of the front cover of this manual).

When ordering replacement parts, please quote the part number and the description as listed below. If the part required is not listed below, request the part by description and quote the model and serial number which is on the rating plate.

Chargrill 300mm - Main Assembly Parts List

ITEM	DESCRIPTION	PART NO
7	BURNER	227286
13	PIEZO - SIT	227508
20	SUPPLY PIPE	229563
21	BURNER SHIELD	229718
22	THERMOCOUPLE 320mm M9 x 1	019428
23	GAS VALVE 21S	227404
24	SPARK ELECTRODE	231540
25	PILOT ASSY 3 WAY	229719
	PILOT INJECTOR - 0.35mm - NAT GAS	227985
	PILOT INJECTOR - 0.25mm - LPG / PROPANE / BUTANE	227984
	PILOT INJECTOR - 0.60mm - TOWNS	232309
26	HT LEAD 250mm RING TERMINAL	229731
27	PILOT TUBE	229566
28	KNOB WALDORF 8mm GAS PF	227384
29	6" FLEXITUBE	022686
30	INJECTOR MOUNTING BUSH	227375
31	MAIN INJECTOR - 2.70mm - NAT GAS	037270
	MAIN INJECTOR - 1.65mm - LPG / PROPANE	037165
	MAIN INJECTOR - 1.55mm - BUTANE	037155
	MAIN INJECTOR - 4.50mm - TOWNS	037450

Replacement Parts

Chargrill 300mm - Main Assembly

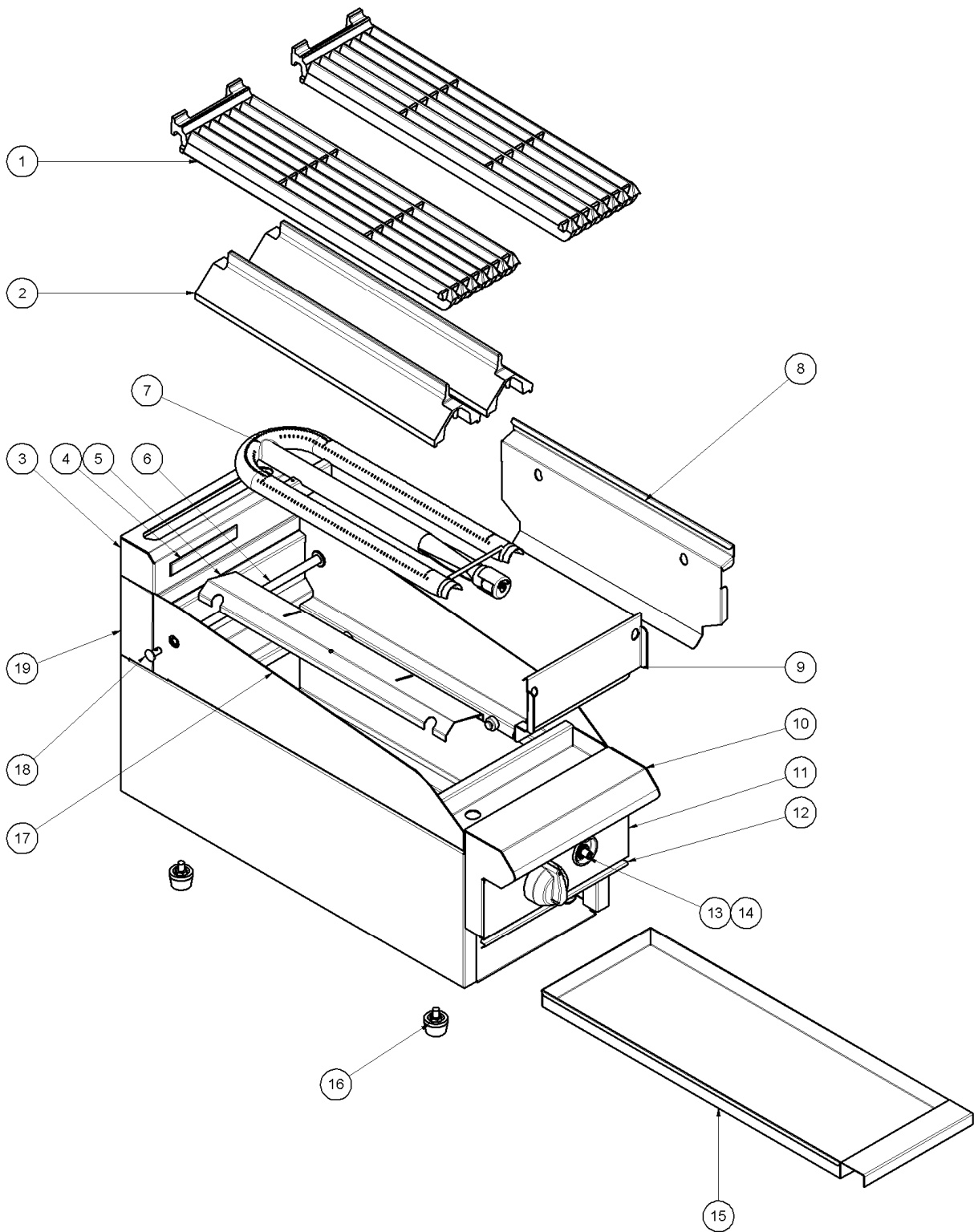

Chargrill 300mm - Gas System Assembly Parts List

ITEM	DESCRIPTION	PART NO
7	BURNER	227286
13	PIEZO - SIT	227508
20	SUPPLY PIPE	229563
21	BURNER SHIELD	229718
22	THERMOCOUPLE 320mm M9 x 1	019428
23	GAS VALVE 21S	227404
24	SPARK ELECTRODE	231540
25	PILOT ASSY 3 WAY	229719
	PILOT INJECTOR - 0.35mm - NAT GAS	227985
	PILOT INJECTOR - 0.25mm - LPG / PROPANE / BUTANE	227984
	PILOT INJECTOR - 0.60mm - TOWNS	232309
26	HT LEAD 250mm RING TERMINAL	229731
27	PILOT TUBE	229566
28	KNOB WALDORF 8mm GAS PF	227384
29	6" FLEXITUBE	022686
30	INJECTOR MOUNTING BUSH	227375
31	MAIN INJECTOR - 2.70mm - NAT GAS	037270
	MAIN INJECTOR - 1.65mm - LPG / PROPANE	037165
	MAIN INJECTOR - 1.55mm - BUTANE	037155
	MAIN INJECTOR - 4.50mm - TOWNS	037450

Replacement Parts

Chargrill 300mm - Gas System Assembly

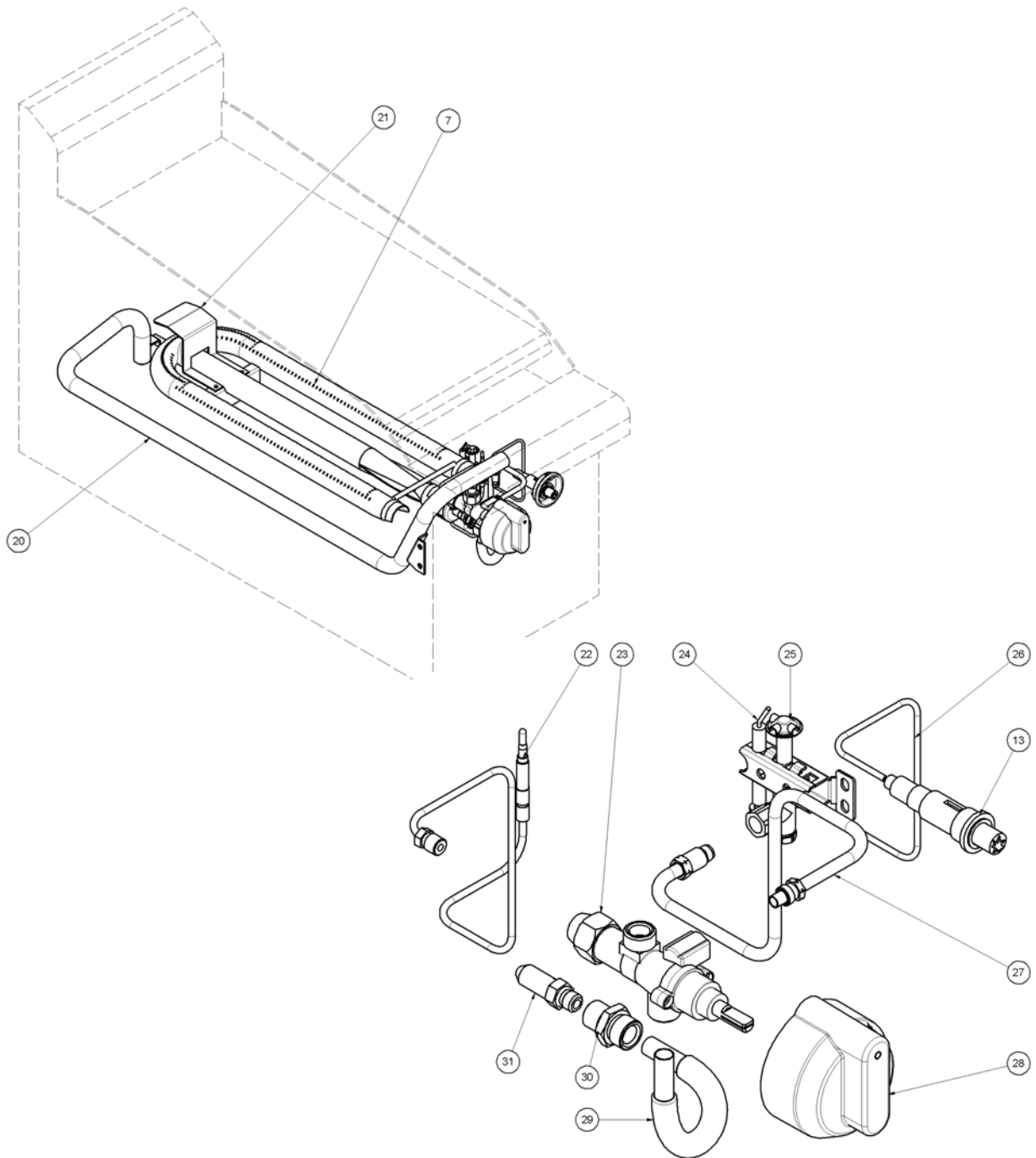

Replacement Parts

Chargrill 600mm / 900mm / 1200mm - Main Assembly Parts List

ITEM	DESCRIPTION	PART No.		
		CH8600G	CH8900G	CH8120G
1	BBQ TOP GRATE	227001		
1a	GRIDDLE PLATE BBQ (300mm)	227002 (OPTIONAL ACCESSORY)		
1a	GRIDDLE PLATE BBQ (450mm)	227003 (OPTIONAL ACCESSORY)		
1b	GRIDDLE WA (300mm)	230707 (OPTIONAL ACCESSORY)		
1b	GRIDDLE WA (450mm)	230710 (OPTIONAL ACCESSORY)		
2	CASTING BURNER RADIANT	014508		
3	WALDORF BADGE	227618		
4	GRATE SUPPORT	227263	227188	227264
5	SPLASHBACK WA WLDF	228004	228180	228181
6	BURNER SUPPORT	233729	233709	
7	BURNER	227286		
8	SIDE HEAT SHIELD BBQ	228440		
9	INNER RADIATION PANEL RH	-----	233688	233691
10	INNER RADIATION PANEL LH		233687	233690
10	INNER RADIATION PANEL	227271	---	---
11	NOSE RAIL WA WLDF	228006	228515	228516
12	CONTROL PANEL WLDF BBQ	227541	227540	227539
13	FRONT TRIM WLDF	227586	227583	227588
14	PIEZO HOUSING	228010		
15	PIEZO IGNITOR	227508		
16	CRUMB TRAY BBQ	228488	228487	228489
17	SILL WA WLDF	227898	227899	227900
18	LEG 150mm (EXTEND. STUD)	227851		
19	LEG RING PLATE PLAIN (LS)	229673		
19a	SCREW 5/8" x 1 HEX SET ZP	748010		
19b	REAR ROLLER ASSY	229674		
20	BASE TRAY	227408	227407	227409
21	LEG EXTENSION 430mm	227854		
22	FRAME WA CHARGRILL	227667	233748	233749
23	TUBE STOPPER	227189		
24	SPLASHBACK ENDS	228173		
25	LEG 80mm (FOR BENCH MOUNT)	227855		
26	FRAME WA - LOW BACK MODEL	233625	232988	233629
27	SPLASHBACK WA - LOW BACK MODEL	233149	232975	233608

Replacement Parts

Chargrill 600mm / 900mm / 1200mm - Main Assembly

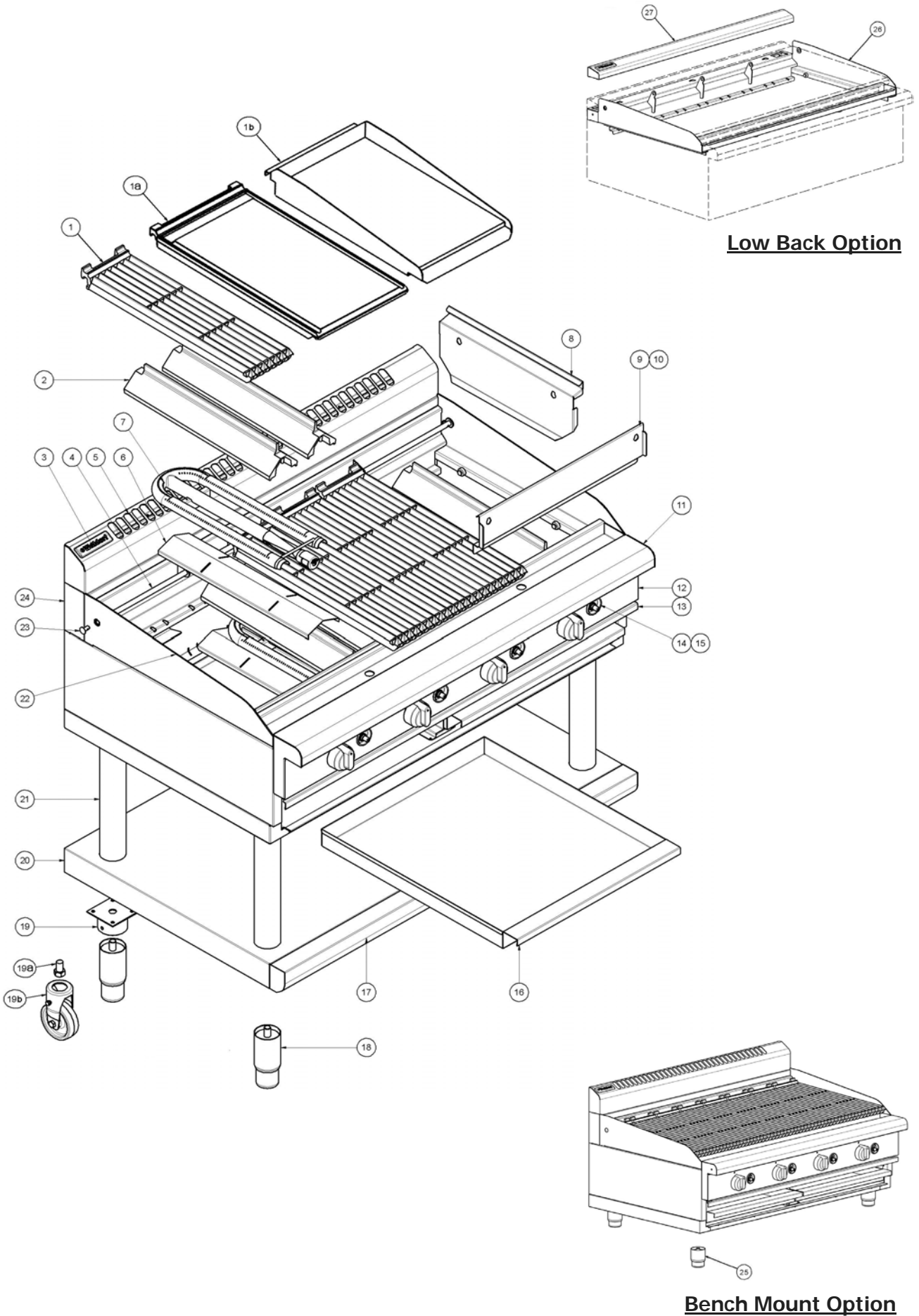

Replacement Parts

Chargrill 600mm / 900mm / 1200mm - Gas System Assembly

ITEM	DESCRIPTION	PART NO		
		CH8600G	CH8900G	CH8120G
7	BURNER	227286		
28	SUPPLY PIPE WA BBQ	227182		
29	UNION BRASS CONICAL 1/2" BSPT	016044		
30	MANIFOLD	227248	227187	227249
31	PILOT BURNER KIT - BBQ	019464K		
32	PILOT INJECTOR - 0.45mm - NAT	018972		
	PILOT INJECTOR - 0.30mm - LPG / PROPANE / BUTANE	018971		
	PILOT INJECTOR - 0.75mm - TOWNS	026393		
33	THERMOCOUPLE 450mm	019218		
34	FLEX TUBE 12" x 1/4"OD S/S	230319		
35	KNOB WALDORF 8mm GAS PF	227384		
36	6" FLEXTUBE	022686		
37	MAIN INJECTOR - 2.70mm - NAT GAS	037270		
	MAIN INJECTOR - 1.65mm - LPG / PROPANE	037165		
	MAIN INJECTOR - 1.55mm - BUTANE	037155		
	MAIN INJECTOR - 4.50mm - TOWNS	037450		
38	GAS VALVE 21S	227404		
39	ELECTRODE	019624		
	HT LEAD 250mm	228047		

Replacement Parts

Chargrill 600mm / 900mm / 1200mm - Gas System Assembly

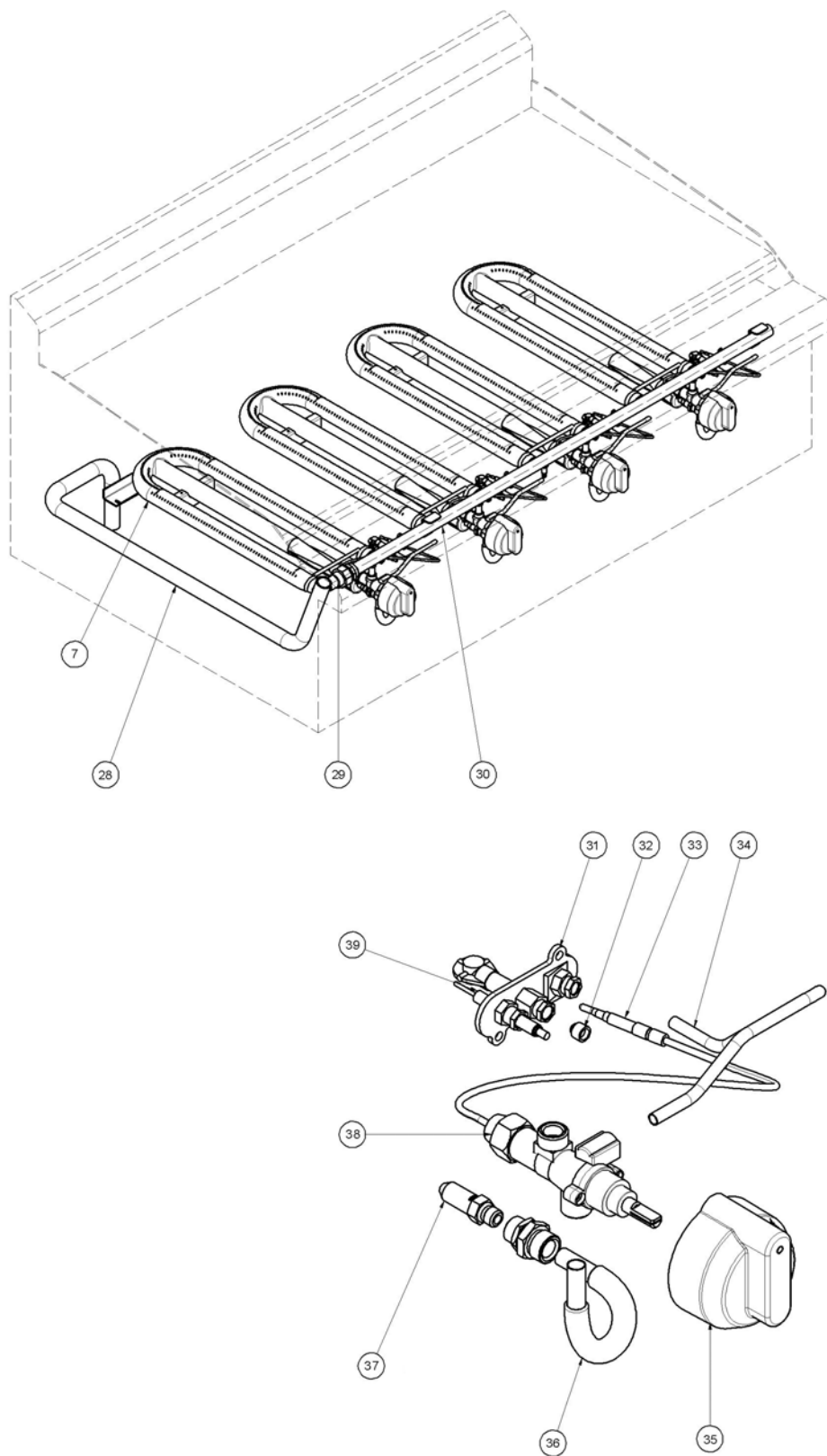

Gas Regulators

Gas Type	Model	Gas Regulators	
		Part No.	Description
Nat. Gas LPG Butane	CH8300G	228533	½" BSP F/F Convertible.
	CH8600G	228531	¾" BSP F/F Convertible.
	CH8900G		
	CH8120G		
Town Gas	ALL	230185	¾" BSP F/F Adjustable.

Gas Conversion Kits

Models	Gas Type to Convert to			
	Nat. Gas	LPG	Butane	Town Gas
CH8300G	231947	231946	231948	231949
CH8600G	231951	231950	231952	231953
CH8900G	231955	231954	231956	231957
CH8120G	231959	231958	231960	231961

Optional Accessories

Description	Part No
Casting Scraper Tool.	228787
Smooth Plate Scraper Blades (Pack of 5 blades).	228567
Chargrill Scraper Assembly.	228787
Drop-On Griddle Plate - 300mm (Cast, no sides) - (refer Chargrill Main Assy Drawing).	227002
Drop-On Griddle Plate - 450mm (Cast, no sides) - (refer Chargrill Main Assy Drawing).	227003
Drop-On Griddle Plate - 300mm (Steel, with sides) - (refer Chargrill Main Assy Drawing).	230707
Drop-On Griddle Plate - 450mm (Steel, with sides) - (refer Chargrill Main Assy Drawing).	230710
600mm Plinth Kit.	228795
900mm Plinth Kit.	228799
1200mm Plinth Kit.	228803

