

# INSTALLATION MANUAL

**R-410A**  
**J\*\*ZF SERIES 5**

**3 - 6 Ton**

**60 Hertz**

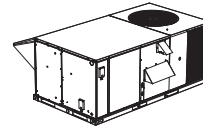

## TABLE OF CONTENTS

General . . . . .	2	Cooling Sequence Of Operation . . . . .	51
Installation . . . . .	5	No Outdoor Air Options . . . . .	51
Installation Safety Information . . . . .	5	Cooling Operation Errors . . . . .	52
Limitations . . . . .	5	Electric Heating Sequence Of Operations . . . . .	53
Location . . . . .	7	Electric Heat Operation Errors . . . . .	53
Rigging And Handling . . . . .	7	Gas Heating Sequence Of Operations . . . . .	54
Ductwork . . . . .	12	Gas Heat Operation Errors . . . . .	54
Condensate Drain . . . . .	12	Flash Codes . . . . .	55
Compressors . . . . .	12	Resets . . . . .	55
Filters . . . . .	13	Heat Anticipator Setpoints . . . . .	55
Power And Control Wiring . . . . .	13	Start-up (Cooling) . . . . .	56
Optional Electric Heat . . . . .	38	Start-up (Gas Heat) . . . . .	56
Options/Accessories . . . . .	41	Checking Gas Input . . . . .	58
Economizer And Power Exhaust Set Point Adjustments . . . . .	41	Charging The Unit . . . . .	59
Checking Supply Air CFM . . . . .	50	Troubleshooting . . . . .	59
Operation . . . . .	51	Fan On And Off Delays . . . . .	66

## LIST OF TABLES

1 J03 thru A6ZF Unit Limitations . . . . .	6	16 Indoor Blower Specifications (Belt Drive) . . . . .	50
2 Weights and Dimensions . . . . .	8	17 Power Exhaust Specifications . . . . .	50
3 J03 thru A6ZF Unit Accessory Weights . . . . .	8	18 Additional Static Resistance . . . . .	51
4 J03 thru A6ZF Unit Clearances . . . . .	10	19 Electric Heat Limit Setting . . . . .	53
5 J03 thru A6ZF Utilities Entry . . . . .	11	20 Electric Heat Anticipator Setpoints . . . . .	54
6 Control Wire Sizes . . . . .	14	21 Single Stage Gas Heat Limit Control Setting . . . . .	55
7 Electrical Data . . . . .	16	22 2 Stage Gas Heat Limit Control Setting . . . . .	55
8 Physical Data . . . . .	34	23 Gas Heat Anticipator Setpoints . . . . .	56
9 Electric Heat Minimum Supply Air . . . . .	38	24 Gas Rate-Cubit Feet per Hour . . . . .	58
10 Gas Heat Application Data . . . . .	38	25 J03ZF (3.0 Ton) Operating Pressures . . . . .	61
11 Gas Pipe Sizing - Capacity of Pipe . . . . .	39	26 J04ZF (4.0 Ton) Operating Pressures . . . . .	61
12 Altitude/Temperature Correction Factors . . . . .	43	27 J05ZF (5.0 Ton) Operating Pressures . . . . .	61
13 J**ZF Blower Performance Side Duct . . . . .	46	28 JA6ZF (6.0 Ton) Operating Pressures . . . . .	62
14 J**ZF Blower Performance Bottom Duct . . . . .	48	29 Unit Control Board Flash Codes . . . . .	66
15 Belt Drive RPM Selection . . . . .	49	30 Ignition Control Board Flash Codes . . . . .	66

## LIST OF FIGURES

1 J03 thru A6ZF Component Location . . . . .	6	13 Typical Field Power and Control Wiring . . . . .	15
2 Unit 4 Point Load Weight . . . . .	8	14 Side Entry Gas Piping . . . . .	39
3 Unit 6 Point Load Weight . . . . .	8	15 Bottom Entry Gas Piping . . . . .	39
4 Center of Gravity . . . . .	8	16 Vent And Combustion Air Hood . . . . .	41
5 J03 thru A6ZF Cooling Only/Electric Heat Front View Physical Dimensions . . . . .	9	17 Enthalpy Set Point Chart . . . . .	42
6 J03 thru A6ZF Cooling Only/Gas Heat Front View Physical Dimensions . . . . .	9	18 Honeywell Economizer Control W7212 . . . . .	42
7 J03 thru A6ZF Fixed Outdoor Air Motorized Damper Rain Hood Physical Dimensions . . . . .	10	19 Belt Adjustment . . . . .	42
8 J03 thru A6ZF Disconnect Location . . . . .	10	20 Altitude/Temperature Correction Factors . . . . .	43
9 J03 thru A6ZF Unit Side Duct Openings . . . . .	11	21 Pressure Drop Across Coil . . . . .	50
10 J03 thru A6ZF Roof Curb . . . . .	11	22 Gas Valve Piping . . . . .	54
11 Condensate Drain . . . . .	12	23 Typical Single Stage Gas Valves . . . . .	57
12 Compressor Restraining Bracket . . . . .	13	24 Typical 2 Stage Gas Valves . . . . .	57
		25 Proper Flame Adjustment . . . . .	57
		26 Typical Flame Appearance . . . . .	57
		27 Unit Control Board . . . . .	66

## General

JCI Model J\*\*ZF units are either single package cooling units equipped with optional factory installed electric heaters, or single package gas-fired central heating furnaces with cooling unit. Both are designed for outdoor installation on a rooftop or slab.

The units are completely assembled on rigid, permanently attached base rails. All piping, refrigerant charge, and electrical wiring is factory installed and tested. The units require electric power, gas connection, duct connections, installation of the weatherproof convenience outlet cover, combustion air inlet hood, flue gas outlet hoods and fixed outdoor air intake damper (units without economizer or motorized damper option only) at the point of installation.

The supplemental electric heaters have nickel-chrome elements and utilize single point power connection.

The gas-fired heaters have aluminized-steel (or optional stainless steel) tubular heat exchangers. The units have spark ignition with proven pilot. All gas heaters are shipped from the factory equipped for natural gas use, but can be field converted to L.P./ Propane with Kit Model #1NP0440 for single stage and Kit Model #1NP0485 for 2 stage.

### Safety Considerations

 This is a safety alert symbol. When you see this symbol on labels or in manuals, be alert to the potential for personal injury.

Understand and pay particular attention the signal words **DANGER**, **WARNING** or **CAUTION**.

**DANGER** indicates an **imminently** hazardous situation, which, if not avoided, **will result in death or serious injury**.

**WARNING** indicates a **potentially** hazardous situation, which, if not avoided, **could result in death or serious injury**.

**CAUTION** indicates a potentially hazardous situation, which, if not avoided **may result in minor or moderate injury**. It is also used to alert against unsafe practices and hazards involving only property damage.

### WARNING

Improper installation may create a condition where the operation of the product could cause personal injury or property damage. Improper installation, adjustment, alteration, service or maintenance can cause injury or property damage. Refer to this manual for assistance or for additional information, consult a qualified contractor, installer or service agency.

### CAUTION

This product must be installed in strict compliance with the installation instructions and any applicable local, state and national codes including, but not limited to building, electrical, and mechanical codes.

### WARNING

Before performing service or maintenance operations on unit, turn off main power switch to unit. Electrical shock could cause personal injury. Improper installation, adjustment, alteration, service or maintenance can cause injury or property damage. Refer to this manual. For assistance or additional information consult a qualified installer, service agency or the gas supplier.

### CAUTION

This system uses R-410A Refrigerant which operates at higher pressures than R-22. No other refrigerant may be used in this system. Gage sets, hoses, refrigerant containers and recovery systems must be designed to handle R-410A. If you are unsure, consult the equipment manufacturer. Failure to use R-410A compatible servicing equipment may result in property damage or injury.

### WARNING

If the information in this manual is not followed exactly, a fire or explosion may result causing property damage, personal injury or loss of life.

Do not store or use gasoline or other flammable vapors and liquids in the vicinity of this or any other appliance.

#### WHAT TO DO IF YOU SMELL GAS:

- a. Do not try to light any appliance.
- b. Do not touch any electrical switch; do not use any phone in your building.
- c. Immediately call your gas supplier from a neighbor's phone. Follow the gas supplier's instructions.
- d. If you cannot reach your gas supplier, call the fire department.

Installation and service must be performed by a qualified installer, service agency or the gas supplier.

Due to system pressure, moving parts, and electrical components, installation and servicing of air conditioning equipment can be hazardous. Only qualified, trained service personnel should install, repair, or service this equipment. Untrained personnel can perform basic maintenance functions of cleaning coils and filters and replacing filters.

Observe all precautions in the literature, labels, and tags accompanying the equipment whenever working on air conditioning equipment. Be sure to follow all other applicable safety precautions and codes including ANSI Z223.1 or CSA-B149.1- latest edition.

Wear safety glasses and work gloves. Use quenching cloth and have a fire extinguisher available during brazing operations.

### Inspection

As soon as a unit is received, it should be inspected for possible damage during transit. If damage is evident, the extent of the damage should be noted on the carrier's freight bill. A separate request for inspection by the carrier's agent should be made in writing.

### CAUTION

This product must be installed in strict compliance with the enclosed installation instructions and any applicable local, state and national codes including, but not limited to, building, electrical, and mechanical codes.

The furnace and its individual shut-off valve must be disconnected from the gas supply piping system during any pressure testing at pressures in excess of 1/2 PSIG.

Pressures greater than 1/2 PSIG will cause gas valve damage resulting in a hazardous condition. If it is subjected to a pressure greater than 1/2 PSIG, the gas valve must be replaced.

The furnace must be isolated from the gas supply piping system by closing its individual manual shut-off valve during any pressure testing of the gas supply piping system at test pressures equal to or less than 1/2 PSIG.

### Reference

Additional information is available in the following reference forms:

- Technical Guide - J03 thru A6ZF, 349666
- General Installation - J03 thru A6ZF, 697946

### Renewal Parts

Contact your local JCI parts distribution center for authorized replacement parts.

### Approvals

Design certified by CSA as follows:

1. For use as a cooling only unit, cooling unit with supplemental electric heat or a forced air furnace.
2. For outdoor installation only.
3. For installation on combustible material.
4. For use with natural gas (convertible to LP with kit).

### CAUTION

This product must be installed in strict compliance with the enclosed installation instructions and any applicable local, state, and national codes including, but not limited to, building, electrical, and mechanical codes.

### WARNING

Improper installation may create a condition where the operation of the product could cause personal injury or property damage.

### CAUTION

This system uses R-410A Refrigerant which operates at higher pressures than R-22. No other refrigerant may be used in this system.

**Product Nomenclature**

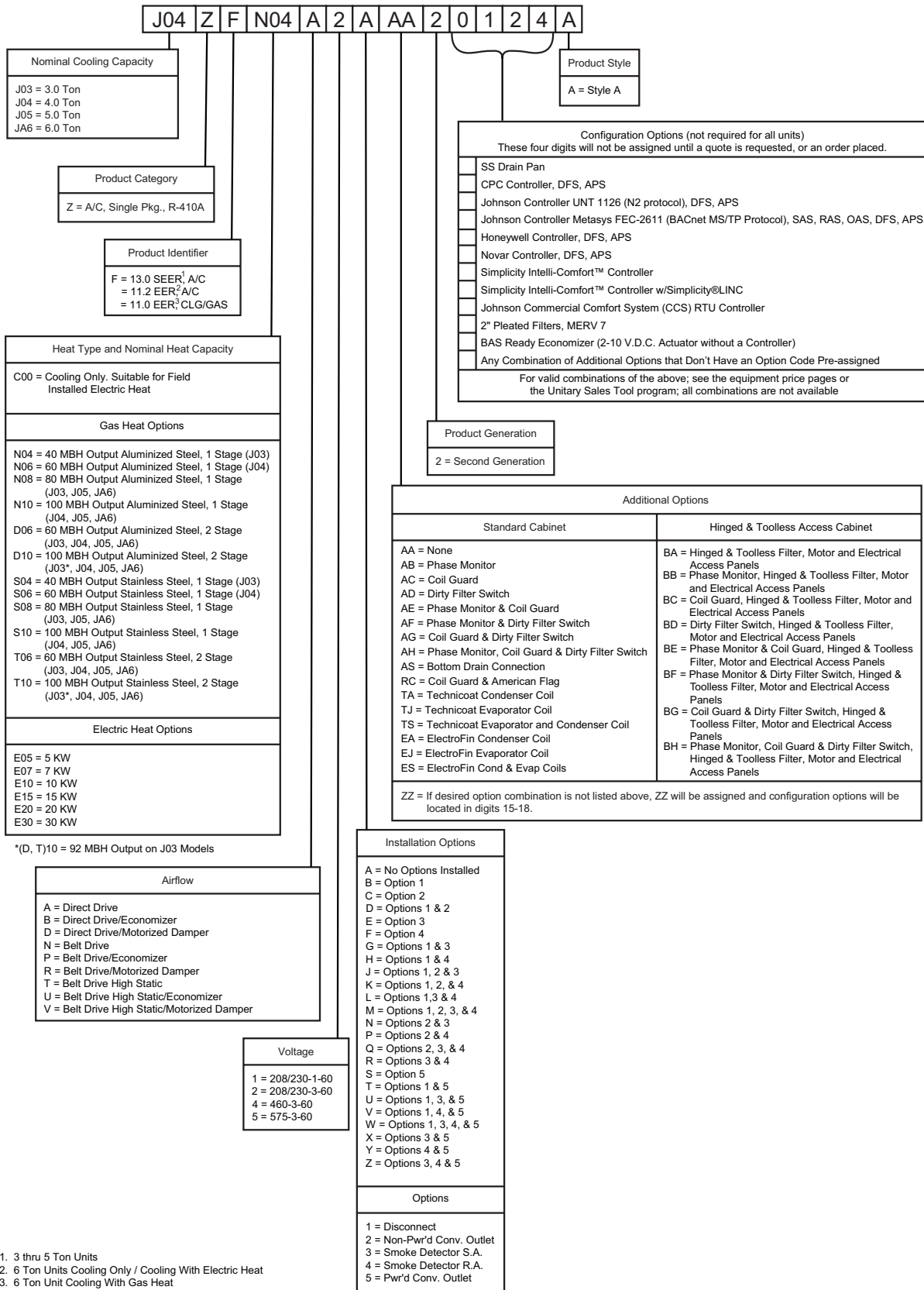

## Installation

### Installation Safety Information

Read these instructions before continuing this appliance installation. This is an outdoor combination heating and cooling unit. The installer must assure that these instructions are made available to the consumer and with instructions to retain them for future reference.

1. Refer to the unit rating plate for the approved type of gas for this product.
2. Install this unit only in a location and position as specified on Page 7 of these instructions.
3. Never test for gas leaks with an open flame. Use commercially available soap solution made specifically for the detection of leaks when checking all connections, as specified on Pages 5, 40, 40 and 56 of these instructions.
4. Always install furnace to operate within the furnace's intended temperature-rise range with the duct system and within the allowable external static pressure range, as specified on the unit name/rating plate, specified on page 38 of these instructions.
5. This equipment is not to be used for temporary heating of buildings or structures under construction.

### WARNING

#### FIRE OR EXPLOSION HAZARD

Failure to follow the safety warning exactly could result in serious injury, death or property damage.

Never test for gas leaks with an open flame. use a commercially available soap solution made specifically for the detection of leaks to check all connections. A fire or explosion may result causing property damage, personal injury or loss of life.

6. If a factory option convenience outlet is installed, the weatherproof outlet cover must be field installed. The cover shall be located behind the blower access panel. To install the cover, remove the shipping label covering the convenience outlet and attach the cover to the unit using the (4) screws provided.

### CAUTION

208/230-3-60 and 380/415-3-50 units with factory installed Powered Convenience Outlet Option are wired for 230v and 415v power supply respectively. Change tap on transformer for 208-3-60 or 380-3-50 operation. See unit wiring diagram.

## Limitations

These units must be installed in accordance with the following:

### In U.S.A.:

1. National Electrical Code, ANSI/NFPA No. 70 - Latest Edition
2. National Fuel Gas Code, ANSI Z223.1 - Latest Edition
3. Gas-Fired Central Furnace Standard, ANSI Z21.47a. - Latest Edition
4. Local building codes, and
5. Local gas utility requirements

### In Canada:

1. Canadian Electrical Code, CSA C22.1
2. Installation Codes, CSA - B149.1.
3. Local plumbing and waste water codes, and
4. Other applicable local codes.

Refer to unit application data found in this document.

After installation, gas fired units must be adjusted to obtain a temperature rise within the range specified on the unit rating plate.

If components are to be added to a unit to meet local codes, they are to be installed at the dealer's and/or customer's expense.

Size of unit for proposed installation should be based on heat loss/heat gain calculation made according to the methods of Air Conditioning Contractors of America (ACCA).

This furnace is not to be used for temporary heating of buildings or structures under construction.

### CAUTION

The Simplicity® control board used in this product will effectively operate the cooling system down to 0°F when this product is applied in a comfort cooling application for people. An economizer is typically included in this type of application. When applying this product for process cooling applications (computer rooms, switchgear, etc.), please reference applications bulletin AE-011-07 or call the applications department for Unitary Products @ 1-877-UPG-SERV for guidance. Additional accessories may be needed for stable operation at temperatures below 30° F.

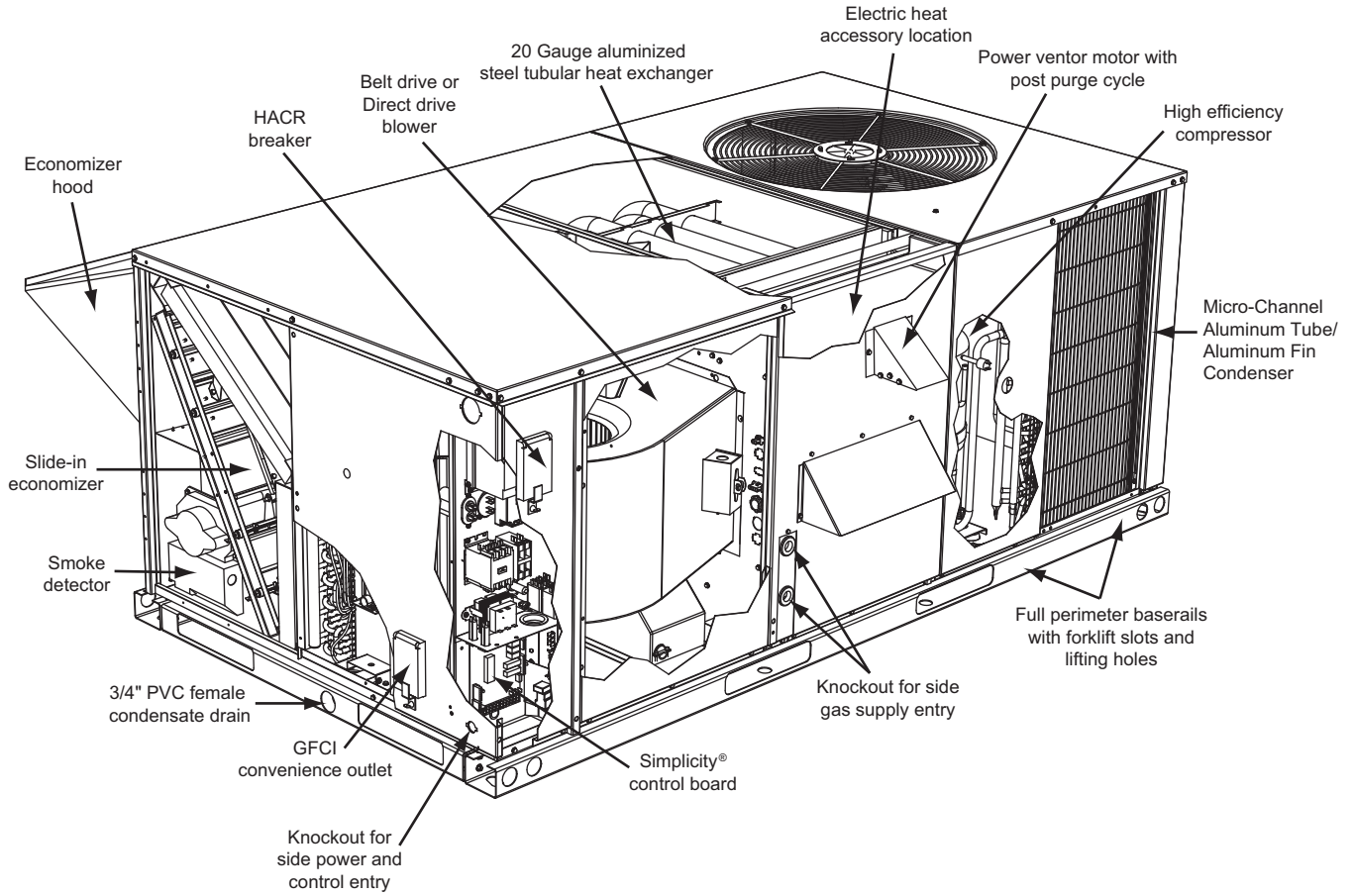

**Figure 1: J03 thru A6ZF Component Location**

**Table 1: J03 thru A6ZF Unit Limitations**

Size (Tons)	Unit Voltage	Unit Limitations		
		Applied Voltage		Outdoor DB Temp
		Min	Max	Max (°F)
J03 (3.0)	208/230-1-60	187	252	125
	208/230-3-60	187	252	125
	460-3-60	432	504	125
	575-3-60	540	630	125
J04 (4.0)	208/230-1-60	187	252	125
	208/230-3-60	187	252	125
	460-3-60	432	504	125
	575-3-60	540	630	125
J05 (5.0)	208/230-1-60	187	252	125
	208/230-3-60	187	252	125
	460-3-60	432	504	125
	575-3-60	540	630	125
JA6 (6.0)	208/230-3-60	187	252	125
	460-3-60	432	504	125
	575-3-60	540	630	125

## Location

Use the following guidelines to select a suitable location for these units:

1. Unit is designed for *outdoor installation only*.
2. Condenser coils must have an unlimited supply of air. Where a choice of location is possible, position the unit on either north or east side of building.
3. Suitable for mounting on roof curb.
4. For ground level installation, use a level concrete slab with a minimum thickness of 4 inches. The length and width should be at least 6 inches greater than the unit base rails. Do not tie slab to the building foundation.
5. Roof structures must be able to support the weight of the unit and its options/accessories. Unit must be installed on a solid, level roof curb or appropriate angle iron frame.
6. Maintain level tolerance to 1/2" across the entire width and length of unit.

### WARNING

Excessive exposure of this furnace to contaminated combustion air may result in equipment damage or personal injury. Typical contaminants include: permanent wave solution, chlorinated waxes and cleaners, chlorine based swimming pool chemicals, water softening chemicals, carbon tetrachloride, Halogen type refrigerants, cleaning solvents (e.g. perchloroethylene), printing inks, paint removers, varnishes, hydrochloric acid, cements and glues, antistatic fabric softeners for clothes dryers, masonry acid washing materials.

## Clearances

All units require particular clearances for proper operation and service. Installer must make provisions for adequate combustion and ventilation air in accordance with section 5.3 of Air for Combustion and Ventilation of the National Fuel Gas Code, ANSI Z223.1 – Latest Edition (in U.S.A.), or Sections 7.2, 7.3, or 7.4 of Gas Installation Codes, CSA-B149.1 (in Canada) - Latest Edition, and/or applicable provisions of the local building

codes. Refer to Table 4 for clearances required for combustible construction, servicing, and proper unit operation.

### WARNING

Do not permit overhanging structures or shrubs to obstruct condenser air discharge outlet, combustion air inlet or vent outlets.

## Rigging And Handling

Exercise care when moving the unit. Do not remove any packaging until the unit is near the place of installation. Rig the unit by attaching chain or cable slings to the lifting holes provided in the base rails. Spreader bars, whose length exceeds the largest dimension across the unit, **MUST** be used across the top of the unit.

### CAUTION

If a unit is to be installed on a roof curb other than a JCI roof curb, gasketing must be applied to all surfaces that come in contact with the unit underside.

### CAUTION

Before lifting, make sure the unit weight is distributed equally on the rigging cables so it will lift evenly.

Units may be moved or lifted with a forklift. Slotted openings in the base rails are provided for this purpose.

**LENGTH OF FORKS MUST BE A MINIMUM OF 42 INCHES.**

### CAUTION

All panels must be secured in place when the unit is lifted.  
The condenser coils should be protected from rigging cable damage with plywood or other suitable material.

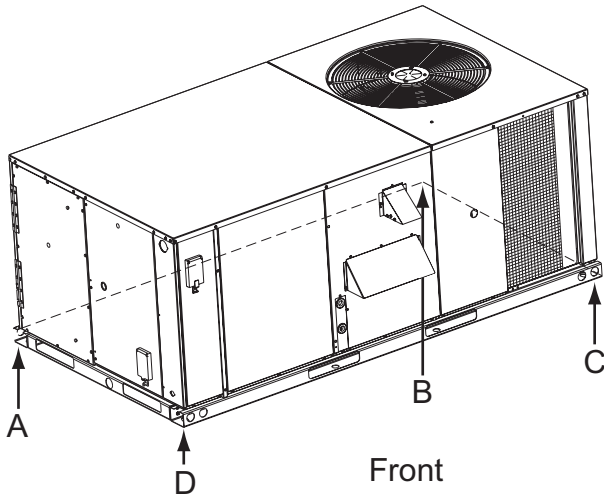

Figure 2: Unit 4 Point Load Weight

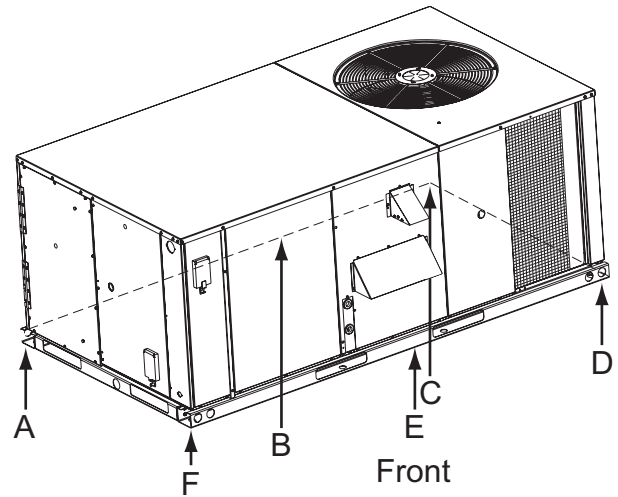

Figure 3: Unit 6 Point Load Weight

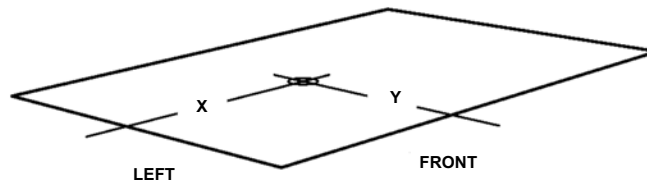

Figure 4: Center of Gravity

Table 2: Weights and Dimensions

Size (Tons)	Weight (lbs.)		Center of Gravity		4 Point Load Location (lbs.)				6 Point Load Location (lbs.)					
	Shipping	Operating	X	Y	A	B	C	D	A	B	C	D	E	F
J03 (3.0)	473	468	33	18.25	114	76	111	166	81	61	48	70	89	119
J04 (4.0)	546	541	31.5	18.5	138	85	122	196	100	71	53	75	101	142
J05 (5.0)	574	569	37	15	105	86	170	208	72	63	55	110	125	144
JA6 (6.0)	645	640	37	15	118	96	192	234	81	71	62	124	141	162

Table 3: J03 thru A6ZF Unit Accessory Weights

Unit Accessory	Weight (lbs.)	
	Shipping	Operating
Economizer	55	50
Power Exhaust	55	50
Electric Heat <sup>1</sup>	28	28
Gas Heat <sup>2</sup>	70	70

1. Weight given is for the maximum heater size available (30KW).
2. Weight given is for the maximum number of tube heat exchangers available (5 tube).



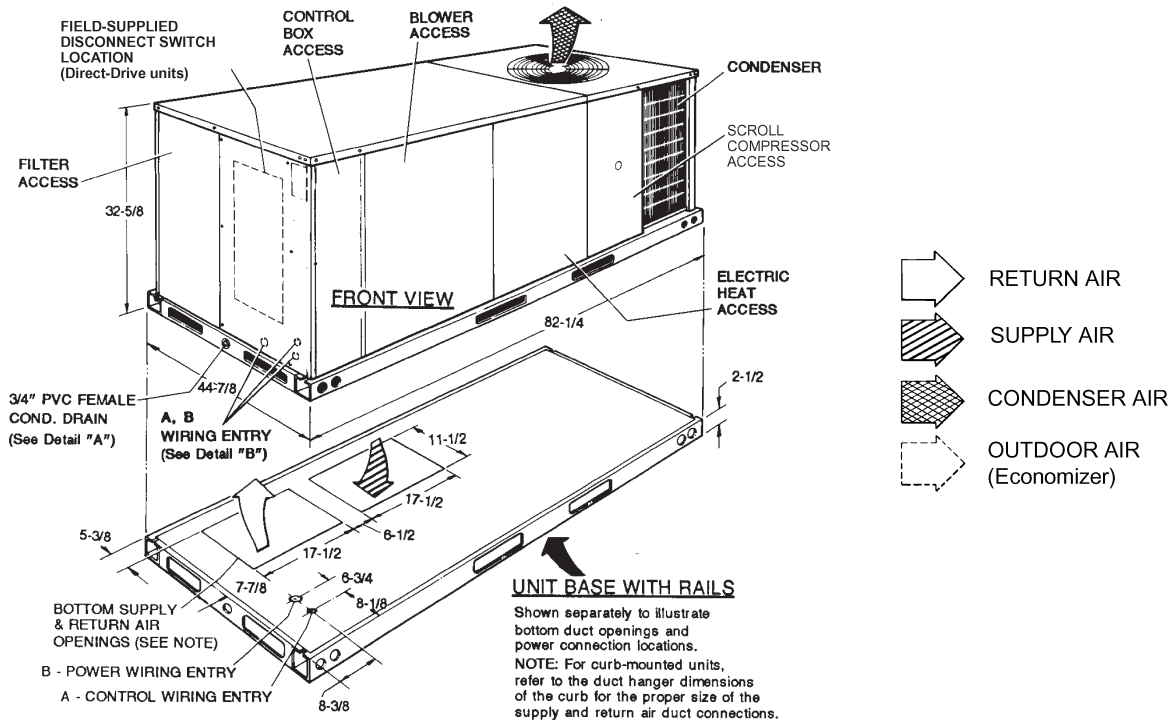

Figure 5: J03 thru A6ZF Cooling Only/Electric Heat Front View Physical Dimensions

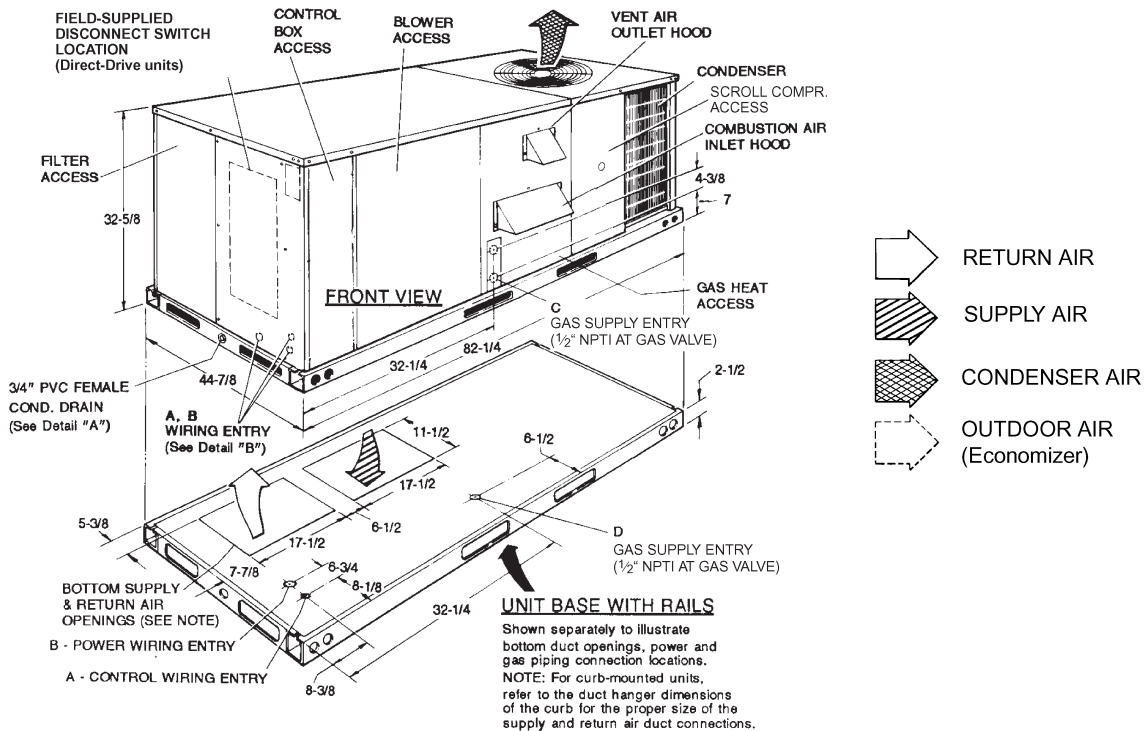

Figure 6: J03 thru A6ZF Cooling Only/Gas Heat Front View Physical Dimensions

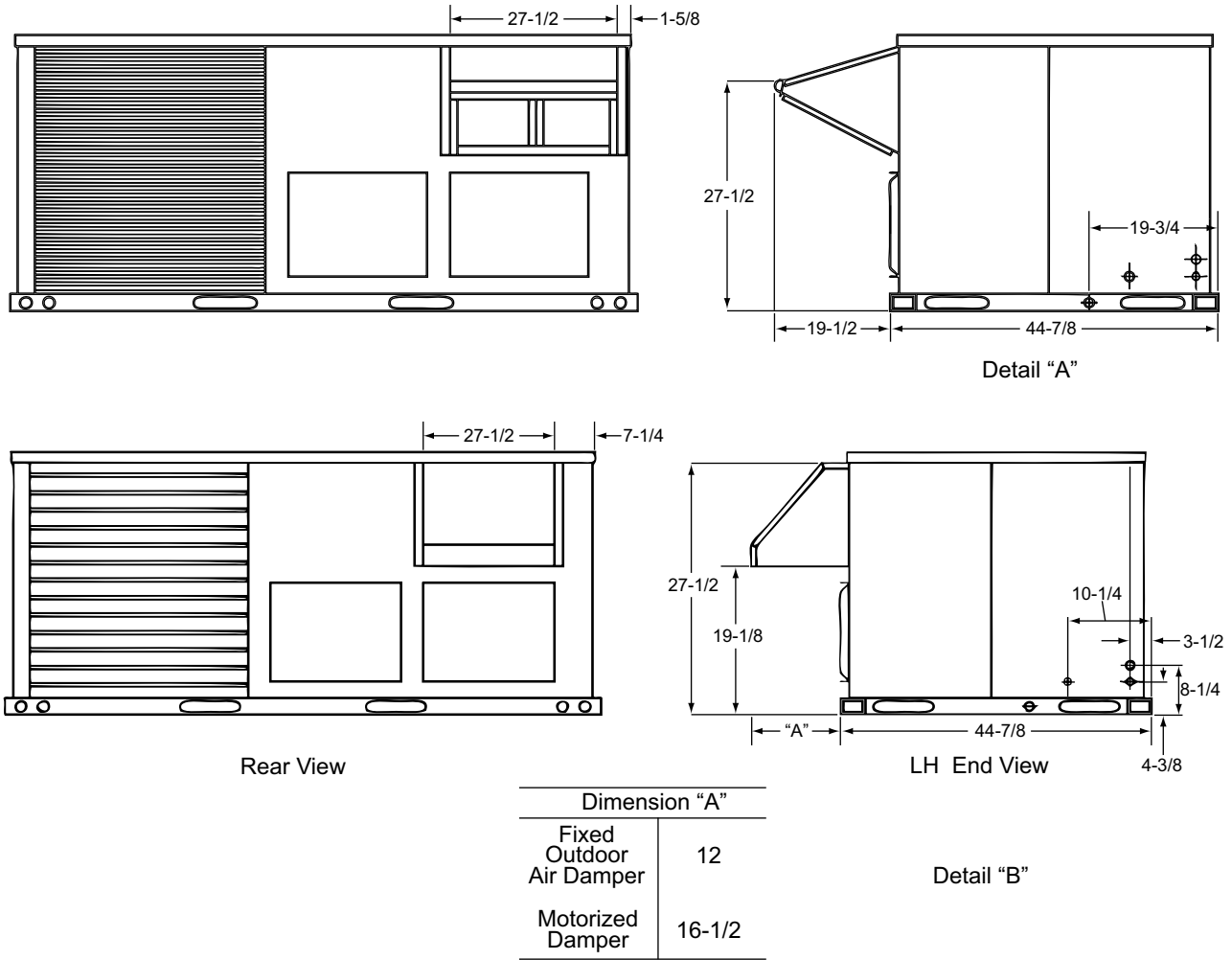

Figure 7: J03 thru A6ZF Fixed Outdoor Air Motorized Damper Rain Hood Physical Dimensions

Table 4: J03 thru A6ZF Unit Clearances

Location	Clearance
Front	24" (Cooling/Electric Heat) 32" (Gas Heat)
Rear	12" (Less Economizer) 36" (With Economizer or Fixed Air/Motorized Damper)
Left Side (Filter Access)	24" (Less Economizer) 36" (With Economizer)
Right Side (Cond. Coil)	24"
Below Unit <sup>1</sup>	0"
Above Unit <sup>2</sup>	72" (For Condenser Air Discharge)

- Units may be installed on combustible floors made from wood or class A, B, or C roof covering material.
- Units must be installed outdoors. Overhanging structures or shrubs should not obstruct condenser air discharge outlet.

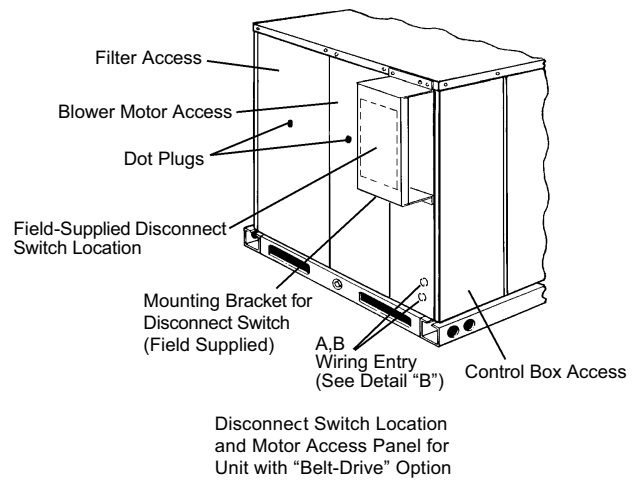
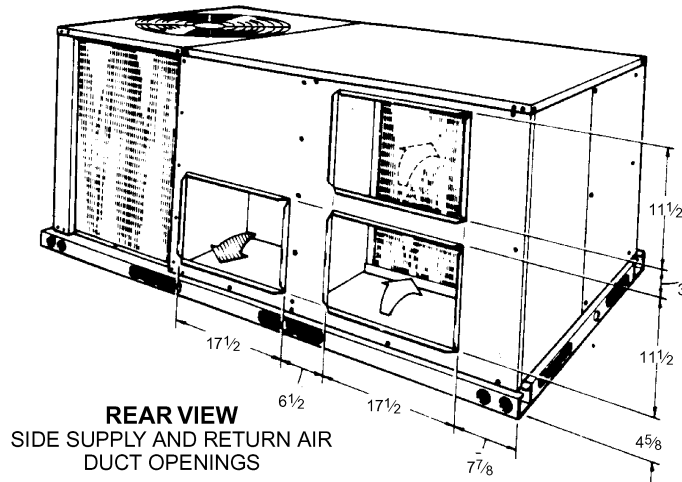

Figure 8: J03 thru A6ZF Disconnect Location



**DUCT COVERS** - Units are shipped with all air duct openings covered.  
 For side duct applications;  
 1. Remove and discard the supply and return air duct covers.  
 2. Connect ductwork to duct flanges on the rear of the unit.  
 For bottom duct applications;  
 1. Remove the side supply air duct cover to gain access to the bottom supply air knockout panel.  
 2. Remove and discard the bottom knockout panel.  
 3. Replace the side duct cover.  
 4. With filter section access panel removed from the unit, remove and discard the bottom return air knockout panel.  
 5. Replace the filter access panel.

**Figure 9: J03 thru A6ZF Unit Side Duct Openings**

**Table 5: J03 thru A6ZF Utilities Entry**

Hole	Opening Size (Dia.)	Used For
A	7/8" KO <sup>1</sup>	Control Wiring <sup>2</sup>
		Side
		Bottom
B	2" KO <sup>1</sup>	Power Wiring
		Side
		Bottom
C	1-5/8" KO	Gas Piping (Front)
D	1-1/2" KO	Gas Piping (Bottom)

1. Opening in the bottom to the unit can be located by the slice in the insulation.
2. Do not remove the 2" knockout ring.

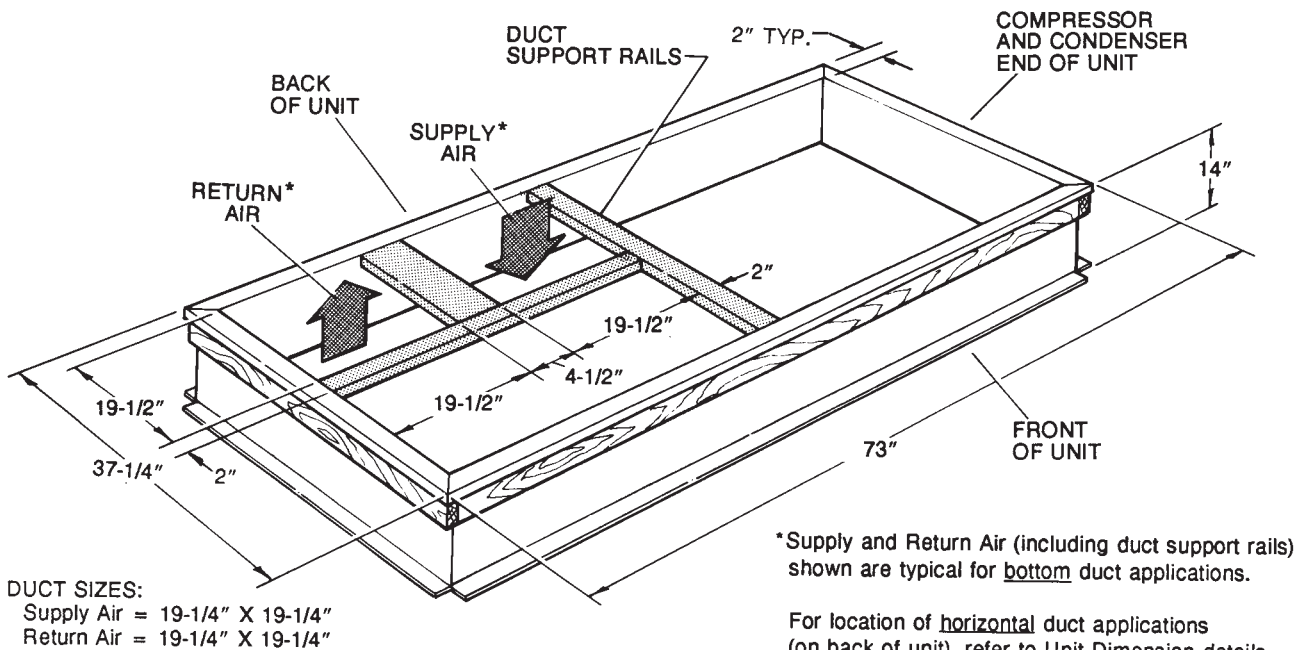

\* Supply and Return Air (including duct support rails) shown are typical for bottom duct applications.

For location of horizontal duct applications (on back of unit), refer to Unit Dimension details.

**Figure 10: J03 thru A6ZF Roof Curb**

## Ductwork

Ductwork should be designed and sized according to the methods in Manual D of the Air Conditioning Contractors of America (ACCA) or as recommended by any other recognized authority such as ASHRAE or SMACNA.

A closed return duct system should be used. This will not preclude use of economizers or outdoor fresh air intake. The supply and return air duct connections at the unit should be made with flexible joints to minimize noise.

The supply and return air duct systems should be designed for the CFM and static pressure requirements of the job. They should NOT be sized to match the dimensions of the duct connections on the unit.

Refer to Figures 5 and 6 for bottom air duct openings. Refer to Figure 9 for side air duct openings.

### CAUTION

When fastening ductwork to side duct flanges on unit, insert screws through duct flanges only. DO NOT insert screws through casing. Outdoor ductwork must be insulated and water-proofed.

**NOTE:** It is recommended that, in Canada, the outlet duct be provided with a removable access panel. It is recommended that this opening be accessible when the unit is installed in service, and of a size such that smoke or reflected light may be observed inside the casing to indicate the presence of leaks in the heat exchanger. The cover should be attached in a manner adequate to prevent leakage.

## Condensate Drain

Plumbing must conform to local codes. Use a sealing compound on male pipe threads. Install a condensate drain line from the 3/4" NPT female connection on the unit to an open drain.

**NOTE:** The condensate drain operates in a negative pressure in the cabinet. The condensate drain line MUST be trapped to provide proper drainage. See Figure 11.

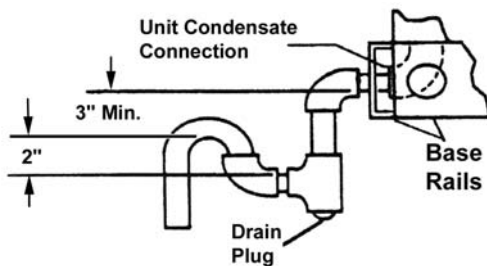

Figure 11: Condensate Drain

## Compressors

The scroll compressor used in this product is specifically designed to operate with R-410A Refrigerant and cannot be interchanged.

### CAUTION

This system uses R-410A Refrigerant which operates at higher pressures than R-22. No other refrigerant may be used in this system.

The compressor also uses a polyolester (POE oil), Mobil 3MA POE. This oil is extremely hygroscopic, meaning it absorbs water readily. POE oil can absorb 15 times as much water as other oils designed for HCFC and CFC refrigerants. Take all necessary precautions to avoid exposure of the oil to the atmosphere.

### CAUTION

Do not leave the system open to the atmosphere. Unit damage could occur due to moisture being absorbed by the **POE oil** in the system. This type of oil is highly susceptible to moisture absorption.

POE (polyolester) compressor lubricants are known to cause long term damage to some synthetic roofing materials.

### CAUTION

Exposure, even if immediately cleaned up, may cause embrittlement (leading to cracking) to occur in one year or more. When performing any service that may risk exposure of compressor oil to the roof, take precautions to protect roofing.

Procedures which risk oil leakage include, but are not limited to, compressor replacement, repairing refrigerant leaks, replacing refrigerant components such as filter drier, pressure switch, metering device or coil.

Units are shipped with compressor mountings which are factory-adjusted and ready for operation.

Units with scroll compressors have a shipping bracket which must be removed after the unit is set in place. See Figure 12.

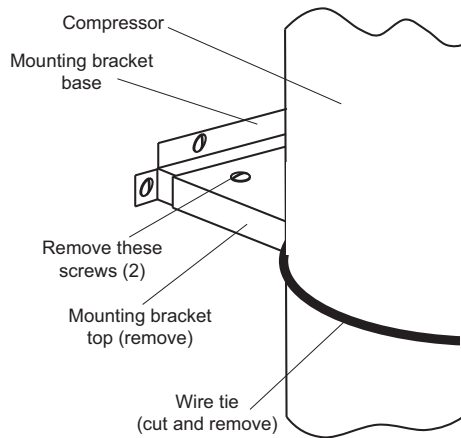

**Figure 12: Compressor Restraining Bracket**

### CAUTION

Do not loosen compressor mounting bolts.

### Filters

One or two-inch filters can be supplied with each unit. One-inch filters may be used with no modification to the filter racks. Filters must always be installed ahead of evaporator coil and must be kept clean or replaced with same size and type. Dirty filters reduce the capacity of the unit and result in frosted coils or safety shutdown. Refer to physical data tables, for the number and size of filters needed for the unit. The unit should not be operated without filters properly installed.

### CAUTION

Make sure that panel latches are properly positioned on the unit to maintain an airtight seal.

### Power And Control Wiring

Field wiring to the unit, fuses, and disconnects must conform to provisions of National Electrical Code (NEC), ANSI/NFPA No. 70 – Latest Edition (in U.S.A.), current Canadian Electrical Code C221, and/or local ordinances. The unit must be electrically grounded in accordance with NEC and CEC as specified above and/or local codes.

Voltage tolerances which must be maintained at the compressor terminals during starting and running conditions are indicated on the unit Rating Plate and Table 1.

### CAUTION

208/230-3-60 and 380/415-3-50 units control transformers are factory wired for 230v and 415v power supply respectively. Change tap on transformer for 208-3-60 or 380-3-50 operation. See unit wiring diagram.

The internal wiring harnesses furnished with this unit are an integral part of the design certified unit. Field alteration to comply with electrical codes should not be required. If any of the wire supplied with the unit must be replaced, replacement wire must be of the type shown on the wiring diagram and the same minimum gauge as the replaced wire.

A disconnect must be utilized for these units. Factory installed disconnects are available. If installing a disconnect (field supplied or York International® supplied accessory), refer to Figure 8 for the recommended mounting location.

### CAUTION

Avoid damage to internal components if drilling holes for disconnect mounting.

**NOTE:** Since not all local codes allow the mounting of a disconnect on the unit, please confirm compliance with local code before mounting a disconnect on the unit.

Electrical line must be sized properly to carry the load. USE COPPER CONDUCTORS ONLY. Each unit must be wired with a separate branch circuit fed directly from the meter panel and properly fused.

Refer to Figure 13 for typical field wiring and to the appropriate unit wiring diagram mounted inside control doors for control circuit and power wiring information.

### CAUTION

When connecting electrical power and control wiring to the unit, water-proof connectors must be used so that water or moisture cannot be drawn into the unit during normal operation. The above water-proofing conditions will also apply when installing a field supplied disconnect switch.

**Convenience Outlet**

If a factory option convenience outlet is installed, the weatherproof outlet cover must be field installed. The cover shall be located behind the filter access panel. To install the cover, remove the convenience outlet shipping label located in the lower section of the control panel, and attach the cover to the unit using the (4) screws provided.

<p>208/230-3-60 and 380/415-3-50 units with factory installed Powered Convenience Outlet Option are wired for 230v and 415v power supply respectively. Change tap on transformer for 208-3-60 or 380-3-50 operation. See unit wiring diagram.</p>

**Power Wiring Detail**

Units are factory wired for the voltage shown on the unit nameplate. Refer to Electrical Data Table 7 to size power wiring, fuses, and disconnect switch.

Power wiring is brought into the unit through the side of the unit or the basepan inside the curb.

**Thermostat Wiring**

The thermostat should be located on an inside wall approximately 56 inch above the floor where it will not be subject to drafts, sun exposure or heat from electrical fixtures or appliances. Follow the manufacturer's instructions enclosed with thermostat for general installation procedure. Seven (7) color-coded, insulated wires should be used to connect the thermostat to the unit. Refer to Table 6 for control wire sizing and maximum length.

**Table 6: Control Wire Sizes**

Wire Size	Maximum Length <sup>1</sup>
18 AWG	150 Feet

1. From the unit to the thermostat and back to the unit.

### TYPICAL POWER WIRING

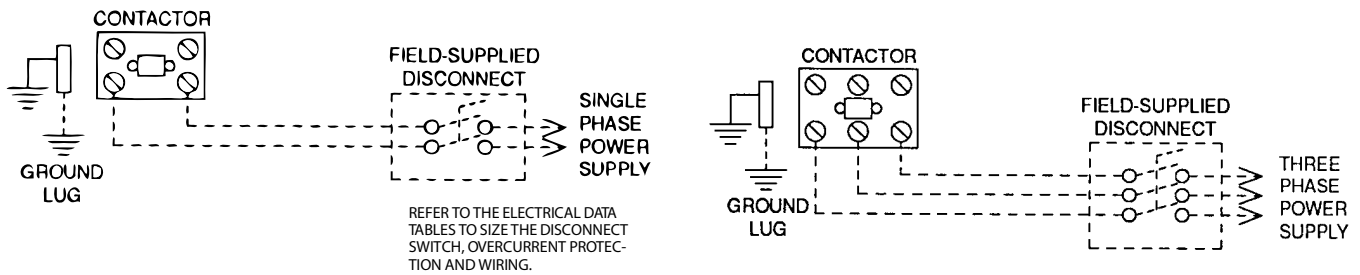

### TYPICAL CONTROL WIRING

#### COOLING ONLY (24 VOLT THERMOSTAT)

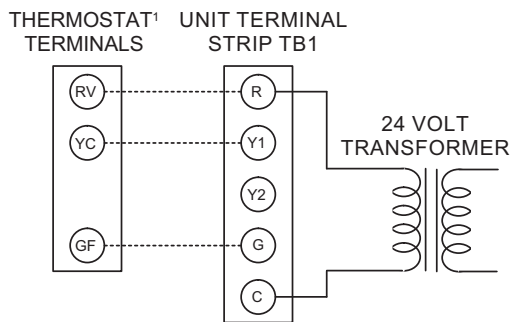

<sup>1</sup>24 VOLT THERMOSTAT 2TH07701024. TO CONTROL THE ECONOMIZER ON SECOND STAGE COOLING, USE THE THERMOSTAT 2TH0401224.

#### COOLING / HEATING (24 VOLT THERMOSTAT)

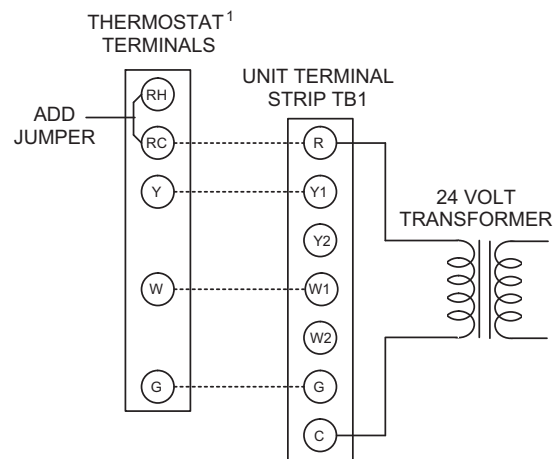

<sup>1</sup>24 VOLT THERMOSTAT 2ET07701024. TO CONTROL THE ECONOMIZER ON THE SECOND STAGE COOLING OR TO HAVE AN ELECTRIC HEAT ACCESSORY WITH TWO STAGES OF HEAT, USE THERMOSTAT 2TH0471024.

#### COOLING / HEATING (ELECTRONIC THERMOSTAT) MULTI STAGE

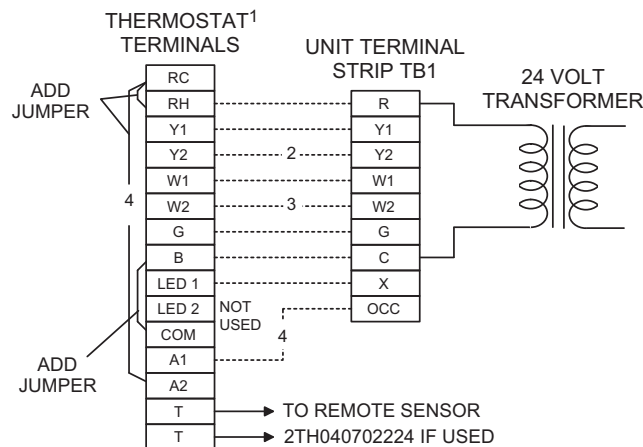

- <sup>1</sup> ELECTRONIC PROGRAMMABLE THERMOSTAT 2ET04700224 (INCLUDES SUBBASE).
- <sup>2</sup> SECOND STAGE COOLING IS NOT REQUIRED ON UNITS LESS ECONOMIZER.
- <sup>3</sup> SECOND STAGE HEATING IS ONLY REQUIRED ON UNITS WITH A TWO STAGE ELECTRIC HEATER OR 2 STAGE GAS HEAT.
- <sup>4</sup> REMOVE JUMPER J2 FROM TERMINALS 4 AND 9 ON JUMPER PLUG CONNECTOR P6 ON UNITS WITH ECONOMIZER. TERMINALS A1 AND A2 PROVIDE A RELAY OUTPUT-PUT TO CLOSE THE OUTDOOR ECONOMIZER DAMPERS WHEN THE THERMOSTAT SWITCHES TO THE SET-BACK POSITION.

#### COOLING / HEATING (ELECTRONIC THERMOSTAT) SINGLE STAGE

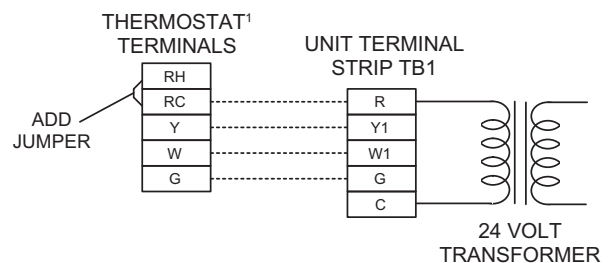

<sup>1</sup>ELECTRONIC PROGRAMMABLE THERMOSTAT 2ET07701024 (INCLUDES SUBBASE). TO CONTROL THE ECONOMIZER ON SECOND STAGE COOLING, USE THERMOSTAT 2TH04700224.

**Figure 13: Typical Field Power and Control Wiring**

**Table 7: Electrical Data**

**J03 thru 05ZF - Without Powered Convenience Outlet (Belt Drive)**

Size (Tons)	Volt	Compressors (each)			OD Fan Motors (each)	Supply Blower Motor	Pwr Conv Outlet	Electric Heat Option				MCA <sup>1</sup> (Amps)	Max Fuse <sup>2</sup> / Breaker <sup>3</sup> Size (Amps)					
		RLA	LRA	MCC	FLA	FLA	FLA	Model	kW	Stages	Amps							
J03 (3.0)	208-1-60	14.7	74.0	23.0	2.3	7.6	0.0	None	-	-	-	28.3	35					
								E05	4.0	1	19.2	33.5	40					
								E07	5.6	1	26.9	43.2	45					
								E10	8.0	1	38.5	57.6	60					
								E15	11.9	2	57.2	81.0	90					
								E20	15.9	2	76.4	105.1	110					
	230-1-60	14.7	74.0	23.0	2.3	7.6	0.0	None	-	-	-	28.3	35					
								E05	5.3	1	22.1	37.1	40					
								E07	7.5	1	31.3	48.6	50					
								E10	10.6	1	44.2	64.7	70					
								E15	15.9	2	66.3	92.3	100					
								E20	21.2	2	88.3	119.9	125					
	208-3-60	9.1	68.0	14.2	2.3	5.2	0.0	None	-	-	-	18.9	25					
								E05	4.0	1	11.1	20.4	25					
								E07	5.6	1	15.5	25.9	30					
								E10	8.0	1	22.2	34.3	35					
								E15	11.9	2	33.0	47.8	50					
								E20	15.9	2	44.1	61.7	70					
	230-3-60	9.1	68.0	14.2	2.3	5.2	0.0	None	-	-	-	18.9	25					
								E05	5.3	1	12.7	22.4	25					
								E07	7.5	1	18.0	29.1	30					
								E10	10.6	1	25.5	38.4	40					
								E15	15.9	2	38.2	54.3	60					
								E20	21.2	2	51.0	70.2	80					
460-3-60	4.5	34.0	7.0	1.3	2.6	0.0	None	-	-	-	9.5	15						
							E07	6.8	1	8.2	13.5	15						
							E10	10.1	1	12.1	18.4	20						
							E15	13.6	2	16.4	23.7	25						
							E20	19.5	2	23.5	32.6	35						
575-3-60	3.8	28.0	6.0	1.3	2.0	0.0	None	-	-	-	7.8	15						
							E10	10.6	1	10.2	15.2	20						
							E15	15.9	1	15.3	21.6	25						
							E20	21.2	2	20.4	28.0	30						
J04 (4.0)	208-1-60	15.7	84.0	24.5	2.3	7.6	0.0	None	-	-	-	29.5	40					
								E05	4.0	1	19.2	33.5	45					
								E07	5.6	1	26.9	43.2	45					
								E10	8.0	1	38.5	57.6	60					
								E15	11.9	2	57.2	81.0	90					
								E20	15.9	2	76.4	105.1	110					
	230-1-60	15.7	84.0	24.5	2.3	7.6	0.0	None	-	-	-	29.5	40					
								E05	5.3	1	22.1	37.1	45					
								E07	7.5	1	31.3	48.6	50					
								E10	10.6	1	44.2	64.7	70					
								E15	15.9	2	66.3	92.3	100					
								E20	21.2	2	88.3	119.9	125					
	208-3-60	11.2	88.0	17.5	2.3	5.2	0.0	None	-	-	-	21.5	30					
								E05	4.0	1	11.1	21.5	30					
								E07	5.6	1	15.5	25.9	30					
								E10	8.0	1	22.2	34.3	35					
								E15	11.9	2	33.0	47.8	50					
								E20	15.9	2	44.1	61.7	70					
	230-3-60	11.2	88.0	17.5	2.3	5.2	0.0	None	-	-	-	21.5	30					
								E05	5.3	1	12.7	22.4	30					
								E07	7.5	1	18.0	29.1	30					
								E10	10.6	1	25.5	38.4	40					
								E15	15.9	2	38.2	54.3	60					
								E20	21.2	2	51.0	70.2	80					
460-3-60	5.1	44.0	8.0	1.3	2.6	0.0	None	-	-	-	10.3	15						
							E07	6.8	1	8.2	13.5	15						
							E10	10.1	1	12.1	18.4	20						
							E15	13.6	2	16.4	23.7	25						
							E20	19.5	2	23.5	32.6	35						
575-3-60	4.5	36.0	7.0	1.3	2.0	0.0	None	-	-	-	8.7	15						
							E10	10.6	1	10.2	15.2	20						
							E15	15.9	1	15.3	21.6	25						
							E20	21.2	2	20.4	28.0	30						



## J03 thru 05ZF - Without Powered Convenience Outlet (Belt Drive) (Continued)

Size (Tons)	Volt	Compressors (each)			OD Fan Motors (each)	Supply Blower Motor	Pwr Conv Outlet	Electric Heat Option				MCA <sup>1</sup> (Amps)	Max Fuse <sup>2</sup> / Breaker <sup>3</sup> Size (Amps)
		RLA	LRA	MCC	FLA	FLA	FLA	Model	kW	Stages	Amps		
J05 (5.0)	208-1-60	21.1	105.0	33.0	2.3	7.6	0.0	None	-	-	-	36.3	45
								E05	4.0	1	19.2	36.3	45
								E07	5.6	1	26.9	43.2	50
								E10	8.0	1	38.5	57.6	60
								E15	11.9	2	57.2	81.0	90
								E20	15.9	2	76.4	105.1	110
	230-1-60	21.1	105.0	33.0	2.3	7.6	0.0	None	-	-	-	36.3	45
								E05	5.3	1	22.1	37.1	45
								E07	7.5	1	31.3	48.6	50
								E10	10.6	1	44.2	64.7	70
								E15	15.9	2	66.3	92.3	100
								E20	21.2	2	88.3	119.9	125
	208-3-60	14.1	88.0	22.0	2.3	5.2	0.0	None	-	-	-	25.1	35
								E05	4.0	1	11.1	25.1	35
								E07	5.6	1	15.5	25.9	35
								E10	8.0	1	22.2	34.3	35
								E15	11.9	2	33.0	47.8	50
								E20	15.9	2	44.1	61.7	70
	230-3-60	14.1	88.0	22.0	2.3	5.2	0.0	None	-	-	-	25.1	35
								E05	5.3	1	12.7	25.1	35
								E07	7.5	1	18.0	29.1	35
								E10	10.6	1	25.5	38.4	40
								E15	15.9	2	38.2	54.3	60
								E20	21.2	2	51.0	70.2	80
460-3-60	7.7	55.0	12.0	1.3	2.6	0.0	None	-	-	-	13.5	20	
							E07	6.8	1	8.2	13.5	20	
							E10	10.1	1	12.1	18.4	20	
							E15	13.6	2	16.4	23.7	25	
							E20	19.5	2	23.5	32.6	35	
							E30	28.8	2	34.6	46.6	50	
575-3-60	4.8	36.0	7.5	1.3	2.0	0.0	None	-	-	-	9.0	15	
							E10	10.6	1	10.2	15.2	20	
							E15	15.9	1	15.3	21.6	25	
							E20	21.2	2	20.4	28.0	30	
							E30	30.4	2	29.3	39.1	40	

1. Minimum Circuit Ampacity.
2. Dual Element, Time Delay Type.
3. HACR type per NEC.

**JA6ZF Without Powered Convenience Outlet (Belt Drive) Cooling With/Without Electric Heat**

Size (Tons)	Volt	Compressors (each)			OD Fan Motors (each)	Supply Blower Motor	Pwr Conv Outlet	Electric Heat Option				MCA <sup>1</sup> (Amps)	Max Fuse <sup>2</sup> / Breaker <sup>3</sup> Size (Amps)
		RLA	LRA	MCC	FLA	FLA	FLA	Model	kW	Stages	Amps		
JA6 (6.0)	208-3-60	19.0	123.0	29.7	5.3	5.2	0.0	None	-	-	-	34.3	45
								E05	4.0	1	11.1	34.3	45
								E07	5.6	1	15.5	34.3	45
								E10	8.0	1	22.2	34.3	45
								E15	11.9	2	33.0	47.8	50
								E20	15.9	2	44.1	61.7	70
	230-3-60	19.0	123.0	29.7	5.3	5.2	0.0	None	-	-	-	34.3	45
								E05	5.3	1	12.7	34.3	45
								E07	7.5	1	18.0	34.3	45
								E10	10.6	1	25.5	38.4	50
								E15	15.9	2	38.2	54.3	60
								E20	21.2	2	51.0	70.2	80
	460-3-60	9.7	62.0	15.2	5.3	2.6	0.0	None	-	-	-	17.4	25
								E07	6.8	1	8.2	17.4	25
								E10	10.1	1	12.1	18.4	25
								E15	13.6	2	16.4	23.7	25
								E20	19.5	2	23.5	32.6	35
								E30	28.8	2	34.6	46.6	50
	575-3-60	7.4	50.0	11.6	5.3	2.0	0.0	None	-	-	-	13.4	15
								E10	10.6	1	10.2	15.2	20
								E15	15.9	1	15.3	21.6	25
								E20	21.2	2	20.4	28.0	30
								E30	30.4	2	29.3	39.1	40

1. Minimum Circuit Ampacity.
2. Dual Element, Time Delay Type.
3. HACR type per NEC.

**JA6ZF Without Powered Convenience Outlet (Belt Drive) Cooling With Gas Heat**

Size (Tons)	Volt	Compressors (each)			OD Fan Motors (each)	Supply Blower Motor	Pwr Conv Outlet	MCA <sup>1</sup> (Amps)	Max Fuse <sup>2</sup> / Breaker <sup>3</sup> Size (Amps)
		RLA	LRA	MCC	FLA	FLA	FLA		
JA6 (6.0)	208-3-60	19.0	123.0	29.7	2.3	5.2	0.0	31.3	40.0
	230-3-60								
	460-3-60								
	575-3-60								

1. Minimum Circuit Ampacity.
2. Dual Element, Time Delay Type.
3. HACR type per NEC.

## J03 thru 05ZF Without Powered Convenience Outlet (Belt Drive High Static)

Size (Tons)	Volt	Compressors (each)			OD Fan Motors (each)	Supply Blower Motor	Pwr Conv Outlet	Electric Heat Option				MCA <sup>1</sup> (Amps)	Max Fuse <sup>2</sup> / Breaker <sup>3</sup> Size (Amps)
		RLA	LRA	MCC	FLA	FLA	FLA	Model	kW	Stages	Amps		
J03 (3.0)	208-1-60	14.7	74.0	23.0	2.3	7.6	0.0	None	-	-	-	28.3	35
								E05	4.0	1	19.2	33.5	40
								E07	5.6	1	26.9	43.2	45
								E10	8.0	1	38.5	57.6	60
								E15	11.9	2	57.2	81.0	90
	230-1-60	14.7	74.0	23.0	2.3	7.6	0.0	E20	15.9	2	76.4	105.1	110
								None	-	-	-	28.3	35
								E05	5.3	1	22.1	37.1	40
								E07	7.5	1	31.3	48.6	50
								E10	10.6	1	44.2	64.7	70
	208-3-60	9.1	68.0	14.2	2.3	5.2	0.0	E15	15.9	2	66.3	92.3	100
								E20	21.2	2	88.3	119.9	125
								None	-	-	-	18.9	25
								E05	4.0	1	11.1	20.4	25
								E07	5.6	1	15.5	25.9	30
	230-3-60	9.1	68.0	14.2	2.3	5.2	0.0	E10	8.0	1	22.2	34.3	35
								E15	11.9	2	33.0	47.8	50
								E20	15.9	2	44.1	61.7	70
								None	-	-	-	18.9	25
								E05	5.3	1	12.7	22.4	25
	460-3-60	4.5	34.0	7.0	1.3	2.6	0.0	E07	7.5	1	18.0	29.1	30
								E10	10.6	1	25.5	38.4	40
								E15	15.9	2	38.2	54.3	60
								E20	21.2	2	51.0	70.2	80
None								-	-	-	9.5	15	
575-3-60	3.8	28.0	6.0	1.3	2.0	0.0	E07	6.8	1	8.2	13.5	15	
							E10	10.1	1	12.1	18.4	20	
							E15	13.6	2	16.4	23.7	25	
							E20	19.5	2	23.5	32.6	35	
							None	-	-	-	7.8	15	
J04 (4.0)	208-1-60	15.7	84.0	24.5	2.3	7.6	0.0	E10	10.6	1	10.2	15.2	20
								E15	15.9	1	15.3	21.6	25
								E20	21.2	2	20.4	28.0	30
								None	-	-	-	29.5	40
								E05	4.0	1	19.2	33.5	45
	230-1-60	15.7	84.0	24.5	2.3	7.6	0.0	E07	5.6	1	26.9	43.2	45
								E10	8.0	1	38.5	57.6	60
								E15	11.9	2	57.2	81.0	90
								E20	15.9	2	76.4	105.1	110
								None	-	-	-	29.5	40
	208-3-60	11.2	88.0	17.5	2.3	5.2	0.0	E05	5.3	1	22.1	37.1	45
								E07	7.5	1	31.3	48.6	50
								E10	10.6	1	44.2	64.7	70
								E15	15.9	2	66.3	92.3	100
								E20	21.2	2	88.3	119.9	125
	230-3-60	11.2	88.0	17.5	2.3	5.2	0.0	None	-	-	-	21.5	30
								E05	4.0	1	11.1	21.5	30
								E07	5.6	1	15.5	25.9	30
								E10	8.0	1	22.2	34.3	35
								E15	11.9	2	33.0	47.8	50
	460-3-60	5.1	44.0	8.0	1.3	2.6	0.0	E20	15.9	2	44.1	61.7	70
								None	-	-	-	10.3	15
								E07	6.8	1	8.2	13.5	15
								E10	10.1	1	12.1	18.4	20
E15								13.6	2	16.4	23.7	25	
575-3-60	4.5	36.0	7.0	1.3	2.0	0.0	E20	19.5	2	23.5	32.6	35	
							None	-	-	-	8.7	15	
							E10	10.6	1	10.2	15.2	20	
							E15	15.9	1	15.3	21.6	25	
							E20	21.2	2	20.4	28.0	30	

**J03 thru 05ZF Without Powered Convenience Outlet (Belt Drive High Static) (Continued)**

Size (Tons)	Volt	Compressors (each)			OD Fan Motors (each)	Supply Blower Motor	Pwr Conv Outlet	Electric Heat Option				MCA <sup>1</sup> (Amps)	Max Fuse <sup>2</sup> / Breaker <sup>3</sup> Size (Amps)
		RLA	LRA	MCC	FLA	FLA	FLA	Model	kW	Stages	Amps		
J05 (5.0)	208-3-60	14.1	88.0	22.0	2.3	8.2	0.0	None	-	-	-	28.1	35
								E05	4.0	1	11.1	28.1	35
								E07	5.6	1	15.5	29.7	40
								E10	8.0	1	22.2	38.0	40
								E15	11.9	2	33.0	51.5	60
								E20	15.9	2	44.1	65.4	70
	230-3-60	14.1	88.0	22.0	2.3	8.2	0.0	None	-	-	-	28.1	35
								E05	5.3	1	12.7	28.1	35
								E07	7.5	1	18.0	32.8	40
								E10	10.6	1	25.5	42.1	45
								E15	15.9	2	38.2	58.1	60
								E20	21.2	2	51.0	74.0	80
	460-3-60	7.7	55.0	12.0	1.3	4.1	0.0	None	-	-	-	15.0	20
								E07	6.8	1	8.2	15.3	20
								E10	10.1	1	12.1	20.3	25
								E15	13.6	2	16.4	25.6	30
								E20	19.5	2	23.5	34.4	35
								E30	28.8	2	34.6	48.4	50
	575-3-60	4.8	36.0	7.5	1.3	3.6	0.0	None	-	-	-	10.6	15
								E10	10.6	1	10.2	17.2	20
E15								15.9	1	15.3	23.6	25	
E20								21.2	2	20.4	30.0	30	
E30								30.4	2	29.3	41.1	45	

1. Minimum Circuit Ampacity.
2. Dual Element, Time Delay Type.
3. HACR type per NEC.

**JA6ZF Without Powered Convenience Outlet (Belt Drive High Static) Cooling With/Without Electric Heat**

Size (Tons)	Volt	Compressors (each)			OD Fan Motors (each)	Supply Blower Motor	Pwr Conv Outlet	Electric Heat Option				MCA <sup>1</sup> (Amps)	Max Fuse <sup>2</sup> / Breaker <sup>3</sup> Size (Amps)
		RLA	LRA	MCC	FLA	FLA	FLA	Model	kW	Stages	Amps		
JA6 (6.0)	208-3-60	19.0	123.0	29.7	5.3	10.9	0.0	None	-	-	-	40.0	50
								E05	4.0	1	11.1	40.0	50
								E07	5.6	1	15.5	40.0	50
								E10	8.0	1	22.2	41.4	50
								E15	11.9	2	33.0	54.9	60
								E20	15.9	2	44.1	68.8	70
	230-3-60	19.0	123.0	29.7	5.3	10.9	0.0	None	-	-	-	40.0	50
								E05	5.3	1	12.7	40.0	50
								E07	7.5	1	18.0	40.0	50
								E10	10.6	1	25.5	45.5	50
								E15	15.9	2	38.2	61.4	70
								E20	21.2	2	51.0	77.4	80
	460-3-60	9.7	62.0	15.2	5.3	5.3	0.0	None	-	-	-	20.1	25
								E07	6.8	1	8.2	20.1	25
								E10	10.1	1	12.1	21.8	25
								E15	13.6	2	16.4	27.1	30
								E20	19.5	2	23.5	35.9	40
								E30	28.8	2	34.6	49.9	50
	575-3-60	7.4	50.0	11.6	5.3	4.1	0.0	None	-	-	-	15.5	20
								E10	10.6	1	10.2	17.9	20
								E15	15.9	1	15.3	24.2	25
								E20	21.2	2	20.4	30.6	35
								E30	30.4	2	29.3	41.7	45

1. Minimum Circuit Ampacity.
2. Dual Element, Time Delay Type.
3. HACR type per NEC.

**JA6ZF Without Powered Convenience Outlet (Belt Drive High Static) Cooling With Gas Heat**

Size (Tons)	Volt	Compressors (each)			OD Fan Motors (each)	Supply Blower Motor	Pwr Conv Outlet	MCA <sup>1</sup> (Amps)	Max Fuse <sup>2</sup> / Breaker <sup>3</sup> Size (Amps)
		RLA	LRA	MCC	FLA	FLA	FLA		
JA6 (6.0)	208-3-60	19.0	123.0	29.7	2.3	10.9	0.0	37.0	50.0
	230-3-60								
	460-3-60								
	575-3-60								

1. Minimum Circuit Ampacity.
2. Dual Element, Time Delay Type.
3. HACR type per NEC.

**J03 thru 05ZF Without Powered Convenience Outlet (Direct Drive)**

Size (Tons)	Volt	Compressors (each)			OD Fan Motors (each)	Supply Blower Motor	Pwr Conv Outlet	Electric Heat Option				MCA <sup>1</sup> (Amps)	Max Fuse <sup>2</sup> / Breaker <sup>3</sup> Size (Amps)
		RLA	LRA	MCC	FLA	FLA	FLA	Model	kW	Stages	Amps		
J03 (3.0)	208-1-60	14.7	74.0	23.0	2.3	6.0	0.0	None	-	-	-	26.7	35
								E05	4.0	1	19.2	31.5	40
								E07	5.6	1	26.9	41.2	45
								E10	8.0	1	38.5	55.6	60
								E15	11.9	2	57.2	79.0	80
	E20	15.9	2	76.4	103.1	110							
	230-1-60	14.7	74.0	23.0	2.3	6.0	0.0	None	-	-	-	26.7	35
								E05	5.3	1	22.1	35.1	40
								E07	7.5	1	31.3	46.6	50
								E10	10.6	1	44.2	62.7	70
								E15	15.9	2	66.3	90.3	100
	E20	21.2	2	88.3	117.9	125							
	208-3-60	9.1	68.0	14.2	2.3	6.0	0.0	None	-	-	-	19.7	25
								E05	4.0	1	11.1	21.4	25
								E07	5.6	1	15.5	26.9	30
								E10	8.0	1	22.2	35.3	40
								E15	11.9	2	33.0	48.8	50
	E20	15.9	2	44.1	62.7	70							
	230-3-60	9.1	68.0	14.2	2.3	6.0	0.0	None	-	-	-	19.7	25
								E05	5.3	1	12.7	23.4	25
E07								7.5	1	18.0	30.1	35	
E10								10.6	1	25.5	39.4	40	
E15								15.9	2	38.2	55.3	60	
E20	21.2	2	51.0	71.2	80								
J04 (4.0)	208-1-60	15.7	84.0	24.5	2.3	7.6	0.0	None	-	-	-	29.5	40
								E05	4.0	1	19.2	33.5	45
								E07	5.6	1	26.9	43.2	45
								E10	8.0	1	38.5	57.6	60
								E15	11.9	2	57.2	81.0	90
	E20	15.9	2	76.4	105.1	110							
	230-1-60	15.7	84.0	24.5	2.3	7.6	0.0	None	-	-	-	29.5	40
								E05	5.3	1	22.1	37.1	45
								E07	7.5	1	31.3	48.6	50
								E10	10.6	1	44.2	64.7	70
								E15	15.9	2	66.3	92.3	100
	E20	21.2	2	88.3	119.9	125							
	208-3-60	11.2	88.0	17.5	2.3	7.6	0.0	None	-	-	-	23.9	30
								E05	4.0	1	11.1	23.9	30
								E07	5.6	1	15.5	28.9	35
								E10	8.0	1	22.2	37.3	40
								E15	11.9	2	33.0	50.8	60
	E20	15.9	2	44.1	64.7	70							
	230-3-60	11.2	88.0	17.5	2.3	7.6	0.0	None	-	-	-	23.9	30
								E05	5.3	1	12.7	25.4	35
E07								7.5	1	18.0	32.1	35	
E10								10.6	1	25.5	41.4	45	
E15								15.9	2	38.2	57.3	60	
E20	21.2	2	51.0	73.2	80								

## J03 thru 05ZF Without Powered Convenience Outlet (Direct Drive) (Continued)

Size (Tons)	Volt	Compressors (each)			OD Fan Motors (each)	Supply Blower Motor	Pwr Conv Outlet	Electric Heat Option				MCA <sup>1</sup> (Amps)	Max Fuse <sup>2</sup> / Breaker <sup>3</sup> Size (Amps)
		RLA	LRA	MCC	FLA	FLA	FLA	Model	kW	Stages	Amps		
J05 (5.0)	208-1-60	21.1	105.0	33.0	2.3	7.6	0.0	None	-	-	-	36.3	45
								E05	4.0	1	19.2	36.3	45
								E07	5.6	1	26.9	43.2	50
								E10	8.0	1	38.5	57.6	60
								E15	11.9	2	57.2	81.0	90
								E20	15.9	2	76.4	105.1	110
	230-1-60	21.1	105.0	33.0	2.3	7.6	0.0	None	-	-	-	36.3	45
								E05	5.3	1	22.1	37.1	45
								E07	7.5	1	31.3	48.6	50
								E10	10.6	1	44.2	64.7	70
								E15	15.9	2	66.3	92.3	100
								E20	21.2	2	88.3	119.9	125
	208-3-60	14.1	88.0	22.0	2.3	7.6	0.0	None	-	-	-	27.5	35
								E05	4.0	1	11.1	27.5	35
								E07	5.6	1	15.5	28.9	35
								E10	8.0	1	22.2	37.3	40
								E15	11.9	2	33.0	50.8	60
								E20	15.9	2	44.1	64.7	70
	230-3-60	14.1	88.0	22.0	2.3	7.6	0.0	None	-	-	-	27.5	35
								E05	5.3	1	12.7	27.5	35
								E07	7.5	1	18.0	32.1	40
								E10	10.6	1	25.5	41.4	45
								E15	15.9	2	38.2	57.3	60
								E20	21.2	2	51.0	73.2	80
							E30	29.6	2	71.2	98.5	100	

1. Minimum Circuit Ampacity.
2. Dual Element, Time Delay Type.
3. HACR type per NEC.

**JA6ZF Without Powered Convenience Outlet (Direct Drive) Cooling With/Without Electric Heat**

Size (Tons)	Volt	Compressors (each)			OD Fan Motors (each)	Supply Blower Motor	Pwr Conv Outlet	Electric Heat Option				MCA <sup>1</sup> (Amps)	Max Fuse <sup>2</sup> / Breaker <sup>3</sup> Size (Amps)
		RLA	LRA	MCC	FLA	FLA	FLA	Model	kW	Stages	Amps		
JA6 (6.0)	208-3-60	19.0	123.0	29.7	5.3	7.6	0.0	None	-	-	-	36.7	50
								E05	4.0	1	11.1	36.7	50
								E07	5.6	1	15.5	36.7	50
								E10	8.0	1	22.2	37.3	50
								E15	11.9	2	33.0	50.8	60
								E20	15.9	2	44.1	64.7	70
								E30	22.2	2	61.6	86.5	90
	230-3-60	19.0	123.0	29.7	5.3	7.6	0.0	None	-	-	-	36.7	50
								E05	5.3	1	12.7	36.7	50
								E07	7.5	1	18.0	36.7	50
								E10	10.6	1	25.5	41.4	50
								E15	15.9	2	38.2	57.3	60
								E20	21.2	2	51.0	73.2	80
								E30	29.6	2	71.2	98.5	100

1. Minimum Circuit Ampacity.
2. Dual Element, Time Delay Type.
3. HACR type per NEC.

**JA6ZF Without Powered Convenience Outlet (Direct Drive) Cooling With Gas Heat**

Size (Tons)	Volt	Compressors (each)			OD Fan Motors (each)	Supply Blower Motor	Pwr Conv Outlet	MCA <sup>1</sup> (Amps)	Max Fuse <sup>2</sup> / Breaker <sup>3</sup> Size (Amps)
		RLA	LRA	MCC	FLA	FLA	FLA		
JA6 (6.0)	208-3-60 230-3-60	19.0	123.0	29.7	2.3	7.6	0.0	33.7	45.0

1. Minimum Circuit Ampacity.
2. Dual Element, Time Delay Type.
3. HACR type per NEC.



**J03 thru 05ZF - With Powered Convenience Outlet (Belt Drive)**

Size (Tons)	Volt	Compressors (each)			OD Fan Motors (each)	Supply Blower Motor	Pwr Conv Outlet	Electric Heat Option				MCA <sup>1</sup> (Amps)	Max Fuse <sup>2/</sup> Breaker <sup>3</sup> Size (Amps)
		RLA	LRA	MCC	FLA	FLA	FLA	Model	kW	Stages	Amps		
J03 (3.0)	208-1-60	14.7	74.0	23.0	2.3	7.6	10.0	None	-	-	-	38.3	50
								E05	4.0	1	19.2	46.0	50
								E07	5.6	1	26.9	55.7	60
								E10	8.0	1	38.5	70.1	80
								E15	11.9	2	57.2	93.5	100
								E20	15.9	2	76.4	117.6	125
	230-1-60	14.7	74.0	23.0	2.3	7.6	10.0	None	-	-	-	38.3	50
								E05	5.3	1	22.1	49.6	50
								E07	7.5	1	31.3	61.1	70
								E10	10.6	1	44.2	77.2	80
								E15	15.9	2	66.3	104.8	110
								E20	21.2	2	88.3	132.4	150
	208-3-60	9.1	68.0	14.2	2.3	5.2	10.0	None	-	-	-	29.1	35
								E05	4.0	1	11.1	32.9	35
								E07	5.6	1	15.5	38.4	40
								E10	8.0	1	22.2	46.8	50
								E15	11.9	2	33.0	60.3	70
								E20	15.9	2	44.1	74.2	80
	230-3-60	9.1	68.0	14.2	2.3	5.2	10.0	None	-	-	-	29.1	35
								E05	5.3	1	12.7	34.9	40
								E07	7.5	1	18.0	41.6	45
								E10	10.6	1	25.5	50.9	60
								E15	15.9	2	38.2	66.8	70
								E20	21.2	2	51.0	82.7	90
460-3-60	4.5	34.0	7.0	1.3	2.6	5.0	None	-	-	-	14.6	15	
							E07	6.8	1	8.2	19.7	20	
							E10	10.1	1	12.1	24.7	25	
							E15	13.6	2	16.4	29.9	30	
							E20	19.5	2	23.5	38.8	40	
575-3-60	3.8	28.0	6.0	1.3	2.0	4.0	None	-	-	-	11.8	15	
							E10	10.6	1	10.2	20.2	25	
							E15	15.9	1	15.3	26.6	30	
							E20	21.2	2	20.4	33.0	35	
J04 (4.0)	208-1-60	15.7	84.0	24.5	2.3	7.6	10.0	None	-	-	-	39.5	50
								E05	4.0	1	19.2	46.0	50
								E07	5.6	1	26.9	55.7	60
								E10	8.0	1	38.5	70.1	80
								E15	11.9	2	57.2	93.5	100
								E20	15.9	2	76.4	117.6	125
	230-1-60	15.7	84.0	24.5	2.3	7.6	10.0	None	-	-	-	39.5	50
								E05	5.3	1	22.1	49.6	50
								E07	7.5	1	31.3	61.1	70
								E10	10.6	1	44.2	77.2	80
								E15	15.9	2	66.3	104.8	110
								E20	21.2	2	88.3	132.4	150
	208-3-60	11.2	88.0	17.5	2.3	5.2	10.0	None	-	-	-	31.5	40
								E05	4.0	1	11.1	32.9	40
								E07	5.6	1	15.5	38.4	40
								E10	8.0	1	22.2	46.8	50
								E15	11.9	2	33.0	60.3	70
								E20	15.9	2	44.1	74.2	80
	230-3-60	11.2	88.0	17.5	2.3	5.2	10.0	None	-	-	-	31.5	40
								E05	5.3	1	12.7	34.9	40
								E07	7.5	1	18.0	41.6	45
								E10	10.6	1	25.5	50.9	60
								E15	15.9	2	38.2	66.8	70
								E20	21.2	2	51.0	82.7	90
460-3-60	5.1	44.0	8.0	1.3	2.6	5.0	None	-	-	-	15.3	20	
							E07	6.8	1	8.2	19.7	20	
							E10	10.1	1	12.1	24.7	25	
							E15	13.6	2	16.4	29.9	30	
							E20	19.5	2	23.5	38.8	40	
575-3-60	4.5	36.0	7.0	1.3	2.0	4.0	None	-	-	-	12.7	15	
							E10	10.6	1	10.2	20.2	25	
							E15	15.9	1	15.3	26.6	30	
							E20	21.2	2	20.4	33.0	35	

**J03 thru 05ZF - With Powered Convenience Outlet (Belt Drive) (Continued)**

Size (Tons)	Volt	Compressors (each)			OD Fan Motors (each)	Supply Blower Motor	Pwr Conv Outlet	Electric Heat Option				MCA <sup>1</sup> (Amps)	Max Fuse <sup>2/</sup> Breaker <sup>3</sup> Size (Amps)
		RLA	LRA	MCC	FLA	FLA	FLA	Model	kW	Stages	Amps		
J05 (5.0)	208-1-60	21.1	105.0	33.0	2.3	7.6	10.0	None	-	-	-	46.3	60
								E05	4.0	1	19.2	46.3	60
								E07	5.6	1	26.9	55.7	60
								E10	8.0	1	38.5	70.1	80
								E15	11.9	2	57.2	93.5	100
								E20	15.9	2	76.4	117.6	125
	230-1-60	21.1	105.0	33.0	2.3	7.6	10.0	None	-	-	-	46.3	60
								E05	5.3	1	22.1	49.6	60
								E07	7.5	1	31.3	61.1	70
								E10	10.6	1	44.2	77.2	80
								E15	15.9	2	66.3	104.8	110
								E20	21.2	2	88.3	132.4	150
	208-3-60	14.1	88.0	22.0	2.3	5.2	10.0	None	-	-	-	35.1	45
								E05	4.0	1	11.1	35.1	45
								E07	5.6	1	15.5	38.4	45
								E10	8.0	1	22.2	46.8	50
								E15	11.9	2	33.0	60.3	70
								E20	15.9	2	44.1	74.2	80
	230-3-60	14.1	88.0	22.0	2.3	5.2	10.0	None	-	-	-	35.1	45
								E05	5.3	1	12.7	35.1	45
								E07	7.5	1	18.0	41.6	45
								E10	10.6	1	25.5	50.9	60
								E15	15.9	2	38.2	66.8	70
								E20	21.2	2	51.0	82.7	90
460-3-60	7.7	55.0	12.0	1.3	2.6	5.0	None	-	-	-	18.5	25	
							E07	6.8	1	8.2	19.7	25	
							E10	10.1	1	12.1	24.7	25	
							E15	13.6	2	16.4	29.9	30	
							E20	19.5	2	23.5	38.8	40	
							E30	28.8	2	34.6	52.8	60	
575-3-60	4.8	36.0	7.5	1.3	2.0	4.0	None	-	-	-	13.0	15	
							E10	10.6	1	10.2	20.2	25	
							E15	15.9	1	15.3	26.6	30	
							E20	21.2	2	20.4	33.0	35	
							E30	30.4	2	29.3	44.1	45	

1. Minimum Circuit Ampacity.
2. Dual Element, Time Delay Type.
3. HACR type per NEC.

**JA6ZF With Powered Convenience Outlet (Belt Drive) Cooling With/Without Electric Heat**

Size (Tons)	Volt	Compressors (each)			OD Fan Motors (each)	Supply Blower Motor	Pwr Conv Outlet	Electric Heat Option				MCA <sup>1</sup> (Amps)	Max Fuse <sup>2</sup> / Breaker <sup>3</sup> Size (Amps)
		RLA	LRA	MCC	FLA	FLA	FLA	Model	kW	Stages	Amps		
JA6 (6.0)	208-3-60	19.0	123.0	29.7	5.3	5.2	10.0	None	-	-	-	44.3	60
								E05	4.0	1	11.1	44.3	60
								E07	5.6	1	15.5	44.3	60
								E10	8.0	1	22.2	46.8	60
								E15	11.9	2	33.0	60.3	70
								E20	15.9	2	44.1	74.2	80
	230-3-60	19.0	123.0	29.7	5.3	5.2	10.0	None	-	-	-	44.3	60
								E05	5.3	1	12.7	44.3	60
								E07	7.5	1	18.0	44.3	60
								E10	10.6	1	25.5	50.9	60
								E15	15.9	2	38.2	66.8	70
								E20	21.2	2	51.0	82.7	90
	460-3-60	9.7	62.0	15.2	5.3	2.6	5.0	None	-	-	-	22.4	30
								E07	6.8	1	8.2	22.4	30
								E10	10.1	1	12.1	24.7	30
								E15	13.6	2	16.4	29.9	30
								E20	19.5	2	23.5	38.8	40
								E30	28.8	2	34.6	52.8	60
	575-3-60	7.4	50.0	11.6	5.3	2.0	4.0	None	-	-	-	17.4	20
								E10	10.6	1	10.2	20.2	25
								E15	15.9	1	15.3	26.6	30
								E20	21.2	2	20.4	33.0	35
								E30	30.4	2	29.3	44.1	45

1. Minimum Circuit Ampacity.
2. Dual Element, Time Delay Type.
3. HACR type per NEC.

**JA6ZF With Powered Convenience Outlet (Belt Drive) Cooling With Gas Heat**

Size (Tons)	Volt	Compressors (each)			OD Fan Motors (each)	Supply Blower Motor	Pwr Conv Outlet	MCA <sup>1</sup> (Amps)	Max Fuse <sup>2</sup> / Breaker <sup>3</sup> Size (Amps)
		RLA	LRA	MCC	FLA	FLA	FLA		
JA6 (6.0)	208-3-60	19.0	123.0	29.7	2.3	5.2	10.0	41.3	60.0
	230-3-60								
	460-3-60								
	575-3-60								

1. Minimum Circuit Ampacity.
2. Dual Element, Time Delay Type.
3. HACR type per NEC.

**J03 thru 05ZF With Powered Convenience Outlet (Belt Drive High Static)**

Size (Tons)	Volt	Compressors (each)			OD Fan Motors (each)	Supply Blower Motor	Pwr Conv Outlet	Electric Heat Option				MCA <sup>1</sup> (Amps)	Max Fuse <sup>2/</sup> Breaker <sup>3</sup> Size (Amps)
		RLA	LRA	MCC	FLA	FLA	FLA	Model	kW	Stages	Amps		
J03 (3.0)	208-1-60	14.7	74.0	23.0	2.3	7.6	10.0	None	-	-	-	38.3	50
								E05	4.0	1	19.2	46.0	50
								E07	5.6	1	26.9	55.7	60
								E10	8.0	1	38.5	70.1	80
								E15	11.9	2	57.2	93.5	100
								E20	15.9	2	76.4	117.6	125
	230-1-60	14.7	74.0	23.0	2.3	7.6	10.0	None	-	-	-	38.3	50
								E05	5.3	1	22.1	49.6	50
								E07	7.5	1	31.3	61.1	70
								E10	10.6	1	44.2	77.2	80
								E15	15.9	2	66.3	104.8	110
								E20	21.2	2	88.3	132.4	150
	208-3-60	9.1	68.0	14.2	2.3	5.2	10.0	None	-	-	-	29.1	35
								E05	4.0	1	11.1	32.9	35
								E07	5.6	1	15.5	38.4	40
								E10	8.0	1	22.2	46.8	50
								E15	11.9	2	33.0	60.3	70
								E20	15.9	2	44.1	74.2	80
	230-3-60	9.1	68.0	14.2	2.3	5.2	10.0	None	-	-	-	29.1	35
								E05	5.3	1	12.7	34.9	40
								E07	7.5	1	18.0	41.6	45
								E10	10.6	1	25.5	50.9	60
								E15	15.9	2	38.2	66.8	70
								E20	21.2	2	51.0	82.7	90
460-3-60	4.5	34.0	7.0	1.3	2.6	5.0	None	-	-	-	14.6	15	
							E07	6.8	1	8.2	19.7	20	
							E10	10.1	1	12.1	24.7	25	
							E15	13.6	2	16.4	29.9	30	
							E20	19.5	2	23.5	38.8	40	
575-3-60	3.8	28.0	6.0	1.3	2.0	4.0	None	-	-	-	11.8	15	
							E10	10.6	1	10.2	20.2	25	
							E15	15.9	1	15.3	26.6	30	
							E20	21.2	2	20.4	33.0	35	
J04 (4.0)	208-1-60	15.7	84.0	24.5	2.3	7.6	10.0	None	-	-	-	39.5	50
								E05	4.0	1	19.2	46.0	50
								E07	5.6	1	26.9	55.7	60
								E10	8.0	1	38.5	70.1	80
								E15	11.9	2	57.2	93.5	100
								E20	15.9	2	76.4	117.6	125
	230-1-60	15.7	84.0	24.5	2.3	7.6	10.0	None	-	-	-	39.5	50
								E05	5.3	1	22.1	49.6	50
								E07	7.5	1	31.3	61.1	70
								E10	10.6	1	44.2	77.2	80
								E15	15.9	2	66.3	104.8	110
								E20	21.2	2	88.3	132.4	150
	208-3-60	11.2	88.0	17.5	2.3	5.2	10.0	None	-	-	-	31.5	40
								E05	4.0	1	11.1	32.9	40
								E07	5.6	1	15.5	38.4	40
								E10	8.0	1	22.2	46.8	50
								E15	11.9	2	33.0	60.3	70
								E20	15.9	2	44.1	74.2	80
	230-3-60	11.2	88.0	17.5	2.3	5.2	10.0	None	-	-	-	31.5	40
								E05	5.3	1	12.7	34.9	40
								E07	7.5	1	18.0	41.6	45
								E10	10.6	1	25.5	50.9	60
								E15	15.9	2	38.2	66.8	70
								E20	21.2	2	51.0	82.7	90
	460-3-60	5.1	44.0	8.0	1.3	2.6	5.0	None	-	-	-	15.3	20
								E07	6.8	1	8.2	19.7	20
								E10	10.1	1	12.1	24.7	25
								E15	13.6	2	16.4	29.9	30
								E20	19.5	2	23.5	38.8	40
	575-3-60	4.5	36.0	7.0	1.3	2.0	4.0	None	-	-	-	12.7	15
E10								10.6	1	10.2	20.2	25	
E15								15.9	1	15.3	26.6	30	
E20								21.2	2	20.4	33.0	35	

## J03 thru 05ZF With Powered Convenience Outlet (Belt Drive High Static) (Continued)

Size (Tons)	Volt	Compressors (each)			OD Fan Motors (each)	Supply Blower Motor	Pwr Conv Outlet	Electric Heat Option				MCA <sup>1</sup> (Amps)	Max Fuse <sup>2/</sup> Breaker <sup>3</sup> Size (Amps)
		RLA	LRA	MCC	FLA	FLA	FLA	Model	kW	Stages	Amps		
J05 (5.0)	208-3-60	14.1	88.0	22.0	2.3	8.2	10.0	None	-	-	-	38.1	50
								E05	4.0	1	11.1	38.1	50
								E07	5.6	1	15.5	42.2	50
								E10	8.0	1	22.2	50.5	60
								E15	11.9	2	33.0	64.0	70
								E20	15.9	2	44.1	77.9	80
	230-3-60	14.1	88.0	22.0	2.3	8.2	10.0	None	-	-	-	38.1	50
								E05	5.3	1	12.7	38.7	50
								E07	7.5	1	18.0	45.3	50
								E10	10.6	1	25.5	54.6	60
								E15	15.9	2	38.2	70.6	80
								E20	21.2	2	51.0	86.5	90
	460-3-60	7.7	55.0	12.0	1.3	4.1	5.0	None	-	-	-	20.0	25
								E07	6.8	1	8.2	21.6	25
								E10	10.1	1	12.1	26.6	30
								E15	13.6	2	16.4	31.8	35
								E20	19.5	2	23.5	40.7	45
								E30	28.8	2	34.6	54.7	60
	575-3-60	4.8	36.0	7.5	1.3	3.6	4.0	None	-	-	-	14.6	15
								E10	10.6	1	10.2	22.2	25
								E15	15.9	1	15.3	28.6	30
								E20	21.2	2	20.4	35.0	35
								E30	30.4	2	29.3	46.1	50

1. Minimum Circuit Ampacity.
2. Dual Element, Time Delay Type.
3. HACR type per NEC.

**JA6ZF With Powered Convenience Outlet (Belt Drive High Static) Cooling With/Without Electric Heat**

Size (Tons)	Volt	Compressors (each)			OD Fan Motors (each)	Supply Blower Motor	Pwr Conv Outlet	Electric Heat Option				MCA <sup>1</sup> (Amps)	Max Fuse <sup>2</sup> / Breaker <sup>3</sup> Size (Amps)
		RLA	LRA	MCC	FLA	FLA	FLA	Model	kW	Stages	Amps		
JA6 (6.0)	208-3-60	19.0	123.0	29.7	5.3	10.9	10.0	None	-	-	-	50.0	60
								E05	4.0	1	11.1	50.0	60
								E07	5.6	1	15.5	50.0	60
								E10	8.0	1	22.2	53.9	60
								E15	11.9	2	33.0	67.4	70
								E20	15.9	2	44.1	81.3	90
	230-3-60	19.0	123.0	29.7	5.3	10.9	10.0	None	-	-	-	50.0	60
								E05	5.3	1	12.7	50.0	60
								E07	7.5	1	18.0	50.0	60
								E10	10.6	1	25.5	58.0	60
								E15	15.9	2	38.2	73.9	80
								E20	21.2	2	51.0	89.9	90
	460-3-60	9.7	62.0	15.2	5.3	5.3	5.0	None	-	-	-	25.1	30
								E07	6.8	1	8.2	25.1	30
								E10	10.1	1	12.1	28.1	30
								E15	13.6	2	16.4	33.3	35
								E20	19.5	2	23.5	42.2	45
								E30	28.8	2	34.6	56.2	60
	575-3-60	7.4	50.0	11.6	5.3	4.1	4.0	None	-	-	-	19.5	25
								E10	10.6	1	10.2	22.9	25
								E15	15.9	1	15.3	29.2	30
								E20	21.2	2	20.4	35.6	40
								E30	30.4	2	29.3	46.7	50

1. Minimum Circuit Ampacity.
2. Dual Element, Time Delay Type.
3. HACR type per NEC.

**JA6ZF With Powered Convenience Outlet (Belt Drive High Static) Cooling With Gas Heat**

Size (Tons)	Volt	Compressors (each)			OD Fan Motors (each)	Supply Blower Motor	Pwr Conv Outlet	MCA <sup>1</sup> (Amps)	Max Fuse <sup>2</sup> / Breaker <sup>3</sup> Size (Amps)
		RLA	LRA	MCC	FLA	FLA	FLA		
JA6 (6.0)	208-3-60	19.0	123.0	29.7	2.3	10.9	10.0	47.0	60.0
	230-3-60								
	460-3-60								
	575-3-60								

1. Minimum Circuit Ampacity.
2. Dual Element, Time Delay Type.
3. HACR type per NEC.

## J03 thru 05ZF With Powered Convenience Outlet (Direct Drive)

Size (Tons)	Volt	Compressors (each)			OD Fan Motors (each)	Supply Blower Motor	Pwr Conv Outlet	Electric Heat Option				MCA <sup>1</sup> (Amps)	Max Fuse <sup>2/</sup> Breaker <sup>3</sup> Size (Amps)
		RLA	LRA	MCC	FLA	FLA	FLA	Model	kW	Stages	Amps		
J03 (3.0)	208-1-60	14.7	74.0	23.0	2.3	6.0	10.0	None	-	-	-	36.7	45
								E05	4.0	1	19.2	44.0	50
								E07	5.6	1	26.9	53.7	60
								E10	8.0	1	38.5	68.1	70
								E15	11.9	2	57.2	91.5	100
								E20	15.9	2	76.4	115.6	125
	230-1-60	14.7	74.0	23.0	2.3	6.0	10.0	None	-	-	-	36.7	45
								E05	5.3	1	22.1	47.6	50
								E07	7.5	1	31.3	59.1	60
								E10	10.6	1	44.2	75.2	80
								E15	15.9	2	66.3	102.8	110
								E20	21.2	2	88.3	130.4	150
	208-3-60	9.1	68.0	14.2	2.3	6.0	10.0	None	-	-	-	29.9	35
								E05	4.0	1	11.1	33.9	35
								E07	5.6	1	15.5	39.4	40
								E10	8.0	1	22.2	47.8	50
								E15	11.9	2	33.0	61.3	70
								E20	15.9	2	44.1	75.2	80
	230-3-60	9.1	68.0	14.2	2.3	6.0	10.0	None	-	-	-	29.9	35
								E05	5.3	1	12.7	35.9	40
E07								7.5	1	18.0	42.6	45	
E10								10.6	1	25.5	51.9	60	
E15								15.9	2	38.2	67.8	70	
E20								21.2	2	51.0	83.7	90	
J04 (4.0)	208-1-60	15.7	84.0	24.5	2.3	7.6	10.0	None	-	-	-	39.5	50
								E05	4.0	1	19.2	46.0	50
								E07	5.6	1	26.9	55.7	60
								E10	8.0	1	38.5	70.1	80
								E15	11.9	2	57.2	93.5	100
								E20	15.9	2	76.4	117.6	125
	230-1-60	15.7	84.0	24.5	2.3	7.6	10.0	None	-	-	-	39.5	50
								E05	5.3	1	22.1	49.6	50
								E07	7.5	1	31.3	61.1	70
								E10	10.6	1	44.2	77.2	80
								E15	15.9	2	66.3	104.8	110
								E20	21.2	2	88.3	132.4	150
	208-3-60	11.2	88.0	17.5	2.3	7.6	10.0	None	-	-	-	33.9	45
								E05	4.0	1	11.1	35.9	45
								E07	5.6	1	15.5	41.4	45
								E10	8.0	1	22.2	49.8	50
								E15	11.9	2	33.0	63.3	70
								E20	15.9	2	44.1	77.2	80
	230-3-60	11.2	88.0	17.5	2.3	7.6	10.0	None	-	-	-	33.9	45
								E05	5.3	1	12.7	37.9	45
E07								7.5	1	18.0	44.6	45	
E10								10.6	1	25.5	53.9	60	
E15								15.9	2	38.2	69.8	70	
E20								21.2	2	51.0	85.7	90	

**J03 thru 05ZF With Powered Convenience Outlet (Direct Drive) (Continued)**

Size (Tons)	Volt	Compressors (each)			OD Fan Motors (each)	Supply Blower Motor	Pwr Conv Outlet	Electric Heat Option				MCA <sup>1</sup> (Amps)	Max Fuse <sup>2/</sup> Breaker <sup>3</sup> Size (Amps)
		RLA	LRA	MCC	FLA	FLA	FLA	Model	kW	Stages	Amps		
J05 (5.0)	208-1-60	21.1	105.0	33.0	2.3	7.6	10.0	None	-	-	-	46.3	60
								E05	4.0	1	19.2	46.3	60
								E07	5.6	1	26.9	55.7	60
								E10	8.0	1	38.5	70.1	80
								E15	11.9	2	57.2	93.5	100
								E20	15.9	2	76.4	117.6	125
	230-1-60	21.1	105.0	33.0	2.3	7.6	10.0	None	-	-	-	46.3	60
								E05	5.3	1	22.1	49.6	60
								E07	7.5	1	31.3	61.1	70
								E10	10.6	1	44.2	77.2	80
								E15	15.9	2	66.3	104.8	110
								E20	21.2	2	88.3	132.4	150
	208-3-60	14.1	88.0	22.0	2.3	7.6	10.0	None	-	-	-	37.5	50
								E05	4.0	1	11.1	37.5	50
								E07	5.6	1	15.5	41.4	50
								E10	8.0	1	22.2	49.8	50
								E15	11.9	2	33.0	63.3	70
								E20	15.9	2	44.1	77.2	80
	230-3-60	14.1	88.0	22.0	2.3	7.6	10.0	None	-	-	-	37.5	50
								E05	5.3	1	12.7	37.9	50
								E07	7.5	1	18.0	44.6	50
								E10	10.6	1	25.5	53.9	60
								E15	15.9	2	38.2	69.8	70
								E20	21.2	2	51.0	85.7	90
							E30	29.6	2	71.2	111.0	125	

1. Minimum Circuit Ampacity.
2. Dual Element, Time Delay Type.
3. HACR type per NEC.



**JA6ZF With Powered Convenience Outlet (Direct Drive) Cooling With/Without Electric Heat**

Size (Tons)	Volt	Compressors (each)			OD Fan Motors (each)	Supply Blower Motor	Pwr Conv Outlet	Electric Heat Option				MCA <sup>1</sup> (Amps)	Max Fuse <sup>2</sup> / Breaker <sup>3</sup> Size (Amps)
		RLA	LRA	MCC	FLA	FLA	FLA	Model	kW	Stages	Amps		
JA6 (6.0)	208-3-60	19.0	123.0	29.7	5.3	7.6	10.0	None	-	-	-	46.7	60
								E05	4.0	1	11.1	46.7	60
								E07	5.6	1	15.5	46.7	60
								E10	8.0	1	22.2	49.8	60
								E15	11.9	2	33.0	63.3	70
								E20	15.9	2	44.1	77.2	80
								E30	22.2	2	61.6	99.0	100
	230-3-60	19.0	123.0	29.7	5.3	7.6	10.0	None	-	-	-	46.7	60
								E05	5.3	1	12.7	46.7	60
								E07	7.5	1	18.0	46.7	60
								E10	10.6	1	25.5	53.9	60
								E15	15.9	2	38.2	69.8	70
								E20	21.2	2	51.0	85.7	90
								E30	29.6	2	71.2	111.0	125

1. Minimum Circuit Ampacity.
2. Dual Element, Time Delay Type.
3. HACR type per NEC.

**JA6ZF With Powered Convenience Outlet (Direct Drive) Cooling With Gas Heat**

Size (Tons)	Volt	Compressors (each)			OD Fan Motors (each)	Supply Blower Motor	Pwr Conv Outlet	MCA <sup>1</sup> (Amps)	Max Fuse <sup>2</sup> / Breaker <sup>3</sup> Size (Amps)
		RLA	LRA	MCC	FLA	FLA	FLA		
JA6 (6.0)	208-3-60 230-3-60	19.0	123.0	29.7	2.3	7.6	10.0	43.7	60.0

1. Minimum Circuit Ampacity.
2. Dual Element, Time Delay Type.
3. HACR type per NEC.

**Table 8: Physical Data**  
**J03 thru 05ZF Physical Data**

Component	Models											
	J03ZF				J04ZF				J05ZF			
Nominal Tonnage	3.0				4.0				5.0			
<b>AHRI COOLING PERFORMANCE</b>												
Gross Capacity @ AHRI A point (Btu)	37000				49300				59000			
AHRI net capacity (Btu)	35500				47500				56500			
EER	11.0				11.0				10.8			
SEER	13.0				13.0				13.0			
IPLV	-				-				-			
Nominal CFM	1200				1500				1750			
System power (KW)	3.23				4.32				5.23			
Refrigerant type	R-410A				R-410A				R-410A			
Refrigerant charge (lb-oz)												
System 1	4-4				5-8				5-8			
<b>AHRI HEATING PERFORMANCE</b>												
Heating model	N04	N08	D06	D10	N06	N10	D06	D10	N08	N10	D06	D10
Heat input (K Btu)	50	100	75	115	75	125	75	125	100	125	75	125
Heat output (K Btu)	40	80	60.8	92	60	100	60.8	100.6	80	100	60.8	100.6
AFUE %	80.9	80.5	-	-	80.9	80.3	-	-	80.5	80.3	-	-
Steady state efficiency (%)	-	-	81.1	80.2	-	-	81.1	80.5	-	-	81.1	80.5
No. burners	2	4	3	5	3	5	3	5	4	5	3	5
No. stages	1	1	2	2	1	1	2	2	1	1	2	2
Temperature Rise Range (°F)	15-45	45-75	35-70	55-90	25-70	45-75	25-70	45-75	25-55	35-75	20-55	35-75
Gas Limit Setting (°F) - Direct Drive	240	170	210	200	210	165	210	165	170	165	210	165
Gas Limit Setting (°F) - Belt Drive	240	210	240	200	240	210	240	210	210	210	210	210
Gas piping connecting (in.)	1/2	1/2	1/2	1/2	1/2	1/2	1/2	1/2	1/2	1/2	1/2	1/2
<b>DIMENSIONS (inches)</b>												
Length	82 1/4				82 1/4				82 1/4			
Width	44 7/8				44 7/8				44 7/8			
Height	32 5/8				32 5/8				32 5/8			
<b>OPERATING WT. (lbs.)</b>	468				541				569			
<b>COMPRESSORS</b>												
Type	Recip				Recip				Recip			
Quantity	1				1				1			
Unit Capacity Steps (%)	100				100				100			
<b>CONDENSER COIL DATA</b>												
Face area (Sq. Ft.)	16.3				16.3				16.3			
Rows	1				1				1			
Fins per inch	23				23				23			
Tube diameter (in.)	0.71 / 18				0.71 / 18				0.71 / 18			
Circuitry Type	2-pass Microchannel				2-pass Microchannel				2-pass Microchannel			
<b>EVAPORATOR COIL DATA</b>												
Face area (Sq. Ft.)	5.06				5.06				5.06			
Rows	3				4				4			
Fins per inch	13				13				13			
Tube diameter	0.375				0.375				0.375			
Circuitry Type	Intertwined				Intertwined				Intertwined			
Refrigerant control	Orifice				Orifice				Orifice			

**J03 thru 05ZF Physical Data (Continued)**

Component	Models					
	J03ZF		J04ZF		J05ZF	
Nominal Tonnage	3.0		4.0		5.0	
<b>CONDENSER FAN DATA</b>						
Quantity	1		1		1	
Fan diameter (Inch)	24		24		24	
Type	Prop		Prop		Prop	
Drive type	Direct Drive		Direct Drive		Direct Drive	
Quantity of motors	1		1		1	
Motor HP each	1/2		1/2		1/2	
No. speeds	1		1		1	
RPM	1090		1090		1090	
Nominal total CFM	3800		4200		4200	
<b>BELT DRIVE EVAP FAN DATA</b>						
Quantity	1		1		1	
Fan Size (Inch)	12 x 10		12 x 10		12 x 10	
Type	Centrifugal		Centrifugal		Centrifugal	
Motor Sheave	1VL44	1VP56	1VL44	1VP56	1VL44	1VP56
Blower Sheave	AK64	AK66	AK56	AK61	AK56	AK56
Belt	A37	A39	A36	A38	A36	A38
Motor HP each	1-1/2	1-1/2	1-1/2	1-1/2	1-1/2	2
RPM	1725		1725		1725	
Frame size	56		56		56	
<b>DIRECT DRIVE EVAP FAN DATA</b>						
Quantity	1		1		1	
Fan Size (Inch)	12 x 10		12 x 10		12 x 10	
Type	Centrifugal		Centrifugal		Centrifugal	
Motor HP each	1/2		1		1	
RPM	1050		1050		1050	
<b>FILTERS</b>						
15" x 20" x 1" or 2"	2		2		2	
14" x 25" x 1" or 2"	1		1		1	

**NOTE:** All 2 Stage Gas Heat, 60% Capacity 1<sup>st</sup> Stage, 40% Capacity 2<sup>nd</sup> Stage.

**JA6ZF Physical Data**

Component	Models			
	JA6ZF			
Nominal Tonnage	6.0			
<b>AHRI COOLING PERFORMANCE</b>				
Gross Capacity @ AHRI A point (Btu)	70360			
AHRI net capacity (Btu)	68000			
EER	11.2 <sup>1</sup> / 11.0 <sup>2</sup>			
IEER	11.3			
Nominal CFM	2000			
System power (KW)	6.07			
Refrigerant type	R-410A			
Refrigerant charge (lb-oz)				
System 1	6-4			
<b>AHRI HEATING PERFORMANCE</b>				
Heating model	N08	N10	D06	D10
Heat input (K Btu)	100	125	75	125
Heat output (K Btu)	80	100	60.8	100.6
AFUE %	80.5	80.3	-	-
Steady state efficiency (%)	-	-	81.1	80.5
No. burners	4	5	3	5
No. stages	1	1	2	2
Temperature Rise Range (°F)	25-55	30-75	15-45	30-75
Gas Limit Setting (°F) - Direct Drive	170	165	210	165
Gas Limit Setting (°F) - Belt Drive	210	210	210	210
Gas piping connecting (in.)	1/2	1/2	1/2	1/2
<b>DIMENSIONS (inches)</b>				
Length	82 1/4			
Width	44 7/8			
Height	32 5/8			
<b>OPERATING WT. (lbs.)</b>	640			
<b>COMPRESSORS</b>				
Type	Scroll			
Quantity	1			
Unit Capacity Steps (%)	100			
<b>CONDENSER COIL DATA</b>				
Face area (Sq. Ft.)	16.3			
Rows	1			
Fins per inch	23			
Tube diameter (in.)	1.0 / 25.4			
Circuitry Type	2-pass Microchannel			
<b>EVAPORATOR COIL DATA</b>				
Face area (Sq. Ft.)	5.06			
Rows	4			
Fins per inch	13			
Tube diameter	0.375			
Circuitry Type	Intertwined			
Refrigerant control	Fixed Orifice			

**JA6ZF Physical Data (Continued)**

Component	Models	
	JA6ZF	
Nominal Tonnage	6.0	
<b>CONDENSER FAN DATA</b>		
Quantity	1	
Fan diameter (Inch)	24	
Type	Prop	
Drive type	Direct Drive	
No. speeds	1	
Number of motors	1	
Motor HP each	1/2 <sup>3</sup>	1/2 <sup>4</sup>
RPM	1100	1090
Nominal total CFM	4200	4200
<b>BELT DRIVE EVAP FAN DATA</b>		
Quantity	1	
Fan Size (Inch)	12 x 10	
Type	Centrifugal	
Motor Sheave	1VL44	1VP56
Blower Sheave	AK56	AK56
Belt	A36	A38
Motor HP each	1-1/2	3
RPM	1725	
Frame size	56	
<b>DIRECT DRIVE EVAP FAN DATA</b>		
Quantity	1	
Fan Size (Inch)	12 x 10	
Type	Centrifugal	
Motor HP each	1	
RPM	1050	
<b>FILTERS</b>		
15" x 20" x 1" or 2"	2	
14" x 25" x 1" or 2"	1	

1. Cooling Only or Cooling with Electric Heat Unit
2. Cooling with Gas Heat Unit
3. Cooling Only or Cooling with Electric Heat Unit (ECM O.D. Fan Motor)
4. Cooling with Gas Heat Unit (PSC O.D. Fan Motor)

### Optional Electric Heat

The factory or field installed heaters are wired for single point power supply. Power supply need only be brought into the single point terminal block, and thermostat wiring to the low voltage terminal strip located in the upper portion of the unit control box.

These CSA approved heaters are located within the central compartment of the unit with the heater elements extending in to the supply air chamber.

Fuses are supplied, where required, by the factory. Some kW sizes require fuses and others do not. Refer to Table 9 for minimum CFM limitations and to Table 7 for electrical data.

**Table 9: Electric Heat Minimum Supply Air**

Size (Tons)	Voltage	Minimum Supply Air (CFM)					
		Heater kW					
		5	7	10	15	20	30
J03 (3.0)	208/230-1-60	900	900	900	900	900	-
	208/230-3-60	900	900	900	900	900	-
	460-3-60	-	900	900	900	900	-
	600-3-60	-	-	900	900	900	-
J04 (4.0)	208/230-1-60	1200	1200	1200	1200	1200	-
	208/230-3-60	1200	1200	1200	1200	1200	-
	460-3-60	-	1200	1200	1200	1200	-
	600-3-60	-	-	1200	1200	1200	-
J05 (5.0)	208/230-1-60	1500	1500	1500	1500	1500	1500
	208/230-3-60	1500	1500	1500	1500	1500	1500
	460-3-60	-	1500	1500	1500	1500	1500
	600-3-60	-	-	1500	1500	1500	1500
JA6 (6.0)	208/230-3-60	1500	1500	1500	1500	1500	1500
	460-3-60	-	1500	1500	1500	1500	1500
	600-3-60	-	-	1500	1500	1500	1500

### Optional Gas Heat

These gas-fired heaters have aluminized-steel or optional stainless steel, tubular heat exchangers with spark ignition with proven pilot.

All gas heaters are shipped from the factory equipped for natural gas use. See Gas Heat Application Data Table.

For natural gas heating installations in locations requiring low Nox emissions, Accessory model 1LN0406 must be used.

**Table 10: Gas Heat Application Data**

Gas Heat Option	Input Capacity (MBH)	Output Capacity (MBH)	Available On Models	Gas Rate <sup>1</sup> (Ft <sup>3</sup> /hr)	Temperature Rise °F At Full Input <sup>2</sup>	
					Min.	Max.
N04	50	40	3 TON	47	15	45
N06	75	60	4 TON	70	25	70
N08	100	80	3/5/6 TON	93	45/25/25	75/55/55
N10	125	100	4/5/6 TON	116	45/35/30	75/75/75
D06	75	61	3/4/5/6 TON	70	35/25/20/15	70/70/55/45
D10	115	92	3 TON	107	55	90
D10	125	101	4/5/6 TON	116	45/35/30	75/75/75

NOTE: Gas Heaters are shipped available for natural gas, but can be converted to L.P. with Kit Model No. 1NP0440 or 1NP0485 (2 Stage). All furnaces meet the latest California seasonal efficiency requirements.

1. Based on 1075 Btu/Ft.<sup>3</sup>.
2. The air flow must be adjusted to obtain a temperature rise within the range shown.

## Gas Piping

Proper sizing of gas piping depends on the cubic feet per hour of gas flow required, specific gravity of the gas and the length of run. "National Fuel Gas Code" Z223.1 (in U.S.A.) or the current Gas Installation Codes CSA-B149.1 (in Canada) should be followed in all cases unless superseded by local codes or gas utility requirements. Refer to the Pipe Sizing Table 11. The heating value of the gas may differ with locality. The value should be checked with the local gas utility.

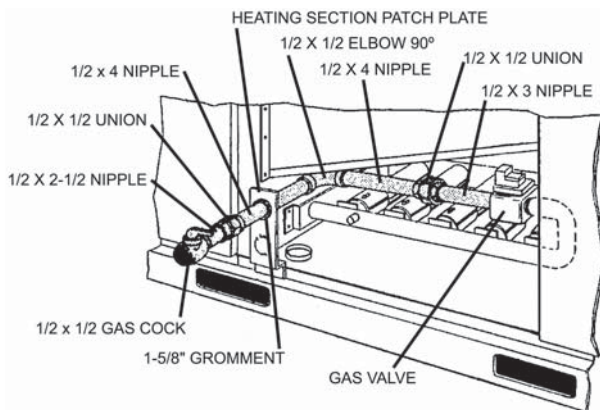

Figure 14: Side Entry Gas Piping

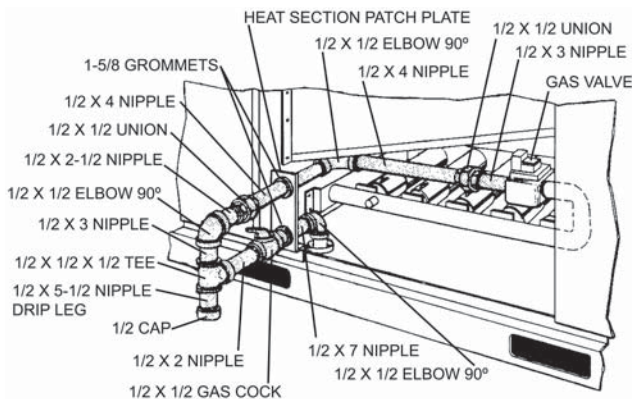

Figure 15: Bottom Entry Gas Piping

Table 11: Gas Pipe Sizing - Capacity of Pipe

Length of Pipe (ft.)	Nominal Iron Pipe Size		
	3/4 in.	1 in.	1-1/4 in.
10	278	520	1050
20	190	350	730
30	152	285	590
40	130	245	500
50	115	215	440
60	105	195	400
70	96	180	370
80	90	170	350
90	84	160	320
100	79	150	305

**NOTE:** Maximum capacity of pipe in cubic feet of gas per hour based upon a pressure drop of 0.3 inch W.C. and 0.6 specific gravity gas.

**NOTE:** There may be a local gas utility requirement specifying a minimum diameter for gas piping. All units require a 1/2 inch pipe connection at the entrance fitting. Line should not be sized smaller than the entrance fitting size.

## Gas Connection

The gas supply line can be routed within the space and roof curb, exiting through the unit's basepan. Refer to Figure 6 for the gas piping inlet locations. Typical supply piping arrangements are shown in Figures 14 and 15. All pipe nipples, fittings, and the gas cock are field supplied or may be purchased in UP accessory kit #1GP0401.

### Gas piping recommendations:

1. A drip leg and a ground joint union must be installed in the gas piping.
2. Where required by local codes, a manual shut-off valve must be installed outside of the unit.
3. Use wrought iron or steel pipe for all gas lines. Pipe dope should be applied sparingly to male threads only.

## WARNING

Natural gas may contain some propane. Propane is an excellent solvent and will quickly dissolve white lead and most standard commercial compounds. A special pipe dope must be used when assembling wrought iron or steel pipe. Shellac based compounds such as Gaskolac or Stalastic, and compounds such as Rectorseal #5, Clydes's or John Crane may be used.

4. All piping should be cleaned of dirt and scale by hammering on the outside of the pipe and blowing out loose particles. Before initial start-up, be sure that all gas lines external to the unit have been purged of air.
5. The gas supply should be a separate line and installed in accordance with all safety codes as prescribed under "Limitations".
6. A 1/8-inch NPT plugged tapping, accessible for test gage connection, must be installed immediately upstream of the gas supply connection to the unit.
7. After the gas connections have been completed, open the main shut-off valve admitting *normal gas pressure* to the mains. *Check all joints for leaks with soap solution or other material suitable for the purpose. NEVER USE A FLAME.*

**▲ WARNING****FIRE OR EXPLOSION HAZARD**

Failure to follow the safety warning exactly could result in serious injury, death or property damage.

Never test for gas leaks with an open flame. Use a commercially available soap solution made specifically for the detection of leaks to check all connections. A fire or explosion may result causing property damage, personal injury or loss of life.

**▲ CAUTION**

The furnace and its individual shut-off valve must be disconnected from the gas supply piping system during any pressure testing at pressures in excess of 1/2 PSIG.

Pressures greater than 1/2 PSIG will cause gas valve damage resulting in a hazardous condition. If it is subjected to a pressure greater than 1/2 PSIG, the gas valve must be replaced.

The furnace must be isolated from the gas supply piping system by closing its individual manual shut-off valve during any pressure testing of the gas supply piping system at test pressures equal to or less than 1/2 PSIG.

**▲ WARNING**

Threaded joints should be coated with a sealing compound that is resistant to the action of liquefied petroleum gases. **Do not use Teflon tape.**

**Lp Units, Tanks And Piping**

All gas heat units are shipped from the factory equipped for natural gas use only. The unit may be converted in the field for use with LP gas with accessory kit model number 1NP0440 or 1NP0485 (2 Stage).

All LP gas equipment must conform to the safety standards of the National Fire Protection Association.

For satisfactory operation, adequate LP gas pressure must be provided at the unit manifold under full load. Maintaining proper gas pressure depends on three main factors:

1. The vaporization rate which depends on the temperature of the liquid and the "wetted surface" area of the container(s).
2. The proper pressure regulation. (Two-stage regulation is recommended).

3. The pressure drop in the lines between regulators and between the second stage regulator and the appliance. Pipe size required will depend on the length of the pipe run and the total load of all appliances.

Complete information regarding tank sizing for vaporization, recommended regulator settings, and pipe sizing is available from most regulator manufacturers and LP gas suppliers.

**▲ WARNING**

LP gas is an excellent solvent and will quickly dissolve white lead and most standard commercial compounds. A special pipe dope must be used when assembling wrought iron or steel pipe for LP. Shellac base compounds such as Gaskolac or Stalastic, and compounds such as Rectorseal #5, Clyde's, or John Crane may be used.

Check all connections for leaks when piping is completed using a soap solution. **NEVER USE A FLAME.**

**▲ WARNING****FIRE OR EXPLOSION HAZARD**

Failure to follow the safety warning exactly could result in serious injury, death or property damage.

Never test for gas leaks with an open flame. Use a commercially available soap solution made specifically for the detection of leaks to check all connections. A fire or explosion may result causing property damage, personal injury or loss of life.

**Vent And Combustion Air Hoods**

The vent hood and combustion air hood (with screens) are shipped attached to the blower housing in the blower compartment. These hoods must be installed to assure proper unit function. All hoods must be fastened to the outside of the gas heat access panel with the screws provided in the bag also attached to the blower housing.

The screen for the combustion air intake hood is secured to the inside of the access panel opening with three fasteners and the screws used for mounting the hood to the panel. The top flange of this hood slips in under the top of the access panel opening when installing. Refer to Vent and Combustion Air Hood Figure 16.

The vent hood is installed by inserting the top flange of the hood into the slotted opening in the access panel and securing in place.

The products of combustion are discharged horizontally through this screened, hooded vent opening on the gas heat access panel.



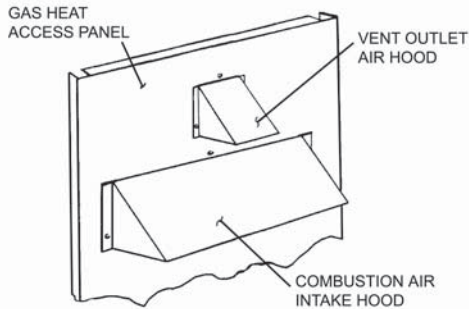

Figure 16: Vent And Combustion Air Hood

## CAUTION

An adhesive backed label is provided over the outside of the combustion air inlet opening to prevent moisture from entering the unit, which could cause damage to electrical components. Allow this closure label to remain in place until the combustion air hood is to be installed.

## Options/Accessories

### Electric Heat

Electric heaters are available as factory-installed options or field-installed accessories. Refer to electric heat instructions for installation. These heaters mount in the heat compartment with the heating elements extending into the supply air chamber. All electric heaters are fused and intended for use with single point power supply.

### Economizer/Motorized Damper and Rain Hood

The instruction for the optional economizer/motorized damper and rain hood can be found in form 035-07364-000. Use these instructions when field assembling an economizer rain hood onto a unit. The outdoor and return air dampers, the damper actuator, the damper linkage, the outdoor and return air divider baffles, and all the control sensors are factory mounted as part of the "Factory installed" economizer/motorized damper options.

### Power Exhaust/barometric Relief Damper and Rain Hood

The instructions for the power exhaust/barometric relief damper and rain hood can be found in form 530.18-N1.10V.

All of the components, including the dampers, hardware, and mounting instructions are shipped in a single package external from the unit and must be field assembled and installed.

Power exhaust is only available as a field installed accessory.

### Economizer And Power Exhaust Set Point Adjustments

Remove the top rear access panel from the unit. Locate the economizer control module, where the following adjustments will be made.

## CAUTION

Extreme care must be exercised in turning all set point, maximum and minimum damper positioning adjustment screws to prevent twisting them off.

### Minimum Position Adjustment

- Check that the damper blades move smoothly without binding; carefully turn the Minimum Position Adjust screw (found on the damper control module) fully clockwise and then set the thermostat indoor fan switch to the ON position and then OFF or energize and de-energize terminals "R" to "G".
- With the thermostat set to the indoor fan ON position or terminals "R" to "G" energized, turn the Minimum Position Adjusting screw (located on the damper control module) counterclockwise until the desired minimum damper position has been attained.

### Enthalpy Set Point Adjustment

- The enthalpy set point may now be set by selecting the desired set point shown in the Enthalpy Set Point Adjustment Figure 17. Adjust as follows:
- For a single enthalpy operation carefully turn the set point adjusting screw (found on the damper control module) to the "A", "B", "C" or "D" setting corresponding to the lettered curve of the Enthalpy Set Point Adjustment Figure 18.
- For a dual enthalpy operation, carefully turn the set point adjusting screw fully clockwise past the "D" setting.

### Power Exhaust Damper Set Point (With Or Without Power Exhaust)

- With no power exhaust option, adjust the Exhaust Air Adjustment Screw fully clockwise.
- With power exhaust option, each building pressurization requirement will be different. The point at which the power exhaust comes on is determined by the economizer damper position (Percent Open). The Exhaust Air Adjustment Screw should be set at the Percent Open of the economizer damper at which the power exhaust is needed. It can be set from 0 to 100% damper open.

### Indoor Air Quality AQ

Indoor Air Quality (indoor sensor input): Terminal AQ accepts a +2 to +10 Vdc signal with respect to the (AQ1) terminal. When the signal is below it's set point, the actuator is allowed to modulate normally in accordance with the enthalpy and mixed air sensor inputs. When the AQ signal exceeds it's set point setting and there is no call for free cooling, the actuator is proportionately modulated from the 2 to 10 Vdc signal, with 2 Vdc corresponding to full closed and 10 Vdc corresponding to full open. When there is no call for free cooling, the damper position is limited by the IAQ Max damper position setting. When the signal exceeds it's set point (Demand Control Ventilation Set Point) setting and there is a call for free cooling,

the actuator modulates from the minimum position to the full open position based on the highest call from either the mixed air sensor input or the AQ voltage input.

- Optional CO<sub>2</sub> Space Sensor Kit Part # 2AQ04700324
- Optional CO<sub>2</sub> Sensor Kit Part # 2AQ04700424

Replace the economizer access panel.

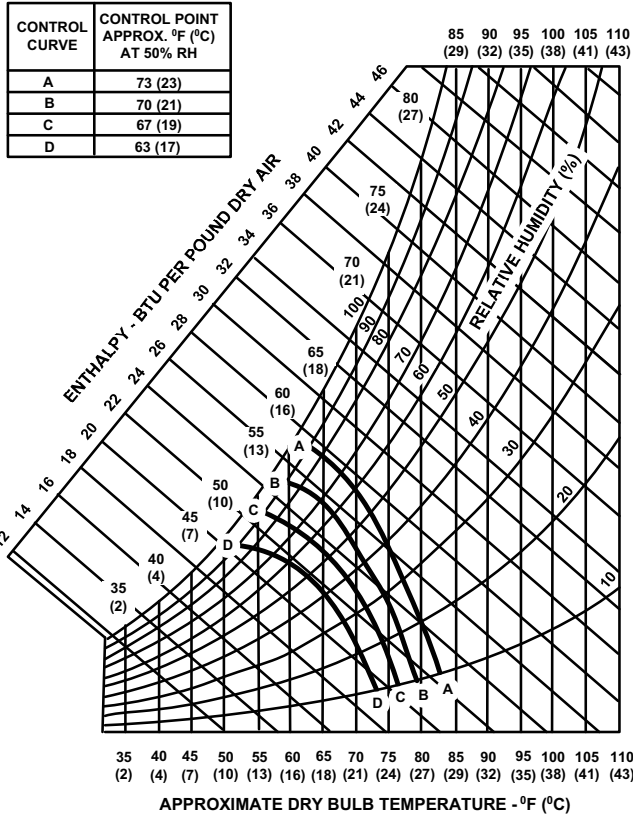

Figure 17: Enthalpy Set Point Chart

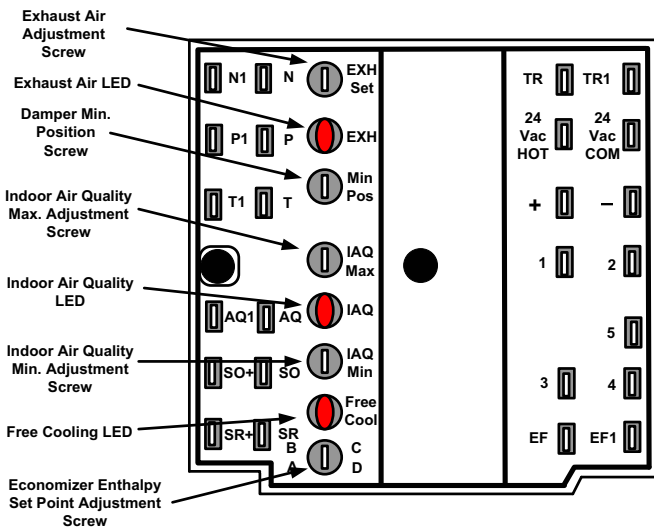

Figure 18: Honeywell Economizer Control W7212

**Phasing**

J\*\*ZF units are properly phased at the factory. Check for proper compressor rotation. If the blower or compressors rotate in the wrong direction at start-up, the electrical connection to the unit is misphased. Change the phasing of the **Field Line Connection at the factory or field supplied disconnect** to obtain proper rotation. (Scroll compressors operate in only one direction. If the scroll is drawing low amperage, has similar suction and discharge pressures, or producing a high noise level, the scroll is misphased.)

⚠ CAUTION

Scroll compressors require proper rotation to operate correctly. Units are properly phased at the factory. Do not change the internal wiring to make the blower condenser fans, or compressor rotate correctly.

**Blower Rotation**

Check for proper supply air blower rotation. If the blower is rotating backwards, the line voltage at the unit point of power connection is misphased (See 'PHASING').

**Belt Tension**

The tension on the belt should be adjusted as shown in Figure 19.

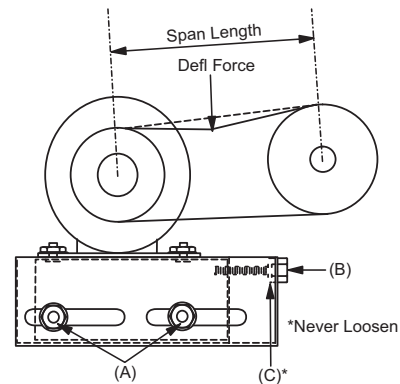

Figure 19: Belt Adjustment

**CAUTION**

Procedure for adjusting belt tension:

1. Loosen six nuts (top and bottom) A.
2. Adjust by turning (B).
3. Never loosen nuts (C).
4. Use belt tension checker to apply a perpendicular force to one belt at the midpoint of the span as shown. Deflection distance of 4mm (5/32") is obtained.

To determine the deflection distance from normal position, use a straight edge from sheave to sheave as reference line. The recommended deflection force is as follows:

Tension new belts at the max. deflection force recommended for the belt section. Check the belt tension at least two times during the first 24 hours of operation. Any retensioning should fall between the min. and max. deflection force values.

5. After adjusting retighten nuts (A).

**CFM Static Pressure and Power-Altitude and Temperature Corrections**

The information below should be used to assist in application of product when being applied at altitudes at or exceeding 1000 feet above sea level.

The air flow rates listed in the standard blower performance tables are based on standard air at sea level. As the altitude or temperature increases, the density of air decreases. In order to use the indoor blower tables for high altitude applications, certain corrections are necessary.

A centrifugal fan is a "constant volume" device. This means that, if the rpm remains constant, the CFM delivered is the same regardless of the density of the air. However, since the air at high altitude is less dense, less static pressure will be generated and less power will be required than a similar application at sea level. Air density correction factors are shown in Table 12 and Figure 20.

**Table 12: Altitude/Temperature Correction Factors**

Air Temp.	Altitude (Ft.)										
	0	1000	2000	3000	4000	5000	6000	7000	8000	9000	10000
40	1.060	1.022	0.986	0.950	0.916	0.882	0.849	0.818	0.788	0.758	0.729
50	1.039	1.002	0.966	0.931	0.898	0.864	0.832	0.802	0.772	0.743	0.715
60	1.019	0.982	0.948	0.913	0.880	0.848	0.816	0.787	0.757	0.729	0.701
70	1.000	0.964	0.930	0.896	0.864	0.832	0.801	0.772	0.743	0.715	0.688
80	0.982	0.947	0.913	0.880	0.848	0.817	0.787	0.758	0.730	0.702	0.676
90	0.964	0.929	0.897	0.864	0.833	0.802	0.772	0.744	0.716	0.689	0.663
100	0.946	0.912	0.880	0.848	0.817	0.787	0.758	0.730	0.703	0.676	0.651

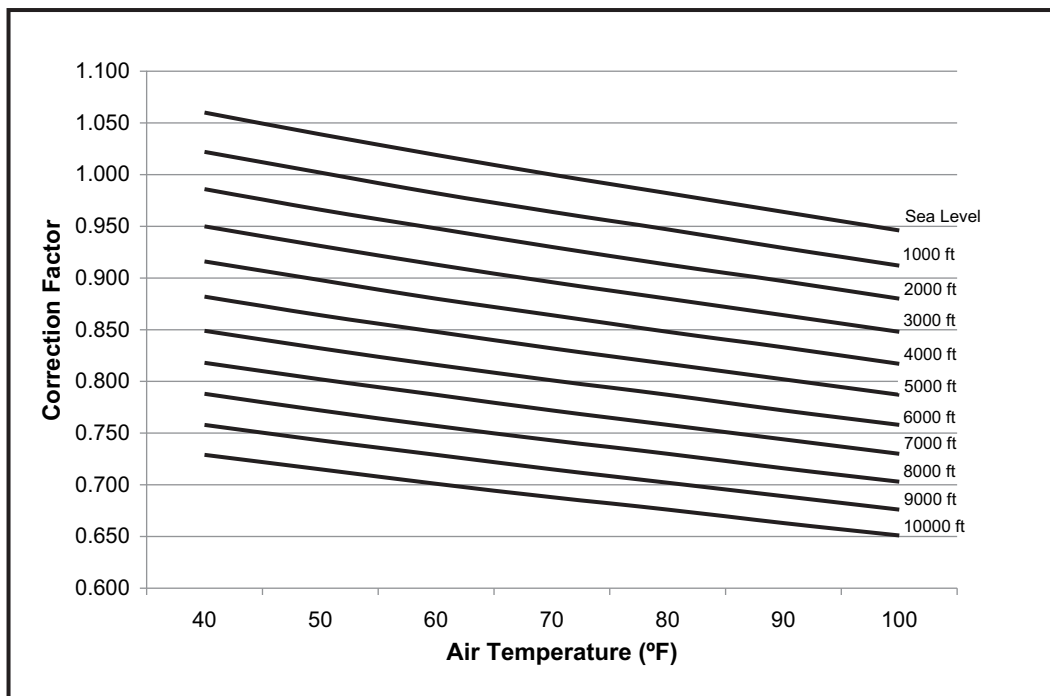

**Figure 20: Altitude/Temperature Correction Factors**

The examples below will assist in determining the airflow performance of the product at altitude.

**Example 1:** What are the corrected CFM, static pressure, and BHP at an elevation of 5,000 ft. if the blower performance data is 1,400 CFM, 0.6 IWC and 0.67 BHP?

**Solution:** At an elevation of 5,000 ft. the indoor blower will still deliver 1,400 CFM if the rpm is unchanged. However, Table 13 must be used to determine the static pressure and BHP. Since no temperature data is given, we will assume an air temperature of 70°F. Table 12 shows the correction factor to be 0.832.

$$\text{Corrected static pressure} = 0.6 \times 0.832 = 0.499 \text{ IWC}$$

$$\text{Corrected BHP} = 0.67 \times 0.832 = 0.56$$

**Example 2:** A system, located at 5,000 feet of elevation, is to deliver 1,400 CFM at a static pressure of 1.5". Use the unit

blower tables to select the blower speed and the BHP requirement.

**Solution:** As in the example above, no temperature information is given so 70°F is assumed.

The 1.5" static pressure given is at an elevation of 5,000 ft. The first step is to convert this static pressure to equivalent sea level conditions.

$$\text{Sea level static pressure} = 1.5 / .832 = 1.802 \text{"} "$$

Enter the blower table at 1,400 sCFM and static pressure of 1.802". The rpm listed will be the same rpm needed at 5,000 ft.

Suppose that the corresponding BHP listed in the table is 0.7. This value must be corrected for elevation.

$$\text{BHP at 5,000 ft.} = 0.7 \times .832 = 0.58$$

**Drive Selection**

1. Determine side or bottom supply air duct application.
2. Determine desired airflow.
3. Calculate or measure the amount of external static pressure.
4. Using the operating point determined from steps 1, 2 & 3, locate this point on the appropriate supply air blower performance table. (Linear interpolation may be necessary.)
5. Noting the RPM and BHP from step 4, locate the appropriate motor and/or drive on the RPM selection table.
6. Review the BHP compared to the motor options available. Select the appropriate motor and/or drive.
7. Review the RPM range for the motor options available. Select the appropriate drive if multiple drives are available for the chosen motor.
8. Determine turns open to obtain the desired operation point.

**Example**

1. 2200 CFM
2. 1.6 iwg
3. Using the supply air blower performance table below, the following data point was located: 1478 RPM & 1.82 BHP.
4. Using the RPM selection table below, Size X and Model Y is found.
5. 1.82 BHP exceeds the maximum continuous BHP rating of the 1.5 HP motor. The 2 HP motor is required.
6. 1478 RPM is within the range of the 2 HP drive.
7. Using the 2 HP motor and drive, 2.5 turns open will achieve 1478 RPM.

**Example Supply Air Blower Performance**

Air Flow (CFM)	Available External Static Pressure - IWG																			
	0.2		0.4		0.6		0.8		1.0		1.2		1.4		1.6		1.8		2.0	
	RPM	BHP	RPM	BHP	RPM	BHP	RPM	BHP	RPM	BHP	RPM	BHP	RPM	BHP	RPM	BHP	RPM	BHP	RPM	BHP
	Field Supplied Drive		Standard Drive Option						High Static Drive Option											
2000	907	1.00	990	1.07	1070	1.15	1146	1.23	1220	1.31	1291	1.40	1359	1.49	1425	1.58	1488	1.68	1550	1.77
2200	960	1.24	1043	1.31	1123	1.39	1199	1.47	1273	1.55	1344	1.64	1412	1.73	1478	1.82	1541	1.92	1602	2.01
2400	1015	1.51	1099	1.59	1178	1.66	1255	1.74	1329	1.83	1400	1.92	1468	2.01	1534	2.10	1597	2.19	1658	2.29
2600	1074	1.83	1157	1.90	1237	1.98	1314	2.06	1387	2.14	1458	2.23	-	-	-	-	-	-	-	-

**Table X: RPM Selection**

Size (Tons)	Model	HP	Max BHP	Motor Sheave	Blower Sheave	5 Turns Open	4 Turns Open	3 Turns Open	2 Turns Open	1 Turn Open	Fully Closed
X	Y	1.5	1.73	1VL44	AK56	930	995	1060	1130	1195	1260
		2	2.3	1VP56	AK56	1325	1395	1460	1525	1590	1660

**Table 13: J\*\*ZF Blower Performance Side Duct**

**J03ZF (3 Ton Belt Drive) Side Duct**

Air Flow (CFM)	Available External Static Pressure - IWG <sup>1</sup>																			
	0.2		0.4		0.6		0.8		1.0		1.2		1.4		1.6		1.8		2.0	
	RPM	BHP	RPM	BHP	RPM	BHP	RPM	BHP	RPM	BHP	RPM	BHP	RPM	BHP	RPM	BHP	RPM	BHP	RPM	BHP
	Field Supplied Drive				Standard Drive Option						High Static Drive Option									
800	634	0.34	735	0.39	828	0.45	914	0.52	995	0.59	1070	0.67	1140	0.75	1207	0.83	1270	0.92	1332	1.00
1000	659	0.39	760	0.45	853	0.51	939	0.57	1019	0.65	1094	0.72	1165	0.80	1232	0.89	1295	0.97	1356	1.06
1200	685	0.47	786	0.52	879	0.58	965	0.65	1045	0.72	1120	0.80	1191	0.88	1258	0.96	1321	1.05	1382	1.13
1400	716	0.57	816	0.62	909	0.68	995	0.75	1076	0.82	1151	0.90	1221	0.98	1288	1.06	1352	1.15	1413	1.23
1600	752	0.69	852	0.75	945	0.81	1032	0.88	1112	0.95	1187	1.03	1258	1.11	1324	1.19	1388	1.27	1449	1.36
																				FS <sup>4</sup>

1. Blower performance includes gas heat exchangers and 1" filters. See STATIC RESISTANCE table for additional applications.
2. See RPM SELECTION table to determine desired motor sheave setting and to determine the maximum continuous BHP.
3. kW = BHP x 0.932.
4. Field Supplied Drive.

**J04ZF (4 Ton Belt Drive) Side Duct**

Air Flow (CFM)	Available External Static Pressure - IWG <sup>1</sup>																			
	0.2		0.4		0.6		0.8		1.0		1.2		1.4		1.6		1.8		2.0	
	RPM	BHP	RPM	BHP	RPM	BHP	RPM	BHP	RPM	BHP	RPM	BHP	RPM	BHP	RPM	BHP	RPM	BHP	RPM	BHP
	Field Supplied Drive				Standard Drive Option						High Static Drive Option									
1000	703	0.39	786	0.47	866	0.54	942	0.62	1016	0.71	1087	0.79	1155	0.88	1221	0.98	1284	1.07	1345	1.17
1200	733	0.44	817	0.52	896	0.60	973	0.68	1047	0.76	1118	0.85	1186	0.94	1252	1.03	1315	1.12	1376	1.22
1400	770	0.52	853	0.60	933	0.67	1010	0.76	1083	0.84	1154	0.93	1222	1.02	1288	1.11	1352	1.20	1413	1.30
1600	811	0.64	895	0.71	974	0.79	1051	0.87	1125	0.96	1196	1.04	1264	1.13	1330	1.23	1393	1.32	1454	1.42
1800	857	0.80	940	0.87	1020	0.95	1097	1.03	1171	1.11	1242	1.20	1310	1.29	1375	1.38	1439	1.48	1500	1.58
2000	907	1.00	990	1.07	1070	1.15	1146	1.23	1220	1.31	1291	1.40	1359	1.49	1425	1.58	1488	1.68	1550	1.77
																				FS <sup>4</sup>

1. Blower performance includes gas heat exchangers and 1" filters. See STATIC RESISTANCE table for additional applications.
2. See RPM SELECTION table to determine desired motor sheave setting and to determine the maximum continuous BHP.
3. kW = BHP x 0.932.
4. Field Supplied Drive.

**J05ZF (5 Ton Belt Drive) Side Duct**

Air Flow (CFM)	Available External Static Pressure - IWG <sup>1</sup>																			
	0.2		0.4		0.6		0.8		1.0		1.2		1.4		1.6		1.8		2.0	
	RPM	BHP	RPM	BHP	RPM	BHP	RPM	BHP	RPM	BHP	RPM	BHP	RPM	BHP	RPM	BHP	RPM	BHP	RPM	BHP
	Field Supplied Drive				Standard Drive Option						High Static Drive Option									
1200	733	0.44	817	0.52	896	0.60	973	0.68	1047	0.76	1118	0.85	1186	0.94	1252	1.03	1315	1.12	1376	1.22
1400	770	0.52	853	0.60	933	0.67	1010	0.76	1083	0.84	1154	0.93	1222	1.02	1288	1.11	1352	1.20	1413	1.30
1600	811	0.64	895	0.71	974	0.79	1051	0.87	1125	0.96	1196	1.04	1264	1.13	1330	1.23	1393	1.32	1454	1.42
1800	857	0.80	940	0.87	1020	0.95	1097	1.03	1171	1.11	1242	1.20	1310	1.29	1375	1.38	1439	1.48	1500	1.58
2000	907	1.00	990	1.07	1070	1.15	1146	1.23	1220	1.31	1291	1.40	1359	1.49	1425	1.58	1488	1.68	1550	1.77
2200	960	1.24	1043	1.31	1123	1.39	1199	1.47	1273	1.55	1344	1.64	1412	1.73	1478	1.82	1541	1.92	1602	2.01
2400	1015	1.51	1099	1.59	1178	1.66	1255	1.74	1329	1.83	1400	1.92	1468	2.01	1534	2.10	1597	2.19	1658	2.29
2600	1074	1.83	1157	1.90	1237	1.98	1314	2.06	1387	2.14	1458	2.23	-	-	-	-	-	-	-	-

1. Blower performance includes gas heat exchangers and 1" filters. See STATIC RESISTANCE table for additional applications.
2. See RPM SELECTION table to determine desired motor sheave setting and to determine the maximum continuous BHP.
3. kW = BHP x 0.932.

**JA6ZF (6 Ton Belt Drive) - Side Duct**

Air Flow (CFM)	Available External Static Pressure - IWG <sup>1</sup>																			
	0.2		0.4		0.6		0.8		1.0		1.2		1.4		1.6		1.8		2.0	
	RPM	BHP	RPM	BHP	RPM	BHP	RPM	BHP	RPM	BHP	RPM	BHP	RPM	BHP	RPM	BHP	RPM	BHP	RPM	BHP
	Field Supplied Drive				Standard Drive Option						High Static Drive Option									
1600	811	0.64	895	0.71	974	0.79	1051	0.87	1125	0.96	1196	1.04	1264	1.13	1330	1.23	1393	1.32	1454	1.42
1800	857	0.80	940	0.87	1020	0.95	1097	1.03	1171	1.11	1242	1.20	1310	1.29	1375	1.38	1439	1.48	1500	1.58
2000	907	1.00	990	1.07	1070	1.15	1146	1.23	1220	1.31	1291	1.40	1359	1.49	1425	1.58	1488	1.68	1550	1.77
2200	960	1.24	1043	1.31	1123	1.39	1199	1.47	1273	1.55	1344	1.64	1412	1.73	1478	1.82	1541	1.92	1602	2.01
2400	1015	1.51	1099	1.59	1178	1.66	1255	1.74	1329	1.83	1400	1.92	1468	2.01	1534	2.10	1597	2.19	1658	2.29
2600	1074	1.83	1157	1.90	1237	1.98	1314	2.06	1387	2.14	1458	2.23	1526	2.32	1592	2.41	1656	2.51	1717	2.61
2800	1135	2.18	1218	2.25	1298	2.33	1375	2.41	1448	2.49	1519	2.58	1587	2.67	1653	2.76	1717	2.86	1778	2.96
3000	1198	2.56	1281	2.64	1361	2.71	1438	2.79	1511	2.88	1582	2.96	1651	3.05	1716	3.15	1780	3.24	-	-

Field Supplied Drive

1. Blower performance includes gas heat exchangers and 1" filters. See STATIC RESISTANCE table for additional applications.
2. See RPM SELECTION table to determine desired motor sheave setting and to determine the maximum continuous BHP.
3. kW = BHP x 0.932.

**J03 - A6ZF (3-6 Ton Direct Drive) Side Duct**

UNIT TONNAGE	MOTOR <sup>1</sup> SPEED	AVAILABLE EXTERNAL STATIC PRESSURE - IWG <sup>2</sup>																	
		0.2		0.3		0.4		0.5		0.6		0.7		0.8		0.9		1.0	
		CFM	WATTS	CFM	WATTS	CFM	WATTS	CFM	WATTS	CFM	WATTS	CFM	WATTS	CFM	WATTS	CFM	WATTS	CFM	WATTS
3 <sup>3</sup>	5 (HI)	1574	320	1530	335	1488	349	1451	363	1411	376	1374	390	1331	403	1292	417	1249	430
	4 (MED/HI)	1480	263	1433	276	1389	290	1347	303	1303	316	1257	329	1208	343	1153	358	1080	374
	3 (MED)	1332	208	1286	221	1241	234	1195	246	1146	258	1097	272	1031	288	962	303	919	313
	2 (MED/LOW)	1227	171	1178	183	1129	195	1076	207	1021	220	953	235	891	248	-	-	-	-
	1 (LOW)	1075	130	992	134	930	145	858	158	-	-	-	-	-	-	-	-	-	-
4 <sup>3</sup>	5 (HI)	-	-	2067	696	2027	714	1991	734	1953	749	1910	764	1860	769	1770	743	1621	685
	4 (MED/HI)	1913	539	1877	557	1839	571	1798	585	1764	602	1721	619	1677	638	1621	653	1545	639
	3 (MED)	1722	408	1682	426	1634	438	1597	455	1554	472	1506	490	1450	505	1404	521	1370	536
	2 (MED/LOW)	1621	362	1580	380	1532	391	1502	406	1461	423	1411	440	1359	455	1324	469	1278	485
	1 (LOW)	1332	223	1290	237	1232	247	-	-	-	-	-	-	-	-	-	-	-	-
5 <sup>3</sup>	5 (HI)	2245	883	2247	931	2236	950	2211	964	2171	979	2114	971	2034	940	1948	898	1855	854
	4 (MED/HI)	2135	771	2116	784	2108	808	2078	826	2041	844	2004	859	1955	861	1886	843	1792	806
	3 (MED)	2010	637	1989	656	1975	675	1938	696	1900	715	1867	730	1822	740	1784	756	1716	748
	2 (MED/LOW)	1748	413	1704	432	1669	451	1631	468	1589	479	1551	497	1513	513	1465	523	-	-
	1 (LOW)	1562	327	1529	339	1491	356	-	-	-	-	-	-	-	-	-	-	-	-
6 <sup>3</sup>	5 (HI)	2256	883	2258	931	2247	950	2223	964	2182	979	2125	971	2044	940	1958	898	1864	854
	4 (MED/HI)	2145	771	2127	784	2119	808	2089	826	2051	844	2014	859	1965	861	1896	843	1801	806
	3 (MED)	2020	637	1999	656	1985	675	1947	696	1910	715	1876	730	1832	740	1793	756	-	-
	2 (MED/LOW)	-	-	-	-	-	-	-	-	-	-	-	-	-	-	-	-	-	-
	1 (LOW)	-	-	-	-	-	-	-	-	-	-	-	-	-	-	-	-	-	-

1. Factory set on medium speed tap.
2. Includes allowances for a wet evaporator coil, 1" filters, and the heat exchangers. Refer to STATIC RESISTANCES Table for resistance values.
3. Side Duct application (230 Volts)

**Table 14: J\*\*ZF Blower Performance Bottom Duct**  
**J03ZF (3 Ton Belt Drive) Bottom Duct**

Air Flow (CFM)	Available External Static Pressure - IWG <sup>1</sup>																			
	0.2		0.4		0.6		0.8		1.0		1.2		1.4		1.6		1.8		2.0	
	RPM	BHP	RPM	BHP	RPM	BHP	RPM	BHP	RPM	BHP	RPM	BHP	RPM	BHP	RPM	BHP	RPM	BHP	RPM	BHP
	Field Supplied Drive				Standard Drive Option						High Static Drive Option									
800	613	0.35	724	0.40	826	0.46	920	0.53	1007	0.60	1089	0.67	1165	0.75	1237	0.83	1306	0.91	1372	1.00
1000	640	0.40	751	0.46	853	0.52	947	0.58	1034	0.65	1116	0.73	1192	0.80	1264	0.89	1333	0.97	1399	1.05
1200	669	0.48	779	0.53	881	0.59	975	0.65	1063	0.73	1144	0.80	1220	0.88	1293	0.96	1361	1.04	1427	1.13
1400	702	0.57	812	0.63	914	0.69	1009	0.75	1096	0.82	1177	0.90	1254	0.98	1326	1.06	1394	1.14	1460	1.22
1600	741	0.70	852	0.75	954	0.81	1048	0.88	1135	0.95	1217	1.02	1293	1.10	1365	1.18	1434	1.26	1500	1.35
	Field Supplied Drive																			

1. Blower performance includes gas heat exchangers and 1" filters. See STATIC RESISTANCE table for additional applications.
2. See RPM SELECTION table to determine desired motor sheave setting and to determine the maximum continuous BHP.
3. kW = BHP x 0.932.

**J04ZF (4 Ton Belt Drive) Bottom Duct**

Air Flow (CFM)	Available External Static Pressure - IWG <sup>1</sup>																			
	0.2		0.4		0.6		0.8		1.0		1.2		1.4		1.6		1.8		2.0	
	RPM	BHP	RPM	BHP	RPM	BHP	RPM	BHP	RPM	BHP	RPM	BHP	RPM	BHP	RPM	BHP	RPM	BHP	RPM	BHP
	Field Supplied Drive				Standard Drive Option						High Static Drive Option									
1000	688	0.40	779	0.47	866	0.55	949	0.63	1029	0.71	1107	0.80	1181	0.88	1253	0.97	1322	1.07	1388	1.16
1200	722	0.45	812	0.53	899	0.60	983	0.68	1063	0.76	1140	0.85	1215	0.93	1286	1.03	1355	1.12	1422	1.21
1400	761	0.53	852	0.60	939	0.68	1022	0.76	1103	0.84	1180	0.92	1254	1.01	1326	1.10	1395	1.20	1462	1.29
1600	807	0.65	897	0.72	984	0.79	1068	0.87	1148	0.95	1225	1.04	1300	1.13	1371	1.22	1440	1.31	1507	1.40
1800	856	0.80	947	0.87	1034	0.95	1118	1.02	1198	1.11	1275	1.19	1349	1.28	1421	1.37	1490	1.46	1557	1.56
2000	910	0.99	1001	1.06	1088	1.14	1172	1.22	1252	1.30	1329	1.39	1403	1.47	1475	1.56	1544	1.66	1611	1.75
	Field Supplied Drive																			

1. Blower performance includes gas heat exchangers and 1" filters. See STATIC RESISTANCE table for additional applications.
2. See RPM SELECTION table to determine desired motor sheave setting and to determine the maximum continuous BHP.
3. kW = BHP x 0.932.

**J05ZF (5 Ton Belt Drive) Bottom Duct**

Air Flow (CFM)	Available External Static Pressure - IWG <sup>1</sup>																			
	0.2		0.4		0.6		0.8		1.0		1.2		1.4		1.6		1.8		2.0	
	RPM	BHP	RPM	BHP	RPM	BHP	RPM	BHP	RPM	BHP	RPM	BHP	RPM	BHP	RPM	BHP	RPM	BHP	RPM	BHP
	Field Supplied Drive				Standard Drive Option						High Static Drive Option									
1200	722	0.45	812	0.53	899	0.60	983	0.68	1063	0.76	1140	0.85	1215	0.93	1286	1.03	1355	1.12	1422	1.21
1400	761	0.53	852	0.60	939	0.68	1022	0.76	1103	0.84	1180	0.92	1254	1.01	1326	1.10	1395	1.20	1462	1.29
1600	807	0.65	897	0.72	984	0.79	1068	0.87	1148	0.95	1225	1.04	1300	1.13	1371	1.22	1440	1.31	1507	1.40
1800	856	0.80	947	0.87	1034	0.95	1118	1.02	1198	1.11	1275	1.19	1349	1.28	1421	1.37	1490	1.46	1557	1.56
2000	910	0.99	1001	1.06	1088	1.14	1172	1.22	1252	1.30	1329	1.39	1403	1.47	1475	1.56	1544	1.66	1611	1.75
2200	968	1.23	1059	1.30	1146	1.37	1229	1.45	1309	1.53	1387	1.62	1461	1.71	1533	1.80	1602	1.89	1668	1.99
2400	1029	1.50	1119	1.57	1206	1.65	1290	1.72	1370	1.81	1448	1.89	1522	1.98	1593	2.07	1663	2.16	1729	2.26
2600	1093	1.81	1183	1.88	1270	1.95	1354	2.03	1434	2.11	1511	2.20	1586	2.29	-	-	-	-	-	-
	Field Supplied Drive																			

1. Blower performance includes gas heat exchangers and 1" filters. See STATIC RESISTANCE table for additional applications.
2. See RPM SELECTION table to determine desired motor sheave setting and to determine the maximum continuous BHP.
3. kW = BHP x 0.932.



## JA6ZF (6 Ton Belt Drive) Bottom Duct

Air Flow (CFM)	Available External Static Pressure - IWG <sup>1</sup>																			
	0.2		0.4		0.6		0.8		1.0		1.2		1.4		1.6		1.8		2.0	
	RPM	BHP	RPM	BHP	RPM	BHP	RPM	BHP	RPM	BHP	RPM	BHP	RPM	BHP	RPM	BHP	RPM	BHP	RPM	BHP
	Field Supplied Drive				Standard Drive Option								High Static Drive Option							
1600	807	0.65	897	0.72	984	0.79	1068	0.87	1148	0.95	1225	1.04	1300	1.13	1371	1.22	1440	1.31	1507	1.40
1800	856	0.80	947	0.87	1034	0.95	1118	1.02	1198	1.11	1275	1.19	1349	1.28	1421	1.37	1490	1.46	1557	1.56
2000	910	0.99	1001	1.06	1088	1.14	1172	1.22	1252	1.30	1329	1.39	1403	1.47	1475	1.56	1544	1.66	1611	1.75
2200	968	1.23	1059	1.30	1146	1.37	1229	1.45	1309	1.53	1387	1.62	1461	1.71	1533	1.80	1602	1.89	1668	1.99
2400	1029	1.50	1119	1.57	1206	1.65	1290	1.72	1370	1.81	1448	1.89	1522	1.98	1593	2.07	1663	2.16	1729	2.26
2600	1093	1.81	1183	1.88	1270	1.95	1354	2.03	1434	2.11	1511	2.20	1586	2.29	1657	2.38	1726	2.47	1793	2.57
2800	1159	2.15	1250	2.22	1337	2.29	1420	2.37	1500	2.46	1578	2.54	1652	2.63	1724	2.72	1793	2.81	-	-
3000	1228	2.52	1318	2.59	1405	2.67	1489	2.75	1569	2.83	1646	2.91	1721	3.00	1792	3.09	-	-	-	-
													Field Supplied Drive							

1. Blower performance includes gas heat exchangers and 1" filters. See STATIC RESISTANCE table for additional applications.
2. See RPM SELECTION table to determine desired motor sheave setting and to determine the maximum continuous BHP.
3. kW = BHP x 0.932.

## J03 - JA6ZF (3-6 Ton Direct Drive) Bottom Duct

UNIT TONNAGE	MOTOR <sup>1</sup> SPEED	AVAILABLE EXTERNAL STATIC PRESSURE - IWG <sup>2</sup>																	
		0.2		0.3		0.4		0.5		0.6		0.7		0.8		0.9		1.0	
		CFM	WATTS	CFM	WATTS	CFM	WATTS	CFM	WATTS	CFM	WATTS	CFM	WATTS	CFM	WATTS	CFM	WATTS	CFM	WATTS
3 <sup>3</sup>	5 (HI)	1520	320	1478	335	1438	349	1401	363	1363	376	1327	390	1286	403	1248	417	1207	430
	4 (MED/HI)	1430	263	1384	276	1342	290	1302	303	1259	316	1215	329	1168	343	1114	358	1044	374
	3 (MED)	1287	208	1242	221	1199	234	1155	246	1108	258	1060	272	997	288	930	303	889	313
	2 (MED/LOW)	1185	171	1138	183	1091	195	1041	207	987	220	921	235	862	248	-	-	-	-
	1 (LOW)	1040	130	959	134	900	145	-	-	-	-	-	-	-	-	-	-	-	-
4 <sup>3</sup>	5 (HI)	-	-	1995	696	1957	714	1922	734	1885	749	1844	764	1795	769	1709	743	1566	685
	4 (MED/HI)	1846	539	1812	557	1776	571	1736	585	1704	602	1662	619	1619	638	1566	653	1492	639
	3 (MED)	1662	408	1624	426	1577	438	1542	455	1501	472	1454	490	1400	505	1356	521	1323	536
	2 (MED/LOW)	1566	362	1526	380	1480	391	1450	406	1411	423	1363	440	1312	455	1279	469	1235	485
	1 (LOW)	1287	223	1246	237	1190	247	-	-	-	-	-	-	-	-	-	-	-	-
5 <sup>3</sup>	5 (HI)	2166	883	2169	931	2158	950	2134	964	2095	979	2040	971	1963	940	1881	898	1791	854
	4 (MED/HI)	2060	771	2042	784	2035	808	2006	826	1970	844	1934	859	1888	861	1821	843	1730	806
	3 (MED)	1940	637	1920	656	1907	675	1870	696	1834	715	1802	730	1759	740	1722	756	1657	748
	2 (MED/LOW)	1688	413	1645	432	1611	451	1575	468	1534	479	1498	497	1461	513	-	-	-	-
	1 (LOW)	1509	327	1477	339	-	-	-	-	-	-	-	-	-	-	-	-	-	-
6 <sup>3</sup>	5 (HI)	2177	883	2179	931	2169	950	2145	964	2106	979	2051	971	1973	940	1890	898	1800	854
	4 (MED/HI)	2071	771	2053	784	2045	808	2016	826	1980	844	1944	859	1897	861	1830	843	-	-
	3 (MED)	1950	637	1929	656	1916	675	1880	696	1844	715	1811	730	1768	740	-	-	-	-
	2 (MED/LOW)	-	-	-	-	-	-	-	-	-	-	-	-	-	-	-	-	-	-
	1 (LOW)	-	-	-	-	-	-	-	-	-	-	-	-	-	-	-	-	-	-

1. Factory set on medium speed tap.
2. Includes allowances for a wet evaporator coil, 1" filters, and the heat exchangers. Refer to STATIC RESISTANCES Table for resistance values.
3. Bottom Duct application (230 Volts)

Table 15: Belt Drive RPM Selection

Size (Tons)	Model	HP	Max BHP	Motor Sheave	Blower Sheave	5 Turns Open	4 Turns Open	3 Turns Open	2 Turns Open	1 Turn Open	Fully Closed
J03 (3)	J**ZF	1.5	1.73	1VL44	AK64	805	865	920	980	1035	1095
		1.5	1.73	1VP56	AK66	1115	1170	1225	1280	1335	1390
J04 (4)	J**ZF	1.5	1.73	1VL44	AK56	930	995	1060	1130	1195	1260
		1.5	1.73	1VP56	AK61	1210	1270	1330	1390	1455	1515
J05 (5)	J**ZF	1.5	1.73	1VL44	AK56	930	995	1060	1130	1195	1260
		2	2.3	1VP56	AK56	1325	1395	1460	1525	1590	1660
JA6 (6)	ZF	1.5	1.73	1VL44	AK56	930	995	1060	1130	1195	1260
		3	3.45	1VP56	AK56	1325	1395	1460	1525	1590	1660

\* Field Option Sheave.

**Table 16: Indoor Blower Specifications (Belt Drive)**

Size (Tons)	Motor					Motor Sheave			Blower Sheave			Belt
	HP	RPM	Eff.	SF	Frame	Datum Dia. (in.)	Bore (in.)	Model	Datum Dia. (in.)	Bore (in.)	Model	
J03 (3.0)	1-1/2	1725	0.8	1.15	56	2.8 - 3.8	7/8	1VL44	6.0	1	AK64	A37
	1-1/2	1725	0.8	1.15	56	4.0 - 5.0	7/8	1VP56	6.2	1	AK66	A39
J04 (4.0)	1-1/2	1725	0.8	1.15	56	2.8 - 3.8	7/8	1VL44	5.2	1	AK56	A36
	1-1/2	1725	0.8	1.15	56	4.0 - 5.0	7/8	1VP56	5.7	1	AK61	A38
J05 (5.0)	1-1/2	1725	0.8	1.15	56	2.8 - 3.8	7/8	1VL44	5.2	1	AK56	A36
	2	1725	0.8	1.15	56	4.0 - 5.0	7/8	1VP56	5.2	1	AK56	A38
JA6 (6.0)	1-1/2	1725	0.8	1.15	56	2.8 - 3.8	7/8	1VL44	5.2	1	AK56	A36
	3	1725	0.8	1.15	56	4.0 - 5.0	7/8	1VP56	5.2	1	AK56	A38

**Table 17: Power Exhaust Specifications**

Model	Voltage	Motor			Motor			Fuse Size	CFM @ 0.1 ESP
		HP	RPM <sup>1</sup>	QTY	LRA	FLA	MCA		
2PE04703025	208/230-1-60	1/2	1725	1	23.7	4.4	5.5	8	1350
2PE04703046	460-1-60	1/2	1725	1	4.1	1.7	2.1	5	1350

1. Motors are multi-tapped and factory wired for high speed.

**Checking Supply Air CFM**

The RPM of the supply air blower will depend on the required CFM, the unit accessories or options and the static resistances of both the supply and the return air duct systems. With this information, the motor speed tap (direct drive) or the motor pulley number of turns open (belt drive) can be determined from the Blower Performance Data Tables.

Note the following:

1. The supply air CFM must be within the limitations shown in the Unit Physical Data Table .
2. Pulleys can be adjusted in half turn increments.
3. The tension on the belt should be adjusted as shown in the Belt Adjustment Figure 19.
4. Tighten blower pulley and motor sheave set screws after any adjustments. Re-check set screws after 10-12 hrs run time is recommended.

Start the supply air blower motor. Adjust the resistances in both the supply and the return air duct systems to balance the air distribution throughout the conditioned space. The job specifications may require that this balancing be done by someone other than the equipment installer.

To check the supply air CFM after the initial balancing has been completed:

1. Remove the two 5/16" dot plugs from the blower motor and the filter access panels shown in Figure 8.
2. Insert at least 8" of 1/4 inch tubing into each of these holes for sufficient penetration into the air flow on both sides of the indoor coil.

**NOTE:** The tubes must be inserted and held in a position perpendicular to the air flow so that velocity pressure will not affect the static pressure readings.

3. Using an inclined manometer, determine the pressure drop across a dry evaporator coil. Since the moisture on an

evaporator coil may vary greatly, measuring the pressure drop across a wet coil under field conditions would be inaccurate. To assure a dry coil, the compressors should be deactivated while the test is being run.

4. Knowing the pressure drop across a dry coil, the actual CFM through the unit can be determined from the curve in Pressure Drop vs. Supply Air CFM (Figure 21).

**WARNING**

Failure to properly adjust the total system air quantity and static pressure can result in extensive system damage.

After readings have been obtained, remove the tubes and reinstall the two 5/16" dot plugs that were removed in Step 1.

**NOTE:** De-energize the compressors before taking any test measurements to assure a dry indoor coil.

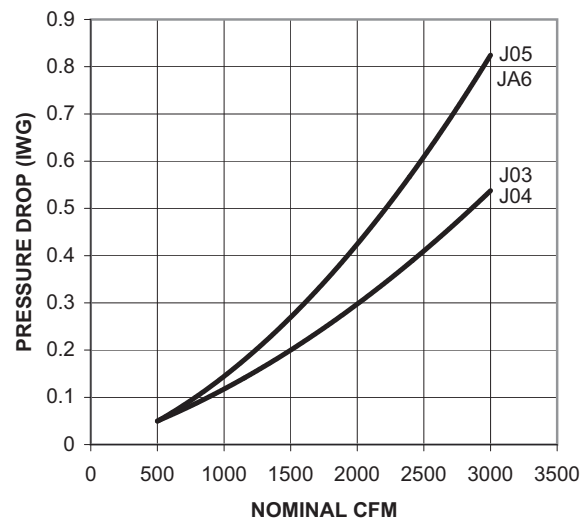

**Figure 21: Pressure Drop Across Coil**

**Table 18: Additional Static Resistance**

Size (Tons)	CFM	Cooling Only <sup>1</sup>	Economizer <sup>2 3</sup>	Electric Heat kW <sup>2</sup>	
				7 - 15	20 - 30
J03 (3.0) J04 (4.0) J05 (5.0) JA6 (6.0)	1000	0.08	0.07	0.04	0.06
	1200	0.10	0.08	0.05	0.07
	1400	0.12	0.09	0.06	0.08
	1600	0.14	0.11	0.07	0.09
	1800	0.16	0.13	0.08	0.11
	2000	0.18	0.15	0.10	0.13
	2200	0.20	0.17	0.12	0.15
	2400	0.23	0.20	0.14	0.17
	2600	0.26	0.23	0.16	0.20
	2800	0.29	0.26	0.19	0.23
3000	0.32	0.30	0.22	0.26	

1. Add these values to the available static resistance in the respective Blower Performance Tables.
2. Deduct these values from the available external static pressure shown in the respective Blower Performance Tables.
3. The pressure drop through the economizer is greater for 100% outdoor air than for 100% return air. If the resistance of the return air duct is less than 0.25 IWG, the unit will deliver less CFM during full economizer operation.

## Operation

### Cooling Sequence Of Operation

For the J\*\*ZF series of units, the thermostat makes a circuit between "R" and "Y1" for the first stage of cooling.

The call is passed to the **Unit Control Board (UCB)**, which then determines whether the requested operation is available and, if so, which components to energize.

For gas heating, the UCB monitors the "W1" call but does not handle the operation of the gas furnace. An ignition control board controls the gas heater operation. For electric heat units, the UCB passes the call to the electric heater. In both cases, when the "W1" call is sensed, the indoor air blower is energized following a specified heating delay.

If at any time a call for both heating and cooling are present, the heating operation will be performed. If operating, the cooling system is halted as with a completion of a call for cooling. Heating always takes priority.

### Continuous Blower

By setting the room thermostat fan switch to "ON," the supply air blower will operate continuously.

### Intermittent Blower

With the room thermostat fan switch set to "AUTO" and the system switch set to either the "AUTO" or "HEAT" settings, the blower is energized whenever a cooling or heating operation is requested. The blower is energized after any specified delay associated with the operation.

When energized, the indoor blower has a minimum run time of 30 seconds. Additionally, the indoor blower has a delay of 10 seconds between operations.

### No Outdoor Air Options

When the thermostat calls for cooling, the low-voltage control circuit from "R" to "Y1" and "G" is completed. The compressor and condenser fan motor are energized. After completing the specified fan on delay for cooling, the UCB will energize the blower motor.

Once the thermostat has been satisfied, it will de-energize Y1. If the compressor has satisfied its minimum run time, the compressor and condenser fan de-energize. Otherwise, the unit operates the cooling system until the minimum run time for the compressor has been completed. After the compressor de-energizes, the blower is stopped following the elapse of the fan off delay for cooling.

To be available, a compressor must not be locked-out due to a high or low-pressure switch or freezestat trip and the anti-short cycle delay (ASCD) must have elapsed.

### Economizer With Single Enthalpy Sensor

When the room thermostat calls for cooling, the low voltage control circuit from "R" to "G" and "Y1" is completed. The UCB energizes the blower motor (if the fan switch on the room thermostat is set in the "AUTO" position) and drives the economizer dampers from fully closed to their minimum position. If the enthalpy of the outdoor air is below the setpoint of the enthalpy controller (previously determined), "Y1" energizes the economizer. The dampers will modulate to maintain a constant supply air temperature as monitored by the discharge air sensor. If the outdoor air enthalpy is above the setpoint, "Y1" energizes the compressor and condenser fan motor only.

Once the thermostat has been satisfied, it will de-energize "Y1". If the compressor has satisfied its minimum run time, the compressor and condenser fan are de-energized. Otherwise, the unit operates the cooling system until the minimum run times for the compressor has been completed. After the compressor de-energizes, the blower is stopped following the elapse of the fan off delay for cooling, and the economizer damper goes to the closed position. If the unit is in continues fan operation the economizer damper goes to the min. position.

### Economizer With Dual Enthalpy Sensors

The operation with the dual enthalpy sensors is identical to the single sensor except that a second enthalpy sensor is mounted in the return air. This return air sensor allows the economizer to choose between outdoor air and return air, whichever has the lowest enthalpy value, to provide maximum operating efficiency.

### Economizer With Power Exhaust

A unit equipped with an economizer (single or dual enthalpy) and a power exhaust operates as specified above with one addition. The power exhaust motor is energized 45 seconds after the actuator position exceeds the exhaust fan set point on the economizer control. When the power exhaust is operating, the second stage of mechanical cooling will not operate. As always, the "R" to "G" connection provides minimum position but does not provide power exhaust operation.

### Motorized Outdoor Air Dampers

This system operation is the same as the units with no outdoor air options with one exception. When the "R" to "G" circuit is complete, the motorized damper drives open to a position set by the thumbwheel on the damper motor. When the "R" to "G" circuit is opened, the damper spring returns fully closed.

### Cooling Operation Errors

Each cooling system is monitored for operation outside of the intended parameters. Errors are handled as described below. All system errors override minimum run times for compressors.

#### High-Pressure Limit Switch

During cooling operation, if a high-pressure limit switch opens, the UCB will de-energize the compressor, initiate the ASCD (Anti-short cycle delay), and stop the condenser fan. If the call for cooling is still present at the conclusion of the ASCD, the UCB will re-energize the compressor.

Should a high-pressure switch open three times within two hours of operation, the UCB will lock-out the associated compressor and flash a code (see Table 29).

#### Low-Pressure Limit Switch

The low-pressure limit switch is not monitored during the initial 30 seconds of a cooling system's operation. For the following 30 seconds, the UCB will monitor the low-pressure switch to ensure it closes. If the low-pressure switch fails to close after the 30-second monitoring phase, the UCB will de-energize the compressor, initiate the ASCD, and stop the condenser fan.

Once the low-pressure switch has been proven (closed during the 30-second monitor period described above), the UCB will monitor the low-pressure limit switch for any openings. If the low-pressure switch opens for greater than 5 seconds, the UCB will de-energize the compressor, initiate the ASCD, and stop the condenser fan.

If the call for cooling is still present at the conclusion of the ASCD, the UCB will re-energize the compressor.

Should a low-pressure switch open three times within one hour of operation, the UCB will lock-out the compressor and flash a code (Table 29).

#### Freezestat

During cooling operation, if a freezestat opens, the UCB will de-energize the compressor, initiate the ASCD, and stop the condenser fan. If the call for cooling is still present at the conclusion of the ASCD, the UCB will re-energize the halted compressor.

Should a freezestat open three times within two hours of operation, the UCB will lock-out the associated compressor and flash a code (Table 29).

#### Low Ambient Cooling

To determine when to operate in low ambient mode, the UCB has a pair of terminals connected to a temperature-activated switch set at 45°F. When the low ambient switch is closed and the thermostat is calling for cooling, the UCB will operate in the low ambient mode.

Low ambient mode operates the compressors in this manner: 10 minutes on, 5 minutes off. The indoor blower is operated throughout the cycle. The 5-minute off period is necessary to defrost the indoor coil.

Low ambient mode always begins with compressor operation. Compressor minimum run time may extend the minutes of compressor operation. The defrost cycle will begin immediately following the elapse of the minimum run time.

When operating in low ambient mode, the UCB will not lockout the compressors due to a freezestat trip. However, a freezestat trip will de-energize the associated compressor. If the call for cooling is still present at the end of the ASCD and the freezestat has closed, the unit will resume operation.

#### Safety Controls

The unit control board monitors the following inputs for each cooling system:

1. A suction line freezestat to protect against low evaporator temperatures due to a low airflow or a low return air temperature, (opens at  $26 \pm 5$  °F and resets at  $38 \pm 5$  °F).
2. A high-pressure switch to protect against excessive discharge pressures due to a blocked condenser coil or a condenser motor failure, (opens at  $625 \pm 25$  psig).
3. A low-pressure switch to protect against loss of refrigerant charge, (opens at  $50 \pm 5$  psig).

The above pressure switches are hard-soldered to the unit. The refrigeration systems are independently monitored and controlled. On any fault, only the associated system will be affected by any safety/preventive action.

The unit control board monitors the temperature limit switch of electric heat units and the temperature limit switch and the gas valve of gas furnace units.

## Compressor Protection

In addition to the external pressure switches, the compressor also has inherent (internal) protection. If there is an abnormal temperature rise in a compressor, the protector will open to shut down the compressor. The UCB incorporates features to minimize compressor wear and damage. An **Anti-Short Cycle Delay (ASCD)** is utilized to prevent operation of a compressor too soon after its previous run. Additionally, a minimum run time is imposed any time a compressor is energized.

The ASCD is initiated on unit start-up and on any compressor reset or lock-out.

## Flash Codes

The UCB will initiate a flash code associated with errors within the system. Refer to UNIT CONTROL BOARD FLASH CODES Table 29.

## Reset

Remove the call for cooling, by raising thermostat setting higher than the conditioned space temperature. This resets any pressure or freestat flash codes.

## Electric Heating Sequence Of Operations

The following sequence describes the operation of the electric heat section.

Single-stage heating (applies only to 5, 7 & 10 kW 230V heaters and to 7, 10, & 15 kW 460V and 575V heaters. All other heaters MUST use a two-stage thermostat):

- Upon a call for heat by the thermostat, the heater sequencer (1S) will be energized. After completing the specified fan on delay for heating, the UCB will energize the blower motor.
- The thermostat will cycle the electric heat to satisfy the heating requirements of the conditioned space.

Two-stage heating (applies only to 15, 20 and 30 kW 230V heaters and 20 and 30 kW heater 460V and 575V heaters.):

- Upon a call for first-stage heat by the thermostat, the heater sequencer (1S) (15, 20, 30 kW 230 volt) and contactor (2M) (20, 30 kW 460 and 575 volt) will be energized. After completing the specified fan on delay for heating, the UCB will energize the blower motor.

If the second stage of heat is required, heater sequencer (2S) (12, 20, 30 kW 230 volt) or contactor (3M) (20, 30 kW 460 and 575 volt) will be energized. After completing the specified fan on delay for heating, the UCB will energize the blower motor.

- The thermostat will cycle the electric heat to satisfy the heating requirements of the conditioned space.

## Electric Heat Operation Errors

### Temperature Limit

If the UCB senses zero volts from the high temperature limit, the indoor blower motor is immediately energized.

This limit is monitored regardless of unit operation status, i.e. the limit is monitored at all times.

If the temperature limit opens three times within one hour, it will lock-on the indoor blower motor and a flash code is initiated (See Table 29).

## Safety Controls

The UCB monitors the temperature limit switch of electric heat units.

The control circuit includes the following safety controls:

### Temperature Limit Switch (TLs)

This control is located inside the heater compartment and is set to open at the temperature indicated in the Electric Heat Limit Setting Table 19. It resets automatically. The limit switch operates when a high temperature condition, caused by inadequate supply air flow occurs, thus shutting down the heater and energizing the blower.

**Table 19: Electric Heat Limit Setting**

Voltage	kW	Temperature Limit Switch	Open Temperature °F
208-1-60	5	1	140
	7	1,3	140
	10	1,2,3	140
	15	2,4,6	140
	20	1,2,3,4,5	140
		6	150
30	1,2,3,4,5,6	150	
230-3-60	5	1,2,3	140
	7	1,2,3	140
	10	1,2,3	150
	15	2,4,6	140
	20	1,2,3,4,5,6	150
		1,3,5	160
30	2,4,6	150	
460-3-60	7	2,4,6	140
	10	2,4,6	140
	15	2,4,6	140
	20	3	160
	30	3	150
	575-3-60	10	2,4,6
15		2,4,6	140
20		5	160
30		5	150

## Flash Codes

The UCB will initiate a flash code associated with errors within the system. Refer to UNIT CONTROL BOARD FLASH CODES Table 29.

## Reset

Remove the call for heating by lowering the thermostat setting lower than the conditioned space temperature. This resets any flash codes.

### Electric Heat Anticipator Setpoints

It is important that the anticipator setpoint be correct. Too high of a setting will result in longer heat cycles and a greater temperature swing in the conditioned space. Reducing the value below the correct setpoint will give shorter “ON” cycles and may result in the lowering of the temperature within the conditioned space. Refer to Table 20 for the required electric heat anticipator setting.

**Table 20: Electric Heat Anticipator Setpoints**

Heater Kw	Voltage	Setting, Amps	
		TH1	TH2
5	230-3-60	0.35	-
7		0.35	-
10		0.35	-
15		0.35	0.19
20		0.35	0.38
30		0.35	0.38
7	460-3-60	0.35	-
10		0.35	-
15		0.35	-
20		0.37	0.29
30		0.37	0.29
10	575-3-60	0.35	-
15		0.35	-
20		0.37	0.29
30		0.37	0.29

### Gas Heating Sequence Of Operations

When there is a W1 call for heat, the heat relay (RW1) is energized by the unit control board (UCB). The RW1-1 contacts immediately close energizing the ignition control board (ICB). The ICB checks the state of the flame sense circuit, the roll out switch, the centrifugal switch and the primary / auxiliary temperature limit switch circuit. If they are in the expected state, then the ICB energizes the draft motor and verifies that the centrifugal switch located on the end of the draft motor closes. After the centrifugal switch closes, a 15 second heat exchanger purging period is completed. After this purging period, the ICB will simultaneously energize the pilot gas valve and the ignition coil. Once the flame sensor senses a pilot flame is present, the ignition coil is de-energized. The ICB checks for pilot flame stability and once the ICB is satisfied that the pilot flame is stable, the main gas valve is energized by the ICB. The UCB will energize the indoor blower after a 45 second delay from the call for heat. The ICB and UCB both monitor the furnace safety devices during the furnace operation. When the call for heat is satisfied, the ICB closes the pilot and main gas valves and performs a 30 second purging of the heat exchanger by continuing the operation of the draft motor. The UCB continues the operation of the indoor blower for a configurable amount of time after the call for heat is satisfied.

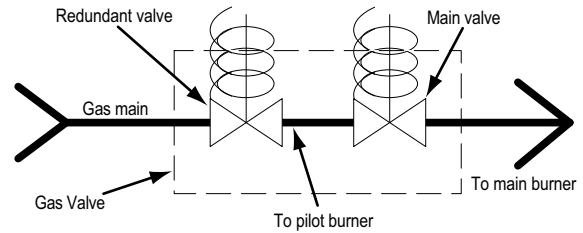

**Figure 22: Gas Valve Piping**

### Two Stage Furnace Only

If a W1 only call for heat from a two stage thermostat is present, then a two stage furnace will start on high fire for 1 minute and then reduce to low fire until the call for heat is satisfied or a W2 call for heat is received. If a W2 call for heat is received while in low fire operation, then the ICB will immediately move to high fire operation. If a W1 and W2 call for heat is present, then the furnace will remain on high fire operation until the W2 call for heat is satisfied.

Automatic staging of a two stage furnace using a single stage thermostat is possible. To achieve automatic staging of a two stage furnace using a single stage thermostat, cut the 440/GY wire that runs from pin 2 of the S3 connector on the (UCB) unit control board to P2-4 on the ignition control board. Cut the wire 1/2" from the S3 mate-n-lock connector. Wire nut or tape off the 1/2" wire. Attach the other end of the 440/GY wire to the R terminal on the UCB, or to the TB1 power strip.

The unit will operate the same as a W1 only call for heat for 10 minutes. If the call for heat is not satisfied in the 10 minutes, then the ICB will move to high fire operation until the W1 call for heat has been satisfied.

### Gas Heat Operation Errors

During furnace operation, the ICB monitors the flame sense circuit, the centrifugal switch, the primary limit switch and the roll out switch. If a signal from any of the inputs moves to a fault state, then the ICB immediately closes the pilot and main gas valves. The ICB will determine the device that is signaling a fault and flash a code for that device. A primary limit trip, centrifugal switch trip or flame sense fault triggers a temporary lock out. An auxiliary limit or a roll out switch trip requires intervention to reset the ICB. The UCB also monitors the primary limit and gas valve.

### Temperature Limits

The primary limit is located such that the temperature sensitive switch can sense the temperature of the heat exchanger tubes. On single or two stage models the limit is mounted just above the inlet of the heat exchanger tubes on the right side. If a primary limit (LS) fault occurs (the primary limit opens due to excessive heat exchanger temperature), then the ICB will flash the appropriate code (Table 30) and monitor the primary limit. The UCB will energize the indoor blower and the ICB will energize the draft motor while the primary limit is open. When the primary limit closes and the call for heat still exists, the ICB will start the ignition sequence

over and the UCB will de-energize the blower for 45 seconds. However, the auxiliary limit is in series with the primary limit and it takes first control. If the excessive heat has been high enough to cause the auxiliary limit (AUX) to open, then the ICB will flash the primary limit code but the furnace will not retry ignition during the same call for heat. The auxiliary limit is of the manual reset type and is mounted in the upper right hand corner of the panel between the burner manifold and the flue gas collector box just behind the draft motor. If the auxiliary switch has opened, then special attention should be paid to the primary limit as it may be faulty as well. However, the auxiliary switch is sized such that multiple trips of the primary limit due to complete blower failure will cause enough heat to build up and trip the auxiliary.

If the primary limit opens three times within one hour, then the UCB will lock on the indoor blower and flash a fault code (Table 29).

### Gas Valve

The UCB monitors the gas valve (GV). Any time the UCB senses voltage at the GV without a call for heat for a continuous five-minute period, the UCB will lock on the indoor blower and a flash code on the UCB is initiated (Table 29). When the UCB no longer senses voltage at the GV the UCB will de-energize the indoor blower after the expiration of the indoor blower heating off delay.

If the voltage has been sensed at the GV for at least 15 seconds during the fan on delay for heating and the UCB no longer senses voltage at the GV (W1 call for heat removed or an ICB fault exists), then the UCB forces the indoor blower on for the indoor blower heating off delay.

The gas valve is of the redundant type. If for any reason the main gas valve fails in the open position, then the redundant valve ahead of the main gas valve will shut off the flow of gas to both the pilot and main gas valves.

### Centrifugal Switch

The centrifugal switch is mounted on the end of the draft motor and it is an integral part of the motor assembly. On a call for heat, the ICB checks the centrifugal switch (CS) for open state before it energizes the draft motor. If it is closed, then the ICB will lock out the furnace and flash a code (Table 30). If open, then the ICB will energize the draft motor and verify that the switch closes before initiating the purging and ignition sequence. If at any time during furnace operation the centrifugal switch opens, then the ICB will de-energize the pilot and main gas valves and monitor the centrifugal switch. If the centrifugal switch closes and the call for heat still exists, then the ICB will retry the purging and ignition sequence.

### Rollout Switch

This temperature sensitive switch is located in the burner vestibule just above the right hand side of the burner assembly. In the event of the flame spilling out into the burner manifold area the rollout switch will open, the ICB will close both the main and pilot gas valves and flash a code (Table 30). The ICB will not retry the ignition sequence during the same call for heat.

### Flame Sense Circuit

The flame sensor is mounted on the left hand side of the burner assembly and is positioned such that the pilot flame surrounds the tip of the sensor. On a call for heat the ICB checks for the flame sense circuit to be open. If open, then the ICB initiates the purging and ignition sequence. Once the pilot flame is present, the ICB monitors the flame sense circuit for pilot flame stability. If the pilot flame is unstable or lost completely, then the ICB will immediately close both the pilot and main gas valves. The ICB will retry the purging and ignition sequence. If the flame is unstable or lost more than 16 times during the same call for heat, then the ICB will lock out furnace operation for 5 minutes.

**Table 21: Single Stage Gas Heat Limit Control Setting**

Unit (Tons)	Capacity, MBH		Limit Control Opens, °F	
	Input	Output	Direct Drive	Belt Drive
3	50	40	240	240
3	100	80	170	210
4	75	60	210	240
4	125	100	165	210
5	100	80	170	210
5	125	100	165	210
6	100	80	170	210
6	125	100	165	210

**Table 22: 2 Stage Gas Heat Limit Control Setting**

Unit (Tons)	1st Stage Capacity		2nd Stage Capacity		Limit Control Opens, °F	
	Input (MBH)	Output (MBH)	Input (MBH)	Output (MBH)	Direct Drive	Belt Drive
3	45	36	75	61	210	240
3	69	55	115	92	200	200
4	45	36	75	61	210	240
4	75	60	125	101	165	210
5	45	36	75	61	210	210
5	75	60	125	101	165	210
6	45	36	75	61	210	210
6	75	60	125	101	165	210

### Flash Codes

The UCB will initiate a flash code associated with errors within the system. Refer to UNIT CONTROL BOARD FLASH CODES Table 29.

### Resets

Remove the call for heating by lowering the thermostat setting lower than the conditioned space temperature. This resets any flash codes.

### Heat Anticipator Setpoints

It is important that the anticipator setpoint be correct. Too high of a setting will result in longer heat cycles and a greater temperature swing in the conditioned space. Reducing the value below the correct setpoint will give shorter "ON" cycles and may result in the lowering of the temperature within the conditioned space.

**Table 23: Gas Heat Anticipator Setpoints**

Gas Valve	Anticipator Setpoints
Honeywell VR8204M	0.60 amp
White-Rogers 36E36	0.54 amp

## Start-up (Cooling)

### Prestart Check List

After installation has been completed:

1. Check the electrical supply voltage being supplied. Be sure that it is the same as listed on the unit nameplate.
2. Set the room thermostat to the off position.
3. Turn unit electrical power on.
4. Set the room thermostat fan switch to on.
5. Check indoor blower rotation.
  - If blower rotation is in the wrong direction. Refer to Phasing Section in general information section.
  - Check blower drive belt tension.
6. Check the unit supply air (CFM). See "CHECKING SUPPLY AIR CFM" on page 50.
7. Measure evaporator fan motor's amp draw.
8. Set the room thermostat fan switch to off.
9. Turn unit electrical power off.

### Operating Instructions

1. Turn unit electrical power on.
2. Set the room thermostat setting to lower than the room temperature.
3. Compressor will energize after the built-in time delay (five minutes).

### Post Start Check List

1. Verify proper system pressures.
2. Measure the temperature drop across the evaporator coil.
3. Measure the system Amperage draw across all legs of 3 phase power wires.
4. Measure the condenser fan amp draw.

### Shut Down

1. Set the thermostat to highest temperature setting.
2. Turn off the electrical power to the unit.

## Start-up (Gas Heat)

### Pre-start Check List

Complete the following checks before starting the unit.

1. Check the type of gas being supplied. Be sure that it is the same as listed on the unit nameplate.

2. Make sure that the vent and combustion air hoods have been properly installed.

### Operating Instructions

#### CAUTION

This furnace is equipped with an intermittent pilot and automatic re-ignition system. DO NOT attempt to manually light the pilot.

### To Light Pilot And Main Burners:

1. Turn "off" electric power to unit.
2. Turn room thermostat to lowest setting.
3. Turn gas valve knob or switch to "on" position.
4. Turn "on" electric power to unit.
5. Set room thermostat to desired temperature. (If thermostat "set" temperature is above room temperature, pilot burner ignition will occur and, after an interval to prove pilot flame, main burners will ignite).

### To Shut Down:

1. Turn "off" electric power to unit.
2. Depress knob of gas valve while turning to "off" position or position the switch to the "off" position.

### Post-Start Check List (Gas)

After the entire control circuit has been energized and the heating section is operating, make the following checks:

1. Check for gas leaks in the unit piping as well as the supply piping.

#### WARNING

#### FIRE OR EXPLOSION HAZARD

Failure to follow the safety warning exactly could result in serious injury, death or property damage.

Never test for gas leaks with an open flame. Use a commercially available soap solution made specifically for the detection of leaks to check all connections. A fire or explosion may result causing property damage, personal injury or loss of life.

2. Check for correct manifold gas pressures. See "Checking Gas Input" on page 58.
3. Check the supply gas pressure. It must be within the limits shown on rating nameplate. Supply pressure should be checked with all gas appliances in the building at full fire. At no time should the standby gas line pressure exceed 13", nor the operating pressure drop below 5.0" for natural gas units. If gas pressure is outside these limits, contact the local gas utility for corrective action.



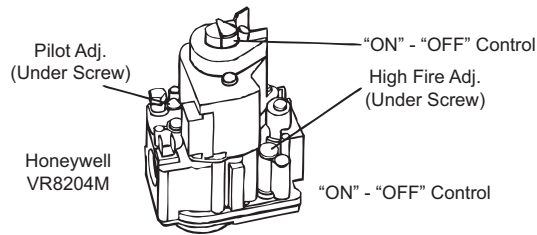

**Figure 23: Typical Single Stage Gas Valves**

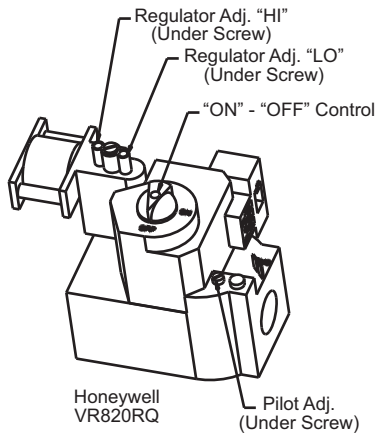

**Figure 24: Typical 2 Stage Gas Valves**

### Manifold Gas Pressure Adjustment

Adjustments to the high-fire and low-fire (2 stage) gas flow may be made by turning the pressure regulator adjusting screws on the automatic gas valve.

Adjust as follows:

1. Remove the adjustment screw cap(s) on the regulator.
2. To decrease the gas pressure, turn the adjusting screw counterclockwise.
3. To increase the gas pressure, turn the adjusting screw clockwise.
4. Replace adjustment screw caps.

**NOTE:** The factory set high-fire manifold pressure for these furnaces is 3.50 IWG. The actual manifold pressure depends on the local fuel heating value.

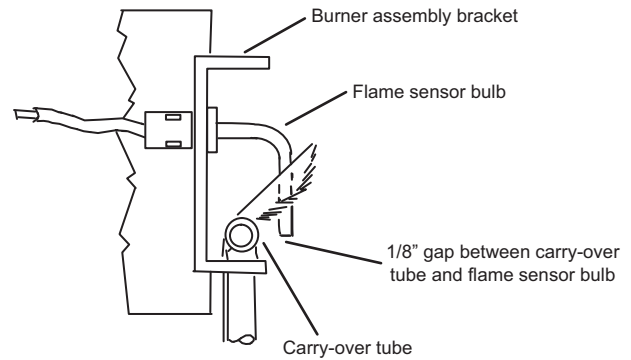

**Figure 25: Proper Flame Adjustment**

### Pilot Checkout

The pilot flame should envelope the end of the flame sensor. To adjust pilot flame, (1) remove pilot adjustment cover screw, (2) increase or decrease the clearance for air to the desired level, (3) be sure to replace cover screw after adjustment to prevent possible gas leakage.

Put the system into operation and observe through complete cycle to be sure all controls function properly.

### Burner Instructions

To check or change burners, pilot or orifices, CLOSE MAIN MANUAL SHUT-OFF VALVE AND SHUT OFF ALL ELECTRIC POWER TO THE UNIT.

1. Remove the screws holding either end of the manifold to the burner supports.
2. Open the union fitting in the gas supply line just upstream of the unit gas valve and downstream from the main manual shut-off valve.
3. Remove the gas piping closure panel.
4. Disconnect wiring to the gas valves and spark ignitors. Remove the manifold-burner gas valve assembly by lifting up and pulling back.

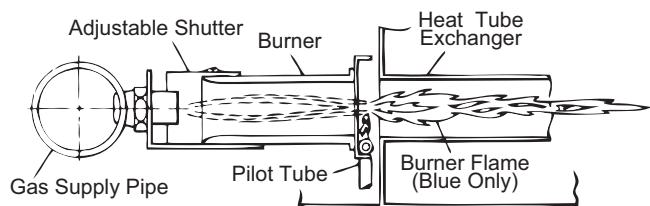

**Figure 26: Typical Flame Appearance**

Burners are now accessible for service.

Reverse the above procedure to replace the assemblies. Make sure that burners are level and seat at the rear of the heat exchanger.

### Burner Air Shutter Adjustment

Adjust burner shutters so no yellow flame is observed in the heat exchanger tubes.

## Checking Gas Input

### Natural Gas

1. Turn off all other gas appliances connected to the gas meter.
2. With the furnace turned on, measure the time needed for one revolution of the hand on the smallest dial on the meter. A typical gas meter usually has a 1/2 or a 1 cubic foot test dial.
3. Using the number of seconds for each revolution and the size of the test dial increment, find the cubic feet of gas consumed per hour from the Gas Rate - Cubic Feet Per Hour (Table 24).

If the actual input is not within 5% of the furnace rating (with allowance being made for the permissible range of the regulator setting), replace the orifice spuds with spuds of the proper size.

**NOTE:** To find the Btu input, multiply the number of cubic feet of gas consumed per hour by the Btu content of the gas in your particular locality (contact your gas company for this information - it varies widely from city to city.)

**Table 24: Gas Rate-Cubit Feet per Hour<sup>1</sup>**

Seconds for One Rev.	Size of Test Dial	
	1/2 cu. ft.	1 cu. ft.
10	180	360
12	150	300
14	129	257
16	113	225
18	100	200
20	90	180
22	82	164
24	75	150
26	69	138
28	64	129
30	60	120
32	56	113
34	53	106
36	50	100
38	47	95
40	45	90
42	43	86
44	41	82
46	39	78
48	37	75
50	36	72
52	35	69
54	34	67
56	32	64
58	31	62
60	30	60

1. By actual measurement, it takes 38 seconds for the hand on the 1-cubic foot dial to make a revolution with a 100,000 Btuh furnace running. Using this information, located 38 seconds in the first column in the table above. Read across to the column headed "1 Cubic Foot", where you will see that 95 cubic feet of gas per hour are consumed by the furnace at that rate. Multiply 95 X 1050 (the Btu rating of the gas obtained from the local gas company). The result is 99,750 Btuh, which is close to the 100,000 Btuh rating of the furnace.

## Adjustment Of Temperature Rise

The temperature rise (or temperature difference between the return air and the heated air from the furnace) must lie within the range shown on the rating plate and the data in the Gas Heat Application Table 10.

$$CFM = \frac{\text{Btuh Input} \times 0.8}{108 \times \text{°F Temp. Rise}}$$

After the temperature rise has been determined, the cfm can be calculated as follows:

After about 20 minutes of operation, determine the furnace temperature rise. Take readings of both the return air and the heated air in the ducts (about six feet from the furnace) where they will not be affected by radiant heat. Increase the blower cfm to decrease the temperature rise; decrease the blower cfm to increase the rise. Refer to the In Door Blower Specification Table 16.

## Charging The Unit

ZF036 and 048 units use Thermal Expansion Devices; ZF060 Units use a Fixed Orifice for Refrigerant Control. Charge all units to 12° subcooling.

## Troubleshooting

### ⚠ WARNING

Troubleshooting of components may require opening the electrical control box with the power connected to the unit. **Use extreme care when working with live circuits!** Check the unit nameplate for the correct line voltage and set the voltmeter to the correct range before making any connections with line terminals.

When not necessary, shut off all electric power to the unit prior to any of the following maintenance procedures so as to prevent personal injury.

### ⚠ CAUTION

Label all wires prior to disconnection when servicing controls. Wiring errors can cause improper and dangerous operation which could cause injury to person and/or damage unit components. Verify proper operation after servicing.

On calls for cooling, if the compressors are operating but the supply air blower motor does not energize after a short delay (the room thermostat fan switch is in the "AUTO" position).

1. Turn the thermostat fan switch to the ON position. If the supply air blower motor does not energize, go to Step 3.

2. If the blower motor runs with the fan switch in the ON position but will not run after the compressor has energized when the fan switch is in the AUTO position, check the room thermostat for contact between R and G in the AUTO position during calls for cooling.
3. If the supply air blower motor does not energize when the fan switch is set to ON, check that line voltage is being supplied to the contacts of the M2, contactor, and that the contactor is pulled in. Check for loose wiring between the contactor and the supply air blower motor.
4. If M2 is pulled in and voltage is supplied to M2, lightly touch the supply air blower motor housing. If it is hot, the motor may be off on internal protection. Cancel any thermostat calls and set the fan switch to AUTO. Wait for the internal overload to reset. Test again when cool.
5. If M2 is not pulled in, check for 24 volts at the M2 coil. If 24 volts are present at M2 but M2 is not pulled in, replace the contactor.
6. Failing the above, if there is line voltage supplied at M2, M2 is pulled in, and the supply air blower motor still does not operate, replace the motor.
7. If 24 volts is not present at M2, check that 24 volts is present at the UCB supply air blower motor terminal, "FAN". If 24 volts is present at the FAN, check for loose wiring between the UCB and M2.
8. If 24 volts is not present at the "FAN" terminal, check for 24 volts from the room thermostat. If 24 volts are not present from the room thermostat, check for the following:
  - a. Proper operation of the room thermostat (contact between R and G with the fan switch in the ON position and in the AUTO position during operation calls).
  - b. Proper wiring between the room thermostat and the UCB.
  - c. Loose wiring from the room thermostat to the UCB.
9. If 24 volts is present at the room thermostat but not at the UCB, check for proper wiring between the thermostat and the UCB, i.e. that the thermostat G terminal is connected to the G terminal of the UCB, and for loose wiring.
10. If the thermostat and UCB are properly wired, replace the UCB.

On a call for cooling, the supply air blower motor is operating but the compressor is not (the room thermostat fan switch is in the "AUTO" position).

1. If installed, check the position of the economizer blades. If the blades are open, the economizer is providing free cooling and the compressors will not immediately operate. If both stages of cooling are requested simultaneously and the economizer provides free cooling, following a short delay the compressor will be energized unless it is locked out, unless this option has been disabled through computer communications.
2. If no economizer is installed or the economizer is not opening to provide free cooling and the compressor does not energize on a call for cooling, check for line voltage at

the compressor contactor, M1, and that the contactor is pulled in. Check for loose wiring between the contactor and the compressor.

3. If M1 is pulled in and voltage is supplied at M1, lightly touch the compressor housing. If it is hot, the compressor may be off on inherent protection. Cancel any calls for cooling and wait for the internal overload to reset. Test again when cool.
  4. If M1 is not pulled in, check for 24 volts at the M1 coil. If 24 volts are present and M1 is not pulled in, replace the contactor.
  5. Failing the above, if voltage is supplied at M1, M1 is pulled in, and the compressor still does not operate, replace the compressor.
  6. If 24 volts is not present at M1, check for 24 volts at the UCB terminal, C1. If 24 volts is present, check for loose wiring between C1 and the compressor contactor.
  7. If 24 volts is not present at the C1 terminal, check for 24 volts from the room thermostat at the UCB Y1 terminal. If 24 volts is not present from the room thermostat, check for the following:
    - a. 24 volts at the thermostat Y1 terminal
    - b. Proper wiring between the room thermostat and the UCB, i.e. Y1 to Y1, Y2 to Y2
    - c. Loose wiring from the room thermostat to the UCB.
  8. If 24 volts is present at the UCB Y1 terminal, the compressor may be out due to an open high-pressure switch, low-pressure switch, or freezestat. Check for 24 volts at the HPS1, LPS1, and FS1 terminals of the UCB. If a switch has opened, there should be a voltage potential between the UCB terminals, e.g. if LPS1 has opened, there will be a 24-volt potential between the LPS1 terminals.
  9. If 24 volts is present at the UCB Y1 terminal and none of the protection switches have opened, the UCB may have locked out the compressor for repeat trips. The UCB should be flashing an alarm code. If not, press and release the ALARMS button on the UCB. The UCB will flash the last five alarms on the LED. If the compressor is locked out, cancel any call for cooling. This will reset any compressor lock outs.
- NOTE:** While the above step will reset any lockouts, the compressor may be held off for the ASCD. See the next step.
10. If 24 volts is present at the UCB Y1 terminal and none of the switches are open and the compressor is not locked

out, the UCB may have the compressor in an ASCD. Check the LED for an indication of an ASCD cycle. The ASCD should time out within 5 minutes. Press and release the TEST button to reset all ASCDs.

11. If 24 volts is present at the UCB Y1 terminal and the compressor is not out due to a protective switch trip, repeat trip lock out, or ASCD, the economizer terminals of the UCB may be improperly wired. Check for 24 volts at the Y1 "OUT" terminal of the UCB. If 24 volts is present, trace the wiring from Y1 "OUT" for incorrect wiring. If 24 volts is not present at the Y1 "OUT" terminal, the UCB must be replaced.
12. *For units without economizers:* If 24 volts is present at the Y1 OUT terminal, check for 24 volts at the Y1 "ECON" terminal. If 24 volts is not present, check for loose wiring from the Y1 "OUT" terminal to the Mate-N-Lock plug, the jumper in the Mate-N-Lock plug, and in the wiring from the Mate-N-Lock plug to the Y1 "ECON" terminal.
13. *For units with economizers:* If 24 volts is present at the Y1 "OUT" terminal, check for 24 volts at the Y1 "ECON" terminal. If 24 volts is not present, check for loose wiring from the Y1 "OUT" terminal to the Mate-N-Lock plug, a poor connection between the UCB and economizer Mate-N-Lock plugs, loose wiring from the Mate-N-Lock plug to the economizer, back to the Mate-N-Lock plug, and from the Mate-N-Lock plug to the Y1 "ECON" terminal. If nothing is found, the economizer actuator may have faulted and is failing to return the 24-volt "call" to the Y1 "ECON" terminal even though the economizer is not providing free cooling. To test, disconnect the Mate-N-Locks and jumper between the WHITE and YELLOW wires of the UCB's Mate-N-Lock plug. If the compressor energizes, there is a fault in the economizer wiring or actuator.
14. The UCB can be programmed to lock out compressor operation during free cooling and in low ambient conditions. These options are not enabled by default. Local distributors can test the UCB for this programming.
 

For units with factory installed economizers, the UCB is programmed to lock out compressor operation when the LAS set point is reached.

For units without factory installed or with field installed economizers, the UCB allows compressor operation all the time. This programming can be checked or changed by the local distributor.
15. If none of the above correct the error, replace the UCB.

## Normal Operating Pressures

Table 25: J03ZF (3.0 Ton) Operating Pressures

Air Flow Indoor Db/Wb	Indoor DB/WB	Outdoor DB	Suction Pressure	Suction Temp.	Liquid Pressure	Liquid Temp.	Delta T Db	Entering Evap Db	Leaving Evap Db	Compressor Amps
300 Cfm/Ton	80/67	95	138	55	344	104	-21	80	59	11.7
		85	133	61	300	94	-23	80	57	10.5
		75	127	67	261	83	-25	80	55	9.3
400 Cfm/Ton	80/62	95	137	48	344	104	-24	80	56	11.7
		85	132	56	299	94	-25	80	55	10.5
		75	127	63	254	83	-27	80	53	9.3
400 Cfm/Ton	80/67	95	143	61	341	102	-19	80	61	10.7
		85	135	65	302	92	-20	80	60	10.6
		75	127	69	260	83	-21	80	59	10.5
400 Cfm/Ton	80/72	95	150	70	350	102	-14	80	65	12.0
		85	144	71	306	90	-16	80	64	10.6
		75	137	72	263	77	-17	80	63	9.2
400 Cfm/Ton	75/63	95	134	52	341	103	-18	75	57	12.4
		85	127	57	302	92	-19	75	56	11.4
		75	122	58	260	81	-20	75	55	9.9

Table 26: J04ZF (4.0 Ton) Operating Pressures

Air Flow Indoor Db/Wb	Indoor DB/WB	Outdoor DB	Suction Pressure	Suction Temp.	Liquid Pressure	Liquid Temp.	Delta T Db	Entering Evap Db	Leaving Evap Db	Compressor Amps
300 Cfm/Ton	80/67	95	141	108	356	100	-22	80	58	14.4
		85	134	105	311	88	-23	80	57	13.0
		75	127	102	266	76	-25	80	55	11.6
400 Cfm/Ton	80/62	95	140	109	353	101	-24	80	56	14.2
		85	132	104	308	89	-25	80	55	12.9
		75	124	99	264	77	-26	80	54	11.6
400 Cfm/Ton	80/67	95	146	111	361	99	-19	80	61	14.5
		85	140	108	316	87	-20	80	60	13.1
		75	134	104	272	75	-21	80	59	11.7
400 Cfm/Ton	80/72	95	152	114	366	97	-16	80	64	14.8
		85	145	109	322	86	-17	80	63	13.4
		75	138	103	278	75	-19	80	61	12.0
400 Cfm/Ton	75/63	95	137	102	352	100	-19	75	56	16.2
		85	132	100	306	87	-20	75	55	14.9
		75	127	101	267	76	-20	75	54	13.4

Table 27: J05ZF (5.0 Ton) Operating Pressures

Air Flow Indoor Db/Wb	Indoor DB/WB	Outdoor DB	Suction Pressure	Suction Temp.	Liquid Pressure	Liquid Temp.	Delta T Db	Entering Evap Db	Leaving Evap Db	Compressor Amps
300 Cfm/Ton	80/67	95	141	69	384	98	-22	80	58	18.1
		85	136	74	339	87	-23	80	57	16.6
		75	131	78	294	75	-24	80	56	15.1
400 Cfm/Ton	80/62	95	138	70	376	98	-24	80	56	17.8
		85	132	73	331	86	-25	80	55	16.3
		75	127	76	286	75	-26	80	54	14.8
400 Cfm/Ton	80/67	95	146	74	390	97	-19	80	61	18.4
		85	140	76	347	86	-20	80	60	16.9
		75	135	78	305	76	-21	80	59	15.4
400 Cfm/Ton	80/72	95	153	78	404	97	-16	80	64	19.1
		85	148	79	361	86	-15	80	65	17.5
		75	143	79	318	74	-15	80	65	15.9
400 Cfm/Ton	75/63	95	136	65	381	98	-19	75	56	20.1
		85	132	69	337	86	-20	75	55	18.7
		75	127	70	298	75	-20	75	55	17.2

**Table 28: JA6ZF (6.0 Ton) Operating Pressures**

Air Flow Indoor Db/Wb	Indoor DB/WB	Outdoor DB	Suction Pressure	Suction Temp.	Liquid Pressure	Liquid Temp.	Delta T Db	Entering Evap Db	Leaving Evap Db	Compressor Amps
300 Cfm/Ton	80/67	95	130	86	384	97	-21	80	59	14.1
		85	125	85	336	86	-22	80	58	13.1
		75	119	83	293	76	-23	80	57	12.1
400 Cfm/Ton	80/62	95	127	88	379	97	-22	80	58	14.1
		85	122	86	331	86	-23	80	57	12.8
		75	117	84	287	75	-23	80	57	11.8
400 Cfm/Ton	80/67	95	134	90	389	97	-18	80	62	14.3
		85	129	88	340	86	-18	80	62	13.1
		75	123	86	296	75	-19	80	61	12.1
400 Cfm/Ton	80/72	95	139	93	399	96	-13	80	67	14.7
		85	133	90	348	85	-14	80	67	13.4
		75	127	88	303	75	-15	80	65	12.4
400 Cfm/Ton	75/63	95	126	83	384	98	-17	75	58	16.4
		85	122	81	337	87	-18	75	57	15.2
		75	117	83	298	75	-19	75	56	14.7

**Gas Heat Troubleshooting Guide**

**▲ WARNING**

Troubleshooting of components may require opening the electrical control box with the power connected to the unit. **Use extreme care when working with live circuits!** Check the unit nameplate for the correct line voltage and set the voltmeter to the correct range before making any connections with line terminals.

When not necessary, shut off all electric power to the unit prior to any of the following maintenance procedures so as to prevent personal injury.

**▲ CAUTION**

Label all wires prior to disconnection when servicing controls. Wiring errors can cause improper and dangerous operation, which could cause injury to person and/or damage unit components. Verify proper operation after servicing.

**▲ WARNING**

The furnace may shut down on a high temperature condition during the procedure. If this occurs, the UCB energize the supply air blower motor until the high temperature limit has reset. Caution should be used at all times as the supply air blower may energize regardless of the room thermostat fan switch position.

Before beginning symptomatic troubleshooting activities read the flash code LEDs on the unit control board (UCB) and the ignition control board (ICB). Fault codes have a quick sequence

of flashes indicating the flash code number followed by a pause with the LED off. The ICB flash codes are repeated until the fault is cleared. The ICB monitors itself, the centrifugal switch, lockout due to > 16 pilot flame losses, primary limit, rollout and a flame present when the ICB expects no flame.

With power applied to the unit, if the LED on the ICB is flashing the heartbeat and the furnace will not operate, then proceed to the symptomatic troubleshooting section. If the ICB LED is not flashing, then perform the ICB troubleshooting procedures. If the ICB has a flash code other than the heartbeat, then determine the flash code and locate its troubleshooting procedures in the flash code troubleshooting section. Refer to Table 30 for flash code identification and component causing fault.

**Flash Code Troubleshooting**

Power to the unit should be interrupted during the troubleshooting of individual components unless otherwise indicated. All troubleshooting procedures assume the unit is wired per the wiring diagram. If there is any indication the unit has been previously repaired, then the first priority is to verify that the furnace is wired per the wiring diagram. Miss-wired units will give false flash codes.

**Ignition Control Board**

The ICB controls the ignition of the pilot, the opening and closing of the gas valves and the operation of the draft (inducer) motor. It also monitors all the furnace safety components.

If the ICB LED is on steady, then verify the wiring of the unit to the wiring diagram and if ok, then replace the ICB. If the unit has power and the ICB LED is not flashing, then remove the 3 pin connector (single stage gas heat) or 4 pin connector (2 stage gas heat) from the ICB. Measure the control voltage between terminals 1 and 2 of the wiring harness connector. The control voltage must be between 18 and 30 volts. If control voltage is not present, then check the 3.2A circuit breaker to verify that the circuit breaker has control voltage on both input and output terminals. If control voltage is present on the input and not the output of the circuit breaker, then reset or replace

the circuit breaker as necessary. If control voltage is present on both sides of the circuit breaker, then check the power and common wires between the unit control box and the ICB and repair as necessary. If the control voltage is present, then verify the cleanliness of the harness and the ICB connector, clean if necessary and reconnect the wiring harness to the ICB and observe ICB LED. If it now flashes the heartbeat, then the fault was a bad connection between the harness connector and the ICB connector or a broken wire exists in the harness. With the harness connected to the ICB, gently move the wires in the harness while observing the ICB LED. If heartbeat is steady, then verify proper operation of the furnace. If the ICB does not flash the heartbeat, then gently move the wires in the harness connector while observing the ICB LED. If you get any flashes of the ICB LED, then there is still a bad connection or a broken wire. If no flashes are seen while gently moving the wires with the harness connected to the ICB, then replace the ICB and verify proper operation of the furnace.

### Centrifugal Switch

The centrifugal switch is an integral part of the draft motor. The centrifugal switch closes when the motor speed increases to ~2500 rpm and opens when the motor speed descends to ~2000 rpm.

If a flash code indicates the centrifugal switch is causing a fault, then

1. If the flash code indicates the switch is open with the draft (inducer) motor on (flash code 2), then
  - a. Disconnect power to the unit. Using a screw driver, spin the draft motor blower wheel. If bound or dragging, then visually inspect the draft motor blower wheel area for debris. If debris is present, then clear debris and verify proper furnace operation. If clear, then replace the draft motor and verify proper furnace operation.
  - b. Restore power to unit and induce a call for heat. Measure the voltage across the two draft motor leads (white and red on single stage models and white and black on two stage models). If it is less than 177 volts, then check and repair the power circuit to the draft motor. If the voltage is greater than 176 volts and the draft motor is not turning, then disconnect power and draft motor power leads. Measure the resistance of the draft motor windings. If an open circuit exists in the motor, then replace the draft motor. If the voltage is greater than 176 volts and the motor is turning, then check the centrifugal switch wiring between the ICB and the draft motor. If ok, then disconnect power to the unit and place the gas valve in the off position. Prepare to temporarily jumper the wires connected to terminals 3 and 8 of the ICB 9 pin harness connector by disconnecting the draft motor leads from the 9 pin harness. Restore the power to the unit and induce a call for heat. Jumper wires 3 and 8. If the ignition sequence is started after 15 seconds (audible sparking of the igniter), then replace the draft motor reconnecting the centrifugal switch wiring per the wiring diagram. If not, then replace the ICB, remove the jumper and reconnect

the centrifugal switch wiring per the wiring diagram.

Place the gas valve in the on position and verify proper furnace operation.

2. If the flash code indicates the switch is closed with the draft (inducer) motor off (flash code 3), then disconnect the 9 pin connector from the ICB and measure the continuity of the centrifugal switch with a battery powered test light or an ohm meter between terminals 3 and 8 of the harness connector. If a closed circuit is indicated, then check the wiring between the ICB and the draft motor. If the wiring is not shorted together, then replace the draft motor. If an open circuit is indicated, then reconnect the 9 pin wiring harness to the ICB and remove power to the unit for at least 20 seconds. Restore power to the unit. If the ICB continues to flash a code 3, then replace the ICB.

### Pilot Flame Lockout

The ICB counts the number of flame losses during the same call for heat. If more than 16 flame losses occur within the same call for heat, then the control temporarily locks out furnace operation for 5 minutes (flash code 5). If the call for heat remains after the 5 minutes, then the ICB will retry the ignition sequence. The flame losses can be due to low inlet pressure, debris around flame sensor, plugged pilot burner, soot on the surface of the flame sensor or misadjusted pilot pressure. Remove the power to the unit for 20 seconds and then restore power to the unit. Induce a call for heat and observe the pilot flame in the flame sensor area to determine the best course of action.

1. If the flame is strong and stable in the flame sensor area, then verify the position of the flame sensor per the start up procedures. If ok, then remove the flame sensor and check the cleanliness of the electrode. If clean, then replace the flame sensor and adjust pilot per the start up procedures. If not clean, then clean, reinstall and adjust pilot per the start up procedures.
2. If the flame is weak or unstable in the flame sensor area, then verify the gas inlet pressure. If gas inlet pressure is above the minimum inlet pressure stated on unit data label, then adjust the pilot pressure per the start up procedures. If the pilot cannot be adjusted to obtain a strong and stable flame in the flame sensor area, then remove the burner assembly and verify the pilot burner assembly is open internally and the holes in the burner are clean. Check the pilot orifice size to the unit data plate and the cleanliness of the pilot orifice. Verify that the flame sensor electrode is clean and is adjusted properly. After cleaning or replacement of the pilot assembly components, reinstall the burner assembly and adjust pilot per the start up procedure.

### Primary or Aux Temperature Limit

The temperature limits limit the temperature in the furnace to a safe level. If a temperature higher than the preset limit is achieved due to low or no air flow through the furnace, then the temperature limits opens and the ICB closes the gas valve and flashes code 6. The primary limit is automatic reset type while the auxiliary limit is manual reset type. If either one opens, then the ICB removes power to the gas valve and the UCB

energizes the indoor blower until the primary limit automatically resets or the auxiliary limit is manually reset. Verify adequate air flow through the furnace. If air flow is nonexistent or weak, then troubleshoot and repair the conditioned space air circulation system as necessary. Reset the auxiliary limit and verify proper operation of the furnace. If airflow is normal, then verify the gas input rate to the furnace following the start up procedures (auxiliary limit must be reset before the furnace will operate). If after verifying the circulating air system, the input rate to the furnace and that the air temperature rise through the furnace is within the rise range on the unit data plate the flash code still exists, then set the gas valve to the off position and temporarily apply control voltage (~24 volts) to pin 9 of the 9 pin ICB connector. With power applied to the unit, if the ICB LED continues to flash a code 6, then replace the ICB and return unit to operation (you must remove the temporary voltage to pin 9 before the gas valve is turned on). If the ICB LED flashes a heartbeat, then replace the limit that is opening, remove the temporary voltage applied to pin 9, turn on the gas valve, restart the furnace and verify proper operation of the furnace.

### Rollout Switch

The rollout switch is installed to protect the furnace from damage due to excessive heat in the burner area. There are 4 main reasons the rollout switch will open (flash code 7) due to excessive heat in the burner area. You must remove power to the unit for 20 seconds to reset the ICB.

1. A blocked flue outlet is the most common cause for the rollout switch to open. Check the flue outlet for debris and clear if necessary.
2. Loose blower wheel on draft motor. Verify that the blower wheel is securely fastened to the draft motor shaft.
3. Unit operating outside the air temperature rise range stated on the unit data plate. Either the air flow through the furnace is not sufficient or the gas input rate to the furnace exceeds the recommended rate. Verify both conditions are within the published ranges.
4. Cracked heat exchanger tube(s). If a heat exchanger tube or tubes is cracked, then the flow through the heat exchanger is restricted and the flame will either roll out of the tube inlet or heat will build to an abnormal level in the burner area. This can usually be determined by observing burner flame with and without indoor blower operation. If the flame changes when the blower is running compared to when it is not, then visually inspect the heat exchanger tubes.

If all of the above are found to be in good condition or within the operating ranges, then set the gas valve to the off position and temporarily apply control voltage (~24 volts) to pin 6 of the 9 pin ICB connector. With power applied to the unit, if the ICB LED continues to flash a code 7, then replace the ICB and return unit to operation (you must remove the temporary voltage to pin 6 before the gas valve is turned on). If the ICB LED flashes a heartbeat, then replace the rollout switch, remove the temporary voltage applied to pin 6, turn on the gas valve, restart the furnace and verify proper operation of the furnace.

### Unexpected Flame Presence

If a flame is present without a call for heat (flash code 8), then the ICB will continue operation of the draft motor and the UCB will call for indoor operation when either of the temperature limit opens. If the unit is correctly wired and there is not a call for heat, then check for control voltage to the gas valve. If control voltage exists at the gas valve, then replace the ICB. If voltage is not present at the gas valve, then replace the gas valve.

### Gas Valve Stuck Off or On

If the pilot and/or the main valves are sensed to be off more than 1 second when commanded to be on, the control will shut off all outputs and enter a hard lockout (flash code 9). Likewise, if the pilot and/or the main valves are sensed to be on more than 1 second when commanded to be off, the control will shut off all outputs and enter a hard lockout (flash code 9). The control will not respond to thermostat demands during a hard lockout. The only way to recover from a hard lockout is to remove and reapply 24VAC power to the control.

### Flame Sense Circuit Failure

If the control detects an internal hardware failure in the flame sense circuit, it shuts off all outputs and enters a hard lockout (flash code 10). The control will not respond to thermostat demands during a hard lockout. The only way to recover from a hard lockout is to remove and reapply 24VAC power to the control. If problem persists after removal and reapplication of 24VAC power, the board may need to be replaced.

### Symptomatic Troubleshooting

On calls for heating, the draft motor operates and the furnace lights but the supply air blower motor does not energize after a short delay (the room thermostat fan switch is in "AUTO" position).

1. Place the thermostat fan switch in the "ON" position. If the supply air blower motor energizes, go to Step 10.
2. If the supply air blower motor does not energize when the fan switch is set to "ON," check that line voltage is being supplied to the contacts of the M2 contactor, and that the contactor is pulled in. Check for loose wiring between the contactor and the supply air blower motor.
3. If M2 is pulled in and voltage is supplied at M2, lightly touch the supply air blower motor housing. If it is hot, the motor may be off on inherent protection. Cancel any thermostat calls and set the fan switch to "AUTO", wait for the internal overload to reset. Test again when cool.
4. If M2 is not pulled in, check for 24 volts at the M2 coil. If 24 volts is present at M2 but M2 is not pulled in, replace the contactor.
5. Failing the above, if there is line voltage supplied at M2, M2 is pulled in, and the supply air blower motor still does not operate, replace the motor.
6. If 24 volts is not present at M2, check that 24 volts is present at the supply air blower motor terminal on the UCB.



If 24 volts is present at the UCB terminal, check for loose wiring between the UCB and M2.

7. If 24 volts is not present at the UCB supply air blower motor terminal, check for 24 volts from the room thermostat. If 24 volts is not present from the room thermostat, check for the following:
  - a. Proper operation of the room thermostat (contact between R and G with the fan switch in the "ON" position and in the "AUTO" position during operation calls).
  - b. Proper wiring between the room thermostat and the UCB.
  - c. Loose wiring from the room thermostat to the UCB.
8. If 24 volts is present at the room thermostat but not at the UCB, check for proper wiring between the thermostat and the UCB, i.e. that the thermostat G terminal is connected to the G terminal of the UCB, and for loose wiring.
9. If the thermostat and UCB are properly wired, replace the UCB.
10. If the blower motor runs with the fan switch in the "ON" position but does not run shortly after the furnace has ignited when the fan switch is in the "AUTO" position, check the room thermostat for contact between R and G during "W1" calls.

On calls for heating, the supply air blower operates but the draft motor does not (the room thermostat fan switch is in the "AUTO" position).

1. The draft motor has inherent protection. If the motor shell is hot to the touch, wait for the internal overload to reset.
2. If the motor shell is cold with the room thermostat calling for heat, check if 24 volts is present at the room thermostat but not at the UCB, check for proper wiring between the thermostat and the UCB, i.e. that the thermostat "W1" terminal is connected to the "W1" terminal of the UCB, and for loose wiring.
3. The draft motor is a 230 volt draft motor on all models regardless of unit supply voltage. If the ICB is flashing a code other than the heartbeat, then troubleshoot the device indicated by the fault code. If not, then remove power to the unit for more than 20 seconds. If upon restoring the power to the unit the draft motor does not start with a call for heat, then verify that terminal "L1" of the ICB has a minimum of 120 volts to ground on 230 and 460 volt models or a minimum of 18 volts to ground on 575 volt models. If terminal "L1" does not have the minimum voltage, then check the wiring between the unit control box and the ICB on all models and on 460 volt models, the transformer in the gas heat compartment and its wiring. If terminal "L1" does have the minimum voltage, then check for the minimum voltage on terminal "IND" of the ICB on single stage models and terminal "IND HIGH" of the ICB on two stage models. If voltage is not present at the terminal, then verify wiring between the control box and the ICB. If all wiring is intact, then ICB is at fault. If voltage is present at the terminal on 230 and 460 volt models, then the draft

motor is at fault. On 575 volt models, if voltage is present at the terminal, then check the draft motor relay (DMR on single stage gas heat and DMR-2 on two stage gas heat) mounted above the ICB. First verify that the relay is pulled in by visual inspection. If not, then verify the minimum voltage is present between terminals "A" and "B" of the relay. If the minimum voltage is not present, then check the wiring. If it is present, then verify that a minimum of 150 volts is present at terminals "5" and "7" of the draft motor relay. If not present at terminal "7" of the draft motor relay, then troubleshoot the transformer in blower section and its wiring. If present at terminal "7" and not at terminal "5" of the draft motor relay, then the relay is at fault. If the minimum voltage is present at terminal 5 of the draft motor relay, then the draft motor is at fault.

The ignitor sparks at the pilot burner but the pilot does not ignite and a gas odor is detected at the draft motor outlet.

1. Adjust the pilot adjust screw on the gas valve as described in "PILOT CHECKOUT" on page 57.
2. Check the supply pressure as described in "POST START CHECK LIST" on page 56. Make adjustments as necessary.
3. Check the pilot orifice and pilot burner for obstruction as described in paragraph above. Clean as needed but the problem should not be the gas valve.

The pilot burner ignites but the ignitor continues to spark and the main burners do not ignite.

1. Make the same checks and adjustment as described in "PILOT CHECKOUT" on page 57.
2. Check the supply pressure as described in "POST START CHECK LIST" on page 56. Make adjustments as necessary.
3. Make sure that the pilot burner is not bent or damaged.
4. Make sure that the ground connections at the pilot burner, gas valve and ignition control are intact. Check the ignitor wire for good electrical connection. If all are intact, replace the ignition control.

The pilot burner lights and the spark stops but the main burners do not light.

1. Check electrical connections between the ignition control and the gas valve. If intact, check for 24 volts across terminals "MV" and "GROUND" terminals. If no voltage detected, replace ignition control. If voltage is present, replace gas valve.

Main burners light but exhibit erratic flame characteristics.

1. Adjust air shutters as described in "BURNER AIR SHUTTER ADJUSTMENT" on page 58.
2. Check the main burner orifices for obstruction and alignment. Removal procedure is described in BURNER INSTRUCTIONS on page 57. Clean or replace burner orifices and burners as needed.

## Unit Flash Codes

Various flash codes are utilized by the unit control board (UCB) and the ignition control board (ICB) to aid in troubleshooting. Flash codes are distinguished by the short on and off cycle used (approximately 200ms on and 200ms off). To show normal operation, the control boards flashes a 1 second on, 1 second off "heartbeat" during normal operation. This is to verify that the UCB and the ICB are functioning correctly. Do not confuse this with an error flash code. To prevent confusion, a 1-flash, flash code is not used.

Current alarms or active restrictions are flashed on the UCB LED.

- **LAST ERROR** - When this button is pressed and released one time within five seconds, it flashes the last five flash codes on the board's LED. The most recent alarm is shown first and the oldest alarm is shown last.

When pressed and released twice within a five second span, the fault history is cleared.

- **TEST RESET** - When this button is pressed and released one time within five seconds, any anti-short cycle delays (ASCD) is by-passed for one cycle.

When this button is pressed twice within five seconds, any active lockouts are reset.

- **COMM SET UP** - If the board is to be networked with other units, this button is used to set the network address. The first time the button is pressed within five seconds, it scans the bus, then assigns itself the first available address (starts at 2). It then flashes that address one time. Pressing the button two times within five seconds causes the control to flash its address.

Pressing the button three times within five seconds forces the control to reset its address to 1, which is the factory default.

## Fan On And Off Delays

The fan ON and OFF delays can be field adjusted by pressing a combination of buttons on the UCB.

- **Gas Heat Option #1** - Press the **LAST ERROR** and **TEST RESET** buttons simultaneously and then release. The control flashes three times as it writes a 30 second delay ON and a 90 second delay OFF to the program.
- **Gas Heat Option #2** - Press the **COMM SETUP** and **TEST RESET** buttons simultaneously and then release. The control flashes four times as it writes a 30 second delay ON and a 180 second delay OFF to the program.
- **Electric Heat** - Press and release the **COMM SETUP** and **LAST ERROR** buttons at the same time. The control flashes twice on the LED as the control writes a 0 second ON and a 30 second OFF fan delay to the control's program memory.

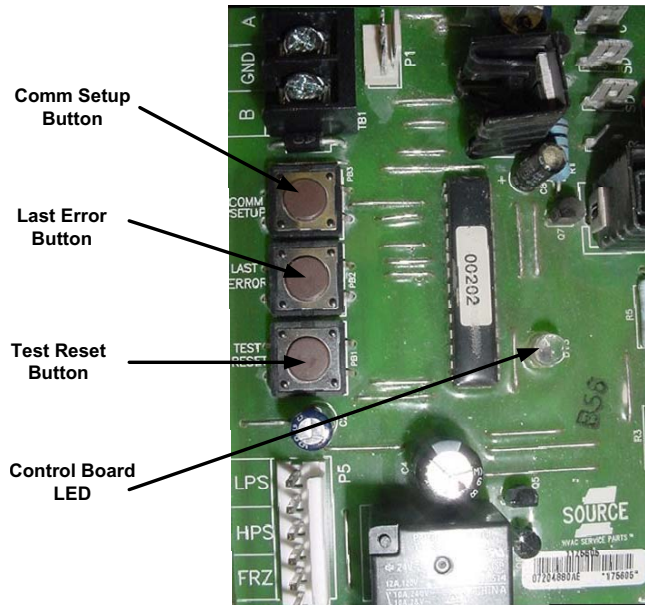

Figure 27: Unit Control Board

Table 29: Unit Control Board Flash Codes

Flash Code	Description
On Steady	Control Failure - Replace Control
Heart Beat	Normal Operation
1 Flash	Not Applicable
2 Flashes	Control waiting ASCD <sup>1</sup>
3 Flashes	HPS1 - Compressor Lock out
5 Flashes	LPS1 - Compressor Lock out
7 Flashes	FS1 - Compressor Lock out
9 Flashes	Ignition Control Locked Out/ Ignition Control Failure / Limit Switch Trip / No Jumper Plug in Heat Section
10 Flashes	Compressors Locked Out On Low Outdoor Air Temperature <sup>1</sup>
11 Flashes	Compressors Locked Out Because The Economizer Is Using Free Cooling <sup>1</sup>
13 Flashes	Compressor Held Off Due To Low Voltage <sup>1</sup>
14 Flashes	EEPROM Storage Failure (Control Failure)
OFF	No Power or Control Failure

1. These flash codes do not represent alarms.

Table 30: Ignition Control Board Flash Codes

Flash Code	Description
Heart Beat	Normal Operation
1 Flash	Not Applicable
2 Flashes	Pressure / Centrifugal Switch Open with Inducer On
3 Flashes	Pressure / Centrifugal Switch Closed with Inducer Off
4 Flashes	Not Applicable
5 Flashes	Lock Out From Too Many Flame Losses
6 Flashes	High Temperature Switch Open (Primary or Aux.)
7 Flashes	Rollout Switch Open
8 Flashes	Flame Present With Gas Off
9 Flashes	Gas Valve Stuck Off or On
10 Flashes	Flame Sense Circuit Failure