

Earthquake[®]

OPERATING & PARTS MANUAL

MC43E/MC43 Mini Cultivator

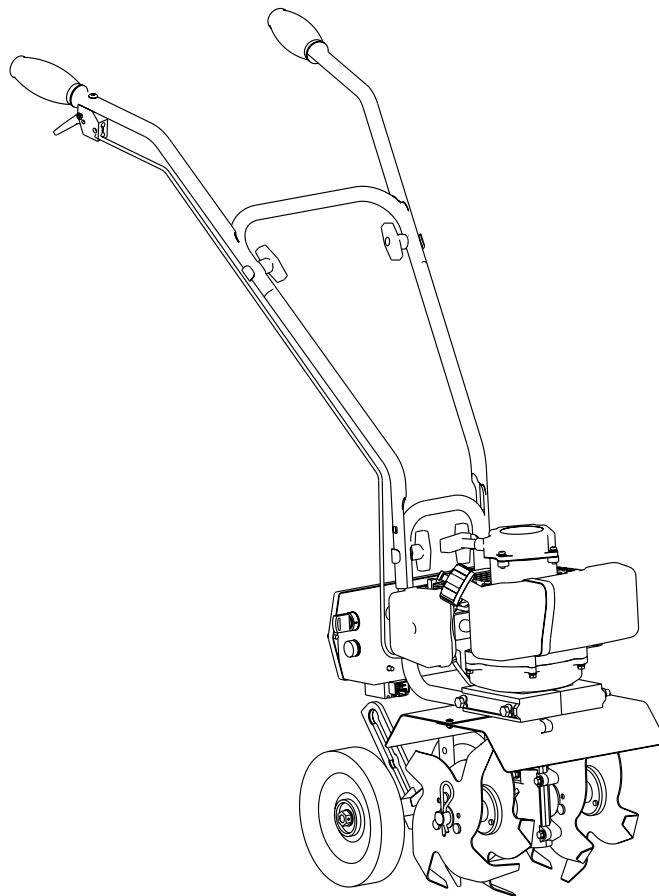

Ardisam, Inc.
1690 Elm Street, Cumberland, Wisconsin 54829
Phone (715)822-2415 • Fax (715)822-2223
1-800-345-6007

Email info@ardisam.com
www.ARDISAM.COM

OMMC43E/MC43 Rev. 1/20/06
©Copyright 2006 Ardisam, Inc.
All Rights Reserved. Printed in USA.

THANK YOU . . .

for purchasing an Earthquake® Mini Cultivator from Ardisam, Inc. We have worked to ensure that it meets high standards for usability and durability. With proper care, your cultivator will provide many years of service. Please take the time to read this manual carefully to learn how to correctly operate and maintain your cultivator. Congratulations on your investment in quality.

REGISTRATION

Fill out and mail the registration card located in your Owner's Manual packet. Warranty is valid only if your completed registration card is received by Ardisam, Inc., at time of purchase.

Model Number _____

Serial Number _____

Engine Serial Number _____

Date of Purchase _____

Place of Purchase _____

WARRANTY**One Year Limited Warranty**

The Ardisam, Inc., Manufacturing Company warrants this Earthquake® Mini Cultivator to be free from defects in material or workmanship. Conditions of this warranty include:

What is covered under warranty:

Ardisam, Inc. will repair or replace any part defective in workmanship or material within one year after delivery of the electric start mini cultivator to the original purchaser.

What is not covered under warranty:

This warranty applies only to products which have not been repaired or altered outside our factory. It covers only defects resulting from normal use, and does not cover defects arising from misuse, alteration, negligence, commercial use, or accident. This warranty applies only to the original purchaser, and is not transferrable.

How to obtain service:

Call 1-800-345-6007 for service assistance, or return the product to us at the address below with transportation charges prepaid.

This warranty supersedes all other warranties either expressed or implied and all other obligations or liabilities on our part. Ardisam, Inc., does not assume, and does not authorize any other person to assume for us, any liability in connection with the sale of our products. This guarantee is void unless warranty card is properly filled out and returned to Ardisam, Inc., Cumberland, Wisconsin, at time of purchase.



Ardisam, Inc.
 1690 Elm Street, Cumberland, WI 54829
 Phone (715) 822-2415 Main Fax (715) 822-2223
 1-800-345-6007
 Email info@ardisam.com
www.ARDISAM.COM

Owner's Responsibility

Accurate assembly and safe and effective use of the mini cultivator is the owner's responsibility.

- Read and follow all safety instructions.
- Carefully follow all assembly instructions.
- Maintain the mini cultivator according to directions and schedule included in this Earthquake Operator's Manual.
- Ensure that anyone who uses the mini cultivator is familiar with all controls and safety precautions.

Special Messages

Your manual contains special messages to bring attention to potential safety concerns, machine damage as well as helpful operating and servicing information. Please read all the information carefully to avoid injury and machine damage.



CAUTION

Avoid injury! This symbol and text highlight potential hazards or death to the operator or bystanders that may occur if the hazards or procedures are ignored.



Avoid damage! This text is used to tell the operator of actions or conditions that might result in damage to the machine.

NOTE: General information is given throughout the manual that may help the operator in the operation or service of the machine.



WARNING

CALIFORNIA PROPOSITION 65 WARNING

Engine exhaust from this product contains chemicals known to the State of California to cause cancer, birth defects, or other reproductive harm.

Important Safety Precautions

Please read this section carefully. Operate the mini cultivator according to the safety instructions and recommendations outlined here and inserted throughout the text. Anyone who uses this mini cultivator must read the instructions and be familiar with the controls.



This symbol points out important safety instructions which if not followed could endanger your personal safety. Read and follow all instructions in this manual before attempting to operate this equipment.

- Do not transport the mini cultivator from one place to another with the engine running.
- The tines of the cultivator should not rotate when the engine is idling. If it does rotate when engine is idling, contact Ardisam, Inc. for instructions.
- Dress appropriately when operating the cultivator. Always wear sturdy footwear. Never wear sandals, sneakers, or open shoes, and never operate the cultivator with bare feet. Do not wear loose clothing that might get caught in moving parts. Always wear safety glasses for eye protection.
- Always keep hands, feet, hair and loose clothing away from any moving parts on engine and cultivator.
- Do not allow children to operate this mini cultivator. Do not allow adults to operate the mini cultivator without proper instruction.
- Do not operate any power equipment under the influence of alcohol or drugs.
- Keep all screws, nuts and bolts tight.
- Engine should be turned off and cool, spark plug wire must be removed from spark plug before any repairs or adjustments are attempted.
- Temperature of muffler and nearby areas may exceed 150° F (65° C). Avoid these areas.
- Never run engine indoors or in an enclosed area. Engine exhaust contains carbon monoxide, an odorless and deadly gas.
- Carefully inspect the area to be cultivated, and remove all foreign objects. Do not cultivate above underground utilities, including water lines, gas lines, electric cables, or pipes. Do not operate the mini cultivator in soil with large rocks and foreign objects which can damage the equipment.
- If an object becomes lodged in the tines, turn engine off, remove the wire from the spark plug and secure, allow to cool before attempting to remove the foreign object.
- Use only original equipment parts from Ardisam, Inc. including all nuts and bolts.

Engine Safety Precautions

Warning Carbon Monoxide Poisoning

All engines contain carbon monoxide in their exhaust. Carbon monoxide is a deadly, colorless, tasteless, odorless gas which may be present even if you do not smell or see any engine exhaust. Levels of carbon monoxide, which can be deadly, can be present for days in an enclosed area that has poor ventilation. Any level of carbon monoxide, if inhaled, can cause headaches, drowsiness, nausea, dizziness, confusion and eventually death. If you experience any of these symptoms, seek fresh air and **medical attention immediately.**

Preventing Carbon Monoxide Poisoning

- Never run engine indoors.
- Never try to ventilate engine exhaust indoors. Carbon monoxide can reach dangerous levels very quickly.
- Never run engine outdoors where exhaust fumes may be pulled into a building.
- Never run engine outdoors in a poorly ventilated area where the exhaust fumes may be trapped and not easily taken away. (Examples include: in a large hole or areas where hills surround your working area.)
- Never run engine in an enclosed or partially enclosed area. (Examples include: buildings that are enclosed on one or more sides, under tents, car ports or basements.)
- Always run the engine with the exhaust and muffler pointed in the direction away from the operator.
- Never point the exhaust muffler towards anyone. People should always be many feet away from the operation of the engine and its attachments.

Gasoline Fires and Handling Fuel Safely

Fuel and fuel vapors are highly flammable. Never use fuel where a spark or flame may be present. Never use fuel where a potential source of ignition could occur. (Examples include: hot water or space heaters, clothes dryer, electric motors, etc.) Keep flames and sparks away from engine and fuel to prevent fires. Fuel fires spread very quickly and are highly explosive.

Prevention of Gasoline Fires

- Never fill your fuel tank with fuel indoors. (Examples include: basement, garage, barn, shed, house, porch, etc.)
- Always fill fuel tank outside in a well ventilated area.
- Never remove the fuel cap or add fuel with the engine running. Stop engine and allow to cool before filling.
- Never drain fuel from engine in an enclosed area.
- Always wipe up excess (spilled) fuel from engine before starting. Clean up spilled fuel immediately.

- Allow spilled fuel to dry, after wiping and before starting.
- Allow fuel fumes/vapors to escape from the area before starting engine.
- Test the fuel cap for proper installation before starting and using engine.
- Always run the engine with fuel cap properly installed on the engine.
- Always unscrew gas cap vent screw while engine is running.
- Never smoke while refilling engine fuel tank.
- Prevent fire and explosion caused by static electric discharge. Use only nonmetal, portable fuel containers approved by the Underwriter's Laboratory (U.L.) or the American Society for Testing & Materials (ASTM).
- Do not store engine with fuel in fuel tank indoors. Fuel and fuel vapors are highly explosive.
- During storage, screw down gas cap vent screw tightly.
- Never pour fuel from engine fuel tank.
- Never siphon fuel by mouth to drain fuel tank.
- Always have an adult fill the fuel tank.
- Never allow an adult or anyone under the influence of drugs or alcohol to fill engine.
- Never allow children to fill the engine.
- The clutch will transfer maximum power after about two hours of normal operation. During this break-in period clutch slippage may occur. The clutch should be kept free of oil or other moisture for efficient operation.

Burns and Fires

The muffler, muffler guard and other parts of the engine become extremely hot during the operation of the engine. These parts remain extremely hot after the engine has stopped.

Prevention of Burns and Fires

- Never remove the muffler guard from the engine.
- Never touch the muffler guard because it is extremely hot and will cause severe burns.
- Never touch parts of the engine that become hot after operation.
- Always keep materials and debris away from muffler guard and other hot parts of the engine to avoid fires.

This engine is designed to operate using a catalytic converter which contributes to the engine's compliance with the EPA.

! CAUTION

Avoid injury! Hot gases are a normal by-product of a functioning catalytic converter. Follow all safety instructions to prevent burns and fires.

Steps for Working on Engine or Mini Cultivator

! CAUTION

Do Not Alter/Modify Engine or Mini Cultivator: Avoid injury! Never alter or modify the engine from the factory. Serious injury or death may occur if engine is modified or altered.

! CAUTION

Avoid injury! When working on or replacing parts for the engine or mini cultivator you must always disconnect spark plug wire from the spark plug and keep it away from the spark plug.

1. Turn off engine switch.
2. Disconnect the spark plug wire from the spark plug.
3. Securely place the disconnected spark plug wire away from the spark plug and any metal parts. This must always be done or arcing may occur between spark plug wire and metal parts.
4. Replace or repair the part on the engine or mini cultivator.
5. Check all parts that were repaired, or removed during repair, that they are secure and fit correctly.

NOTE: All repair parts must come from the factory. Never replace parts that are not specifically designed for the engine or mini cultivator.

6. Replace spark plug wire.

SAFETY DECAL

This mini cultivator has been designed and manufactured to provide you with the safety and reliability you would expect from an industry leader in outdoor power equipment manufacturing.

Reading this manual and the safety instructions it contains will provide you with the necessary basic knowledge to operated this equipment safely and effectively. We have placed a safety decal on the cultivator to remind you of some of this important information while you are operating the unit.

This important safety decal is illustrated below, and is shown here to help familiarize you with the location and content of the safety messages you will see as you perform normal cultivating operations. Please review this decal now, and if you have any questions regarding its meaning or how to comply with these instructions, reread the complete safety instruction text in this manual, or contact your local dealer.

Should this decal become unreadable because of being worn, faded, or otherwise damaged during the use of your mini cultivator, please use the part number information provided to order a replacement label from your local authorized dealer. These decals are easily applied, and will act as a constant visual reminder to you, and others who may use the equipment, to follow the safety instructions necessary for safe, effective operation of your mini cultivator.



**Part No. LBLMC43W
Warning Decal MC43E
Tine Shield Decal**

UNPACK MINI CULTIVATOR

1. Carefully lift the mini cultivator out of the box, remove any packing material and cut any ties holding the handlebar pieces to the mini cultivator assembly.

ASSEMBLY

1. Stand the mini cultivator assembly upright with tines and wheels on a level surface. Wheels should be set in the lowest position. **DO NOT place the mini cultivator on a high surface where it can fall and cause property damage or personal injury.**

2. Using two tee handle nuts (4640), two bolts (4642), and two curved washers (4641), assemble the middle handlebar (4693) to the lower handlebar (4695) that is already attached to the mini cultivator assembly. See Figure 1. The middle handlebar can be installed in two positions one high and one low. **DO NOT overtighten the tee handle nuts.**

3. Attach the upper right and left handlebars (4689 & 4690) to the middle handlebar using the two remaining tee handle nuts, bolts, and curved washers. See Figure 1. **DO NOT overtighten the tee handle nuts.**

For the Electric Start Mini Cultivator Model MC43E, remove the battery box cover and plug the white plastic connector from the battery into the mating white plastic connector in the battery box. See Figure 2. **Make sure the ignition key is removed from the ignition before connecting the wiring for the battery.**

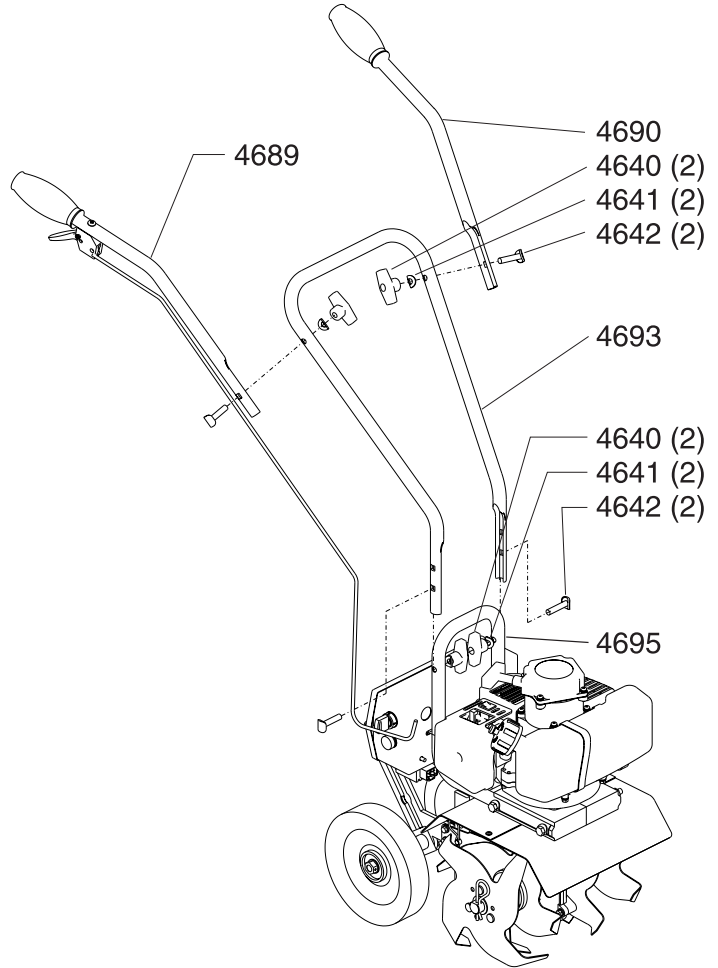

Figure 1
(Model MC43E shown. Figure 1 applies to both models MC43 & MC43E.)



Figure 2

CHARGING THE BATTERY (MODEL MC43E ONLY)

To charge the battery, check that the battery wiring is properly connected and plug the battery charger (4681) into the side of the battery box (4656) with matching three-prong plug. Plug the other end of the battery charger into a standard 120V outlet receptacle.

Battery should reach full charge after 2 hours of continuous charging.

NOTE: RECHARGEABLE BATTERIES HAVE A LIMITED NUMBER OF CHARGE CYCLES AND MAY EVENTUALLY NEED TO BE REPLACED. BATTERY LIFE AND NUMBER OF CHARGE CYCLES VARY BY USE.

**WARNING**

Avoid electrical shock! DO NOT use battery charger around water or in wet conditions.

IMPORTANT

DO NOT spray water on or near the electronics of the mini cultivator as this may result in damage to the electrical components.

IMPORTANT

DO NOT try to start engine while the battery charger is connected. This could damage the engine and battery.

Earthquake[®] OPERATION

Preparing Engine for Starting

GAS AND OIL

Quality

To operate the engine you must use a high quality 2-cycle oil to ensure that the engine operates correctly throughout the life of the engine. Use unleaded regular, unleaded premium or reformulated automotive fuels only. It may contain up to 10% ethanol, 10% gasohol, 15% MTBE, and 15% ETBE. **DO NOT use Methanol or leaded fuels.**

Mixture

Run mini cultivator with a 50:1 ratio. **DO NOT use marine 2-cycle oil.** See chart 1.

CHART 1

<u>GAS</u>	<u>OIL</u>	<u>RATIO</u>
1 gallon	2.5 ounces	50:1
2 gallons	5 ounces	50:1
5 gallons	13 ounces	50:1

Mixing Fuel and Filling Fuel Tank

CAUTION

Avoid injury! Never store engine with fuel in the tank indoors. Fuel and fuel vapors are highly flammable.

CAUTION

Avoid injury! Never mix fuel and oil directly in engine fuel tank. Use only nonmetal, portable fuel containers approved by the Underwriter's Laboratory (U.L.) or the American Society for Testing & Materials (ASTM).

CAUTION

Avoid injury! An adult must always handle and fill the engine with fuel.

Mixing Fuel

1. Fuel must be mixed in a container outside in a well ventilated area.
2. Fill certified fuel container 1/4 full of recommended fuel.
3. Add recommended amount of 2-cycle oil. **DO NOT use 2-cycle marine oil.**
4. Screw container cap on straight and tight.
5. Shake the container to mix fuel and oil.
6. Unscrew cap slowly to vent. Add the remainder of fuel requirements.

1-800-345-6007

7. Wipe away any spilled fuel or oil and allow to evaporate before moving or transporting.

CAUTION

Avoid injury! Always handle gas in a well ventilated area, outdoors, away from flames or sparks.

IMPORTANT

This engine uses a gas/oil mixture. DO NOT run on straight gas only, engine damage will result.

Filling Fuel Tank

1. Shut-off engine and allow engine to completely cool before refilling the fuel tank.
2. Move to a well ventilated area, outdoors, away from flames and sparks.
3. Clean debris from area around the fuel cap.
4. Loosen fuel cap slowly. Place the cap on a clean, dry surface.
5. Carefully add fuel without spilling.
6. Do not fill gas tank completely full, allow space for fuel to expand.
7. Immediately replace fuel cap and tighten. Wipe off spilled fuel and allow to dry before starting engine.

CAUTION

Avoid injury! DO NOT start engine if fuel is spilled. Wipe off excess fuel and allow to dry. Remove engine from area to avoid sparks.

Starting and Stopping Engine

IMPORTANT

DO NOT start engine with battery charger connected to battery. This could cause damage to the mini cultivator.

1. Move engine to a well ventilated area, outdoors, to prevent carbon monoxide poisoning.
2. Move to an area away from flames or sparks, to avoid ignition of vapors if present.
3. Remove all debris from air cleaner holes and fuel cap to ensure proper air flow.
4. Turn switch to the **ON** position.

Earthquake OPERATION

5. Priming:

- When using the primer bulb, allow the bulb to return completely to its original position between pushes.
- Choke must be in the **OFF or RUN** position when pushing or using the primer bulb.

First Start: Starting new engine for first time or after running out of gas, prime 3 times.

Cold Start: Starting engine after it has been sitting or stored briefly with fuel in the tank, prime 1 time above 55° Fahrenheit or 2 times below 55° Fahrenheit.

Warm Start: Do not use primer or full choke if engine did not run out of gas or has not cooled completely. Flooding of engine will occur.

6. Choke:

- **Full choke** position is defined by moving the choke lever as far to the **ON or CHOKE** position as possible. **Half choke** is defined when the choke lever is between **ON or CHOKE and OFF or RUN**.

Warm Start: No choke or half choke is needed.



CAUTION

Avoid injury! Starter rope can cause an unanticipated jerk towards engine. Please follow instructions to avoid injury.

7. **For Manual Start** - Grasp starter handle and pull out slowly, until it pulls slightly harder. Without letting it retract, pull rope with a rapid full arm stroke. Let it return to its original position very slowly. Repeat this step everytime the starter rope is pulled.

8. Pull recoil until engine fires or runs.

NOTE: If engine fails to start after 5-6 pulls, push primer 1 time and pull starter rope again.

9. After engine starts running, move choke lever to **HALF CHOKE**.

For Electric Start

10. Check that the battery is connected using the white plastic connectors inside the battery box. Insert ignition key into ignition and turn key to the “**start**” position until engine starts running, then release key to the “**on**” position. **DO NOT hold the ignition key in the “start” position longer than 3 seconds.**

11. Run engine for 30 to 45 seconds at half choke position until engine warms up.

12. Move choke lever to **OFF** position and move throttle to desired speed.

13. To stop, turn switch to **OFF** position on manual start models. On electric start, turn ignition key to the **OFF** position.

1-800-345-6007



CAUTION

Avoid injury! If engine fails to start after the above operations, please contact Ardisam, Inc. at 1-800-345-6007.

DO NOT attempt to start engine in the following ways:

- **DO NOT use starting fluid.**
- **DO NOT spray flammable liquids or vapors into air cleaner, carburetor or spark plug chamber.**
- **DO NOT remove spark plug and attempt to start engine. Flammable fuel can spray out & ignite from a spark from spark plug.**



CAUTION

Avoid injury! Never leave engine running while unattended. Turn off after every use.



CAUTION

Avoid injury! Never carry mini cultivator from one location to another while engine is running.

Normal Operation

1. The clutch will transfer maximum power after about two hours of normal operation. During this break-in period clutch slippage may occur. The clutch should be kept free of oil and other moisture for efficient operation.
2. Cultivate without placing excessive body weight on the unit. The mini cultivator operates most efficiently with the weight of the unit itself.
3. Never run engine indoors. Exhaust fumes are deadly.

Using the Screw Type, Manual Venting Gas Cap

Your mini cultivator is equipped with a screw type, manual venting gas cap.

1. Before starting the engine, turn the screw in the top of the gas cap 2-3 turns (counterclockwise) to its venting position. **DO NOT turn the screw to the point that it stops (4-5 turns counterclockwise).** To ensure that gas will not spill during use, check that the gas cap is screwed on tightly and the gas cap screw is in the venting position.
2. After using the mini cultivator and before putting away or transporting it in a vehicle, screw the gas cap screw and gas cap on (clockwise) tightly. This will prevent gas from leaking during storage. The gas cap will not leak during storage if gas cap is tight and the screw at the top is tight.

**CAUTION****To prevent accidental starting:**

Avoid injury! Engine must be turned off and cool, and spark plug wire must be removed from spark plug before checking and adjusting engine or equipment.

**CAUTION**

Avoid injury! Temperature of muffler and nearby areas may exceed 150° F (65° C). Avoid these areas.

**CAUTION**

Avoid injury! Check mini cultivator often for loose nuts and bolts. Keep these items tightened.

Mini Cultivator Maintenance

1. The transmission case has 1.5 oz. or (3 tbsp.) of grease installed at the factory. It is recommended that once a year the transmission case be split and the grease level checked. A high quality lithium grease is recommended, which can be purchased at most automotive and hardware stores. **DO NOT overfill.**
2. Keep all screws, nuts, and bolts tight.
3. For cold weather operation, store the unit in a cool environment. Transferring the unit from a warm to a cold place can cause the build up of harmful condensation.

Engine Maintenance**CAUTION**

Avoid injury! Never store engine with fuel in the tank inside a building. Potential sparks may be present for ignition of fuel and fuel vapors.

**CAUTION**

Avoid injury! An adult must always do maintenance and repair on engine and mini cultivator.

**CAUTION**

Avoid injury! Engine must be shut-off, cool, and spark plug wire removed before any repair or maintenance can be done.

Cooling Fins

- Cooling fins, air inlets and linkages must be free from any debris before each use.

Air Filters

- Never run engine without air cleaner properly installed. Added wear and engine failure may occur if air cleaner is not installed on engine.
- Service air cleaner every 3 months of operation. **Clean and oil filter daily in extremely dusty conditions.**

Steps for Cleaning Air Filters

Never twist air filters when cleaning. Always press.

1. Wash in warm water with mild soap until dirt and debris are removed. Press filter when washing, do not twist.
2. Rinse in warm water until soap and dirt are removed.
3. Dry filter by wrapping in a clean cloth and pressing filter until it is dry.
4. Apply oil to the entire filter.
5. Remove excess oil by squeezing filter.
6. Attach the filter and filter cover to the engine.

Spark Plug

- Check spark plug at the beginning of each season.
1. Remove dirt and debris around the spark plug before removing.
 2. Remove spark plug and replace if any of the following have occurred: pitted electrodes, burned electrodes, cracked porcelain, or deposits around the electrodes.
 3. Check spark plug for proper gap (.025" to .030").
 4. After analysis of the spark plug, install original or a new spark plug and tighten securely.

NOTE: DO NOT OVERTIGHTEN!

NOTE: SPARK PLUG IS NGK BM6A OR CHAMPION CJ8.

Carburetor

- Never tamper with factory setting of the carburetor.

Tine Removal and Installation

To Remove Tines

1. Remove the cotter pins from each end of the tine shaft.
2. Slide the four tines off the shaft.

To Install Tines

1. First slide the inside tines onto each end of the tine shaft. One inside tine is stamped with a "B" and the other is stamped with a "C".
2. Slide the outside tine "A" and tine "D" onto each end of the shaft next. The tines should be installed in the correct order so that they are positioned left to right A, B, C, D, as viewed from the user's position on the mini cultivator. Make sure that the hub collars on both the right and left pairs of tines face each other so that there is adequate spacing between the tine blades. See Figure 3.
3. Insert the cotter pins into the holes at each end of the tine shaft to lock the tines into place.

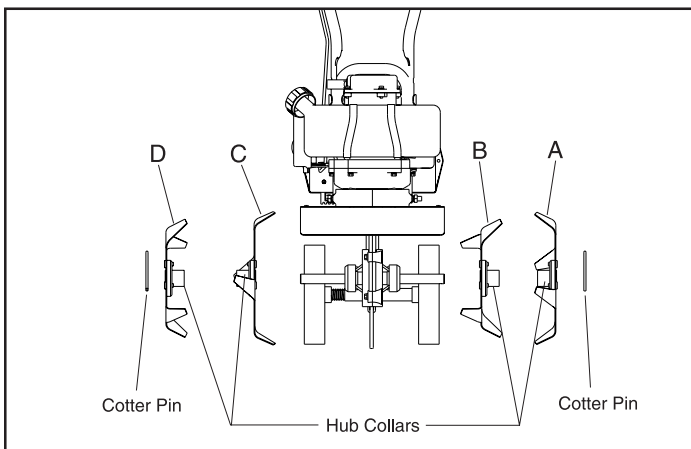

Figure 3 (Frontal View)

Adjusting Wheels and Drag Stake

The wheels on the mini cultivator can be adjusted to one of three positions. The lowest wheel position is used for transporting the mini cultivator across a smooth level surface while the engine is not running. The two higher positions are used when cultivating in soil and help stabilize the unit when cultivating at different depths. See Figure 6.

To adjust wheels up or down, see Figures 4 and 5.

1. Pull the locking metal sleeve against the spring until it releases from one of the three holes in the vertical guide.
2. Slide the wheel set up or down to the desired position, and release the locking metal sleeve until it locks into one of the three holes in the vertical guide.

The drag stake is used to help regulate cultivating depth and control the mini cultivator from leaping forward during operation. Resistance to forward motion is greatest when the drag stake is set in its lowest position allowing for deeper cultivation.

To adjust the drag stake, see Figure 4.

1. Pull the pin out of the drag stake mount hole.
2. Position the drag stake so the pointed tip is directed downward.
3. Insert the pin into the hole that achieves desired depth.

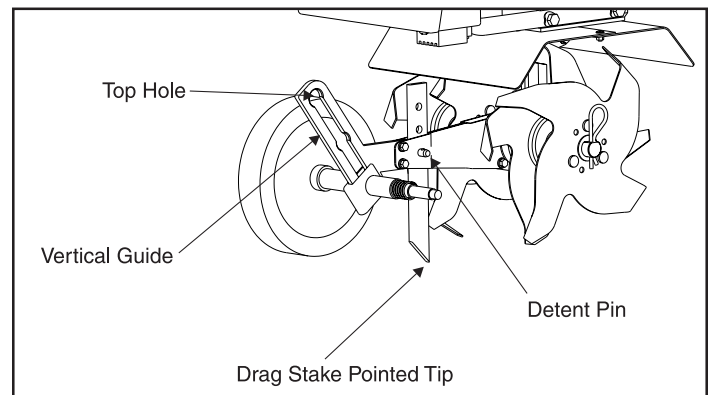

Figure 4

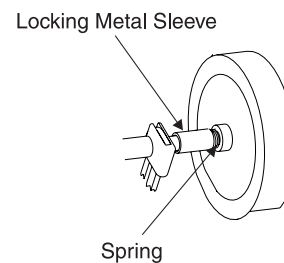

Figure 5

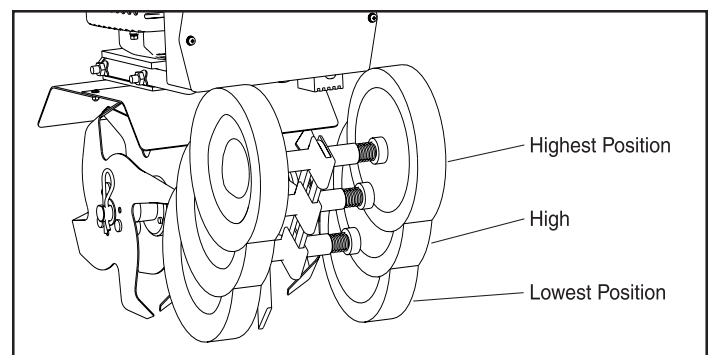

Figure 6

Transporting Your Mini Cultivator

1. Never transport engine inside an enclosed space or vehicle. Fuel or fuel vapors may ignite causing serious injury or death.
2. If fuel is present in the fuel tank, transport in an open vehicle in an upright position.
3. If an enclosed vehicle must be used, remove gas into an approved red gasoline container. **DO NOT siphon by mouth.**
4. Run engine to use up the fuel in the carburetor and fuel tank. Always run engine in a well ventilated area.
5. Wipe away any spilled fuel from engine and mini cultivator. Allow to dry.
6. Gas cap and gas cap vent screw should be turned down tightly before transporting mini cultivator in a vehicle.

Long Term Storage

- If your mini cultivator will not be used for more than one month, prepare it for long term storage.

Steps for Long Term Storage

1. Add fuel stabilizer according to manufacturer's instructions.
2. Run engine for 10-15 minutes to ensure that the stabilizer reaches the carburetor.
3. Remove the remainder of the fuel from the gas tank into an approved fuel container.



CAUTION

Avoid injury! To avoid injury or death, never siphon fuel by mouth.



CAUTION

Avoid injury! Never store mini cultivator with fuel in the fuel tank inside an enclosed area or building.

4. Store mini cultivator in a upright position.
5. Remove all debris from cultivator tines and engine.

SERVICE INFORMATION



IN CASE OF A SERVICE PROBLEM, DO NOT SEND UNIT BACK TO RETAILER. CONTACT ARDISAM, INC. AT 1-800-345-6007. WE WELCOME YOUR CALL.

In the event that you experience trouble operating your mini cultivator, begin by following the suggestions in the troubleshooting guide in this section.

The guide will help you pinpoint the causes of common problems and identify remedies.

For more complicated repairs, you may want to rely on your retailer, an authorized mechanic or Ardisam, Inc. (contact your retailer for a list of authorized mechanics in your area). A parts catalog is included in this section.

We will always be glad to answer any questions you have, or help you find suitable assistance. To order parts or inquire about warranty, call or write us at the address found in the next column under the section ordering repair parts, or check out our website - www.ardisam.com.

TROUBLESHOOTING

Problem	Possible cause	Remedy/Action
Engine will not start	<ol style="list-style-type: none"> 1. Power switch off 2. Spark plug wire disconnected 3. Battery not connected or low charge 	<ol style="list-style-type: none"> 1. Flip switch to ON position 2. Connect spark plug wire to spark plug 3. Connect or charge battery
Engine runs rough, floods during operation	<ol style="list-style-type: none"> 1. Dirty air cleaner 2. Choke partially engaged 3. Carburetor out of adjustment 	<ol style="list-style-type: none"> 1. Clean or replace air cleaner 2. Turn off choke 3. Call factory
Engine is hard to start	<ol style="list-style-type: none"> 1. Stale fuel 2. Spark plug wire loose 3. Dirty carburetor 	<ol style="list-style-type: none"> 1. Drain old fuel and replace with fresh. Use gas stabilizer at end of season 2. Make sure spark wire is securely attached to spark plug 3. Clean carburetor, use gas stabilizer, new gas can
Engine misses or lacks power	<ol style="list-style-type: none"> 1. Clogged fuel tank 2. Clogged air cleaner 3. Improper carburetor adjustment 4. Spark plug dirty, improper gap, or wrong type 	<ol style="list-style-type: none"> 1. Remove and clean 2. Clean or replace 3. Call factory 4. Replace spark plug and adjust gap
Tines turn at idle	<ol style="list-style-type: none"> 1. Idle speed too high 2. Broken clutch spring 	<ol style="list-style-type: none"> 1. Adjust idle speed lower 2. Replace spring
Engine runs, then quits	<ol style="list-style-type: none"> 1. Gas cap not venting 	<ol style="list-style-type: none"> 1. Make sure gas cap vent screw is in venting position
Engine revs too high	<ol style="list-style-type: none"> 1. Low fuel in tank 	<ol style="list-style-type: none"> 1. Add fuel to tank

ORDERING REPAIR PARTS

Parts can be obtained from the store where your mini cultivator was purchased or direct from the factory. To order from the factory, call or write to:

Ardisam, Inc.

1690 Elm Street, Cumberland, WI 54829
Phone (715) 822-2415 Main Fax (715) 822-2223
1-800-345-6007

Email info@ardisam.com

www.ARDISAM.com

Please include the following information with your order:

1. Part numbers
2. Part description
3. Quantity
4. Model number and serial number



CAUTION

Practice safety at all times. Engine must be turned off and allowed to cool, and spark plug wire must be disconnected before attempting any maintenance or repair.

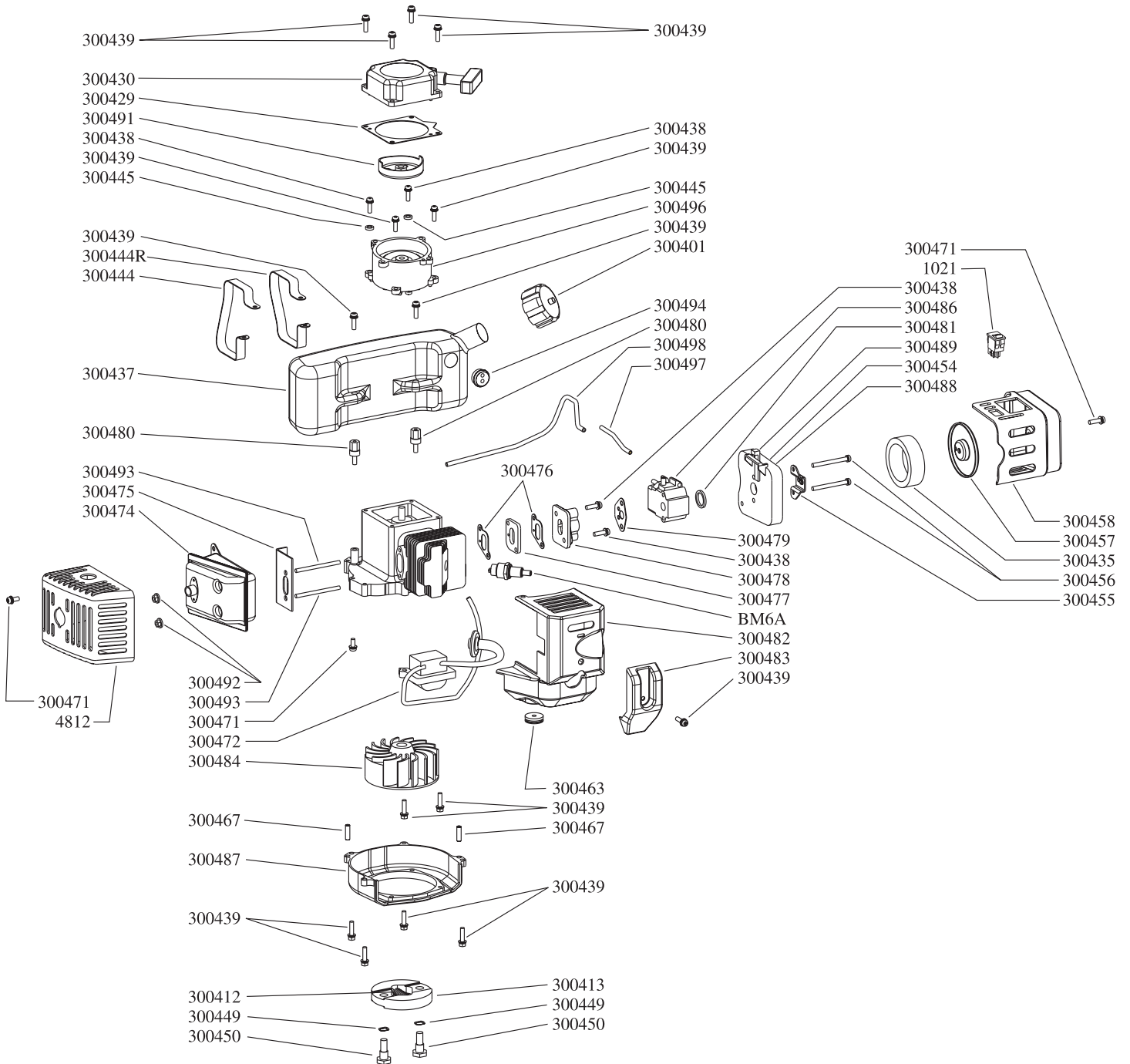

MINIMUM ORDER \$10.00

<u>Part #</u>	<u>Description</u>	<u>Qty.</u>	<u>Part #</u>	<u>Description</u>	<u>Qty.</u>
4812	MUFFLER COVER, METAL	1	300472	IGNITION COIL	1
300401	FUEL TANK CAP, MANUAL VENTING	1	300474	CATALYTIC CONVERTER MUFFLER	1
300412	CLUTCH SPRING	1	300475	MUFFLER GASKET	1
300413	CLUTCH ROTOR ASSEMBLY	1	300476	INTAKE GASKET	2
300429	RECOIL PLATE	1	300477	HEAT DISK	1
300430	RECOIL ASSEMBLY	1	300478	INTAKE WINDPIPE	1
300435	AIR FILTER	1	300479	CARBURETOR GASKET	1
300437	FUEL TANK	1	300480	FUEL TANK THREADED SPACER	2
300438	BOLT W/WASHER, M5 X 25MM	4	300481	O-RING	1
300439	BOLT W/WASHER, M5 X 18MM	15	300482	ENGINE SHROUD	1
300444	FUEL TANK SUPPORT, LEFT SIDE	1	300483	ENGINE SHROUD COVER	1
300444R	FUEL TANK SUPPORT, RIGHT SIDE	1	300484	MAGNETO FLYWHEEL	1
300445	WASHER, M5	2	300486	CARBURETOR	1
300449	SPRING WASHER	2	300487	ENGINE MOUNTING COVER	1
300450	SHOULDER BOLT	2	300488	CHOKE	1
300454	INTAKE COVER	1	300489	CHOKE LEVER	1
300455	INTAKE COVER ADAPTER PLATE	1	300491	RECOIL CLUTCH	1
300456	BOLT, M5 X 50MM	2	300492	NUT, M6	2
300457	AIR FILTER COVER	1	300493	STUD BOLT, M6 X 62MM	2
300458	INTAKE COVER	1	300494	FUEL TANK GROMMET, DOUBLE HOLE	1
300463	ENGINE SHROUD GROMMET	1	300496	STARTER MOTOR	1
300467	LOCATING PIN	2	300497	PRIMER LINE CUT TO 4"	1
300470	FUEL LINE HOSE & FILTER	1	300498	FUEL LINE CUT TO 9"	1
300471	BOLT, M5 X 12MM	3	BM6A	SPARK PLUG	1

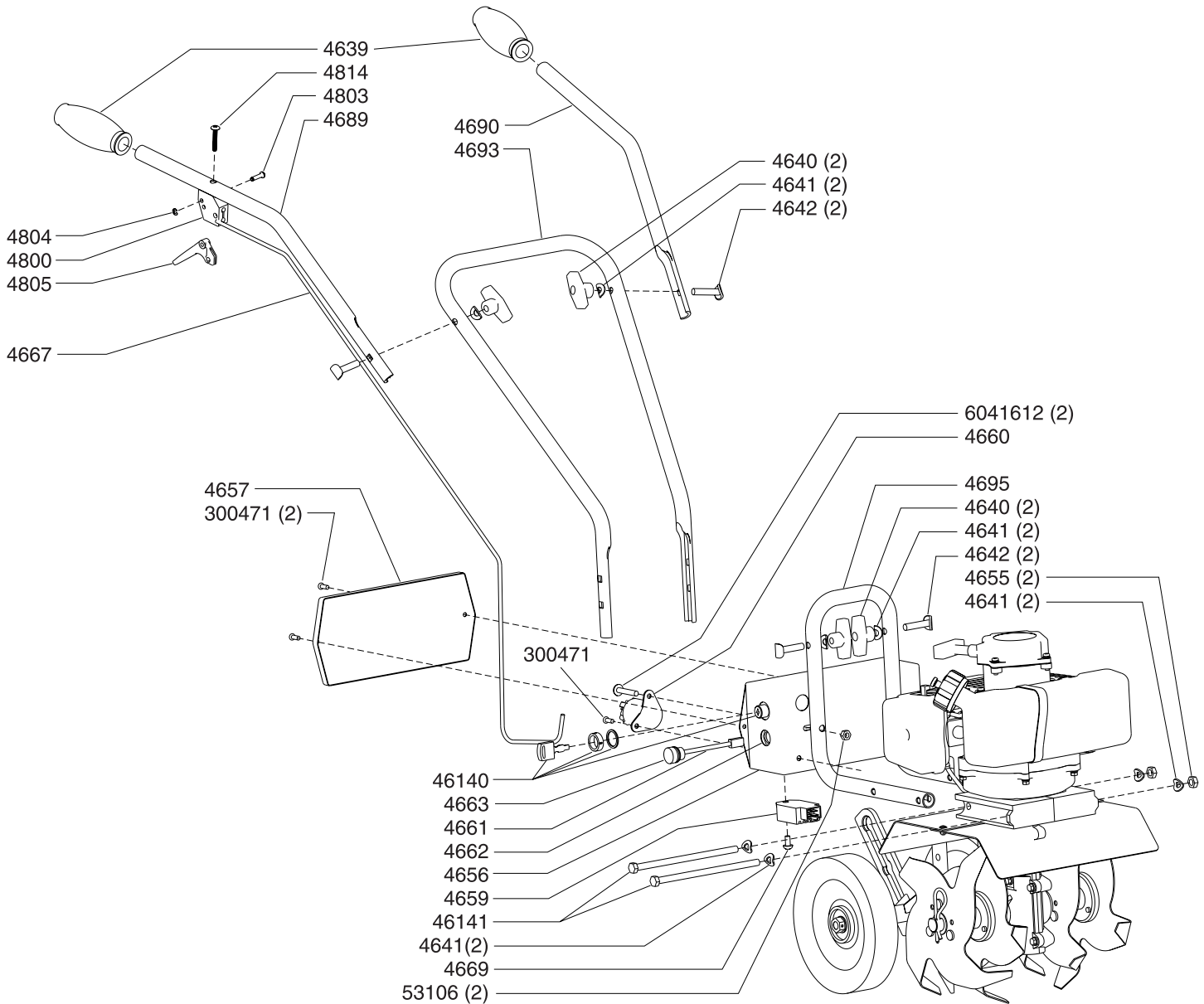

Part #	Description	Qty.	Part #	Description	Qty.
300471	BOLT, M5 X 12MM MC43E	3	4662	NUT, CHARGER PIGTAIL MC43E	1
46122	BATTERY 12V 7A MC43E	1	4663	CAP, CHARGER PIGTAIL MC43E	1
46140	KEY SWITCH MC43E	1	4667	THROTTLE CABLE	1
46141	BOLT M8 X 1.25 X 160MM HEX HD	2	4669	BOLT, M6 X 1MM X 12MM PAN HD MC43E	1
4639	HANDLE GRIP	2	4681	BATTERY CHARGER, (NOT SHOWN) MC43E	1
4640	NUT, T-HANDLE	4	4689	HANDLEBAR UPPER RIGHT	1
4641	WASHER	8	4690	HANDLEBAR UPPER LEFT	1
4642	BOLT, HANDLE CLAMP	4	4693	HANDLEBAR MIDDLE	1
4643	ENGINE & TRANSMISSION ASSEMBLY	1	4695	HANDLEBAR LOWER	1
4650	NUT, M6 FLANGED HEX HD	2	4800	THROTTLE HOUSING	1
4655	NUT, M8 HEX HD	2	4803	CLEVIS PIN, .188 DIA. GROOVED	1
4656	BATTERY BOX MC43E	1	4804	E- CLIP, RETAINING RING FOR .188 PIN	1
4657	COVER, BATTERY BOX MC43E	1	4805	THROTTLE TRIGGER, LONG THROW	1
4659	VOLTAGE RECTIFIER MC43E	1	4814	BOLT, 10-24 X 1-1/4" PHILLIPS TRUSS HD	1
4660	SOLENOID MC43E	1	53106	NUT, 1/4-20 BI-WAY LOCK MC43E	2
4661	CHARGER PIGTAIL MC43E	1	6041612	SCREW, 1/4-20 X 1-1/2" PH TRUSS HD MC43E	2

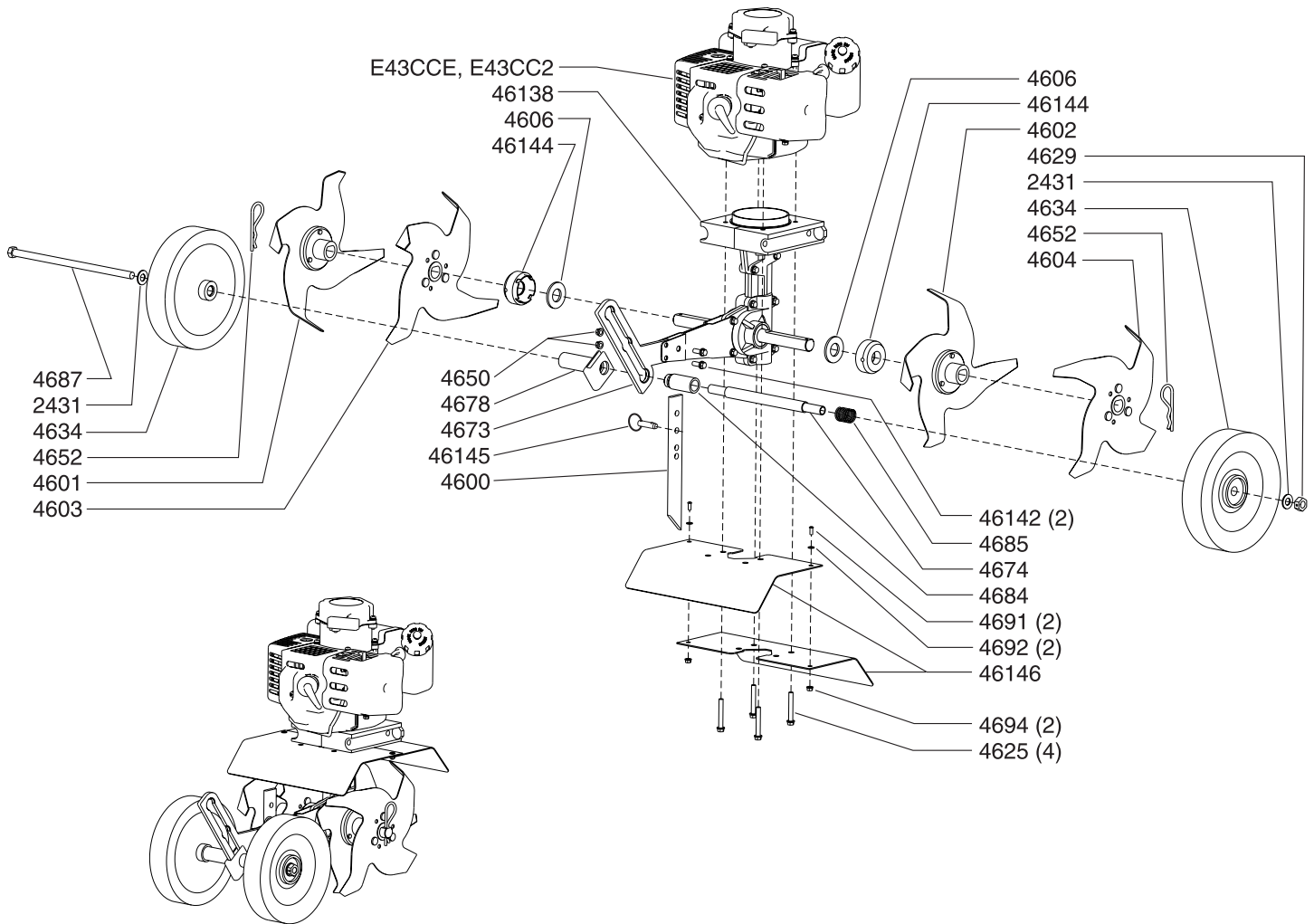

Part #	Description	Qty.	Part #	Description	Qty.
2431	WASHER, 10MM NARROW FLAT	2	4650	NUT M6 X 1.0 FLANGED HEX HD	2
4600	DRAG BAR	1	4652	HAIR PIN, 5/8-3/4 COTTER	2
4601	TINE "A" RIGHT OUTSIDE	1	4673	WHEEL HOLDER	1
4602	TINE "C" LEFT INSIDE	1	4674	WHEEL TUBE	1
4603	TINE "B" RIGHT INSIDE	1	4678	GUIDE, WHEEL TUBE	1
4604	TINE "D" LEFT OUTSIDE	1	4684	TUBE, WHEEL LOCK	1
4606	WASHER, FIBER	2	4685	SPRING, WHEEL LOCK	1
46138	TRANSMISSION ASSEMBLY	1	4687	BOLT M10 X 1.5 X 225MM HEX HD	1
46142	BOLT M6 X 1.0 X 15MM FLANGED HEX HD	2	4691	BOLT, M4 X 0.7 X 10MM PHILLIPS PAN HD	2
46144	DUST CAP	2	4692	WASHER, M4 FLAT	2
46145	DETENT PIN 5/16 X 1-1/2"	1	4694	NUT M4 X 0.7 FLANGED HEX HD	2
46146	TINE SHIELD	2	E43CC	ENGINE 43CC CAT CONVERT (MC43)	1
4625	BOLT, M6 X 1.0 X 42MM FLANGED HEX HD	4	E43CCE	ENGINE 43CC CAT CONVERT ELEC START	1
4634	WHEEL	2			

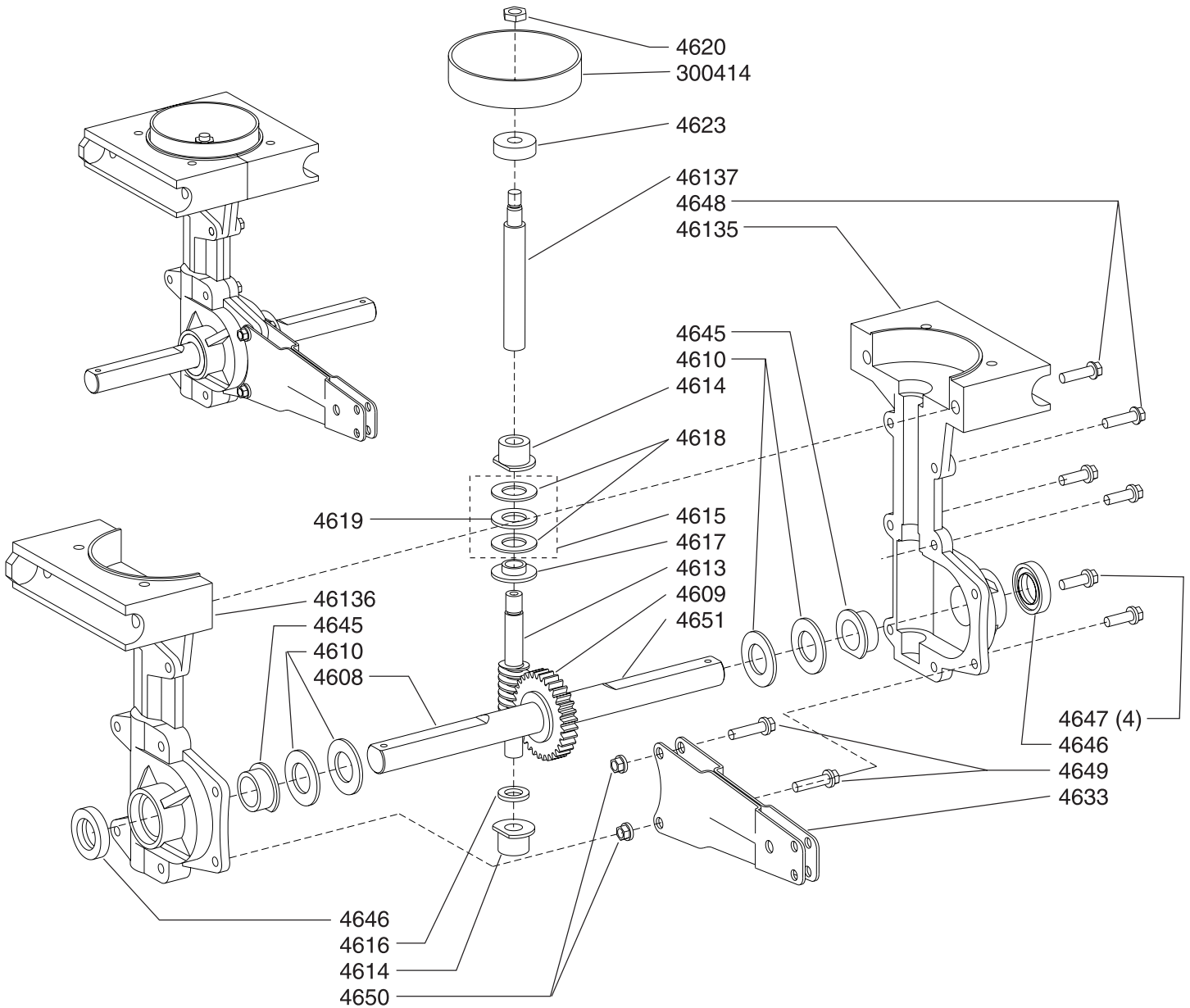

Part #	Description	Qty.	Part #	Description	Qty.
300414	CLUTCH DRUM	1	4618	WASHER, THRUST	2
4608	TINE SHAFT	1	4619	THRUST BEARING CAGE ASSEMBLY	1
4609	GEAR, TINE SHAFT	1	4620	NUT, M8 JAM	1
4610	SHIM, TINE SHAFT	4	4623	BALL BEARING, 9MM	1
4613	WORM SPUD	1	4633	ARM WHEEL/DRAG STAKE MOUNT	1
46135	CASTING, RIGHT LOWER TRANSMISSION	1	4645	BUSHING, TINE SHAFT	2
46136	CASTING, LEFT LOWER TRANSMISSION	1	4646	SEAL, TINE SHAFT	2
46137	DRIVE SHAFT	1	4647	BOLT, M6 X 1.0 X 18MM FLANGED HEX HD	4
4614	BUSHING, DRIVE SHAFT	2	4648	BOLT, M6 X 1.0 X 22MM FLANGED HEX HD	2
4615	THRUST BEARING ASSEMBLY	1	4649	BOLT, M6 X 1.0 X 24MM FLANGED HEX HD	2
4616	SPACER, BUSHING	1	4650	NUT, M6 FLANGED HEX HD	2
4617	REDUCER, THRUST BEARING	1	4651	TINE GEAR & SHAFT ASSEMBLY	1

The Border-Edger Kit is a useful tool for making clean cuts in the lawn along the borders of gardens, flower beds, walkways, and driveways for a well manicured look.

1. Remove the cultivating tines.
2. Slide the border-edger attachment onto either side of the tine shaft. Make sure the hub collar of the edger tine faces outward from the mini cultivator.
3. Slide one of the spacers onto the tine shaft next to the edger tine and insert the cotter pin through the hole at the end of the tine shaft.
4. Slide the wheel onto the opposite side of the tine shaft.
5. Slide the remaining spacer onto the tine shaft next to the wheel and insert the remaining cotter pin through the hole at the end of the tine shaft.

Before using the Border-Edger Kit, the drag stake should be removed from the mini cultivator and the wheels should be set to the highest (top) position.

CAUTION

Be aware that the mini cultivator could unexpectedly bounce upward, or jump forward if the tines strike concrete, pavement, or other hard surfaces or hard obstacles buried under ground.

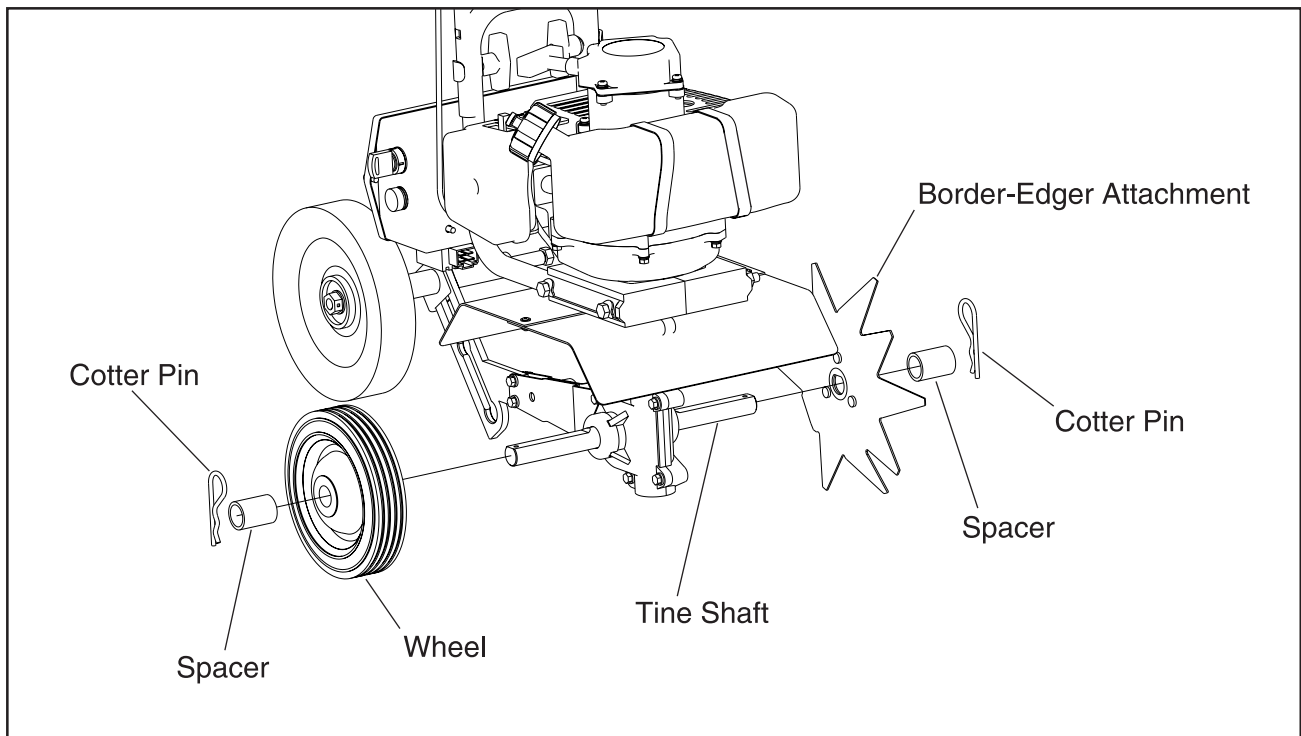

**EK43 Border-Edger Attachment Kit
(fits both Models MC43 & MC43E)**

Earthquake[®]

Ardisam, Inc.

1690 Elm Street, Cumberland, Wisconsin 54829

Phone (715)822-2415 • Main Fax (715)822-2223

1-800-345-6007

Email info@ardisam.com

www.ARDISAM.com