

# VOX

Valvetronix

# ToneLab LE

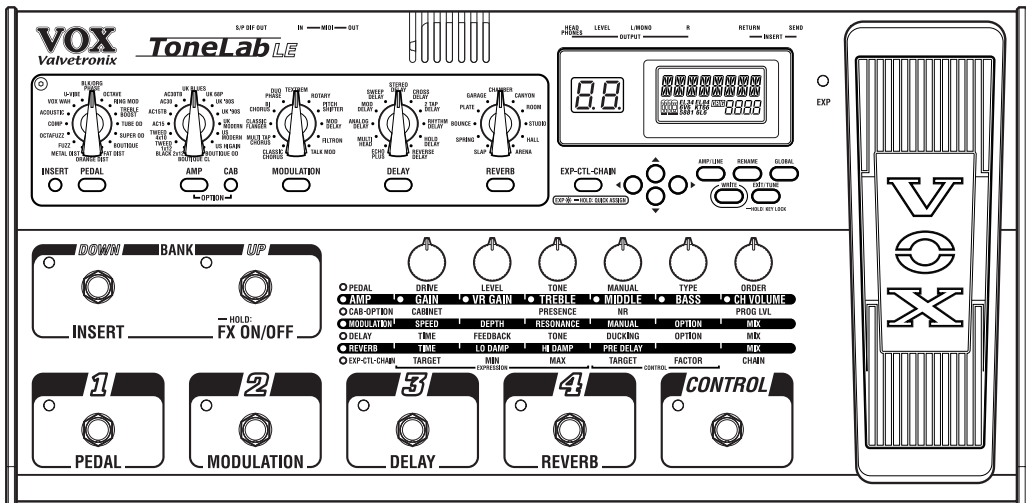

## Owner's Manual

---

## Precautions

### Location

Using the unit in the following locations can result in a malfunction.

- In direct sunlight
- Locations of extreme temperature or humidity
- Excessively dusty or dirty locations
- Locations of excessive vibration
- Close to magnetic fields

### Power supply

Please connect the designated AC/AC power supply to an AC outlet of the correct voltage. Do not connect it to an AC outlet of voltage other than that for which your unit is intended.

### Interference with other electrical devices

Radios and televisions nearby may experience reception interference. Operate this unit at a suitable distance from radios and televisions.

### Handling

To avoid breakage, do not apply excessive force to the switches or controls.

### Care

If the exterior becomes dirty, wipe it with a clean, dry cloth. Do not use liquid cleaners such as benzene or thinner, cleaning compounds or flammable polishes.

### Keep this manual

After reading this manual, please keep it for later reference.

### Keeping foreign matter out of your equipment

Never set any container with liquid on this equipment. If liquid gets into the equipment, it could cause a breakdown, fire, or electrical shock.

Be careful not to let metal objects get into the equipment. If something does slip into the equipment, unplug the AC/AC power supply from the wall outlet. Then contact your nearest Korg dealer or the store where the equipment was purchased.

#### **THE FCC REGULATION WARNING (for U.S.A.)**

This equipment has been tested and found to comply with the limits for a Class B digital device, pursuant to Part 15 of the FCC Rules. These limits are designed to provide reasonable protection against harmful interference in a residential installation. This equipment generates, uses, and can radiate radio frequency energy and, if not installed and used in accordance with the instructions, may cause harmful interference to radio communications. However, there is no guarantee that interference will not occur in a particular installation. If this equipment does cause harmful interference to radio or television reception, which can be determined by turning the equipment off and on, the user is encouraged to try to correct the interference by one or more of the following measures:

- Reorient or relocate the receiving antenna.
- Increase the separation between the equipment and receiver.
- Connect the equipment into an outlet on a circuit different from that to which the receiver is connected.
- Consult the dealer or an experienced radio/TV technician for help.

Unauthorized changes or modification to this system can void the user's authority to operate this equipment.

---

### **CE mark for European Harmonized Standards**

CE mark which is attached to our company's products of AC mains operated apparatus until December 31, 1996 means it conforms to EMC Directive (89/336/EEC) and CE mark Directive (93/68/EEC). And, CE mark which is attached after January 1, 1997 means it conforms to EMC Directive (89/336/EEC), CE mark Directive (93/68/EEC) and Low Voltage Directive (73/23/EEC).

Also, CE mark which is attached to our company's products of Battery operated apparatus means it conforms to EMC Directive (89/336/EEC) and CE mark Directive (93/68/EEC).

## **Data Handling**

Incorrect operation or malfunction may cause the contents of memory to be lost, so we recommend that you save important data on a floppy disk or other media source. Please be aware that Korg will accept no responsibility for any damages which may result from loss of data.

\* Company names, product names, and names of formats etc. are the trademarks or registered trademarks of their respective owners.

---

# Table of Contents

<b>Quick Start</b> .....	<b>6</b>
Setup .....	6
Listen to the Programs .....	7
Switching effects on/off.....	7
Create your own Sounds .....	7
<b>Introduction</b> .....	<b>9</b>
Main Features.....	9
Valve Reactor Technology .....	10
An overview of ToneLab LE .....	11
Signal Route .....	11
Modes.....	11
Amp and effect settings (Edit) .....	11
Realtime expression pedal and control switch .....	11
Saving a program .....	11
MIDI and output destination settings .....	11
<b>A Guitarist’s Guided Panel Tour</b> .....	<b>12</b>
The Top Panel.....	12
1 Model select section.....	12
2 Edit section.....	14
3 Display section.....	14
4 Setting/Global section .....	15
5 Bank/Program/Select section.....	16
6 Effect control section.....	17
Rear panel.....	18
7 Rear panel section .....	18
<b>Setup</b> .....	<b>19</b>
Basic connections.....	19
Using the S/P DIF connector .....	20
Adjust the digital output level.....	20
Using ToneLab LE with a MIDI device or computer .....	20
Output settings .....	21
<b>Playing ToneLab LE</b> .....	<b>22</b>
Program Select mode.....	22
Selecting a program .....	22
Effect On/Off mode.....	22
Switching effects on/off.....	22
Activating or deactivating the Key Lock function .....	23
Activating the Key Lock function.....	23
Deactivating the Key Lock function .....	23
<b>Creating and Storing your own Programs</b> .....	<b>24</b>
Creating your own Program.....	24
Tweaking an Existing Program.....	24

---

Create Your Own Program .....	24
Changing the connection order of the Effects (CHAIN) .....	25
Using the Three-band Equalizer .....	25
Naming a Program .....	26
Storing a Program .....	26
Restoring a setting to its original value .....	26
<b>Explanations of the Amp, Cabinet and Effect Types.....</b>	<b>27</b>
A. AMP Models .....	27
B. CABINET Models .....	31
What goes with what? .....	32
C. PEDAL Effects .....	34
D. Modulation (Mod) Effects .....	37
E. DELAY Effects .....	41
F. REVERB Effects.....	44
<b>Tuner (Bypass, Mute).....</b>	<b>46</b>
Tuning procedure .....	46
Calibrating the Tuner .....	46
<b>Using the expression pedals.....</b>	<b>47</b>
Expression pedal settings.....	47
Expression Target Quick Assign .....	47
Setting the Expression Target .....	47
Expression pedal control initialization settings (EXPINIT) .....	48
Control switch settings.....	49
Switching each effect on/off.....	49
Using TAP TEMPO to set a parameter .....	49
Effect control.....	49
FACTOR value knob 5 setting .....	49
Adjusting the Sensitivity of the Pedal .....	50
Expression pedal .....	50
<b>Control via MIDI .....</b>	<b>51</b>
Connecting a MIDI Device or Computer .....	51
Setting the MIDI Message .....	51
Setting the MIDI Channel (GLOBAL "MIDI CH").....	51
Program Change (GLOBAL "PCHG OUT") .....	51
Control Change (GLOBAL "CCHG I/O") .....	52
Parameter Change (GLOBAL "SYEX OUT") .....	52
Backing up and Restoring Program Data (GLOBAL "DUMP CUR," DUMP ALL") .....	53
Backing Up .....	53
Restoring .....	53
<b>Restoring the Factory Preset Programs.....</b>	<b>54</b>
<b>Troubleshooting .....</b>	<b>54</b>
<b>Specifications.....</b>	<b>55</b>
MIDI Implementation Chart.....	56

---

---

# Quick Start

## A GUIDE FOR THOSE WHO WANT TO PLAY GUITAR FIRST, AND READ THE MANUAL LATER!

**Y**ep, we know. You'd rather be playing guitar than reading this manual. Who wouldn't? I know I would so here's a "Quick Start" to get you up and running without delay (pun intended)

First we'll get started by trying out ToneLab LEs programs and then we'll explain how to use the various controls and knobs to create your own sounds.

Right. Once you've gotten the urge to play out of your system, you should really give this manual a chance — it's been written by a fellow guitar fanatic and is full of useful tips and info that'll give you much more detail about ToneLab LE than what's in the "Quick Start."

Okay, okay, we're almost done here. I just want to recommend that you refer to the illustrations of the top and rear panels and display in "A Guitarist's Guided Panel Tour" (p.12) so you can see the pictures while we talk and you tweak. Now let's plug in and play!!!

### SETUP

1. If you're connecting ToneLab LE to a mixer or recorder, connect OUTPUT jacks L/MONO and R (7.6) to the input jacks of your mixer or recorder. If you're listening through headphones, connect your headphones to the HEADPHONES jack (7.8).  
If you're connecting ToneLab LE to a guitar amp(s) connect OUTPUT jacks L/MONO and R to the input jacks of your guitar amp(s).  
**NOTE:** If you're connecting ToneLab LE to something that only has a mono input, just use the L/MONO jack.
2. Turn the LEVEL knob (7.7) on the rear panel of ToneLab LE all the way to the left (as viewed from the rear), setting the volume to 0.
3. Plug the supplied AC/AC power supply into ToneLab LE's rear panel AC9V power inlet (7.3), and plug the power supply into an AC wall socket.
4. Plug your guitar into the rear panel INPUT jack (7.4).
5. Before you turn ToneLab LE on, lower the volume of your amp or mixer so you don't hear any potentially speaker-damaging pops or buzzes. Then turn on the STANDBY switch (7.2) to power up ToneLab LE.
6. If you connected ToneLab LE to a mixer or recorder, press the AMP/LINE button to select the AMP/LINE menu, and use the value knob 1 to select "Ln1, 2" (LINE). If you've connected ToneLab LE to your guitar amp, set this to "AP1-3" (AMP) setting.  
**HINT:** If you've connected ToneLab LE to your guitar amp, select the setting that is best for your amp. (p.21)  
**HINT:** If you selected "Ln2" (LINE), you can use a three-band EQ to adjust the tone that would best suit your output settings. (p.25)
7. Turn up the volume controls on your amp or mixer, and use ToneLab LE's rear panel LEVEL knob to adjust the volume.  
**NOTE:** You won't hear sound for several seconds while the valve (a.k.a. "vacuum tube" if you live on the west side of the Atlantic) warms up. This isn't a malfunction — it's a real analogue valve!

---

## LISTEN TO THE PROGRAMS

8. Use the BANK UP, DOWN switches (5.1) to select a bank 1–30. Notice that the number in the bank display (3.4) blinks and changes.  
**HINT:** ToneLab LE has 120 programs, organized into 30 banks with four programs in each bank (30 x 4 = 120). When shipped from the factory, banks 1–10 contain 40 programs. (The programs in banks 1–10, 11–20 and 21–30 are identical to each other) Program Select mode lets you select these programs. There's also an effect ON/OFF mode that lets you turn individual effects on/off.
9. Use the program select 1–4 switches (5.2) to select a program. The program LED you selected will light, and the number in the bank display will also change and stay lit. Go ahead and play your guitar.  
For example if you want to select program 3-1 (bank 3, program 1), press the BANK UP or DOWN switch to make the bank display read "3," and then press the program select 1 switch to make the LED light.  
If you're selecting a program in the same bank, simply press a program select 1–4 switch. If you want to select a program from a different bank, you'll need to perform steps 8 and 9 in that order.  
**NOTE:** If you can't select a program, you're probably not in Program Select mode. Get back into Program Select mode as described in "Program Select mode" (p.22).  
**HINT:** The preset programs cover an amazing range of sounds; fat hi-gain lead sounds, nostalgic clean sounds that work best with your rhythm (neck) pickup, aggressive modern crunch sounds for heavy riffing with your lead (bridge) pickup, and much more.
10. The expression pedals are assigned to control the most appropriate parameters for each program, such as wah, volume, delay, reverb input level, or other effect parameter. The CONTROL switch is assigned functions such as TAP tempo input of the delay time.
11. Press and hold down the BANK UP switch for one second to turn on the switch's green LED and to enter Effect On/Off mode. Effect On/Off mode lets you turn each effect on or off just as if you were using a set of stomp boxes. Program select 1–4 will turn the pedal, modulation, delay, and reverb on or off respectively, and the BANK DOWN switch will bypass the insert effect.

## SWITCHING EFFECTS ON/OFF

12. The model select buttons will be lit (ON) or dark (OFF) to indicate the on/off state of each effect. If you press a button that is dark or turn the model selector, the effect will turn on and the model select button will blink. If you press a button that is blinking, the effect will turn off and the button will go dark.

## CREATE YOUR OWN SOUNDS

13. To adjust the sound of the AMP model, use the AMP selector to select one of the sixteen amp models. Then you can simply adjust the sound pretty much in the same way as if you were really using the actual model of guitar amp you selected.  
Adjust the GAIN value knob 1, TREBLE value knob 3, MIDDLE value knob 4, BASS value knob 5, and the VR GAIN value knob 2 (which corresponds to the MASTER) as you like. To get the most accurate vintage tube amp distortion, raise the VR GAIN as high as possible. The CH VOLUME value knob 6 lets you adjust the volume while retaining the overall sound including the distortion produced by the Valve Reactor.  
If you press the CAB button while holding down the AMP button, you can then use value knob 3 to adjust the PRESENCE, value knob 4 to adjust the NR (Noise Reduction) effect, and value knob 6 to adjust the volume level of the programs (PROG LVL).  
Pressing the CAB button, then turning the value knob 1 lets you select a cabinet model. When you use the AMP MODEL and CABINET MODEL selectors, a different type of guitar amp will appear before your very eyes — or, should we say, ears!  
**HINT:** P.32 lists recommended combinations of amp and cabinet models but others are fine too.

---

**HINT:** If you want to replicate the sound of the original amp, set [VR GAIN] to the maximum setting on vintage-type models that do not have a master volume control (i.e., AC15, AC15TB, AC30, AC30TB, UK BLUES, UK 68P, BLACK 2x12, TWEED 1x12, and TWEED 4x10). For modern-type amps that have a master volume control, adjust [VR GAIN] in the same way that you would on the original amp. When the [VR GAIN] setting is low, preamp-type distortion will occur. As you raise the [VR GAIN] setting, the pre-amp will begin loading the Valve Reactor to cause clipping, and the warmth and distortion of the Valve Reactor will be added.

14. ToneLab LE provides a PEDAL effect that is placed before the amp, and MODULATION, DELAY, and REVERB effects that are placed after the cabinet.

For example if you want to use the PEDAL effect TREBLE BOOST, turn the PEDAL selector to select TREBLE BOOST. The PEDAL parameter LED of the edit section will blink, indicating the parameter line (the region listing the parameter names). Also, the LEDs below the value knobs will light, indicating the location of the knobs that you can use to control TREBLE BOOST. Now turn value knobs 1, 2, and 3 to adjust DRIVE, LEVEL, and TONE respectively. You can edit other effects using the same procedure.

**HINT:** Some effect settings may cause unwanted distortion (if there is such a thing!!). If this happens, lower the PROG LVL. (p.25)



---

# Introduction

## WELCOME ABOARD!

**M**any thanks for adding the **VOX Valvetronix ToneLab LE** to your sonic arsenal. We're sure it'll give you countless hours of great guitar tones that will *feel* as good as they sound!

To maximize your chances of enjoying a long and happy relationship with your ToneLab LE, please read this manual at least once, and (as they say), "use the product as directed." Keep the manual for future reference after you've read it; you'll want to re-read it later at some point to pick up cool tips you may have missed the first time around.

## MAIN FEATURES

- ToneLab LE features Valve Reactor technology that switches between Class A and Class AB power amp circuits with an actual 12AX7 (ECC 83) miniature triode valve (vacuum tube) to create the sound of an actual tube power amp, delivering the response and tone of classic amps.
- ToneLab LE uses sophisticated modeling technology to create classic amp, cabinet, and effect sounds. You can choose from sixteen amp types that include classic vintage amps and expensive high-end valve amps, and eleven different cabinet types. By combining amp types and cabinet types you can create an amazing range of sounds, many of which have never been heard before.
- Since high-quality effects are built in, ToneLab LE is all you need to create a completely finished sound. Sixteen types of pedal effects are placed before the amp, and after the cabinet are eleven types of modulation, eleven types of delay, and eleven types of reverb. You can choose one type for each effect, and use these four effects simultaneously plus Noise Reduction.
- You can store all of your own amp settings and effect model settings as a "program" in one of 120 program memories. ToneLab LE comes with 40 preset programs for instant gratification.
- For convenient tuning, an Auto Chromatic Tuner is built-in.
- There is expression pedal that you can use as a wah pedal, volume pedal, or to control a variety of effect parameters — a great feature for live performance.
- There's a Quick Assign function that makes it easy to assign parameters to the expression pedal.
- ToneLab LE provides control switches that let you do things like set the delay time via TAP TEMPO, switch insert effects on/off, or switch the speed of a rotary speaker ... again, must-have features for live performance.
- You can use the effect insert jacks to connect an external effect processor or stompbox.
- Featuring an S/P DIF optical digital output and MIDI IN and OUT connectors, ToneLab LE offers you plenty of potential and numerous options to expand your system.
- ToneLab LE Sound Editor is an editor/librarian software that lets you visually edit ToneLab LE's numerous parameters, and save and manage programs.

To obtain the "ToneLab LE Sound Editor," please contact the VOX distributor in your country or download the latest version from:

"<http://www.voxamps.co.uk>" or "<http://www.valvetronix.com/>"

To find your local Distributor go to:

"<http://www.voxamps.co.uk/dealers/worldwid.htm>"

---

# VALVE REACTOR TECHNOLOGY

## THE POWER (AMP) AND THE GLORY!

**V**alve Reactor technology was first used on the critically acclaimed VOX AD60/120VT Valvetronix amps.

The Valve Reactor circuitry in ToneLab LE however has been tuned-up especially for live performance.

Since conventional modeling effects for line recording are not used directly with a speaker, they do not include a power amp circuit, output transformer, or speaker. In other words, they only have a preamp circuit.

A real valve amp sound, however, is produced not just by the preamp, but also by the tone and distortion of the power amp, and by the constant changes in impedance that are created by the power amp driving the speakers. ToneLab LE contains an actual low-wattage valve power amp circuit, a virtual output transformer that uses solid-state components to simulate an output transformer, and a dummy speaker circuit that simulates the varying impedance of a real speaker. This means that although it's low-power, ToneLab LE has the same circuit structure of an actual all-valve amp.

While much of the tone creation and shaping carried out is done in the digital domain, its *Valve Reactor* power amp is 100% analogue. The resulting journey your guitar's signal takes through the analogue world of the power stage plays a major role in providing the all-important feel and tone of the original amps we modelled.

The *Valve Reactor* power stage is, to all intents and purposes, a bona fide valve (tube) push-pull power amplifier, but in miniature. It utilizes a 12AX7 (ECC83) valve (a dual triode device — meaning “two valves in one”) and is equipped with an output transformer, like a “real” valve amp.

The power amp output of ToneLab LE's Valve Reactor is designed to “read” the constantly changing impedance curve of the dummy speaker circuit system and feed this information back to the virtual output transformer — just like real valve amplifiers do. This information permits the behavior of the valve stage of the amp to vary with the speaker load (impedance), which is another important part of “real world” valve tone.

Apart from the vital valve tone this ingenious power amp design provides, it also allows us to replicate various “circuit characteristics” that are unique to the all-valve power stages of the amps we've modelled. These “characteristics” include: Class A or Class AB operation, Presence and Resonance (low end) control circuitry (both found in the negative feedback circuit that some, but not all, valve power amps have). Being able to match such vital characteristics helps ensure that each and every one of our models is as tonally authentic as possible — as opposed to the usual “close but definitely no cigar” norm of digital modeling. And just so you know, this patented in USA power amp technology is unique to VOX Valvetronix.

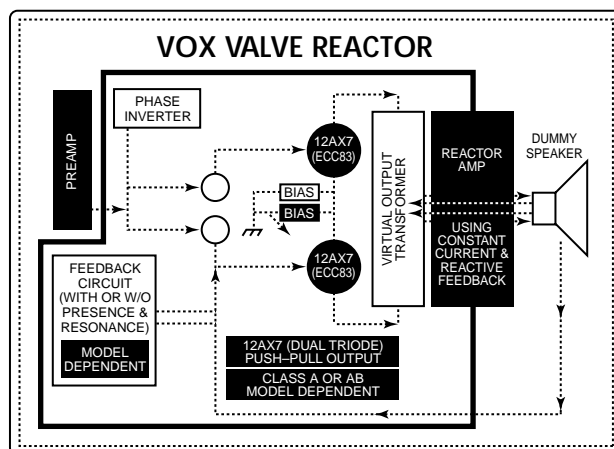

# AN OVERVIEW OF TONELAB LE

Let's talk about how ToneLab LE is structured.

## SIGNAL ROUTE

When you plug into ToneLab LE the signal passes through the following stages.

You might want to glance at the explanations in "A Guitarist's Guided Panel Tour" (p.12) while you read this section.

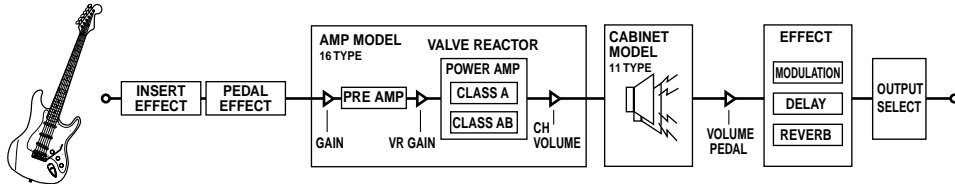

## MODES

ToneLab LE has a Program Select mode (where you can switch programs) and an Effect On/Off mode (where you can switch individual effects on/off). To switch between these modes, simply press the BANKUP (FX ON/OFF) switch which can be done even while you are performing.

## AMP AND EFFECT SETTINGS (EDIT)

The five model selectors, six value knobs, and various buttons let you edit the amp and effect settings directly and intuitively. You can use the CHAIN function to change the order in which the modulation, delay, and reverb effects are connected. Use the EXP-CTL-CHAIN button to set the CHAIN function.

## REALTIME EXPRESSION PEDAL AND CONTROL SWITCH

You can use the expression pedal and control switch to control wah, volume, or effect parameters with your feet. Use the EXP-CTL-CHAIN button to select the parameters you wish to control.

## SAVING A PROGRAM

By using the WRITE button, all settings you make can be saved as a "program." When doing so, you should use the RENAME button to give the program a new name. Once you've saved a program, you can use the program select switches to recall it instantly (in Program Select mode).

## MIDI AND OUTPUT DESTINATION SETTINGS

The GLOBAL button lets you make MIDI-related settings and specify the operation of the pedal for Program Change. The settings you make here are automatically saved within ToneLab LE so there's no need to perform the WRITE operation.

# A Guitarist's Guided Panel Tour

Here we're going to learn about the buttons and other controls on ToneLab LE's top and rear panel.

## THE TOP PANEL

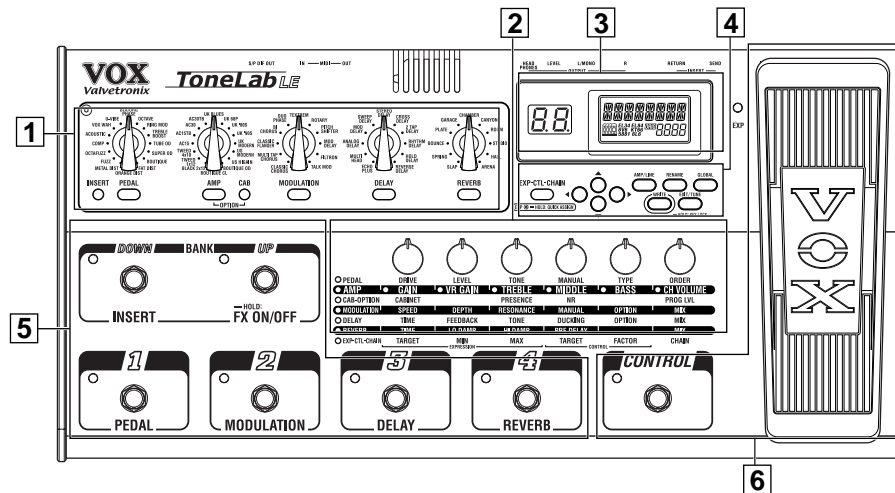

### 1 MODEL SELECT SECTION

Here you can select the model of amp, cabinet and effect models.

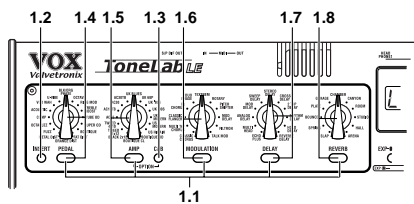

#### 1.1 MODEL select buttons

Use these when selecting the effect category you want to edit with value knobs 1–6, and when switching effects on/off. If an effect you're using is ON it will be lit (or blinking during editing), and if OFF it will be dark.

Press a button once and its LED will blink; now you can use value knobs 1–6 to edit the parameters of that effect.

If you want to turn off an effect that is currently on, press the model select button for the appropriate effect once (it blinks), and then press that model select button once again to turn it off (dark); the name display will indicate [--OFF--].

The pedal effect is placed in front of the amp model and the modulation, delay, and reverb are placed after the cabinet model.

**NOTE:** The reason that modulation, delay, and reverb effects are placed after the amp — rather than before it as a “stompbox” — is that they sound better and more realistic. For example, REVERB emulates the sound created by a room or hall. So, logic dictates that if we're going to add it to our sound, the closer to the end of the signal chain we put it, the more “real” and natural it's going to sound. The same is true for DELAY and MODULATION effects — they're going to sound more natural if added near the end of your signal path, not at its beginning. Also, if you're

---

using a crunch or high gain lead sound then it makes much more sense to add effects like ROTARY, ROOM (reverb), or DELAY after it's been distorted, rather than before.

## 1.2 INSERT button

Use this button to turn the insert effect on/off. This will be lit if the signal input/output to the external effect is ON, or dark if it is OFF. The external effect is placed before the pedal effect.

## 1.3 CAB (CABINET) button

Use this button to select a cabinet model or turn the cabinet model on and off.

While this button is blinking, you can use value knob 1 to select a cabinet model.

If you press the CAB button while holding down the AMP button, then you can use value knob 3 to adjust the presence, and value knob 4 to adjust the noise reduction, and value knob 6 to adjust the volume level of the programs.

## 1.4 PEDAL selector, select button

This lets you select one of the sixteen pedal effect models ToneLab LE offers. When you turn the PEDAL selector, the PEDAL select button will blink, and you can use value knobs 1–6 to adjust the pedal effect parameters. (For an explanation of each effect, refer to p.34–.) As stated before, pedal effects are connected before the amp.

**NOTE:** The parameters will be initialized when you switch effect types.

## 1.5 AMP selector, select button

This lets you select from sixteen types of classic amp models, including the legendary VOX AC30TBX. (For details, see p.27.) When you turn the AMP selector, the AMP select button will blink, and you can use value knobs 1–6 to adjust its parameters.

If you press the CAB button while holding down the AMP button, you can use value knob 3 to adjust presence and value knob 4 to adjust the NR (noise reduction) effect, and value knob 6 to adjust the volume level of the programs.

The operating mode of the preamp and power amp, the response of the tone controls, and their placement within the circuit will change depending on the type of amp you select here, precisely replicating the exact gain and tonal character of the original amp. The all-important power amp stage (class A or AB) and negative-feedback circuit (or lack thereof) are also carefully simulated.

## 1.6 MODULATION selector, select button

This selects one of eleven modulation effect models. When you turn the MODULATION selector, the MODULATION select button will blink, and you can use value knobs 1–6 to adjust the parameters of the modulation effect. (For details on each effect, refer to p.37–.)

**NOTE:** The parameters will be initialized when you switch effect types.

## 1.7 DELAY selector, select button

This selects one of eleven delay effect models. When you turn the DELAY selector, the DELAY select button will blink, and you can use value knobs 1–6 to adjust the parameters of the delay effect. (For details on each effect, refer to p.41–.)

**NOTE:** The parameters will be initialized when you switch effect types.

## 1.8 REVERB selector, select button

This selects one of eleven reverb effect models. When you turn the REVERB selector, the REVERB select button will blink, and you can use value knobs 1–6 to adjust the parameters of the reverb effect. (For details on each effect, refer to p.44–.)

**NOTE:** The parameters will be initialized when you switch effect types.

---

## 2 EDIT SECTION

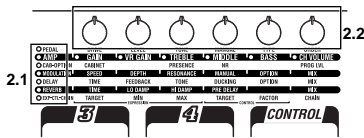

### 2.1 Edit category LEDs

One of the LEDs will light up to indicate the category of effect you are currently editing. Alternatively, an LED will light up to indicate the line of parameter names that you are currently adjusting.

### 2.2 Value knobs 1–6

Use these to adjust the parameters of the effects or amp model. Your adjustments will modify the effect whose MODEL select button you pressed (i.e., the button that is blinking). The LEDs below the knobs will light to indicate the knobs that are available.

The LEDs below the knobs will blink to indicate that the knobs are available to adjust the parameters on the name display.

For details on the parameter controlled by each knob, refer to p.34–. (From the left, we refer to these as value knobs 1–6.)

When the EXP-CTL-CHAIN button is blinking, these knobs adjust the corresponding functions.

When you are making RENAME or GLOBAL settings, or when executing the WRITE operation, you can use value knob 6 to change values.

## 3 DISPLAY SECTION

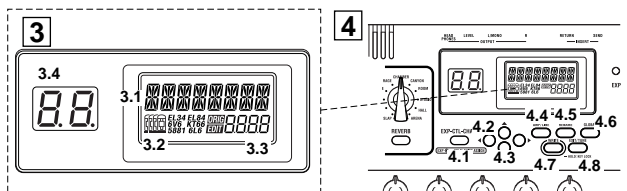

### 3.1 Name display

Displays program names, effect names, or parameter names.

### 3.2 Valve icon

Indicates the number and type of power valve — a.k.a. “vacuum tube” — used in the original amp that is being modeled.

### 3.3 Value display

Indicates the value of the parameter you are editing.

If the displayed parameter value matches the original value (i.e., the value saved in the program), the ORIG (original value) icon will appear.

**HINT:** The value display indicates the AMP/LINE setting after you turn on the power to the unit or when you select a different program.

### 3.4 Bank display

Indicates the bank number. If the tuner is operating, this indicates the note name. (p.46)

## 4 SETTING/GLOBAL SECTION

### 4.1 EXP-CTL-CHAIN button

Use this button to make expression pedal or control switch settings. Alternatively, use this button to change the chain setting, that is, the connection order of the modulation, delay, and reverb effects.

Use value knobs 1–3 to edit the expression pedal target parameter and the control range parameter.

Use value knobs 4–5 to edit the control switch target parameter and the FACTOR parameter. Use value knob 6 to make the chain setting.

You can also use the ▲, ▼ buttons to edit the value.

If this button indicator lights up while you're editing, it indicates that the expression pedal Quick Assign function is available.

**HINT:** [Quick Assign] If the EXP-CTL-CHAIN button is lit while you are editing an effect, you can use the expression pedal Quick Assign function. To assign the parameter shown in the name display to an expression pedal, hold down the EXP-CTL-CHAIN button for one second. When the assignment is complete, the name display will indicate COMPLETE.

### 4.2 ▲, ▼ buttons

Use these to edit the value of parameters.

### 4.3 ◀, ▶ buttons

Use these to select the parameter you want to edit, or to edit the program name.

### 4.4 [AMP/LINE] button

Use this button to make the ToneLab LE output settings. If you selected “Ln2,” you can use a three-band equalizer to adjust tonal characteristics of the amp models.

### 4.5 RENAME button

Use this to change the program name (p.26).

Use the ◀, ▶ buttons to move between spaces (characters) in the display, and use value knob 6 or the ▲, ▼ buttons to change the character at that space.

### 4.6 GLOBAL button

Use this button to make pedal, MIDI, or digital output settings.

Press the GLOBAL button and use the ◀, ▶ buttons to move through the menu items in the order shown below. After you have selected a menu item, use value knob 6 or the ▲, ▼ buttons to adjust the value.

EXP INIT:	Specifies the expression pedal operation during Program Change	(p.48)
MIDI CH:	Specifies the MIDI channel	(p.51)
PCHG OUT:	Specifies the program change message output setting	(p.51)
CCHG I/O:	Specifies the control change message input/output setting	(p.52)
SYEX OUT:	Specifies the system exclusive message output setting	(p.52)
DUMP CUR:	Dumps the current program data from the MIDI OUT connector	(p.53)
DUMP ALL:	Dumps all of ToneLab LE's data from the MIDI OUT connector	(p.53)
DOUT LVL:	Specifies the digital output level.	(p.20)

### 4.7 WRITE button

Use this when you want to save the settings you've created (p.26).

### 4.8 EXIT/TUNE button

Use this to abort a program-write operation or to cancel a GLOBAL setting.

By pressing and holding this button for a longer time, you can activate/cancel the Key Lock function, which disables operation of the buttons, selectors, and knobs (p.23).

By pressing this button while the name display is indicating a program name, you can activate the tuner.

---

## 5 BANK/PROGRAM/SELECT SECTION

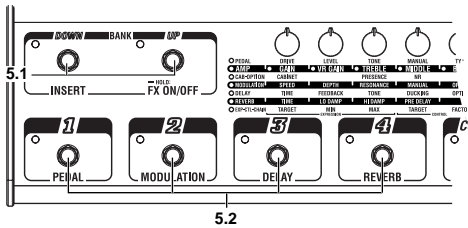

### 5.1 BANK UP/DOWN switches

In Program Select mode, press BANK UP to increment the bank by one, or BANK DOWN to decrement it by one. In Program Select mode, press and hold down BANK UP to enter Effect On/Off mode. The LED in the upper left of the switch lights up green. In this mode, you can use the BANK DOWN switch to toggle INSERT (the external effect) between On and Bypass. In Effect On/Off mode, press BANK UP to return to Program Select mode.

### 5.2 Program select switches, Program LEDs

Use these switches to select programs. The program LED in the upper left of each switch will light up red accordingly.

In Effect On/Off mode, you can use the program select switches to individually turn the pedal, modulation, delay, and reverb effects on or off. When the effects are turned on, the program LED in the upper left of the corresponding switches will light up green.

If you hold down the switch of the currently-selected program for 0.5 seconds or longer, the program LED blinks and the output of all effects will be bypassed. If you hold down this switch for one second or longer, the output will be muted. The tuner will operate when ToneLab LE is bypassed or muted.

To cancel bypass or mute, press this switch (the switch of the blinking program LED) once again.



---

## 6 EFFECT CONTROL SECTION

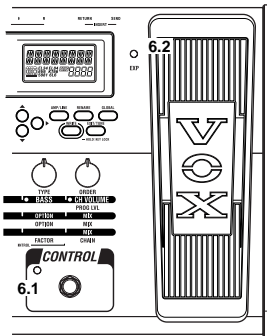

### 6.1 CONTROL switch

This switch controls the effect function specified by the Control switch target parameter.

### 6.2 EXP pedal (Expression pedal)

This pedal controls the effect parameter you assigned as the expression pedal target parameter (e.g., volume, wah, or other effect parameter). Pressing down firmly on an expression pedal will activate a switch underneath the pedal, allowing you to turn the assigned effect on or off (except when you've assigned the volume or an amp parameter).

The EXP LED located near the pedal lights up orange when the volume parameter is assigned to the pedal, and lights up green when the effect parameter is assigned to the pedal. The LED turns off if the target effect is turned off.

---

## REAR PANEL

### 7 REAR PANEL SECTION

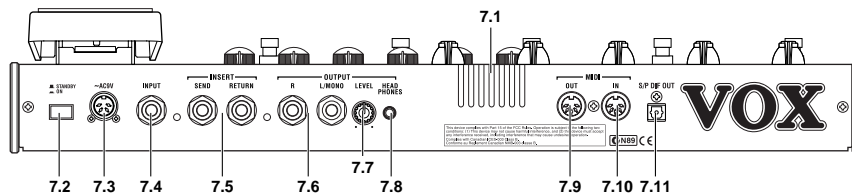

#### 7.1 Valve

ToneLab LE contains a 12AX7 (ECC83) valve (“vacuum tube”).

**NOTE:** The valve cover or the valve may break if either is subjected to impact.

If the valve cover breaks, please have it replaced. Failure to replace a damaged valve cover may lead to the valve itself becoming damaged.

#### 7.2 STANDBY switch

Turns the power on/off.

#### 7.3 ~AC9V

Connect the included AC/AC power supply here.

#### 7.4 INPUT jack

Connect your guitar to this jack.

#### 7.5 INSERT jacks (SEND, RETURN)

You can connect an external effect processor or stompbox to these jacks.

Connect SEND to the input of your external effect device.

Connect RETURN to the output of your external effect device.

#### 7.6 OUTPUT jacks (L/MONO, R)

These are analog output jacks. If you’re using a mono output, connect the L/MONO jack.

#### 7.7 LEVEL knob

Adjusts the output level from the OUTPUT jacks and the HEADPHONES jack.

#### 7.8 HEADPHONES jack (stereo)

Connect your headphones to this jack.

#### 7.9 MIDI OUT connector

This connector transmits MIDI data. Use it when you want to control a connected external MIDI device.

#### 7.10 MIDI IN connector

This connector receives MIDI data. Use it when you want to control ToneLab LE from a connected external MIDI device.

#### 7.11 S/P DIF OUT connector

This connector transmits S/P DIF optical digital data.

# Setup

**NOTE:** You must turn off the power of all your equipment before you make connections. If you ignore this warning, you may damage your speaker system or experience malfunctions!

## BASIC CONNECTIONS

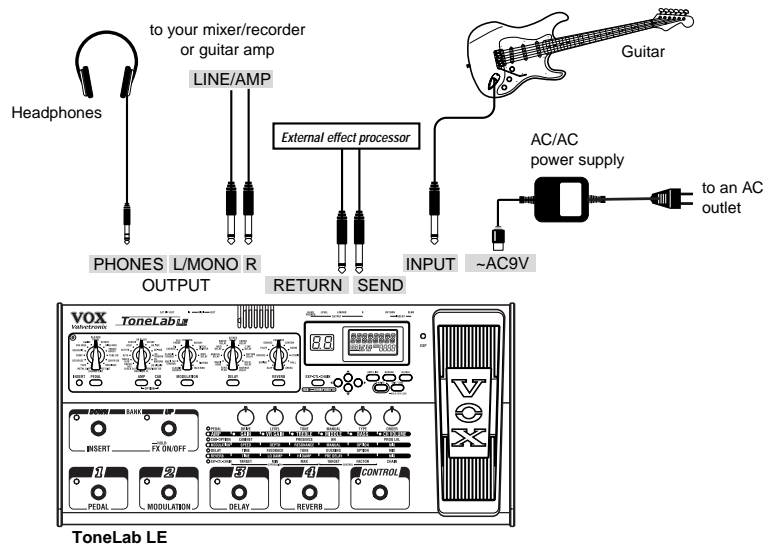

1. Use audio cables to connect ToneLab LE's OUTPUT L/MONO and R jacks (7.6) to a mixer/recorder or guitar amp. If desired, you can also connect an external effect processor. To do this simply connect SEND to the input of your external processor, and RETURN to the output of your external processor.

**HINT:** If you're making connections in mono, use the OUTPUT L/MONO jack. However to take the fullest advantage of ToneLab LE's sound, we strongly recommend that you use stereo connections.

If you are using headphones, plug them into the HEADPHONES jack (7.8).

**NOTE:** Signal from the OUTPUT jack(s) will still be heard even if headphones are plugged in. If you only want to hear signal from headphones you must disconnect any cables from the Output jacks or turn off or lower any equipment ToneLab LE is connected to.

2. Turn the LEVEL knob (7.7) located on the rear panel of ToneLab LE all the way toward the left (as seen from the rear), setting the volume to 0.
3. Connect the included AC/AC power supply to the rear panel AC9V power supply jack (7.3), and then connect the plug to an AC outlet.
4. Plug your guitar into the rear panel INPUT jack (7.4).
5. Turn down the volume of your amp or mixer so you don't hear crackles or pops when the power is turned on. Then turn on the STANDBY switch (7.2) to turn on the power.
6. If you have connected ToneLab LE to a mixer/recorder, press the AMP/LINE button, then use value knob 1 or the ▲, ▼ buttons to select "Ln1" or "Ln2" (LINE). If you've connected ToneLab LE to a guitar amp, select one from "AP1"–"AP3" (AMP).

**HINT:** If you have connected only the headphones, select "Ln1" or "Ln2" for the AMP/LINE setting.

- To adjust the volume, turn up your amp or mixer and ToneLab LE's rear panel LEVEL knob to a desired level (7.7).

**NOTE:** Since ToneLab LE uses an actual valve (vacuum tube), it will produce no sound for several seconds until the valve warms up. This isn't a malfunction — it's just the nature of valves.

**HINT:** If ToneLab LE is connected immediately preceding a combo or head amp, set the tone controls of your guitar amp to their center positions, adjust the amp accordingly to avoid unintentional distortion. Then, bypass ToneLab LE, and adjust the rear panel LEVEL knob so that the volume level is the same as when your guitar is connected directly to the amp.

**HINT:** If you're connecting ToneLab LE to a guitar amp that has a jack allowing you to connect directly before the power amp (such as Return or Main In), set the AMP/LINE menu item to "Ln1" or "Ln2" (LINE), and then connect ToneLab LE to that jack. If you want to take advantage of the tonal character of that amp (and cabinet), you may want to turn ToneLab LE's CABINET setting "OFF."

**HINT:** When the program name is displayed, you can press and hold the EXIT/TUNE button for one second or longer to activate the Key Lock function. This function disables operation of the buttons, selectors, and knobs. To cancel the Key Lock function, press and hold the EXIT/TUNE button again for one second or longer. (p.23)

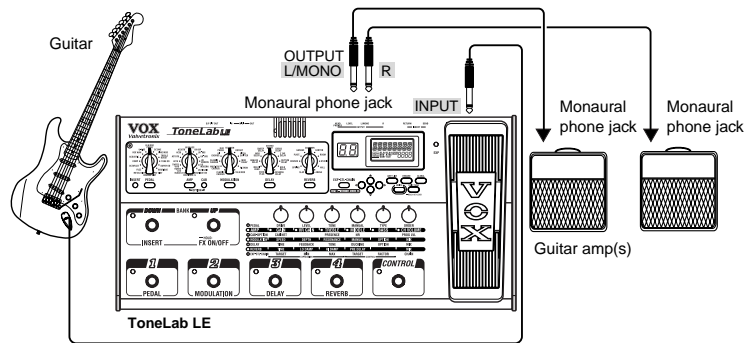

## USING THE S/P DIF CONNECTOR

By using the S/P DIF connector, you can transmit digital data between ToneLab LE and a connected device, such as a recorder.

### ADJUST THE DIGITAL OUTPUT LEVEL

- Press the GLOBAL button.
- Repeatedly press the ► button until the display reads "DOUT LVL."
- Use value knob 6 or the ▲, ▼ buttons to set the output level at the S/P DIF connector.

**HINT:** You can specify a level between -12 and +12. Level "0" (0dB) is nominal. Setting the level above "0" may distort the sound of some programs.

## USING TONELAB LE WITH A MIDI DEVICE OR COMPUTER

By using MIDI you can control ToneLab LE from a sequencer or control an external MIDI device from ToneLab LE. You can also save ToneLab LE programs on a sequencer or MIDI data file that is able to transmit and receive MIDI exclusive data, and then load the program data back into ToneLab LE when desired.

**HINT:** For details on MIDI connections refer to p.51.

---

## OUTPUT SETTINGS

Here's how to specify whether you're connecting ToneLab LE to a guitar amp or to a mixer/recorder. This procedure is required to make the necessary adjustments to the guitar amp model output signal according to the device to which the ToneLab LE is connected.

1. Press the AMP/LINE button (and use the ◀ and ▶ buttons, if necessary) to make the display read "AMP/LINE."

2. Use value knob 1 or the ▲, ▼ buttons to set the value.

AP1: Select this if you are using an amp that features a clean sound, such as a US-made open-back combo.

AP2: Select this if you are using an amp that features a strong and distinctive mid range, such as a UK-made open-back combo.

AP3: Select this if you are using a stack-type amp, such as a 4x12" closed-back cabinet.

Ln1: Select this if you are using the ToneLab LE S/P DIF OUT connector or connecting a guitar amp's power amp input or a recorder to a Line output.

Ln2: Select this if you would like to adjust the sound by using the three-band EQ.

**NOTE:** The AMP/LINE setting is disabled if an amp model you selected is turned off.

**NOTE:** The amps mentioned above are merely representative. The optimum setting varies depending on the type and settings of your amp.

---

# Playing ToneLab LE

## PROGRAM SELECT MODE

ToneLab LE has 120 programs (30 banks x 4 programs), and every one of these programs can be totally rewritten or “custom tweaked” to your heart’s content. With the factory settings, banks 1–10 contain a total of 40 preset programs. (Banks 11–20 and 21–30 contain the same preset programs as banks 1–10.)

In order to select programs, you need to be in Program Select mode.

### SELECTING A PROGRAM

As an example, here’s how to select program 2-3 (bank 2, program 3).

1. Make sure that ToneLab LE is in Program Select mode.  
If the BANK UP switch LED is lit green, you’re in Effect On/Off mode. Press the BANK UP switch to change to Program Select mode. In Program Select mode, the BANK UP and DOWN switch LEDs will be dark.
2. Use the BANK UP/DOWN switches (5.1) to select bank 2.  
The bank number in the bank display blinks.
3. Press the program select 3 switch (5.2).  
Program 2-3 will be recalled instantly. The program select 3 switch LED will light, and the bank number will light steadily.  
**HINT:** When you’ve selected the Bank but not the Program, the previously-selected program is still active. So if you’re playing live and your next program change requires you to switch to a different bank, you can select that bank ahead of time, ensuring a timely, seamless change.

## EFFECT ON/OFF MODE

You can use program select switches 1–4 to switch the pedal effect, modulation effect, delay effect, and reverb effect of the current program on/off individually. Also, you can use the BANK DOWN switch to switch the signal that is being sent through the external effect processor connected to the INSERT jacks.

**HINT:** You can turn the current amp model on or off using the CONTROL switch. (p.49)

**HINT:** When you want to switch programs, press the BANK UP switch again to return to Program Select mode.

### SWITCHING EFFECTS ON/OFF

As an example, here’s how you can switch the pedal and insert effects on/off for the current program.

1. If the BANK UP and DOWN switch LEDs are dark, the unit is in Program Select mode. Press the BANK UP switch to enter Effect On/Off mode. The BANK UP switch LED lights up green.  
Program LEDs 1–4 and the BANK DOWN switch LED indicate the on/off status of the pedal effect, as well as modulation, delay, reverb and insert effects.
2. If program LED 1 is lit, the pedal effect is ON. If you press program select switch 1, the pedal effect will turn off and LED 1 will go dark.
3. If the BANK DOWN switch LED is dark, your guitar signal is not being sent through the external effect. When you press the BANK DOWN switch, the external effect send/return will be turned ON, and the BANK DOWN switch LED will light.

---

**NOTE:** If you haven't connected an external effect processor to the INSERT RETURN jacks, the INPUT signal will bypass the insert circuit whether the INSERT button LED is lit or dark.

## ACTIVATING OR DEACTIVATING THE KEY LOCK FUNCTION

Here's how you can use the Key Lock function to disable ToneLab LE's buttons, selectors, and knobs so they can't be accidentally changed during a live performance.

**NOTE:** While the Key Lock function is activated, you won't be able to operate any controls except for the switches, pedals and the EXIT/TUNE button.

**NOTE:** The Key Lock setting is cancelled when you turn off the power; it will be disabled when you turn on the power once again.

### ACTIVATING THE KEY LOCK FUNCTION

1. If the name display shows anything other than a program name, or if the characters of the program name are blinking, press the EXIT/TUNE button.
2. With the program name shown in the name display, press and hold the EXIT/TUNE button for at least one second.

The name display will indicate KEY LOCK for one second, and then the value knob LEDs will go dark.

### DEACTIVATING THE KEY LOCK FUNCTION

1. If the name display shows anything other than a program name, press the EXIT/TUNE button.
2. Press and hold the EXIT/TUNE button for at least one second.

The name display will indicate LOCK OFF for one second, and then the value knob LEDs will light.

---

# Creating and Storing your own Programs

There are two ways you can do this; by “tweaking an existing program” or by “starting from scratch.”

## CREATING YOUR OWN PROGRAM

### TWEAKING AN EXISTING PROGRAM

If you want to tweak an existing program, select one that’s close to the sound you want. Set the MODEL select buttons to the amp, cabinet and effects you want to use, and use value knobs 1–6 to adjust the sound.

For example, you might start with a certain preset that has a crunchy, modern rhythm sound that you like, but create a complementary lead sound that is louder, has a bit more gain, and boosted mid-range.

### CREATE YOUR OWN PROGRAM

Now here’s how to create your own program from scratch.

**NOTE:** Before you continue, make sure that the AMP/LINE menu is set correctly as described on p.19.

1. Select any program (p.22).

**HINT:** It doesn’t matter which program you select, because we’re starting from scratch.

2. In the PEDAL, MODULATION, DELAY, REVERB section, press any model select button that is lit two times. This will turn off (bypass) all effects other than the amp model.

3. Use the AMP MODEL selector to choose the amp you want.

**HINT:** For details on amp types, cabinet types, and effect types, refer to “Explanations of the Amp, Cabinet and Effect Types” (p.27).

4. Use value knobs 1–6 to adjust the GAIN, VR GAIN, TREBLE, MIDDLE, BASS, and CH VOLUME as desired. CH VOLUME adjusts the volume while preserving the overall character of the sound, including the distortion of the power stage. To adjust the PRESENCE, press the AMP button while holding down the CAP button, then turn value knob 3. To return to adjusting GAIN etc., press the AMP model select button.

**HINT:** The key to getting the most accurate vintage tube amp distortion is to raise the VR GAIN.

**NOTE:** Some settings may cause your output sound to be distorted (i.e., in a way you don’t intend). If so, lower the CH VOLUME.

5. Press the CAB button, then turn the value knob 1 to choose a cabinet.

**HINT:** For recommended combinations of amp types and cabinet types, refer to p.32.

6. Press the CAB button while holding down the AMP button, and adjust the NR SENS (value knob 4) appropriately. Higher values of noise reduction (0.2, 0.4, ... 10.0) will produce a correspondingly greater effect. With a setting of “OFF” there will be no noise reduction.

**NOTE:** We recommend that you use noise reduction if you’re using a high-gain setting such as the US MODERN or US HIGAIN amp type, since high gain usually generates more noise. Depending on the guitar you’re using, raising the noise reduction excessively may cause some of your notes to be cut off unnaturally.

7. In each section, choose the effect you want to use. For example if you want to add spring reverb, use the REVERB selector to select SPRING.

**HINT:** When you do so, the reverb model will automatically be turned on. The REVERB parameter line LED of the edit section and the LEDs below the value knobs will light to indicate the REVERB parameters. For example if you selected SPRING, value knobs 1–4 will control TIME, LO DAMP, HI DAMP, and PRE DELAY, while value knob 6 will control MIX.



8. To adjust the reverb mix amount, use value knob 6 which controls the MIX parameter. In the same way for PEDAL, MODULATION, and DELAY effects, use the selector to choose an effect and the value knobs to adjust the parameters.
 

**HINT:** In some cases, it's easier to adjust the PEDAL effect if modulation, delay, and reverb are not being applied. If you're using the PEDAL effect, it's best to make your amp and cabinet settings first, and then adjust the pedal effect before the other effects.

**NOTE:** For some of the models, the name of the actual parameter you will be editing may differ from what is printed in the parameter line of the edit section. The name that appears in the display when you operate a value knob is the actual name. For details on parameters refer to p.34.
9. If you want to continue making adjustments, simply press the select button for the model you want to edit, and turn the value knobs.
 

**HINT:** If the EXP-CTL-CHAIN button lights when you operate a value knob, you have the option of assigning that parameter to an expression pedal. If you press and hold the EXP-CTL-CHAIN button for at least one second, the parameter will be assigned to the expression pedal (EXP). (We call this the Expression Pedal Quick Assign function.) For example if you set the PEDAL model selector to U-VIBE and use value knob 1 to adjust the SPEED parameter, the EXP-CTL-CHAIN button will light to indicate that you can use the above method to assign the SPEED parameter to the expression pedal. For details, refer to p.47.

**NOTE:** If you've used the PEDAL selector to select VOX WAH, the MANUAL parameter will automatically be assigned to expression pedal (EXP), letting you use the pedal as a wah pedal.
10. If you notice that the volume level of a specific program is different from that of other programs and you wish to adjust the level, press the CAB button while holding down the AMP button, then turn the PROG LVL knob (value knob 6). You can also apply this procedure if some effect settings cause sound clipping.

## CHANGING THE CONNECTION ORDER OF THE EFFECTS (CHAIN)

You are free to change the order in which the modulation effect, delay effect, and reverb effect are connected.

The effect connection order is saved independently for each program.

1. Press the EXP-CTL-CHAIN button, then use the ◀ and ▶ buttons to make the value knob 6 LED blink. The current connection order is displayed.
2. Use value knob 6 or the ▲, ▼ buttons to change the order.

<b>Display</b>	<b>Connection order</b>
MD-DL-RV	modulation→delay→reverb
MD-RV-DL	modulation→reverb→delay
DL-MD-RV	delay→modulation→reverb
DL-RV-MD	delay→reverb→modulation
RV-MD-DL	reverb→modulation→delay
RV-DL-MD	reverb→delay→modulation

## USING THE THREE-BAND EQUALIZER

If you selected “Ln2” for the “AMP/LINE” setting, you can use the three-band equalizer to adjust the overall tonal characteristics of the sound output from ToneLab LE.

When you select “Ln2” for the “AMP/LINE” setting, the value knobs 2–6 feature the following functions:

Value knob 2	“TRIM”	Adjusts the input level.
Value knob 3	“LO GAIN”	Adjusts the amount of low-range boost.
Value knob 4	“MID FREQ”	Specifies the mid-range frequency.
Value knob 5	“MID GAIN”	Adjusts the mid-range boost.
Value knob 6	“HI GAIN”	Adjusts the high-range boost.

**NOTE:** The equalizer is unavailable if you selected “AP1,” “AP2,” “AP3,” or “Ln1” for the “AMP/LINE” setting.

---

**NOTE:** The equalizer is unavailable if an amp model you selected is turned off.

## NAMING A PROGRAM

Here's how you can name a program.

**NOTE:** The program name is saved as part of each program. If you switch to a different program or turn off the power before you save, your settings will be lost.

1. Press the RENAME button.
2. Use the ◀, ▶ buttons to move the cursor to the character you want to change (the selected character blinks), and use value knob 6 or the ▲, ▼ buttons to change the character. You can use the following characters.

!"#\$%&'()\*+,-./0123456789-:;?@  
ABCDEFGHIJKLMNPOQRSTUVWXYZ[\]^\_`

3. Repeat step 2 to finish entering a name for your program.
4. When you've finished entering a name, press the EXIT/TUNE button (4.8) to return to the mode you were in.

## STORING A PROGRAM

When your tweaking has resulted in a sound you're happy with, store (write) it!

1. Press the WRITE button (4.7).  
The name display (3.1) shows "\*\*WRITE\*" and the bank display (3.4) and one of program LEDs 1–4 will blink.
2. Use value knob 6 (2.2) or the ▲, ▼ buttons (4.2) to select the bank you want to use, and use the ◀, ▶ buttons to select the destination program (1–4).  
For example if you want to store your program in 9-1 (bank 9, program 1), use value knob 6 or the ▲, ▼ buttons to make the bank display show "9," and then use the ◀, ▶ buttons to make the program 1 pedal LED blink.  
**HINT:** You can also select the store-destination program by using the BANK UP/DOWN switches or the program 1–4 select buttons.

3. Press the WRITE button (4.7) once again.  
The name display will indicate "COMPLETE." Your program is now stored, and you'll be back in Program Select mode.

**NOTE:** The program is written over the previous contents of that bank/program. The program that previously occupied the number you selected in step 2 will be erased.

**NOTE:** If you decide not to store your new program, press the EXIT/TUNE button (4.8) to cancel the procedure.

**NOTE:** If you switch to a different program or turn off the power without storing the program you edited, your changes will be lost.

## RESTORING A SETTING TO ITS ORIGINAL VALUE

The Original Value icon in the value display (3.3) gives you a way to find out the parameter values that are stored in a program.

When you are using a knob or button to change the value of a parameter, the ORIG (original value) icon will appear when the value you are adjusting matches the "original value" stored in the program.

**HINT:** So, you're flipping through the programs on your new ToneLab LE, and you come across one you really like. It's easy to find out exactly what settings are dialed in to get such an awesome tone — just use this Original Value display feature!

# Explanations of the Amp, Cabinet and Effect Types

This section explains ToneLab LE's amp models, pedal effects, cabinet models, modulation, delay, and reverb effects.

## A. AMP MODELS

Which amps did we painstakingly model for our seductive selection of 16? Believe me when I say it wasn't easy 'cos, as I'm sure you know, there's a plethora of great sounding amps out there. After countless hours of soul searching, earnest discussions (not to mention the occasional friendly argument!), calls to tone-wise friends (some professional players, some not...but all blessed with great ears) plus, of course, listening and playing, a top 16 list was finally drawn up. As you're about to discover, the ones we went with are not only the cream of the crop but also offer up the widest possible array of the greatest guitar tones known to man — from pristine clean to outrageous overdrive and all points in-between. First though, some stuff you should know...

### CONTROLLING FACTORS

As already touched on in this manual, although the amp model of your ToneLab LE houses controls for GAIN, VR GAIN, TREBLE, MIDDLE, BASS, PRESENCE and CH VOLUME, not all of the amps we've modelled have as many controls. In such cases, rather than leave you with knobs that do nothing (what on earth would be the point of that!?), we've made full use of all six (6) ToneLab LE controls *without* compromising the accuracy of any of our models. This means you'll be able to mimic the full tonal spectrum of each and every one of the originals we've modelled...and then some, thanks to the extra flexibility and additional control the six ToneLab LE controls give you.

For example, if an original amp doesn't have a complete 3 band EQ network then we'll set up the "missing" tone controls on our model to be "neutral" (i.e. as the original) when set at 12 o'clock — thus giving you extra tonal flexibility in

those EQ areas, if you so wish. Just so you know, the amps we modelled that don't have individual controls for Treble, Middle and Bass are:

AMP	ORIGINAL TONE CONTROLS
AC15	Top Cut & Bass Cut Switch
AC15TB	Treble & Bass
AC30	Top Cut only
AC30TB	Treble, Bass and Cut
TWEED 1x12	Just one, called Tone!

Also, as you'd probably expect, we do the same exact thing with the ToneLab LE's PRESENCE control too — namely, if one isn't present (bad pun, not intended!) on the original then PRESENCE will be an added control on our model. This time though, the "neutral" position is when the control is all the way off (turned fully counter-clockwise). The two models this applies to are BLACK 2x12 and TWEED 1x12.

### IMPORTANT NOTE:

As you'll discover when you read their descriptions, in the case of the AC15, AC15TB, AC30 and AC30TB models, we've utilized the PRESENCE control to mimic the TOP CUT control — whether it was present on the original or not.

### ABOUT THE GAIN AND VOLUME KNOBS

ToneLab LE's amp models provide three programmable knobs that affect the volume (gain); GAIN, VR GAIN, and CH VOLUME. Each control has its own specific job, and the sound of a particular amp model can vary over an amazingly wide range just depending on the settings of these knobs.

As some of you will know, most vintage amps only have one VOLUME control to set up the sound, whilst more modern amps usually have two types of level controls — GAIN (or sometimes PREAMP VOLUME) that controls the input level of the preamp section, and MASTER VOLUME that controls how much signal is (and how loud it is going to be) passed from the preamp to the power amp. With many vintage amps there is no MASTER VOLUME, the preamp feeds directly into the power amp without any type of control.

The ToneLab LE's controls are designed to cover all these points:

ToneLab LE GAIN: On vintage type models that do not have a master volume (i.e., AC15, AC15TB, AC30, AC30TB, UK BLUES, UK 68P, BLACK 2x12, TWEED 1x12, TWEED 4x10), the GAIN control works like the VOLUME of the original amp. On models that do have a master volume, the GAIN control works like GAIN or PREAMP VOLUME.

---

ToneLab LE VR GAIN: MASTER VOLUME that controls how much preamp signal level is passed to the power amp, which in our case is the VALVE REACTOR stage. (Your ToneLab LE works like a real amp.)

ToneLab LE CH VOLUME: For want of a better way of putting it, this is like a power attenuator that you would add between the output of your amp and the input of your speaker cabinet. This controls the level of the final mix and allows you to balance all your programmed amp sounds to each other.

As in how the original amps work, we have made the relationship between preamp and power amp work in the same way. Therefore to obtain truly authentic tones please use the VR GAIN control in the same way, i.e. with VINTAGE type models that do not have Master Volume control's, turn the VR GAIN control up to maximum.

When using a model of a modern amp that does have a master volume control, adjust VR GAIN just as you would adjust the master volume control. Low settings of VR GAIN will tend to produce more of a preamp distortion, while high settings will add the distinctive distortion and warmth of the Valve Reactor.

Lastly, if an original amp features a unique switch or control we make sure that we cover it! Such things will be revealed in the model descriptions that follow shortly...

## TUBE TALK

Us Brits call 'em valves while our US cousins call 'em tubes...as the saying goes: England and America are merely two countries divided by a common language! Anyway, call 'em what you will, these wondrous glass bottles lie at the tonal heart of each of our 16 models. As all the amps we've modelled hail from one of the two countries just mentioned, in honour of their heritage, the descriptions of all English amps will employ the words "valve" and "valves," while the American ones will be tubular!

**QUESTION:** What's the difference between an ECC83 preamp valve and a 12AX7 preamp tube?

**ANSWER:** Nothing! They're the same exact thing — namely the most popular preamp tube in ampland. ECC83 is the British name, 12AX7 (a.k.a. 7025) is the American. See, I told you we were two countries divided by a common language!

## POWER AMP ACCURACY

What happens in the power stage of any good tube amp is of *paramount importance* to the way the amp sounds, feels and behaves. The way the power amp operates (Class A or Class AB), the power tubes used (EL84s, EL34s, 6L6s, 6V6s), the exact nature of the negative feedback loop circuitry (if one even exists) and how the power stage interacts (a relationship called damping) with the speaker(s) it is driving — all these things play a vital role in the creation of *tone*. That is why we have fitted your ToneLab LE with our patented **Valve Reactor Technology** — a modelling breakthrough that is unique to VOX and infuses our critically acclaimed Valvetronix range of amps with life and feel. This revolutionary technology emulates a tube power-amp by using real tubes in a real tube amp circuit and ensures that all the important bases inherent in a tube amp are faithfully and accurately covered. For example: if you choose amp model AC30TB — an amp with a Class A power stage, EL84 output tubes and no negative feedback, that's exactly what your *Valve Reactor* power amp reconfigures itself to be.

This all said, let's take a look at each of our amp models...

## 1. AC15

This is based on Channel 2 of a 1962 1x12", 15 Watt VOX AC15 which only has three controls — Volume, Brilliance and Top Cut. ToneLab LE's GAIN control mimics the original's Volume control, while the PRESENCE control acts as the Top Cut.\* The BASS control acts as the Bass Cut with total variability. Set the "extra" TREBLE and MIDDLE controls at 12 o'clock and they're "neutral" or tweak them for extra tonal flexibility.

### \*CONTROL NOTE:

The original AC15's Top Cut control works in the opposite way you'd expect — it "cuts" when you turn it up! You'll be glad to read that our Top Cut control (the PRESENCE knob) works in a much more logical fashion — turn it up for more "sparkle," turn it down for less.

**Original's valve compliment:** 1 x EF86, 3 x ECC83s, 1 x ECC82 in the preamp, 1 x EZ81 rectifier, 2 x EL84s in the power amp.

## 2. AC15TB

The AC15TB is a modern-day amp which combines the tonal characteristics of the AC15's low Wattage power stage, with the increased tonal flexibility that the Top Boost (TB) channel of an AC30 has to offer. Then, to sweeten the pot even further, a 12" Celestion "Blue" speaker, Reverb and a Master Volume control were thrown in too. The original has two tone controls—Treble and Bass. So, as is the norm, the ToneLab LE's TREBLE and BASS controls mimic their namesakes while the MIDDLE ("neutral" at 12 o'clock) and PRESENCE add further tonal flexibility. To ensure maximum "Voxiness," we've made sure that the PRESENCE control behaves exactly like the "Top Cut" on the original AC15 — except in reverse ("off" = cut) to make it more logical, just like on our AC15 model. In trademark VOX fashion, our AC15TBX model oozes clean tones that "jangle" and "chime," while its overdrives are smooth yet pulsating with desirable harmonic overtones.

**Original's valve compliment:** 5 x ECC83s in the preamp, 1 x 5Y3GT rectifier, 2 x EL84s in the power amp.

## 3. AC30

This amp is based on the Normal channel of a 1959 30 Watt, 2x12, AC30. The AC30's Normal channel boasts the bare minimum of knobs — Volume and Top Cut (GAIN and PRESENCE\* respectively).

**\*CONTROL NOTE:**

Once again, our PRESENCE control styles the "Top Cut" on the original AC30 exactly — except in reverse ("off" = cut) to make it more logical, just like on our AC15 model.

**Original's valve compliment:** 4 x ECC83s, 1 x ECC82 in the preamp, 1 x GZ34 rectifier, 4 x EL84s in the power amp.

## 4. AC30TB

The Brilliant channel of an AC30TB includes extra tone circuitry that features an additional ECC83 valve called "Top Boost" and two extra EQ controls, giving the amp three tone controls — Treble, Bass and Cut. Once again, the PRESENCE control of our model acts as the original's Cut (but in reverse: "off" = cut) while the GAIN, TREBLE and BASS mimic the original's Volume, Treble and Bass controls. The MIDDLE is an "extra" with 12 o'clock being its "neutral" position. Our AC30TB produces clean sounds that are rich and jangly with a smooth yet detailed top end, and overdrives that have a glorious, throaty bark — just like those classic, "Class A" tones.

**Original's valve compliment:** 5 x ECC83s & 1 x ECC82 in the preamp, 1 x GZ34 rectifier, 4 x EL84s in the power amp.

## 5. UK BLUES

Our UK BLUES is based on the "High Treble" channel of an extremely rare, handwired head made in England in the early '60s. Although the TWEED 4x10 circuit was used as a basic template for this amp, several fundamental changes (e.g. different tubes, different transformers, a higher output impedance and vastly different speakers in a closed-back cab), give UK BLUES its own unique and highly desirable character.

**Original's valve compliment:** 3 x ECC83s in the preamp, 1 x GZ34 rectifier, 2x KT66s in the power amp.

## 6. UK 68P

This is based on the "High Treble" channel of a 4 input, 1968, 50 Watt, all-valve head. It doesn't feature a Master Volume control so the best way to set it up is to max out the volume! To achieve the same response as the original, remember to turn the VR Gain control to maximum. The ToneLab LE works EXACTLY like the original. So, wind the GAIN control all the way up and immerse yourself in an instantly recognizable, organic overdrive that responds beautifully to the subtle dynamics of your playing. Rolling back your guitar's volume control results in a unique and highly useable clean sound.

**Original's valve compliment:** 3 x ECC83s in the preamp, 2 x EL34s in the power amp.

## 7. UK '80S

This is based on a 1983, all tube, single channel 100 Watt head that boasts a Master Volume control. Invariably played with its (preamp) Gain control cranked, this amp will provide a fat, roaring sound. Although UK '80s became famous for its distinctive, cranium-crushing crunch, it isn't merely a "one trick pony" and neither is our model—just like the original, when you roll back your guitar's volume knob you'll get a bright, clean sound that's perfect for chord work and will cut through any mix.

**Original's valve compliment:** 3 x ECC83s in the preamp, 4 x EL34s in the power amp.

---

## 8. UK '90S

This model is based on the “lead” channel of a 100 Watt, dual channel head that is capable of so much preamp distortion it houses a Gain control that goes all the way up to 20! This amp replaced UK '80s and was developed to satisfy the ever-evolving rock guitarists' insatiable lust for more gain, features and flexibility.

**Original's valve compliment:** 3 x ECC83s in the preamp, 4 x 5881s in the power amp.

## 9. UK MODERN (UK MODRN)

This is based on the High Gain channel of a modern, all-tube 100 Watter that is effectively a hybrid of the UK '80s and UK '90s amps. It combines the toneful high gain preamp stage and modern features of UK '90s with the unmistakable, “snarling” punch and girth the UK '80s power stage had to offer.

**Original's valve compliment:** 4 x ECC83s in the preamp, 4 x EL34s in the power amp.

## 10. US MODERN

This is based on the “Modern High Gain” channel of a 100 Watt, head from California. Its deep, dark, loose low-end, some what “fizzy” top and Monster-like gain has made this amp a mainstay for many modern, acts. At low GAIN settings, it produces a distinctive, bright clean sound bolstered by some rich, upper harmonics that add fullness and dimension.

**Original's tube compliment:** 5 x 12AX7s in the preamp, 2 x 5U4G rectifier tubes, 4 x 6L6s in the power amp.

## 11. US HIGAIN (US HI-G)

This is based on the Overdrive Channel of an all-tube, 100 Watt snakeskin head. US HIGAIN is capable of a powerful, heavily saturated sound that combines an open low-end with compressed mids and highs. The result is a tone that remains focused and well defined at even the most extreme gain settings.

**Original's tube compliment:** 4 x 12AX7s in the preamp, 4 x 6L6s in the power amp.

## 12. BOUTIQUE OD (BTQ OD)

For this one we styled the Overdrive channel of a very rare and expensive 100 Watt head named the Overdrive Special. This hand-wired beauty has a spectacular overdriven sound that's perfect for sax-like, legato soloing. With its GAIN control wide-open, BOUTIQUE OD produces a stunning sustain which is very smooth and very soulful.

**Original's tube compliment:** 3 x 12AX7s in the preamp, 4 x EL34s in the power amp.

## 13. BOUTIQUE CL (BTQ CL)

For this amp, we styled the Clean channel of another very expensive, handwired, custom amp made by the same boutique builder as BOUTIQUE OD.

Its beautifully rounded low-end, delightfully transient midrange attack and sweet treble make it the perfect partner for single-coil pickups. It is also incredibly responsive and extremely sensitive to picking styles and pickup selection. And, as an added bonus, strummed chords just ring out and blossom.

**Original's tube compliment:** 3 x 12AX7s in the preamp, 4 x 6L6s in the power amp.

## 14. BLACK 2X12 (BLK 2X12)

The dual channel, BLACK 2X12's clean sound is very tight “n” twangy, with a deep, taut, piano-like bass. When pushed hard the bass tends to crumble. So, to emulate this classic, BLACK 2x12 overdrive, here's what you dial in on your ToneLab LE: full GAIN and VR GAIN, not much BASS, full MIDDLE and set TREBLE to taste. Because the EQ network of BLACK 2x12 lies before the main gain stage of its preamp, pushing the mids in this way emphasizes the distortion in that frequency range and the result is a lovely, singing blues tone. As already mentioned elsewhere, the original amp doesn't have a Presence control but does have a Bright Switch. The PRESENCE control on your ToneLab LE emulates this switch when “off” and “on,” plus all points in-between!

**Original's tube compliment:** 2 x 12AX7s & 2 x 7025s & 2 x 12AT7s (a.k.a. ECC81) in the preamp, 4 x 6L6s in the power amp.

### TONAL HINT:

BLACK 2x12 is the perfect partner for ACOUSTIC (Acoustic Guitar Simulator) in the Pedal section.

---

## 15. TWEED 1X12 (TWD 1X12)

The TWEED 1x12, 18 Watt, all-tube combo is the very essence of simplicity with a Volume knob and a single Tone control. This Tone control is merely a treble cut and boost, and its behaviour can be mimicked by using the ToneLab LE's TREBLE, MIDDLE and BASS EQ network as follows:

Original Tone control turned all the way down (off) = BASS on full; TREBLE and MIDDLE at 9 o'clock (PRESENCE "off").

Original Tone control turned up "full" (on 10) = TREBLE on full; MIDDLE and BASS at 9 o'clock (PRESENCE "off").

**NOTE:** As the original doesn't have a Presence control, PRESENCE is "neutral" when "off," but can be used to add "extra" sparkle and cut to the style if you so wish.

**Original's tube complement:** 1 x 12AY7, 1 x 12AX7 in the preamp, 1 x 5Y3GT rectifier, 2 x 6V6s in the power amp.

## 16. TWEED 4X10 (TWD 4X10)

TWEED 4x10 is very sensitive and responsive to both picking strength and the volume setting on your guitar. This means that by backing-off your axe's volume when the amp is cranked, you can produce a beautifully clean and full tone. It also means that dynamic picking control allows you to make notes or chords more distorted or clean than others, depending on how hard or how soft you pick. Another cool tonal quirk of TWEED 4x10 is the classic, vintage tube amp sag its GZ34 rectifier tube adds to your notes whenever the amp is driven really hard.

**Original's tube complement:** 1 x 12AY7, 2 x 12AX7s in the preamp, 1x GZ34 rectifier, 2 x 5881s in the power amp.

## B. CABINET MODELS

Now let's look at the CABINET models:

### CABINET AND SPEAKER ACCURACY

There's not much point in having incredibly accurate amp models if the speaker cabinet models on offer aren't of the same exacting standards. As you may know, in real life, the output stage of a tube amp works in close harmony with the varying impedance curve of the speaker(s) it is driving. This intimate and vital relationship plays a major role in producing the warm, punchy sound and pleasing feel that we all know and love. In a nutshell, modelling a speaker cabinet is not just a case of frequency response, but is a combination of frequency response, transient response (how a speaker reacts to the strength of how a note is played), and the all-important interaction of the amps output to the speaker's impedance curve. In addition, other vitally important factors that have to be taken into account when modelling a cabinet are the actual physical dimensions of the enclosure (cabinet), the unique tonality of said enclosure (which will be affected by both the type and thickness of the wood it is made of) and whether it boasts an open, semi-open or closed-back design. Special circuitry and unique modelling technology ensures that all of these factors are well taken care of in the cabinet models built into your ToneLab LE.

### 1. TWEED 1X8 (TWD 1X8)

The 8-inch 3.2-ohm Alnico speaker in this cabinet is built into a simple, open-backed amp with a 6V6 output valve.

### 2. TWEED 1X12 (TWD 1X12)

This speaker is the other half of our Tweed 1x12 Amp. As the name suggests it is a single 12" speaker, which uses a revered Alnico magnet.

### 3. TWEED 4X10 (TWD 4X10)

Keeping with Alnico magnet speakers, this cabinet is open backed and uses four 10" 8 Ohm speakers, wired in parallel for a total of 2 Ohms impedance.

### 4. BLACK 2X10 (BLK 2X10)

These speakers are based on an open backed 2x10" ceramic magnet 35 Watt combo.

### 5. BLACK 2X12 (BLK 2X12)

This speaker system features two 12" Ceramic magnet speakers. They are 8 Ohm units wired in parallel for a 4 Ohm total load.

Amp/Effect

AMP TYPE

CABINET TYPE

---

## 6. VOX AC15 (AC15)

This is a 1x12" open backed combo using the famed VOX Blue Alnico speaker, manufactured by Celestion in Ipswich, England.

## 7. VOX AC30 (AC30)

These original 2x12" VOX Blue Alnicos, are wired in series for 16 Ohms, and add even more of that great VOX tone.

## 8. VOX AD120VTX (AD120VTX)

This is a closed back cabinet containing two 12 inch custom-designed Celestion speakers with Neodymium magnets.

## 9. UK H30 4X12 (UK H30)

This heavy-duty cabinet with 30 Watt speakers, from the late '60s is made by the same famous UK amp company as the UK T75 4x12.

## 10. UK T75 4X12 (UK T75)

This 4x12" closed-back cabinet is loaded with modern, 75 Watt British speakers.

## 11. US V30 4X12 (US V30)

This black beast of a cabinet uses four UK made "Vintage" named speakers and is known for it's deep bass and high end detail.

## WHAT GOES WITH WHAT?

Basically, with your ToneLab LE you can mix any amp model to any cabinet model, and create many varied tones. But to give you a starting point, here is a listing of historically correct matches:

<b>AMP MODEL</b>	<b>HISTORICALLY CORRECT CABINET MODEL</b>
TWEED 1x12	TWEED 1x12
TWEED 4x10	TWEED 4x10
BLACK 2X12	BLACK 2x12
AC15	VOX AC15
AC15TB	VOX AC15
AC30	VOX AC30
AC30TB	VOX AC30
UK BLUES	UK H30
UK 68P	UK H30
UK 80's	UK T75
UK 90's	UK T75
UK MODERN	UK T75 or US V30
US HIGAIN	US V30 or UK T75
US MODERN	US V30
BOUTIQUE OD	UK H30 is a good choice
BOUTIQUE CLN	UK H30 is a good choice

## SOME RECOMMENDATIONS

As some of the manufacturers of the original amps that we modelled also used similar amps with different speaker configurations to make other models, so can you with your ToneLab LE to approximate these other amps. For instance:

<b>Amp Model</b>	<b>Cabinet Model</b>	<b>Equivalent Model</b>
BLACK 2x12	BLACK 2x10	Blackface Vibrolux type combo
BLACK 2x12	TWEED 4x10	Blackface Super type combo
TWEED 1x12	BLACK 2x10	Tweed Super type combo
UK BLUES	VOX AC30	Early BluesBreaker type combo
VOX AC15	VOX AC30	VOX AC15 Supertwin

Please note that these amps will be approximations only as original power ratings, output transformers and speaker manufacturer and types, might have been different in the original products. Due to the flexibility of your ToneLab LE, mixing and matching all of the amp and cabinet models can be done with the turn of a switch, without any risk of blowing the speakers up. Something that cannot be done in real life (unfortunately!). This capability can lead to some very interesting combinations, some useful, perhaps some not, but only you can decide what is useful to you, as



---

your tone requirements are unique. Please feel free to explore all combinations of amps and cabinets. That is the beauty of ToneLab LE.

**NOTE:** Proceed with caution, since ToneLab LE or your speakers may be damaged if you misuse the unit. A seemingly endless number of combinations of the amp and cabinet models is available. Try out many combinations until you find your “soul mate” sound! There are no rules regarding the combination of amp and cabinet models. Just use your own “free” and “creative” mind to seek out your own sonic cosmos!

**NOTE:** Product names appearing in this manual are trademarks of their respective owners, which are not associated or affiliated with VOX in any way. (except for VOX of course!!) Names and descriptions of these products are provided only for the purpose of identifying specific products that were studied by VOX in the course of developing this product.

Amp/Effect

CABINET  
TYPE

## C. PEDAL EFFECTS

The pedal effects are placed in front of the amp.

(\*): This indicates a parameter that you can control from an expression pedal.

▶ ○ PEDAL	DRIVE	LEVEL	TONE	MANUAL	TYPE	ORDER
● AMP	● GAIN	● VR GAIN	● TREBLE	● MIDDLE	● BASS	● CH VOLUME
○ CAB-OPTION	CABINET		PRESENCE	NR		PROG LVL
● MODULATION	SPEED	DEPTH	RESONANCE	MANUAL	OPTION	MIX
○ DELAY	TIME	FEEDBACK	TONE	DUCKING	OPTION	MIX
● REVERB	TIME	LO DAMP	HI DAMP	PRE DELAY		MIX
COMP	SENS	LEVEL	----	----	----	----
	1.0~10.0	0.0~10.0	----	----	----	----
ACOUSTIC	BODY	BASS	TREBLE	----	TYPE	----
	0.0~10.0	1.0~10.0	1.0~10.0	----	1/2/3/4	----
VOX WAH	----	CLOSE	OPEN	MANUAL	TYPE	ORDER
	----	1.0~10.0	1.0~10.0	1.0~10.0	847/848	PrE/PoS
U-VIBE	SPEED	DEPTH	MIX	----	----	----
	1.00~10.00	0.0~10.0	0.0~10.0	----	----	----
BLK/ORG PHASE	SPEED	DEPTH	RESO	MANUAL	TYPE	ORDER
	0.100~10.00	0.0~10.0	0.0~10.0	1.0~10.0	bL/Or1/Or2	PrE/PoS
OCTAVE	DIRECT	1OCTAVE	2OCTAVE	----	----	----
	0.0~10.0	0.0~10.0	0.0~10.0	----	----	----
RING MODULATOR	DIRECT	EFFECT	FILTER	MANUAL	----	----
	0.0~10.0	0.0~10.0	1.0~10.0	0.0~10.0	----	----
TREBLE BOOST	DRIVE	LEVEL	TONE	----	----	----
	1.0~10.0	0.0~10.0	1.0~10.0	----	----	----
TUBE OD	DRIVE	LEVEL	TONE	----	----	----
	1.0~10.0	0.0~10.0	1.0~10.0	----	----	----
SUPER OD	DRIVE	LEVEL	TONE	----	----	----
	1.0~10.0	0.0~10.0	1.0~10.0	----	----	----
BOUTIQUE	DRIVE	LEVEL	TONE	----	----	----
	1.0~10.0	0.0~10.0	1.0~10.0	----	----	----
FAT DIST	DRIVE	LEVEL	TONE	----	----	----
	1.0~10.0	0.0~10.0	1.0~10.0	----	----	----
ORANGE DIST	DRIVE	LEVEL	TONE	----	----	----
	1.0~10.0	0.0~10.0	1.0~10.0	----	----	----
METAL DIST	DRIVE	LEVEL	TONE	MIDDLE	BASS	----
	1.0~10.0	0.0~10.0	1.0~10.0	0.0~10.0	0.0~10.0	----
FUZZ	DRIVE	LEVEL	TREBLE	----	----	----
	1.0~10.0	0.0~10.0	0.0~10.0	----	----	----
OCTAFUZZ	DRIVE	LEVEL	TONE	----	----	----
	1.0~10.0	0.0~10.0	1.0~10.0	----	----	----

### 1. COMP

Gotta play a clean passage that needs to be nice, smooth and even? Need a hair more sustain on a lead line? Then, look no further; COMP is the pedal for you. Modelled on a compressor pedal that is hugely popular due to the percussive clean sound it can produce — making it perfect for '80s and '90s pop and funk rhythm work.

It can also add a singing, mellow sustain to lead lines — clean or dirty.

[1] "SENS"..... 1.0...10.0

\* Adjusts the sensitivity of the compressor (i.e. when its "smoothing" effect kicks in). The amount of compression/sustain will increase the more you turn this control up.

[2] "LEVEL" ..... 0.0...10.0

\* Adjusts the output level.

## 2. ACOUSTIC

Wanna go “unplugged” without the hassle of switching guitars and amps? Enter the acoustic guitar simulator — a clever effect that magically converts an electric guitar’s sound into that of an acoustic. It works best with a single coil (read: low output) pickup in the neck position, especially when paired with the BLACK 2x12 amp model.

- [1] "BODY" ..... 0.0...10.0  
\* Adjusts the resonance of the body selected via the TYPE parameter.
- [2] "BASS" ..... 1.0...10.0  
\* Adjusts the bass.
- [3] "TREBLE" ..... 1.0...10.0  
\* Adjusts the treble.
- [5] "TYPE" ..... 1...4  
Selects the type of body.
  - 1: M-SMALL Small-size, old body suitable for delicate arpeggio technique.
  - 2: G-SMALL Small-size body that features a unique mid range loved by country blues players.
  - 3: T-LARGE Large-size body that features a sophisticated sound suitable for pop music.
  - 4: RESO Body suitable for a resonator guitar for playing slide.

## 3. VOX WAH

This effect is modeled on two legendary VOX wah pedals; the V847 and the V848 Clyde McCoy model. Thanks to their unique “throaty” tone, these are the only wah pedals many professionals will consider stepping on. When used wisely, this pedal can either make your guitar cry like a baby or howl like a man possessed!

- [2] "CLOSE" ..... 1.0...10.0  
Adjusts the tone when the wah pedal is closed.
- [3] "OPEN" ..... 1.0...10.0  
Adjusts the tone when the wah pedal is open.
- [4] "MANUAL" ..... 1.0...10.0  
\* Adjusts the openness (position) of the wah.
- [5] "TYPE" ..... 847, 848  
Selects either V847 or V848 Clyde McCoy model as the wah type
- [6] "ORDER" ..... PrE(PRE), PoS(POST)  
Selects the connection order. PRE/POST connects the wah before/after the Amp Model.

### USEFUL TONE HINT:

A great tonal trick that’s employed by many guitarists, including some who are household names, is to find a “sweet spot” within the range of their Wah pedal and then leave it there. This is often called *stuck-Wah* (imagine that!) and, when used tastefully, can be very effective as it produces a very distinctive sound that will cut through any mix. You can dial in a stuck-Wah “sweet spot” with your TONE control in a heart-beat. Try it, it’s cool...

## 4. U-VIBE

Modeled on the famous phase/vibrato pedal effect unit. This effect simulates a rotating speaker and produces a wonderfully seductive and “watery” tone. Interestingly enough, the guy responsible for this great pedal is also responsible for the birth of the remarkable Valve Reactor Technology used in the power amp of your ToneLab LE.

- [1] "SPEED" ..... 1.00...10.00 [Hz]  
\* Adjusts the speed of the Uni-Vibe effect.
- [2] "DEPTH" ..... 0.0...10.0  
\* Adjusts the depth of the Uni-Vibe effect.
- [3] "MIX" ..... 0.0...10.0  
Adjusts the mixture of direct sound and vibrato.

**HINT:** If you set up Speed to be controlled by an expression pedal, you’ll be able to control the vibrato speed just like on a phase/vibrato pedal effect unit.

## 5. BLK/ORG PHASE (B/O PHAS)

This models three models of phaser; a wide-range four-stage phaser that was made in Denmark and packaged in a black box, a popular four-stage phaser that came in a banana-colored box, and a mild-sounding ten-stage phaser that was likewise banana-colored. Use the TYPE knob to select the model.

- [1] "SPEED" ..... 0.100...10.00 [Hz]  
\* Adjusts the modulation speed.
- [2] "DEPTH" ..... 0.0...10.0  
\* Adjusts the modulation depth.
- [3] "RESO" ..... 0.0...10.0  
\* Adjusts the amount of resonance.
- [4] "MANUAL" ..... 1.0...10.0  
\* Adjusts the center frequency of the sweep.  
MANUAL has no effect if DEPTH is set to 10.
- [5] "TYPE" ..... bL, Or1, Or2  
Selects the type of phaser.
  - bL: Danish four-stage phaser with a wide range.
  - Or1: Popular four-stage phaser in a banana-colored box.
  - Or2: Sophisticated-sounding ten-stage phaser in a banana-colored box.
- [6] "ORDER" ..... PrE (PRE), PoS (POST)  
Selects the connection order. PRE/POST places the effect before or after the AMP MODEL.

## 6. OCTAVE

This effect generates a note one or two octaves lower than the one you’re playing, adding thickness and “weight” to single note lines.

- [1] "DIRECT" ..... 0.0...10.0  
\* Adjusts the level of the original note.
- [2] "1OCTAVE" ..... 0.0...10.0  
\* Adjusts the mix level of the note one octave below.
- [3] "2OCTAVE" ..... 0.0...10.0  
\* Adjusts the mix level of the note two octaves below.

---

**WARNING!**

Like all pedals of this type, OCTAVE *only* works with single notes...chords confuse the heck out of it! NOT a fault — that's just the way these pedals operate.

## 7. RING MODULATOR (RING MOD)

A ring modulator is an effect that uses an oscillator to generate a sine wave which is then multiplied with the signal from your guitar to produce harmonics above and below the frequencies originally produced by your guitar. This creates complex and unpredictable pitches. A filter is built into the output of this effect to let you extract just the lower frequencies if desired, and this can generate low sounds that could not otherwise be produced by a guitar.

If you assign the MANUAL parameter to the expression pedal, you'll be able to control the sound in unique ways while you perform.

- [1] "DIRECT" .....0.0...10.0  
\* Adjusts the amount of original sound that is mixed in.
- [2] "EFFECT" .....0.0...10.0  
\* Adjusts the effect volume.
- [3] "FILTER" .....1.0...10.0  
\* Adjusts the filter cutoff frequency.
- [4] "MANUAL" .....0.0...10.0  
\* Adjusts the oscillator frequency.

## 8. TREBLE BOOST (TREB BST)

This pedal effect is modelled after a built-in treble booster that was designed with the VOX VBM-1 specifically in mind. It is a great way of adding "teeth" to an overdriven sound.

## 9. TUBE OD

This model is based on an overdrive pedal that's housed in a garish, "seasick green" box and is considered an all-time classic due to the wonderfully warm tones it produces.

## 10. SUPER OD

This models a yellow overdrive pedal manufactured in Japan, and is popular as a booster.

## 11. BOUTIQUE

This models an overdrive unit named after a half-human half-horse creature appearing in Greek fables. When the gain is lowered, you can use this as a booster that does not impair the original tonal character of your guitar. Raising the gain lets you use this as an overdrive that delivers a rich mid-range. The 12 o'clock position is the standard setting for tone, but feel free to adjust this aggressively.

## 12. FAT DIST

Based on a pedal named after one of the most disliked rodents to ever walk the planet! The result is a smooth distortion rich in harmonics...nasty but nice.

## 13. ORANGE DIST (OR DIST)

This models a classic distortion unit manufactured in Japan and packaged in an orange box.

- [1] "DRIVE" ..... 1.0...10.0  
\* Adjusts the amount of distortion (boost).
- [2] "LEVEL" ..... 0.0...10.0  
\* Adjusts the output level.
- [3] "TONE" ..... 1.0...10.0  
\* Adjusts the tone.

## 14. METAL DIST (MTL DIST)

This distortion model is perfect for the "metal head" in you!

- [1] "DRIVE" ..... 1.0...10.0  
\* Adjusts the amount of distortion.
- [2] "LEVEL" ..... 0.0...10.0  
\* Adjusts the output level.
- [3] "TREBLE" ..... 0.0...10.0  
\* Adjusts the high-range volume level.
- [4] "MIDDLE" ..... 0.0...10.0  
\* Adjusts the mid-range volume level.
- [5] "BASS" ..... 0.0...10.0  
\* Adjusts the low-range volume level.

## 15. FUZZ

Retro, rude "n" raw...get the picture!? The name says it all.

## 16. OCTAFUZZ

This models a legendary fuzz unit that adds a pitch one octave above the original. To get the best results, be sure to use your front pickup.

- [1] "DRIVE" ..... 1.0...10.0  
\* Adjusts the amount of distortion (boost).
- [2] "LEVEL" ..... 0.0...10.0  
\* Adjusts the output level.
- [3] "TONE" ..... 1.0...10.0  
\* Adjusts the tone.

# D. MODULATION EFFECTS

This section enables you to add a modulation effect after the cabinet. You can choose one of eleven types.

(\*): This indicates a parameter that you can control from an expression pedal.

	DRIVE	LEVEL	TOPE	MANUAL	TYPE	ORDER	
○ PEDAL	● AMP	● GAIN	● VR GAIN	● TREBLE	● MIDDLE	● BASS	● CH VOLUME
○ CAB-OPTION	CABINET	PRESENCE	NR	PROG LVL			
➔ ○ MODULATION	SPEED	DEPTH	RESONANCE	MANUAL	OPTION	MIX	
○ DELAY	TIME	FEEDBACK	TOPE	DUCKING	OPTION	MIX	
○ REVERB	TIME	LO DAMP	HI DAMP	PRE DELAY	MIX		
CLASSIC CHORUS	SPEED	DEPTH	----	MANUAL	MODE	----	
	0.100~10.00	0.0~10.0	----	1.0~10.0	1,2,3	----	
MULTI TAP CHORUS	SPEED	DEPTH	----	TIME	----	MIX	
	0.100~10.00	0.0~10.0	----	0.0~10.0	----	0.0~10.0	
CLASSIC FLANGER	SPEED	DEPTH	RESONANCE	MANUAL	OFFSET	MIX	
	0.100~10.00	0.0~10.0	0.0~10.0	1.0~10.0	0.0~10.0	0.0~10.0	
BI CHORUS	SPEED1	DEPTH	RESONANCE	SPEED2	MODE	MIX	
	0.100~10.00	0.0~10.0	0.0~10.0	0.100~10.00	S/P1/P2/P3	0.0~10.0	
DUO PHASE	SPEED1	DEPTH	RESONANCE	SPEED2	MODE	----	
	0.100~10.00	0.0~10.0	0.0~10.0	0.100~10.00	S1/S2/P1/P2/P3	----	
TEXTREM	SPEED	DEPTH	----	----	SPREAD	LEVEL	
	1.00~10.00	0.0~10.0	----	----	0.0~10.0	1.0~10.0	
ROTARY	SPEED1	DEPTH	----	SPEED2	ACCEL	----	
	0.80~10.00	0.0~10.0	----	0.80~10.0	1.0~10.0	----	
PITCH SHIFTER	PITCH	FINE	----	TRACKING	DIRECT	EFFECT	
	-24~24	-50~50	----	10~150	0.0~10.0	0.0~10.0	
MOD DELAY	SPEED	DEPTH	FEEDBACK	TIME	MODE	MIX	
	0.100~10.00	0.0~10.0	0.0~10.0	1.0~10.0	1,2,3	0.0~10.0	
FILTRON	ATTACK	DEPTH	RESONANCE	MANUAL	POLARITY	SENS	
	1.0~10.0	0.0~10.0	0.0~10.0	1.0~10.0	uP/dn	0.0~10.0	
TALK MOD	ATTACK	DEPTH	TYPE	MANUAL	POLARITY	SENS	
	1.0~10.0	0.0~10.0	A-E-O-U	1.0~10.0	uP/dn	0.0~10.0	

Amp/Effect

PEDAL

MODULATION

## 1. CLASSIC CHORUS (CL CHORS) .....

Mono In/Mono Out 1 (Mode=1,3) Mono In/Mono Out 3 (Mode=2)

This models a chorus unit that has two modes (chorus and vibrato), and is best-known for being built into a guitar amp. There's no parameter to switch between chorus and vibrato, but you can use the SPEED and DEPTH knobs to create either of these sounds, giving you an even broader range of possibilities than the original unit! The output vibrato mode allows you to create vibrato (pitch modulation) by outputting just the effect sound.

- [1] "SPEED" ..... 0.100...10.00 [Hz]  
\* Adjusts the modulation speed.
- [2] "DEPTH" .....0.0...10.0  
\* Adjusts the modulation depth.
- [4] "MANUAL" ..... 1.0...10.0

- \* Adjusts the center frequency of the sweep. If DEPTH is set to 10, MANUAL will not function.
- [5] "MODE" ..... 1, 2, 3  
Selects the output mode.
  - 1: Mono output.
  - 2: Stereo mode in which the effect is panned right, and the dry sound panned left.
  - 3: Vibrato mode, in which only the effect sound is output. Setting MANUAL to 10 will minimize the delay of the output sound.

---

## 2. MULTI TAP CHORUS (MT CHORS).....

### Stereo In/Stereo Out 1

This model features independent chorus taps for each of the left, center and right outputs, producing a feeling of depth and spaciousness.

- [1] "SPEED" ..... 0.100...10.00 [Hz]  
\* Adjusts the modulation speed.
- [2] "DEPTH" ..... 0.0...10.0  
\* Adjusts the modulation depth.
- [4] "TIME" ..... 0.0...10.0  
Adjusts the delay time.
- [6] "MIX" ..... 0.0...10.0  
\* Adjusts the mix amount of the effect.

## 3. CLASSIC FLANGER (CL FLANG).....

### Mono In/Mono Out 1

A model of a truly classic analogue flanger that "unchained" a highly influential modern guitarist who many hail as the "godfather of two handed tapping."

- [1] "SPEED" ..... 0.100...10.00 [Hz]  
\* Adjusts the modulation speed.
- [2] "DEPTH" ..... 0.0...10.0  
\* Adjusts the modulation depth.
- [3] "RESO" ..... 0.0...10.0  
\* Adjusts the amount of resonance.
- [4] "MANUAL" ..... 1.0...10.0  
\* Adjusts the center frequency of the sweep. If DEPTH is set to 10, MANUAL will not function.
- [5] "OFFSET" ..... 0.0...10.0  
Adjusts the starting position of the LFO. If you assign "FLN TRIG" to the control switch, the LFO will be reset to the starting position specified by OFFSET whenever you operate the control switch. When you defeat BYPASS, the LFO will start from the position you specify here. (p.49 Control switch settings)
- [6] "MIX" ..... 0.0...10.0  
\* Adjusts the mix amount of the effect sound.

CONTROL switch..... FLN TRIG

If you set the FLN TRIG: CONTROL switch setting to "FLN TRIG," the LFO will be reset to the position specified by OFFSET whenever you operate the switch. (p.49 Control switch settings)

## 4. BI CHORUS (BI CHORS)..... Mono In/Mono Out

### 1 (Mode=S) Stereo In/Stereo Out 1 (Mode=P1, P2, P3)

This is a chorus model unique to VOX. It provides two chorus units, CHORUS 1 and CHORUS 2, and lets you connect the two units not only in series or in parallel, but also to synchronize or de-synchronize the two LFOs. It produces a variety of tones that cover a range from wonderfully spacious sounds to bizarre flanger-like sounds with complex modulation.

- [1] "SPEED 1" ..... 0.100...10.00 [Hz]  
\* Adjusts the modulation speed of CHORUS 1.
- [2] "DEPTH" ..... 0.0...10.00  
\* Adjusts the modulation depth of CHORUS 1/2.
- [3] "RESO" ..... 0.0...10.0

\* Adjusts the amount of resonance for CHORUS 1/2.

- [4] "SPEED 2" ..... 0.100...10.00 [Hz]

\* Adjusts the modulation speed of CHORUS 2.

**NOTE:** This will not function if MODE is set to P2 or P3.

- [5] "MODE" ..... S/P1/P2/P3  
Specifies the connection and LFO for CHORUS 1/2.

S: CHORUS 1/2 are connected in series.

P1: CHORUS 1/2 are connected in parallel.

P2: CHORUS 1/2 are connected in parallel, and their LFOs are synchronized.

P3: CHORUS 1/2 are connected in parallel, and their LFOs are synchronized in opposite phase (Stereo mode).

**NOTE:** If P2 or P3 is selected, the speed is adjusted by the SPEED 1 knob.

- [6] "MIX" ..... 0.0...10.0

\* Adjusts the mix amount of the effect sound.

## 5. DUO PHASE (DUO PHAS)..... Mono In/Mono Out

### 2 (Mode=S1, S2) Stereo In/Stereo Out 2 (Mode=P1, P2, P3)

This is an amazing phaser that provides two six-stage phasers; PHASER 1 and PHASER 2. They can be connected in series (to make a pseudo-twelve-stage phaser!) or in parallel, and you can also synchronize or de-synchronize the two LFOs.

- [1] "SPEED 1" ..... 0.100...10.00 [Hz]

\* Adjusts the modulation speed of PHASER 1.

- [2] "DEPTH" ..... 0.0...10.0

\* Adjusts the modulation depth of PHASER 1/2.

- [3] "RESO" ..... 0.0...10.0

\* Adjusts the amount of resonance for PHASER 1/2.

- [4] "SPEED 2" ..... 0.100...10.00 [Hz]

\* Adjusts the modulation speed of PHASER 2.

**NOTE:** This will not function if MODE is set to S2, P2, or P3.

- [5] "MODE" ..... S1, S2, P1, P2, P3  
Specifies the connection and LFO for PHASER 1/2.

S1: PHASER 1/2 are connected in series.

S2: PHASER 1/2 are connected in series and their LFOs are synchronized to create a pseudo-twelve-stage phaser.

P1: PHASER 1/2 are connected in parallel.

P2: PHASER 1/2 are connected in parallel, and their LFOs are synchronized (Stereo mode).

P3: PHASER 1/2 are connected in parallel, and their LFOs are synchronized in opposite phase (Stereo mode).

**NOTE:** If S2, P2 or P3 is selected, the speed is adjusted by the SPEED 1 knob.

## 6. TEXTREM ..... Stereo In/Stereo Out 2

This models the popular tremolo circuit that's built into the BLACK 2x12 model. The SPREAD setting lets you produce a panning effect that spreads to left and right.

- [1] "SPEED" ..... 1.00...10.00 [Hz]  
\* Adjusts the tremolo speed.
- [2] "DEPTH" ..... 0.0...10.0  
\* Adjusts the tremolo depth.
- [5] "SPREAD" ..... 0.0...10.0  
Adjusts the left/right spaciousness.
- [6] "LEVEL" ..... 1.0...10.0  
\* Adjusts the output level.

## 7. ROTARY ..... Mono In/Stereo Out 2

This models a stereo rotary speaker. When you adjust the speed, it will take a certain amount of time for the specified speed to be reached — just like on an actual rotary speaker. This is because it takes several seconds for the motor that creates the rotation to accelerate or decelerate.

- [1] "SPEED 1" ..... 0.80...10.0 [Hz]  
\* Adjusts the rotational speed of the speaker. If you assign "ROT SPD" to the CONTROL switch, this will be the SLOW speed. This knob is effective even if you're not using the CONTROL switch. (p.49 Control switch settings)
- [2] "DEPTH" ..... 0.0...10.0  
\* Adjusts the modulation depth.
- [4] "SPEED 2" ..... 0.80...10.0 [Hz]  
\* Adjusts the rotational speed of the speaker. If you assign "ROT SPD" to the CONTROL switch, this will be the FAST speed. This knob will not function if you're not using the CONTROL switch. (p.49 Control switch settings)
- [5] "ACCEL" ..... 1.0...10.0  
\* Adjusts the time it takes for the rotational speed to change. With higher settings, the change will take more time.

CONTROL switch ..... ROT SPD  
If you select "ROT SPD" as the CONTROL switch setting, the rotation speed will alternate between SLOW/FAST (SPEED 1/SPEED 2) each time you press the CONTROL switch. This lets you control the effect just as on an actual rotary speaker. (p.49 Control switch settings)

## 8. PITCH SHIFTER (PITCH) ... Mono In/Mono Out 1

This is a pitch shifter with a range of two octaves up or down, rivaling sophisticated rack-mounted signal processors.

**PITCH SHIFTER TIPS:** If you assign the PITCH knob to an expression pedal, you can use the pedal to control the pitch change. (p.47 Using the expression pedal to control the sound)

- [1] "PITCH" ..... -24...+24  
\* Adjusts the pitch in 100-cent units.
- [2] "FINE" ..... -50...+50  
\* Adjusts the pitch in one-cent units.

- [4] "TRACKING" ..... 10...150 [ms]  
Adjusts the tracking of the pitch shifter (i.e., how closely it will follow). Shorter settings are effective if the PITCH setting is close to 0, and longer settings are effective if the PITCH setting is close to +/-24. While listening to the pitch-shifted sound, adjust this so that you do not have difficulty playing.
- [5] "DIRECT" ..... 0.0...10.0  
\* Adjusts the level of the direct sound.
- [6] "EFFECT" ..... 0.0...10.0  
\* Adjusts the level of the effect.

## 9. MOD DELAY (MOD DLY) ... Mono In/Mono Out 1

(Mode=1) Mono In/Mono Out 3 (Mode=2) Mono In/Stereo Out 1 (Mode=3)

This models an analog delay that lets you add a vibrato effect to the delayed sound. The actual unit provided 400 ms of delay time, but this simulation extends this up to 1400 ms while maintaining the same warm sound, and can also be used as a sub-delay for the DELAY section.

- [1] "SPEED" ..... 0.100...10.00 [Hz]  
\* Adjusts the modulation speed.
- [2] "DEPTH" ..... 0.0...10.0  
\* Adjusts the modulation depth.
- [3] "FEEDBACK" ..... 0.0...10.0  
\* Adjusts the amount of feedback.
- [4] "TIME" ..... 1.0...10.0  
\* Specifies the delay time.
- [5] "MODE" ..... 1,2,3  
Selects the output method.  
1: Mono output.  
2: Stereo mode with the effect sound from the right and dry sound from the left.  
3: Reverse-phase stereo mode with dry + effect in the left side and dry — effect in the right side.
- [6] "MIX" ..... 0.0...10.0  
\* Adjusts the mix amount of the effect.

## 10. FILTRON ..... Stereo In/Stereo Out 2

This is an envelope controlled filter — a filter that opens and closes according to the guitar input. By assigning the MANUAL knob to the expression pedal you can simulate Korg's TRAVELER pedal.

- [1] "ATTACK" ..... 1.0...10.0  
\* Adjusts the speed of response.
- [2] "DEPTH" ..... 0.0...10.0  
\* Adjusts the depth of the effect.
- [3] "RESO" ..... 0.0...10.0  
\* Adjusts the amount of resonance.
- [4] "MANUAL" ..... 1.0...10.0  
\* Sets the cutoff frequency. If DEPTH is set to 10, MANUAL will not function.
- [5] "POLARITY" ..... uP (UP), dn (DOWN)  
Specifies the direction of movement.
- [6] "SENS" ..... 0.0...10.0  
\* Adjusts the sensitivity of response to the guitar volume.

---

## 11. TALK MOD ..... Mono In/Mono Out 2

This is an envelope controlled talking modulator. The vocal character will change according to the input from your guitar. If you assign the MANUAL knob to the expression pedal, you'll be able to control the vowel sound from the pedal. (In this case, set the DEPTH knob to 0.)

- [1] "ATTACK" ..... 1.0...10.0  
\* Adjusts the speed of the response.
- [2] "DEPTH" ..... 0.0...10.0  
\* Adjusts the depth of operation.
- [3] "TYPE" ..... A-E...O-U  
Selects one of the following transitions between vowels.  
'A'-'E', 'A'-'I', 'A'-'O', 'A'-'U', 'E'-'I', 'E'-'O', 'E'-'U',  
'I'-'O', 'I'-'U', 'O'-'U'
- [4] "MANUAL" ..... 1.0...10.0  
\* Adjusts the vocal character. If DEPTH is set to 10, MANUAL will not function.
- [5] "POLARITY" ..... uP (UP), dn (DOWN)  
Specifies the direction of change.
- [6] "SENS" ..... 0.0...10.0  
\* Adjusts the sensitivity of response to the guitar volume.



# E. DELAY EFFECTS

Here you can make settings for a delay effect inserted after the cabinet. You can choose one of eleven types.

(\*): This indicates a parameter that you can control from the expression pedal.

	○ PEDAL	DRIVE	LEVEL	● TONE	MANUAL	TYPE	ORDER
	● AMP	● GAIN	● VR GAIN	● TREBLE	● MIDDLE	● BASS	● CH VOLUME
	○ CAB-OPTION	CABINET	PRESENCE	NR	PROG LVL		
	○ MODULATION	SPEED	DEPTH	RESONANCE	MANUAL	OPTION	MIX
➔	○ DELAY	TIME	FEEDBACK	● TONE	DUCKING	OPTION	MIX
	○ REVERB	TIME	LO DAMP	HI DAMP	PRE DELAY		MIX
ECHOPLUS		TIME	FEEDBACK	TONE	----	LODAMP	MIX
		26~2000[ms]	0.0~10.0	1.0~10.0	----	0.0~10.0	0.0~10.0
MULTIHEAD		TIME	FEEDBACK	TONE	----	MODE	MIX
		1~2000[ms]	0.0~10.0	1.0~10.0	----	1,2,3,4,5	0.0~10.0
ANALOG DELAY		TIME	FEEDBACK	TONE	----	----	MIX
		1~2000[ms]	0.0~10.0	1.0~10.0	----	----	0.0~10.0
MOD DELAY		TIME	FEEDBACK	TONE	----	SPEED	MIX
		3~2000[ms]	0.0~10.0	1.0~10.0	----	0.100~10.00[Hz]	0.0~10.0
SWEEP DELAY		TIME	FEEDBACK	TONE	----	SENS	MIX
		26~2000[ms]	0.0~10.0	1.0~10.0	----	0.0~10.0	0.0~10.0
STEREO DELAY		TIME	FEEDBACK	TONE	DUCKING	----	MIX
		1~4000[ms]	0.0~10.0	1.0~10.0	0.0~10.0	----	0.0~10.0
CROSS DELAY		TIME	FEEDBACK	TONE	DUCKING	----	MIX
		1~4000[ms]	0.0~10.0	1.0~10.0	0.0~10.0	----	0.0~10.0
2TAP DELAY		TIME	FEEDBACK	TONE	DUCKING	TAP TIME	MIX
		1~4000[ms]	0.0~10.0	1.0~10.0	0.0~10.0	0.0~10.0	0.0~10.0
RHYTHM DELAY		TIME	FEEDBACK	TONE	DUCKING	RHYTHM	MIX
		1~4000[ms]	0.0~10.0	1.0~10.0	0.0~10.0	1,2,..11	0.0~10.0
HOLD DELAY		TIME	FEEDBACK	TONE	----	----	MIX
		1~8000[ms]	0.0~10.0	1.0~10.0	----	----	0.0~10.0
REVERSE DELAY		TIME	FEEDBACK	TONE	----	----	MIX
		26~8000[ms]	0.0~10.0	1.0~10.0	----	----	0.0~10.0

Amp/Effect

MODULATION

DELAY





## 1. ECHO PLUS..... Mono In/Mono Out 1

This models one of the most respected analogue tape echo machines ever made. In the original, the "echo" is produced by a playback head and the exact "delay time" is set by varying the motor speed. Many professionals prefer these "lo-fi" units because of the warm, dark echoes they produce.

- [1] "TIME" .....26...2000 [ms]  
\* Sets the delay time.
- [2] "FEEDBACK" .....0.0...10.0  
\* Adjusts the amount of feedback.
- [3] "TONE" .....1.0...10.0  
\* Adjusts the tone of the delay.
- [5] "LODAMP" .....0.0...10.0  
\* Adjusts the amount of low-frequency attenuation.
- [6] "MIX" .....0.0...10.0  
\* Adjusts the mix amount of the delay.

## 2. MULTI HEAD (MULTI HD) Mono In/Mono Out 1

This is a model of a tape echo unit boasting three playback heads. The echo from each head has its own feedback loop, letting you create warm and complex "multi-tap" echo effects.

- [1] "TIME" ..... 1...2000 [ms]  
Sets the delay time.
- [2] "FEEDBACK" ..... 0.0...10.0  
\* Adjusts the amount of feedback.
- [3] "TONE" ..... 1.0...10.0  
\* Adjusts the tone of the delay sound.
- [5] "MODE" ..... 1, 2, 3, 4, 5  
Specifies the combination of heads that will be used.
  - 1: Conventional echo.
  - 2:  The delayed sound produces a rhythm of "ta-ta-ta (rest)."
  - 3:  The delayed sound produces a rhythm of "ta (rest) ta-ta."
  - 4:  The delayed sound produces a rhythm of "ta-ta (rest) ta."
  - 5:  The delayed sound produces a rhythm of "ta-ta-ta-ta."
- [6] "MIX" ..... 0.0...10.0  
\* Adjusts the mix amount of the delay.

## 3. ANALOG DELAY (ANALG DL) .....

Mono In/Mono Out 1

This models an analog delay that used a bucket-brigade device (BBD) instead of a tape mechanism and was known for its compactness and reliability. It is characterized by a warmly distorted sound.

- [1] "TIME" ..... 1...2000 [ms]  
\* Sets the delay time.
- [2] "FEEDBACK" ..... 0.0...10.0  
\* Adjusts the amount of feedback.
- [3] "TONE" ..... 1.0...10.0  
\* Adjusts the tone of the delay.
- [6] "MIX" ..... 0.0...10.0  
\* Adjusts the mix amount of the delay.

## 4. MOD DELAY (MOD DLY) .. Mono In/Mono Out 1

This models Korg's first digital delay, the SDD-3000. You can also use this to produce chorus or flanger-like effects by setting a short TIME and using the LFO to modulate it.

- [1] "TIME" ..... 3...2000 [ms]  
\* Sets the delay time.
- [2] "FEEDBACK" ..... 0.0...10.0  
\* Adjusts the amount of feedback.
- [3] "TONE" ..... 1.0...10.0  
\* Adjusts the tone of the delay.
- [5] "SPEED" ..... 0.100...10.00 [Hz]  
\* Adjusts the modulation speed.
- [6] "MIX" ..... 0.0...10.0  
\* Adjusts the mix amount of the delay.

## 5. SWEEP DELAY (SWEEP DL) .....

Mono In/Mono Out 1

This also models the SDD-3000. Here you can use the envelope of your guitar signal to control the DELAY TIME, and by setting a short TIME and raising the FEEDBACK you can produce a distinctive flanger effect. Even with conventional settings of TIME, you can produce unique effects that would not be possible with an LFO.

- [1] "TIME" ..... 26...2000 [ms]  
\* Sets the delay time.
- [2] "FEEDBACK" ..... 0.0...10.0  
\* Adjusts the amount of feedback.
- [3] "TONE" ..... 1.0...10.0  
\* Adjusts the tone of the delay.
- [5] "SENS" ..... 0.0...10.0  
\* Adjusts the sensitivity at which the effect responds to the volume of your guitar.
- [6] "MIX" ..... 0.0...10.0  
\* Adjusts the mix amount of the delay.

## 6. STEREO DELAY (ST DL) .. Stereo In/Stereo Out 1

This is Korg's 24-bit digital delay, the DL8000R. With the exception of the sampling frequency and wave control of the DELAY TIME, the circuit is essentially identical. Since this is a full-stereo design, it's particularly effective to place it after the output of a stereo MOD or REVERB effect.

- [1] "TIME" ..... 1...4000 [ms]  
Sets the delay time.
- [2] "FEEDBACK" ..... 0.0...10.0  
\* Adjusts the amount of feedback.
- [3] "TONE" ..... 1.0...10.0  
\* Adjusts the tone of the delay.
- [4] "DUCKING" ..... 0.0...10.0  
\* Adjusts the sensitivity at which the effect will "duck" (decrease) in response to the volume of your guitar.
- [6] "MIX" ..... 0.0...10.0  
\* Adjusts the mix amount of the delay.

**HINT:** Ducking: This automatically lowers the volume of the delay sound when you play your guitar loudly, allowing your playing to come through.

**7. CROSS DELAY (CROSS DL) .....****Stereo In/Stereo Out 3**

This is the DL8000R with settings to make the feedback cross over from L→R and R→L.

- [1] "TIME" ..... 1...4000 [ms]  
Sets the delay time.
- [2] "FEEDBACK" ..... 0.0...10.0  
\* Adjusts the amount of feedback.
- [3] "TONE" ..... 1.0...10.0  
\* Adjusts the tone of the delay.
- [4] "DUCKING" ..... 0.0...10.0  
\* Adjusts the sensitivity at which the effect will "duck" (decrease) in response to the volume of your guitar.
- [6] "MIX" ..... 0.0...10.0  
\* Adjusts the mix amount of the delay.

**8. 2TAP DELAY (2TAP DLY) .Mono In/Stereo Out 1**

This is the DL8000R with two delay taps whose DELAY TIME is skewed by 20 ms and separately assigned to L and R, turning a mono input into stereo.

- [1] "TIME" ..... 1...4000 [ms]  
Sets the delay time.
- [2] "FEEDBACK" ..... 0.0...10.0  
\* Adjusts the amount of feedback.
- [3] "TONE" ..... 1.0...10.0  
\* Adjusts the tone of the delay.
- [4] "DUCKING" ..... 0.0...10.0  
\* Adjusts the sensitivity at which the effect will "duck" (decrease) in response to the volume of your guitar.
- [5] "TAP TIME" ..... 0.0...10.0  
Adjusts the ratio of delay time of the right relative to the left.
- [6] "MIX" ..... 0.0...10.0  
\* Adjusts the mix amount of the delay.

**9. RHYTHM DELAY (RHYTHM DL).....****Mono In/Mono Out 1**

This provides a DL8000R function in which the TIME of two delay taps is automatically set according to the RHYTHM you specify.

- [1] "TIME" ..... 1...4000 [ms]  
Sets the delay time.
- [2] "FEEDBACK" ..... 0.0...10.0  
\* Adjusts the amount of feedback.
- [3] "TONE" ..... 1.0...10.0  
\* Adjusts the tone of the delay.
- [4] "DUCKING" ..... 0.0...10.0  
\* Adjusts the sensitivity at which the effect will "duck" (decrease) in response to the volume of your guitar.
- [5] "RHYTHM" ..... 1, 2, ...11  
Specifies the two-tap rhythm delay when the delay time is set to quarter-note timing. For some settings, only one tap is used.
- [6] "MIX" ..... 0.0...10.0  
\* Adjusts the mix amount of the delay.

**10. HOLD DELAY (HOLD DLY) .....****Mono In/Mono Out 1**

If you select "HOLD DLY" "HOLD DLY" will be automatically assigned to the CONTROL switch, enabling you to hold the delay sound.

- [1] "TIME" ..... 1...8000 [ms]  
Sets the delay time.
- [2] "FEEDBACK" ..... 0.0...10.0  
\* Adjusts the amount of feedback.
- [3] "TONE" ..... 1.0...10.0  
\* Adjusts the tone of the delay.
- [6] "MIX" ..... 0.0...10.0  
\* Adjusts the mix amount of the delay.

CONTROL switch: ..... HOLD DLY:

The delay sound will be held from the moment you turn the switch on.

**11. REVERSE DELAY (REVRS DL) .....****Mono In/Mono Out 1**

This is a digital delay that plays the delay sound backward. You can get some really cool results by playing long notes in a legato fashion.

- [1] "TIME" ..... 26...8000 [ms]  
Sets the delay time.
- [2] "FEEDBACK" ..... 0.0...10.0  
\* Adjusts the amount of feedback.
- [3] "TONE" ..... 1.0...10.0  
\* Adjusts the tone of the delay.
- [6] "MIX" ..... 0.0...10.0  
Adjusts the mix balance between the delay sound and direct sound. With a setting of 10 you will hear only the delay.

## F. REVERB EFFECTS

Here you can make settings for the reverb effect that is placed after the cabinet. You can choose one of eleven types.

(\*): This indicates a parameter that you can control from an expression pedal.

	○ PEDAL	DRIVE	LEVEL	TONE	MANUAL	TYPE	ORDER
	● AMP	● GAIN	● VR GAIN	● TREBLE	● MIDDLE	● BASS	● CH VOLUME
	○ CAB-OPTION	CABINET		PRESENCE	NR		PROG LVL
	● MODULATION	SPEED	DEPTH	RESONANCE	MANUAL	OPTION	MIX
	○ DELAY	TIME	FEEDBACK	TONE	DUCKING	OPTION	MIX
➔	● REVERB	TIME	LO DAMP	HI DAMP	PRE DELAY		MIX
SLAP		TIME	LO DAMP	HI DAMP	PRE DELAY	----	MIX
		1.0~10.0	0.0~10.0	0.0~10.0	0~70[ms]	----	0.0~10.0
SPRING		TIME	LO DAMP	HI DAMP	PRE DELAY	----	MIX
		1.0~10.0	0.0~10.0	0.0~10.0	0~70[ms]	----	0.0~10.0
BOUNCE		TIME	LO DAMP	HI DAMP	PRE DELAY	----	MIX
		1.0~10.0	0.0~10.0	0.0~10.0	0~70[ms]	----	0.0~10.0
PLATE		TIME	LO DAMP	HI DAMP	PRE DELAY	----	MIX
		1.0~10.0	0.0~10.0	0.0~10.0	0~70[ms]	----	0.0~10.0
GARAGE		TIME	LO DAMP	HI DAMP	PRE DELAY	----	MIX
		1.0~10.0	0.0~10.0	0.0~10.0	0~70[ms]	----	0.0~10.0
CHAMBER		TIME	LO DAMP	HI DAMP	PRE DELAY	----	MIX
		1.0~10.0	0.0~10.0	0.0~10.0	0~70[ms]	----	0.0~10.0
CANYON		TIME	LO DAMP	HI DAMP	PRE DELAY	----	MIX
		1.0~10.0	0.0~10.0	0.0~10.0	0~70[ms]	----	0.0~10.0
ROOM		TIME	LO DAMP	HI DAMP	PRE DELAY	----	MIX
		1.0~10.0	0.0~10.0	0.0~10.0	0~70[ms]	----	0.0~10.0
STUDIO		TIME	LO DAMP	HI DAMP	PRE DELAY	----	MIX
		1.0~10.0	0.0~10.0	0.0~10.0	0~70[ms]	----	0.0~10.0
HALL		TIME	LO DAMP	HI DAMP	PRE DELAY	----	MIX
		1.0~10.0	0.0~10.0	0.0~10.0	0~70[ms]	----	0.0~10.0
ARENA		TIME	LO DAMP	HI DAMP	PRE DELAY	----	MIX
		1.0~10.0	0.0~10.0	0.0~10.0	0~70[ms]	----	0.0~10.0

**1. SLAP** .....Mono In/Stereo Out 1  
This models a tiny room with a very short reverb time.

**2. SPRING** .....Mono In/Stereo Out 1  
This models the spring reverb system used in guitar amps — ideal for surf music!

**3. BOUNCE** .....Mono In/Stereo Out 1  
This models a spring reverb that produces a higher-density reverberation.

**4. PLATE** .....Mono In/Stereo Out 1  
This models a type of reverb unit that works by vibrating a metal plate instead of a spring. It is adjusted to a fairly short reverb time. This rever-

beration is characterized by a rapid attack, and is suitable for percussive playing.

**5. GARAGE** .....Mono In/Stereo Out 1  
This models a garage that produces a high-density reverberation.

**6. CHAMBER** .....Mono In/Stereo Out 1  
In years past, recording studios often used a room (echo chamber) that was specially designed to produce reverberation and contained a speaker and mic used to record reverberation. This model simulates a mild-sounding echo chamber.

**7. CANYON** .....Mono In/Stereo Out 1

This models the reverberation of a canyon.

**8. ROOM** .....Mono In/Stereo Out 1

This models the reverberation of a typical room, with numerous early reflections.

**9. STUDIO** .....Mono In/Stereo Out 1

This models the reverberation of a large room.

**10. HALL** .....Mono In/Stereo Out 1

This models the reverberation of a concert hall with numerous echoes.

**11. ARENA** .....Mono In/Stereo Out 1

This models an arena with smooth and dense reverberation.

- [1] "TIME" ..... 1.0...10.0  
\* Sets the reverb time, which will differ depending on the reverb type.
- [2] "LO DAMP" ..... 1.0...10.0  
\* Adjusts the attenuation of the low-frequency range.
- [3] "HI DAMP" ..... 1.0...10.0  
\* Adjusts the attenuation of the high-frequency range.
- [4] "PRE DLY" ..... 1.0...70[ms]  
Sets the initial delay before the reverberation begins. By adjusting this setting you can clarify the definition of the original sound.
- [6] "MIX" ..... 1.0...10.0  
\* Adjusts the mix amount of the reverb.

**BLOCK DIAGRAM**

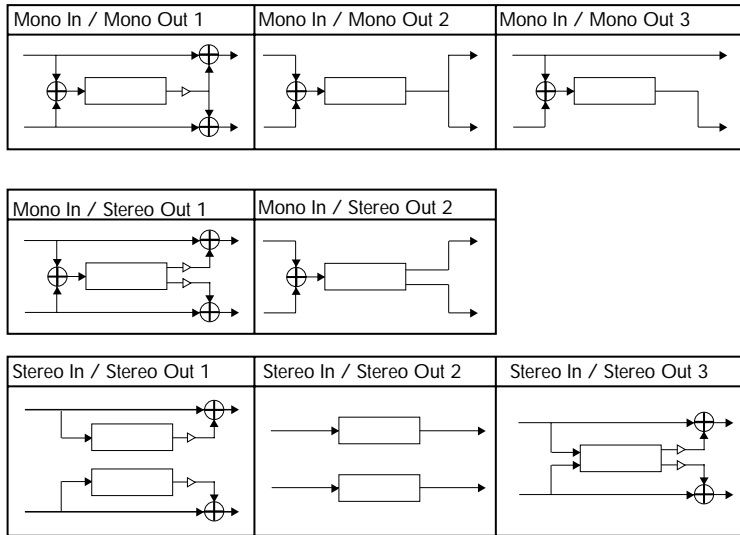

Amp/Effect

REVERB

# Tuner (Bypass, Mute)

For your convenience, ToneLab LE contains an automatic chromatic tuner. The frequency of the middle “A” reference pitch can be adjusted (calibrated) over a range of 438 Hz–445 Hz.

## TUNING PROCEDURE

**HINT:** Pressing the EXIT/TUNE button while the name display is indicating a program name will activate the tuner.

1. Make sure that ToneLab LE is in Program Select mode, and that the BANK UP and DOWN switch LEDs are turned off. If the BANK UP switch LED is lit green, ToneLab LE is in Effect On/Off mode. In this case, press the BANK UP switch to enter Program Select mode.

2. Press and hold the pedal of the currently-selected program (the pedal LED is lit red) for about 0.5 seconds. All effects will be bypassed, and the Auto Chromatic Tuner will operate.

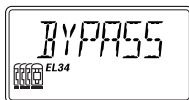

If you are playing a live performance and want to tune without being heard by the audience, select Silent Tuning mode as follows before you tune your guitar.

Hold down the pedal of the currently-selected program for about 1.5 seconds to enter Silent Tuning mode. This mode enables you to tune your guitar with the output muted.

3. When you play a string on your guitar, the nearest pitch will appear in the bank display, and a meter will appear in the name display. The note names are displayed as follows.

C	C#	D	D#	E	F
C	C#	d	d#	E	F
F#	G	G#	A	A#	B
F#	G	G#	A	A#	B

4. Watch the meter, and tune your guitar.

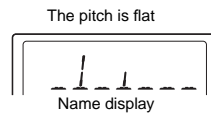
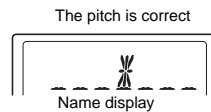
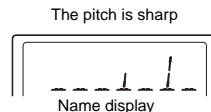

5. When you're finished tuning, press any program select switch again to return to Program Select mode.

**HINT:** If you have cancelled Tuning mode by pressing a program select switch that is different from the one you pressed to start the tuner, the program will be also changed.

## CALIBRATING THE TUNER

When you switch ToneLab LE on, the built-in tuner is automatically calibrated to A=440 Hz (a.k.a. “concert pitch”). If desired, you can recalibrate the tuner in the range of A = 438 Hz–445 Hz.

- While the tuner is active, the value display (3.3) shows the frequency of the reference pitch. You can use the ▲, ▼ buttons to adjust (calibrate) this in the range of 438 Hz–445 Hz.

**NOTE:** If you've recalibrated the tuner, remember that the setting will be automatically reset to 440 Hz the next time you turn ToneLab LE on.

# Using the expression pedals

## EXPRESSION PEDAL SETTINGS

ToneLab LE provides two expression pedals that you can use to control not only wah or volume, but a wide variety of effect parameters. For each program, you can specify which effect will be controlled, and how.

**HINT:** If you assigned a parameter to an expression pedal, operating the pedal has the same result as using the knob to edit the program. When you write the program, it will be written with the sound as currently specified by the position of the pedal. However if the expression pedal target is “--OFF--,” “VOLUME,” “M/PITCH,” “D/INPUT,” or “R/INPUT,” the program parameter will not be edited by the pedal.

### EXPRESSION TARGET QUICK ASSIGN

Here’s a very easy and convenient way to set the expression target.

As an example, use the MODULATION selector to choose PITCH SHIFTER. So that the effect will be easy to hear, we’ll initialize the PITCH SHIFTER. If PITCH SHIFTER is already selected, turn the selector to choose a different effect, and then re-select PITCH SHIFTER.

1. When you’re editing PITCH SHIFTER, turn value knob 1 or use the ◀, ▶ buttons to make the name display show PITCH; the EXP-CTL-CHAIN button will light. If in this state you press and hold (for one second) the EXP-CTL-CHAIN button, the name display will indicate COMPLETE. The PITCH parameter has now been assigned to the expression pedal, letting you control the amount of PITCH SHIFT. If you want to make more detailed settings, you can press the EXP-CTL-CHAIN button and set the minimum value (“EXP MIN,” value knob 2) and maximum value (“EXP MAX,” value knob 3) of the target range.

**NOTE:** If you change the effect type of a parameter that is assigned to an expression target (i.e., to be controlled by one of the expression pedals), the target will be initialized to a setting of “--OFF--”. (However, “A/\*\*\*\*\*”, “D/INPUT”, and “R/INPUT” are exceptions.)

**HINT:** If you’ve set the PEDAL effect type to “VOX WAH,” the “P/MANUAL” (wah position) will automatically

be assigned to expression. If you then set the PEDAL effect to a different type without making any further settings, the Target, Min, and Max settings will automatically return to their former settings. (However in the case of “P/\*\*\*\*\*”, it will be initialized to “--OFF--” instead of returning to its former setting.)

**NOTE:** When you change the expression target, the MIN and MAX values will be initialized.

### SETTING THE EXPRESSION TARGET

Here are the items you can set.

When you’ve pressed the EXP-CTL-CHAIN button to make it blink, you’ll be able to set the following items by turning value knobs 1–3.

“*/#####”: EXP expression target (value display indicates EP)	Value knob 1
“EXP MIN:” EXP (expression pedal) target range (minimum value)	Value knob 2
“EXP MAX:” EXP (expression pedal) target range (maximum value)	Value knob 3

**NOTE:** You can set the above items individually for each program. If you switch to a different program or turn off the power without saving, any changes you’ve made will be lost.

Using the same example we described earlier in Quick Assign, here’s how to assign the expression pedal to control the PITCH parameter of the PITCH SHIFTER modulation effect.

1. Use the MODULATION selector to select PITCH SHIFTER. If PITCH SHIFTER is already selected, turn the selector to choose a different effect, and then re-select PITCH SHIFTER.

**NOTE:** If you change the effect type of a parameter that is assigned to an expression target, the target will be initialized to a setting of “--OFF--”. (However, “A/\*\*\*\*\*”, “D/INPUT”, and “R/INPUT” are exceptions.)

**HINT:** If you’ve set the PEDAL effect type to “VOX WAH,” the “P/MANUAL” (wah position) will automatically be assigned to expression. If you then set the PEDAL effect to a different type without making any further settings, the target setting will also automatically return to the former setting.

2. Press the EXP-CTL-CHAIN button to make it blink.
3. Press the ◀ and ▶ buttons or turn value knob 1 until the value display reads “EP”
4. Use the ▲, ▼ buttons or turn value knob 1 to make the name display read “M/PITCH”. The PITCH parameter of the PITCH SHIFTER effect has now been assigned to expression pedal.

**NOTE:** Unlike other parameters, the PITCH parameter is not edited (while the tone is affected) when you control it from an expression pedal.

This is so that the pitch will change smoothly even when MIN and MAX are set to values that are close to each other (i.e., when you made settings so that the pedal produces only a small amount of pitch change).

**NOTE:** Nothing will be controlled if the target effect is "OFF."

The expression pedal target is indicated as follows.

"\*/##### \*: Target category, #####: Target parameter

• **Examples**

"--OFF--"	--- OFF	(controls nothing)
"VOLUME"	---	Volume pedal
"P/DIRECT"	--- (*: P (pedal))	DIRECT (mix amount of original sound) for a pedal effect (e.g., OCTAVE)
"M/SPEED"	--- (*: M (modulation))	SPEED of a modulation effect
"D/INPUT"	--- (*: D (delay))	Input level of a delay effect
"R/MIX"	--- (*: R (reverb))	MIX (mix amount of reverb) of a reverb effect

In addition to the examples we've shown here, a wide variety of expression targets provided for each effect model can be freely assigned to the expression pedal.

If desired, you can make more detailed settings.

**NOTE:** For "--OFF--," "VOLUME," "M/PITCH," "D/INPUT" and "R/INPUT," operating the expression pedal changes the tone, but does not edit the parameter.

5. Turn value knob 2 to make the name display read "EXP MIN." Here you can specify the PITCH value for when the pedal is at the minimum position. Use value knob 2 or the ▲, ▼ buttons to adjust the setting.

6. Turn value knob 3 to make the name display read "EXP MAX." Here you can specify the PITCH value for when the pedal is at the maximum position. Use value knob 3 or the ▲, ▼ buttons to adjust the setting.

When you operate the expression pedal, the target parameter will change within the range you specified here.

**NOTE:** When you change the expression target, the MIN and MAX values will be initialized.

7. Press the EXIT/TUNE button to return to the mode you were in.

**NOTE:** The changes you make will not be preserved in internal memory unless you store the program.

## EXPRESSION PEDAL CONTROL INITIALIZATION SETTINGS (EXPINIT)

1. Press the GLOBAL button, then the ► button.

The "INIT" setting screen will appear.

"EXP INIT" lets you specify whether the control data for an expression pedal (i.e., the position of the pedal) will be maintained when you switch programs.

2. Use the ▲, ▼ buttons or rotate value knob 6 to change the setting.

If this is turned "OFF": The instant you switch programs, the parameter that is specified as the expression target will change according to the current position of the pedal.

If this is turned "ON": The parameter will be initialized to the same setting as when the program was saved (i.e., the control data will be initialized).

Press the EXIT/TUNE button to exit this editing operation and return to the previous mode.

**NOTE:** The "EXP INIT" setting is not saved in a program. This setting applies to all programs globally, and the setting is saved automatically.

**NOTE:** If the expression pedal target is "VOLUME," "D/INPUT," or "R/INPUT," the tone will be changed according to the current position of the pedal, regardless of the "EXP INIT" setting.



## CONTROL SWITCH SETTINGS

You can make the following control switch settings independently for each program.

Press the EXP-CTL-CHAIN button to make it blink, and use value knob 4 to select the effect you want to control.

### SWITCHING EACH EFFECT ON/OFF

- “I/ONOFF” External effect insertion on/off
- “P/ONOFF” Pedal effect on/off
- “A/ONOFF” Amp model on/off
- “AC/ONOFF” Links the Amp model on/off status to the Cabinet model on/off
- “C/ONOFF” Cabinet effect on/off
- “M/ONOFF” Modulation effect on/off
- “D/ONOFF” Delay effect on/off
- “R/ONOFF” Reverb effect on/off

**NOTE:** The CONTROL switch LEDs indicate the on/off status.

### USING TAP TEMPO TO SET A PARAMETER

- “MOD TAP” Use TAP TEMPO to set the SPEED parameter of the modulation effect
- “DLY TAP” Use TAP TEMPO to set the TIME parameter of the delay effect

**NOTE:** The CONTROL switch LED will blink at the tempo you specify.

### EFFECT CONTROL

- “FLN TRIG” LFO START TRIGGER of the CLASSIC FLANGER effect
- “ROT SPD” SPEED SW of the ROTARY effect
- “HOLD DLY” HOLD of the HOLD DELAY effect

**NOTE:** If you haven't selected an applicable effect, nothing will be controlled.

1. Press the EXP-CTL-CHAIN button to make it blink.
2. To display the control target, press the ► button four times.
3. To select the control target, use the ▲, ▼ buttons or turn value knob 4.
4. If you've selected MOD TAP or DLY TAP, press the ► button or turn value knob 5 to

make the name display read “FACTOR”.

Here you can specify the proportion of SPEED or TIME in relation to the interval of your taps. For example if you set DLY TAP as the target, and FACTOR to “1-4,” the delay time will be set to 1/4th of the duration between taps.

5. Press the EXIT/TUNE button to return to the mode you were in.

### FACTOR VALUE KNOB 5 SETTING

If the MODULATION effect's SPEED parameter or the DELAY effect's TIME parameter are assigned to a control switch, you can set the MODULATION effect's LFO SPEED or the DELAY effect's DELAY TIME by the interval at which you press the control switch twice. When you do so, the interval at which you actually press the pedal will be applied to the parameter at a “factor” (i.e., multiple) of 1/6, 1/4, 1/3, 1/2, 2/3, 3/4, 1, 4/3, 3/2, 2, 3, or 4, according to the setting of the FACTOR parameter (value knob 5).

**NOTE:** The maximum spacing of your taps can be no more than ten seconds.

**NOTE:** If you've assigned a parameter other than MOD TAP or DLY TAP, the FACTOR setting does nothing.

**NOTE:** If you change the control switch setting, the FACTOR parameter is reset to “1.”

---

## ADJUSTING THE SENSITIVITY OF THE PEDAL

If you notice that advancing the ToneLab LE's expression pedal does not reach the full effect or volume even when the Min and Max parameters are set to the minimum and maximum settings, or that returning the expression pedal does not reach the minimum effect or volume, you will need to perform the following adjustment so that ToneLab LE's expression pedal will be able to reach its full range of operation.

**NOTE:** When adjusting the sensitivity, you should use your hand to operate the pedal. Accurate adjustment may not be possible if you use your foot to operate it.

### EXPRESSION PEDAL

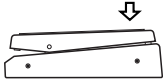
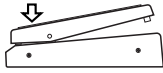
1. Turn the power OFF.
2. While holding down the EXP-CTL-CHAIN button and the ▲ button, turn the power on. The name display indicates EXP MAX.
3. Slowly advance the expression pedal away from yourself (pedal forward), and take your hand off the pedal when it stops.
4. Press the GLOBAL button. The name display indicates EXP MIN.
5. Slowly return the expression pedal toward yourself (pedal back), and take your hand off the pedal when it stops.

**NOTE:** If you decide to cancel the calibration procedure, press the EXIT/TUNE button.

6. Press the GLOBAL button.  
The name display will indicate COMPLETE for one second, and then ToneLab LE will return to normal operation.  
If the sensitivity could not be adjusted correctly, the name display will indicate ERROR, and will then indicate EXP MAX. Repeat the procedure from step 3.

**NOTE:** If you are still unable to adjust the sensitivity after repeated attempts, it is possible that ToneLab LE has malfunctioned. Please contact your dealer or Vox authorized service center.

# Control via MIDI

**M**IDI stands for Musical Instrument Digital Interface, and is a world-wide standard for exchanging various types of musical data between electronic musical instruments and computers. When MIDI cables are used to connect two or more MIDI devices, performance data can be exchanged between the devices, even if they were made by different manufacturers.

ToneLab LE can use MIDI to communicate in the following ways with another MIDI device. You can:

- Operate ToneLab LE to switch programs on an external MIDI device, or switch ToneLab LE programs from an external MIDI device. →“Program change”
- Operate a connected optional foot controller to control an external MIDI device, or use an external MIDI device to control ToneLab LE's volume or effects. →“Control change”
- Use Sound Editor to edit parameters. →“Parameter change”
- Backup (save) and restore (load) ToneLab LE program data. →“Backing up and restoring program data”

**NOTE:** In order to do the above things, you need to use a MIDI cable to connect ToneLab LE and your external MIDI device, and set the MIDI channels appropriately. →“Connecting a MIDI device or computer,” “Setting the MIDI channel”

**NOTE:** When you change the settings described in this section, they will be saved automatically. When you have finished making settings, simply press the EXIT/TUNE button (4.8) to return to the mode you were in.

**NOTE:** If your external MIDI device does not recognize certain types of MIDI messages, those messages cannot be used for control. Check the “MIDI implementation chart” of ToneLab LE and of your external MIDI device.

## CONNECTING A MIDI DEVICE OR COMPUTER

If you want to control an external MIDI device from ToneLab LE, connect a MIDI cable from ToneLab LE's MIDI OUT jack to the MIDI IN jack of your external MIDI device.

If you want to control ToneLab LE from a MIDI sequencer or other external MIDI device, connect a MIDI cable from your external MIDI device's MIDI OUT jack to ToneLab LE's MIDI IN jack.

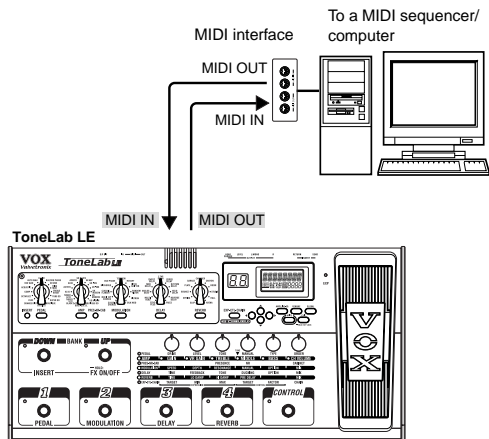

When you connect ToneLab LE with a MIDI sequencer or sound editor, data will normally be sent in both directions, so you will need to connect MIDI cables from ToneLab LE's MIDI OUT jack to the external MIDI device's MIDI IN jack, and from the external MIDI device's MIDI OUT jack to ToneLab LE's MIDI IN jack.

**NOTE:** You will need a MIDI interface in order to connect your computer with ToneLab LE. Some USB-MIDI interface devices may not be able to transmit/receive the ToneLab LE's MIDI exclusive messages.

## SETTING THE MIDI MESSAGE

### SETTING THE MIDI CHANNEL (GLOBAL “MIDI CH”)

In order to exchange data with an external MIDI device, ToneLab LE's MIDI channel must match the MIDI channel of your external MIDI device. Here's how to set the MIDI channel.

1. Press the GLOBAL button (4.6).
2. The name display (3.1) will show “MIDI CH.” If a different parameter is selected, press the ◀, ▶ buttons (4.3) to change the display.
3. Use the value knob 6 (2.2) or the ▲, ▼ buttons (4.2) to set ToneLab LE's MIDI channel.
4. Set the MIDI channel of your connected external MIDI device.

For details on how to set the MIDI channel of your external MIDI device, refer to its owner's manual.

### PROGRAM CHANGE (GLOBAL “PCHG OUT”)

When you switch programs on ToneLab LE, a program change message is transmitted from the MIDI OUT jack, causing an external MIDI device

---

to switch programs. Similarly, when ToneLab LE receives a program change message, its program will switch automatically. Here's how you can specify whether a program change message will be transmitted from the MIDI OUT jack when you switch programs on ToneLab LE.

**NOTE:** Program change numbers not used by ToneLab LE will be ignored. For details on the range of program change numbers used by ToneLab LE, refer to End of this manual.

1. Press the GLOBAL button (4.6).
2. Press the ◀, ▶ buttons (4.3) to make the name display (3.1) show "PCHG OUT."
3. Specify whether program change messages will be transmitted. Use value knob 6 (2.2) or the ▲, ▼ buttons (4.2) to make the desired setting.

"OFF": Program change messages will not be transmitted.

"On": Program change messages will be transmitted.

## CONTROL CHANGE (GLOBAL "CCHG I/O")

When you operate the EXPRESSION pedal, or Control switch of the ToneLab LE, control change messages will be transmitted. This means that functions for the corresponding control change numbers on an external MIDI device can be controlled in realtime.

Similarly, when ToneLab LE receives control change messages from an external MIDI device, it will be controlled in the same way as if its own foot controller were operated.

For a list of the functions that can be controlled from an external MIDI device, refer to step 4.

Here you can specify whether ToneLab LE will transmit and receive control change messages.

1. Press the GLOBAL button (4.6).
2. Press the ◀, ▶ buttons (4.3) to make the name display (3.1) read "CCHG I/O."
3. Specify whether all control change messages will be transmitted or received. Use value knob 6 (2.2) or the ▲, ▼ buttons (4.2) to make your choice.

"On" allows transmitting and receiving.

"OFF" disables transmitting and receiving.

**NOTE:** If this setting is "OFF," no control change messages will be transmitted or received even if you specify individual control change numbers in step 4.

4. Simultaneously press both ◀, ▶ buttons (4.3) to access the screen where you can set control numbers individually. Use the ◀, ▶ buttons to select each controller.

The controllers will be selected in the following order.

"EXP PDL"	Expression pedal control
"CTRL PDL"	Control switch on/off
"PEDAL FX"	PEDAL effect on/off
"MOD FX"	MODULATION effect on/off
"DELAY FX"	DELAY effect on/off
"REVRB FX"	REVERB effect on/off
"INSRT FX"	External effect on/off
"AMP CTRL"	Amp model on/off (limited to reception)
"CAB CTRL"	Cabinet model on/off (limited to reception)

5. For each controller, specify whether ToneLab LE will transmit and receive control change messages. If you want ToneLab LE to transmit and receive messages for a controller, specify the control change number. Select a controller, and use value knob 6 (2.2) or the ▲, ▼ buttons (4.2) to make the desired setting.  
"OFF": Control change messages will not be transmitted or received.  
"CC00"—"CC95": When you operate a controller, messages of the specified control change number 00–95 will be transmitted. Similarly, ToneLab LE will be controlled when it receives messages of the same control change number from an external MIDI device.
6. To return to the screen where you specify transmit or receive for all control change messages, press both ◀, ▶ buttons (4.3) simultaneously.

## PARAMETER CHANGE (GLOBAL "SYEX OUT")

When you operate ToneLab LE's knobs or buttons to edit the value of a parameter, system exclusive such as parameter changes are transmitted.

If you want ToneLab LE's parameters to be transmitted to an external device, turn the "SYEX OUT" setting "On." Normally, you will turn "SYEX OUT" on when using the Sound Editor.

This setting specifies whether ToneLab LE will transmit parameter changes.

1. Press the GLOBAL button (4.6).
2. Press the ◀, ▶ buttons (4.3) to make the name display (3.1) read "SYEX OUT."
3. Specify whether parameter change messages will be transmitted. Use value knob 3 (2.2) or the ▲, ▼ buttons (4.2) to make your choice.

- “OFF”: Parameter change messages will not be transmitted.
- “On”: Parameter change messages will be transmitted.

**NOTE:** When ToneLab LE receives parameter changes or other system exclusive messages, its parameters, modes, or program numbers will change — regardless of the “SYEX OUT” setting.

## BACKING UP AND RESTORING PROGRAM DATA (GLOBAL “DUMP CUR,” DUMP ALL”)

All of ToneLab LE’s data (including its programs) can be transmitted and received in the form of system exclusive messages. Exchanging this type of data with an external device via system exclusive messages is known as a “data dump.” By performing a data dump, ToneLab LE programs you created can be backed up (saved) on an external device such as a MIDI data filer or a sequencer that is able to transmit and receive system exclusive messages. Then when necessary, you can re-transmit that data back to ToneLab LE to restore it. This provides a way for you to organize large numbers of programs. You can also use this method to copy program data between two connected ToneLab LEs.

You can transfer program data in one of two ways; one program at a time, or all programs at once. When you transmit all programs at once, all of ToneLab LE’s data will also be transmitted, including Dump settings and MIDI settings.

**NOTE:** You can transmit data dumps regardless of the “SYEX OUT” setting. In fact, if you want to transfer program data between two ToneLabs, we recommend that you turn the “SYEX OUT” setting “OFF.” If “SYEX OUT” is “On,” operating the knobs or other controls may change the parameters of the other ToneLab LE in unintended ways.

### BACKING UP

1. Connect ToneLab LE’s MIDI OUT to the MIDI IN of the device that will receive the data dump.
2. If you want to transmit only one program, use Program Select Mode to select the program you want to transmit.
3. Press the GLOBAL button (4.6).
4. Press the ◀, ▶ buttons (4.3) to make the name display (3.1) read “DUMP CUR” or “DUMP ALL.”

“DUMP CUR” (Dump current program data): The data of the currently selected program will be dumped. If you are editing the program (and have not yet saved it), the current settings will be transmitted.

“DUMP ALL” (Dump all data): All of the ToneLab LE’s data will be dumped.

5. Put the receiving device in a mode in which it can record the data dump.

**NOTE:** For details, refer to the owner’s manual of the device that will receive the data dump.

6. Press ToneLab LE’s WRITE button (4.7) to begin transmitting. When transmitting is completed, the display will indicate “COMPLETE,” and you will return to the screen of step 4. (While “DUMP ALL” is being transmitted, the display will indicate “SEND.”)

**NOTE:** While data is being transmitted, do not touch the buttons or knobs of ToneLab LE or its foot controller, and never turn off the power.

### RESTORING

1. Connect the transmitting device’s MIDI OUT to ToneLab LE’s MIDI IN.
2. Set the transmitting MIDI device and ToneLab LE to the same MIDI channel. If ToneLab LE will be receiving data that was previously transmitted to the external MIDI device, select the same MIDI channel as was used when transmitting.

3. Transmit the data dump from the external device.

While ToneLab LE is receiving all data, its display will indicate “RECEIVE.” When reception has been successfully completed, it will indicate “COMPLETE.” If an error occurs, the display will indicate “ERROR”; in this case, try transmitting the data again.

**NOTE:** For details, refer to the owner’s manual of the device that will be transmitting the data dump.

**NOTE:** While data is being transmitted, don’t touch the ToneLab LE’s buttons, pedal, or knobs, and never turn off the power.

4. If you received data for a single program, select the save-destination bank and program, and save the data. (p.26)

**NOTE:** The program data will not be written into ToneLab LE’s program memory unless you store it.

**HINT:** If ToneLab LE receives all data, all of its data will be overwritten automatically. However, the data currently being edited (i.e., the edit buffer) will not be affected.

---

# Restoring the Factory Preset Programs

**H**ere's how you can restore ToneLab LE's programs and all its other settings to the state in which it was shipped from the factory.

**NOTE:** Executing this procedure will erase all the programs you created and saved in ToneLab LE, and will load the factory-set programs. MIDI settings will also be initialized. If there are any settings you want to keep, you should first use the data dump function to back them up, or use the "Program sheet" (the fold-out inside the back cover of this manual) to write down your settings.

1. While holding down the three buttons ▲, ▼ (4.2), and EXIT/TUNE button (4.8), press the STANDBY switch to turn on the power. The bank display (3.4) "P" and the LED 1–4 buttons (5.2) will blink, and the name display (3.1) will ask "RELOAD?" Release the three buttons you were holding down.
2. If at this point you decide that you really don't want to execute this operation, you can press the EXIT/TUNE button.
3. Press the WRITE button (4.7). The name display (3.1) will show "LOADING," and the factory-set data will begin being reloaded. When reloading has been completed, the name display will indicate "COMPLETE," and ToneLab LE will automatically switch to Program Select Mode.

**NOTE:** Never turn off the power while this reload operation is occurring.

# Troubleshooting

If you suspect a malfunction, please check the following points first. If this does not resolve the problem, please contact your dealer or Vox authorized service center.

## 1. The amp isn't powering up when the STANDBY switch is "on"

- Is the AC/AC power supply connected to the rear panel ~AC9V jack?
- Is the AC/AC power supply plugged into an AC outlet?
- Is the STANDBY switched on?
- Could the AC/AC power supply be damaged?

## 2. There's no sound.

- Is your guitar turned up?
- Are both ends of your guitar cable plugged into the correct jacks?
- Is your guitar cable working?
- Could the rear panel OUTPUT LEVEL knob be turned down?
- Check the GAIN, TREBLE, MIDDLE, BASS, VR GAIN, and CH VOLUME settings. For some amp types, you might not hear any sound if the TREBLE, MIDDLE, and BASS settings are turned down — just like the circuitry on the original amp!  
If you are using a pedal effect, check the DRIVE and LEVEL settings as well.
- Could an expression pedal be at the minimum position with a parameter such as DRIVE, LEVEL, VOLUME, GAIN, or VR GAIN assigned to it?
- Could you have activated the Mute function? Press the program select switch to defeat muting.
- Could the PROG LVL parameter value be too low?

## 3. You can't hear any effects even though they're dialed in.

- Are the effect LEDs lit?  
If an LED is dark, the corresponding effect is off. Press the MODE select button to turn on the effect.
- Could the modulation "DEPTH" or the delay/reverb "MIX" be set to a low value?  
Press the MODE select button to select an effect and use the value knobs to adjust the appropriate parameters.
- Could the effect be bypassed?  
If so, press the program select switch to cancel bypass.

**4. You're using the ACOUSTIC pedal effect and getting nasty high frequency distortion.**

- Could the Drive setting be excessively high?
- Are you using a very high output humbucking pickup?  
Either turn down the volume of your guitar, the Amp GAIN or Treble setting for the pedal.

**5. The sound connected to your guitar amp is distorted, or sounds wrong.**

- Could "OUT SEL" switch be set to "Ln1" or "Ln2" (LINE)?
- Could LEVEL be raised excessively?  
→ Make the correct settings as described in Basic Connections.

# Specifications

**NUMBER OF AMP TYPES:** 16

**NUMBER OF CABINET TYPES:** 11

**NUMBER OF EFFECTS**

PEDAL TYPES: 16

MODULATION TYPES: 11

DELAY TYPES: 11

REVERB TYPES: 11

NOISE REDUCTION: 1

**NUMBER OF PROGRAMS:** 120 (30 BANKS x 4 PROGRAMS)

**AUDIO INPUTS**

INPUT x 1

INSERT RETURN x1

**AUDIO OUTPUTS**

OUTPUT x 2

INSERT SEND x1

HEADPHONES x 1

LEVEL knob (adjusts OUTPUT and HEADPHONES)

**DIGITAL AUDIO OUTPUT**

S/P DIF (optical) x 1

**VALVE**

12AX7 (ECC83) x 1

**SIGNAL PROCESSING**

A/D conversion: 24bit

D/A conversion: 24bit

Sampling frequency: 44.1kHz

**TUNER**

TUNING RANGE: A0–C7 (27.5Hz–2093Hz)

TUNER CALIBRATION: A = 438Hz–445Hz

**OTHER**

MIDI IN x 1, MIDI OUT x 1, ~AC9V x 1, STANDBY switch

**DIMENSIONS (W x D x H):** 500 x 249 x 80 (mm)/  
19.69 x 9.80 x 3.15 (inches)

**WEIGHT:** 4.2 kg/9.26 lbs.

**INCLUDED ITEMS:** AC/AC power supply 9VAC  
3.0A

\* Appearance and specifications of this product are subject to change without notice.

Factory  
settings

Trouble-  
shooting

Spec.

# MIDI IMPLEMENTATION CHART

[VOX Valvetronix]

Date : 2006. 4.20

## MIDI Implementation Chart

ToneLab LE

Function	Transmitted	Recognized	Remarks
Basic Channel Default Changed	1 - 16 1 - 16	1 - 16 1 - 16	Memorized
Mode Memorized Messages Altered	X X *****	3 X X	
Note Number: True Voice	X *****	X *****	
Velocity Note On Note Off	X X	X X	
Aftertouch Polyphonic (Key) Monophonic (Channel)	X X	X X	
Pitch Bend	X	X	
Control Change 0-95	○	○	Effect Control *C*2



Program Change	Variable Range	<input type="radio"/> 0-119 *****	<input type="radio"/> 0-119 0-119	* P
System Exclusive		<input type="radio"/>	<input type="radio"/>	Parameter Control Program Data Dump * E * 1
System Common	Song Position Song Select Tune	X X X	X X X	
System Real Time	Clock Command	X X	X X	
Aux Messages	Local On/Off All Notes Off Active Sense Reset	X X X X	X X X X	

**Notes**

\*P: Transmitted if GLOBAL "PCHG OUT" is On.

\*C: Transmitted and received according to the setting of each controller if GLOBAL "CCHG I/O" is On.

\*E: Transmitted if GLOBAL "SYEX OUT" is On. (Responses to Request messages are always transmitted regardless of the "SYEX OUT" setting.)

\*1: In addition to messages specifically for this device, Device Inquiry is also supported.

\*2: "AMP CTRL" and "CAB CTRL" can be received but cannot be transmitted.

Mode 1: OMNI ON, POLY

Mode 2: OMNI ON, MONO

: Yes

Mode 3: OMNI OFF, POLY

Mode 4: OMNI OFF, MONO

: No

Consult your local VOX distributor for more information on MIDI Implementation.

---

# Index

## Numerics

0dB 20

## A

amp model 28  
AMP Models 27  
AMP/LINE 21  
AP1 21  
AP2 21  
AP3 21  
automatic chromatic tuner 46

## B

Backing up 53  
Bank 22  
Bypass 46

## C

Cabinet 31  
CABINET Models 31  
Calibrating 46  
CC 52  
CCHG I/O 52  
CH VOLUME 28  
CHAIN 25  
Connections 19, 51  
Control Change 52  
Control switch 49

## D

DELAY Effects 41  
duck 42  
DUMP ALL 53  
DUMP CUR 53

## E

Effect On/Off mode 22  
EQ 25  
equalizer 25  
Expression pedal 47  
    Expression Target 47  
    Sensitivity of the Pedal 50

## F

FACTOR 49  
Factory Preset Programs 54

## G

GAIN 27

## K

Key Lock 23

## L

Ln1 21  
Ln2 21

## M

MIDI 51  
MIDI CH 51  
MIDI Channel 51  
MIDI device 20  
Modulation Effects 37  
Mute 46

## N

name 26

## O

ORIG icon 26  
original value 26  
Output settings 21

## P

Parameter Change 52  
PCHG OUT 51  
PEDAL Effects 34  
PRESENCE control 27  
preset program 22, 24  
Program Change 51  
Program Data 53  
program name 26  
Program Select mode 22  
programs 22

## Q

Quick Assign 47

## R

RELOAD? 54  
RENAME 26  
Restoring 53

REVERB Effects 44

## S

S/P DIF connector 20  
Silent Tuning mode 46  
Sound Editor 9, 52  
speaker 31  
SYEX OUT 52

## T

Three-band Equalizer 25  
TONE CONTROLS 27  
Tube 28  
Tuner 46

## V

Valve 18  
Valve Reactor 10  
Volume 27  
VR GAIN 28

## W

WRITE 26

### IMPORTANT NOTICE TO CONSUMERS

This product has been manufactured according to strict specifications and voltage requirements that are applicable in the country in which it is intended that this product should be used. If you have purchased this product via the internet, through mail order, and/or via a telephone sale, you must verify that this product is intended to be used in the country in which you reside.

**WARNING:** Use of this product in any country other than that for which it is intended could be dangerous and could invalidate the manufacturer's or distributor's warranty.

Please also retain your receipt as proof of purchase otherwise your product may be disqualified from the manufacturer's or distributor's warranty.



VOX AMPLIFICATION LTD. 9 Newmarket Court, Kingston, Milton Keynes, MK10 OAU, UK <http://www.voxamps.co.uk/>