

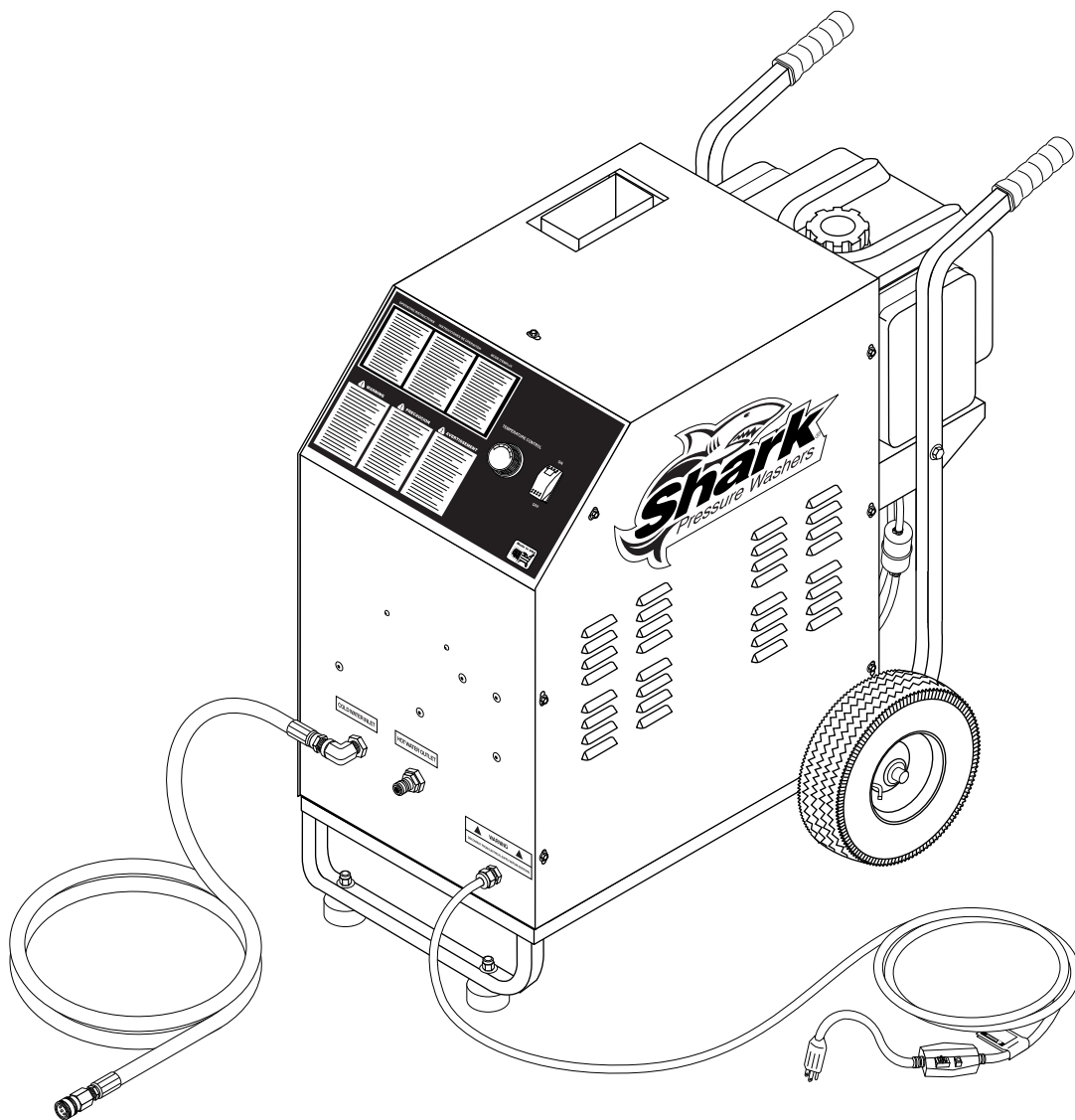

MODEL: HP

OPERATING INSTRUCTION AND PARTS MANUAL

■ HP-5030D



MACHINE SPECIFICATIONS

- **Pump Volume At Pump Head:**

HP-5030D 5 GPM

- **Pump Pressure At Pump Head:**

HP-5030D 3000 PSI

- **Burner Type:**

HP-5030D Oil Fired - 380,000 BTU/Hr.

- **Burner Fuel Pressure:**

HP-5030D 120 PSI

- **Machine Voltage:**

HP-5030D 120V/1Ph

- **Total Machine Amperage:**

HP-5030D 15 Amps

- **Shipping Weight:**

HP-5030D 315 Lbs.

- **Exhaust Stack Size:**

HP-5030D 3.5" x 6.5"

- **Machine Dimensions:** **HP-5030D** Length = 29" Width = 41" Height = 47"

CONTENTS

Introduction	4	Maintenance and Service	8-9
Important Safety Information	4-5	HP-5030D Exploded View	10
Installation	5,8	HP-5030D Exploded View Parts List	11
Component Identification, HP-5030D	6	Burner Assembly, Exploded View	12
Starting and Operating Instructions	7	Burner Assembly Exploded View Parts Lists	13
Preventative Maintenance	7-8	Troubleshooting	14-15
Field Service of Fuel Pump	9	Preventative Maintenance	16
		Warranty	

SERIAL NUMBER:
DATE PURCHASED:
FOR SALES AND SERVICE, PLEASE CONTACT:

INTRODUCTION

Thank you for purchasing a Shark HP.

This manual covers the operation and maintenance of the HP-5030D heater module. All information in this manual is based on the latest product information available at the time of printing.

The HP is designed to heat water from a cold water pressure washer. Maximum water flow is 5 GPM and maximum pressure is 3000 PSI. Flow rate of 3 GPM will achieve an average temperature of about 180°F. Temperature is dependent on inlet water temperature and water flow rate.

We reserve the right to make changes at any time without incurring any obligation.

Owner/User Responsibility:

The owner and/or user must have an understanding of the manufacturer's operating instructions and warnings before using this hot water generator. Warning information should be emphasized and understood. If the operator is not fluent in English, the manufacturer's instructions and warnings shall be read to and discussed with the operator in the operator's native language by the purchaser/owner, making sure that the operator comprehends its contents.

Owner and/or user must study and maintain for future reference the manufacturers' instructions.

This manual should be considered a permanent part of the machine and should remain with it if machine is resold.

When ordering parts, please specify model and serial number.

IMPORTANT SAFETY INFORMATION

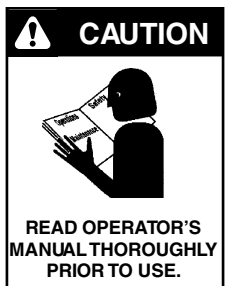

CAUTION: To reduce the risk of injury, read operating instructions carefully before using.

1. Read the owner's manual thoroughly. Failure to follow instructions could cause malfunction of the machine and result in death, serious bodily injury and/or property damage.
2. All installations must comply with local codes. Contact your electrician, plumber, utility company or the selling distributor for specific details.

To comply with the National Electrical Code (NGPA 70) and provide additional protection from risk of electric shock, this hot water generator is equipped with a UL approved ground fault circuit interrupter (GFCI) power cord.



WARNING: Flammable liquids can create fumes which can ignite causing property damage or severe injury.

WARNING: Do not use gasoline, crankcase drainings or oil containing gasoline, solvents or alcohol. Doing so will result in fire and/or explosion.

WARNING: Do not spray flammable liquids. Operate only where an open torch is permitted.

3. This fuel burning machine shall be installed only in locations where combustible dusts and flammable gases or vapors are not present.
4. In these oil burning models, use only kerosene, No. 1 home heating fuel, or diesel fuel.
5. Risk of explosion — Do not spray flammable liquids. Operate only where open flame or torch is permitted.



WARNING: Keep water spray, wand and high pressure hose away from electric wiring or fatal electric shock may result. Read warning tag on electrical cord.

6. To protect the operator from electrical shock, the machine must be electrically grounded. It is the responsibility of the

owner to connect this machine to a UL grounded receptacle of proper voltage and amperage ratings. Do not spray water on or near electrical components. Do not touch machine with wet hands or while standing in water. Always disconnect power before servicing.

WARNING: Spray gun kicks back — hold with both hands.

7. Grip cleaning wand of attached pressure washer securely with both hands before starting cleaner. Failure to do this could result in injury from a whipping wand.



WARNING: High pressure stream of fluid that this equipment can produce can pierce the skin and its underlying tissues, leading to serious injury and possible amputation.

8. High pressure developed by the attached pressure washer can cause bodily injury or damage. Use caution when operating. Do not point the spray gun at anyone or at any part of the body. This machine is to be used only by qualified operators.
9. Never make adjustments on machine while it is in operation.



WARNING: High pressure spray can cause paint chips or other particles to become airborne and fly at high speeds.

10. Eye safety devices must be worn when using this equipment.

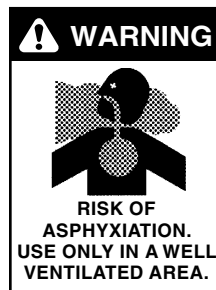

WARNING: Risk of asphyxiation — Use this product only in a well ventilated area.

11. When the machine is working, do not cover or place in a closed space where ventilation is insufficient.



WARNING: Risk of fire — Do not add fuel when the machine is operating or still hot.

12. Attached pressure washer with a spray gun should not be operated with the spray gun in the OFF position for extended periods of time as this may cause damage to the pump.

Check to make sure burner shuts off when spray gun trigger is closed.

13. Protect from freezing.
14. To prevent a serious injury, make certain quick coupler on discharge hose has locked before using pressure washer.
15. Do not allow acids, caustic or abrasive fluids to pass through the HP.
16. Inlet water must be from a cold water pressure washer (3,000 PSI maximum).
17. Do not allow CHILDREN to operate the pressure washer at any time. **THIS MACHINE MUST BE ATTENDED DURING OPERATION.**
18. The best insurance against an accident is precaution and knowledge of the machine.
19. Do not operate this product when fatigued or under

the influence of alcohol or drugs. Keep operating area clear of all persons.

20. We will not be liable for any changes made to our standard machines, or any components not purchased from us.
21. Do not overreach or stand on unstable support. Keep good footing and balance at all times.
22. Follow the maintenance instructions specified in the manual.
23. When making repairs disconnect from electrical source.
24. Turn burner off and open spray gun to allow water to flow and cool coil to 100°F before turning machine off.
25. Before disconnecting high pressure hose from HP water outlet, open spray gun to relieve back pressure in hose.

CAUTION: This machine produces hot water and must have insulated components attached to protect the operator.

INSTALLATION

Place machine in a convenient location providing ample support, drainage and room for maintenance.

Remove bolts from pallet to foot bracket. Install rubber feet provided as shown on page 11, item #26.

Location:

The location should protect the machine from damaging environmental conditions, such as; wind, rain, and freezing.

1. This machine should be run on a level surface where it is not readily influenced by outside sources such as strong winds, freezing temperatures, rain, etc. It should be located to allow accessibility for refilling of fuel, adjustments and maintenance. Normal precautions should be taken by the operator of the machine to prevent moisture from reaching the electrical controls.
2. It is recommended that a partition be made between the wash area and the machine to prevent water spray from coming in contact with the machine. Excess moisture reaching any electric components or electrical controls will reduce machine life and may cause electrical shorts.
3. During installation of the machine, beware of poorly ventilated locations or areas where exhaust fans may cause an insufficient supply of oxygen. Sufficient combustion can only be obtained when there is a sufficient supply of oxygen available for the amount of fuel being burned. If it is necessary to install a machine in a poorly ventilated area, outside fresh air may have to be piped to the burner and a fan installed to bring air into the machine.

COMPONENT IDENTIFICATION

CAUTION HOT WATER:
Must use insulated
spray gun and wand.

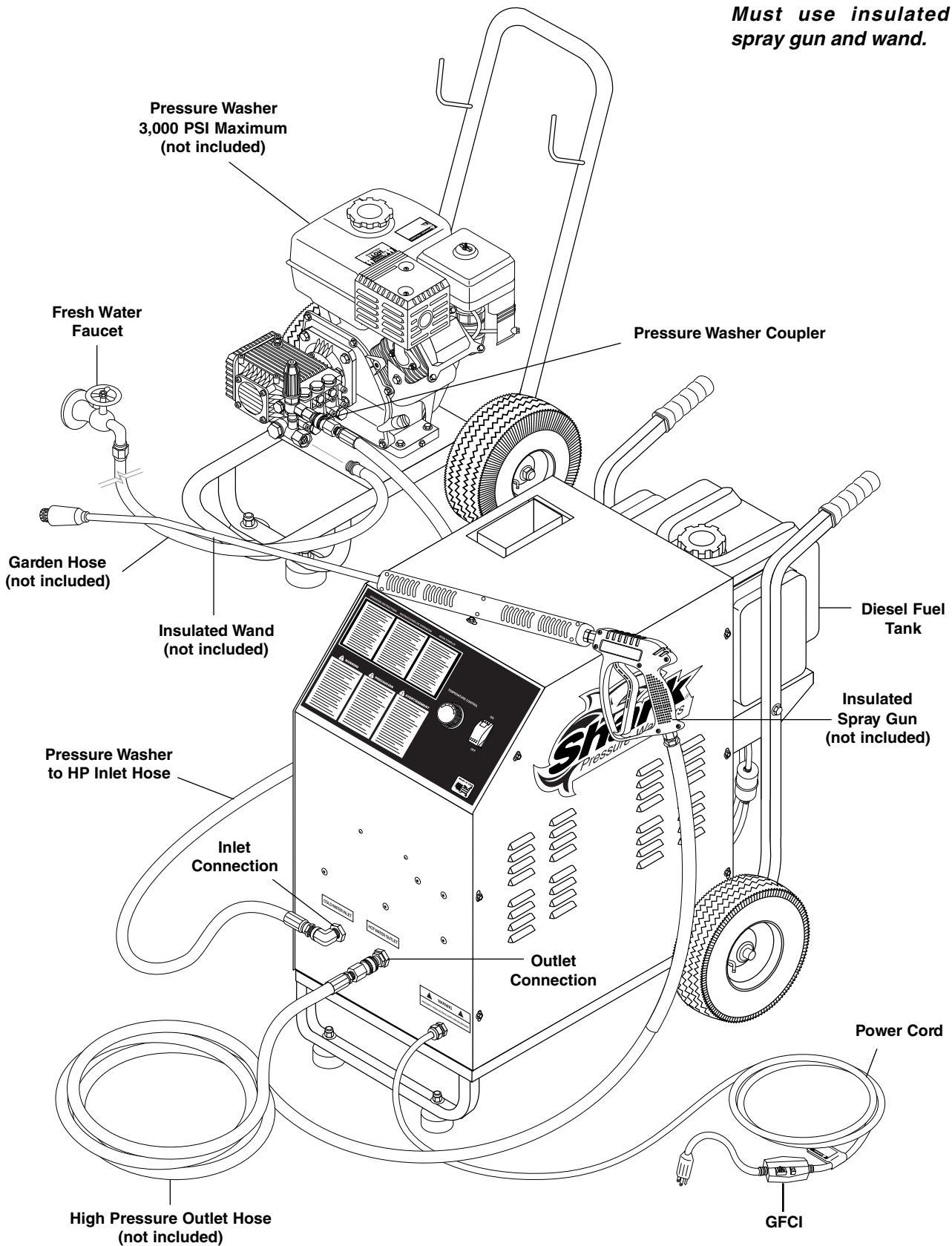

Electrical:

This machine, when installed, must be electrically grounded in accordance to local codes. Check for proper power supply using a volt meter.

Placement:

Do not locate near any combustible material. Keep all flammable material at least 20 feet away.

Allow enough space for servicing the machine.

Local code will require certain distances from floor and walls. (Two feet away from walls should be adequate.)

Water Source:

The water source for the pressure washer should be supplied by a minimum 5/8" I.D. garden hose with a city water pressure of not less than 30 PSI. If the water supply is inadequate, or if the garden hose is kinked, the attached pressure washer will run very rough and the burner will not fire.

Connection:

See Component Identification on page 6.

Venting:

Adding exhaust vent pipe to your oil fired burner is not recommended because restricted air flow causes carbon build-up, which affects the operation, and increases maintenance on the coil. If a stack must be used, refrain from using 90 degree bends. If the pipe can not go straight up then use only 45 degree bends and go to the next size pipe. The overall pipe length must not exceed 6 feet in length.

STARTING AND OPERATING INSTRUCTIONS

To Start:

1. **STOP!** Read operator's manual from both the pressure washer and the HP before operating. Failure to read operation and warning instructions may result in personal injury or property damage.
2. Check fuel tank and pump oil levels on both machines.
3. Connect garden hose to pressure washer.

CAUTION: Only use fresh water to this machine.

4. Attach high pressure hose between pressure washer and HP, as shown on page 6. Turn garden hose water on. Additional adapters and couplers may be needed to connect your brand of pressure washer to the HP.
5. Connect the power cord into the proper electrical outlet, then push in the GFCI reset button.

Shark HP • Rev. 1/03

6. Start up attached pressure washer according to the manufacturers instructions. When a steady stream of water flows from the spray gun and wand the machine is ready for cold water cleaning.
7. For hot water washing, turn the HP burner switch to the ON position. Adjust thermostat to desired temperature setting. (The burner will light automatically.)

To Stop:

1. If using an optional detergent injector, place the detergent line in a bucket of water allowing detergent to be flushed from system.
2. Turn HP burner switch off and continue spraying water, allowing the water to cool.
3. After water has cooled to less than 100°F, turn the attached pressure washer off.
4. Turn garden hose water off. Open the spray gun to relieve remaining pressure.
5. Protect from freezing.

PREVENTATIVE MAINTENANCE

1. Use clean fuel - kerosene, No. 1 home heating fuel or diesel. Clean or replace fuel filter every 100 hours of operation. Avoid water contaminated fuel as it will seize up the fuel pump. De-soot coils monthly. Use an additive if diesel is being used.
2. Check to see that the attached pressure washer water pump is properly lubricated.
3. Follow winterizing instructions to prevent freeze damage to pump and coils.
4. Always neutralize and flush detergent from system after use.
5. If water is known to be high in mineral content, use a water softener on your water system, or de-scale as needed.
6. Do not allow acidic, caustic or abrasive fluids to be pumped through system.
7. Always use high grade quality cleaning products.
8. Never run attached pressure washer pump dry for extended periods of time.
9. If machine is operated with smoky or eye burning exhaust, coils will soot up, not letting water reach maximum operating temperature. (See section on Maintenance and Service).
10. Never allow water to be sprayed on or near the motor or burner assembly or any electrical component.
11. Delime coils as per instructions.

It is advisable, periodically, to visually inspect the burner. Check air inlet to make sure it is not clogged or blocked. Wipe off any oil spills and keep equipment clean and dry.

The areas around the HP should be kept clean and free of combustible materials, gasoline and other flammable vapors and liquids.

The flow of ventilating air to the burner must not be blocked or obstructed in any manner.

MAINTENANCE AND SERVICE

Winterizing Procedure:

Damage due to freezing is not covered by warranty. Adhere to the following cold weather procedures whenever the washer must be stored or operated outdoors under freezing conditions.

During winter months, when temperatures drop below 32°F, protecting your machine against freezing is necessary. Store the machine in a heated room. If this is not possible use compressed air on the short hose end. By injecting compressed air, all water will be blown out of the system. Run anti-freeze through the system.

Rupture Disk:

For safety, each machine is equipped with a rupture disk. In the event the pressure of the water should exceed 8000 PSI, the rupture disk will release pressure and water on to the ground.

When the disk ruptures, it will need to be replaced.

NOTE: Turn burner switch off. Then open spray gun to cool heating coil or rupture disk will burst over time.

Adjustable Thermostat:

The adjustable thermostat can be set between 100°F to 225°F (37.8° to 108°C). The temperature is dependent on water flow and ambient water temperature.

Cleaning of Coils:

In alkaline water areas, lime deposits can accumulate rapidly inside the coil pipes. This growth is increased by the extreme heat build up in the coil. The best prevention for liming conditions is to use high quality cleaning detergents. In areas where alkaline water is an extreme problem, periodic use of Deliming Powder will remove lime and other deposits before coil becomes plugged.

Deliming Coils With A Pressure Washer:

Periodic flushing of coils or optional float tank is recommended.

Step 1 Fill a 5 gallon bucket with 4 gallons of water, then add 1 lb. of deliming powder. Mix thoroughly.

Step 2 Remove the high pressure nozzle from the pressure wand and put the wand into the bucket. Secure the trigger on the spray gun in the open position.

Step 3 Attach a short section (3-5 ft.) of garden hose to the attached pressure washer to siphon solution from the elevated bucket. Start up pressure washer, allowing solution to be pumped through pressure washer and into HP coils and back into the bucket. Solution should be allowed to circulate 2-4 hours.

Step 4 After circulating solution flush entire system with fresh water.

Removal of Soot In Heating Coil:

In the heating process fuel residue, in the form of soot deposits, may develop between the heating coil pipes and block air flow which affects burner combustion. When soot has been detected on visual observation, the soot on the coil must be cleaned off.

Fuel:

Use clean fuel oil that is not contaminated with water and debris. Replace fuel filter and drain tank every 100 hours of operation. Use Kerosene No. 1 or No. 2 Heating Fuel (ASTM D306) or diesel only. **NEVER** use gasoline in your burner tank. Gasoline is more combustible than fuel oil and could result in a serious explosion. **NEVER** use crankcase or waste oil in your burner. Fuel machine malfunction could result from contamination.

Ignition Circuit:

Periodically inspect wires, spring contact and electrodes for condition, security and proper spacing. **(CAUTION: 10,000 VOLTS)**

Electrode Setting:

(See illustration below)

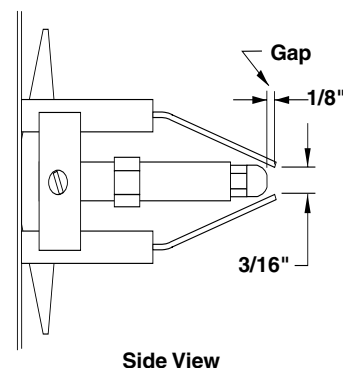

Electrodes Check : Periodically check wiring connections. If necessary to adjust electrodes, use diagram.

Burner Nozzle:

Keep the tip free of surface deposits by wiping it with a clean, solvent-saturated cloth, being careful not to plug or enlarge the nozzle. For maximum efficiency, replace the nozzle each season. Select nozzle size based on the pressure washer you will be using:

Nozzle	Pressure Washer GPM
1.50	2 - 3
1.75	3 - 4
2.00 - 2.25	4 - 5

All nozzles should be 45° W

Fuel Control System:

The HP utilizes a fuel solenoid valve located on the fuel pump to control the flow of fuel to the combustion chamber. This solenoid, which is normally closed, is activated by a flow switch when water is flowing through it. When an operator releases the trigger on the spray gun, the flow of water through the flow switch stops, turning off the current to the fuel solenoid. The solenoid then closes, shutting off the supply of fuel to the combustion chamber. Controlling the flow of fuel in this way gives an instantaneous burn or no burn situation, thereby eliminating high and low water temperatures, and combustion smoke normally associated with machines incorporating a spray gun. Periodic inspection is recommended to insure that the fuel solenoid valve functions properly. This can be done by operating the machine and checking to see that when the trigger on the spray gun is in the off position, the burner is not firing.

Fuel Pressure Adjustment:

To adjust fuel pressure, turn the adjusting screw with a 5/32" Allen Wrench (located on the fuel pump) clockwise to increase, counterclockwise to decrease. Do not exceed 200 PSI.

FIELD REPAIR INSTRUCTIONS

HP Fuel Pump:

1. Remove the screws 10/32" Allen Head from the HP hood.
2. Remove louvered HP hood.
3. With a 9/16" wrench, loosen (**DO NOT REMOVE**) the two 3/8" x 3/4" HH NC serrated flange bolts that secure the HP front panel.
4. With a 2.5 mm hex head wrench (Allen Wrench), loosen the three set screws that hold the fuel pump in the blower motor housing located on Idromatic Boiler Assembly.

5. Carefully remove the fuel pump (Item #53) from the blower motor, leaving the flexible zinc fuel line connected, carefully bend the fuel line and fuel pump away from the blower motor.
6. Locate the fuel pump/fan motor coupling.
7. Inspect the coupling for damage. The inside diameter of fuel pump coupling requires flat on one side to engage fuel pump, and the outside diameter requires two male notches to engage the blower motor.
8. Perform a check to see if the fuel pump is turning freely. Use an open end 7mm wrench or small adjustable wrench on fuel pump shaft.
9. Spin the fuel pump over in both directions using the wrench for leverage. When the fuel pump is turning freely (almost to the point you could turn it by hand) it is ready to reinstall.
10. Align fuel pump coupler on pump shaft/fan motor. Slide pump into fan motor. Secure pump with the three set screws.
11. Test machine (make sure):
 - Blower motor spins
 - Fuel is on
 - Machine has power to it
 - Switch is on
 - Flow of water through machine
 - Thermostat is turned up
 - Flow switch is adjusted properly
12. When HP is operating properly, turn machine off, tighten front panel, and install hood and 13 self tapping screws with recess washers.

**HP-5030D
EXPLODED VIEW**

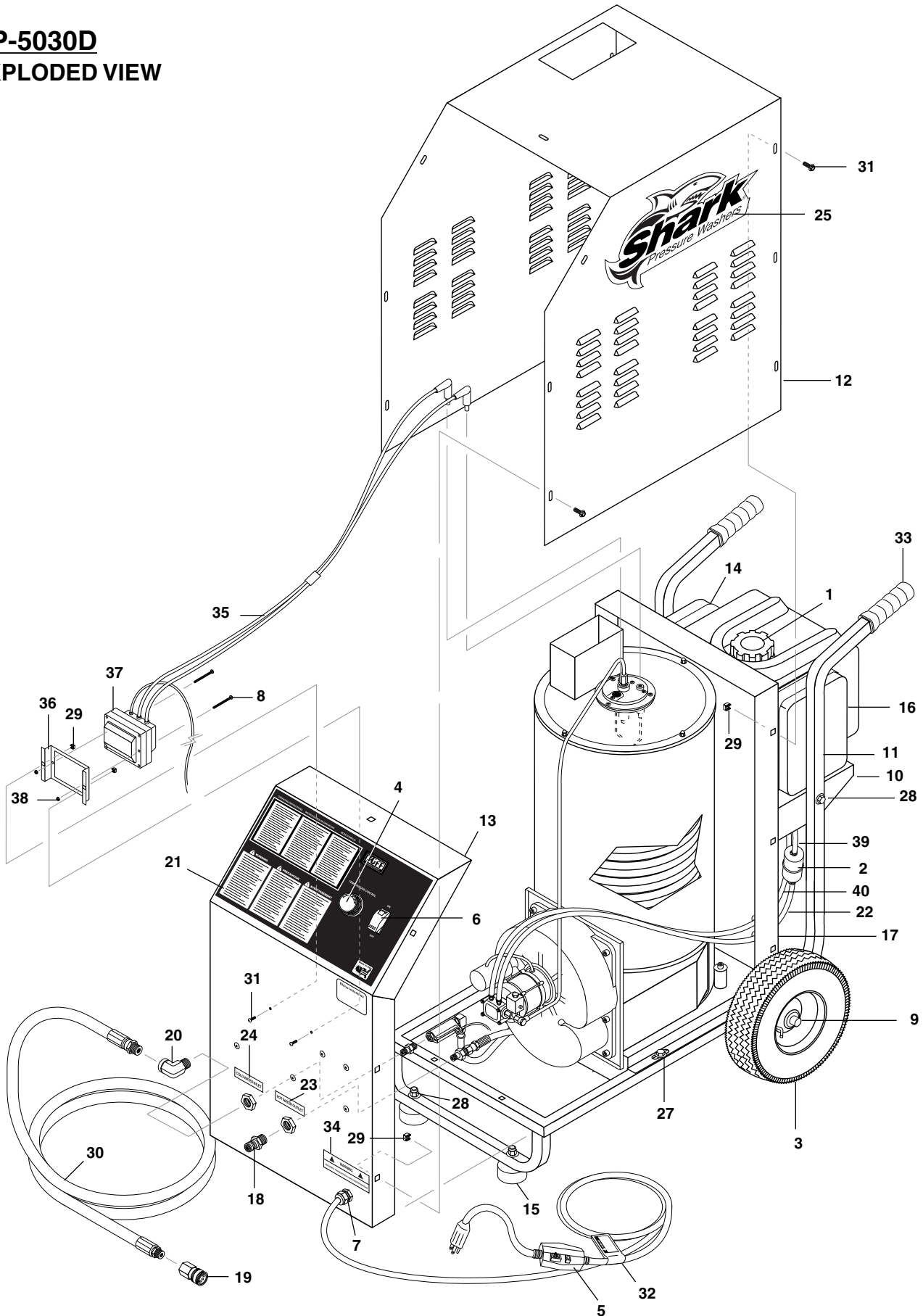

HP-5030D EXPLODED VIEW PARTS LIST

ITEM	PART NO.	DESCRIPTION	QTY	ITEM	PART NO.	DESCRIPTION	QTY
1	2-01167	Cap, Fuel Tank, Plastic	1	17	95-07200120	Panel, Back	1
2	2-99031	Filter, Diesel Fuel, Disposable	1		90-1996	▲ Bolt, 3/8" x 3/4" Whiz	4
3	4-0303	Wheel & Tire, 6" Steel Rim	2		90-2020	▲ Nut Cage, 3/8" x 12 GA	4
4	4-05088	Thermostat, Adjustable, 302°F	1	18	2-2007	Nipple, 3/8" x 3/8" NPT ST Male	1
5	6-01062	GFCI, 120V 15A, w/36' 12-3 Cord	1	19	2-2002	Coupler, 3/8" Fem, Brass	1
6	6-020240	Switch, Rocker, Carling w/Green Lens	1	20	2-0031	Elbow, 3/8" Street	1
7	6-05152	Strain Relief, Strt, LQ Tite 3231 Small	1	21	11-0110	Label, Control Panel	1
8	90-1987	Screw, 6/32" x 2"	2	22	4-02100003	Fuel Line, 1/4" Push-On, Green (36")	1
9	90-20041	Collar, 5/8" Bore Shaft 3010	2	23	10-09004	Decal, Discharge	1
	95-07102225	▲ Axle	1	24	10-09003	Decal, Inlet	1
	90-4005	▲ Washer, 5/8"	4	25	11-013	Label, Shark Logo	2
10	95-07200122	Bracket, Fuel Tank, Left	1	26	90-20061	▲ Nut, 5/16", Cap	2
	95-07200124	Bracket, Fuel Tank, Right	1	27	90-1018	Bolt, 5/16" x 1-3/4"	4
11	95-07200125	Frame Assy	1		90-4002	Washer, 3/4", Flat	4
	90-1996	▲ Bolt, 3/8" x 3/4" Whiz	4		90-2002	Nut, Whiz Loc, 5/16" Flange	4
	90-2020	▲ Nut Cage, 3/8" x 12 GA	4	28	90-1004	Bolt, 1/4" x 1-1/2"	2
	90-2022	▲ Nut Cage, 1/4" x 16 GA	4		90-4000	Washer, 1/4", Flat	2
12	95-07200123	Hood, Cover Panel	1		90-200012	Nut, 1/4" Flange	2
	95-07290056	Hood, Eurotec Coil	1	29	90-2018	Nut, Cage, 10/32" x 16 Ga.	15
	11-0101	▲ Label, Warning, Pictorial	1	30	4-0204509	Hose, 3/8" x 9', 2 Wire, 3/8" SW, x 3/8" SOL	1
	10-02025A	▲ Label, Hot/Caliente w/Arrows	1	31	90-1991	Screw, 10/32" x 1/2"	15
13	95-07200121	Panel, Front	1	32	10-08018	Label, Warning, Service Cord	1
	6-05040	▲ Block, Terminal, 8 Pole	1	33	2-01103	Grip, 1" Sqr. Handle	2
	11-1042	▲ Label, Ground	1	34	10-08021	Label, Disconnect Pwr Supply	1
14	95-07102287	Strap, Fuel Tank	2	35	7-726679	Ignition Wire/Silicon Cable	2
15	2-01015	Bumber, Rubber 1" w/Bolt, 5/16" x 1-1/4"	2	36	95-07102279	Bracket, Transformer Mount	1
16	2-011507	Tank, Encore 5 Gal Fuel	1	37	7-40050	Transformer, 115V	1
	2-1084	▲ Hose Barb, 1/4" Barb x 1/8" Pipe	1	38	90-200430	Nut, 6/32", Keps	2
	2-010061	▲ Grommet, Fuel Tank	1	39	4-02100003	Fuel Line, 1/4" Push-On, Green (6")	1
	7-80320	▲ Valve, Fuel Tank Shut-Off	1	40	4-02100000	Fuel Line, 1/4", Black (46")	1
						▲ Not Shown	

**HP-5030D BURNER ASSEMBLY
EXPLODED VIEW PARTS LIST**

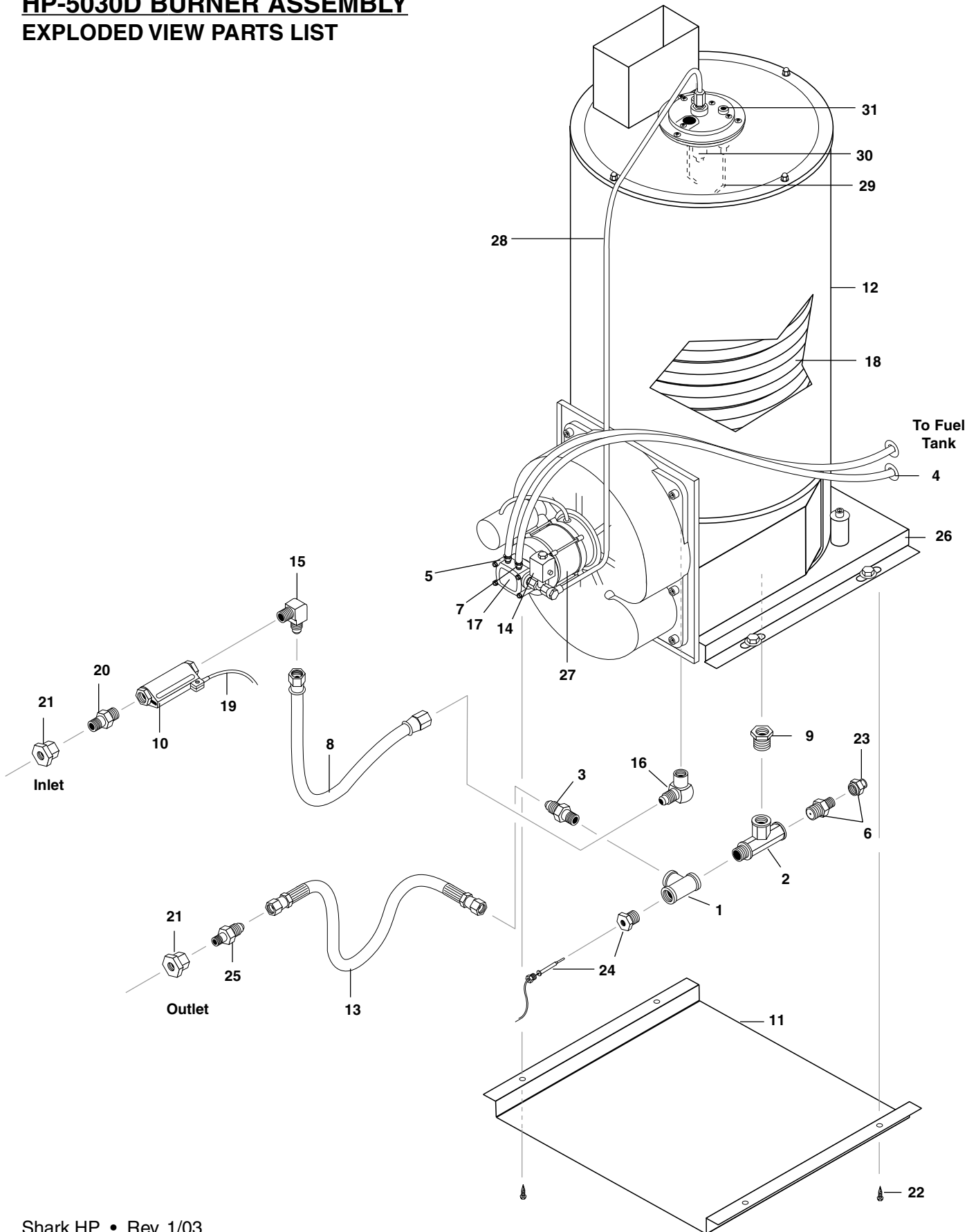

HP-5030D BURNER ASSEMBLY EXPLODED VIEW PARTS LIST

ITEM	PART NO.	DESCRIPTION	QTY	ITEM	PART NO.	DESCRIPTION	QTY
1	2-0036	Tee, 1/2", Fem., Steel Pipe	1	17	7-50044	▲ Coupling, Fuel Pump	1
2	2-0046	Tee, 1/2", Street	1	18	7-15070	Coil Replacement	1
3	2-0052	Nipple, 1/2" JIC x 1/2" Pipe	1	19	6-021740	Reed, Replacement, MV60	1
	2-0054	▲ Elbow, 1/2" JIC x 1/2" Male	1	20	2-0006	Nipple, 3/8" x 3/8" Hex, Steel	1
4	2-0103	Grommet, Rubber, Nozzle Holder	2	21	2-11039	Connector, 3/8" Anchor	2
5	2-1084	Hose Barb, 1/4" Barb x 1/8" ML Pipe	2	22	90-19711	Screw, 1/4" x 1/2", Whiz Loc	4
6	2-3408	Disk, Rupture Assy, 8000 PSI	1	23	2-3480	Replacement, Disk 8000 PSI	1
7	2-9040	Clamp, Hose, UNI, .46-.54	6	24	4-05088	Thermostat, Adjustable, 302°F	1
8	4-02047716	Hose, 3/8" x 16", 2 Wire, Pressure Loop	1	25	2-0051	Nipple, 1/2" JIC x 3/8" Pipe	1
9	2-00681	Bushing, 1/2" x 3/8"	1		2-0053	Elbow (3535, 4030)	1
10	6-021730	Switch, Flow, MV60	1	26	95-07290050	Coil Stand, 2" (5530D)	1
11	95-07102288	Guard, Boiler/Plumbing	1		95-07290054	Coil Stand, 4.25" (4030D)	1
12	91-01017	Burner, Hotbox	1		90-1006	▲ Bolt, 5/16" x 3/4"	4
13	4-02047722	Hose, 3/8" x 22", 2 Wire, Pressure Loop	1		90-4001	▲ Washer, 5/16"	8
14	7-40112	Solenoid, w/Valve, 115V 60 HZ	1		90-2001	▲ Nut, 5/16" ESNA	4
15	2-0053	Elbow, 1/2" JIC x 3/8", 90°	1	27	7-00220	Motor, Burner, 115V 60 HZ	1
16	2-00602	Elbow, 1/2" JIC x 1/2" Fem, 90°	1		7-50034	▲ Blower Wheel	1
	2-00601	Elbow, 1/2" JIC x 3/8" Male (5530, 4030)	1	28	7-25086	Fuel Line	1
17	7-00216	Fuel Pump	1	29	7-55041	Electrodes	2
				30	7-25079	Holder, Fuel Nozzle	1
				31	7-55029	Site Glass	1
						▲ Not Shown	

TROUBLESHOOTING

PROBLEM	POSSIBLE CAUSE	SOLUTION
BURNER WILL NOT LIGHT	Disconnected or short in electrical wiring	All wire contacts should be clean and tight. No breaks in wire.
	Burner motor thermal protector tripped	If tripped, check voltage, connections and extensions for cause. Check fuel pump shaft rotation for binding, causing motor to overheat.
	ON/OFF switch defective	Check continuity through burner switch.
	Heavy sooting on coil and burner, can cause interruption of air flow and shorting of electrodes	Clean as required.
	Improper electrode setting	Clean and test according to diagram in operator's manual.
	Fuel not reaching combustion chamber	Check fuel pump for proper flow. Check solenoid flow switch on machines with spray gun control for proper ON/OFF flow switch.
	Fuel solenoid malfunction	Check by placing screwdriver inside coil then turn machine on, open spray gun and check for magnetic pull.
	Clogged burner nozzle	Replace.
	Water not turned on	Turn on water to activate burner flow switch.
	Flow switch malfunction	Remove, test for continuity and replace as needed.
MACHINE SMOKES	Improper fuel or water in fuel	Drain tank and replace contaminated fuel.
	Low fuel pressure	Adjust fuel pump pressure to specifications.
	Air leaks in fuel lines	Check fuel lines for leaks or air bubbles. Tighten or replace as needed.
	Plugged or dirty burner nozzle	Replace.
	Faulty burner nozzle spray pattern	Replace nozzle.
	Heavy accumulation of soot on coils and burner assembly	Remove coils and burner assembly. Clean thoroughly.
	Misaligned electrode	Realign electrodes to specifications.
	Fuel filter partially clogged	Replace as needed.
	Obstruction in smoke stack	Check for insulation blockage or other foreign objects.
	Soot build-up on coils	Clean coils with soot remover.
	Lime build-up in coils	Clean inside of coils using coil cleaner.

TROUBLESHOOTING

PROBLEM	POSSIBLE CAUSE	SOLUTION
LOW WATER TEMPERATURE	Improper fuel or water in fuel	Drain fuel tank and replace with proper fuel.
	Low fuel pressure	Increase fuel pressure.
	Weak fuel pump	Check fuel pump temperature. Replace pump if needed.
	Fuel filter partially clogged	Replace as needed.
	Soot build up on coils	Clean coils with soot remover.
	Lime build up on coils	Clean inside of coils using Shark's coil cleaner.
	Improper burner nozzle	See specifications.
WATER TEMPERATURE TOO HOT	Incoming water to machine warm or hot	Lower incoming water temperature.
	Fuel pump pressure too high	Lower fuel pressure.
	Fuel pump defective	Replace fuel pump.
	Detergent line sucking air	Tighten all clamps. Check detergent line for holes.
	Defective high limit switch (thermostat)	Replace.
	Incorrect fuel nozzle size	See Burner Nozzle section.
	Insufficient water supplied	Check GPM to machine.
	Restricted water flow	Check nozzle for obstruction, proper size.

PREVENTATIVE MAINTENANCE

MAINTENANCE SCHEDULE		
Machine	Clean	Daily
Water Lines	Check	Daily
Fittings	Check	Daily
Fuel Filter	Clean	Weekly
Inlet Strainer	Clean	Weekly
Fuel Nozzle	Clean	Weekly
Fuel Tank	Clean	Weekly
Electrodes	Adjust	Monthly
Fuel Pump Strainer	Clean	Monthly
Electrode Wires	Check	Monthly



HP SERIES HEATER MODULE WARRANTY

SHARK LIMITED NEW PRODUCT WARRANTY PRESSURE WASHERS

WHAT THIS WARRANTY COVERS

All SHARK PRESSURE WASHERS are warranted by SHARK to the original purchaser to be free from defects in materials and workmanship under normal use, for the periods specified below. This Limited Warranty is subject to the exclusions shown below, is calculated from the date of the original purchase, and applies to the original components only. Any parts replaced under this warranty will assume the remainder of the part's warranty period. This warranty applies to the original purchaser and is not transferable.

LIMITED LIFETIME PARTS WARRANTY:

Components manufactured by SHARK, such as frames, handles, coil wraps, float tanks, and belt guards. Forged brass pump manifold. All heating coils will have a three year warranty. Internal components on the oil-end of all pressure washer pumps will have a seven year warranty.

ONE YEAR PARTS WARRANTY:

All other components, excluding normal wear items as described below, will be warranted for one year on parts. Warranty on these parts will be for one year regardless of the duration of the original component manufacturer's part warranty.

WARRANTY PROVIDED BY OTHER MANUFACTURERS:

Motors, generators, and engines, which are warranted by their respective manufacturers, are serviced through these manufacturers' local authorized service centers. SHARK cannot provide warranty on these items.

WHAT THIS WARRANTY DOES NOT COVER

This warranty does not cover the following items:

1. Normal wear items, such as nozzles, guns, discharge hoses, wands, quick couplers, seals, filters, gaskets, O-rings, packings, pistons, pump valve assemblies, strainers, belts, brushes, rupture disks, fuses, pump protectors.
2. Damage or malfunctions resulting from accidents, abuse, modifications, alterations, incorrect installation, improper servicing, failure to follow manufacturer's maintenance instructions, or use of the equipment beyond its stated usage specifications as contained in the operator's manual.
3. Damage due to freezing, chemical deterioration, scale buildup, rust, corrosion, or thermal expansion.
4. Damage to components from fluctuations in electrical or water supply.
5. Normal maintenance service, including adjustments, fuel system cleaning, and clearing of obstructions.
6. Transportation to service center, shop labor charges, field labor charges, or freight damage.

WHAT YOU MUST DO TO OBTAIN WARRANTY SERVICE

While not required for warranty service, we request that you register your SHARK pressure washer by returning the completed registration card. In order to obtain warranty service on items, you must return the product to an Authorized SHARK Dealer, freight prepaid, with proof of purchase, within the applicable warranty period. If the product is permanently installed, you must notify your Authorized SHARK Dealer of the defect. The Authorized Dealer will file a claim, which must subsequently verify the defect. In most cases, the part must be returned to SHARK freight prepaid with the claim. For warranty service on components warranted by other manufacturers, the Authorized Dealer can help you obtain warranty service through these manufacturers' local authorized service centers. If you are unable to resolve the warranty claim satisfactorily, write to SHARK at 4275 N.W. Pacific Rim Blvd., Camas, WA 98607, ATTN: Warranty Dept., detailing the nature of the defect, the name of the Authorized Dealer, and a copy of the purchase invoice.

LIMITATION OF LIABILITY

SHARK'S liability for special, incidental, or consequential damages is expressly disclaimed. In no event shall SHARK'S liability exceed the purchase price of the product in question. SHARK makes every effort to ensure that all illustrations and specifications are correct, however, these do not imply a warranty that the product is merchantable or fit for a particular purpose, or that the product will actually conform to the illustrations and specifications. **THE WARRANTY CONTAINED HEREIN IS IN LIEU OF ALL OTHER WARRANTIES, EXPRESS OR IMPLIED, INCLUDING ANY IMPLIED WARRANTY OF FITNESS FOR A PARTICULAR PURPOSE.** SHARK does not authorize any other party, including authorized Dealers, to make any representation or promise on behalf of SHARK, or to modify the terms, conditions, or limitations in any way. It is the buyer's responsibility to ensure that the installation and use of SHARK products conforms to local codes. While SHARK attempts to assure that its products meet national codes, it cannot be responsible for how the customer chooses to use or install the product.

SHARK PRESSURE WASHERS

4275 N.W. Pacific Rim Blvd. • Camas, WA 98607 • USA • 1-800-771-1881



4275 N.W. Pacific Rim Blvd. • Camas, WA 98607 • 1-800-771-1881

Form #97-6133 • Revised 1/03 • Printed in U.S.A.