

ACT **access control** **TECHNOLOGY**



**Operating & Installation Instructions for
ACT1000/2000 Access Control Units**

Contents

Default Code	1
Menu Navigation Keys	1
Text Entry Keys	1
Operator Menu	2
User Set-up	3
Enable	3
Disable	3
Assign Names	3
Assign Groups	3
Assign Options	3
Assign PINs	4
Learn	4
Batch Cards	4
One-To-One	5
Group Set-up	5
Enable	5
Disable	5
Assign Names	5
Access Rights	5
Assign Options	6
Assign PINs	6
System Log	6
Display Log	7
Print Log	7
Recommended Printer / Printer Settings	7
Filter Log (ACT2000 Only)	7
Control Door	8
Lock Door	8
Unlock Door	8
Normalise Door	8
Pass Door	8
AUX output on	8
AUX output off	8
User Tracking (ACT2000 Only)	8
Log in (ACT2000 Only)	8
Log out (ACT2000 Only)	8
Clear All (ACT2000 only)	9
Set Date/Time	9
Time Zones	9
Set Holidays	10
Issue Number	11
Change PIN	11
Installer Menu	12
System Settings	14
Operation	14
Display	14
PIN Length	14
Fire Doors	15
User Tracking (ACT2000 Only)	15
Outputs (ACT2000 Only)	15

Contents

Door Settings	16
Operation	16
Alarms	16
Timers	17
Timed Actions	17
Communications	17
Set Address	17
Direct Conn.	17
High Speed	18
Slave Mode (ACT2000 Only)	18
No Hist. Log	18
Print All	18
Remote Doors (ACT2000 Only)	18
Card Set-up	18
Site Code 1	19
Site Code 2	19
Card Format	19
Change PIN	19
Factory Default	19
Diagrams	20
ACT1000 Configuration Standalone	20
ACT2000 Configuration Standalone	21
DS100 Door Station Installation	22
Wiring for Entry / Exit Readers	23
ACT20 Pin Pad Installation Diagram	24
ACT1000/2000 PC / Printer and Modem Cables	25
Interlock Configuration	26
Fire Override Configuration	26
ACTWinPro Configuration	27
ACT 4-Line Network Wiring	28
ACT Single Line RS-485 Converter	29
ACT Modem Configuration	30
ACT LAN Configuration	31
ACT System Configuration	32

Operating Instructions for ACT1000/2000 Access Control Units

Software Version: 3.23-00

All user functions are accessed via two six-digit codes. The first code is for the *Operator* who is responsible for the day-to-day administration of the system, adding and deleting users, setting names and assigning time-zones etc. The second code is for the *Installer* who performs the initial configuration of the system and decides on communications settings, interfaces, and modes of operation.

Default Codes			
Operator	123456	Installer	999999

Menu System

All user functions are accessed via a menu system. The menu (or submenu) title appears on the top line of the display. The bottom line contains the current item in the menu. The three keys on the bottom row of the keypad are used for navigation:

Menu Navigation Keys		
✘ Quit to previous menu.	0 Next menu item	✓ Select item or Submenu

Text Entry

Textual descriptions (user names etc.) are entered via a simple text entry system. Each of the digits **1-9** may be used to enter letters, numbers or symbols according to the table below. Pressing the required digit once will bring up the first letter in that group. Subsequent presses will step through the group and then back to the first letter. Pressing the **0** key advances to the next character and pressing the **✘** key moves back to the previous character. The **✓** key accepts the currently displayed text. If the cursor is at the first location in the display, pressing the **✘** key gives the option to cancel all the displayed text.

Text Entry Keys					
1	a b c A B C 1	2	d e f D E F 2	3	g h i G H I 3
4	j k l J K L 4	5	m n o M N O 5	6	p q r P Q R 6
7	s t u v S T U V 7	8	w x y z W X Y Z 8	9	SPC - & . + ' / 9 0
✘	Previous Character	0	Next Character	✓	Accept displayed text

Operator Menu

User Setup	Enable	Allow a user or range of users to open the door
	Disable	Prevent a user or range of users from opening the door
	Assign Names	Enter a name for each user
	Assign Groups	Assign users to groups
	Assign Options	Specify options for each user
	Assign PINs	Set the individual PIN for each user
	Learn	Learn randomly coded cards (e.g. Bank Cards)
	Batch Cards	Assign a batch of cards to a range of users
	One-To-One Card Validity²	Assign a card to a user Set a validity period for a user.
Group Setup	Enable	Allow users in specified groups to open the door
	Disable	Prevent users in specified groups from opening the door
	Assign Names	Enter a name for each group
	Access Rights	Specify what access rights apply to each group
	Assign Options	Specify output and PIN options for each group
System Log	Assign PINs	Set the PIN for each Group.
	Display Log	Show the system log on the display (recent events first)
	Print Log	Print the system log on an attached serial printer
Control Door¹	Filter Log²	Prevent events entering the system log
	Lock Door	Lock door - prevent all cards from opening it.
	Unlock Door	Unlock door - relay is activated so cards are not required.
	Normalise Door	Set a door back to normal operation
	Pass Door	Momentarily open a door for the programmed time
User Tracking²	AUX output on	Switches the auxiliary output on
	AUX output off	Switches the auxiliary output off
	Log in	Log a user into the tracking area
Set Date/Time	Log out	Log a user out of the tracking area
	Clear All	Remove all users from the tracking area
Set Date/Time	Set the current date and time for the system	
Time Zones	Specify the time periods and days which apply to a given timezone	
Set Holidays	Specify which days within the next year are holidays	
Issue Number	Set the current system issue level (if issue checking option enabled)	
Change PIN	Change the PIN used to access the operator menu	

Exit from the menu is automatic if no keys are pressed for a period of time.

¹*On the ACT2000, you will first be prompted for a door.*

²*Only present on ACT2000*

User Setup

The *User Setup* menu allows the operator to enable and disable individual users, and to change the configuration information for each user. In each of the user setup functions, the user is selected by either using the **0** key to advance to the required user, or alternatively by using the numeric keys **1-9** to directly enter the number of the desired user. The top line of the display will show the name for each user if one has been entered, otherwise the number only will be displayed.

Enable

The *Enable* function allows a user or range of users to be enabled. Pressing the **✓** key enables the displayed user. This means that the card or token belonging to this user will be recognized and may be allowed entry to the protected area. Note that the group disable function or programmed access rights may override an enabled user.

Disable

The *Disable* function allows a user or range of users to be disabled. Pressing the **✓** key disables the displayed user. This means that the card or token belonging to this user will no longer be recognized and will not allow entry to the protected area.

Assign Names

The *Assign Names* function allows a 16 character textual name to be assigned to each user between 1 and 200/1000 (200 on the ACT1000, 1000 on the ACT2000). This name will be shown with any displayed or printed log events involving this user. Pressing the **✓** key selects text entry mode.

Assign Groups

The *Assign Groups* function allows a user or range of users between 1 and 1000/20000 to be assigned to one of up to 32 user groups. The user then inherits the options and time zones that are programmed for that group. By default, all users belong to Group 1. All users above 1000 on the ACT1000 always belong to Group 1 (unless programmed via ACTWinPro).

Assign Options

The *Assign Options* function allows additional options to be assigned to each user between 1 and 1000/20000. The available options are displayed in brackets in the form **[23T]** with non-assigned options displayed as a dash. Pressing the **✓** key allows the options to be altered. When changing options, the **0** key advances to each option, and the **✓** key selects or deselects the displayed option.

Option	Description
2	Activate O/P 2
3	Activate O/P 3
T	Toggle Relay

Note: The options assigned to an individual user operate in addition to those assigned to the group.

Assign PINs

The *Assign PINs* function allows a different PIN to be assigned to each of the first 1000/2000 users. Initially, the PIN will be **unset**. Pressing the ✓ key will prompt for the PIN for the displayed user to be entered (it will not be displayed). The PIN must then be re-entered for verification. The PIN will be accepted as long as it does not conflict with any existing PIN (or duress PIN). Entering all zeros will delete the PIN. The actual PIN is never shown on the display.

In *PIN Only* operation, this is the PIN that that user must enter to gain access. In this case, the PIN must be unique. In *PIN & Card* operation, this is the PIN that must be entered after the user has presented a card to the reader. If a PIN for a user is not set, then the relevant group PIN may be used instead (*PIN & Card* only).

Note that if learned cards are being used on the system, then individual user PINs are not permitted. In this case the relevant group PIN should be used instead.

Learn

In *Learn Mode*, any or all of the first 1000/2000 users may be allocated a randomly coded card in place of the usual site coded card. Any card with valid data on ISO Track 2 may be used. Certain types of wiegand cards may also be used.

Initially the display will show **Not Assigned** for the selected user indicating that the normal site-coded card should be used. Pressing the ✓ key prompts the user to select a door to learn from. After selecting a door, the user presents a card to the reader at that door. When the user presents the card to the reader, a unique 10-digit number generated from the data on the card is displayed. This card may then be used to gain access, and will replace any previously learned card.

Instead of presenting the card, the 10-digit number may be directly entered on the keyboard, if it is known in advance. Entering all zeros for the card number will revert to using the standard site-coded card for that user.

Learning cards is particularly useful for visitors who could, for example, use their personal bankcards to gain access for the duration of their visit.

Batch Cards

The *Batch Cards* function allows a sequential batch of cards to be assigned to a sequential range of users (e.g. card numbers 1001 to 1200 assigned from user 1 to user 200, where user 1 has card 1001). 50/100 batches may be programmed, each with a unique range of cards. Users may be assigned different cards in different batches if desired.

Initially, the display will show the batch as **Not Assigned**. Pressing the ✓ key prompts the user to select a door to read the cards from. The user must then present the first card in the batch to the reader at the selected door. When the user presents the first card to the reader, the card number is displayed. The user is then prompted to enter the last card in the batch. Instead of presenting the card, the 10-digit number may be directly entered on the keyboard, if it is known in advance. If the cards entered are already assigned to another batch, then the user is prompted to try again. The display will then request the user number to be assigned to the first card in the batch. Ensure that the user selected does not already have a card assigned.

The usual site coded cards are disabled if any batch cards are assigned on the system. However, site coded cards may be entered as a batch. Learned cards operate as normal.

One-To-One

In **One-To-One Mode**, any known card may be assigned to any of the first 1000/2000 users. If the site code and card number are known then they may be entered in from the keypad or the card may also be presented to a reader (similar to Learn Mode).

Card Validity (ACT 2000 Only)

The **Card Validity** menu allows any of the first 2000 users to be assigned a validity period. A user is considered invalid if the current date is not within the validity dates.

Group Setup

The **Group Setup** menu allows the operator to control how the system handles groups of users. A group may be enabled or disabled as a block, and may have options and timezones applied to the group as a whole. Users 1 to 1000/20000 may be assigned to any of the 32 groups. Users numbered above 1000 on the ACT1000 always belong to the first group (unless programmed in blocks of 100 via ACTWinPro). Group selection is the same as for users: the group is selected by either using the 0 key to advance to the required group, or alternatively by using the numeric keys **1-9** to directly enter the number of the desired group. The top line of the display will show the name for each group if one has been entered, otherwise the number only will be displayed.

Enable

The **Enable** function allows a group of users to be enabled. Pressing the ✓ key enables the displayed group. This means that the cards or tokens belonging to all users in the group will be recognized and will be allowed entry to the protected area provided that the individual users are also enabled.

Disable

The **Disable** function allows a group of users to be disabled. Pressing the ✓ key disables the displayed group. This means that the cards or tokens belonging to all the users in the group will no longer be recognized and will not be allowed entry to the protected area even if the individual users are enabled.

Assign Names

The **Assign Names** function allows a 16 character textual name to be assigned to each group. Pressing the ✓ key selects text entry mode. The group name is entered or deleted in exactly the same fashion as for individual user names.

Access Rights

The **Access Rights** function allows up to 8 timezone and door combinations to be specified for all users in a group. When a group is selected, the combinations will be displayed on the top line of the display in the form **ABCDEFGH + -**. The **0** key may be used to highlight one of these combinations and the bottom line of the display will show that timezone and door combination. Pressing the ✓ key allows the combination to be altered.

1) Select Group

Group 3
Timed Access

0 for next group
 ✓ to display access rights

2) Displaying access rights



A B C D E F G H + -
At all times
Selected Doors

0 for next combination
 ✓ to change combination

- 3) Changing timezone
- | |
|--------------|
| Timezone |
| At all times |
- 0 for next timezone
✓ to select
- 4) Changing door combination
- | |
|-------------------|
| Door 7 |
| ◀ [23---7---AB] ▶ |
- 0 for next door
✓ to select/deselect
✗ when done

In addition, **Full Access** or **No Access** may quickly be set for the group by highlighting and selecting the + or – symbols respectively:

- 5) Setting Full Access
- | |
|---------------------|
| A B C D E F G H + - |
| Full Access ? |
- ✓ to set full access
- 6) Setting No Access
- | |
|---------------------|
| A B C D E F G H + - |
| No Access ? |
- ✓ to set no access

Assign Options

The **Assign Options** function allows additional options to be assigned collectively to all users in the group. The assigned options are displayed in brackets in the form [23TXB] with non-assigned options displayed as a dash. Pressing the ✓ key allows the options to be altered. When changing options, the 0 key advances to each option, and the ✓ key selects or deselects the displayed option.

Option	Description
2	Activate O/P 2
The general-purpose output OP2 is activated for its programmed duration when users in this group are granted access.	
3	Activate O/P 3
The general-purpose output OP3 is activated for its programmed duration when users in this group are granted access.	
T	Toggle Relay
When the user is granted access, the relay is toggled so the door will remain permanently open until the next time the card or token is read.	
X	Auxiliary Door
On ACT1000 only, if the auxiliary door has been enabled, only groups with this option selected are allowed access.	
B	Track Bypass
On ACT2000 only, if tracking bypass is enabled, then users in this group are always allowed access through antipassback doors.	

Note: *The options assigned to an individual user operate in addition to those assigned to the group.*

Assign PINs

The **Assign PINs** function allows a different PIN to be assigned to each group of users. Initially, the PIN will be **unset**. Pressing the ✓ key will prompt for the PIN for the displayed group to be entered (it will not be displayed). The PIN must then be re-entered for verification. The PIN will be accepted as long as it does not conflict with any existing PIN (or duress PIN). The actual PIN is never shown on the display. If set, a PIN directly assigned to a user will take priority over this PIN.

System Log

The **System Log** menu allows the operator to view events in the historical event log, and to request a printout of the entire log.

Display Log

The **Display Log** function allows the operator to view events in the historical log directly on the LCD display. When this option is selected, the latest event in the log is displayed with the time and date on the top line of the display, and the event details being scrolled across the bottom line. Each log event will be displayed in turn (stepping backwards in time) until the end of the log is reached. Pressing the **0** key advances immediately to the previous event without waiting for it to be displayed. Pressing the **✓** key locks the current event on the display until **✓** is pressed again. Pressing the **✗** key exits from the display log function.

Print Log

The **Print Log** function allows the user to request the immediate printing of the entire system log on an attached serial printer. If real-time log printing is enabled, new events will be buffered until the complete log print is completed. Note that selection of this function only starts the log printing, and this may take a few minutes to complete. The display will indicate that printing has commenced, and return to the previous menu. If this function is re-selected before the log has been completely printed, then the option to stop the printout is given.

ACT Recommend the Epson LQ-300:

Wiring between Printer & Controller:	Controller	Printer
	0v TX RX	SERIAL (25 way connector)
	0V-----	PIN 7
	TX-----	PIN 3
	RX-----	PIN 20

Printer settings:

CHARACTER TABLE **PC850**
 PAGE LENGTH OF TRACTOR **11 INCHES**
 SKIP OVER PERFORATION **OFF**
 AUTO TEAR OFF **OFF**
 GRAPHIC PRINT DIRECTION **BI-D**
 SOFTWARE **ESC/P2**
 AGM **OFF**
 AUTO LINE FEED **OFF**
 INTERFACE **SERIAL**
 BIT RATE **9600BPS**
 PARITY BIT **NONE**
 DATA LENGTH **8 BITS**
 EXT/ACK **OFF**
 STATE REPLY **OFF**

Filter Log (ACT 2000 Only)

The **Filter Log** function allows the user to prevent certain events from being entered on the system log. Normally all events are logged, but to prevent ACTWinPro from having to store a lot of information on a large installation, some events may be filtered out.

The event types that can be filtered are access granted, access denied, alarms (mains fail, tamper etc.), door events (exit button pressed etc.) and others. The **0** key advances to each event type, and the **✓** key enables or disables the displayed event type.

The events may also be filtered out on certain doors. Normally all doors are allowed, but the user may prevent certain doors from reporting events.

Control Door

The *Control Door* menu allows the operator to control the door or externally connected equipment such as lighting or heating.

Lock Door

The *Lock Door* function causes the door relay to be de-energized. The bottom line of the display will show “Door Locked” and the red LED on the reader will flash. All subsequent cards will be rejected until the door is unlocked or returned to its normal state.

Unlock Door

The *Unlock Door* function causes the door relay to be energized. The bottom line of the display will show “Door Unlocked” and the green LED on the reader will flash.

Normalise Door

The *Normalise Door* function causes the door relay to be de-energized and the door to return to its normal state. The LED on the reader stops flashing and all subsequent operation will be the normal response to card activity.

Pass Door

The *Pass Door* function causes the door relay to be energized for the programmed period of time. This may be used to grant access to a person waiting outside the door.

AUX output on

The *AUX output on* function causes the auxiliary output relay to be energized. It will remain energized until the output is explicitly switched off. The output may be used to control externally connected equipment such as lights or heating.

AUX output off

The *AUX output off* function causes the auxiliary output relay to be de-energized. The output may be used to control externally connected equipment such as lights or heating.

User Tracking (ACT2000 Only)

The user tracking option allows the controller to remember which users are in or out of the defined area. If antipassback doors are assigned, then these define the tracking area. Users will not be allowed to re-enter the area until they have been recorded as exiting. The *Users Present output* and *User Limit A & B outputs* operate on the tracking area. If perimeter doors are assigned, then these define the area, however users may re-enter without restriction. If both are assigned, then the antipassback doors define the tracking area.

Log in (ACT2000 Only)

This function manually enters a user into the area. An event is logged for tracking. This is typically used when a user has forgotten their card. Manual login is not available if antipassback doors are defined – card access MUST be used.

Log out (ACT2000 Only)

This function manually removes a user from the area. An event is logged for tracking. This is typically used when a user has forgotten their card or when they have violated antipassback procedures and require entry.

Clear All (ACT2000 Only)

This function manually removes all users from the area. An event is logged for tracking. This is typically used at the end of a day or week to remove any users from the system who have neglected to use their cards when exiting.

Set Date/Time

The *Set Date/Time* function allows the operator to adjust the date and time on the controller's real-time clock. The built-in clock is normally accurate to within 60 seconds per month and will occasionally need adjusting to maintain the accuracy of logged events.

The display will prompt the user to enter the correct year (1996-2020), month (1-12), date (1-31), hour (0-23) and minute (0-59). The seconds will be zeroed. The prompt "Set?" is displayed on the bottom line of the LCD. The clock will not actually be updated until the ✓ key is pressed, allowing the operator to wait until the time is exactly correct. Any other key will exit without altering the time.

The day of the week calculation, millennium and leap year adjustments are made automatically by the controller's internal clock, even if power is not present. ACTWinPro automatically changes the controller time to match that of the PC. For Summer and Winter time changes, the controller must be connected to ACTWinPro.

Time Zones

A timezone is a combination of times for which some specified event should occur. For example, it may be used to determine when a group of users should be allowed access to the protected area. Typically, this is used to give different user groups varying degrees of access to the doors at different times of the day.

As an example: In a manufacturing environment, most production workers would be allowed access only on Monday to Thursday from 8.30 to 17.00, and on Friday from 8.30 to 15.00. This period would be set up in a timezone and assigned to most groups. Another category of worker might work different hours, so a second timezone could be set up for Monday to Friday from 17.00 to 19.30 and assigned to these groups, in addition to the previous timezone. Management would usually be granted 24 hour access, so a third timezone could be set up granting access from Sunday to Saturday (and holidays) from 00.00 to 23.59 and assigned to the management group. Note that there is a built-in 24-hour timezone that could be used instead.

Each timezone consists of up to five periods of time and a corresponding combination of assigned weekdays or holidays. The timezone is in force during the hours specified in any of the five time periods, but only on the days specified for that period.

The current timezone number will be displayed on the top line of the display. The desired timezone may be selected using the 0 key or directly by entering the timezone number. The lower line on the display will indicate if that timezone is active or inactive. Pressing the ✓ key allows the timezone to be edited. In edit mode, the top line of the display shows the available periods in the form ABCDE * -. The 0 key allows one of the five periods to be selected and pressing ✓ allows the period to be set.

- 1) Select Timezone

Timezone 3
Inactive

 0 for next timezone
 ✓ to edit timezone

 - 2) Select period

A B C D E + -
Week Days
08:30 -> 17:00

 0 for next period
 ✓ to edit period
-
- 3) Changing days/holidays

Wednesday
◀ [TWTF--1—4] ▶

 0 for next day/holiday
 ✓ to select/deselect
 ✗ when done

 - 4) Changing time period

Period
08:30 -> 17:00

 0-9 to set time
 ✓ for next minute/hour
 ✗ when done

In addition, the timezone may be assigned a name or all time periods cleared quickly by highlighting and selecting the * or – symbols respectively:

- 5) Assigning timezone name

A B C D E * -
Assign Name ?

 ✓ to assign name

- 6) Clearing a timezone

A B C D E * -
Clear ?

 ✓ to clear timezone

The assigned name will be displayed in place of **Timezone N** whenever the timezone is displayed or being selected from a list. In addition, there is a built in timezone “**24 Hours**” which is always active. There are 16 timezones available on the ACT1000 and 32 available on the ACT2000.

Set Holidays

The controller has a built in holiday scheduler that is used in conjunction with the operation of the timezones. When the scheduler is entered, the top line of the display shows the twelve months in the form **JFMAMJJASOND -**. A particular month may be selected by using the **0** key, and the **✓** key allows that month to be edited.

- 1) Select month

JFMAMJJASOND -
March

 0 for next month
 ✓ to edit month

- 2) Edit holiday

Wed 1 Mar 2000
Holiday 1

 0 for next day.
 ✓ to change holiday type
 ✗ when done

Any number of days within the next year may be tagged as being holidays. In effect, each holiday type is an extra day of the week, and will ensure that only timezones with the correct holiday types selected will be active.

Issue Number

This option allows the user to set the current system issue level to a number between zero (default) and 255. Only cards that have an issue number greater than or equal to the system issue level will be granted access. A card without an issue number encoded (Proximity, Wiegand, etc.) has an effective issue level of zero.

Issue numbering is intended for use in situations where all cards on the system are replaced on a regular basis. As an example, a health club might use its membership cards to allow the members access to different facilities. Towards the end of the year when members renew their subscription, they are given a new membership card with a higher issue number encoded on it. For a period of time, the old and new cards will both be granted access. At some point in the New Year, the system issue level is increased to the new level, leaving only paid up members with access. Life members could be given cards with an issue level of 255, which will always work.

Note: Issue numbering is usually only possible with standard ACT site-coded cards.

Change PIN

The Change PIN function allows a different PIN to be configured for the operator. The user will be prompted to enter a new six-digit code (it will not be displayed). The PIN must then be re-entered for verification. The PIN will be accepted as long as it does not conflict with any existing code (or duress code).

Installer Menu

System Settings	Operation	PIN Only	PIN's alone are used to gain access	
		Learn	Users 1-1/2000 may use random coded cards	
		Ext. Keypad¹	Use external ACT20 keypad	
		KPD Release¹	✓ Key is exit button.	
		Exit PIN's	Exit PIN's may be used in PIN only mode	
	Display	Second Door¹	Second (Auxiliary) door enabled on ACT1000	
		User Limiting²	Prevent access if the user limit is reached	
		One-To-One	Card numbers may be assigned to Users 1-1000/2000	
		Multiple	Users may have multiple cards	
		Backlight	Keypad backlight enabled	
PIN Length	Keypad Beep	Keypad beep enabled		
	Show Status	Display current status of doors on LCD		
	Show Events	Display events on LCD as they occur		
	Handshake	Use handshake line when printing		
	Tech Bleep²	Controller bleeps for technical fault		
Fire Doors	Perimeter	Define Perimeter doors		
	Antipassback	Define Antipassback doors		
	Tracking Reset	Set time for auto-reset (auto-logout)		
	User Limits	Set user limits A & B		
	Door 1	Define door 1 output special functions		
User Tracking²	Door 2	Define door 2 output special functions		
	Outputs²			
	Operation	Push Button	Door release button enabled	
	Door Settings*	Alarms	Lock Saver	Relay de-energized as door opens
			Chime	Buzzer sounds as door opens
Guest Button			Ⓐ on external keypad fires AUX/buzzer	
Exit Always			Timezones don't apply to exit readers	
Interlock			Only one door may be open at any time.	
Silent			Confirmation tones disabled	
Exit PIR			Door stays open while Push Button closed	
Failsafe			Door relay is normally energised	
Door Forced			Buzzer o/p active if door forced	
Door Ajar			Buzzer o/p active if door left ajar	
Duress Alarm	Buzzer o/p activated by duress code			
Door Open	Buzzer o/p active while door open			
Acc. Granted	Buzzer o/p when access granted			
Acc. Denied	Buzzer o/p when access denied			

¹ Feature present on ACT1000 only

² Feature present on ACT2000 only

* On ACT2000 you will first be required to select a door.

Door Settings* (contd.)	Timers	Relay Time OP2 Time OP3 Time Ajar Time AUX Time	Time for which relay is active Time for which OP2 is active Time for which OP3 is active Max time which door can be open Time for which AUX output is active	
	Reporting	Door Ajar Door Forced Door Open Door Closed Push Button Read Error	Buzzer o/p active if door left ajar Door Forced events report in log Door Open events report in log Door Closed events report in log Push Button events report in log Log and report reader errors	
	Timed Actions	Unlock Door Lock Door PIN Required Any Card Activate OP2 Activate OP3 Activate AUX PIN Only PIN or Card²	Specify times when door is unlocked Specify times when door is locked Specify times when PIN is required Specify times when any card gains access Specify times when OP2 is active Specify times when OP3 is active Specify times when AUX is active Specify times for PIN Only operation Specify times for PIN or Card operation	
	Assign Name		Assign a name to a door	
	Communications	Set Address		Set the network address of this door
		Direct Conn.		Specifies that this controller is connected directly to a PC
		High Speed		Sets the network communications speed to 19200 baud
		Slave Mode²		Specifies that this controller is a slave under ACT5000pc
		No Hist. Log		Disables the reporting of offline log events in slave mode.
		Print All		Enables real-time logging on attached serial printer
Card Setup	Remote Doors²		Enable/Disable remote doors connected via DS100 modules	
	Set Password		Set a password for remote communications	
	Site Code 1 Site Code 2 Card Format		Enter the primary site code for the system Enter a secondary site code for the system Enter a custom card format for the system	
Diagnostics	Version		Displays the current software version	
	Reader test		Reads a card and displays the received information.	
	Last Reset		Displays a code indicating the reason for the last reset.	
Change PIN			Change the PIN used to access the Installer menu	
Factory Defaults			Restore the system to its factory default settings.	

¹ Feature present on ACT1000 only

² Feature present on ACT2000 only

* On ACT2000 you will first be required to select a door.

Exit from menu is automatic if no keys are pressed for a period of time.

System Settings

The *System Settings* menu allows the installer to access a number of different configuration menus controlling different aspects of the setup of the controller. Pressing the ✓ key toggles the setting of a displayed option.

Operation

This menu allows the installer to select or de-select a number of options relating to the default operation of the controller.

- The *PIN Only* option allows reader-less operation using PIN codes that are directly entered on the keyboard (or on an external keypad). Up to 2000 codes may be used.
- The *Learn* option allows the first 2000 users to use randomly coded cards. Almost any card with valid ISO track 2 data may be used (for example bankcards) as well as some types of wiegand card.
- The *Ext. Keypad* option allows an external ACT20 keypad to be used for PIN entry on an ACT1000 controller. By default, the ACT1000's own keypad is used.
- The *KPD Release* option allows the ✓ key on an ACT1000 to function as an exit switch.
- The *Exit PIN's* option is applicable for ACT1000 PIN-only systems. When set, it requires PIN codes to be entered before the user is allowed to exit.
- The *Second Door* option allows an auxiliary door to be controlled on an ACT1000 unit.
- The *User Limiting* option will prevent access to tracked users when the user limit is reached.
- The *One-To-One* option allows any card number to be assigned to any of the first 1000/2000 users.
- The *Multiple* option allows users to have more than one card on the system.

Display

- The *Backlight* option forces the keypad to be permanently illuminated, overriding the default automatic operation, which is to operate only when a user menu has been entered.
- *Keypad Beep* option forces the keypad to make a short beep in response to any key being pressed. This option is selected by default.
- The *Show Status* option enables the displaying of continuous door status on the display. This option is enabled by default.
- The *Show Events* option enables the displaying of events on the display as they occur. This option is enabled by default.
- The *Handshake* option is used when a serial printer is connected. When selected, information will only be sent to the printer when a positive signal is applied to the RX pin on the printer port. This may be used to temporarily halt printing when the printer is disconnected or out of paper.
- The *Tech Bleep* option specifies that the ACT2000's onboard buzzer will sound intermittently if a technical fault (mains, tamper or door offline) condition exists.

PIN Length

The length of PIN codes used in PIN Only and PIN & Card modes may be set between 4 and 9 digits. If a PIN length greater than six is set, then the length of the operator and installer codes will increase to this length. (Leading zeros added to PIN).

Fire Doors

This function allows a group of doors (or all doors) to be configured for fire override. A 0Volt signal from a fire alarm (or other) system is applied to the **AUX input on door 1**. This maintains normal operation. When the 0Volt signal is removed, the selected doors are held open until the 0Volt signal is re-applied. Typically, a normally-closed relay on the fire panel, with the common connected to 0Volts, is used for this purpose (see the Fire Override diagram on page 26). Please note that this facility is present for convenience only, it does not remove the need to have an alternate mechanical means of escape.

User Tracking (ACT2000 Only)

- If **Perimeter** doors are defined, then the users are tracked but not restricted.
- If **Antipassback** doors are defined, then these define the tracking area (Perimeter doors are ignored). Users are allowed entry to the area only if they have previously exited.
- **Tracking Reset** is used to auto-reset (log all users out) at a specific time each day, or may be reset manually. In addition users may be individually logged in or out. This is recorded in the system log.
- Two **User Limits A & B** may be configured. These can be used to generate outputs when the number of users in the area reaches a certain level. This may be used for certain security critical areas. In addition an output may be configured to operate when any users are present within the area. This could be used to switch on or off certain equipment when the area is empty. The larger of the two limits is also used to determine how many tracked users to admit into the antipassback area. Once this limit is reached, access is denied to other tracked users. This could be used in a car-park application. User Limiting must be enabled for this to operate (see System Settings > Operation).

Outputs (ACT2000 Only)

The ACT2000 has 6 onboard outputs that can operate in addition to the local relay. These are the open collector outputs OP2 and OP3 (for doors 1 and 2) as well as the two auxiliary 1A relays. Normally these outputs function as for any door, according to the programmed user and/or door settings. However the onboard outputs on the ACT2000 may be given alternate functions as outlined below.

Door 1	AUX AUX Any Door	Auxiliary relay (1) activates when the auxiliary relay is activated for any door on the controller.
	OP2 Tech Fault	Open collector output OP2 (1) activates when a technical fault condition exists (tamper/mains fail/door offline).
	OP3 Any Door Open	Open collector output OP3 (1) activates when any door on the controller is open.

Door 2	AUX Users Present	Auxiliary relay (2) activates when one or more users are logged in to the system.
	OP2 User Limit A	Open collector output OP2 (1) deactivates when the number of users logged in is at or above User Limit A.
	OP3 User Limit B	Open collector output OP3 (1) deactivates when the number of users logged in is at or above User Limit B.

Door Settings

The **Door Settings** menu allows the installer to access a number of different configuration menus controlling different aspects of the selected door. The door for which the settings are to be changed is first selected using the **0** key, then the **✓** key is pressed to enter the menu.

The **0** key is used to select the required option or setting which is changed using the **✓** key.

Operation

This menu allows the installer to select or de-select a number of options relating to the default operation of the door.

- The **Push Button** option allows the relay to be activated when the external push-button contact is closed. This option is selected by default.
- The **Locksaver** (anti-tailgate) option truncates the relay timer when the door opens. This ensures that the door will be locked as soon as it closes even if a very long relay time is programmed. This also prevents overheating of the lock solenoid.
- The **Chime** option momentarily energizes the buzzer output whenever the door contact is seen to open. The onboard buzzer also makes a chime sound.
- The **Guest Button** option activates the buzzer output for 2 seconds when the **Ⓐ** key on an externally connected keypad is pressed (not applicable to Door Stations).
- The **Exit Always** option allows the holder of a valid enabled card to exit at all times irrespective of the configured timezones.
- The **Interlock** option prevents the door being opened when the AUX input is active. OP3 activates when the door is open or the door relay is active (see diagram page 26).
- The **Silent** option prevents the door buzzer from sounding when access is granted or denied.
- The **Exit PIR** option will keep the door open while the external push-button contact is closed. This allows a PIR to be used as the exit switch.
- The **Failsafe** option sets the door relay to be normally energised. This means that the door will open if the power supply to the controller fails.

Alarms

This menu allows the installer to enable or disable a number of alarm events that can be generated by the controller:

- The **Door Forced** alarm occurs when the door contact opens without the relay having been energized. The buzzer AUX output is activated until a valid card is presented.
- The **Door Ajar** alarm occurs when the door has remained open for longer than the duration programmed into the door ajar timer. The AUX output is activated while the door remains open.
- The **Duress** alarm occurs whenever a duress code is entered during Pin & Card operation. The duress code is the PIN code for that user with the last digit advanced by one.
- The **Door Open** alarm activates the AUX output whenever the door is open.
- The **Access Granted** alarm activates the AUX output for 2 seconds whenever a valid card is presented.
- The **Access Denied** alarm activates the AUX output for 2 seconds whenever an invalid card is presented.

Timers

The door timers menu allows the installer to program the time delays for the relay, AUX output, open collector outputs OP2 and OP3 and the door ajar alarm time. Each timer may be programmed with a duration from 1 to 999 seconds. The relay time may be programmed to 0 seconds, which will operate the relay for a quarter of a second approximately. This can be used for turnstile applications. Door Stations will support a maximum duration of 127 seconds.

Timed Actions

This Menu allows the user to set up a number of timed actions that are linked to timezones. Any combination of up to eight timezones may be assigned to an action. When any one of these timezones is in force, then the assigned action occurs for that duration.

Action	What Happens.
Unlock Door	For the duration of the assigned timezone, the door remains <i>unlocked</i> . The Green LED on the Reader will Flash
Lock Door	For the duration of the assigned timezone, the door remains <i>locked</i> . The Red LED on the Reader will Flash.
PIN Required	For the duration of the assigned timezone, a valid PIN code must be entered after any card is presented. This overrides any PIN required option that may be set for any group or user.
Any Card	For the duration of the assigned timezone, any card presented will be granted access as long as it contains Track 2 data, even if it would not normally be granted access.
Activate OP2	For the duration of the programmed timezone, the user programmable <i>output OP2</i> is active.
Activate OP3	For the duration of the programmed timezone, the user programmable <i>output OP3</i> is active.
Activate AUX	For the duration of the programmed timezone, the 1A auxiliary relay <i>output AUX</i> is active.
PIN Only	For the duration of the programmed timezone, the reader is disabled, and access is granted only by entering a valid PIN.
PIN or Card	For the duration of the programmed timezone, either a valid PIN or a valid Card will allow access.

Communications

This menu allows the installer to configure how the controller communicates with externally connected devices or over a network. It is used primarily to configure the communications mode or address of the unit, or to specify log printer options.

Set Address

This option allows the address of the controller to be set when it is operating in a networked system or when directly connected to a PC. The valid address may be from 1 to 255 and corresponds to the number of the controller as configured in ACTWinPro.

Direct Conn.

This option informs the controller that it is connected directly to a controlling PC, rather than via a network interface. In this mode of operation, only a single controller may be connected to the PC via a cable (max 30m) from one of the PC serial ports.

High Speed

Communications on the controller defaults to 9600 baud. The high speed option sets the controller to operate at 19200 baud. This option applies to direct connect to a PC, networked interface and printer modes of operation.

Slave Mode (ACT2000 Only)

This option selects slave mode operation as part of an ACT5000pc network. While the controller is switched into slave mode and all card events are transmitted to the network master for validation. The controller itself will not make any decisions on card events unless it is operating in fallback mode due to a network failure. This option is always set to No when using ACTWinPro.

No Hist. Log

This option suppresses the reporting of events occurring while offline *in slave mode only*. Normally when the controller is operating in slave mode, events are logged locally if the controller is offline, and are transmitted to the PC when communications are restored.

Print All

This option selects real-time printing to an attached serial printer. Each event is time stamped and printed immediately on the printer. Real-time printing will be temporarily suspended while a full log printout requested from the operator menu is in progress.

Remote Doors (ACT2000 Only)

This menu is where additional door stations or ACT1000 units are configured as extra doors on the ACT2000 controller. The new door (Door 3 to 16) is selected using the **0** key and the current status of the door is displayed on the bottom line of the LCD. The **✓** key may then be used to enable or disable the door:

- | | | |
|---------------------------------------|-------------------------------------|--|
| 1) To enable, select a Disabled door | Door 3
Disabled | 0 for next door
✓ to enable door |
| 2) To disable, select an Enabled door | Door 3
Door Normal | 0 for next door
✓ to disable door |

If a non-existent or incorrectly addressed door is enabled, the door will be polled for a short while, then the status will be displayed as **Door Offline**.

Set Password

A password consisting of a 10 digit number may be programmed into the controller to prevent unauthorized access from remote ACTWinPro users. Ensure this password matches the encryption key used by ACTWinPro.

Card Setup

The card setup menu is used to inform the controller which cards should be recognized by the system. Usually all that is required is to set the primary site code for the system. The site code is supplied along with any cards ordered, or can be obtained directly from ACT. In addition, a site code from another installation may be entered allowing shared access to the building. Where non-standard cards are being used, possibly from a previous access control or time & attendance system, the card format may be altered to accept these.

Site Code 1

This function allows the 8-digit site primary code for the system to be entered. The controller will recognize only cards with a matching site code. This code should also be quoted whenever additional cards or tags are being ordered for this installation. The factory default site-code is **10-2770-09**, which allows the use of the test card supplied with the controller.

Site Code 2

This function allows an 8-digit site secondary code for the system to be entered. In addition to the cards containing the primary site code, the controller will also recognize cards with this site code. In this case, an offset may also be specified – this is a value that is added to the card number of cards bearing the secondary site code, to prevent conflicts. If the secondary site code is not being used, it should be set to **00-0000-00**.

Card Format

- When “**Active**” is set to **YES**, the controller will recognize cards with a non-standard (custom) format. The card information must be encoded using ISO/ABA Track 2 format and may contain from 2 to 37 digits.
- When “**Check All**” is set to **YES**, the controller will *also* allow cards encoded with one of its standard built-in formats. This could be used (for example) in a transitional period while older legacy cards are being phased out.
- The **Length** field contains the total number of digits on the custom card. If this value is non-zero, then any card with a different number of digits will be rejected.
- The **Site** field allows the entry of the location of the starting digit of the site code field on the card. The length specifies how many digits are in the site code (1-5).
- The **Card** field allows the entry of the location of the starting digit of the card number field on the card. The length specifies how many digits are in the card number (1-5).
- The **Issue** field allows the entry of the location of the starting digit of the issue number field on the card. The length specifies how many digits are in the issue number (1-3). If issue numbering is not being used, then the start digit and length should be set to zero.

Change PIN

The *Change PIN* function allows a different PIN to be configured for the installer. The user will be prompted to enter a new six-digit code (it will not be displayed). The PIN must then be re-entered for verification. The PIN will be accepted as long as it does not conflict with any existing code (or duress code).

Factory Default

This function overwrites the controller’s non-volatile memory with the factory default settings. All user names, timezones, card enables, log information etc. are completely deleted so this function should be used with care.

It is always a good idea to factory default a new controller prior to initial configuration, or if the controller software has been changed or upgraded.



Typical ACT1000 Configuration (Standalone)

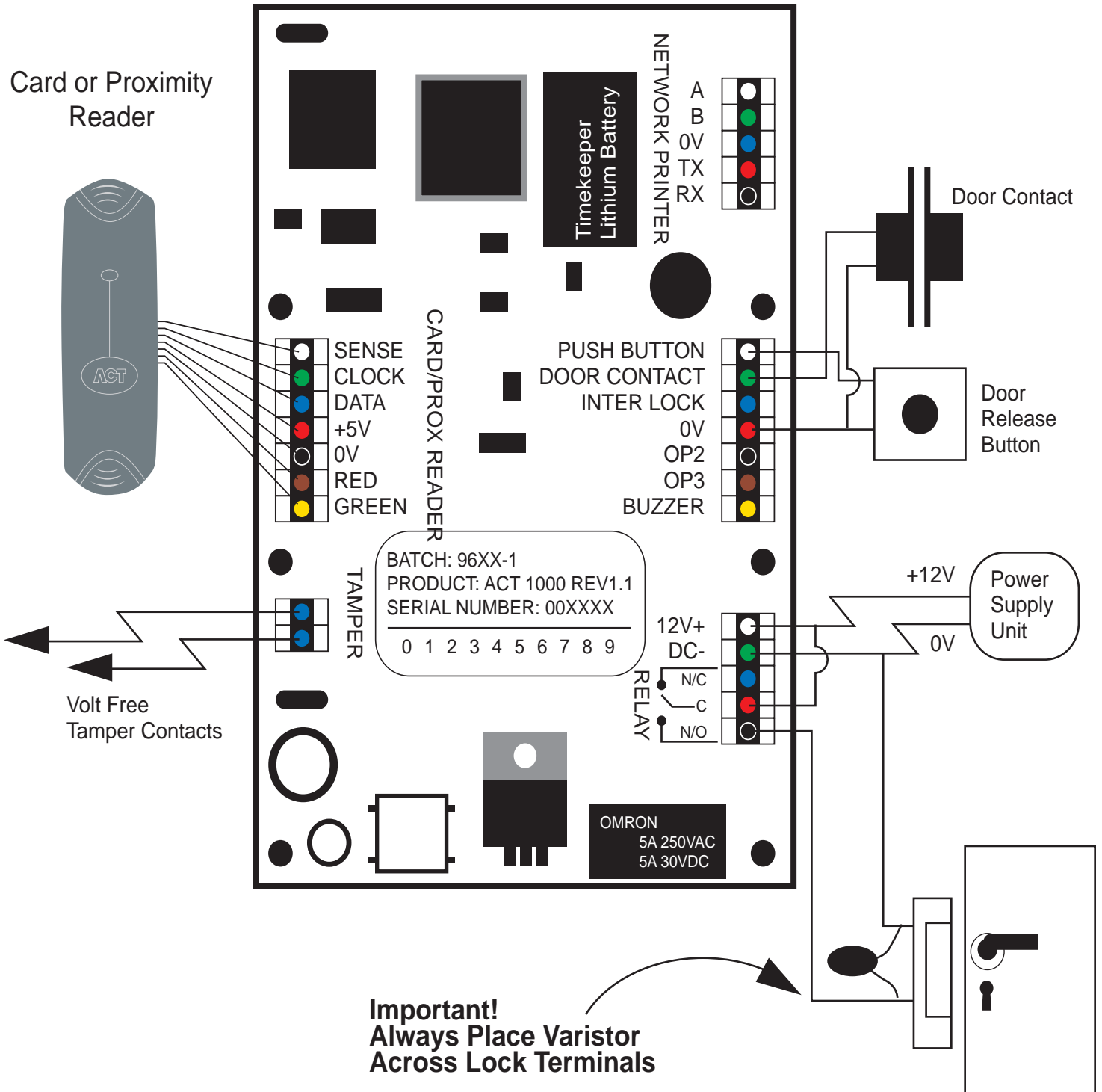



Typical ACT2000 Configuration (Standalone)

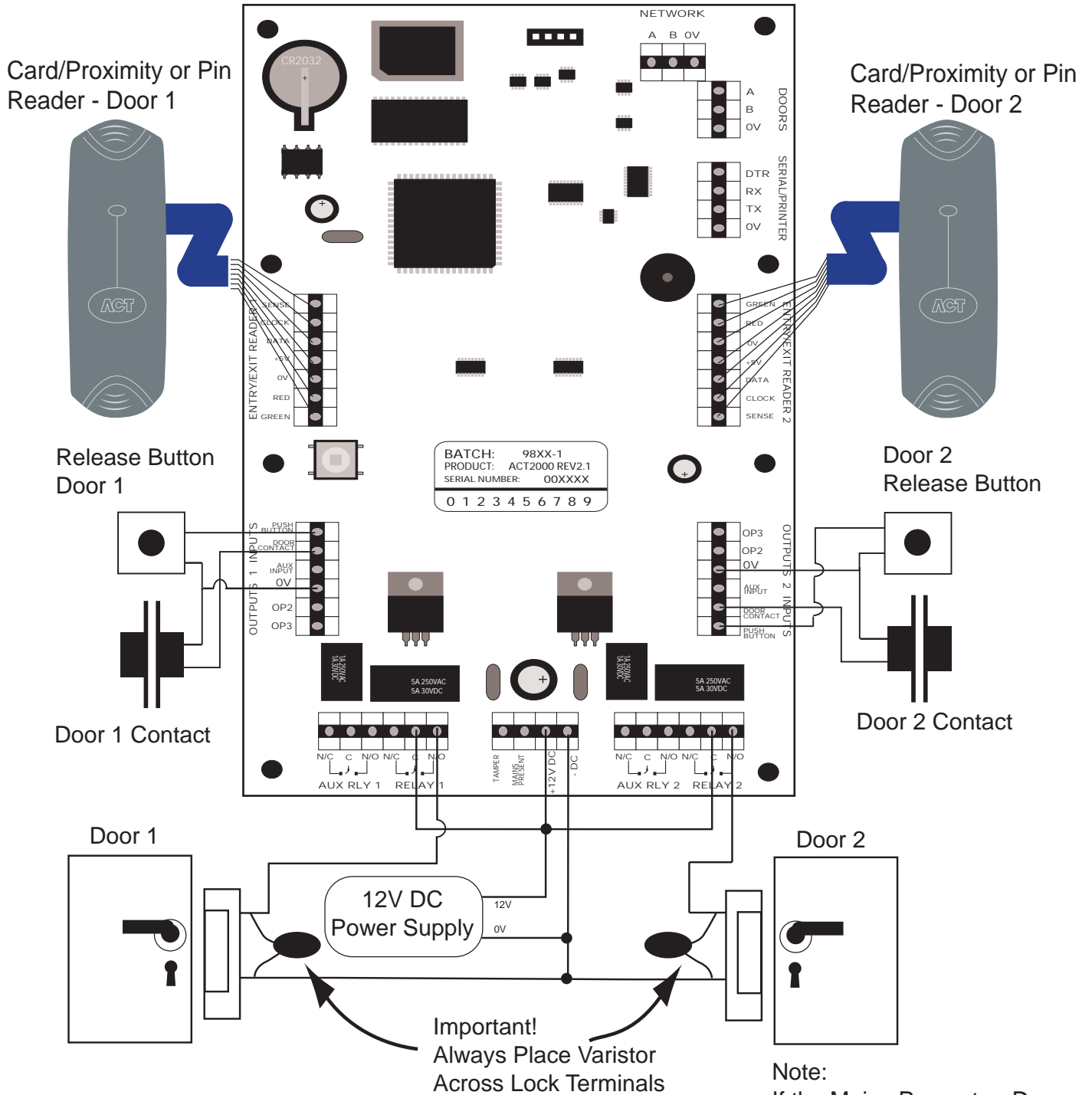

This illustration shows wiring for normally de-energised locks. If normally energised locks are required, use the N/C relay contacts.

Note:
If the Mains Present or Door Contact inputs are not used, they should be linked to 0V



DS100 Door Station Installation

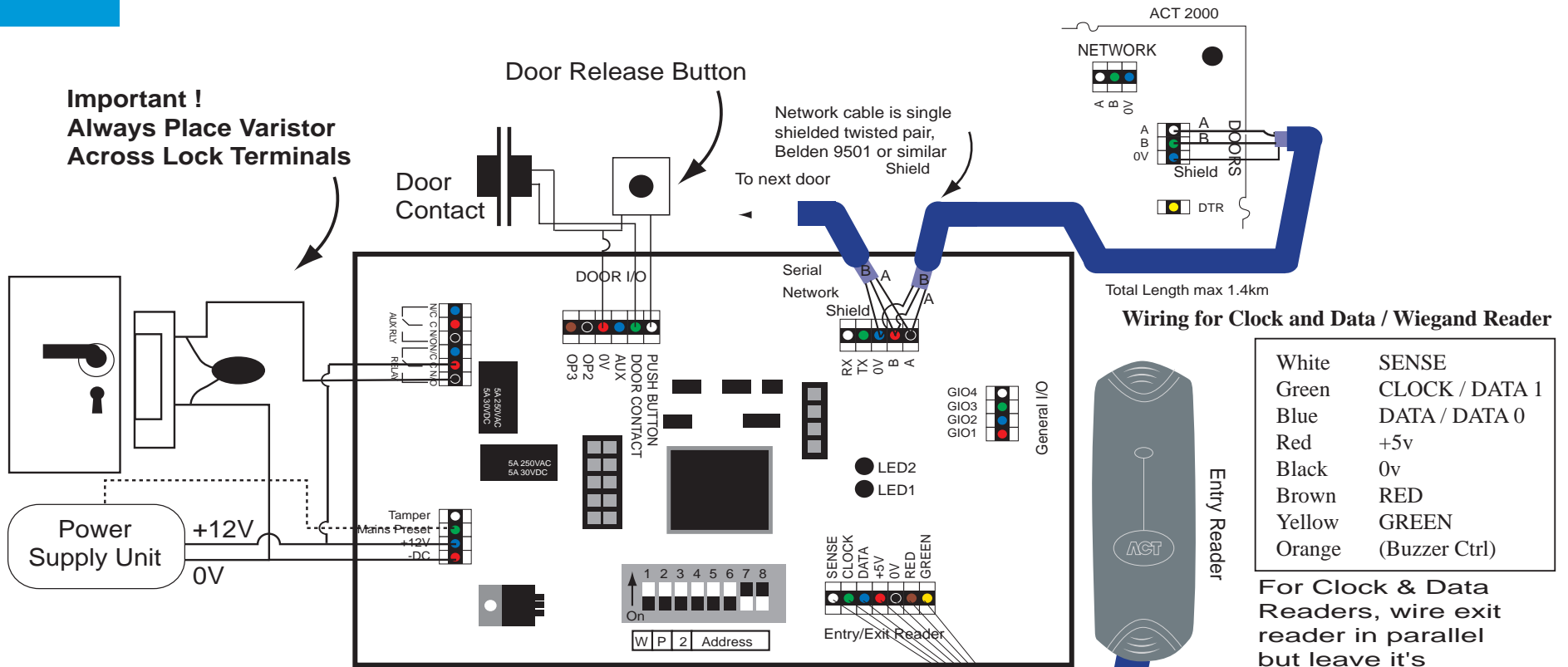

Wiring for Clock and Data / Wiegand Reader

White	SENSE
Green	CLOCK / DATA 1
Blue	DATA / DATA 0
Red	+5v
Black	0v
Brown	RED
Yellow	GREEN
Orange	(Buzzer Ctrl)

For Clock & Data Readers, wire exit reader in parallel but leave its sense line unconnected. For Wiegand Readers, wire the DATA 0 of the exit reader to SENSE on the DS100

Note:
If the Mains Present or Door Contact inputs are not used, they should be linked to 0V

This illustration shows wiring for a normally de-energised lock. If a normally energised lock is required, use the N/C relay contacts.

For PIN only operation, set switch 2 to the ON position

To set the door number, set address switches 4-8 as shown

Required Address	4	5	6	7	8
03	OFF	OFF	OFF	ON	ON
04	OFF	OFF	ON	OFF	OFF
05	OFF	OFF	ON	OFF	ON
06	OFF	OFF	ON	ON	OFF
07	OFF	OFF	ON	ON	ON
08	OFF	ON	OFF	OFF	OFF
09	OFF	ON	OFF	OFF	ON

Required Address	4	5	6	7	8
10	OFF	ON	OFF	ON	OFF
11	OFF	ON	OFF	ON	ON
12	OFF	ON	ON	OFF	OFF
13	OFF	ON	ON	OFF	ON
14	OFF	ON	ON	ON	OFF
15	OFF	ON	ON	ON	ON
16	ON	OFF	OFF	OFF	OFF

FACTORY DEFAULT
This unit should be reset to its factory default condition before installation. To do this, power the unit up with ALL switches in the OFF position. The two LED's will illuminate for about 2 sec. The correct switch settings may then be set.



Wiring for Entry/Exit Readers

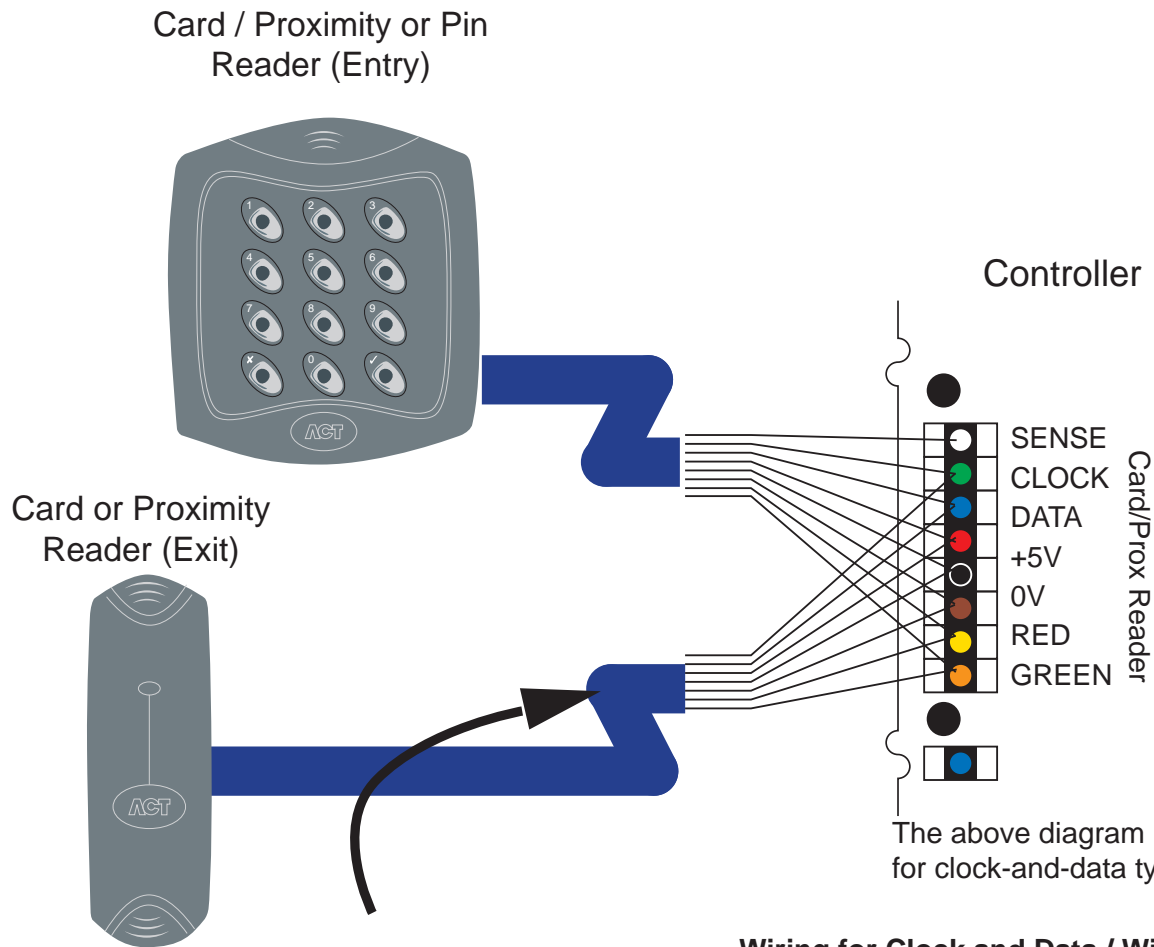

Wire both readers in parallel but leave the SENSE line on the Exit reader unconnected.

For Wiegand Exit readers

Connect DATA 0 of the exit reader to SENSE on the controller. Leave SENSE on the *readers* unconnected.

Wiring for Clock and Data / Wiegand Reader

White	SENSE
Green	CLOCK (DATA 1)
Blue	DATA (DATA 0)
Red	+5v
Black	0v
Brown	RD
Yellow	GREEN
Orange	(Buzzer Control)

The standard wiring colours for ACTPro Proximity and Pin readers is shown above. Readers may be a maximum of 30m from the controller when powered from +5V and a maximum of 100m when powered from +12V.

The +5V reader supply on ACT controllers is normally rated at 100mA. Typically this is sufficient to power 2 ACT readers. Note however that readers from other manufacturers may need to be powered separately if their current requirements exceed this or if they require 12V.



ACT20 PIN Pad Installation Diagram

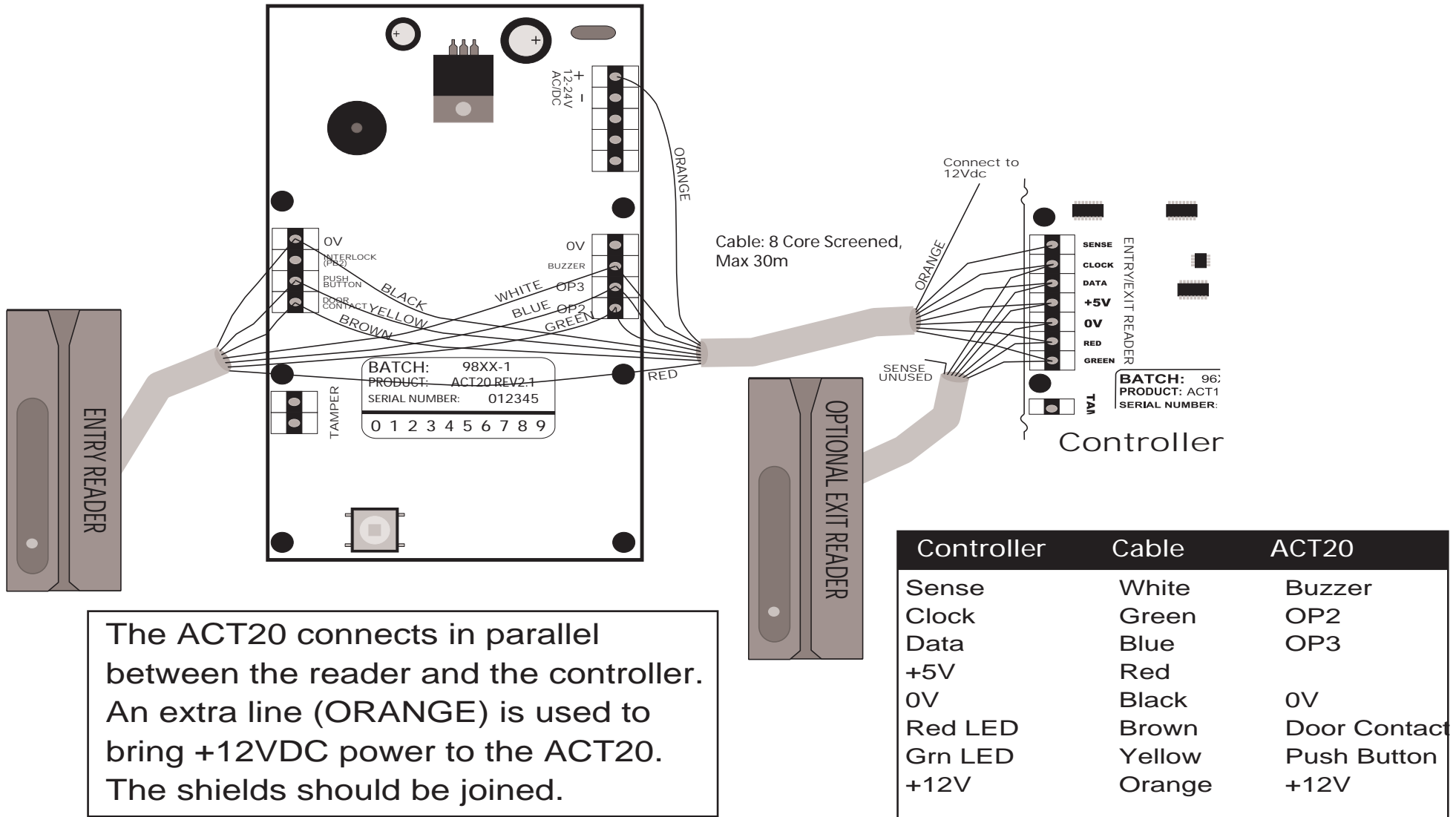



ACT1000/2000 Cable Connections

Direct Connection Cable (PC to Controller)

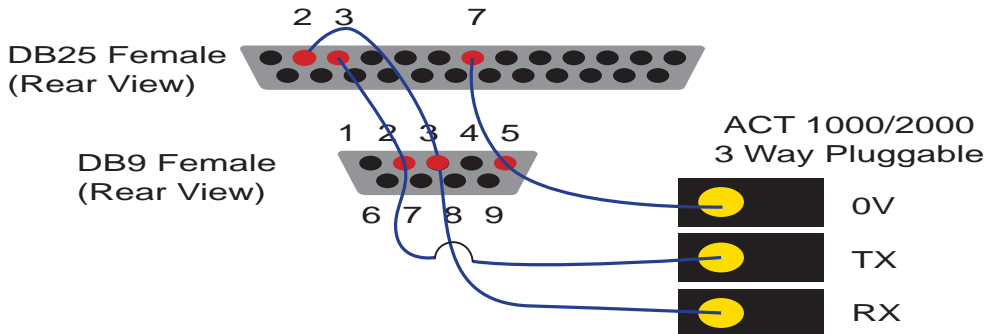

Max cable length is 5m using standard alarm cable or 30m using twin twisted-pair (use 0V in each pair)

Serial Printer Cable

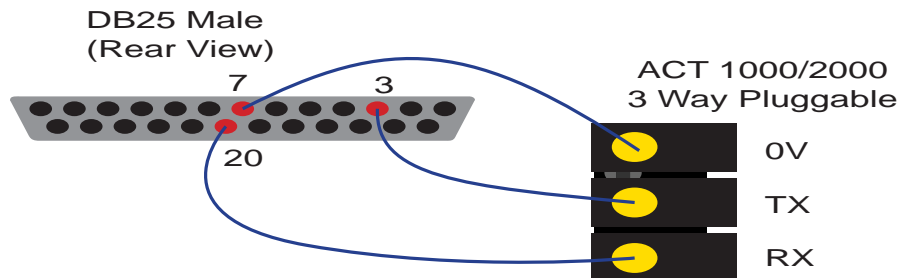

Max cable length is 5m using standard alarm cable or 30m using twin twisted-pair (use 0V in each pair)

Serial Modem Cable (Modem to Controller)

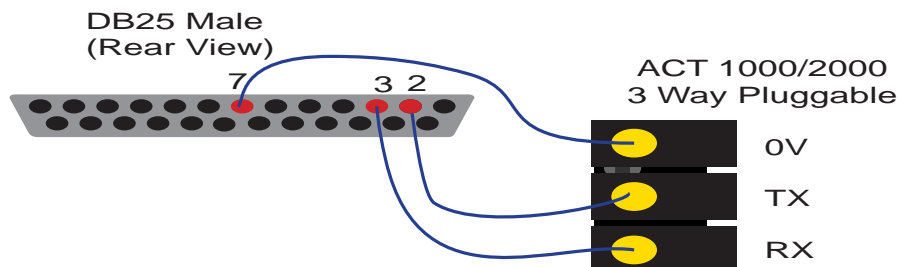

Max cable length is 5m using standard alarm cable or 30m using twin twisted-pair (use 0V in each pair)



ACTWinPro Configuration

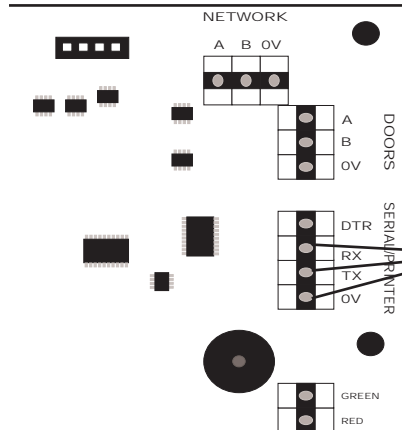

ACT2000

Direct Connect Cable

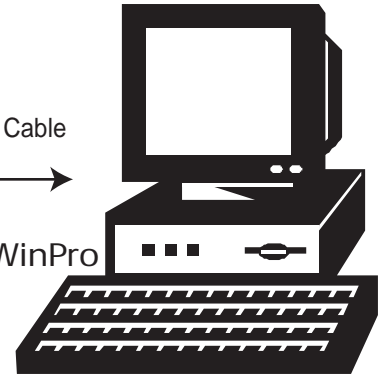

ACTWinPro

From the Installer Menu, do the following:

1. Factory Default the controller.
2. Go to the Communications menu and Set Address. If there is only 1 controller, set the address to 1. For more than 1, assign each controller a unique address, starting at 1.
3. Set Direct Connect to Yes if the PC is connected directly to one controller (as shown above). Set to No if it is a networked system. For more than one controller, an RS-485 Network Interface is required.
4. Connect the controller(s) to the PC.
5. From ACTWinPro, configure a new database.
6. Follow the database creation wizard.
7. Ensure that Comms is set up correctly.
8. Connect to the controllers.

Click here to Connect

Location Number: 1

Location Name: Head Office

Type of Connection: Serial port

Comms Host PC name: \WJOHN (this PC)

Location status: Refresh

Comms Details:

- RS232 Direct Connection
- RS485 Network - 4 Line Interface
- RS485 Network - Automatic Interface

Port: COM1 Speed: Normal - 9600 bps

Dial-up Modem: Use any available modem!

TCP/IP Details:

IP Protocol: TCP session

IP Port #:

Security:

Encryption Key: 0

Generate

Click here to configure Comms

Select if Direct Connect or Networked

Select COM port and Speed

Select if Serial Port or Modem or TCP/IP Connection



ACT 4-Line Network Wiring

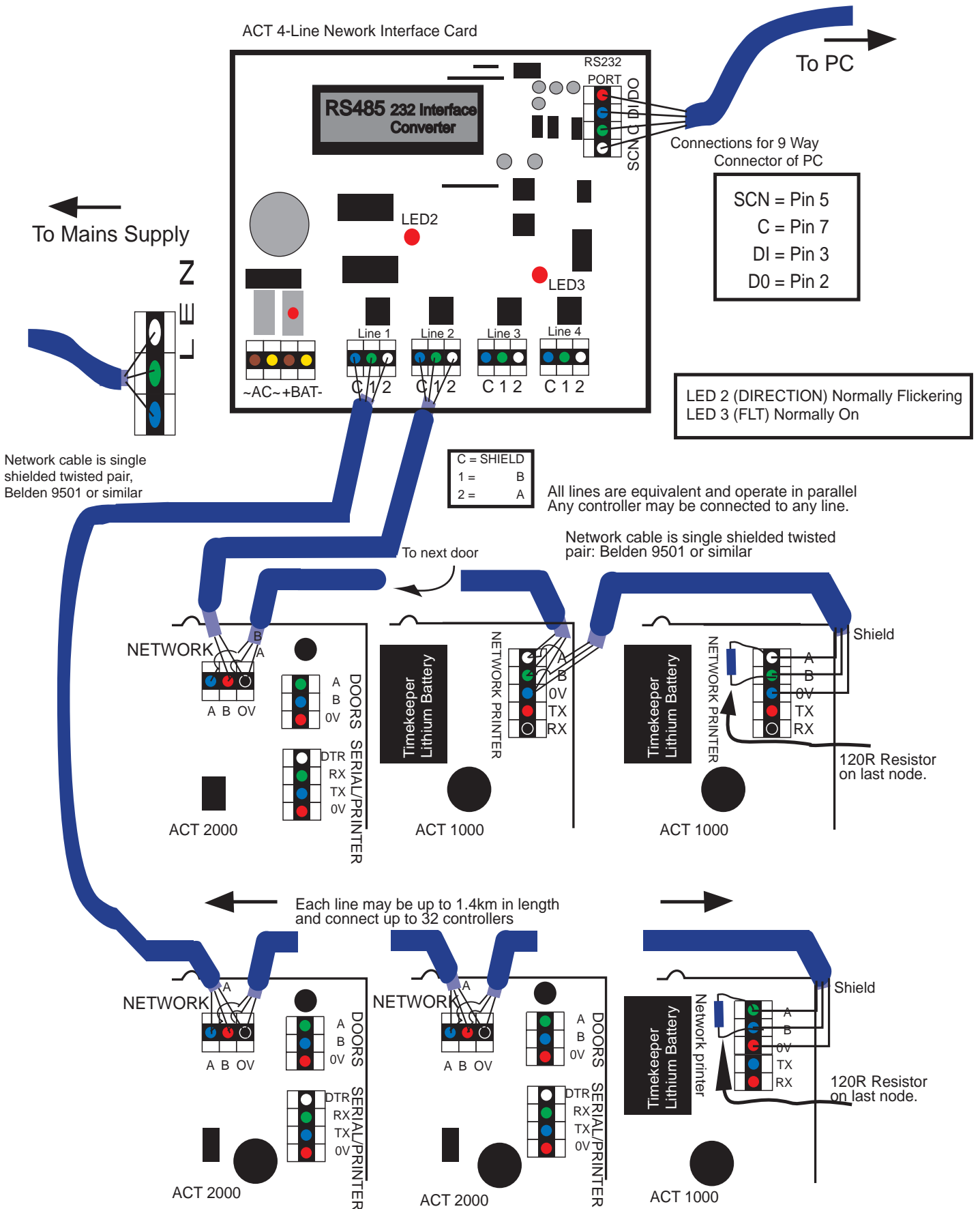



ACT Single Line RS-485 Converter

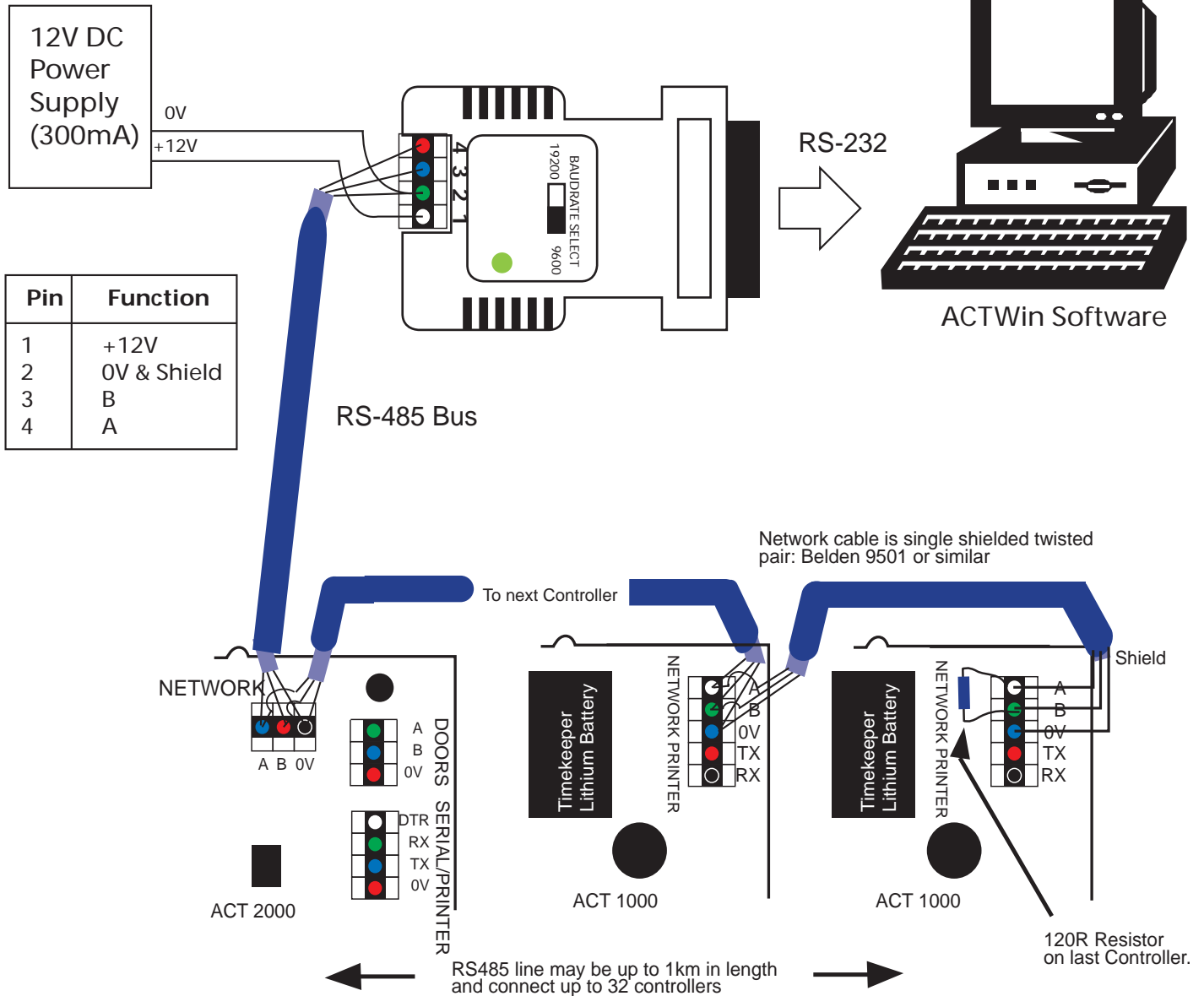

Setup for Network Operation

1. From the Controller keypad Enter Installer Menu->Communications and set a unique address for each controller on the network. Set Direct Connect to No.
2. From ACTWinPro create a new database. In the database creation wizard check RS-485 Automatic Interface.
3. Connect to the controllers from ACTWinPro. The LED on the RS485 converter should blink rapidly indicating communications in progress.

ACT Modem Configuration

Direct Connection from Modem to Controller

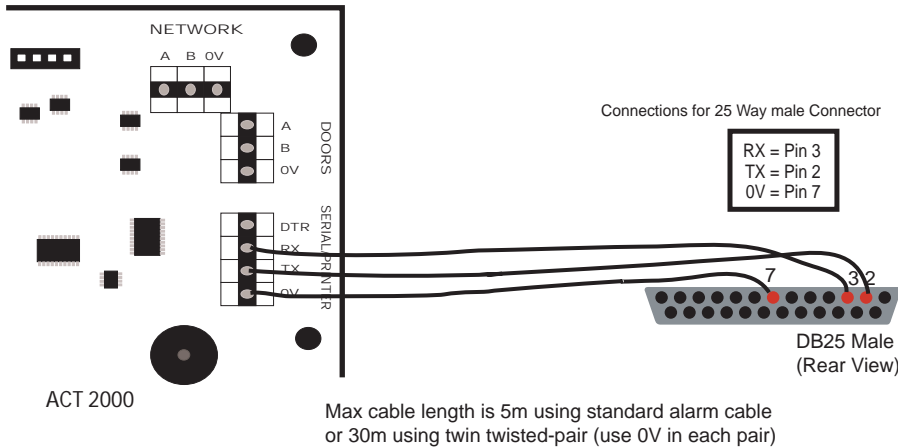

1. Connect Modem Cable directly to ACT1000/2000 and Modem
2. In Communications Menu Set:
Address = 1
Direct Conn = Y
3. Controller is now ready to receive calls

Modem Connection for ACT Network

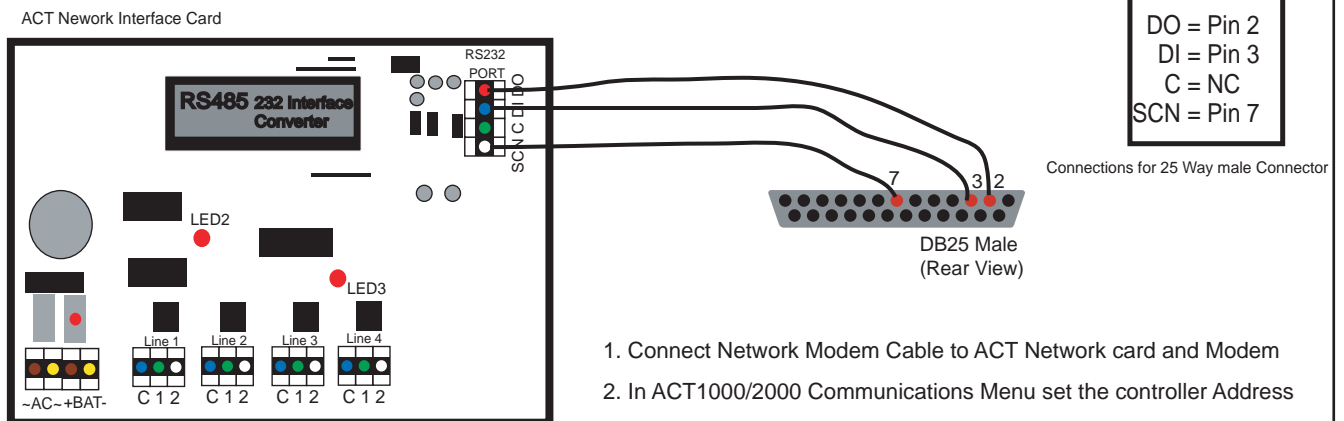

1. Connect Network Modem Cable to ACT Network card and Modem
2. In ACT1000/2000 Communications Menu set the controller Address and set Direct Conn = N
3. Controller(s) now ready to receive calls

ACTWinPro Setup for Modem Operation

1. Connect the ACT modem to the PC and install modem driver.
2. In ACTWinPro, Click on the *Locations and Connections* icon on the toolbar.
3. Configure the remote site name in the *Location Name*.
4. Select the *Type of Connection* as Modem.
5. Enter the remote sites' telephone number.
6. Select the newly installed modem as the *Dialup Modem*.
7. Set up remote controller(s) in the *Controller View*. Set the location as the remote site name.
6. The controller(s) will appear under the remote site name in the *System View* window.
7. Double click on the telephone icon beside the remote site name in *System View* window.
8. Modem will now contact remote Site and connect to the controller(s).
9. To finish the call, click the disconnect button on ACTWinPro



ACTLAN Configuration Diagram

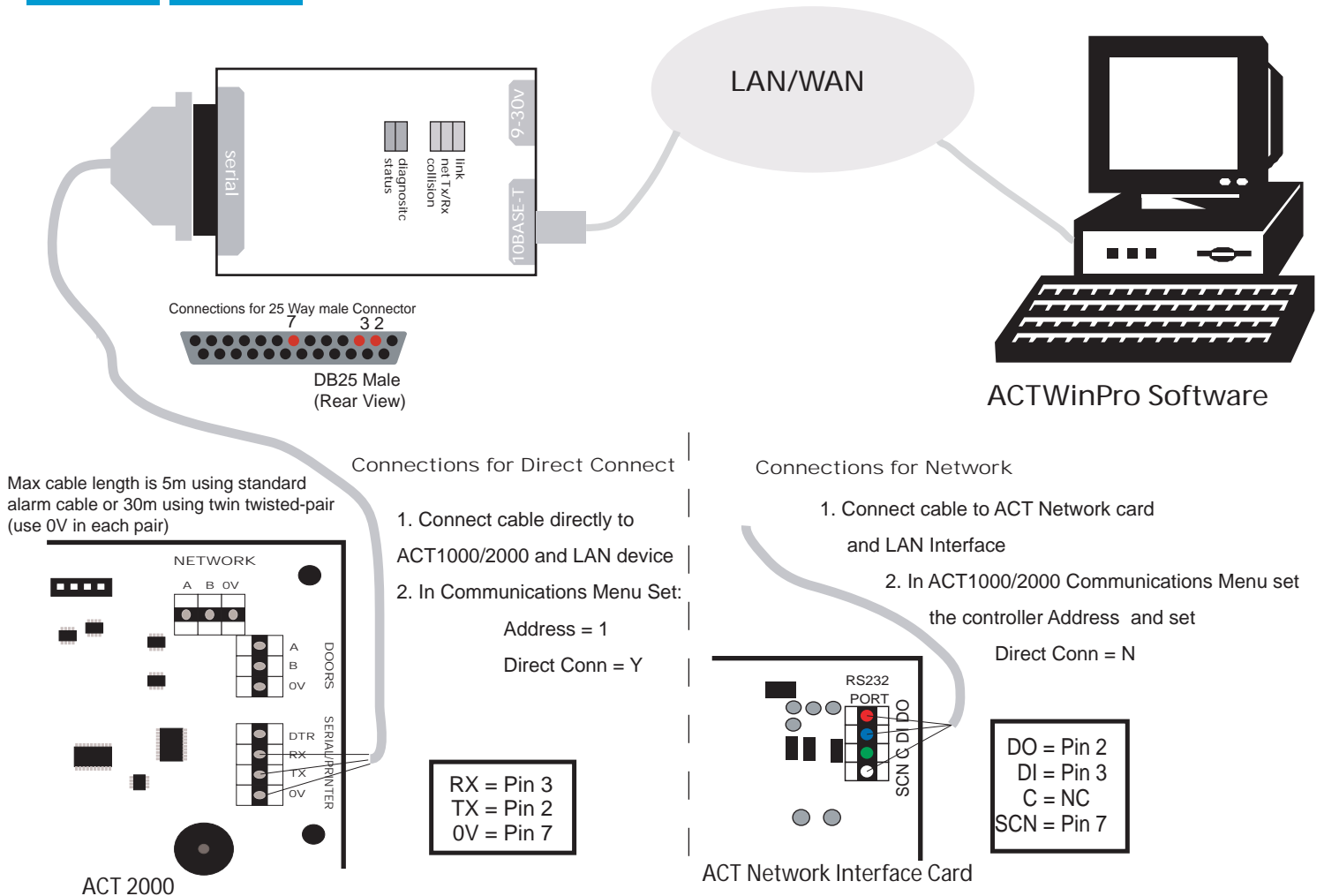

TCP/IP Configuration

1. Ask the network administrator to supply you with a permanent IP network address.
2. Connect a PC directly to the ACTLAN and run HyperTerminal at 9600 baud, no parity, 1 stop.
3. Power up the ACTLAN and **immediately** hit 3 lowercase "x" (xxx).
4. Hit the Enter key to go into Setup Mode.
5. Select 0 and follow the prompts until you get to IP address.
6. Enter the new IP address.
7. Follow the prompts to come back to the Setup Menu.
8. Select 1 to configure the RS232 channel.
9. Set up the following parameters as follows:

Baud Rate	9600	I/F Mode	4C
Flow	00	Port	10001
Connect Mode	C0	Disconnect Mode	00
Flush Mode	80	Pack Control	00
Remote IP Address	none		
10. Return to the Setup Menu and select 9 to save the settings.
11. Finally test the setup by connecting to the IP address using a Web browser.
12. From ACTWinPro, click the Locations and Connections icon in the toolbar. Select TCP/IP Network as Type of Connection and enter the IP address. The Port number should be 10001.



ACT System Diagram

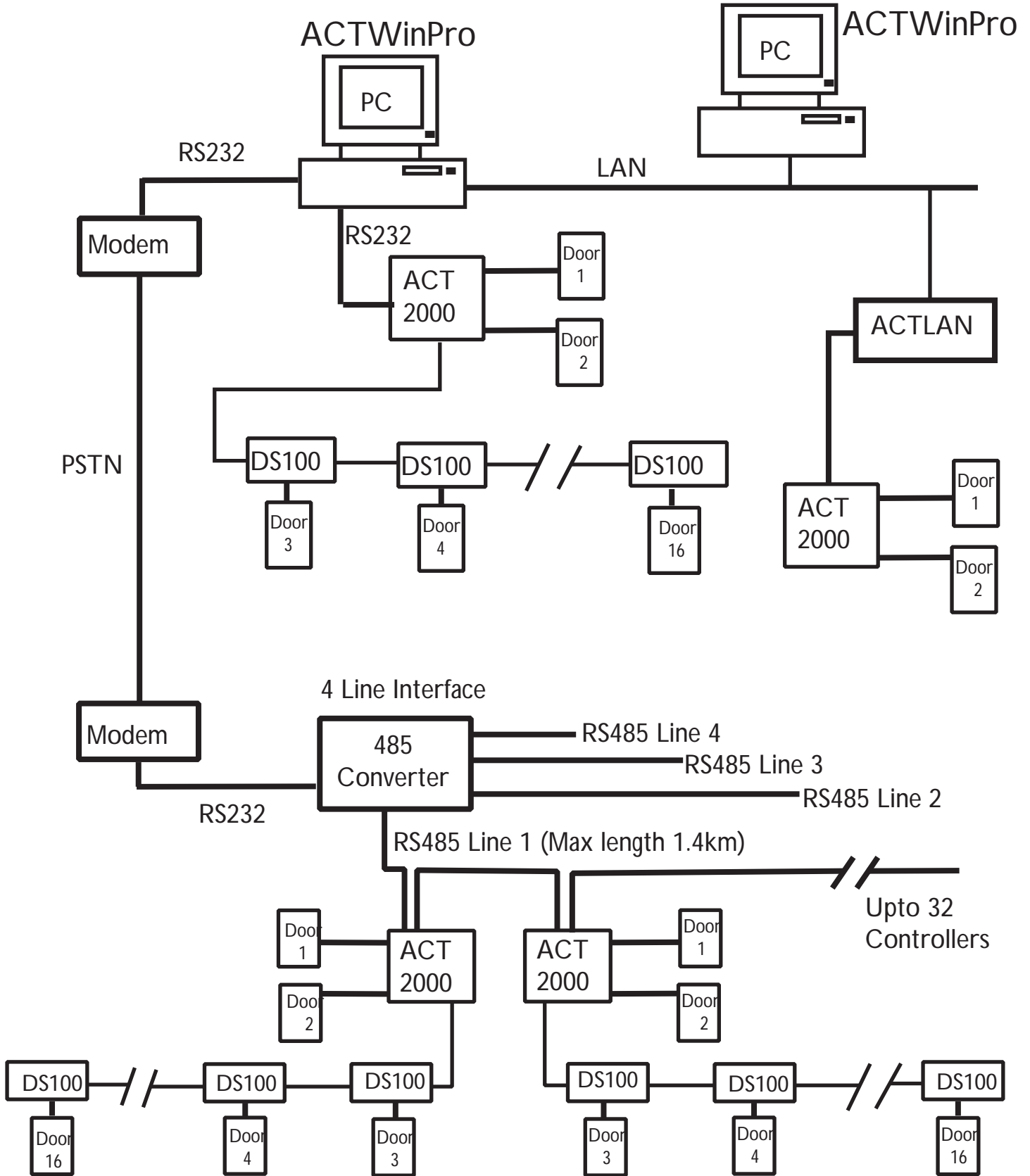

System Diagram:

Illustrating some of the ways to connect ACT Controllers to a computer.