

OWNER'S MANUAL

ELECTRIC STERILMATIC STERILIZER

MODELS: STM-E
 STM-EL

EXPORT MODELS: STM-EX
 STM-ELX

- **INSTALLATION**
- **OPERATION**
- **MAINTENANCE**
- **TROUBLE-SHOOTING**
- **PARTS & SERVICE**
- **WARRANTY**



TABLE OF CONTENTS

SECTION 1 INSTALLATION INSTRUCTIONS

SERVICE & TECHNICAL INFORMATION CONTACT	1
OPERATION ENVIRONMENTAL CONDITIONS	1
INTENDED USE - DUTY CYCLE	1
INSTALLATION	1
ELECTRICAL	1
OUTSIDE VENTING	1
WATER-COOLED EXHAUST CONDENSER	1
RECORDING THERMOMETER	1
TRAY SUPPORTS	1
BAFFLE INSTALLATION	1
OPERATION CHECK	1
INSTALLATION INSTRUCTIONS FOR COLD WATER CONDENSER	2
REQUIRED CONNECTIONS	3
INSTALLING PAN SUPPORTS AND BAFFLES	4
ELECTRICAL SUPPLY CONNECTIONS FOR STM-E & STM-EL	4
ELECTRICAL SUPPLY CONNECTIONS FOR STM-EX & STM-ELX	4
DOMESTIC WIRE DIAGRAM FOR STM-E & STM-EL ...	5
EXPORT WIRE DIAGRAM FOR STM-EX & STM-ELX	6
TYPICAL CIRCUIT CONNECTION FOR STM-E & STM-EL	7
TYPICAL CIRCUIT CONNECTION FOR STM-EX & STM-ELX EXPORT	8
INSTALLATION FOR OPTIONAL RECORDING THERMOMETER	9
TO REMOVE THE CHART	9
TO INSTALL NEW CHART	9
THERMOMETER DIMENSIONS.....	10
REPLACEMENT PARTS FOR 24 HOUR THERMOMETER	10

SECTION 2 WATER CONDITIONS 11

SECTION 3 OPERATING INSTRUCTIONS

OPERATING INSTRUCTIONS	11
STERILIZATION GUIDE	12
MINIMUM STERILIZATION TIMES	12

SECTION 4 MAINTENANCE

DAILY CLEANING PROCEDURE	13
--------------------------------	----

SECTION 5 FIELD SERVICE INSTRUCTIONS & ASSEMBLY

STERILMATIC OPEN STAND	14
PARTS LIST FOR CONDENSER WITH OPTIONAL STAND	14
DOOR ADJUSTMENT	14
STERILMATIC DOOR ASSEMBLY	15

DOOR ASSEMBLY PARTS LIST	15
THE DOOR GASKET	15
DOOR LIFT SPRING	15
TO REMOVE THE DOOR ASSEMBLY	15
THE FULCRUM AND DRAIN ASSEMBLY	16
ROLLER ASSEMBLY	16
FULCRUM AND DRAIN PARTS LIST	16
DOMESTIC – THE PRESSURE ACTUATED TEMPERATURE CONTROL, STM-E & STM-EL	17
DOMESTIC – HOW IT WORKS	17
DOMESTIC – ADJUSTING THE RANGE OF OPERATION, STM-E	17
EXPORT - THE PRESSURE ACTUATED TEMPERATURE CONTROL, STM-EX & STM-ELX	17
EXPORT – HOW IT WORKS	17
EXPORT – CHECKING THE 100°C SETTING, STM-ELX	17
EXPORT – ADJUSTING THE RANGE OF OPERATION, STM-ELX	18
DOMESTIC – CHECKING THE 230° SETTING, STM-EL	18
DOMESTIC – ADJUSTING THE RANGE OF OPERATION, STM-EL	18
CAST-IN THE HEATING ELEMENTS	18
THE LOW WATER CUT-OFF (<i>MANUAL RESET</i>)	18
THE ELECTRIC CONTACTORS	18
THE TIMER	18
THE STEAM PRESSURE GAUGE	19
THE SAFETY VALVE	19
THE FLUE	19
THE EXHAUST SOLENOID VALVE	19
TO REPLACE A THERMOSTATIC ELEMENT	19
THE STEAM TRAP	19
HOW IT WORKS	19

SECTION 6 ILLUSTRATED PARTS

PARTS ILLUSTRATION FOR STM-E(L) & STM-E(L)X	20
& 21	
PARTS ILLUSTRATION FOR STM-E & STM-EX	22
PARTS ILLUSTRATION FOR ALL MODELS	23
& 24	
CONTROL PANELS	25
DOOR HANDLE	26
& 27	
MISCELLANEOUS PARTS (NOT SHOWN)	28

SECTION 7 TROUBLE SHOOTING

STEAM TRAP TROUBLE-SHOOTING	29
TROUBLE-SHOOTING GUIDE	29

SECTION 8 WARRANTY INFORMATION 30

SECTION 1 INSTALLATION INSTRUCTIONS

AUTOMATIC STERILMATIC STEAM PRESSURE STERILIZER

MODELS: STM-E, STM-EL, STM-EX & STM-ELX

SERVICE & TECHNICAL INFORMATION CONTACT

NOTE: This unit should be serviced by qualified service personnel only.

Your Sterilmatic Sterilizer has been developed to answer the need for a compact, automatic, low-cost steam pressure sterilizer. The following instructions cover installation. Should service be required, it is readily available by contacting our authorized service agency located nearest to you. The name of your local service company can be obtained by contacting the Service Department at Market Forge., Telephone (617) 387-4100 or via e-mail custserv@mfi.com.

OPERATING ENVIRONMENTAL CONDITIONS

This unit is designed for commercial use and to be safe at least under the following conditions:

- For indoor use only.
- For use at altitudes up to 6500ft (2000m)
- For use at temperatures from 41°F (5°C) to 104°F (40°C).
- Maximum relative humidity 80% for temperatures up to 88°F (31°C) decreasing linearly to 50% relative humidity at 104°F (40°C).
- Main supply voltage fluctuations not to exceed ± 10% of nominal voltage.
- Transient overvoltages according to Installation Categories II (in accordance with IEC 664).
- Pollution Degree 2 (in accordance with IEC 664).

INTENDED USE - DUTY CYCLE

This unit is intended to be operated intermittently. After a pre-heat cycle, the longest period of use is 60 minutes. The timer allows a maximum of 60 minutes. After each use the unit should be opened for removal and reloading of product. The water level should be checked after each use and re-filled when necessary.

INSTALLATION

Set sterilizer on counter, using the 6" (152mm) legs provided or assemble the optional stainless steel stand with under-shelf. If your Sterilmatic includes a water-cooled exhaust condenser, we recommend the use of the Sterilmatic stand, part number 95-6060. First, level unit in place, then adjust rear legs to pitch the unit forward 1/4" (6mm) to insure positive drainage of the cylinder.

ELECTRICAL

Connect to proper electrical supply box and disconnect switch as shown on one of the following schematic diagrams - 208 or 240 volts, single or three phase. Connection is made from the rear of the unit, through the conduit to the terminal box located at the front of the unit. See installation specifications on page 5.

OUTSIDE VENTING

Connect 1/2" (13mm) nominal tubing exhaust to outside vent connection located on top of unit, within the control housing. **IMPORTANT: Exhaust line must be vented to the outside to eliminate the exhausted steam and the accompanying noise from entering the room.** Use 1/2" (13mm) copper tubing or suitable alternate. The overall height and length of the line should not rise more than 4 feet (1.2 meters) above the unit and exceed 15 feet (4.5 meters) with a minimum of bends. The line should slope downward after leaving the sterilizer in order to insure condensate drainage.

WATER-COOLED EXHAUST CONDENSER

If outside venting is not possible, an optional water-cooled condenser is available for connection to an open drain. If required order part no. 95-0436 kit.

RECORDING THERMOMETER

If a recording thermometer is provided, refer to installation guide provided with recorder.

TRAY SUPPORTS

Install side tray supports. Tray supports are attached by means of key-hole clearance slots which are slipped over studs located on the sides of the Sterilmatic chamber.

BAFFLE INSTALLATION

To insure maximum drying of packs, a baffle is supplied with your Sterilmatic. Place perforated splash baffle in bottom of the sterilizing chamber. Install small baffle with no perforation at the rear of the upper tray support channel.

NOTE: The perforated baffle is not to be used as a shelf to place media or other items. It is intended to eliminate splashing.

OPERATION CHECK

To check for proper operation of unit:

1. Close drain valve by turning handle clockwise.
WARNING: DO NOT OPEN DRAIN VALVE WHILE UNIT IS OPERATING. PREMATURE OPENING MAY RESULT IN SCALDING OF OPERATOR.
2. Fill chamber with 4 to 6 quarts (3.7 to 5.6 liters) of ordinary tap water. DO NOT USE DISTILLED OR DEIONIZED WATER.

SECTION 1 INSTALLATION INSTRUCTIONS

3. Close chamber door.
4. Set exhaust selector to INSTRUMENTS AND PACKS (*fast exhaust*) or LIQUIDS (*slow exhaust*).
5. Set timer to 15 minutes. Cycle will go to completion automatically.

NOTE: Cycle timer will not start until sterilizing temperature is obtained.

WIRING OF CONDENSING UNIT

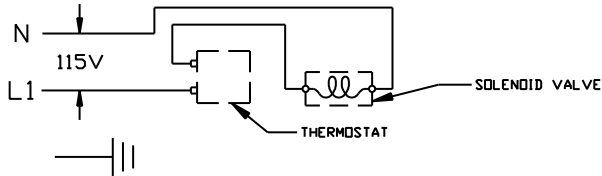

AMPS PER WIRE *STERILIZER					
Phase	3 Phase		1 Phase		208V (197-219) or 240V (220-240)
Volts	208	240	208	240	
Amps	26	30	45	52	

COLD WATER CONDENSER			
ITEM	PART NO.	DESCRIPTION	QTY.
1	95-2119	Steam condensing unit	1
2	95-2219	Thermostat Box Assy.	1
3	95-0086	Exhaust line	1
5	15-7057	Copper tubing 3/8 OD	22.25"
6	10-1775	Rd. Hd. Mach. Screw, 1/4-20	2
7	10-2500	Lockwasher, 1/4	2
8	10-2308	Hex Nut, 1/4-20	2
9	10-1812	Rd. Hd. Mach. Screw, 10-32	2
10	10-2505	Lockwasher, 10	2
11	10-2340	Hex Nut, 10-32	2
12	95-4009	Front Template (7" Lg)	1
13	95-4010	Back Template (11" Lg)	1

SERVICE CONNECTIONS REQUIRED	
A	1/2" IPS Cold Water Connection
B	1" IPS Drain Connection (<i>See Note 3</i>)
C	115V Elec. Connection 7/8 Ø knockout (<i>cond. unit</i>)
D	Electrical Connection

NOTES:

1. Unit must be grounded and all wiring to comply with local codes.
2. Pipe to open drain. Do not make solid connection to sewer.
3. Condensing unit to be installed as to have a back to front pitch.

INSTALLATION INSTRUCTIONS - COLD WATER CONDENSING UNIT (KIT PART NO. 95-0436)

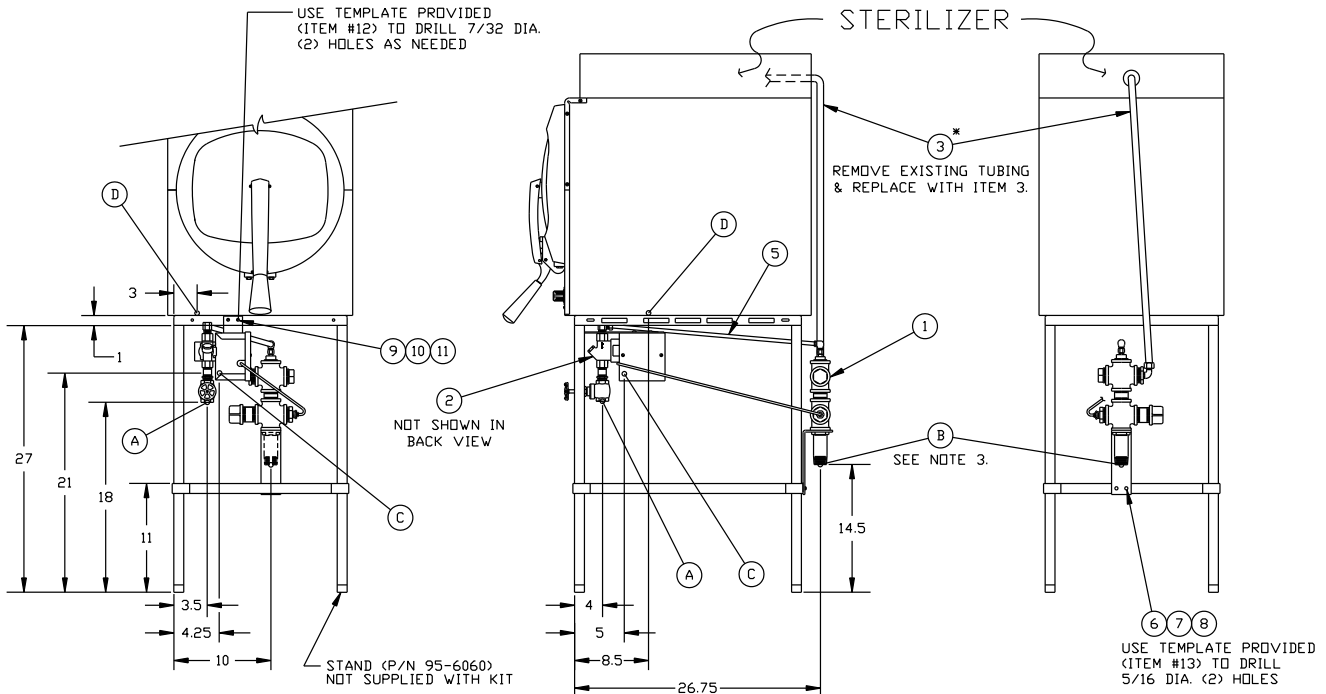

SECTION 1 INSTALLATION INSTRUCTIONS

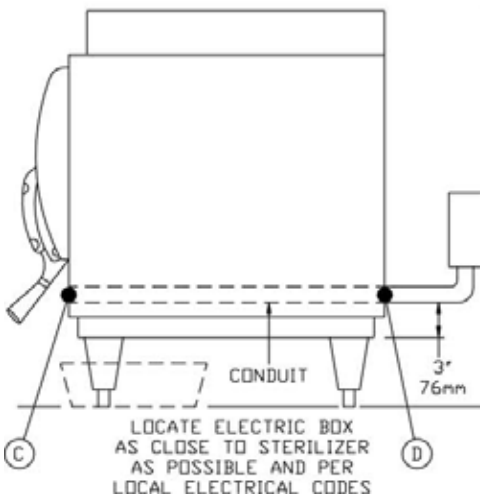
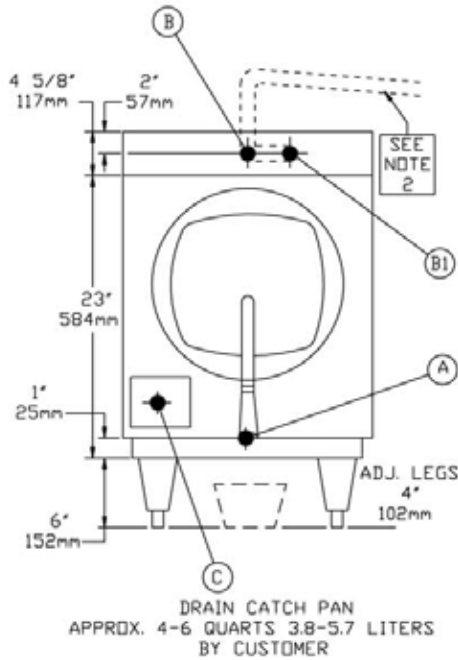
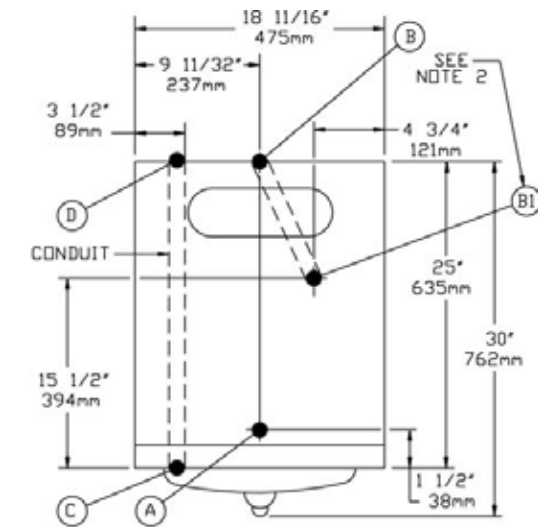

REQUIRED CONNECTIONS:

A	Drain - 1/2" (13mm) FPT of 5/8" (16mm) OD copper (see note 1)
B	Steam Exhaust Connection - 3/8" (10mm) IPS (see note 2)
C	Electrical Connection - (*see table below)
D	Power Supply

*AMP/PHASE						
MODEL	kW	Hz	Single Phase		Three Phase	
			208V	240V	208V	240V
STM-E(L)	9	60	45A	52A	-	-
STM-E(L)	12	60	-	-	26A	30A

UNIT MUST BE GROUNDED.

MAIN SUPPLY VOLTAGE FLUCTUATIONS ARE NOT TO EXCEED ± 10% NOMINAL SUPPLY VOLTAGE

NOTES:

1. An air break must be provided if a unit drain line is run.
2. Vent exhaust to atmosphere. B1 is actual connection, but must exit casing at B.

IMPORTANT: Exhaust line must be vented to the outside to eliminate the exhaust steam and the accompanying noise from entering the room. Use 1/2" (13mm) copper tubing or suitable alternate. The overall height and length of the line should not rise more than 4' (1.2 meters) above the unit and exceed 15' (4.5 meters) with a minimum of bends. The line should slope downward after leaving the sterilizer in order to ensure condensate drainage.

IMPORTANT: Failure to comply with this outline will affect the sterilization process.

When an exhaust condenser is supplied; the following services must be provided: 1/2" (13mm) IPS cold water: 1" (25mm) IPS waste: 115V electrical line.

SECTION 1 INSTALLATION INSTRUCTIONS

INSTRUCTIONS FOR INSTALLING PAN SUPPORTS AND BAFFLES

1. Locate the mounting studs on the inside of the chamber. There are two rack mounting studs on each side (see Fig. 1).
2. Taking one pan support and positioning rack so that the pan stop is facing the rear of the unit and the wires are facing toward the center of the unit. The pan stop is a piece of sheet metal welded to the rack with a 65° bend.
3. Begin to hang the pan support by placing the rear key-way slot onto the rear mounting stud and slide the rack until the slot sits on the mounting stud. When this is done correctly the front mounting stud will be in position to place the front key-way slot. Slide the rack down into its correct position (see Fig 2).

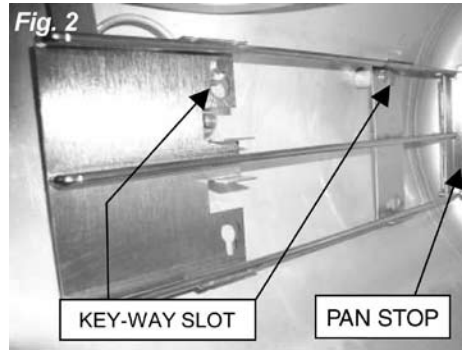
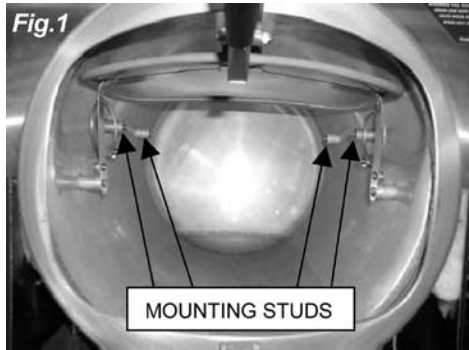

4. After installing one pan support rack correctly, you can install the upper baffle. Position the baffle so that the 45° bend is facing up towards the front of the unit (see Fig. 3). Slide the mounting tab onto the flat bend on the pan stop bracket. The baffle should now stay in place by itself, but in a tilted state (see Fig. 4).
5. Position the second pan support rack into the cavity and slide the other mounting tab onto the rack flat bend while the pan support rack is not on the mounting studs. Hang the pan support by placing the rear key-way slot onto the rear mounting stud and slide the rack until the slot sits on the mounting stud. When this is done correctly the front mounting stud will be in position to place the front key-way slot. Slide the rack down into its correct position.

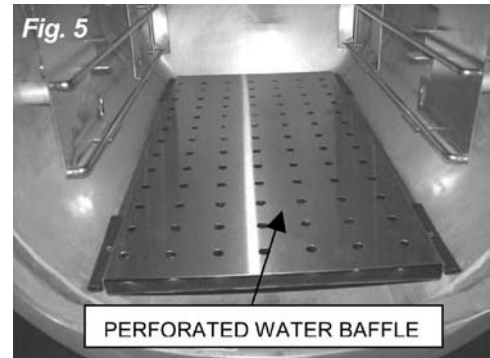
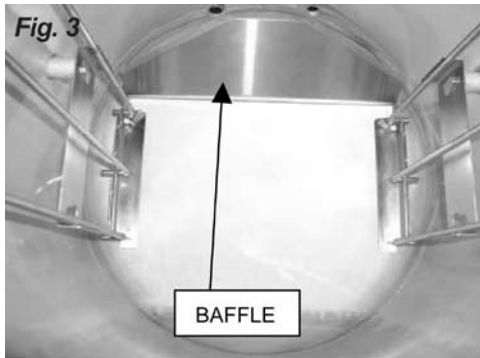

6. Place the Perforated Water Baffle so that it sits on the bottom of the inside of the sterilizer chamber (see Fig. 5).
7. **CAUTION:** Do not cover the holes in the Perforated Water Baffle by using it as a shelf. This will result in a disrupted flow of steam.

THE ELECTRIC SUPPLY CONNECTIONS FOR STM-E AND STM-EL: Connect to proper electrical supply as indicated on nameplate on top of unit. The power supply cord is brought in from the rear of the unit, through the conduit and the connection is made at the terminal box located at the front of the unit.

THE ELECTRIC SUPPLY CONNECTIONS FOR STM-EX AND STM-ELX EXPORT: Connect to proper electrical supply as indicated on nameplate on top of unit. Connection is made from the rear of the unit, through the conduit to the terminal box located at the front of the unit. All control circuits are 220 volts.

In order to accomplish this, a current-carrying grounded neutral must be provided.

Thus, a three phase system must be 4-wires. Most electrical codes require, and we recommend, that a separate switch be located within sight of the sterilizer.

SECTION 1 INSTALLATION INSTRUCTIONS

STM-E & STM-EL Sterilizer: 208V - 240V / 120V, 3 Ø - 4 Wire

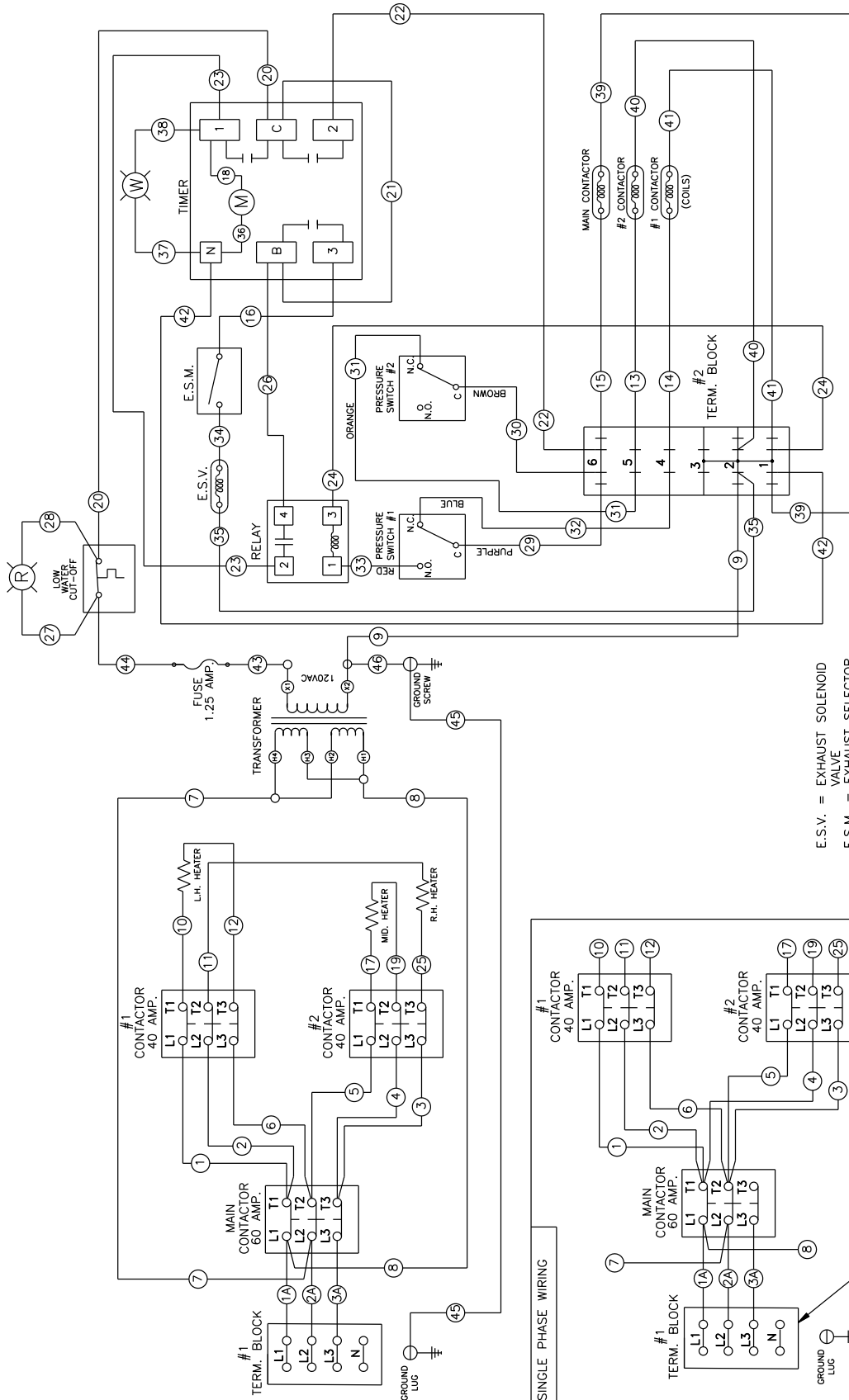

E.S.V. = EXHAUST SOLENOID VALVE
 E.S.M. = EXHAUST SELECTOR MANUAL SWITCH

VOLTS	PHASE	AMPS. PER LINE WIRE			K.W.
		L1	L2	L3	
208	1	45	45	-	9.3
208	3	26	26	26	9.3
220	1	48	48	-	10.4
220	3	28	28	28	10.4
240	1	52	52	-	12.4
240	3	30	30	30	12.4

NOTES:

- SEE WIRE LEAD SCHEDULE C95-3550
- FOR SINGLE (1) PHASE, SUPPLY POWER TO TERMINALS L1 & L2 ONLY

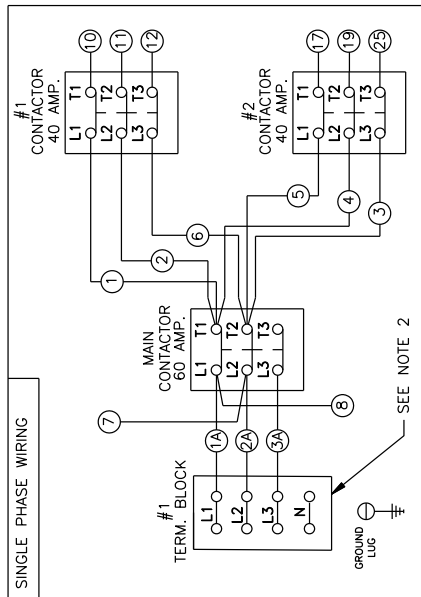

95-2556 REV. J

SECTION 1 INSTALLATION INSTRUCTIONS

EXPORT STM-EX & STM-ELX Sterilizer: 220V / 380V, 3 Ø - 4 Wire, 50 Cycle

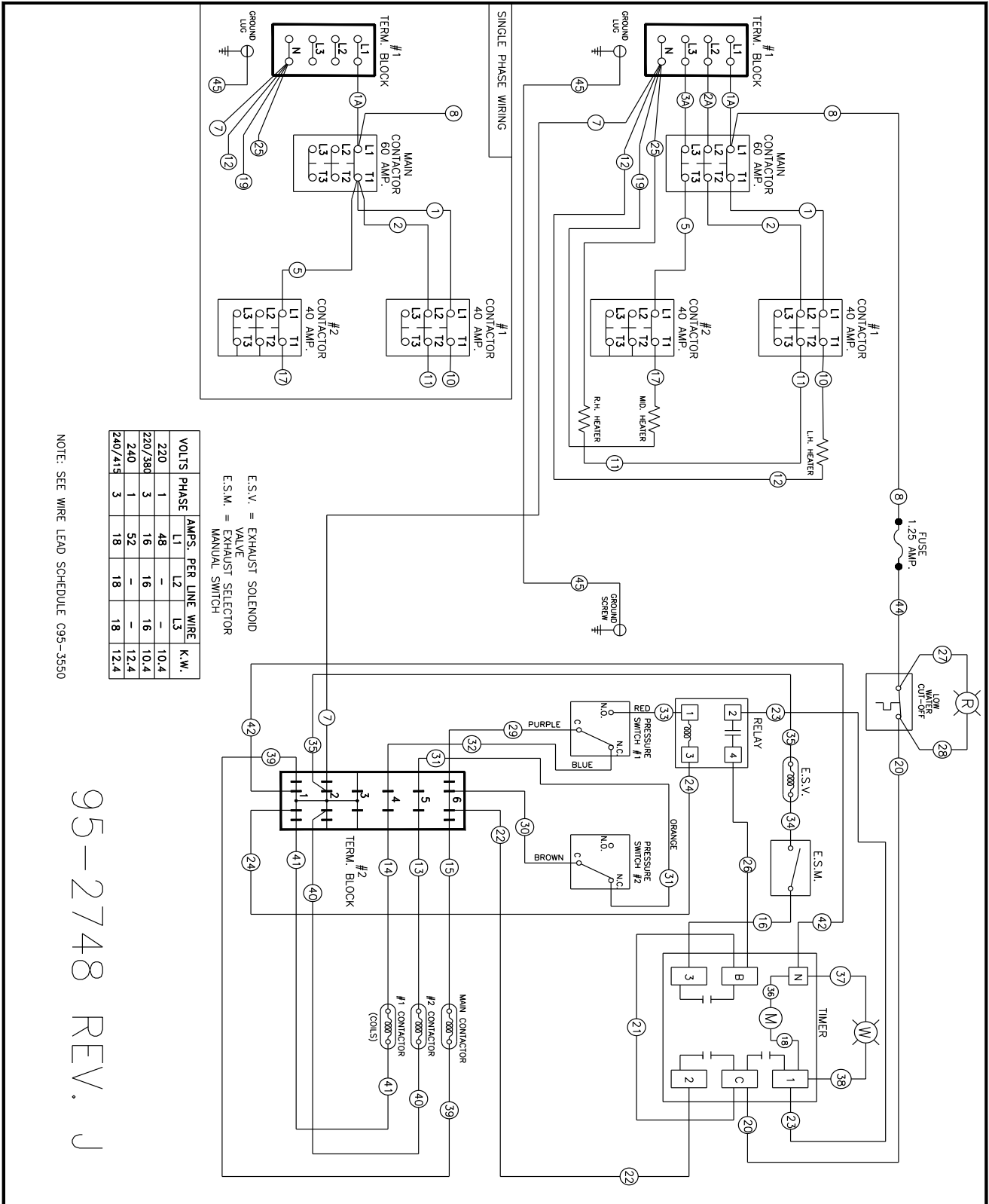

SECTION 1 INSTALLATION INSTRUCTIONS

TYPICAL CIRCUIT CONNECTION FOR STM-E AND STM-EL STERILIZERS

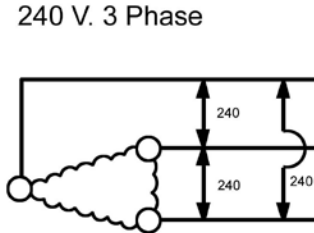
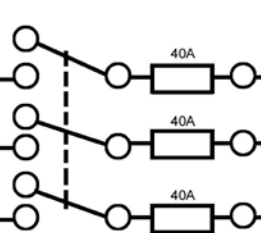
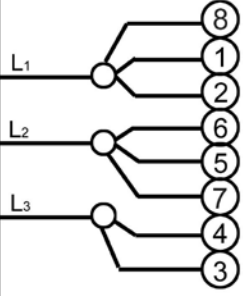
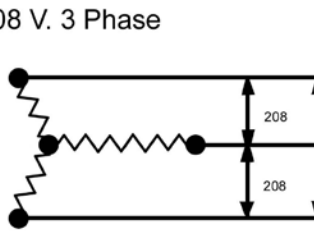
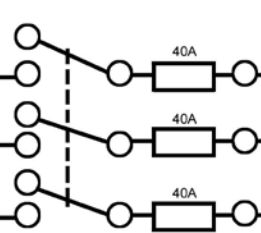
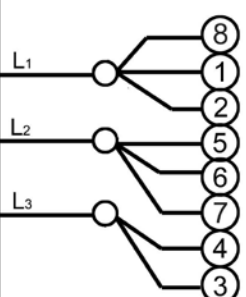
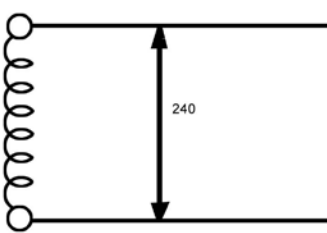
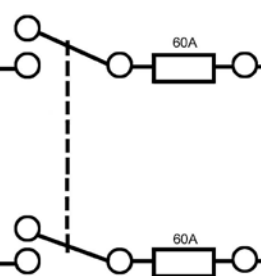
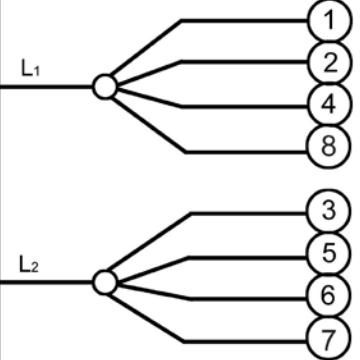
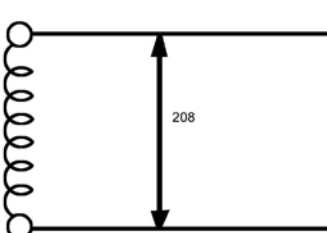
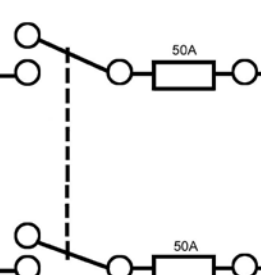
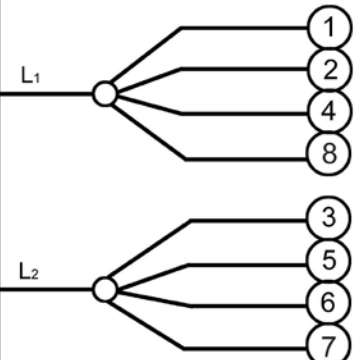
ELECTRICAL SOURCE	FUSE AND DISCONNECTED MEANS	UNIT WIRING
<p>240 V. 3 Phase</p> 		
<p>208 V. 3 Phase</p> 		
<p>240 V. 1 Phase</p> 		
<p>208 V. 1 Phase</p> 		

SECTION 1 INSTALLATION INSTRUCTIONS

TYPICAL CIRCUIT CONNECTION FOR STM-EX AND STM-ELX EXPORT MODELS

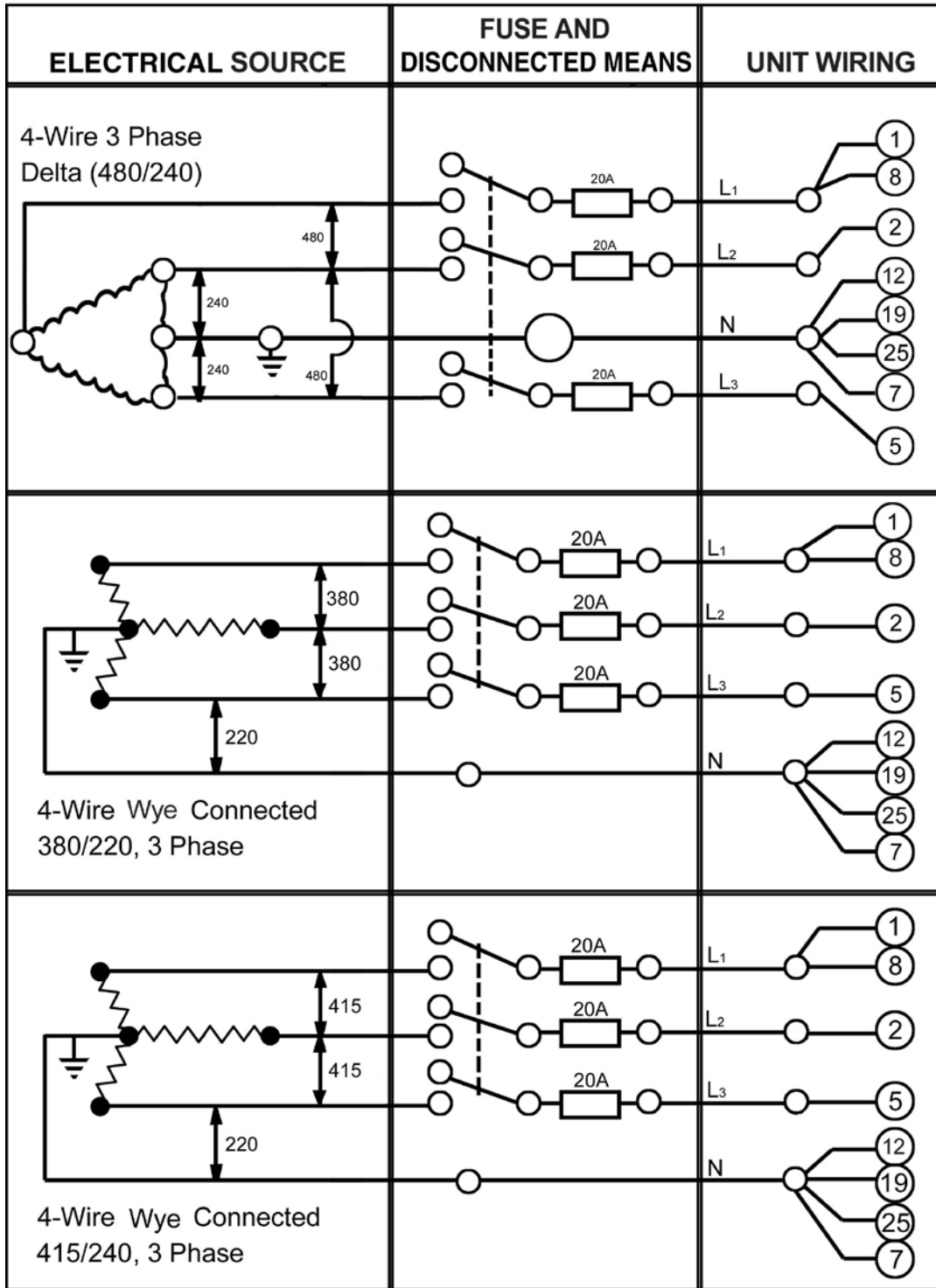

SECTION 1 INSTALLATION INSTRUCTIONS

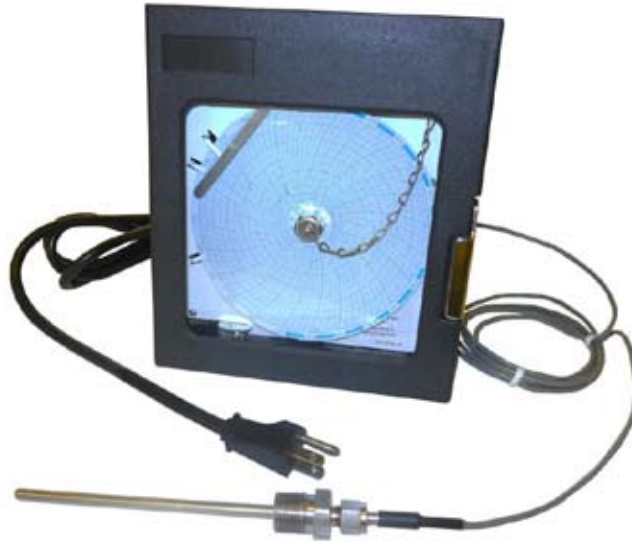

INSTALLATION FOR OPTIONAL RECORDING

THERMOMETER: The optional Recording Thermometer may be surface or panel mounted whichever is preferred.

1. Remove the top cover of the sterilizer. Remove the pipe plug located in the T-fitting that also accommodates the safety relief valve and which is connected directly to the sterilizing chamber. (See *figure to the right*)
2. Insert the RTD temperature sensor of the temperature recorder through the rectangular cutout in the top cover then into the pipe from which the plug was removed.
3. Make sure RTD temperature sensor is protruding down into the sterilizer cavity but not too much so as to interfere with the sheet metal baffle plate. Tighten the compression fitting. Replace top cover onto the sterilizer.
4. For mounting the recorder on a wall, refer to the recorder manual supplied with the recorder.
5. Electrical connections: The 115/120VAC unit comes with a 6' power cord and three prong plug. This can be plugged into any 120V outlet. The 220/230VAC unit comes with a 6' power cord and three prong plug. However, due to the many varieties of plugs and outlets you may need to replace the plug with the appropriate plug.

The Future Design Recording Thermometer is a 24-hour clock and should be run continuously.

Charts should be changed every 24 hours.

TO REMOVE THE CHART:

1. Unscrew and remove the chart 'hub' knob (*attached to the chain*).
2. Grasp the edge of the chart and lift straight off.

TO INSTALL A NEW CHART:

1. Slide edge of the chart under the two raised tabs located under the stylus.
2. Locate the center hole of the chart over the center, threaded rod. Rotate chart to line up the current time of day directly underneath the stylus print head.
3. Screw the chart 'hub' knob back in place, hand tight only.

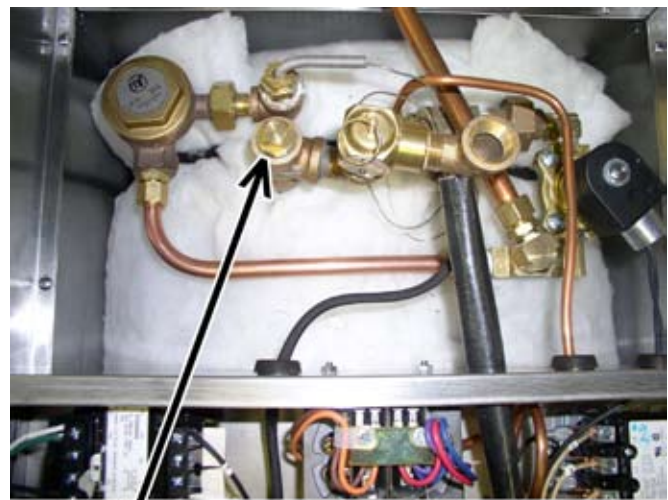

Remove Plug

SECTION 1 INSTALLATION INSTRUCTIONS

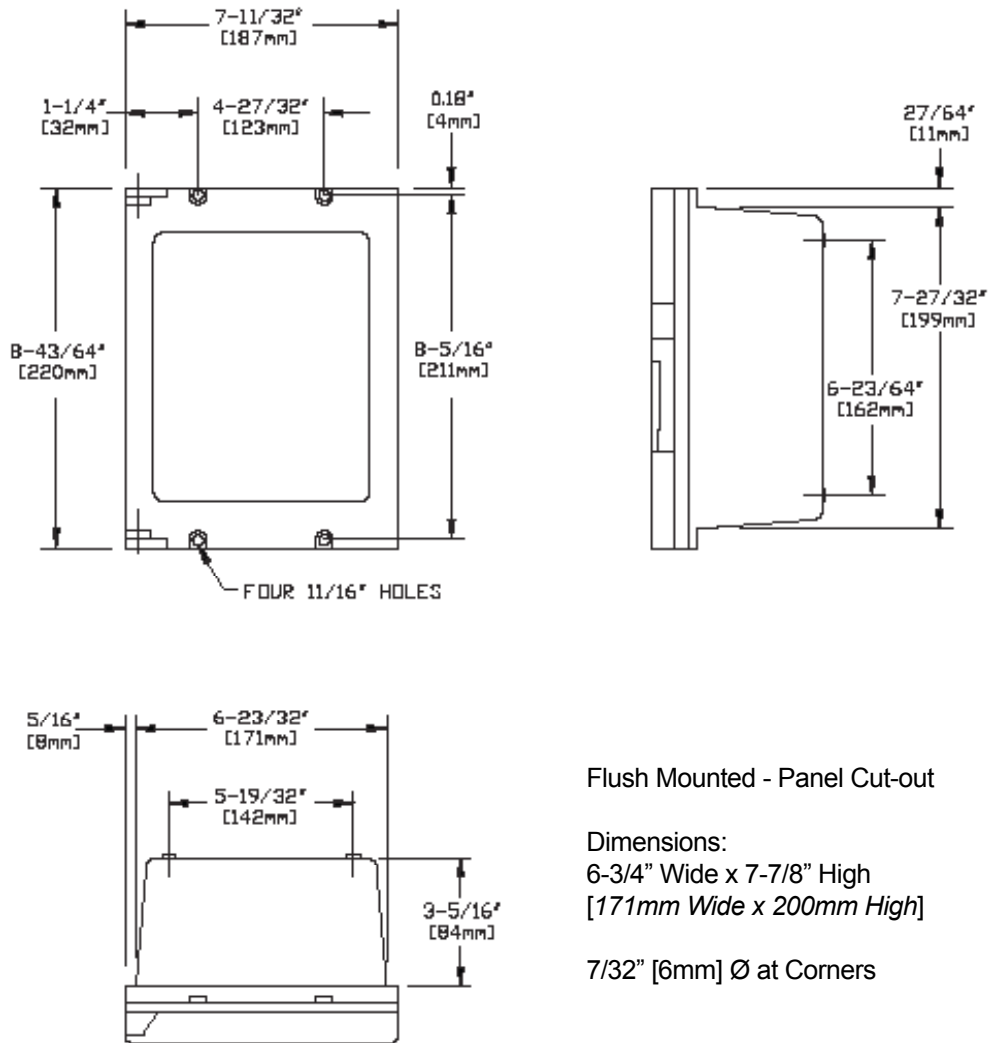

Flush Mounted - Panel Cut-out

Dimensions:
6-3/4" Wide x 7-7/8" High
[171mm Wide x 200mm High]

7/32" [6mm] Ø at Corners

REPLACEMENT CHARTS STERILMATIC CHART RECORDER

Market Forge	Vendor	Description	Qty.
10-7933		Replacement 24 hour thermometer charts, fahrenheit, (°F)	50/box
08-6244		Replacement 24 hour thermometer charts, celsius, (°C)	50/box

SECTION 2 WATER CONDITIONS

Market Forge from time to time is asked the question about using distilled or deionized water for use with our Sterilizer models STM-E and STM-EL. We are always asked why these water choices are not allowed for use with our units and what would be recommended. To address this situation, we have compiled the following as a means of satisfying these questions:

1. We have found that the use of distilled or deionized water will aggressively attack the pure coat of Aluminum Alclad, which protects the bottom surface from oxidizing and then eventually pitting (*reference: Operating and Maintenance Instructions*).
2. In addition pitting can also be caused by several other external environmental factors. Few examples are as follows. These conditions have been highlighted in our documentation.
 - Grains of hardness in the water supply should be as follows (.25 to 2).
 - A pH imbalance in the water supply can greatly af-

fect the life to the aluminum cylinder. The pH range that would be recommended is between 7.0-8.5.

- The lack of a positive electrical ground can cause an electrolytic reaction that will accelerate pitting.
- Another contribution to accelerate pitting is the type of cleaning solutions used or the abrasive scrubbing pads. If a low pH is present with the detergents being used or an abrasive pad, the protective Alclad coating will be removed during the cleaning process.
- Spillage of media being sterilized can also contribute to the accelerated pitting if it is corrosive.
- CHLORINE LEVEL \leq 1 PPM.

IMPORTANT NOTE:

Market Forge will not be responsible for damage resulting from the use of hard or corrosive water, from failure to drain the unit daily, or from inadequate cleaning procedures.

SECTION 3 OPERATING INSTRUCTIONS

OPERATING INSTRUCTIONS:

1. **IMPORTANT:** Make sure the drain valve is closed. Fill bottom of the sterilizer chamber with approximately six quarts of water or just below ledge at bottom of door opening. (*If water supply is known to be hard or corrosive, a source of treated water should be used.*) **DO NOT USE DISTILLED OR DEIONIZED WATER.** (See section 2)
2. **LOAD STERILIZER:** Use proper sterilizer loading procedures when placing materials in sterilizer chamber. All solid containers or instruments must be placed so that water or air will not be trapped in them.
3. **CLOSE DOOR:** Grasp handle, and holding it in vertical position, pull door down until bottom of door rests in the bottom of door opening. Then rotate handle forward, engaging the lower curved portion under the horizontal rod in the casting at the bottom of the door opening. Push handle all the way down and back until door is locked securely in position.
4. **SET EXHAUST SELECTOR:** Located at center of the control housing mounted on top of the unit, to correct position. Unit is now ready to start. All items, other than solutions, may be sterilized with selector at "Instruments". Solutions require a low exhaust. Place selector at "Liquids".
5. **DETERMINE CORRECT STERILIZATION TIMES:** (*Referring to page 11 for minimum re-*

quired times in the sterilization guide and times table.) **NOTE:** *In no case should the timer be set to less than 15 minutes. Sterilization will not be accomplished in less than 15 minutes exposure time.*

6. **TURN TIMER:** Located at upper right front of sterilizer. Select desired length of sterilizing period. This turns power supply on and starts the cycle after pressure-temperature combination has been reached. Amber pilot light indicates that the timer is running.
7. When the sterilizer chamber reaches the selected temperature, the timed exposure cycle will begin. When the exposure cycle is completed, the electric supply will be opened automatically. When the chamber pressure gauge located at the top of the control housing reads "0", the door may be opened. (Release handle and let go to avoid possible contact with remaining steam.) When opening the door, allow a few seconds for steam to escape from chamber before opening completely.
8. To assist in drying racks, release door handle after pressure has been attained at start of cycle. Pressure in chamber will keep door closed. The use of a wire basket will provide better drying for dressings. At end of sterilizing cycle, release door handle and open slightly. Do not lift door to open position. This will allow steam and moisture to escape. Allow door to remain in this position for 15 to 20 minutes before removing load. Small packs can be dried successfully with this procedure. We

SECTION 3 OPERATING INSTRUCTIONS

do not recommend the sterilization of large packs, such as linens. Be sure condensate baffles are in position in the chamber.

9. Remove load and check water level for next operation.

STERILIZATION GUIDE:

- **PACKS (*Linens, gloves, etc.*):** Use wire basket to facilitate drying. Be sure condensate baffles are in place. Place packs on edge and arrange load in chamber, so that only minimal resistant to passage of steam through the load will exist. **NOTE:** *Place gloves in upper two-thirds of chamber.*
- **JARS, CANISTERS (*etc.*):** Place containers on side to allow for displacement of air and complete contact of steam to surfaces. Drying is also facilitated.
- **PETRI DISHES, PIPETTES, DESICCATORS (*etc.*):** Should be inverted.
- **UTENSILS, TREATMENT TRAYS:** Placed on edges to facilitate drying.
- **INSTRUMENT SETS:** Place instruments set in

trays having mesh or perforated bottoms. Place trays flat on shelves.

- **COMBINING FABRICS & HARD GOODS:** Place hard goods on lowest shelves.
- **PLASTIC UTENSILS:** DO NOT stack or nest plastic items.
- **LIQUIDS:** Sterilize medium liquids separately from other supplies or materials. Set exhaust selector to proper position (*liquids*).
- **SMALL ITEMS:** Sterilize small items in baskets, or trays.

NOTE: IF THE EQUIPMENT IS USED IN A MANNER NOT SPECIFIED BY THE MANUFACTURER, THE PROTECTION PROVIDED BY THE EQUIPMENT MAY BE IMPAIRED.

MINIMUM STERILIZATION TIMES

TIME (<i>Minutes</i>)	ARTICLES
15	<ul style="list-style-type: none"> • Glassware, empty, inverted. • Instruments, metal in covered or open tray, padded or unpadded. • Needles, unwrapped. • Pipettes, blood diluting, serological, volumetric, etc • Tubing glass (<i>6mm</i>), (<i>10mm</i>) inverted
20	<ul style="list-style-type: none"> • Flasked solutions 75-250 ml. • Instruments, metal combined with other materials in covered and/or padded tray. • Instruments wrapped in double thickness muslin. • Rubber gloves, catheters, drains, tubing, etc. Unwrapped or wrapped in muslin or paper.
30	<ul style="list-style-type: none"> • Brushes in dispensers, in cans of individually wrapped. • Dressings, wrapped in paper or muslin, small packs only. • Flasked solutions 500-1000 ml. • Syringes, unassembled, individually packaged in muslin or paper. • Needles, luer, individually packaged in glass tubes or paper.
45	<ul style="list-style-type: none"> • Flasked solutions 1500-2000 ml.

SECTION 4 MAINTENANCE

DAILY CLEANING PROCEDURE (AT THE END OF EACH DAY):

1. Remove bottom splash baffle.

NOTE: IMPORTANT! STERILIZING CHAMBER MUST BE CLEANED AND DRAINED DAILY USING THE FOLLOWING PROCEDURE. WASH WETTED PORTION OF THE CYLINDER THOROUGHLY BY ADDING A MILD DETERGENT TO WATER IN CYLINDER.

2. If a soft cloth or brush is used with the detergent and does not completely remove the surface film, a nylon soap pad should be used. After washing thoroughly rinse with clean water. Dry cylinder* and leave door open overnight.

* The Sterilmatic cylinder is constructed of corrosion resistant Alclad aluminum alloy. The protective properties of this material afforded to the interior portion of the cylinder which is exposed to water may be destroyed by allowing a film to form. Such a film can be caused by salts or other contaminants in the water. Corrosion may also occur if water is not drained daily.

SECTION 5 FIELD SERVICE INSTRUCTIONS & ASSEMBLY



STERILMATIC OPEN STAND:

Market Forge Sterilmatic Stand can be supplemented with an Optional Stand for utility use where maximum compactness is desired.

The sturdy, stainless steel unit is equipped with adjustable leg extensions which allow the unit to be installed and leveled over existing contours in the floor.

The open design lends itself to maximum sanitary conditions because of the ease with which periodic cleaning can be done.

Though simple in design and appearance, the steril-matic stand is the ideal arrangement for mounting in that it allows secondary air to circulate.

STERILMATIC OPEN STAND WITH CONDENSER:

Market Forge can provide the open stand with an optional steam condenser system for use where steam exhaustion into the room is undesirable.

The condenser is automatically controlled by the thermostat. The normal factory thermostat setting is 130°F (54°C). The open under-shelf of the stand gives added utility providing a handy tabouret for utensils and access for drainage of water from the sterilizing chamber.

PARTS LIST FOR CONDENSER WITH OPTIONAL STAND:

PART NO.	50 Hz	DESCRIPTION
10-4653	10-4653	Thermostat
10-4035	10-7074	3/8" Solenoid
10-5731	10-5731	1/2" Water Stop Valve
95-2106	95-2106	Water Injection Assy.
95-1680	95-1680	Shelf

STERILMATIC DOOR ASSEMBLY:

The Door of the Sterilmatic has been engineered to establish a positive method of sealing the steam pressure within the sterilizing cylinder. As steam pressure builds up within the cylinder, the door seal will tend to become more positive.

However, the door should be adjusted to make a good initial seal between the door gasket and the door opening without the added assistance of internal cylinder steam pressure with the simple action of securing the door handle down in a locked position, the door gasket should be sufficiently compressed against the door opening, all the way around to prevent any steam leakage from occurring.

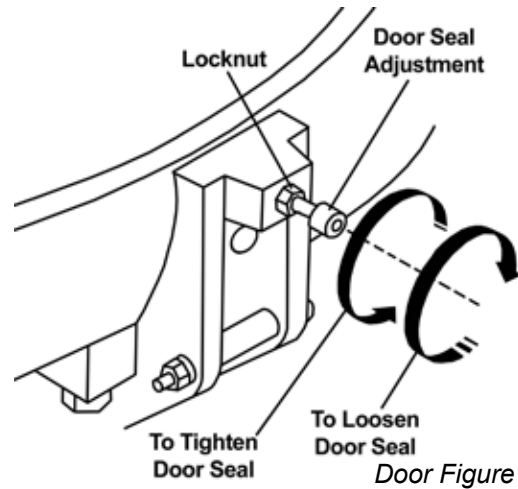

Door Figure 1.

DOOR ADJUSTMENT:

The Door Adjustment is Located in the Fulcrum Casting at the base of the door opening. This adjustment employs the use of a screw and locknut in order to adjust the Sterilmatic Door to a tighter closed position (*to prevent steam from leaking by the door gasket as pressure builds up*), it is necessary to loosen the locknut and back off the screw at least one-quarter of a turn and re-tighten the locknut (*see Door figure 1 shown above & Door Figure 2 shown below*).

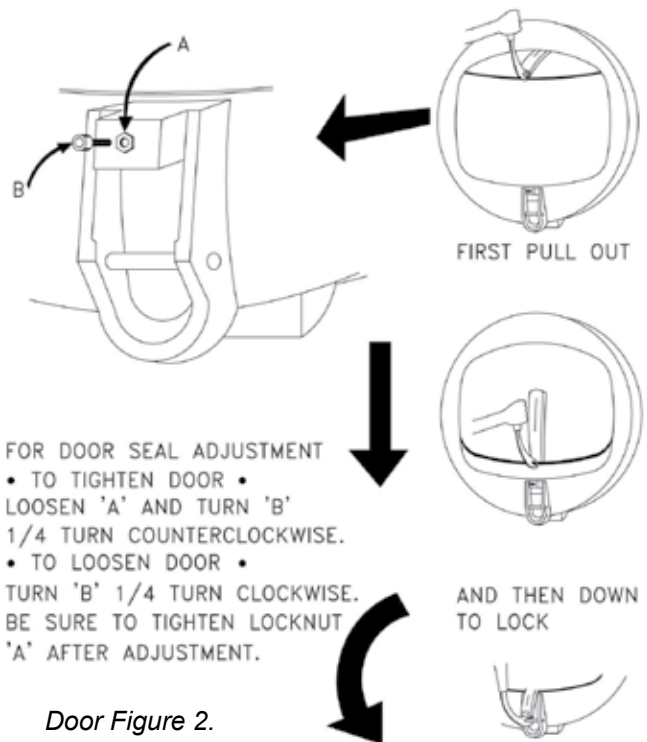

Door Figure 2.

SECTION 5 FIELD SERVICE INSTRUCTIONS & ASSEMBLY

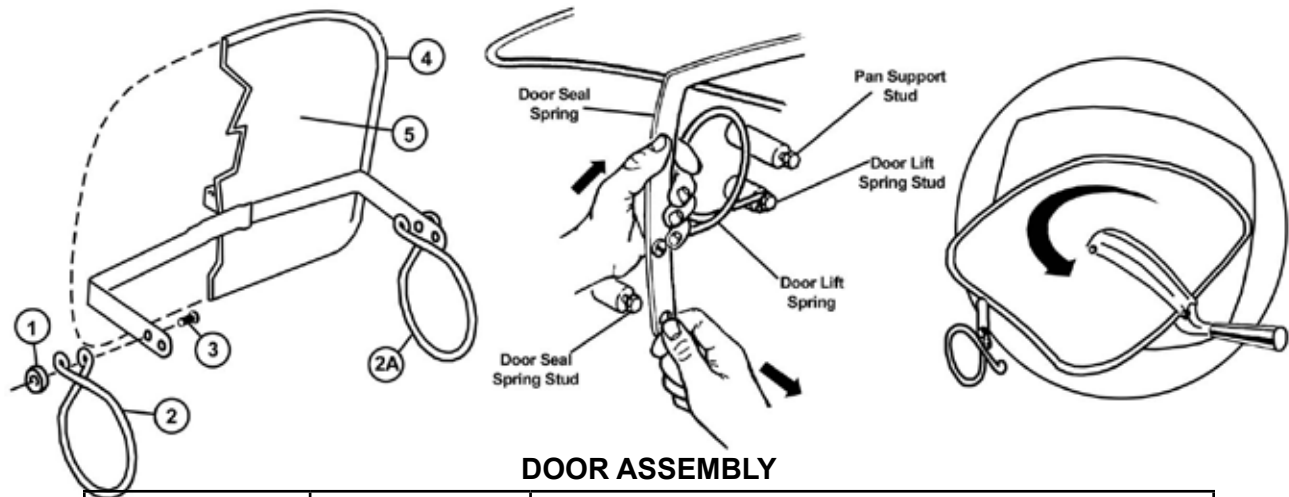

DOOR ASSEMBLY

ITEM	PART NO.	DESCRIPTION
1	10-6765	Pivot Spring Bearing
2	91-2718	Right and Left Door Spring (<i>sold as a pair</i>)
3	10-1776	10-32 Machine Screw 1/2" Long
4	10-2666	Door Gasket
5	95-3204	Door & Door Spring Assembly
-	95-0124	Items 1 through 5

THE DOOR GASKET:

Keep the gasket clean. With normal closing and locking of the door assembly, a steam-tight seal should be made between the door gasket and the door opening. This seal cannot be maintained if particles of foreign matter are allowed to accumulate upon either of the contacting surfaces.

If there is leakage by the door gasket before a steam build-up within the steam chamber and leakage does not stop when the sterilizer reaches sterilizing temperature and pressure than regard the door assembly as improperly adjusted. A re-adjustment must then be made of the seal adjustment door screw.

To change the door gasket, remove the entire door assembly as a unit. Discard the old gasket, replace it with a new one (no cement is required), and reinstall the door assembly. Make an operational check for leakage and adjust the door, if necessary.

DOOR LIFT SPRING:

Market Forge supplies door lift springs in sets only. This policy has been found to be in the best interest of the customer. Through continuous use, some of the original qualities of the springs are lost and it becomes advantageous to make replacements to both the left and right door lift springs in the event that one becomes damaged or broken.

Replacement door lift springs are marked with tabs at the factory prior to shipment to identify a right from a left spring. These springs must be installed with the right door lift spring on the right of the door and the left door lift spring on the left of the door as viewed from the front of the sterilizer.

TO REMOVE THE DOOR ASSEMBLY:

The Door Assembly can be removed from the inner sterilizing chamber as a unit without the use of any special tools or equipment. However, a systematic approach to this is warranted as the clearances through the portal are close, and much confusion can result if not removed in the sequence described below:

1. First, lift off and remove the two pan supports to expose the door linkage on either side of the inner sterilizing chamber .
2. Raise the door to a fully opened position, and disengage the door spring from each of the door spring studs. Accomplish this by counteracting the force of the door lift spring with one hand while working the end of the door spring off the spring stud with the free hand. Do this on both sides of the door assembly.
3. When the end of the door springs have been completely freed from their respective door spring studs, the door springs on either side of the door assembly can easily be slipped off their studs.
4. Rotate the entire door assembly out through the door opening, passing the door handle through the opening first, and then one end of the door spring as shown in the illustration. The remainder of the door assembly will then pass through the door opening quite easily.
5. To replace the door assembly, reverse the step-by-step procedure described above.

SECTION 5 FIELD SERVICE INSTRUCTIONS & ASSEMBLY

THE FULCRUM & DRAIN ASSEMBLY:

The fulcrum and drain assembly is located at the lower front of the sterilizing chamber and furnishes a sturdy anchorage for the door locking system of the door handle. Also provided in this assembly is a means for adjustment of the door seal. The drain port and drain valve provide a means of discharging accumulations of water from within the sterilizing chamber.

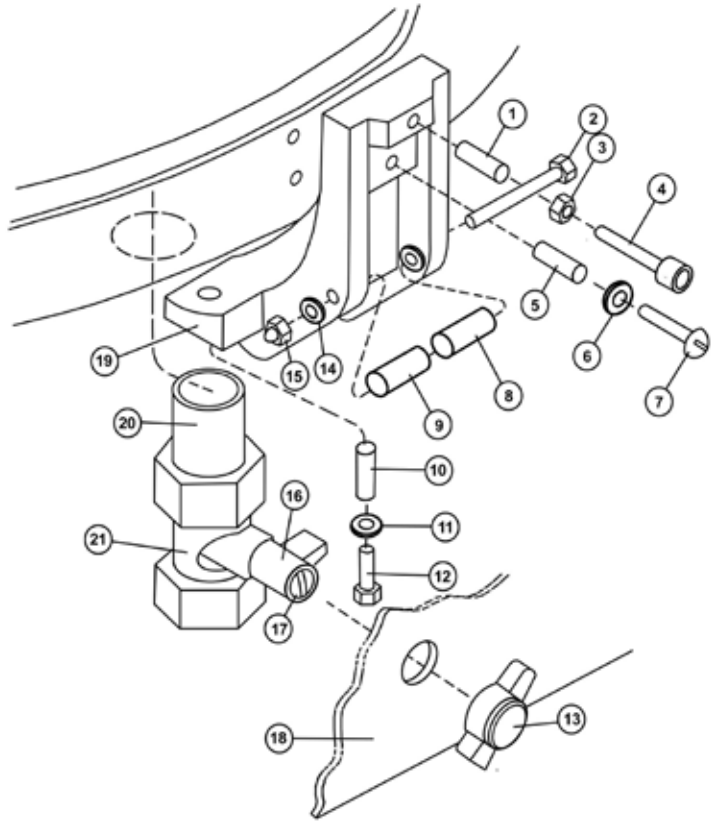

ROLLER ASSEMBLY (Items 8 & 9):

The Roller Assembly must be kept free-rolling at all times. Should this assembly be allowed to become frozen due to lack of lubrication, undue strain will be put on the door handle and the fulcrum casting while the door is being locked. Use only a dry lubricant such as graphite; as oil or grease will tend to attract dirt to this area.

FULCRUM & DRAIN ASSEMBLY

ITEM	PART NO.	DESCRIPTION
1	10-3116	1/4" - 20 X 5/8 helicoil
2	10-1999	10-32 Machine screw, 1 5/8" long
3	10-2358	1/4" - 20 fulcrum nut
4	10-2087	1/4" - 20 allen set screw
5	10-3111	1/4" - 20x 3/8 helicoil
6	10-2513	1/4" Shakeproof washer
7	10-1763	1/4" - 20 Machine screw 3/4" long
8	95-0120	Bearing spacer
9	95-0198	Bronze Bearing
10	10-3111	1/4" - 20 x 3/8 helicoil
11	10-2513	1/4" Shakeproof washer
12	10-1790	1/4" - 20 Cap screw 7/8" long
13	10-4485	Drain valve knob
14	10-2514	#10 Shakeproof lockwasher
15	10-2318	10-32 acorn nut
16	95-2643	Adapter - steinball valve
17	10-1950	6-32 Round head screw 1 5/8" long
18	95-2616	Front outer case lower
19	95-0116	Fulcrum and drain casting
20	10-1049	Nipple 1/2" IPS 2 1/4" long stainless steel
21	10-1041	Ball valve stein
-	95-0115	Fulcrum and drain assembly, Items 1 through 12, 14, 15, and 19

SECTION 5 FIELD SERVICE INSTRUCTIONS & ASSEMBLY

DOMESTIC

THE PRESSURE ACTUATED TEMPERATURE CONTROL, STM-E AND STM-EL :

The pressure actuated temperature control, located behind the control panel assembly, governs the manufacture of steam by controlling the input of electric current to the heating elements.

HOW IT WORKS: When the Timer is set, rear and front contactors will become energized allowing input of current to the temperature control, thus closing the contacts completing the current to the heating elements. Steam will then be generated within the sterilizing chamber.

The steam pressure within the sterilizing chamber is transmitted by means of a tube to the bellows of the temperature control; as the steam pressure increases, its compression action on the bellows is set to cause the Switch #1 on the control to cut out on rising pressure at 13.5 PSI and to cut in on falling pressure at 13 PSI (*controlling the two outer banks of heating elements*). Switch #2 is set to cut out on rising pressure at 15.5 PSI and cut in on falling pressure at approximately 15 PSI (*controlling center heater element only*).

Thus, a balancing effect of steam pressure build-up and heater element current is constantly maintained during the sterilizing cycle. When the Timer signifies the end of the cycle, the electric current to the contactors will automatically be broken; the temperature control contacts will be broken; and steam generation will stop.

ADJUSTING THE RANGE OF OPERATION, STM-E:

NOTE: These instructions should be performed by qualified service personnel only.

The operational range of the temperature control is factory set as follows: Outer bank of elements OFF at 13.0-13.5 PSI; Center bank of elements OFF at 15.5- 15.0 PSI; minor compensating adjustments can be made by turning the adjusting screws counter-clockwise to increase pressure and clockwise to decrease pressure. Both screws should be turned the same amount when making an adjustment.

NOTE: When resetting this control for elevations above sea level a correction of 6/10 lb. per thousand feet is necessary.

1. Before making adjustments, shut all electrical current to the sterilizer OFF to eliminate shock hazard.
2. Remove the Flue Cover.
3. Make sure that all exposed wires are not in a hazardous position, and then turn on electrical power.
4. Run unit through cycle, observing pressure and

temperature gauges, turn adjusting screws as required.

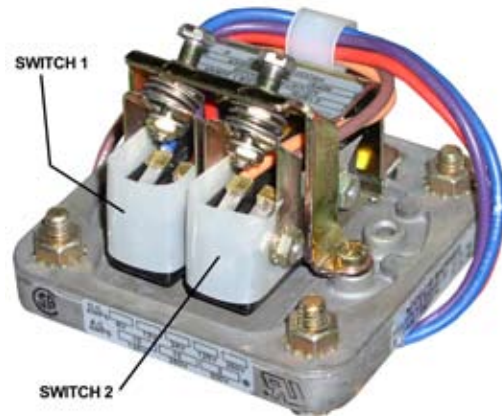

EXPORT

THE PRESSURE ACTUATED TEMPERATURE CONTROL, STM-EX AND STM-ELX:

The pressure actuated temperature control, located behind the control panel assembly, governs the manufacture of steam by controlling the input of electric current to the heating elements.

HOW IT WORKS: When the timer is set, rear and front contactors will become energized allowing input of current to the temperature control, thus closing the contacts completing the current to the heating elements. Steam will then be generated within the sterilizing chamber.

The steam pressure within the sterilizing chamber is transmitted by means of a tube to the bellows of the temperature control; as the steam pressure increases, its compression action on the bellows causes the contacts to make or break according to the condition of the pressure at that time (*rising or falling*).

Switch #1 on the control is set to cut out on rising pressure at 0.95 kg/cm^2 and to cut in on falling pressure at 0.91 kg/cm^2 (*controlling the two outer banks of heating elements*). Switch #2 is set to cut out on rising pressure at 1.09 kg/cm^2 and cut in on falling pressure at approximately 1.05 kg/cm^2 (*controlling center heater element only*).

Thus, a balancing effect of steam pressure build-up and heater element current is constantly maintained during the sterilizing cycle. When the Timer signifies the end of the cycle, the electric current to the contactors will automatically be broken.

CHECKING THE 110°C. SETTING, STM-ELX:

The Unit should be completely evacuated then temperature selector dial turned to 110°C Centigrade. Observe the current until it takes a sharp drop to approximately one-third of the full load; at this instant, there should be a corresponding chamber pressure of 0.14 kg/cm^2 .

SECTION 5 FIELD SERVICE INSTRUCTIONS & ASSEMBLY

Observing the current further will show another sharp drop to approximately 1 Amp; at this instant, there should be corresponding chamber pressure of 0.43 kg/cm² and a temperature reading of 110°C Centigrade, on the temperature gauge.

ADJUSTING THE RANGE OF OPERATION, STM-ELX:

The range of operation of Model STM-ELX is adjusted by simply turning the adjusting knob on the outside of the Control Panel. A counter-clockwise turn decreases the pressure while a clockwise turn increases the pressure. Observe pressure and temperature gauges and adjust knob as required.

NOTE: When resetting this control for elevations above sea level, a correction of 0.13 kg/cm² per kilometer elevation is necessary.

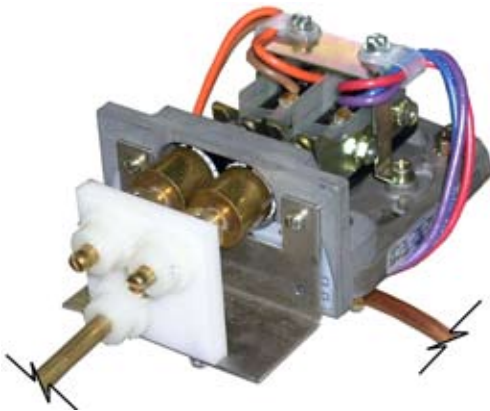

DOMESTIC

CHECKING THE 230° SETTING, STM-EL:

The Unit should be completely evacuated then temperature selector dial should be turned on 230° Fahrenheit. Observe the current until it takes a sharp drop to approximately one-third of the full load; at this instant, there should be a corresponding chamber pressure of 2 PSI

Observing the current further will show another sharp drop to approximately 2 Amps; at this instant, there should be a corresponding chamber pressure of 6.1 PSI and a temperature reading of 228° to 232° Fahrenheit, on the temperature gauge.

ADJUSTING THE RANGE OF OPERATION, STM-EL:

The range of operation of Model STM-EL is adjusted by simply turning the adjusting knob on the outside of the Control Panel. A counter-clockwise turn decreases the pressure while a clockwise turn increases the pressure. Observe pressure and temperature gauges and adjust knob as required.

NOTE: When resetting this control for elevations above

sea level, a correction of 6/10 lbs. per thousand feet is necessary.

CAST-IN HEATING ELEMENTS:

Located under the sterilizing cylinder is a bank of (3) U-shaped heating elements. These elements are welded in place in a protective aluminum shield. The elements cannot be removed, and in the unlikely event that one or all fail, the complete cylinder must be replaced.

THE LOW WATER CUT-OFF (MANUAL RESET):

Fastened to a special mounting brace behind the front panel, the Low Water Cut-Off acts to shut off the complete unit, should the water run dry. The Low Water Cut Off is factory set, to shut the unit off when the cylinder temperature rises between 380° and 440° Fahrenheit.

When the Sterilmatic is turned on without water or the water has been evaporated away, the temperature of the aluminum sterilizing cylinder will rise and by heat induction effect the Low Water Cut-Off. Its inner electrical contacts will be forced open from heat expansion, thus cutting off the flow of electric current to the heating elements. With the replacement of water into the cylinder the cylinder temperature will drop and the contacts of the Low Water Cut-Off can be again closed. The unit will only restart after the manual button has been reset.

THE ELECTRIC CONTACTORS:

The Electric Contactors are located on the top of the unit, underneath the top flue cover. These important components receive an electrical impulse when the Timer is turned on. When the unit reaches a pre-set pressure of 13-13.5 PSI the #1 switch will cut out causing the front contactor to become de-energized. This, in turn, will disconnect the left and right bank of heaters and the timer motor will start.

THE TIMER:

The Sterilmatic is put into operation with the manual setting of the timer. With the setting of the timer, an electrical current is directed to the pressure control. The current energizes the pressure control, which activates the contactor coils to cause a current flow to the heating elements. When the cylinder pressure reaches 13 to 13.5 PSI, the timer motor and pilot light are energized. At the end of the cycle the timer will cut off the flow of electricity to all the components except the exhaust, the exhaust solenoid and the timer motor. They will revert back to their original deactivated state. The timer motor and pilot light will continue to be energized after the timed sterilizer cycle has been completed and for two additional minutes. Only after this will the timer and white pilot light be de-energized. If the timer fails to operate the Sterilmatic, replace it. The timer is replaceable only as a complete unit as factory repairs to it would not be practical in the economical interests of the customer.

SECTION 5 FIELD SERVICE INSTRUCTIONS & ASSEMBLY

THE STEAM PRESSURE GAUGE:

The Steam Pressure Gauge registers the pressure of steam, which is within the sterilmatic sterilizing chamber. To replace this unit, it is necessary to disconnect the copper tubing and to remove the two nuts holding the gauge framework in place.

THE SAFETY VALVE:

The Safety Valve is factory set to automatically open and exhaust excess steam from within the sterilizing cylinder, thereby assuring that operating pressures remain within safe limits. The lever action of the safety valve must be free to operate unrestricted at all times. If the Safety Valve should leak continually with a pressure build-up or should it cause an interruption on a sterilizing cycle prematurely (below 124° Centigrade on the temperature gauge), it must be replaced. However, the temperature gauge should first be checked for accuracy.

THE FLUE:

The Flue serves as a protective shield for the steam trap safety valve, exhaust valve, and electrical components as well as a mounting base for the control panel. The pressure gauge, dial thermometer, exhaust valve switch and timer, protrude through the control panel. The Flue cover may be removed to allow more room for servicing the control components. The control panel face may then be removed by unscrewing the sheet metal screws, which mount it

THE EXHAUST SOLENOID VALVE:

The exhaust solenoid is normally closed and only opens at the end of the cycle when it is energized.

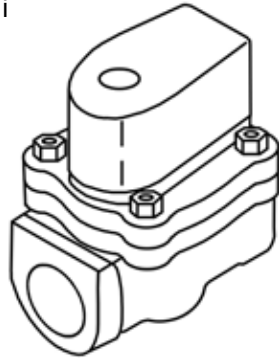

THE STEAM TRAP:

The Steam Trap has the very important automatic, dual function of exhausting all air from the sterilizing compartment, and of making a suitable seal to allow a pressure build-up of live steam during a cycle of sterilization. Also, a slot is milled at an angle through the seat to allow a constant bleed-off of a slight amount of steam during the cycle to completely eliminate any air pockets in the cylinder. Failure of the trap to operate properly will result in an uneven distribution of live steam within the compartment.

HOW IT WORKS:

With the introduction of steam into the sterilizing compartment, cold air will escape. When sufficient generated steam displaces the cold air, it will then start to exhaust through the steam trap to heat the thermostatic element. The expansion of the thermostatic element will make a seal against the seat to enclose the live steam within the sterilizing compartment and a steam pressure build-up will occur.

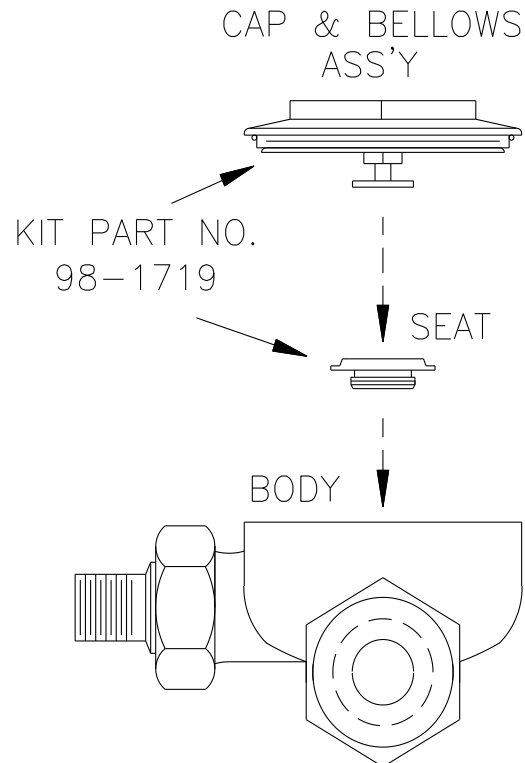

TO REPLACE A THERMOSTATIC ELEMENT:

1. Remove the cap of the steam trap (*turn it counter-clockwise*).
2. Unscrew the diaphragm and seat and discard.
3. Wipe all dirt and scale from the inside of the steam trap.
4. Place a new diaphragm and seat securely into the steam trap and replace the cap (*New Style - Part No. 98-1719*).

SECTION 6 ILLUSTRATED PARTS

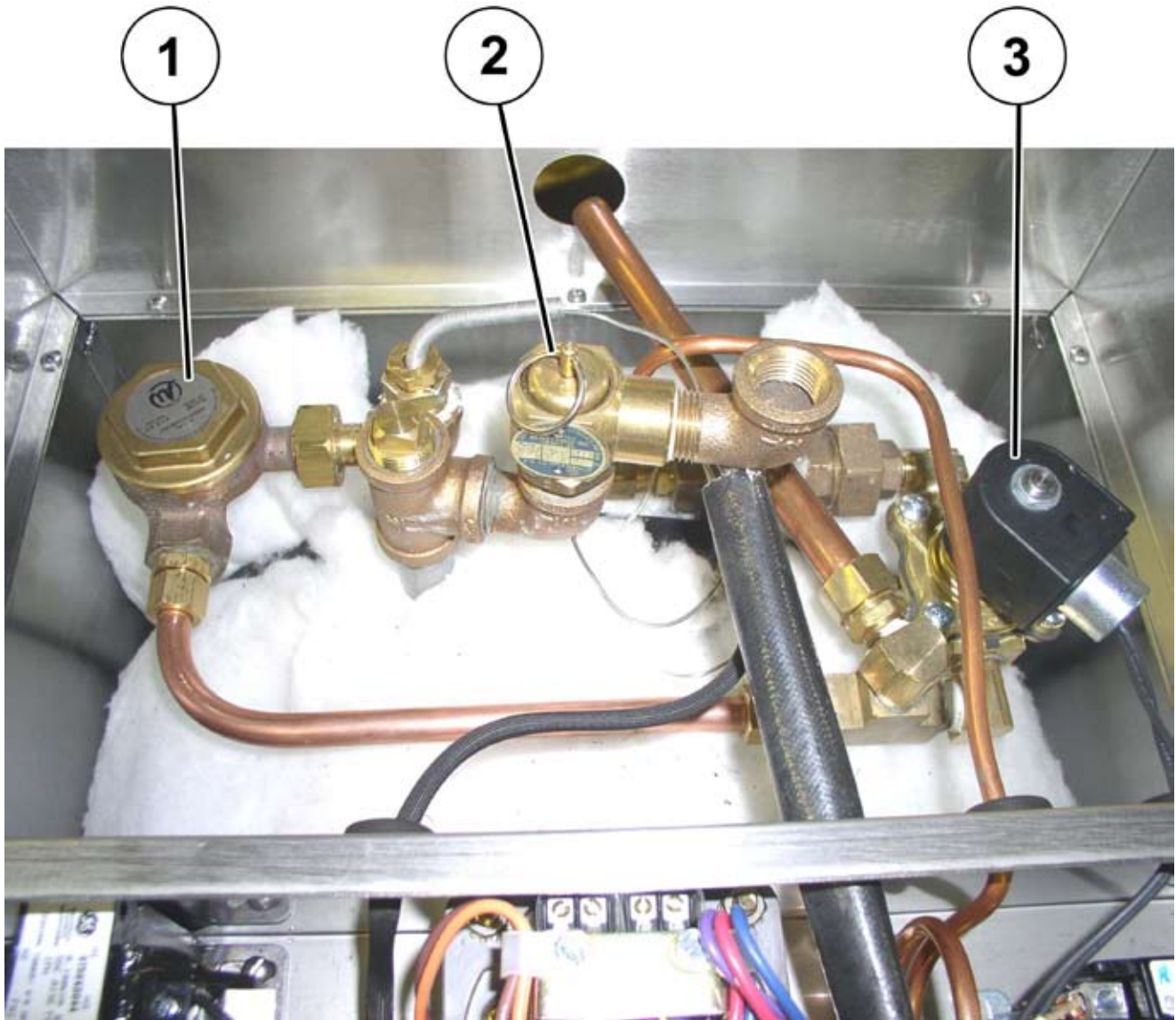

ITEM	STM-E(L)		STM-E(L)X (EXPORT)		DESCRIPTION
	QTY.	PART NO.	QTY.	PART NO.	
1	1	10-4958	1	10-4958	Steam Trap
2	1	10-7942	1	10-7942	Safety Valve, 17 lbs.
3	1	10-1058	-	N/A	Exhaust Valve, 120V
3	-	N/A	1	10-0938	Exhaust Valve, 240V

SECTION 6 ILLUSTRATED PARTS

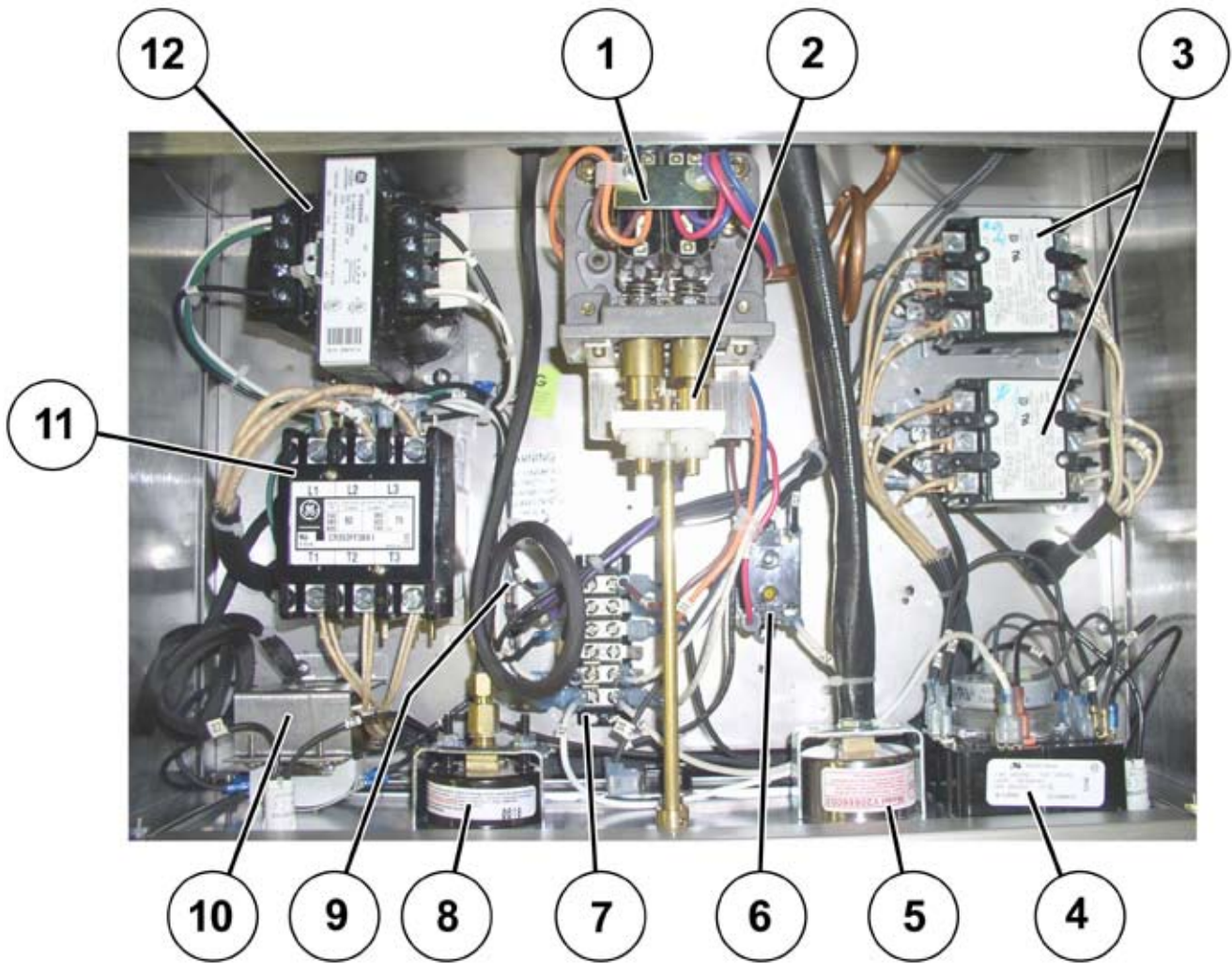

ITEM	STM-EL		STM-ELX (EXPORT)		DESCRIPTION
	QTY.	PART NO.	QTY.	PART NO.	
1	1	95-3434	1	95-3434	Barksdale Pressure Switch
2	1	95-2907	1	95-2907	Pressure Switch Gear Assy.
3	2	10-5944	-	N/A	Contactor, 120V Coil
3	-	N/A	2	10-5943	Contactor, 240V Coil
4	1	10-6290	-	N/A	Timer, 120V
4	-	N/A	1	10-6873	Timer, 240V
5	1	10-9268	1	10-9268	Temperature Gauge
6	1	10-6515	-	N/A	Relay, 120V
6	-	N/A	1	10-6874	Relay, 208/240V
7	1	10-6005	1	10-6005	Terminal Block
8	1	10-9267	1	10-9267	Pressure Gauge
9	1	08-6469	1	08-6469	Fuse Holder
10	1	10-5990	1	10-5990	Low Water Cut-off
11	1	09-6483	-	N/A	Contactor, 75 Amps, 120V
11	-	N/A	1	09-6484	Contactor, 75 Amps, 240V
12	1	10-7355	1	10-7355	Transformer, 100 KVA, 60Hz

SECTION 6 ILLUSTRATED PARTS

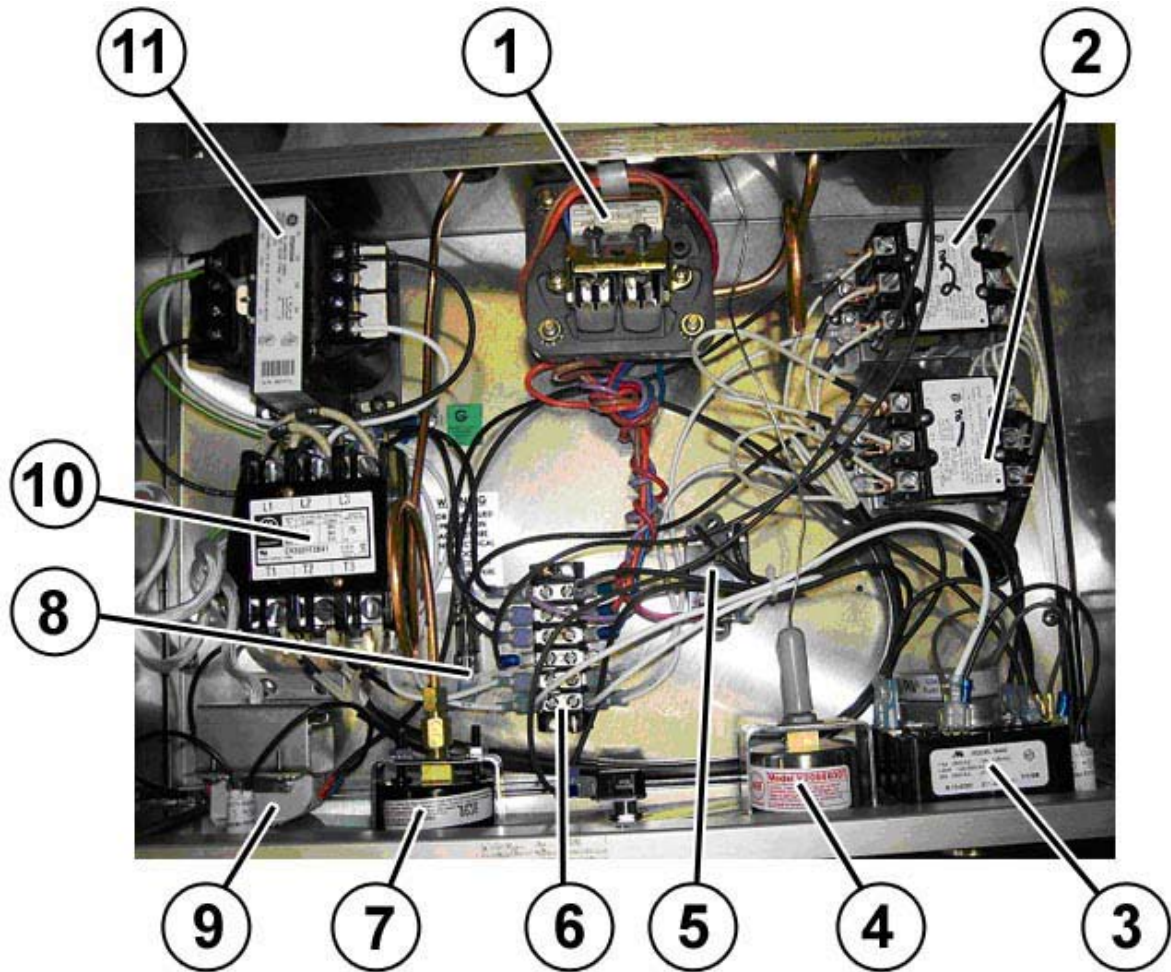

ITEM	STM-E		STM-EX (EXPORT)		DESCRIPTION
	QTY.	PART NO.	QTY.	PART NO.	
1	1	95-3442	1	95-3442	Barksdale Pressure Switch
2	2	10-5944	-	N/A	Contactor 120V Coil
3	-	N/A	2	10-5943	Contactor 240V Coil
3	1	10-6290	-	N/A	Timer 120V
4	-	N/A	1	10-6873	Timer 240V
4	1	10-9268	1	10-9268	Temperature Gauge
5	1	10-6515	-	N/A	Relay, 120V
6	-	N/A	1	10-6874	Relay, 208/240V
6	1	10-6005	1	10-6005	Terminal Block
7	1	10-9267	1	10-9267	Pressure Gauge
8	1	08-6469	1	08-6469	Fuse Holder
9	1	10-5990	1	10-5990	Low Water Cutt-Off
10	1	09-6483	-	N/A	Contactor, 75 Amps, 120V
10	-	N/A	1	09-6484	Contactor, 75 Amps, 240V
11	1	10-7355	1	10-7355	Transformer, 100KVA, 60HZ

SECTION 6 ILLUSTRATED PARTS

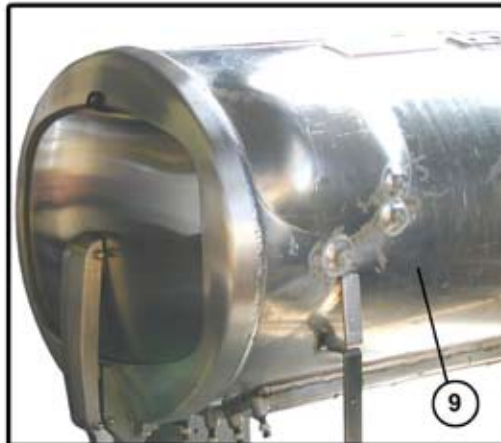
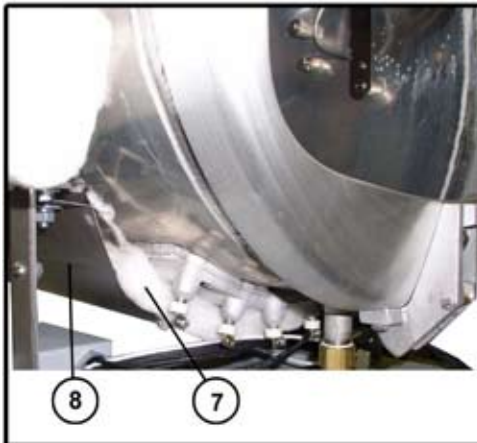
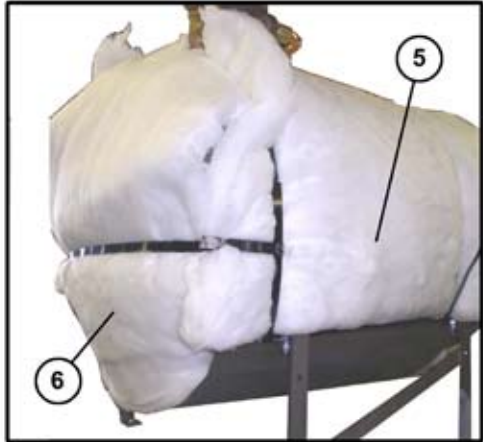
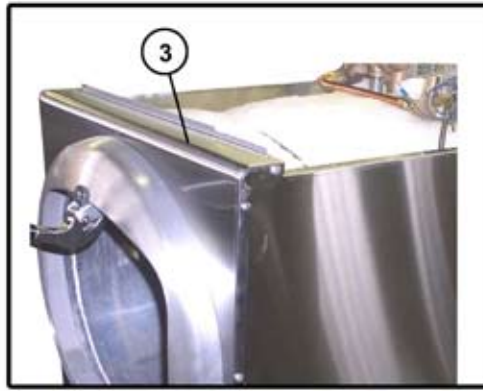
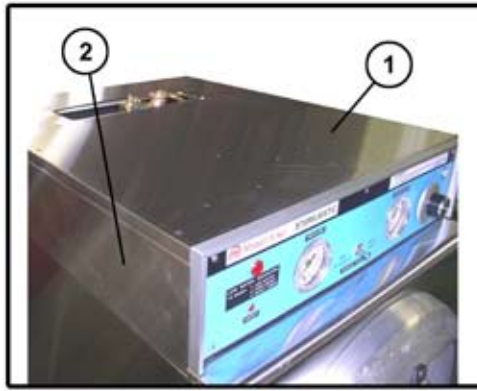

ITEM	ALL MODELS		DESCRIPTION
	QTY.	PART NO.	
1	1	95-2558	Flue Cover Assy.
2	1	95-2652	Flue Outer Case Wrap
3	1	95-2650	Upper Case, Front
4	1	95-2616	Lower Case, Front
5	1	10-6363	Insulation, Body
6	1	10-6365	Insulation, Back
7	1	10-6364	Insulation, Bottom
8	1	95-0465	Bottom Cover for Elements
9	1	95-2628	Cylinder, 208V - 240V (Shown with Door Assy.)

SECTION 6 ILLUSTRATED PARTS



ITEM	ALL MODELS		DESCRIPTION
	QTY.	PART NO.	
1	1	95-3196	Outside Case, Left Side
2	1	95-3195	Outside Case, Right Side
3	1	95-3194	Outside Case, Back
4	1	10-0226	Handle Bumper
5	1	95-3484	Terminal Box Cover
6	2	95-2545	Pan Rack, 1 Left & 1 Right
7	1	95-2637	Condensate Baffle, Upper
8	1	95-3207	Perforated Water (<i>Splash</i>) Baffle
9	4	95-3284	Wear Strip

SECTION 6 ILLUSTRATED PARTS

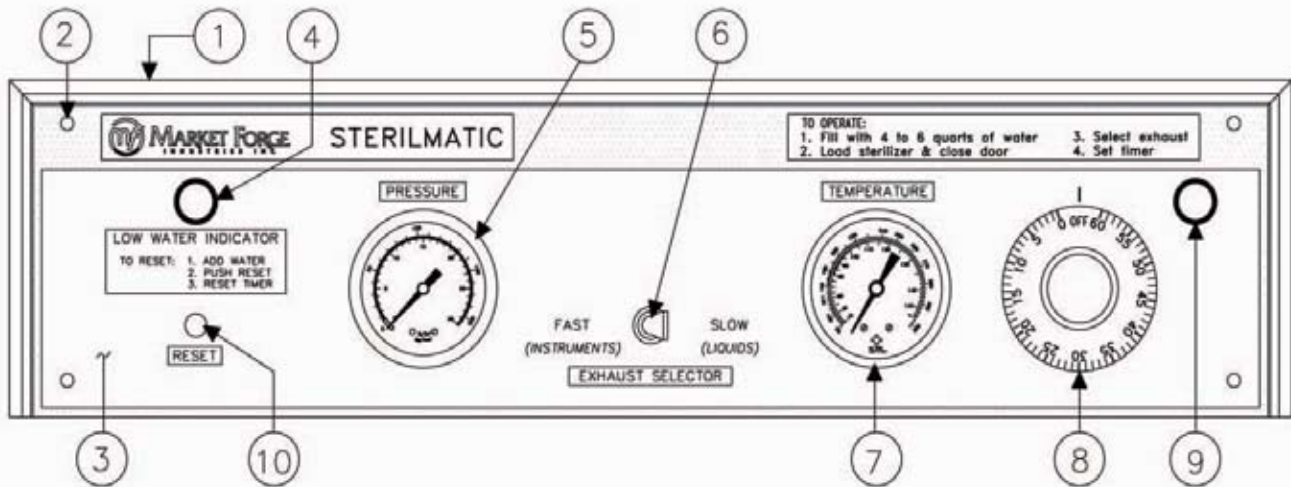

STM-E & STM-EX

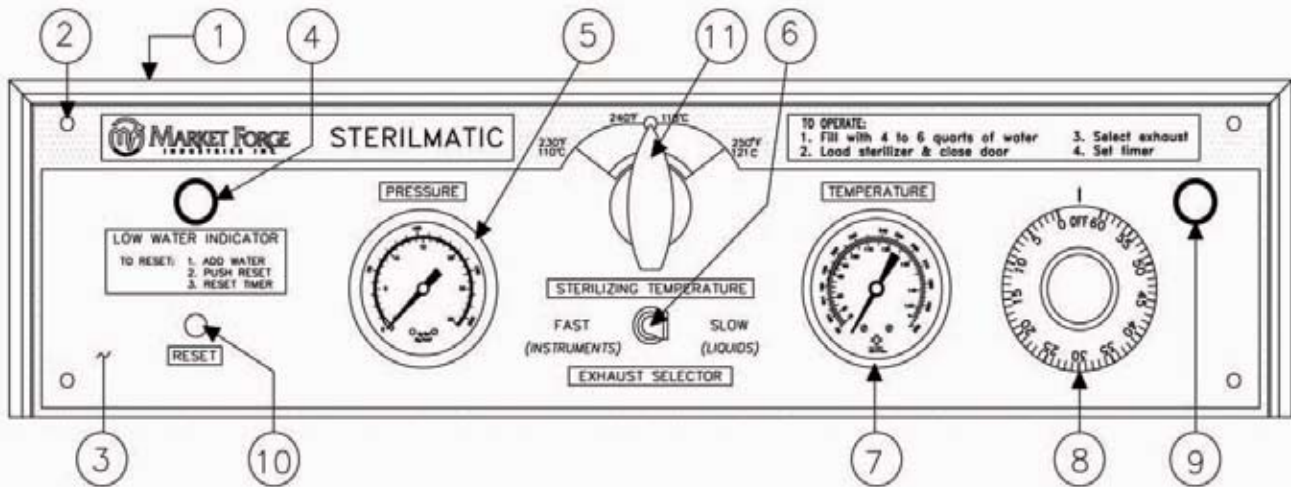

STM-EL & STM-ELX

CONTROL PANELS

ITEM	STM-E PART NO.	STM-EX PART NO.	STM-EL PART NO.	STM-ELX PART NO.	DESCRIPTION
1	10-0489	-	10-0489	-	Bezel
2	10-1722	-	10-1722	-	Round Head Machine Screw, 6-32
3	10-9280	-	10-9279	-	Control Panel
4	10-5052	10-6669	10-5052	10-6669	Pilot Light, Red
5	10-9267	10-9271	10-9267	10-9271	Pressure Gauge
6	10-5999	-	10-5999	-	Switch
7	10-9268	-	10-9268	-	Temperature Gauge
8	10-0189	-	10-0189	-	Timer Knob
9	10-5940	10-6876	10-5940	10-6876	Pilot Light, White
10	10-5990	-	10-5990	-	Low Water Cut-Off
11	-	-	10-0051	-	Knob

SECTION 6 ILLUSTRATED PARTS

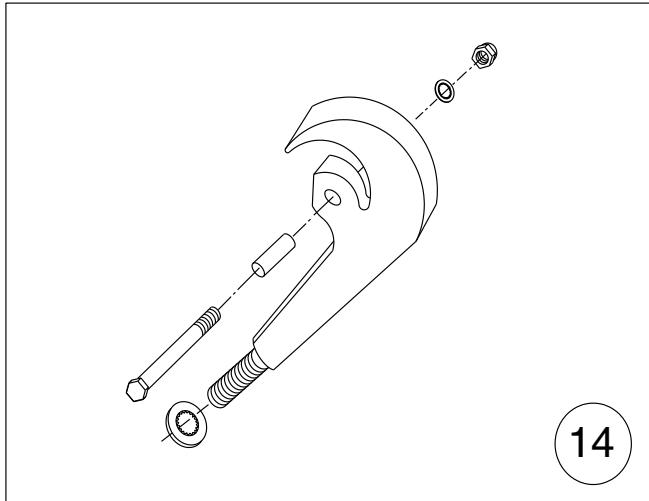

14

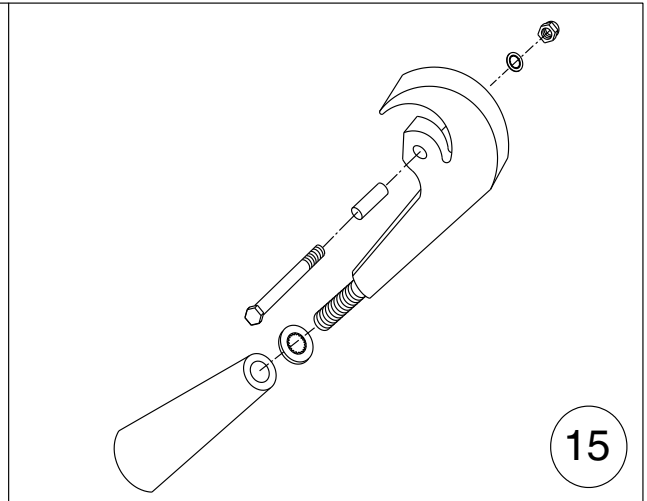

15

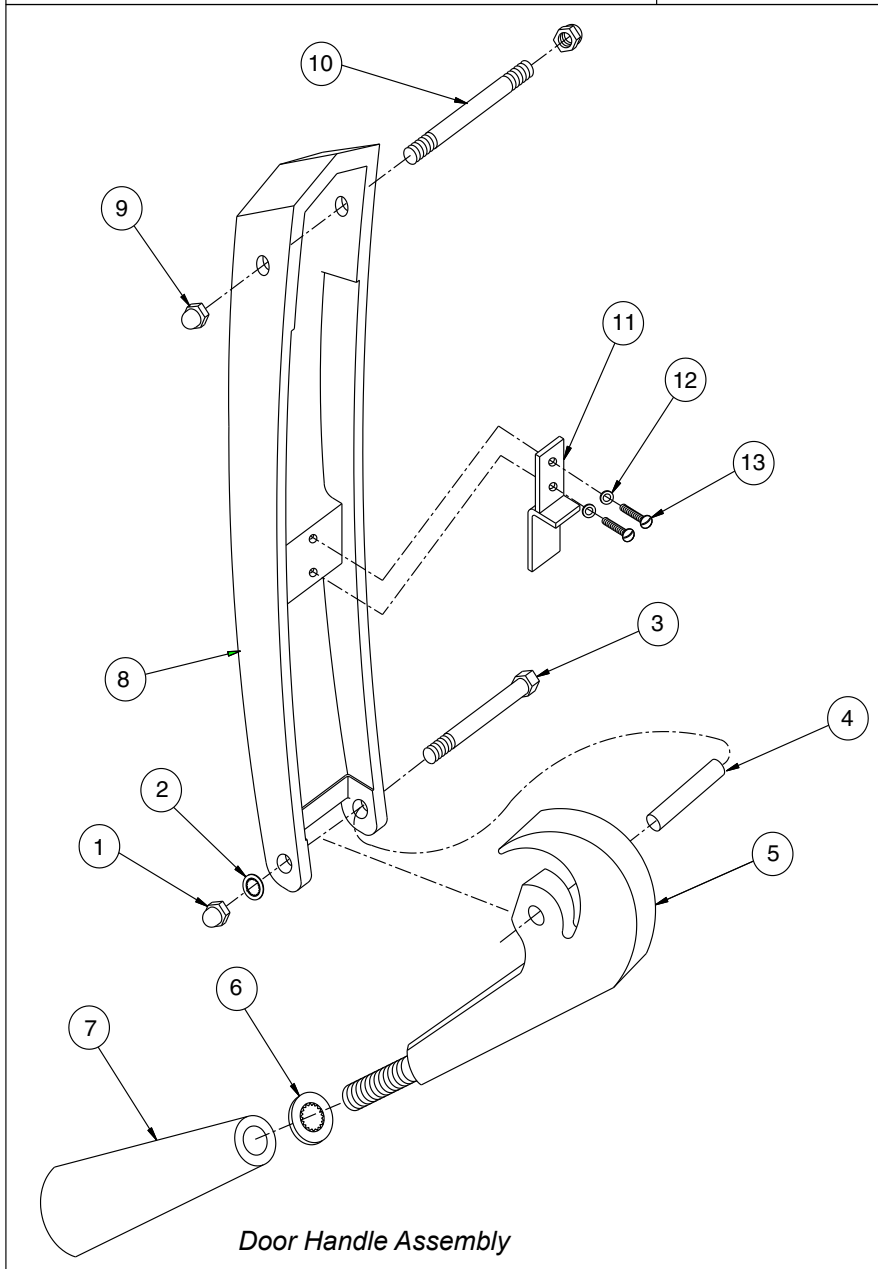

Door Handle Assembly

16

SECTION 6 ILLUSTRATED PARTS

DOOR HANDLE ASSEMBLY

ITEM	PART NO.	DESCRIPTION
1	10-2318	10-32 Acorn Nut
2	10-2514	#10 Shakeproof Lockwasher
3	95-0571	10-32 Machine Screw 1 3/8" Lg.
4	95-0120	Bearing Spacer
5	95-0136	Door Lock Casting
6	10-2517	3/8" Shakeproof Lockwasher
7	10-0050	Door Lock Knob
8	95-0134	Door Handle Casting
9	10-2359	1/4"-20 Acorn Nut
10	95-0658	Door Handle Bearing Stud
11	95-0659	Door Handle Bearing Plate
12	10-2513	1/4" Shakeproof Lockwasher
13	10-1731	1/4"-20 Machine Screw 5/8" Lg.
14	95-0190	Door Lock Casting Assy. (<i>Items 1 through 6</i>)
15	95-0145	Door Lock Knob Assy. (<i>Items 1 through 7</i>)
16	95-0144	Complete Door Handle Assy. (<i>Items 1 through 13</i>)
17	95-0198	Handle Bushing (<i>Not Shown</i>)

SECTION 6 ILLUSTRATED PARTS

MISCELLANEOUS PARTS (*NOT SHOWN*)

STM-E(L)		STM-E(L)X		DESCRIPTION
QTY.	PART NO.	QTY.	PART NO.	
1	95-2606			Temperature Recorder, 120 V (<i>Optional</i>)
		1	10-5343	Temperature Recorder, 240 V (<i>Optional</i>)
1	20-0316	-	-	Replacement Probe (<i>For Recorder</i>)
1	95-2653	-	-	Upper Mounting Plate
1	10-5788	-	-	120v, 50/60 Hz Cycle Coil
1	95-3552	-	-	Wire Harness, Flue Assy.
1	95-3553	-	-	Wire Harness, Contactors

SECTION 7 TROUBLE-SHOOTING

STEAM TRAP TROUBLE-SHOOTING:

Trouble can only occur either through the premature closing of the steam trap before all the cold air has been exhausted, or by its failure to close sufficiently to enable a proper steam pressure build-up. Either case warrants a replacement of the thermostatic element.

TROUBLE	POSSIBLE CAUSE	CORRECTION
Sterilizer fails to operate at all (<i>no pressure build up</i>).	<ol style="list-style-type: none"> 1. Not installed correctly. 2. Blown fuse. 3. Contactor burned out. 4. Wiring is defective. 	<ol style="list-style-type: none"> 1. Check wire diagram for correct hook up. 2. Replace fuse. If it blows, check that source of electric supply is 60 amps. 3. Replace. 4. Check all wiring. Repair or replace.
Sterilizer operates, but fails to build up 15.5 PSI pressure.	<ol style="list-style-type: none"> 1. Current not heating all of the elements. 2. Steam trap fails to close. 3. Exhaust valve fails to hold pressure at 15.5 PSI. 4. Steam leaks around door. 5. Safety valve blows-off prematurely. 	<ol style="list-style-type: none"> 1. Remove lower front panel and see if the heating elements are working. 2. Replace the thermometer within the steam trap. 3. Check for incorrect adjustment on temperature control. Readjust. 4. Check for worn gasket or make door adjustment. 5. Replace safety valve.
Unit releases pressure before cycle has terminated on timer.	<ol style="list-style-type: none"> 1. Low water cut-off has functioned prematurely. 	<ol style="list-style-type: none"> 1. Replace low water cut-off.
Timer is erratic, or fails to return to zero.	<ol style="list-style-type: none"> 1. Loose or broken electrical leads on timer. 	<ol style="list-style-type: none"> 1. Repair defective wiring.
Unable to obtain set temperature at peak of cycle.	<ol style="list-style-type: none"> 1. Steam trap closing prematurely, preventing removal of air from the chamber. 	<ol style="list-style-type: none"> 1. Replace the thermostatic element in the steam trap.
One or both sides of the cast-in heating elements remain on when the timer is in an OFF position.	<ol style="list-style-type: none"> 1. Contactors of the temperature control switch remains closed. 2. Temperature control not properly calibrated. 	<ol style="list-style-type: none"> 1. Replace switches. 2. Recalibrate.
Heating element cutting out before 15 lbs. of pressure is reached.	<ol style="list-style-type: none"> 1. Pressure cutting off at the temperature control too soon. 	<ol style="list-style-type: none"> 1. See adjusting the range of operation and calibration of the temperature control. Readjust.

SECTION 8 WARRANTY INFORMATION

STERILIZER (AUTOCLAVE) WARRANTY

MODELS: STM-E, STM-EL, STM-EX* and STM-ELX*

We warrant to the original purchaser that the sterilizers manufactured by Market Forge Industries, Inc. will be free from defects in material and factory workmanship if properly installed and operated under normal conditions. Within one year from date of original installation, or within 15 months from date of shipment from factory, whichever is sooner, we will repair or replace that part of any such machine that becomes defective at no cost to the customer.

This warranty is effective for One (1) Year Parts and 90 Days Labor, Travel and Mileage.

This warranty does not apply to damage resulting from use of hard or corrosive water, from failure to drain and dry cylinder daily or from inadequate cleaning procedures. Nor does it cover any part or assembly, which has been subjected to accident, alteration, or is from a machine where the serial number has been removed or altered. Normal service adjustments are not covered by this warranty.

Any defect during the warranty period shall be brought to the attention of a factory authorized service agency or the dealer from whom the equipment was purchased. He will be authorized to furnish or arrange for repairs or replacements within the terms of the warranty.

PLEASE NOTE: This warranty only applies to the USA and Canada. Elsewhere, warranty covers parts only for one year as described above.

* *Export Model.*



Market Forge Ind., Inc.
35 Garvey Street
Everett, Massachusetts
02149 - 4403

Tel: (617) 387-4100
(866) 698-3188
Fax: (617) 387-4456
(800) 227-2659

custser@mfi.com
www.mfii.com