

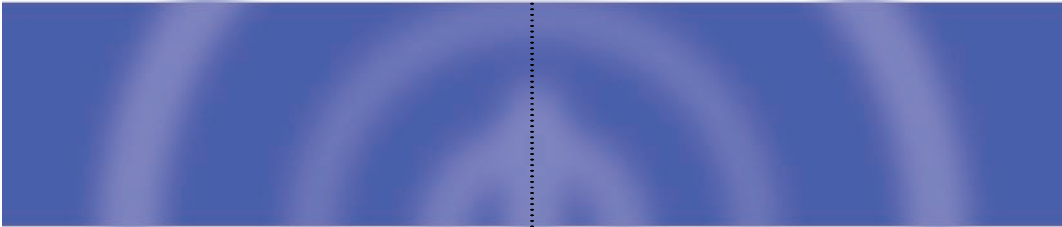

MERIDIAN DSP
LOUDSPEAKER
USER GUIDE



Meridian DSP Loudspeaker User Guide



Important safety instructions

- Read the instructions.
- Keep these instructions.
- Follow all instructions.
- Do not use this apparatus near water.
- Clean only with a dry cloth.
- Install only in accordance with the manufacturer's instructions.
- Refer all servicing to approved service personnel.

Safety warnings

WARNING: TO REDUCE THE RISK OF FIRE OR ELECTRIC SHOCK, DO NOT EXPOSE THIS APPARATUS TO RAIN OR MOISTURE

- Do not expose the speakers to dripping or splashing.
- Do not place any object filled with liquid, such as a vase, on the speakers.
- Do not place naked flame sources, such as lighted candles, on the speakers.

To avoid overheating

- Leave at least 10cm around the equipment to ensure sufficient ventilation.

Do not position the unit:

- In direct sunlight.
- Near heat sources, such as a radiator.
- Directly on top of heat producing equipment, such as a power amplifier.

To avoid interference

Do not position the unit:

- Near strong magnetic radiation.
- Near to a television, or where connecting cables may be subject to or cause interference.

Radio interference

FCC Warning: This equipment generates and can radiate radio frequency energy and if not installed and used correctly in accordance with our instructions may cause interference to radio communications or radio and television reception. It has been type-tested and complies with the limits set out in Subpart J, Part 15 of FCC rules for a Class B computing device. These limits are intended to provide reasonable protection against such interference in home installations.

EU: This product has been designed and type-tested to comply with the limits set out in EN55013 and EN55020.



.....

Contents

.....

Introduction	1
Meridian DSP loudspeakers	2
Sample configurations	5
Available accessories	6
DSP5000 and DSP5000C	7
Unpacking	8
Specifications	10
DSP5200 and DSP5200HC	13
Unpacking	14
Specifications	17
DSP5500, DSP5500HC, and DSP5500C	19
Unpacking	20
Specifications	22
DSP6000 and DSP6000C	25
Unpacking	26
Specifications	29
DSP7000	31
Unpacking	32
Specifications	34
Connecting up the DSP loudspeakers	37
Connecting the loudspeakers	38
Connecting to other equipment	40
Positioning the digital loudspeakers	43

Using the DSP loudspeakers	45
Selecting a source	46
Changing the display	47
Adjusting the volume	48
Changing the treble, bass, or phase	49
Changing the listening position	50
Configuring the DSP loudspeakers	51
Choosing standard settings	52
Specifying information about your system	54
Configuring the sources	55
Configuring the setup options	57
Troubleshooting	59
Troubleshooting	60
Cleaning	62
Service and guarantee	63
Index	65

.....

Copyright and acknowledgements

Sales and service in the UK

Meridian Audio Ltd
 Latham Road
 Huntingdon
 Cambridgeshire
 PE29 6YE
 England

Tel (01480) 445678
 Fax (01480) 445686

Sales and service in the USA

Meridian America Inc
 8055 Troon Circle
 Suite C
 Austell
 GA30168-7849
 USA

Tel (404) 344 7111
 Fax (404) 346 7111

World Wide Web – <http://www.meridian-audio.com>

Designed and manufactured in the UK by

Meridian Audio Ltd
 Latham Road
 Huntingdon
 Cambridgeshire
 PE29 6YE
 England

Copyright © 2002-2005 Meridian Audio Ltd.
 Part no: DSPU/4 (P80504)

Boothroyd|Stuart Meridian, Meridian,
 Meridian Digital Theatre, Meridian
 Lossless Packing, MHR and MLP are
 registered trademarks of Meridian
 Audio Ltd.

This guide was produced by:
 Human-Computer Interface Ltd,
<http://www.interface.co.uk>

MHR: This product incorporates
 copyright protection technology covered
 by certain patent applications and
 intellectual property of Meridian Audio
 Ltd. This technology is provided for the
 express purpose of securely containing
 copyright audio within the Meridian
 System only. Reverse engineering or
 circumvention of this protection is
 strictly prohibited.

.....

.....



.....

Introduction

.....

Welcome to the Meridian DSP loudspeaker range.

**This User Guide provides full information about using the DSP
loudspeakers in conjunction with your other equipment, to achieve the
superb results you can expect from them.**



Meridian DSP loudspeakers

Meridian DSP loudspeakers represent the fruits of more than 25 years of continuous development of loudspeakers as musical instruments. The finest materials and state-of-the-art design are combined to create what we believe is the ultimate range of home loudspeakers.

Digital Signal Processing

Digital Signal Processing, or DSP, is a technique pioneered by Meridian in hi-fi products for achieving extremely accurate reproduction of audio signals using high-precision mathematical processing.

DSP allows sophisticated processing to be performed without any of the cumulative noise or degradation that inevitably occurs, even with high-quality analogue circuitry. In addition, the signal improvement techniques incorporated in the Meridian DSP loudspeakers would be virtually impossible to implement in the analogue domain.

The Meridian DSP loudspeakers take advantage of DSP for several different functions:

- To remove timing variations from the incoming digital signals (de-jittering).
- To split the audio frequency band between bass, mid-range, and treble drivers (crossover).
- To perform filtering or adjustment of the frequency response; eg treble or bass.
- To provide volume control to 48-bit precision.
- To provide digital protection of the loudspeakers against high-level low-frequency transients.
- To perform electronic equalisation.

If you are using the Meridian DSP loudspeakers with a digital source, such as CD or DVD, the signals remain in digital form until the last possible stage.

DSP loudspeaker drivers

Each DSP loudspeaker uses multiple high-efficiency long-throw custom drive bass units.

Each treble unit is a very high quality 25mm (1") Meridian piston in a short horn, using an aluminium dome with a silver voice-coil. It is extremely well matched to the woofers, and also tonally very compatible with the other drivers employed in the Meridian range.

Power amplifiers

The speakers are driven by multiple independent high-power, low-feedback power amplifiers. The combination of idealised magnetic design, careful star earthing, and very fast output devices gives the amplifiers extremely low noise, high detail, and fast bass.

The whole electronic assembly is supplied from substantial toroidal transformers feeding high-quality, audiophile-grade capacitors.

Cabinet

Each DSP loudspeaker is carefully designed with internal bracing and damping to give incredibly low levels of cabinet resonance, resulting in low coloration and excellent mid-range transparency.

The DSP5200 and DSP5200HC are constructed using veneered ply, braced and resin damped to produce an ultra-rigid cabinet.

The DSP5500, DSP5500C, and DSP5500HC are constructed using thick veneered MDF sides bolted through a 1.5mm steel plate onto the main cabinet, giving extremely low levels of cabinet resonance and excellent bass-mid isolation.

In the DSP6000 and DSP6000C the bass drivers are mounted symmetrically in pairs on the sides of the cabinet, cancelling vibration and giving exceptionally low levels of cabinet resonance. The mid-range and treble drivers are housed in a separate interlaminated head, to minimise bass-mid interference. It is supported on the bass enclosure by three machined feet.

The DSP7000 cabinet is fabricated from curved pressure-laminated panels, using multiple layers of selected woods and metal to achieve high stiffness and damping. Its narrow tapered shape gives optimum dispersion over a wide listening area. Each cabinet stands on three adjustable machined feet which can be fitted with spikes or skids.

Mounting options

In addition to the main vertical speakers, designed for use as the left/right speakers in a system, each model includes a single horizontal centre and/or a single vertical centre, designed for use as the centre speaker in a surround system.

The DSP5000C, DSP5200HC, and DSP5500HC are horizontal centre versions, designed for use either above or below a television.

The DSP5500C and DSP6000C are vertical versions, designed for use as centre speakers, and they use fully shielded drive units so they can be placed next to a television without interference.

Meridian High Resolution (MHR)

All Meridian DSP loudspeakers support Meridian High Resolution (MHR), to allow you to connect to other MHR-compliant Meridian products to take advantage of high-rate audio sources, and provide the additional benefits of lower jitter and improved sound quality on all sources.

MHR is a proprietary secure encoding format that uses encryption and anti-copy methods to provide a secure copyright protection environment, and allow the secure transfer of audio streams within a Meridian-only system for playback only.

Meridian Comms

Meridian DSP loudspeakers are part of the Meridian family of advanced digital, analogue, and video components, and these incorporate a sophisticated communications link, to allow you to control any combination of units using a single remote, and ensure that they will work together as a fully integrated system.

The communications system also allows you to extend your hi-fi system into two or three rooms, with the ability to control the sources in one room from the controller in another room.

The following shows two recommended configurations based on the Meridian DSP loudspeakers to illustrate the flexibility of Meridian components.

Sample configurations

Meridian Digital Theatre™

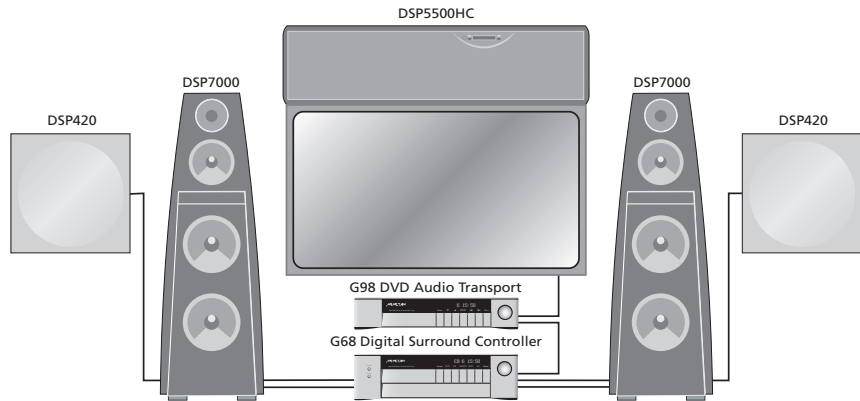

Up to seven Meridian DSP loudspeakers can be used in conjunction with a Meridian Surround Processor, such as the G68 Digital Surround Controller, to create a digital surround system with superb music and cinema sound.

The G98 DVD Audio Transport is an ideal source for use with DSP loudspeakers. It allows you to play audio CDs, DVD-Audio discs, and DVD-Video discs, with the audio kept in digital form until the last possible stage.

Meridian Digital Music System

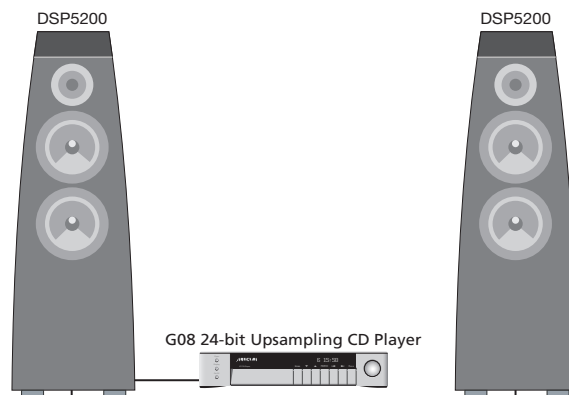

Meridian DSP loudspeakers include DSP volume and tone controls, and can be connected directly to up to two digital sources, such as the G08 24-bit Upsampling CD Player, to create an extremely compact high-quality music system.

Available accessories

Each DSP loudspeaker is shipped complete with cables to enable it to be used in a Meridian Digital music system. In addition, each pair of main loudspeakers is supplied with a MSR+ remote.

Other applications, and some advanced features, may require one or more of the following accessories, which can be purchased from your Meridian dealer:

- Additional S5 leads (8m and 14m).
- 511 S-patch box if connecting more than two DSP loudspeakers to a G68 Digital Surround Controller (not required with 861).



DSP5000 and DSP5000C

This chapter explains how to unpack and install the DSP5000 and DSP5000C, and gives specifications.

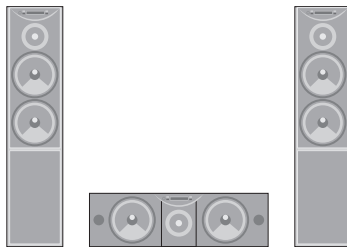

Unpacking

Before you begin installation you should ensure that your DSP loudspeakers are the correct voltage for your local AC supply. If they are not, do not try to install them, and contact your dealer.

You should not make any connections to the DSP loudspeakers, or to any other component in your system, while the AC power supply is connected and switched on.

Care when unpacking

Take great care when unpacking or repacking the DSP loudspeakers that you do not put undue pressure on the face containing the drive units, as they may be damaged if pressed.

Components

Each pair of DSP loudspeakers is supplied with the following components:

- The DSP loudspeakers complete with grilles.
- A hex wrench (3mm) for the drive units.
- Eight screw-in spikes with lock nuts and protectors together with a wrench for fitting them (DSP5000 only).
- Eight rubber bumpons (DSP5000C only).
- MSR+ remote, battery and user guide.
- One power cord per speaker.
- Meridian M5 lead (8m).
- Meridian S5 lead (8m).
- This user guide.

If any of these items is missing please contact your dealer. We suggest that you retain the packaging carefully for maximum protection in transit.

To fit the feet (DSP5000 only)

The feet ensure that the loudspeakers have a stable base, and can be adjusted to allow for uneven floors. Use the spikes for carpeted floors; they are designed to penetrate the pile without damaging or flattening the carpet. Use the protectors for solid floors.

Each DSP loudspeaker needs four feet, fitted as follows:

- Fit a lock nut to each foot, leaving about 2mm of thread between the lock nut and foot.
- Screw each foot into the threads on the bottom of the loudspeaker. Do not fully tighten the lock nut at this stage.

- On solid floors fit the protectors over the spikes.
- When all four feet have been fitted, carefully set the DSP loudspeakers upright in their playing positions and remove the rest of the packaging.
- Adjust the feet until the speakers are stable, and then tighten the lock nuts.

To fit the rubber bumpons (DSP5000C only)

- Attach four bumpons to the underside of each speaker, using the self-adhesive pads.

Tightening the drive units

The DSP loudspeakers typically take about two weeks of normal use for the drive units to settle. It is therefore recommended that you tighten the mounting bolts on each drive unit every few days during this period. Tighten the bolts in symmetrically opposite pairs using the 3mm hex wrench supplied.

You should then check and if necessary retighten the drive units every few years.

Specifications

Digital inputs and outputs

- 2 x cable inputs, 32–96kHz. FIFO locks at 44.1, 48, 88.2, or 96kHz ± 150 ppm.
- PCM using IEC958, or MHR connection support with auto-detection.
- 1 x cable input pass-through to feed second speaker.

Signal processing

- 1 x Motorola 56303 running at 80MHz.
- 2 x 24-bit Multi-bit delta-sigma DACs with 128x oversampling.
- Crossover linear-phase $\pm 30^\circ$ at 2.3kHz.

Output stages

- Power amplifiers: Complementary bipolar design, with output-stage error correction and twin loop design.
- Bass: 2 x 75W.
- Treble: 75W.

Acoustic

- $2\frac{1}{2}$ way.
- Ported bass enclosure.
- Bass/Mid drive units: 2 x 160mm (6") polypropylene high-efficiency long-throw custom drivers.
- Treble drive unit: 1 x 25mm (1") Meridian piston in short horn, aluminium dome with silver voice-coil.

Characteristics

- Distortion typically $<0.01\%$, or $<0.02\%$ up to full power at all frequencies.
- Noise and hum <-94 dBr at all volume settings.
- Acoustic output typically >108 dB spl @ 1m.
- Acoustic noise <15 dB spl @ 1m.
- Frequency response in room response within 3dB, 35Hz-20kHz.

Control

- 2 x Meridian Comms.
- 9-pin D connector for RS232 PC control, null modem, 9600 baud, 2N1, no handshake.

Cabinet

- Wood-veneered MDF with internal bracing and damping.
- Available in black ash, rosewood, or cherry.
- DSP5000: 210mm x 900mm x 297mm (8.3" x 35.4" x 11.7") (W x H x D).
- DSP5000C: 670mm x 195mm x 275mm (26.3" x 7.7" x 10.8") (W x H x D).
- 32kg (70lb) each.

Power

- 100-125; 200-250V AC 50-60Hz.
- 20VA standby; 300VA max.

Meridian Audio reserves the right to amend product specifications at any time.

.....

.....



DSP5200 and DSP5200HC

This chapter explains how to unpack and install the DSP5200 and DSP5200HC, and gives specifications.

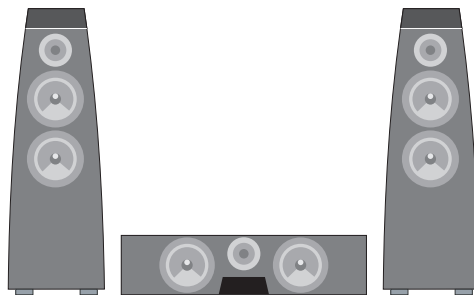

Unpacking

Before you begin installation you should ensure that your DSP loudspeakers are the correct voltage for your local AC supply. If they are not, do not try to install them, and contact your dealer.

You should not make any connections to the DSP loudspeakers, or to any other component in your system, while the AC power supply is connected and switched on.

Care when unpacking

Take great care when unpacking or repacking the DSP loudspeakers that you do not put undue pressure on the face containing the drive units, as they may be damaged if pressed.

Components

Each pair of DSP loudspeakers is supplied with the following components:

- The DSP loudspeakers complete with grilles.
- A hex wrench (3mm) for the drive units.
- Eight screw-in feet with retractable spikes (DSP5200 only).
- Eight rubber bumpons (DSP5200HC only).
- MSR+ remote, battery and user guide.
- One power cord per speaker.
- Meridian M5 lead (8m).
- Meridian S5 lead (8m).
- This user guide.

If any of these items is missing please contact your dealer. We suggest that you retain the packaging carefully for maximum protection in transit.

Caution

Meridian Audio has taken every care in the design, assembly, finishing and packing of this product. Some models include a high-gloss finish, which is achieved by painting up to five coats of polyester lacquer onto the plywood, each one hand polished.

Due to the product size and high technology cabinet construction, small marks on the lacquer surface may be visible when unpacked. These small marks can usually be removed as described in *Cleaning*, page 62.

It is the nature of all lacquer finishes to shrink over time. This is unavoidable and may result in cabinet joint lines becoming visible.

Meridian Audio has supplied products using lacquer finishes for many years and we are confident that when carefully used your product will return a lifetime's enjoyment.

To fit the feet (DSP5200 only)

The feet ensure that the loudspeakers have a stable base, and can be adjusted to allow for uneven floors. Use the spikes for carpeted floors; they are designed to penetrate the pile without damaging or flattening the carpet. Retract the spikes for solid floors.

Each DSP loudspeaker needs four feet, fitted as follows:

- Insert the spike into the foot so that the nut engages in the hexagonal recess in the bottom of the foot, and screw each spike into the threads on the bottom of the loudspeaker. Do not fully tighten the lock nuts at this stage.
- On solid floors retract the spike so it does not extend below the foot cap.
- When all four feet have been fitted, carefully set the DSP loudspeakers upright in their playing positions and remove the rest of the packaging.
- On carpeted floors, adjust the spikes until the speakers are stable, and then tighten the lock nuts using the feet as wrenches. If you need additional length on the spikes you can remove the feet and use the spikes and lock nuts on their own.

To fit the rubber bumpons (DSP5200HC only)

- Attach four bumpons to the underside of each speaker, using the self-adhesive pads.

Tightening the drive units

The DSP loudspeakers typically take about two weeks of normal use for the drive units to settle. It is therefore recommended that you tighten the mounting bolts on each drive unit every few days during this period. Tighten the bolts in symmetrically opposite pairs using the 3mm hex wrench supplied.

You should then check and if necessary retighten the drive units every few years.

Removing the grilles

The grilles are deliberately designed to fit tightly to avoid vibration during operation, and they should be removed using the following procedure to avoid damaging the loudspeaker.

The grille consists of elastic material stretched tightly over a plastic ring. The plastic ring includes two indentations at the three o'clock and nine o'clock positions, which you can locate by gently depressing the grille fabric.

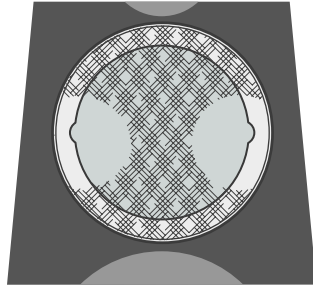

Hold the ring by one of the indentations by depressing the grille fabric with your thumb, and then wiggle the ring forwards until it comes free of the speaker. The grille fabric is very resilient and any depressions will soon disappear.

Note: On no account attempt to remove the grille with a hard object, or attempt to lever it out from the outside edge, as you will damage the edge of the speaker surround and the grille itself.

Specifications

Digital inputs and outputs

- 2 x cable inputs, 32–96kHz. FIFO locks at 44.1, 48, 88.2, or 96kHz ± 150 ppm.
- PCM using IEC958, or MHR connection support with auto-detection.
- 1 x 24-bit Multi-bit delta-sigma DACs with 128x oversampling.

Signal processing

- 2 x Motorola 56367 running at 150MHz.
- 4 x 24-bit Multi-bit delta-sigma DACs with 128x oversampling.
- Crossover linear-phase $\pm 30^\circ$ at 2.6kHz.

Output stages

- Power amplifiers: Complementary bipolar design, with output-stage error correction and twin loop design.
- Bass: 2 x 75W.
- Treble: 75W.

Acoustic

- $2\frac{1}{2}$ way.
- Ported bass enclosure.
- Isolated mid enclosure.
- Bass drive unit: 2 x 160mm (6") custom polypropylene driver using phase plug.
- Treble drive unit: 1 x 25mm (1") Meridian piston in short horn, aluminium dome with silver voice-coil.

Characteristics

- Distortion typically $< 0.02\%$ up to full power at all frequencies.
- Noise and hum < -94 dB at all volume settings.
- Acoustic output typically > 108 dB spl @ 1m.
- Acoustic noise < 15 dB spl @ 1m.
- Frequency response in room response within 3dB, 35Hz-20kHz.

Control

- 2 x Meridian Comms.
- 9-pin D connector for RS232 PC control, null modem, 9600 baud, 2N1, no handshake.
- 8-character display with system lights.

Cabinet

- Entire speaker manufactured from interlaminated panels.
- Individually covered grilles for bass units.
- Finished in black or silver high-gloss lacquer, satin Santos rosewood, natural stain maple, black ash, or cherry.
- DSP5200: 300mm x 903mm x 356mm (11.8" x 35.6" x 14.0") (W x H x D).
- DSP5200HC: 735mm x 201mm x 267mm (29.0" x 7.9" x 10.5") (W x H x D).
- 35kg (77lb) each.

Power

- 100-125; 200-250V AC 50-60Hz.
- 20VA standby; 600VA max.

Meridian Audio reserves the right to amend product specifications at any time.



DSP5500, DSP5500HC, and DSP5500C

This chapter explains how to unpack and install the DSP5500, DSP5500HC, and DSP5500C, and gives specifications.

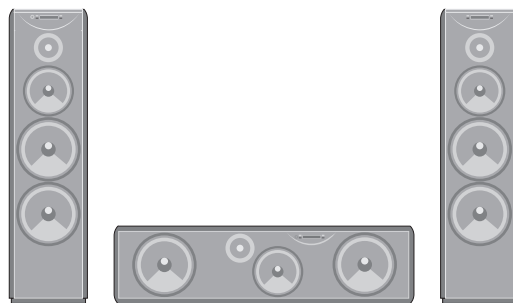

Unpacking

Before you begin installation you should ensure that your DSP loudspeakers are the correct voltage for your local AC supply. If they are not, do not try to install them, and contact your dealer.

You should not make any connections to the DSP loudspeakers, or to any other component in your system, while the AC power supply is connected and switched on.

Care when unpacking

Take great care when unpacking or repacking the DSP loudspeakers that you do not put undue pressure on the face containing the drive units, as they may be damaged if pressed.

Components

Each pair of DSP loudspeakers is supplied with the following components:

- The DSP loudspeakers complete with grilles.
- A hex wrench (3mm) for the drive units.
- A hex wrench (8mm) for the side panels.
- Eight screw-in spikes with lock nuts and protectors together with a wrench for fitting them (DSP5500 and DSP5500C only).
- Eight rubber bumpons (DSP5500HC only).
- MSR+ remote, battery and user guide.
- One power cord per speaker.
- Meridian M5 lead (8m).
- Meridian S5 lead (8m).
- This user guide.

If any of these items is missing please contact your dealer. We suggest that you retain the packaging carefully for maximum protection in transit.

To fit the feet (DSP5500 and DSP5500C only)

The feet ensure that the loudspeakers have a stable base, and can be adjusted to allow for uneven floors. Use the spikes for carpeted floors; they are designed to penetrate the pile without damaging or flattening the carpet. Use the protectors for solid floors.

Each DSP loudspeaker needs four feet, fitted as follows:

- Fit a lock nut to each foot, leaving about 2mm of thread between the lock nut and foot.

- Screw each foot into the threads on the bottom of the loudspeaker. Do not fully tighten the lock nut at this stage.
- On solid floors fit the protectors over the spikes.
- When all four feet have been fitted, carefully set the DSP loudspeakers upright in their playing positions and remove the rest of the packaging.
- Adjust the feet until the speakers are stable, and then tighten the lock nuts.

To fit the rubber bumpons (DSP5000HC only)

- Attach four bumpons to the underside of each speaker, using the self-adhesive pads.

Tightening the drive units

The DSP loudspeakers typically take about two weeks of normal use for the drive units to settle. It is therefore recommended that you tighten the mounting bolts on each drive unit every few days during this period. Tighten the bolts in symmetrically opposite pairs using the 3mm hex wrench supplied.

You should then check and if necessary retighten the drive units every few years.

Removing the grilles

The DSP5500 grille frame has been designed to be as acoustically transparent as possible, and is quite fragile. When removing the grille, ease it carefully off by hand from the bottom and sides, avoiding excessive bending of the frame.

Specifications

Digital inputs and outputs

- 2 x cable inputs, 32–96kHz. FIFO locks at 44.1, 48, 88.2, or 96kHz \pm 150ppm.
- PCM using IEC958, or MHR connection support with auto-detection.
- 1 x 24-bit Multi-bit delta-sigma DACs with 128x oversampling.

Signal processing

- 2 x Motorola 56303 running at 80MHz.
- 4 x 24-bit Multi-bit delta-sigma DACs with 128x oversampling.
- Crossover linear-phase $\pm 30^\circ$ at 200Hz and 2.6kHz.

Output stages

- Power amplifiers: Complementary bipolar design, with output-stage error correction and twin loop design.
- Bass: 2 x 75W.
- Mid: 75W.
- Treble: 75W.

Acoustic

- 3 way.
- Ported bass enclosure.
- Isolated mid enclosure.
- Bass drive unit: 2 x 200mm (8") high-efficiency long-throw custom drivers.
- Mid drive unit: 1 x 160mm (6") custom polypropylene driver using phase plug.
- Treble drive unit: 1 x 25mm (1") Meridian piston in short horn, aluminium dome with silver voice-coil.

Characteristics

- Distortion typically <0.01%, or <0.02% up to full power at all frequencies.
- Noise and hum <-94dBr at all volume settings.
- Acoustic output typically >111dB spl @ 1m.
- Acoustic noise <15dB spl @ 1m.
- Frequency response in room response within 3dB, 28Hz-20kHz.

Control

- 2 x Meridian Comms.
- 9-pin D connector for RS232 PC control, null modem, 9600 baud, 2N1, no handshake.

Cabinet

- Thick MDF side panels sandwiched around steel plates for maximum damping across all frequencies.
- Steel plates give magnetic shielding.
- Side panels available in black ash and rosewood.
- Separate mid-range enclosure built into main cabinet.
- DSP5500 and DSP5500C: 284mm x 1100mm x 450mm (11.2" x 43.3" x 17.7") (W x H x D).
- DSP5500HC: 1100mm x 285mm x 415mm (43.3" x 11.2" x 16.3") (W x H x D).
- 65kg (143lb) each.

Power

- 100-125; 200-250V AC 50-60Hz.
- 20VA standby; 600VA max.

Meridian Audio reserves the right to amend product specifications at any time.

.....

.....

.....



DSP6000 and DSP6000C

This chapter explains how to unpack and install the DSP6000 and DSP6000C, and gives specifications.

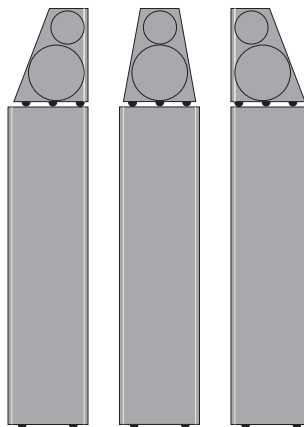

Unpacking

Before you begin installation you should ensure that your DSP loudspeakers are the correct voltage for your local AC supply. If they are not, do not try to install them, and contact your dealer.

You should not make any connections to the DSP loudspeakers, or to any other component in your system, while the AC power supply is connected and switched on.

Care when unpacking

Take great care when unpacking or repacking the DSP loudspeakers that you do not put undue pressure on the face containing the drive units, as they may be damaged if pressed.

Components

Each pair of DSP loudspeakers is supplied with the following components:

- The DSP loudspeakers complete with grilles.
- A hex wrench (3mm) for the drive units.
- Eight screw-in spikes with lock nuts and protectors, together with a wrench for fitting them.
- Head units complete with cups.
- Three knurled screw-in pillars for each head unit to sit on.
- Three plastic spacers per head unit to fit over the pillars.
- A head connection lead per head unit.
- A top glass plate for each base unit.
- MSR+ remote, battery and user guide.
- One power cord per speaker.
- Meridian M5 lead (8m).
- Meridian S5 lead (8m).
- This user guide.

If any of these items is missing please contact your dealer. We suggest that you retain the packaging carefully for maximum protection in transit.

Caution

Meridian Audio has taken every care in the design, assembly, finishing and packing of this product. The high gloss finish on parts of the cabinet is achieved by painting up to five coats of polyester lacquer onto the plywood, each one hand polished.

Due to the product size and high technology cabinet construction, small marks on the lacquer surface may be visible when unpacked. These small marks can usually be removed as described in *Cleaning*, page 62.

It is the nature of all lacquer finishes to shrink over time. This is unavoidable and may result in cabinet joint lines becoming visible.

Meridian Audio has supplied products using lacquer finishes for many years and we are confident that when carefully used your product will return a lifetime's enjoyment.

To fit the feet

The feet ensure that the loudspeakers have a stable base, and can be adjusted to allow for uneven floors. Use the spikes for carpeted floors; they are designed to penetrate the pile without damaging or flattening the carpet. Use the protectors for solid floors.

Each DSP loudspeaker needs four feet, fitted as follows:

- Fit a lock nut to each foot, leaving about 2mm of thread between the lock nut and foot.
- Screw each foot into the threads on the bottom of the base units. Do not fully tighten the lock nut at this stage.
- On solid floors fit the protectors over the spikes.
- When all four feet have been fitted, carefully set the DSP loudspeakers upright in their playing positions and remove the rest of the packaging.
- Adjust the feet until the speakers are stable, and then tighten the lock nuts.

To install the head units

- Locate the three pillars and screw them into the three holes in the top of each base unit.
- Fit the glass plate over the pillars on the top of each base unit.
- Fit a plastic spacer over each pillar.
- Place the head unit on top of each base unit.

On the DSP6000 the gold stripes on the head and base units should line up.

The speakers have the correct orientation if the sloping sides on the heads are to the outside (gold strip inside).

- Connect the end of each head connection lead marked with a red band to the socket in the back of the head unit.

- Connect the other end of each lead to the socket on the back of the base unit.

Tightening the drive units

The DSP loudspeakers typically take about two weeks of normal use for the drive units to settle. It is therefore recommended that you tighten the mounting bolts on each drive unit every few days during this period. Tighten the bolts in symmetrically opposite pairs using the 3mm hex wrench supplied.

You should then check and if necessary retighten the drive units every few years.

To dismantle the loudspeakers

When dismantling the speakers always switch off and disconnect the power first, then disconnect the head unit from the base unit.

Note: Do not disconnect the head lead while the unit is connected to the AC supply and switched on.

It is advisable to remove the head units when moving the speakers. This is achieved by disconnecting the head lead from the base unit and lifting off the head. Take care while the head is not in position as this exposes its mounting spikes. While not in place the head should be stored safely but care should also be taken of the surface they are placed upon as it may be damaged by the cups.

Specifications

Digital inputs and outputs

- 2 x cable inputs, 32–96kHz. FIFO locks at 44.1, 48, 88.2, or 96kHz ± 150 ppm.
- PCM using IEC958, or MHR connection support with auto-detection.
- 1 x 24-bit Multi-bit delta-sigma DACs with 128x oversampling.

Signal processing

- 2 x Motorola 56303 running at 80MHz.
- 4 x 24-bit Multi-bit delta-sigma DACs with 128x oversampling.
- Crossovers linear-phase $\pm 30^\circ$ at 200Hz and 2.6kHz.

Output stages

- Power amplifiers: Complementary bipolar design, with output-stage error correction and twin loop design.
- Bass: 2 x 75W.
- Mid: 75W.
- Treble: 75W.

Acoustic

- 3 way.
- Separate mid/top plywood cabinet.
- Bass drive unit: 4 x 200mm (8") high-efficiency long-throw custom drivers.
- Mid drive unit: 1 x 160mm (6") custom polypropylene driver using phase plug.
- Treble drive unit: 1 x 25mm (1") Meridian piston in short horn, aluminium dome with silver voice-coil.

Characteristics

- Distortion typically $< 0.01\%$, or $< 0.02\%$ up to full power at all frequencies.
- Noise and hum < -94 dB at all volume settings.
- Acoustic output typically > 112 dB spl @ 1m.
- Acoustic noise < 15 dB spl @ 1m.
- Frequency response in room response within 3dB, 25Hz-20kHz, lower at moderate volumes.

Control

- 2 x Meridian Comms.
- 9-pin D connector for RS232 PC control, null modem, 9600 baud, 2N1, no handshake.

Cabinet

- Head enclosure manufactured from interlaminated panels with internal damping and bracing.
- Glass front.
- Head finished in high-gloss black piano lacquer.
- 275mm x 1330mm x 425mm (10.8" x 52.4" x 16.7") (W x H x D).
- 9.5kg (21lb) each.

Power

- 100-125; 200-250V AC 50-60Hz.
- 6VA idle; 200VA max.

Meridian Audio reserves the right to amend product specifications at any time.



DSP7000

This chapter explains how to unpack and install the DSP7000, and gives specifications.

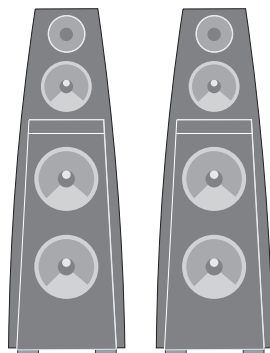

Unpacking

Before you begin installation you should ensure that your DSP loudspeakers are the correct voltage for your local AC supply. If they are not, do not try to install them, and contact your dealer.

You should not make any connections to the DSP loudspeakers, or to any other component in your system, while the AC power supply is connected and switched on.

Unpacking

The unpacking instructions are provided on a separate leaflet enclosed with the speakers. Please refer to this before proceeding.

Care when unpacking

Take great care when unpacking or repacking the DSP loudspeakers that you do not put undue pressure on the face containing the drive units, as they may be damaged if pressed.

Components

Each pair of DSP loudspeakers is supplied with the following components:

- The DSP loudspeakers complete with grilles.
- A hex wrench (3mm) for the drive units.
- Six screw-in spikes with lock nuts and feet together with a wrench for fitting them.
- MSR+ remote, battery and user guide.
- One power cord per speaker.
- Meridian M5 lead (8m).
- Meridian S5 lead (8m).
- This user guide.

If any of these items is missing please contact your dealer. We suggest that you retain the packaging carefully for maximum protection in transit.

Caution

Meridian Audio has taken every care in the design, assembly, finishing and packing of this product. The high gloss finish on parts of the cabinet is achieved by painting up to five coats of polyester lacquer onto the plywood, each one hand polished.

Due to the product size and high technology cabinet construction, small marks on the lacquer surface may be visible when unpacked. These small marks can usually be removed as described in *Cleaning*, page 62.



It is the nature of all lacquer finishes to shrink over time. This is unavoidable and may result in cabinet joint lines becoming visible.

Meridian Audio has supplied products using lacquer finishes for many years and we are confident that when carefully used your product will return a lifetime's enjoyment.

Tightening the drive units

The DSP loudspeakers typically take about two weeks of normal use for the drive units to settle. It is therefore recommended that you tighten the mounting bolts on each drive unit every few days during this period. Tighten the bolts in symmetrically opposite pairs using the 3mm hex wrench supplied.

You should then check and if necessary retighten the drive units every few years.

Removing the grilles

The grille is guided into position on plugs, and held firmly on the speaker with Velcro fasteners. To remove the grille pull it gently, starting from the bottom edge, allowing time for the Velcro to disengage. Then pull it evenly away from the sides until it is free. Replace the grille after tightening the drive units.



Specifications

Digital inputs and outputs

- 2 x cable inputs, 32–96kHz. FIFO locks at 44.1, 48, 88.2, or 96kHz ± 150 ppm.
- PCM using IEC958, or MHR connection support with auto-detection.
- 1 x 24-bit Multi-bit delta-sigma DACs with 128x oversampling.

Signal processing

- 2 x Motorola 56303 running at 80MHz.
- 4 x 24-bit Multi-bit delta-sigma DACs with 128x oversampling.
- Crossover linear-phase $\pm 30^\circ$ at 200Hz and 2.6kHz.

Output stages

- Power amplifiers: Complementary bipolar design, with output-stage error correction and twin loop design.
- Bass: 2 x 75W.
- Mid: 75W.
- Treble: 75W.

Acoustic

- $3\frac{1}{2}$ way.
- Ported bass enclosure.
- Isolated mid enclosure.
- Bass drive unit: 2 x 200mm (8") high-efficiency long-throw custom drivers.
- Mid drive unit: 1 x 160mm (6") custom polypropylene driver using phase plug.
- Treble drive unit: 1 x 25mm (1") Meridian piston in short horn, aluminium dome with silver voice-coil.

Characteristics

- Distortion typically $< 0.01\%$, or $< 0.02\%$ up to full power at all frequencies.
- Noise and hum < -94 dBr at all volume settings.
- Acoustic output typically > 111 dB spl @ 1m.
- Acoustic noise < 15 dB spl @ 1m.
- Frequency response in room response within 3dB, 28Hz-20kHz.

Control

- 2 x Meridian Comms.
- 9-pin D connector for RS232 PC control, null modem, 9600 baud, 2N1, no handshake.

Cabinet

- Entire speaker manufactured from interlaminated panels.
- MDF cloth-covered grille.
- Finished in high-gloss piano lacquer.
- 346mm x 1010mm x 450mm (13.6" x 39.8" x 17.7") (W x H x D).
- 50kg (110lb) each.

Power

- 100-125; 200-250V AC 50-60Hz.
- 20VA standby; 600VA max.

Meridian Audio reserves the right to amend product specifications at any time.

.....

.....

.....



Connecting up the DSP loudspeakers

**This chapter explains how you should connect your DSP loudspeakers
to the other audio equipment in your system.**

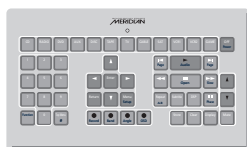

Connecting the loudspeakers

Back panel

The following diagrams give details of the back panel connections:

All speakers except DSP5200/DSP5200HC

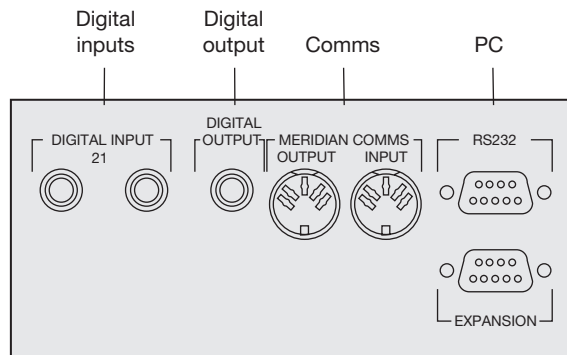

DSP5200/DSP5200HC

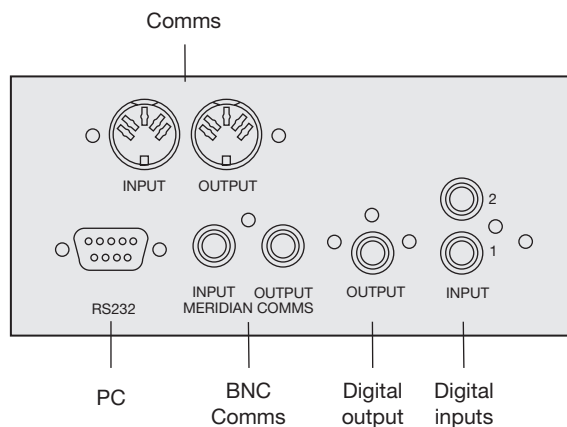

Digital connections

The following table gives details of the digital audio connections:

Use this connection	To connect to this
DIGITAL INPUT 1, DIGITAL INPUT 2	A digital source, such as a digital sound processor, digital preamplifier, CD player, or DVD player
DIGITAL OUTPUT	A second (slave) DSP loudspeaker, using an S5 lead.

The digital connections should be made with high-quality 75Ω screened cable. Suitable cables are available from Meridian. We do not recommend using audio cables, which do not have adequate shielding or the correct impedance, or cables intended for UHF applications, as these do not

provide adequate shielding in the 1–30MHz region.

Communications connections

The following table gives details of the communications connections:

Use this connection	To connect to this
COMMS INPUT	The COMMS connection on a Meridian control unit or preamplifier.
COMMS OUTPUT	The COMMS INPUT on a second DSP loudspeaker.
RS232	The serial port of a PC, to control the DSP loudspeaker using a computer. For more information see the Meridian Web site, http://www.meridian-audio.com .
EXPANSION	For future expansion.

Connecting to other equipment

To connect two DSP loudspeakers to a Meridian CD Player, Control Unit, or other digital source

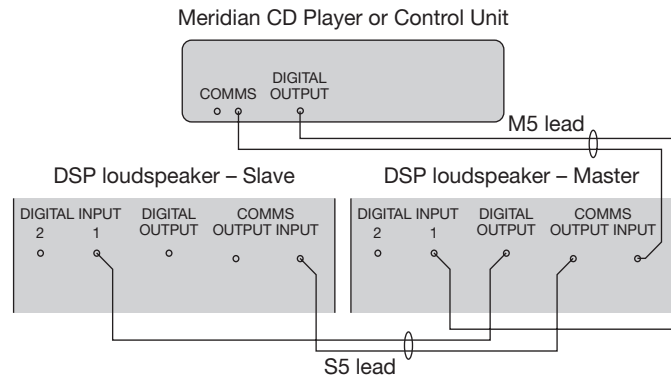

You can create a complete system by connecting a pair of DSP loudspeakers directly to a digital source. The DSP loudspeakers include volume, balance, and tone controls allowing you to control the system using the MSR+.

- Connect the DIGITAL OUTPUT and a COMMS socket from the Meridian source or control unit to DIGITAL INPUT 1 and the COMMS input on the DSP loudspeaker chosen as the master, using the M5 lead supplied.
- Connect the DIGITAL and COMMS outputs from the master DSP loudspeaker to DIGITAL INPUT 1 and the COMMS input on the other (slave) DSP loudspeaker, using the S5 lead supplied.

You can connect another digital source to DIGITAL INPUT 2, and then configure the appropriate source selection key on the remote to select that input: see *Configuring the sources*, page 55.

See the chapter *Using the DSP loudspeakers*, page 45, for information about controlling the DSP loudspeakers.

To connect three or more DSP loudspeakers in a Meridian surround system

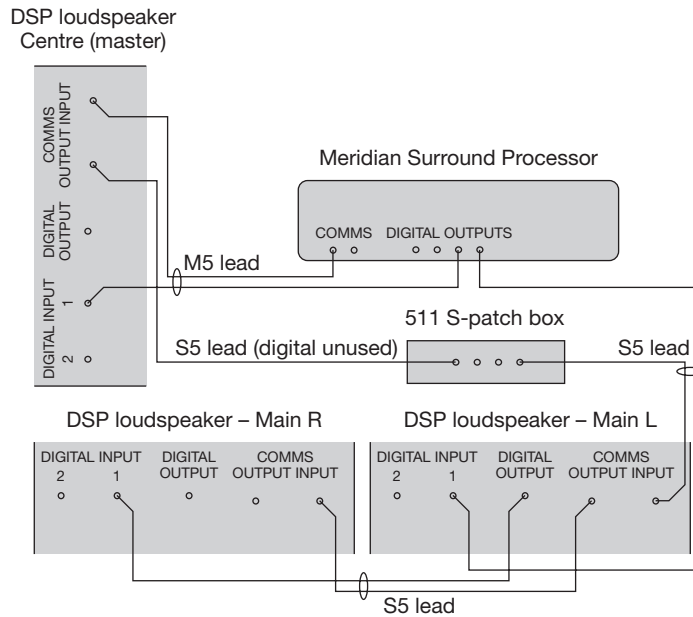

If your system includes more than two Meridian DSP loudspeakers you will need a 511 S-patch box (available separately) to link together the S5 leads from each speaker, as shown above. **Note:** This does not apply to the 861, which includes a built-in patch box.

- Use the comms part of an M5 lead to connect one of the COMMS sockets on the Meridian Surround Processor to the DSP loudspeaker you have chosen as the master (typically the centre speaker).
- Use the audio part of the M5 lead to connect the DSP loudspeaker to the appropriate digital output on the Meridian Surround Processor.
- Connect the COMMS output from the master DSP loudspeaker to one socket on the 511 using an S5 lead.
- Link all the other DSP loudspeakers together in pairs using S5 leads, as shown in the illustration.
- Connect each pair of DSP loudspeakers to the appropriate digital output on the Meridian Surround Processor, using an S5 lead. The other part of the S5 lead is used to distribute the COMMS from the 511 to each pair of DSP loudspeakers.

To use a DSP loudspeaker as a centre speaker

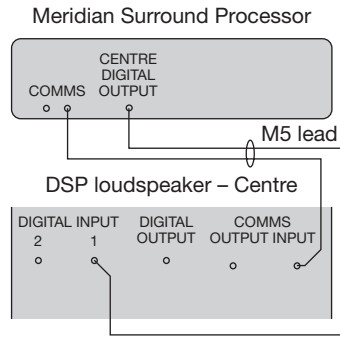

You can use a single DSP loudspeaker as a centre speaker in a Meridian surround system.

- Connect the speaker to the CENTRE digital output using an M5 lead, as shown in the illustration.

Positioning the digital loudspeakers

To obtain the best sound

For best results adjust the position of the loudspeakers while listening to music.

If possible, have the most acoustically absorbent wall in the room behind the front speakers. Ideally have each DSP loudspeaker at least 0.5m (20") from a corner, and position them approximately 0.25m (10") from the wall.

If you are using a DSP loudspeaker as a centre channel, place the speaker centrally between the main left-right pair and, if possible, arrange for the treble units of the three speakers to be approximately the same height.

You can configure the frequency response of the DSP loudspeakers to compensate for a position close to a wall or corner; see *To adjust the frequency response*, page 57.

.....

.....

.....

Using the DSP loudspeakers

In systems with a Meridian preamplifier or control unit all of the functions of the DSP loudspeakers, including volume, treble, and bass, are operated via the controller. For more information refer to the user guide for the preamplifier or control unit, and you can ignore this chapter.

The DSP loudspeakers can also be connected directly to up to two digital sources to create a complete, minimum system. This chapter provides step-by-step instructions for operating the DSP loudspeakers in a system with no Meridian preamplifier or control unit.



Selecting a source

When not playing, the DSP loudspeakers should be left in the standby state. This uses a negligible amount of electricity, but ensures that the components of the loudspeakers operate at maximum efficiency from the moment you start.

If you are not going to use the DSP loudspeakers for several days you should switch each unit completely off at the back panel, and disconnect it from the AC power supply.

To select a source

- Press the appropriate source key on the remote; eg **Radio**.

This will bring the DSP loudspeakers out of standby, and the displays will show the currently selected source and volume setting.

For example:



By default the 12 sources are available.

As standard, all the sources are set to select the D1 digital input. To select the D2 input, see *To configure a source*, page 55.

To switch to standby

- Press **Off** on the remote.

The loudspeakers will switch to standby and the displays will show:



Changing the display

The DSP loudspeakers display information about the current settings on the 8-character front-panel display.

In addition, three coloured indicators show status information.

To change the displayed information

- Press **Display**.

Pressing **Display** steps between the following options:

Display option	Example
Source and volume	Radio 65
Meridian source display (dashes if not present)	— — — —
Audio format	PCM 96k
Blank	

The audio format display shows PCM, Data, or MHR followed by the frequency, or NL (not locked).

Status indicators

The display includes the following status indicators:

Indicator	Description
Red	Master loudspeaker.
Yellow	88kHz or 96kHz input.
Green	Clipping; see <i>Troubleshooting</i> , page 60.

Adjusting the volume

The DSP loudspeakers adjust the volume in precise steps of 1dB, where 9dB is equivalent to doubling the loudness, and can be varied in the range 1 to 99dB.

When you first connect power to the DSP loudspeakers the volume is set to 65, which is similar to the midway position of the rotary volume control on a conventional preamplifier.

To change the volume

- Press the red ▲ or ▼ keys on the remote.

As you adjust the volume setting the display will show the current volume level.

For example:



To mute (silence) the sound

- Press **Mute** on the remote.

The display will show:



To restore the sound

- Press **Mute** again on the remote.

Changing the treble, bass, or phase

The DSP loudspeakers provide sophisticated treble and bass controls, to allow you to adjust the broad balance of the system to correct for the acoustics of your listening room, or for a misbalanced recording.

If you have a Meridian Surround Controller these functions are performed via the surround controller.

The controls are more subtle than conventional tone controls, and take advantage of digital signal processing techniques to provide a more natural adjustment of the frequency response.

You can also change the absolute phase of the signal, to compensate for signals which are out of phase, giving an unnatural-sounding bass.

To change the treble

- Press **Function** ◀ or **Function** ▶ until the display shows the current treble.

For example:



- Press **Function** ▲ or **Function** ▼ to change the treble.

The treble control tilts the frequency of the response over the entire frequency range to make the sound brighter or dimmer. It can be adjusted between ± 10 db in 0.5dB steps. Normally settings between +1.0 and -2.0 will give the most natural results.

To change the bass

- Press **Function** ◀ or **Function** ▶ until the display shows the current bass setting.

For example:



- Press **Function** ▲ or **Function** ▼ to change the bass.

The bass control allows you to adjust the bass response in the room by ± 5 dB in 0.5dB steps. Normally settings between +3.0 and -2.0 will give the most natural results.

To change the absolute phase

- Press **Function** ▶ or **Function** ◀ until the display shows the current phase.

For example:



- Press **Function** ▲ or **Function** ▼ to change the phase.

*If you have a
Meridian Surround Controller
these functions are performed
via the surround controller.*

Changing the listening position

The balance control of the DSP loudspeakers uses digital signal processing to compensate for an off-centre listening position by delaying and diminishing the sound in one speaker, thus effectively shifting the speaker's image back.

The axis control allows you to adjust the optimum listening height of the DSP loudspeakers, like a balance control operating in the vertical plane.

To change the balance

- Press **Function** ◀ or **Function** ▶ on the remote until the display shows the current balance.

For example:



- Press **Function** ▲ or **Function** ▼ to change the balance.

The display shows the direction and position of the listening position.

For example:



There are 32 steps in each direction.

To change the axis

- Press **Function** ◀ or **Function** ▶ on the remote until the display shows the current axis setting.

For example:



- Press **Function** ▲ or **Function** ▼ to change the axis.

The axis can be adjusted between 3 and -2, where 0 corresponds to the axis of the treble unit. Usually a listener will be below that position, so we recommend settings of -1 or -2.

Configuring the DSP loudspeakers

This chapter explains how to configure the DSP loudspeakers to suit the other equipment in your system.

The first stage in configuring the DSP loudspeakers is to choose one of the standard settings, and these are designed to set all of the parameters to their most common values. You can also configure each setting individually for applications not catered for by one of the standard settings.

Once you have configured the DSP loudspeakers you will probably never need to change the configuration, unless you alter the equipment connected to your system at a later stage.

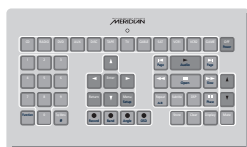

Choosing standard settings

The DSP loudspeakers provide the following five alternative standard settings, called Types, which configure all aspects of the DSP loudspeakers into the most commonly needed configurations:

Type	Description
1	Selects D1 for all sources. For use with a stereo system; eg a CD or DVD player such as the G08 or G91.
5	For use with a CD player connected to D1; all other sources use D2.
6	For use with a Meridian Surround Controller.
7	For use in a second room.
8	For use in the second or third room of a three-room system.

Types 2, 3, and 4 are for compatibility with 200/600 series units.

In all cases except Type 5, the D1 input is used for all sources.

Choosing one of the standard settings overrides any other configuration you may have performed, and so can be used to reset the configuration of the speakers.

To select a standard setting

- Switch off the DSP loudspeaker.
- Turn on the power again while holding down the key on the remote corresponding to the Type you want to use.

The display will show the Type number.

For example:



- Release the remote key.

The display will show:



You should now specify the speaker's position as follows.



To specify the speaker position

- Press ▲ or ▼ to specify the speaker position.

The options are shown in the following table:

Display	Position
L.	Left.
R.	Right.
C.	Centre (Type 6 only).
S.L.	Left surround (Type 6 only).
S.R.	Right surround (Type 6 only).

To choose master or slave

You should select one loudspeaker to be the master; this will normally be the centre channel. For more information see the chapter *Connecting up the DSP loudspeakers*, page 37.

Each other DSP loudspeaker should be configured as a slave as follows.

- Press the green ► (Play) key on the remote.

The display shows, for example:



Alternatively you can configure the speaker as a slave, with the D2 input used for all sources, as follows:

- Press the green ► (Play) key on the remote repeatedly until the display shows:



When you have configured the loudspeaker:

- Switch off the DSP loudspeaker, using the power switch on the back, and then switch on again to restore normal operation.



Specifying information about your system

You can configure the operation of the DSP loudspeakers to suit the way your system is set up, and the way in which you want to use it. These settings are configured automatically to appropriate values when you choose one of the standard Type settings, and you should not normally need to alter them; see *Choosing standard settings*, page 52.

To configure the DSP loudspeaker

- Turn off the DSP loudspeaker, using the power switch on the back panel.
- Turn on the power again while holding down the **0** key on the remote.

The display will show the current setting of the first configuration option.

For example:



- Press **▶** or **◀** to step between the options.
- Press **▲** or **▼** to change the value of the current option.

The table below shows the options you can configure:

Option	Initial value in Type 1
Position and master/slave	L.
Compatibility (G, 500, 200 Pre, or 200 CD)*	G
Controller mode (Auto, Con, or NCon)	Auto
System address (1–8)	S.A. 1
Product address (1–8)	P.A. 1
Volume mode (1=normal, 2/3=second/additional room)	L.E. 1
Balance control? (N or Y)	Bal. Y
Centre menus? (N or Y)	Centre N
Diagnostic displays? (N or Y)	Diag. N

* G gives 500 Comms and MSR+ sources, 500 gives 500 Comms and MSR sources, and 200 Pre or 200 CD are legacy modes.

Configuring the sources

When the master DSP loudspeaker is set to one of the standard Types the 12 source selection keys on the remote select inputs D1 and D2 as shown in the table on page 52.

If the configuration you want is not catered for by one of the standard settings, you can configure each source individually.

The DSP loudspeakers provide 12 sources corresponding to the 12 source selection keys on the remote:

CD, RADIO, DVD, AUX, DISC, TAPE, TV, CABLE, SAT, VCR1, VCR2, and GAME.

For each source you can configure:

- The label used for it on the front panel display, from a range of alternative labels.
- The digital input it selects.
- The comms type and address, to control other Meridian 500 Series equipment.
- Other advanced options.

You only need to configure the sources on the DSP loudspeaker you have specified as the master.

To configure a source

While in configuration mode:

- Press the source key on the remote corresponding to the source you want to configure.

For example, to configure the Radio source the display initially shows:



- Press ► or ◀ to step between options.

The right-hand set of characters shows the current value of the option.

- Press ▲ or ▼ to change the value of the option.

When you have finished programming sources:

- Switch off at the back panel, and then switch on again to restore normal operation.

The options are summarised in the table below:

Option	Initial value	Alternatives	Explanation
Label	Radio	CD, Radio, LP, etc.	The label used to identify the source on the front panel display.
Audio input	D1	D1 or D2.	Choose D1 or D2 to specify the input.
Comms type	2C	1C – 9C, or NC.	Choose 1C for a Meridian CD player, 2C for a Meridian FM Tuner, 3C for a Meridian DVD player, or NC otherwise.
Address	1A	1A – 8A.	Allows you to have up to eight of type.
FIFO	FF, Y	Y or N.	Choose N to disable the FIFO buffer if you have difficulty locking to a poor source.

Configuring the setup options

When configuring the DSP loudspeakers, point the remote at the speakers, even if you have a Meridian Surround Controller.

The setup options allow you to adjust the frequency response of the loudspeakers to compensate for their position. You only need to configure the master loudspeaker.

To select Setup mode

- Turn off the DSP loudspeaker using the power switch on the back panel.
- Turn on the power again while holding down the **Store** key on the remote.

The display will show:



It will then revert to standby:



You can now operate the speaker in the usual way, using the additional setup menus to adjust the response while listening to sources.

When you have finished adjusting the setup options:

- Switch off at the back panel, and then switch on again to restore normal operation with the setup you have programmed.

To adjust the frequency response

- Press **Function** ► or **Function** ◀ until the display shows the current response setting.

For example:



- Press **Function** ▲ or **Function** ▼ to select the appropriate option as follows:

Option



What it means

Flat frequency response.

Speaker closer than 0.5m (20") to a wall.

Applies a second-order high-pass filter at 80Hz for use with an analogue subwoofer.

Applies a second-order high-pass filter at 120Hz for use with an analogue subwoofer

Speaker closer than 0.5m (20") to a corner.

To adjust the centre frequency response and tilt offset

If your system includes a DSP centre speaker you should set **Centre Y** on the master speaker. An additional frequency response option is then provided to allow you to adjust the centre speaker, with the options:

C.Fre, **C.bou**, **C.Sb1**, **C.Sb2**, and **C.Cor**.

- Press **Function** ► or **Function** ◀ until the display shows the current centre frequency response.

For example:



- Press **Function** ▲ or **Function** ▼ to select the appropriate option for the centre speaker.

An additional centre tilt offset option is also provided. The centre tilt offset is added to the treble value for the selected source. The recommended setting is -1dB when the speaker is positioned above a television.

- Press **Function** ► or **Function** ◀ until the display shows the current centre tilt offset.

For example:



- Press **Function** ▲ or **Function** ▼ to adjust the centre tilt offset.

To store the settings

Once you have adjusted the frequency response for the speakers in your system you should store the settings using the following procedure:

- Press **Function Store**.

The display shows:



- Turn off the DSP loudspeaker using the power switch on the back panel.

When you turn on the power again the speaker will operate normally with the frequency response settings you have stored.

.....

Troubleshooting

.....

This chapter provides suggested solutions to typical problems that may occur when setting up the DSP loudspeakers.

If you are still not able to resolve a difficulty with the help of this guide and the suggestions in the following pages, please contact your Meridian dealer or Meridian Audio Ltd.



Troubleshooting

Display on front panel not lit

Check the following:

- There is AC power connected to the socket on the back of the DSP loudspeaker.
- The power switch on the back panel of the DSP loudspeaker is turned on.

If the display will still not illuminate, check any fuses in your power supply and the fuse in the inlet of the DSP loudspeaker. If these are all intact, contact your dealer.

Remote not working

Check the following:

- The battery in the MSR+ remote.
- See if the DSP loudspeaker has been set up as not controller in the Meridian Configuration program; see *Configuring the setup options*, page 57. **Note:** This may be deliberate by your dealer.

Unit goes silent when played hard and displays 'Hot'

The DSP loudspeakers have a temperature sensing system on board, which prevents overheating of the electronics. The sound will continue when the speaker has cooled.

There is radio interference

The DSP loudspeaker is a digital audio and computing device which has been designed to very high standards of electromagnetic compatibility.

If this equipment does cause or suffer from interference to/from radio or television reception then the following measures should be tried:

- Reorient the receiving aerial (or antenna) or route the antenna cable of the receiver as far as possible from the DSP loudspeaker and its cabling.
- Ensure that the receiver uses well-screened antenna cable.
- Relocate the receiver with respect to the DSP loudspeaker.
- Connect the receiver and this product to different AC outlets.
- If the problem persists contact your dealer.

Drive units move when the speaker is switched on or off

This is normal as the speaker active electronics settle.

Configuring the DSP loudspeaker does not have any effect

Make sure that you are configuring the DSP loudspeaker used as the master digital loudspeaker in the system. This determines the configuration of all digital loudspeakers in the system.

Unit stays in standby

- Check that it is connected correctly.
- Turn the system on from another Meridian product in the system.

Only the master loudspeaker plays

- Check the S5 cables are connected correctly.

Sound is odd or mono

- Check that the DSP loudspeakers are correctly configured as Left and Right respectively.

The green indicator flashes or stays on

This indicates that DSP clipping is occurring.

Brief flashes indicate occasional clipping which will not be audible.

If the indicator stays on for long periods this may indicate a fault in the configuration of your system, and you should contact your Meridian dealer.

Cleaning

Cleaning (DSP5200, DSP5200HC, DSP6000, DSP6000C, and DSP7000 only)

On black speakers, small marks on the lacquer surface can usually be removed by treating with Black Turtle Wax Color Magic.

Do not use any coarse polish such as Auto Colour restorer, and always test any polish on a non-visible area first. Do not use any polish containing a solvent; these can cause crazing of the surface.

Deeper scratches can be removed by treating with additional polyester lacquer filler and then polishing carefully. Consult your authorised Meridian dealer for advice before attempting any repair.

Service and guarantee

Service

The Meridian components have been carefully designed to give years of untroubled service. There are no user-serviceable parts inside the case, nor do the units require any form of maintenance.

In the unlikely event that your DSP loudspeaker fails to function correctly, it should be returned, in its original packaging, to your Meridian dealer.

In case of difficulty within the UK or USA please contact the appropriate sales and service address shown on page v.

In case of difficulty outside the UK or USA, contact the importing agent for the territory. A list of Meridian agents abroad is available from Meridian Audio.

No responsibility can be accepted for the DSP loudspeakers whilst in transit to the factory or an agent, and customers are therefore advised to insure the unit. When seeking service under guarantee, proof of the date of purchase will be required.

Guarantee

Each DSP Digital Loudspeaker System is guaranteed against defects in material and workmanship for two years from the date of purchase.

The guarantee is void if the DSP Digital Loudspeaker System has been subject to misuse, accident, or negligence, or has been tampered with or modified in any way without the written authorisation of Meridian Audio Limited. **Note:** Connecting anything other than the correct network lead to the COMMS sockets may cause damage to the DSP Digital Loudspeaker System which will not be covered by this guarantee. Attempted servicing by unauthorised people may also invalidate this guarantee. Labour and carriage charges are not covered unless by local agreement.

Outside the UK, local warranty liability is restricted to equipment purchased within the territory. Our agents abroad are only under contractual obligation to service under guarantee equipment sold through them. They are entitled to make a non-refundable charge for any service carried out on other equipment.

This guarantee does not limit your statutory rights within the United Kingdom.

.....

.....

.....

Index

A

absolute phase, changing	49
accessories	6
axis, changing	50

B

back panel	38
balance, changing	50
bass, changing	49

C

cabinet	3
centre frequency response, configuring	58
centre speaker, connecting	42
centre tilt offset, configuring	58
cleaning	62
COMMS INPUT	39
COMMS OUTPUT	39
communications connections	39
configuration options	54
configuring setup options	57
configuring sources	55
connecting the loudspeakers	38
connecting to other equipment	40
connections	
communications	39
digital inputs	38
digital output	38

D

digital inputs	38
digital output	38
dismantling the loudspeakers	28
display, changing	47
DSP5000 and DSP5000C	7
DSP5200 and DSP5200HC	13
DSP5500, DSP5500HC, and DSP5500C	19
DSP6000 and DSP6000C	25
DSP7000	31

F

frequency response, configuring	57
--	-----------

G

guarantee	63
------------------	-----------

H

head units, installing	27
-------------------------------	-----------

L

lacquer finish	14, 26, 32
polishing	62
listening position, changing	50

M

master, selecting	53
Meridian comms	4
Meridian Digital Music System	5
Meridian Digital Theatre™	5
Meridian High Resolution (MHR)	4
mounting options	3
muting the sound	48

P

phase, changing	49
positioning the loudspeakers	43
power amplifiers	3

R

remote, troubleshooting	60
--------------------------------	-----------

S

safety warnings	ii
sample configurations	
Meridian Digital Music System	5
Meridian Digital Theatre™	5
selecting a source	46
service	63
settings, storing	58
setup options, configuring	57
sources	
configuring	55
selecting	46

speaker positioning	43
specification	
DSP5000 and DSP5000C	10
DSP5200 and DSP5200HC	17
DSP5500, DSP5500HC, and DSP5500C	22
DSP6000 and DSP6000C	29
DSP7000	34
standard settings, selecting	52
standby, switching to	46
status indicators	47
storing settings	58
switching to standby	46

T

tightening the drive units	9, 15, 21, 28, 33
-----------------------------------	--------------------------

tilt offset, configuring	58
treble, changing	49
troubleshooting	59

U

unpacking	
DSP5000 AND DSP5000C	8
DSP5200 and DSP5200HC	14
DSP5500, DSP5500HC, and DSP5500C	20
DSP6000 AND DSP6000C	26
DSP7000	32

V

volume	
adjusting	48
muting	48