



**Robert Bosch GmbH**  
Power Tools Division  
70745 Leinfelden-Echterdingen  
Germany

[www.bosch-pt.com](http://www.bosch-pt.com)

1 609 929 U17 (2010.04) PS / 172 UNI



1 609 929 U17

## GTA 3800 Professional



- |  |  |                                       |
|--|--|---------------------------------------|
| <b>de</b> Originalbetriebsanleitung          | <b>el</b> Πρωτότυπο οδηγιών χρήσης                 | <b>sr</b> Originalno uputstvo za rad  |
| <b>en</b> Original instructions              | <b>tr</b> Orijinal işletme talimatı                | <b>sl</b> Izvirna navodila            |
| <b>fr</b> Notice originale                   | <b>pl</b> Instrukcja oryginalna                    | <b>hr</b> Originalne upute za rad     |
| <b>es</b> Manual original                    | <b>cs</b> Původní návod k používání                | <b>et</b> Algupärane kasutusjuhend    |
| <b>pt</b> Manual original                    | <b>sk</b> Pôvodný návod na použitie                | <b>lv</b> Instrukcijas oriģinālvalodā |
| <b>it</b> Istruzioni originali               | <b>hu</b> Eredeti használati utasítás              | <b>lt</b> Originali instrukcija       |
| <b>nl</b> Oorspronkelijke gebruiksaanwijzing | <b>ru</b> Оригинальное руководство по эксплуатации | <b>ar</b> تعليمات التشغيل الأصلية     |
| <b>da</b> Original brugsanvisning            | <b>uk</b> Оригінальна інструкція з експлуатації    | <b>fa</b> راهنمای طرز کار اصلی        |
| <b>sv</b> Bruksanvisning i original          | <b>ro</b> Instrucțiuni originale                   |                                       |
| <b>no</b> Original driftsinstruks            | <b>bg</b> Оригинална инструкция                    |                                       |
| <b>fi</b> Alkuperäiset ohjeet                |  |                                       |



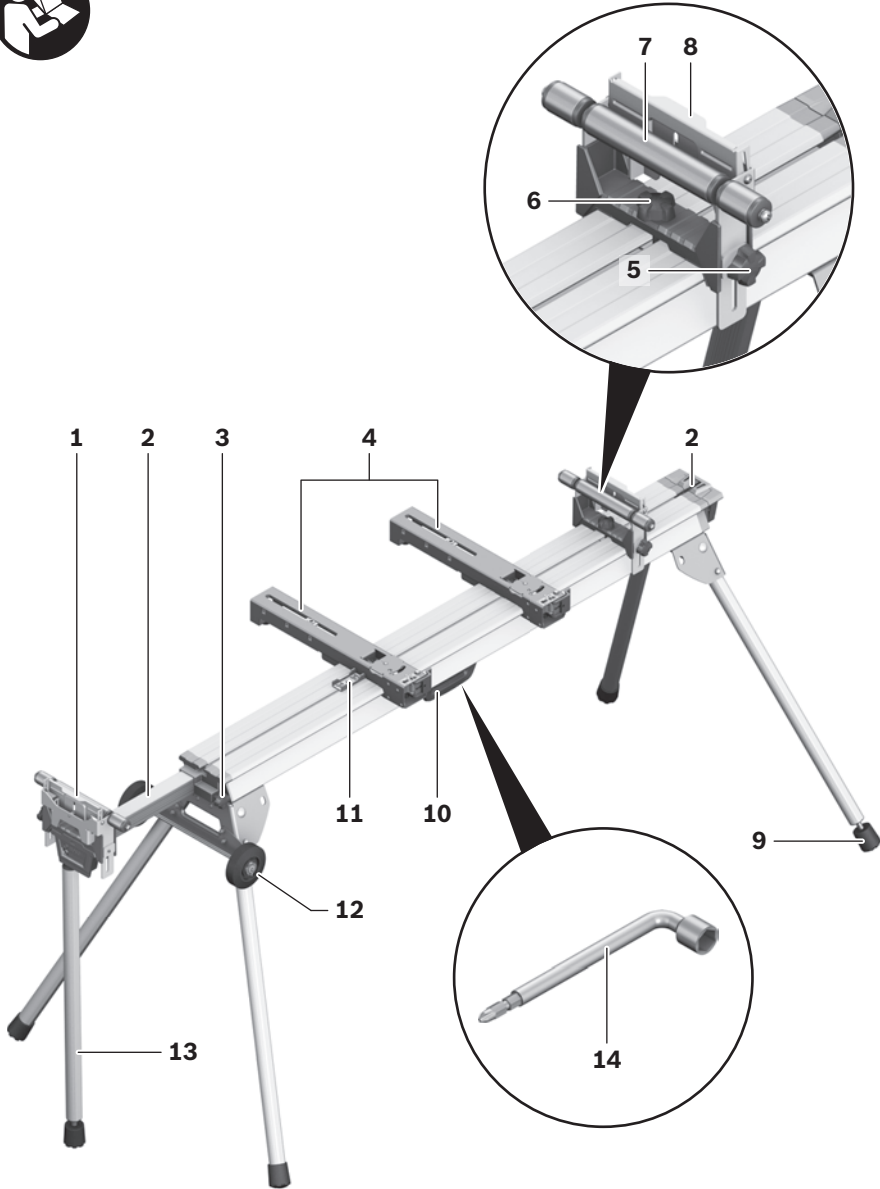

**GTA 3800 Professional**

4 |



**A1**

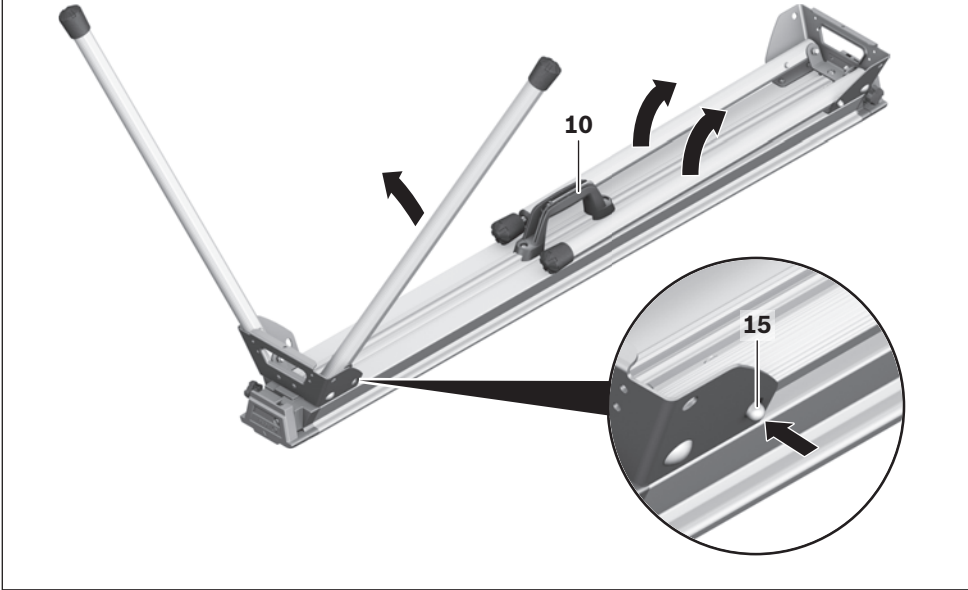

**A2**

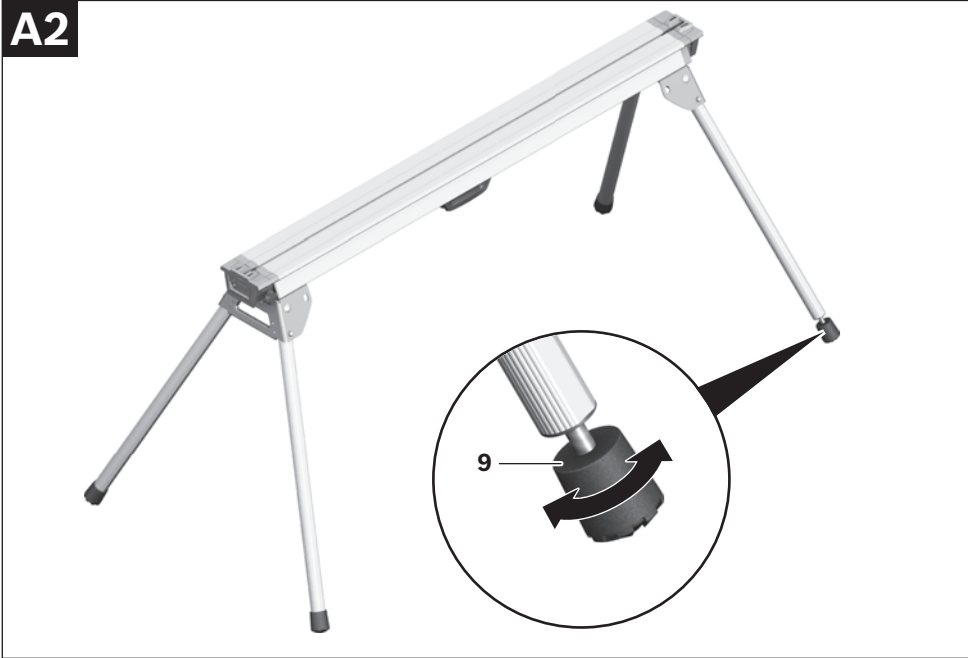

6 |

**B1**

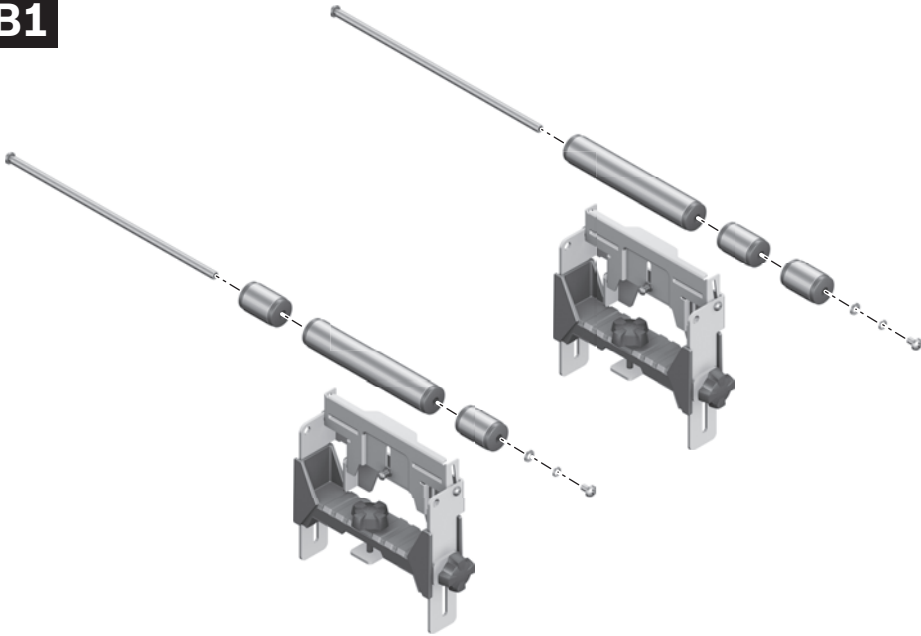

**B2**

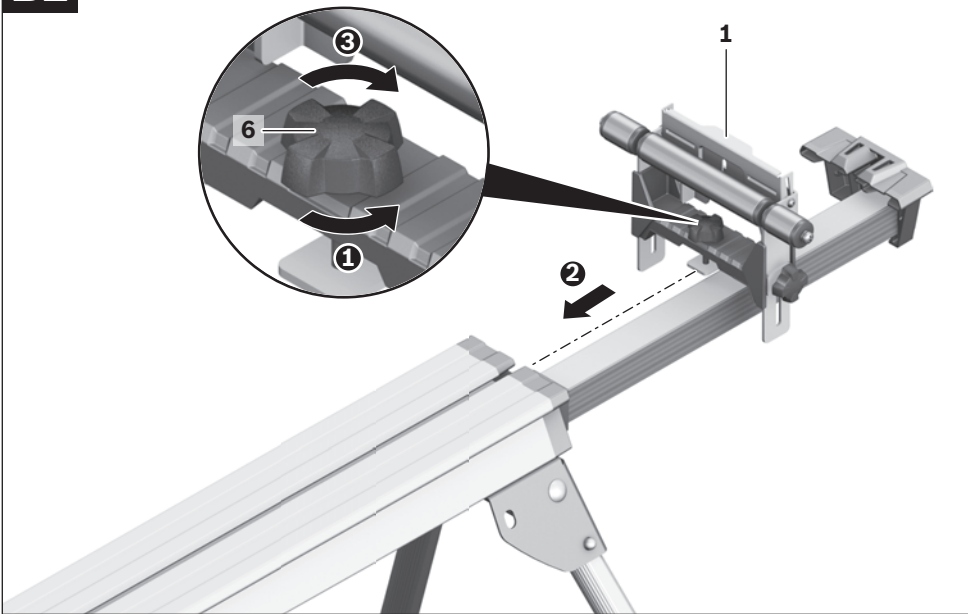

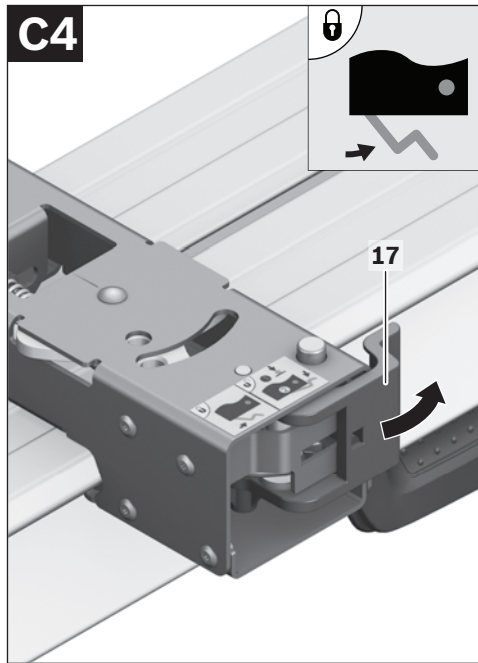
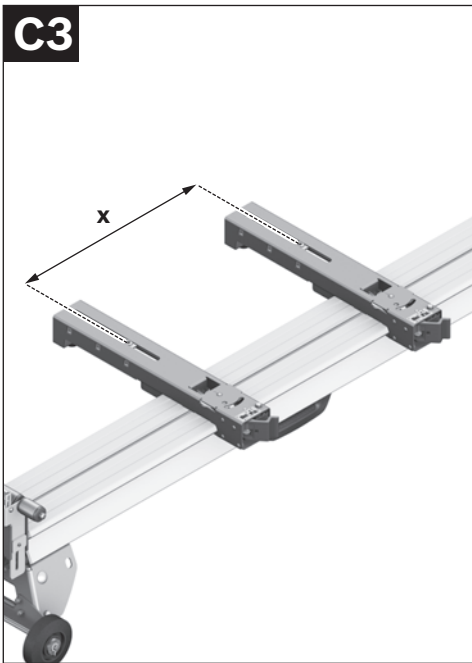
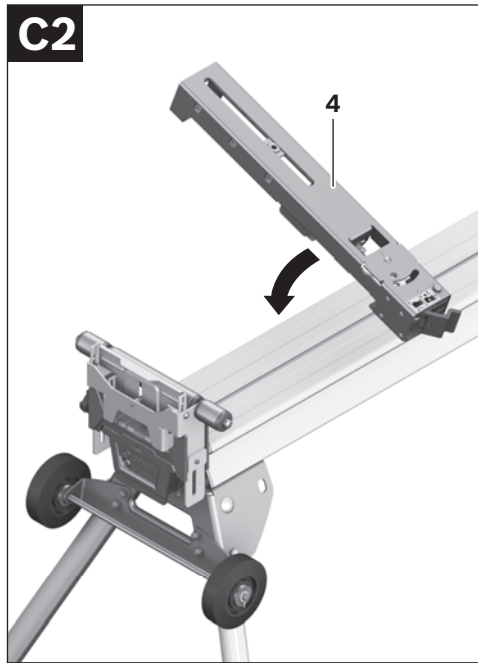
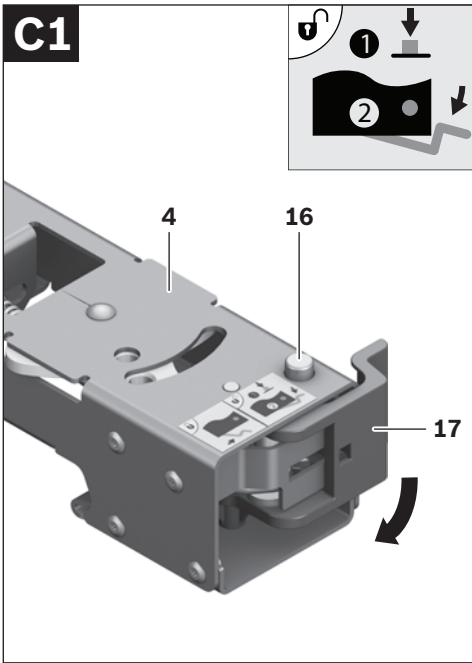

8 |

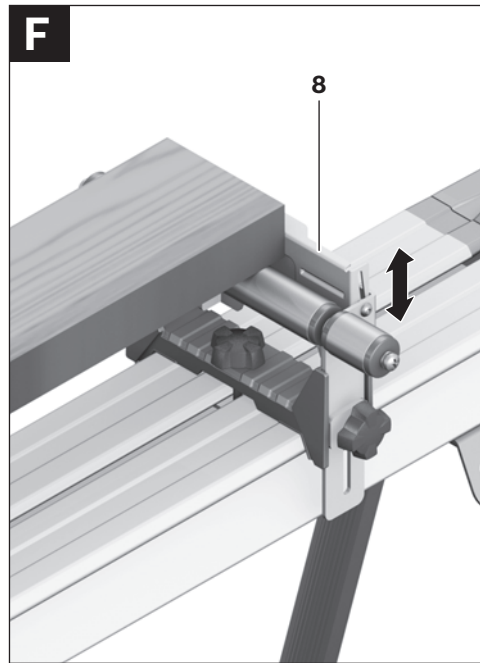
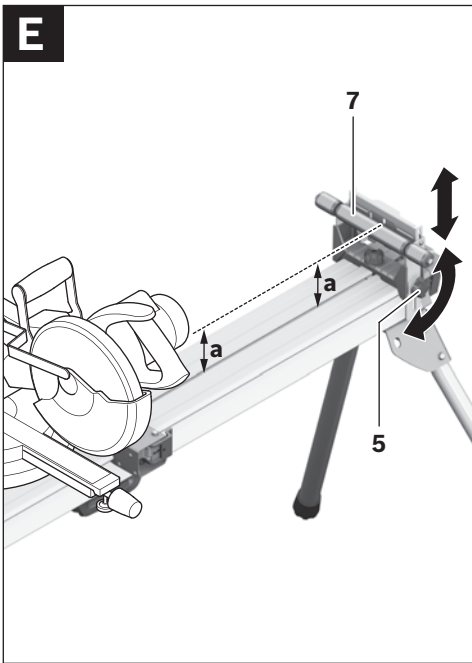
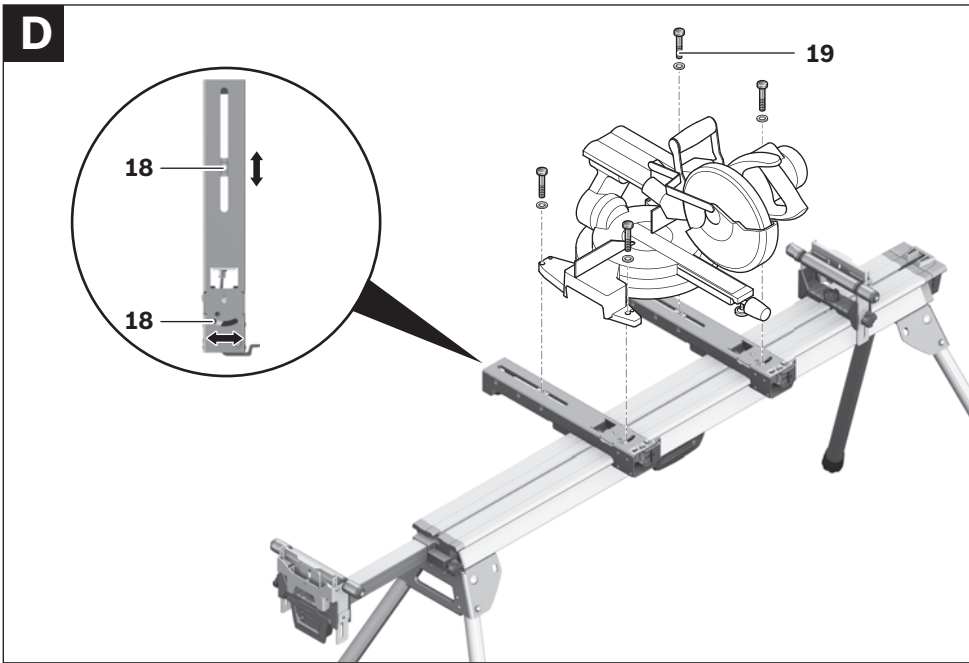

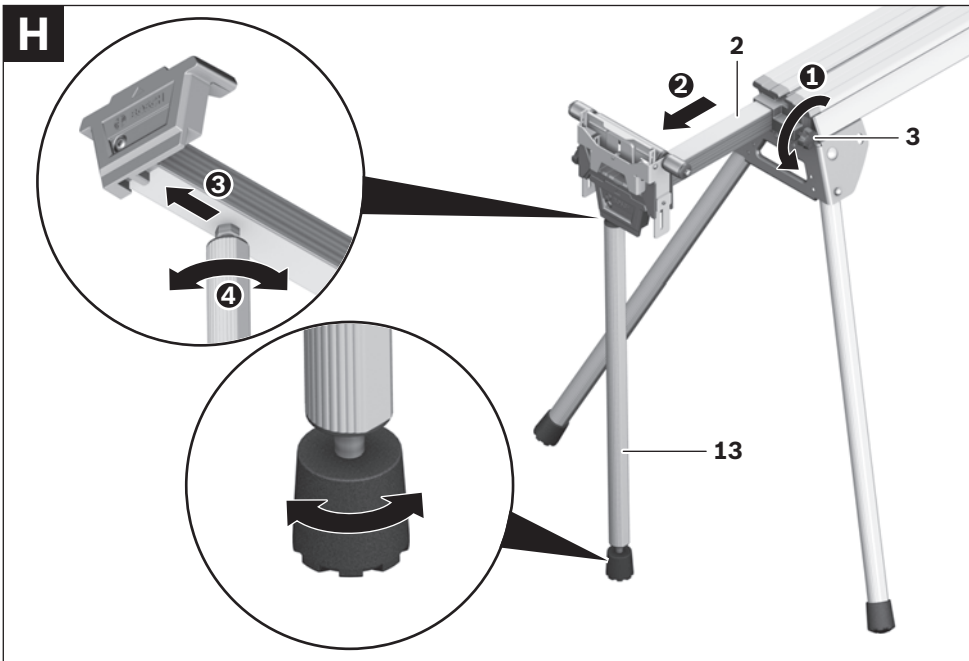
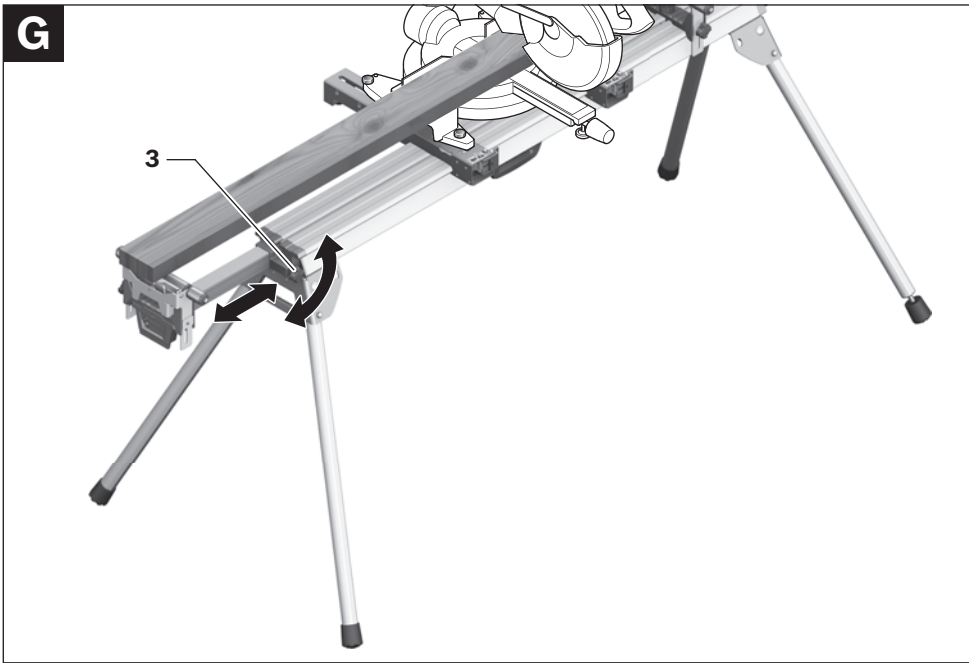



10 |

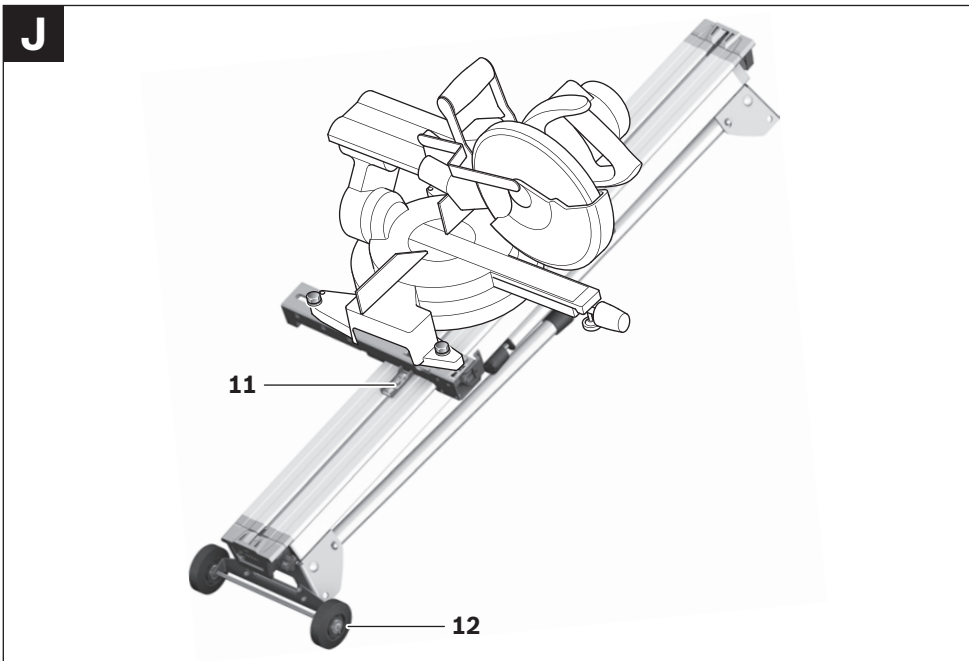
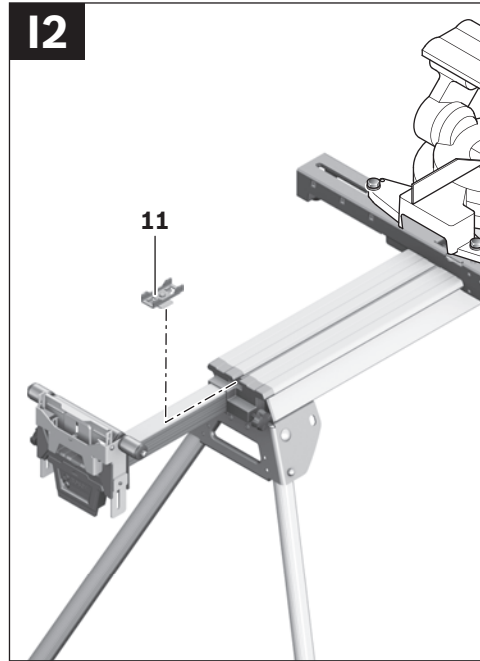
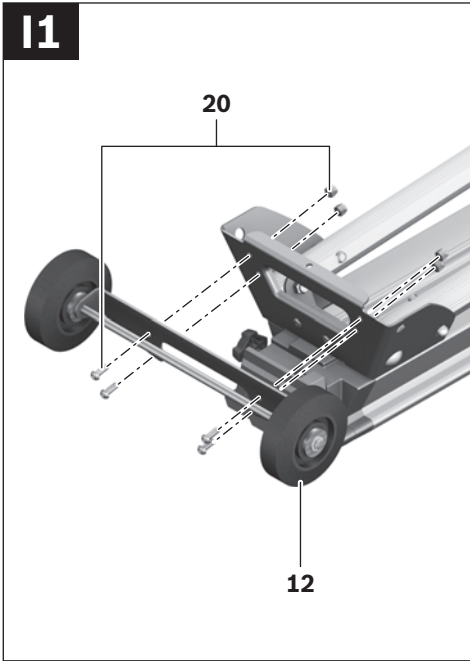

## Safety Notes

### General Safety Rules



**Read all warning notes and instructions enclosed with the saw stand and the power tool to be mounted.**

Failure to follow the warnings and instructions may result in electric shock, fire and/or serious injury.

### Safety Warnings for Saw Stands

- ▶ **Pull the plug from the mains receptacle and/or remove the battery from the power tool before making adjustments on the tool or changing tool accessories.** Unintentional switching on of the power tool is the cause of many accidents.
- ▶ **Assemble the saw stand in the proper manner before mounting the power tool.** Proper assembly is important to prevent the risk of a collapse of the saw stand.
- ▶ **Attach the power tool securely to the saw stand before using it.** Slipping off of the power tool on the saw stand can lead to loss of control.
- ▶ **Place the saw stand on a firm, level and horizontal surface.** If the saw stand can slip off or wobbles, the power tool or the workpiece cannot be uniformly and securely guided.
- ▶ **Do not overload the saw stand and do not use it as a ladder or scaffolding.** Overloading or standing on the saw stand can lead to the upward shifting of the centre of gravity of the stand and its tipping over.
- ▶ **When working or transporting, take care that all bolts and connecting elements are firmly tightened. The attachment sets for the power tool must always be firmly locked.** Loose connections can lead to instability and inexact sawing.

- ▶ **Mount and dismount the power tool only when it is in the transport position (for instructions on the transport position, also see the operating instructions of the respective power tool).** Otherwise, the power tool can have such an unfavourable centre of gravity that it cannot be held securely.
- ▶ **When the power tool is mounted to the attachment set, operate it exclusively on the saw stand.** Without the saw stand, the attachment set with the power tool does not stand securely and can tip over.
- ▶ **Ensure that long and heavy workpieces do not affect the equilibrium of the saw stand.** Long and/or heavy workpieces must be supported at the free end.
- ▶ **Keep your fingers clear of the hinge points while pushing the saw stand together or pulling it apart.** Danger of fingers being crushed or contused.

## Symbols

The following symbols can be important for the operation of your saw stand. Please memorise the symbols and their meanings. The correct interpretation of the symbols helps you operate the saw stand better and more secure.

Symbol	Meaning
	The maximum carrying capacity (power tool + workpiece) of the saw stand is 250 kg.



## Functional Description

### Intended Use

The saw stand is intended to accommodate the following stationary saws from Bosch (as of 2010.03):

– GCM 8 S	3 601 L16 0..
– GCM 800 S	3 601 L16 1..
– GCM 10	0 601 B20 0..
– GCM 10 J	3 601 M20 2..
– GCM 10 M	
– GCM 10 S	0 601 B20 5..
– GCM 10 SD	0 601 B22 5..
– GCM 12	0 601 B21 0..
– GCM 12 SD	0 601 B23 5..
– GTM 12	3 601 M15 0..

Selected chop and mitre saws from other manufacturers can also be mounted.

Together with the power tool, the saw stand is intended for the cutting to length of boards and profiles.

### Product Features

The numbering of the product features refers to the illustration of the saw stand on the graphics pages.

- 1** Workpiece support
- 2** Table extension
- 3** Locking knob of the table extension **2**
- 4** Attachment set
- 5** Locking knob for height adjustment of the roller stand **7**
- 6** Locking knob of the workpiece support **1**
- 7** Roller stand
- 8** Length stop
- 9** Height-adjustable leg
- 10** Carrying handle
- 11** Transport stop\*
- 12** Transport wheels\*
- 13** Height-adjustable support leg of the table extension **2**\*

- 14** Socket spanner (13 mm)/  
Allen key (4 mm)/Phillips screwdriver
- 15** Locking pin
- 16** Button for releasing lever **17**
- 17** Lever for locking the attachment set
- 18** Movable nut
- 19** Fastening kit, power tool
- 20** Fastening kit for transport wheels\*

\*Accessories shown or described are not part of the standard delivery scope of the product. A complete overview of accessories can be found in our accessories program.

### Technical Data

Saw stand	GTA 3800 Professional	
Article number		3 601 M24 000
Length of saw stand without table extension	mm	1578
Length of saw stand with table extension	mm	3877
Height of saw stand	mm	824
Max. carrying capacity (power tool + work- piece) without table extension – Attachment set	kg	250
Max. carrying capacity (power tool + work- piece) with table extension – Attachment set	kg	150
– Per table extension	kg	50
Weight, approx.	kg	22

## Assembly

### Delivery Scope



Please also observe the representation of the delivery scope at the beginning of the operating instructions.

Before assembling the saw stand, check if all parts listed below are provided:

No.	Designation	Quantity
	Saw stand GTA 3800	1
<b>4</b>	Attachment set	2
<b>1</b>	Workpiece support	2
<b>7</b>	Roller stand	2
<b>14</b>	Socket spanner/Allen key/ Phillips screwdriver	1
<b>19</b>	Power tool fastening kit consisting of:	
	– Hexagon bolt (M8 x 45)	4
	– Washer	4

### Additionally required tools (not in delivery scope):

- Open-end spanner (10 mm)

### Assembling the Saw Stand

- Carefully remove all parts included in the delivery from their packaging.
- Remove all packaging material.

### Setting Up the Saw Stand (see figures A1 – A2)

- Lay the saw stand upside down on the floor (legs facing upward).
- Push the locking pin **15** in and tilt the leg upward until the locking pin can be heard to engage.
- Repeat this workstep with the other three legs.
- Turn around the saw stand to the working position.
- Ensure that the saw stand is stable and that all locking pins have engaged.

The saw stand is easily aligned with the height-adjustable leg **9**.

- Screw the leg in or out until the saw stand is aligned level and all four legs face against the floor.

### Mounting the Roller Stand (see figure B1)

- Unscrew the Phillips screw of the roller stand **7** with the Phillips screwdriver **14** provided.

If required, counter-hold the lock nut on the other side of the roller stand using a spanner (size 10 mm).

- Disassemble the roller stand **7**.

There are different possibilities to arrange the individual rollers to the workpiece support with the internally-threaded rod (see figure).

- Arrange the individual parts as required and slide the internally-threaded rod through the rollers and the workpiece support **1**.
- Screw all parts together again.

### Mounting the Workpiece Support (see figure B2)

- Loosen the locking knobs **3** and pull the table extensions **2** via both sides of the saw stand lightly outward.
- Slide the workpiece supports **1** from the left and right each into the upper groove of the saw stand or the table extension. The length stops **8** must face outward.
- Tighten the locking knob **6** to lock the workpiece support.

### Preparing the Saw Stand

#### Preparing the Attachment Sets (see figures C1 – C4)

- To release the attachment sets **4**, press buttons **16** each and open the levers **17**.
- Measure the distance **x** between the mounting holes and your power tool.
- Position the attachment sets **4** centred on the saw stand and at the matching clearance **x** to each other.
- Lock the levers **17** again. The attachment sets are now firmly positioned on the saw stand.

### Fastening the Power Tool to the Attachment Sets (see figure D)

- Position the power tool in the transport position.  
Notes on the transport position are given in the operating instructions of the respective power tool.
- Position the movable nuts **18** in the attachment sets so that they match the mounting holes of the power tool.
- Screw the attachment set and the power tool with the hexagon bolts and the washers from the fastening kit **19** using the provided socket spanner **14**.

## Operation

### Working Advice

Do not overload the saw stand. Always observe the maximum carrying capacity of the saw stand and the two table extensions.

Always hold the workpiece firmly, especially the longer and more heavy section. After cutting through the workpiece, the centre of gravity may become dislocated in such an unfavourable manner that the saw stand tips over.

### Preparing the Workpiece Support

Long workpieces must be underlaid or supported at their free end.

### Adjusting the Height of the Workpiece Support (see figure E)

- Place your workpiece onto the saw table of the power tool.
- Loosen locking knob **5** and adjust the height of the roller stand **7** so that the workpiece rests level.
- Retighten the locking knobs again.

### Sawing Workpieces of the Same Length (see figure F)

The length stop **8** can be used for easily sawing workpieces to the same length.

- Pull the length stop **8** upward until it engages.
- Position the workpiece support **1** at the desired clearance to the saw blade of the power tool.
- To slide in the length stop **8**, tilt it inward and push it all the way down.

### Extending the Saw Stand (see figure G)

The saw stand can be extended on both sides.

To stabilise the saw stand when working long and heavy workpieces, the table extension **2** can be supported with a support leg **13**.

(see “Support Leg for Supporting the Table Extension”, page 20)

- Place your long workpiece onto the saw table of the power tool.
- Release the respective locking knob **3** as required, and pull the table extension **2** out to the desired position.
- Retighten the locking knobs again.

### Fitting the Accessories

#### Support Leg for Supporting the Table Extension (see figure H)

To stabilise the saw stand when working long and heavy workpieces, the table extension **2** can be supported with a support leg **13**.

The support leg **13** can be fastened either to the left or right of the saw stand.

- Loosen locking knob **3** and pull the table extension **2** to be supported somewhat outward.
- Slide the screw head of the support leg **13** into the bottom groove of the table extension **2**.
- Tighten the support leg **13**.
- Screw the height adjustment of the support leg **13** in or out until the saw table is aligned level again.

### Transport Wheels and Stop for Swift Changing of the Location (see figures I1 – I2)

The transport wheels **12** enable the saw stand to be transported to a different location, without having to remove the mounted stationary saw.

The transport wheels **12** can be fastened either to the left or right of the saw stand.

For assembly, use the fastening kit **20**.

- Lay the saw stand upside down on the floor (the folded-in legs facing upward).
  - Screw the transport wheels at the desired location to the saw table with the four screws and nuts.  
Use the provided Allen key **14** for this.
  - Turn around the saw stand to the working position.
  - Loosen the locking knob **3** on the side of the saw stand on which the transport wheels are fastened and pull the table extension **2** lightly outward.
  - Insert the transport stop **11** into the upper groove of the saw stand and slide the transport stop to the attachment set **4**.
  - Firmly tighten the hexagon bolt in the stop with the provided socket spanner **14**.
- When transporting, the attachment set with the mounted power tool can no longer slip off.

### Transport (see figure J)

The saw stand must be folded together for transport.

- In case a support leg **13** is mounted, remove it.
- Slide the table extensions **2** completely inward.
- Tilt all legs inward (press locking pin **15** inward; tilt each leg inward until the locking pin can be heard to engage again).
- Grasp the recessed handle and lift up the saw stand.

## Maintenance and Service

### Maintenance and Cleaning

If the saw stand should fail despite the care taken in manufacture and testing, repair should be carried out by an authorised customer services agent for Bosch power tools.

In all correspondence and spare parts orders, please always include the 10-digit article number given on the type plate of the saw stand.

### Accessories

Attachment set. . . . .	2 610 948 662
Workpiece support. . . . .	1 609 B01 851
Height-adjustable support leg . .	1 609 B01 855
Transport wheel set (wheels, stop, fastening kit). . . . .	1 609 B01 854

### After-sales Service and Customer Assistance

Our after-sales service responds to your questions concerning maintenance and repair of your product as well as spare parts. Exploded views and information on spare parts can also be found under:

**www.bosch-pt.com**

Our customer service representatives can answer your questions concerning possible applications and adjustment of products and accessories.

#### Great Britain

Robert Bosch Ltd. (B.S.C.)  
P.O. Box 98  
Broadwater Park  
North Orbital Road  
Denham  
Uxbridge  
UB 9 5HJ  
Tel. Service: +44 (0844) 736 0109  
Fax: +44 (0844) 736 0146  
E-Mail: boschservicecentre@bosch.com

#### Ireland

Origo Ltd.  
Unit 23 Magna Drive  
Magna Business Park  
City West  
Dublin 24  
Tel. Service: +353 (01) 4 66 67 00  
Fax: +353 (01) 4 66 68 88

#### Australia, New Zealand and Pacific Islands

Robert Bosch Australia Pty. Ltd.  
Power Tools  
Locked Bag 66  
Clayton South VIC 3169  
Customer Contact Center  
Inside Australia:  
Phone: +61 (01300) 307 044  
Fax: +61 (01300) 307 045  
Inside New Zealand:  
Phone: +64 (0800) 543 353  
Fax: +64 (0800) 428 570  
Outside AU and NZ:  
Phone: +61 (03) 9541 5555  
www.bosch.com.au

#### Republic of South Africa

##### Customer service

Hotline: +27 (011) 6 51 96 00

##### Gauteng – BSC Service Centre

35 Roper Street, New Centre  
Johannesburg  
Tel.: +27 (011) 4 93 93 75  
Fax: +27 (011) 4 93 01 26  
E-Mail: bsctools@icon.co.za

##### KZN – BSC Service Centre

Unit E, Almar Centre  
143 Crompton Street  
Pinetown  
Tel.: +27 (031) 7 01 21 20  
Fax: +27 (031) 7 01 24 46  
E-Mail: bsc.dur@za.bosch.com

##### Western Cape – BSC Service Centre

Democracy Way, Prosperity Park  
Milnerton  
Tel.: +27 (021) 5 51 25 77  
Fax: +27 (021) 5 51 32 23  
E-Mail: bsc@zsd.co.za

##### Bosch Headquarters

Midrand, Gauteng  
Tel.: +27 (011) 6 51 96 00  
Fax: +27 (011) 6 51 98 80  
E-Mail: rbsa-hq.pts@za.bosch.com

### Disposal

The saw stand, accessories and packaging should be sorted for environmental-friendly recycling.

**Subject to change without notice.**