



Sig Marine Products
#407-204 Cayer St. Coquitlam
B.C. Canada V3K 5B1
www.sigmarine.com
info@sigmarine.com
T: 800 659 9768



INSTALLATION AND OPERATING MANUAL

Direct Vent P9000

Propane Fireplace/Heater

This manual must be read and the requirements carried out to ensure satisfactory performance.

SIG MARINE RESERVES THE RIGHT TO MAKE CHANGES TO PRODUCTS OR DOCUMENTS AT ANY TIME

QUALITY INSPECTED BY- Doug & Don

DATE- Nov 5/2008

Important

Read this owner's manual carefully and completely before trying to assemble, operate, or service this fireplace. Improper use of this gas appliance can cause serious injury or death from burns, fire, explosion, carbon monoxide poisoning and oxygen depletion.

Save this manual for future reference

Contents

Warnings and Disclosures	pg-2	Electrical	pg-9
General Mounting Information	pg-3	Lighting & Maintenance	pg-10
Mounting Diagrams	pg-5	Troubleshooting	pg-11
Deckcap and Flexpipe Install	pg-6	Part Replacement Inst.	pg-12
Deckcap Diagrams	pg-7	Limited Warranty	pg-13
Gas Supply	pg-8	Warranty Form	pg-14

Heater Parts List

Description

PROPANE FIREPLACE/HEATER

1.5 inch (37.5mm) diameter x 28" aprox Inner S/S Pipe

2.5 inch (63mm) diameter x 28" aprox Outer S/S Pipe

4 spacer springs, installed inside pipe

S/S Double - Direct Vent - Flue Cap - Sealing Gasket - Inner

Dress Ring - mounting screws

S/S Back Mounting Plate (attached to heater)

Warnings and Disclosures

- Follow all installation and operating procedures.
- The propane heater requires an installed flue for correct operation.
Do not attempt to operate the heater without the flue chimney installed correctly as required in this manual.
- If the information in this manual is not followed exactly, a fire or explosion may result causing property damage, personal injury, or loss of life.
- Do not store or use gasoline or other flammable vapors and liquids in the vicinity of this or any other appliance.
- Do not use substitute valves, burners, or fan motors
- Turn off the heater when refueling.
- Do not install this appliance in spaces containing internal combustion engines, fuel tanks, or joints and fittings of their fuel systems.
- Use only approved materials, hose, regulators and fittings to install.
 - 10ft Hose – ULC Type III CGA St 8.1 – Prt# 15205
 - 20ft Hose – ULC Type III CGA St 8.1 – Prt# 15206
 - Propane Low Pressure Regulator UL/C.G.A – Prt# 15203
- Do not store or use gasoline or other flammable vapors and liquids in the vicinity of this or any other appliance.
- Installation must conform with local codes or in the absence of codes, with current National Fuel Gas Code, ANSI Z223.1 or current CAN/CGA B149, Installation Codes.
- Manufactured or mobile home installation must conform to Manufactured Home Construction and Safety Standard, Title 24 CFR, Part 3280, or, when not applicable, the Standard for Fire Safety Criteria for Manufactured Home Installation Sites and Communities, ANSI/NFPA 501A,(USA) or Mobile Homes Standard, CAN/CSA-Z240 MH Series, in Canada
- Main gas valve must be disconnected from gas supply system during any pressure test of the system at pressures greater than ½ psi (3.5 kPa, 27.4mBar)

- DO NOT OPERATE THIS HEATER UNATTENDED !

General

This direct vent heater / fireplace is a clean burning gas appliance for use on board small vessels. The heater is furnished with a double walled vent pipe and cap. Fresh air is pulled from outside, through the outer pipe into the combustion chamber. Exhaust gas leaves the vessel through the inner pipe, while exchanging heat through the wall of the outer pipe to the cabin. Hence, the heater, when properly used and maintained, does not use air from the cabin, nor does it exhaust waste gases into the cabin.

Safety Features

Your heater is equipped with a CGA/AGA approved safety gas valve. Should the flame be extinguished the gas will be shut-off automatically.

Manual ignition involves lighting the heater with the door open and therefore avoids any initial build up of unburned gas.

The installation of a LPG (propane) detector is recommended for all LPG appliances.

Ignition

This unit is ignited manually. A long BBQ lighter is ideal for lighting this appliance.

Fan Assembly

This fireplace insert is equipped with fan assembly. The fan operates manually and has a variable control. The fan circulates heated air from the fireplace into the room. Use of the fan is optional but necessary for best heat transfer.

Mounting the heater

ATTENTION:

Do not attempt to install, operate, inspect or maintain the system until you have read through this instruction manual carefully, have full understanding of all hazards indicated and can use the system correctly.

When installing your new propane heater, keep in mind the following:

Locate the heater where it will maximize the heating capability. This propane heater is equipped with a fan that will blow hot air from the top of the heater down onto the floor.

This increases heating efficiency and provides good circulation of hot air. Mounting the heater lower will allow for more efficient circulation of heat in the cabin.

The flue pipe of this heater is 28" long (71cm). Extensions are available in 10" (25.4cm) and 28". The total length of the flue exhaust pipe can be 56" (2 - 28" lengths) only. Locate your heater so the distance between the heater and the pipe conform to the available pipe lengths. Cutting the flexible pipe to different sizes is very difficult and may destroy the pipe by coming apart (see installing flexible pipe).

Locate the heater to ensure easy access for operation and maintenance.

Locate the heater such that the front and sides of the heater are at least 2 inch (5 cm) away from any surfaces.

Locate the heater such that the bottom of the heater is at least 2 inch (5 cm) from any surface and the top of the heater is 18" (46cm) below any ceiling or deck unless extra steps are taken to insulate the ceiling or deck.

Locate the flue cap where it is not recessed into a deck, wall or siding and where there can be no re-entry of exhaust gasses into the vessel. The mounting flange of the thru fitting and cap requires an area of at least 6" (15cm).

Locate keeping in mind that the top cap gets hot and hot exhaust is being emitted when the heater is operating. If the top cap is installed in an awkward place or position it may be necessary to protect it by installing a cap guard # S19-080 or using a weather guard # S19-200 should it be in a position that is taking on water.

Locate and run the vent pipe such that no low points occur where water or debris can accumulate and thus block the exhaust or intake.

NOTE: The direct vent chimney is flexible and can be bent to provide any angle of offset, see Figure 3. The minimum length recommended is the 28" or 71cm length the heater comes with and the max is 2 lengths of 28". Installing the thru-fitting and flue cap at an angle of no more than 45 degree is not a problem.

Locate for easy, safe access to the source of propane gas.

We do not *recommend* installing the thru-fitting and flue cap with a horizontal exit but if there is no other option the heater will work satisfactorily if the full length of the exhaust pipe supplied (28" / 71 cm) is used to achieve the 90 degree angle. Again keep in mind that the top cap gets hot and that hot exhaust is being emitted when the heater is operating.

Secure the heater mounting plate directly onto the mounting surface. No additional insulation is required. Use appropriate fasteners for mounting.

Avoid low-points in vent pipe

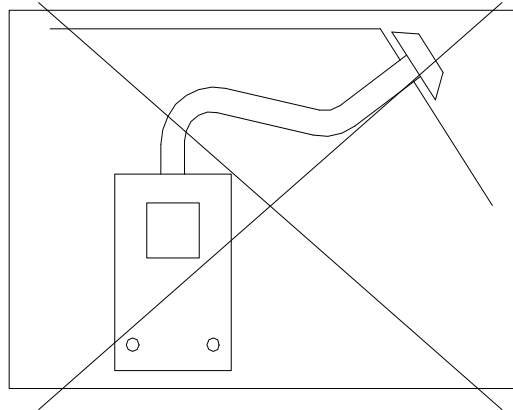
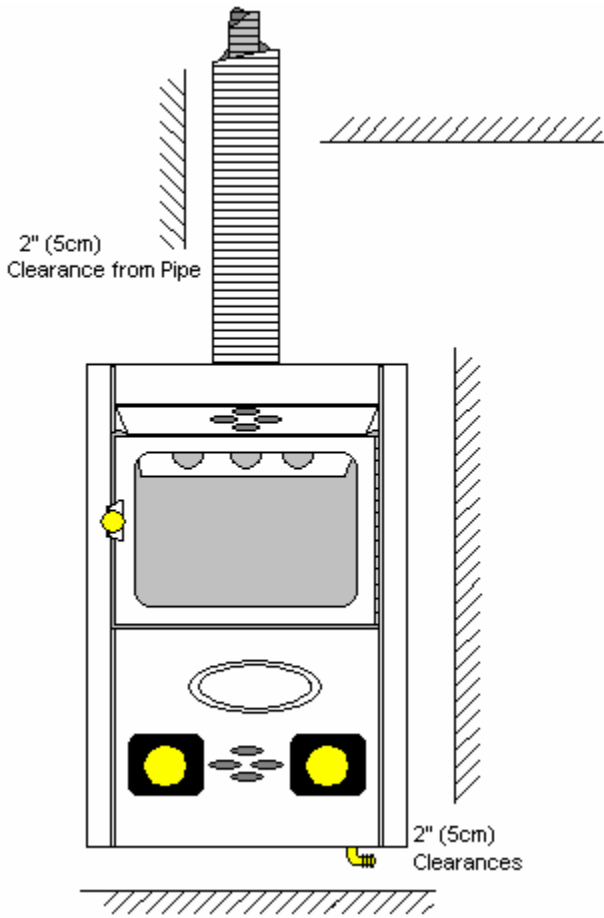

Clearance to surrounding surfaces

Bending and installation of the vent pipe

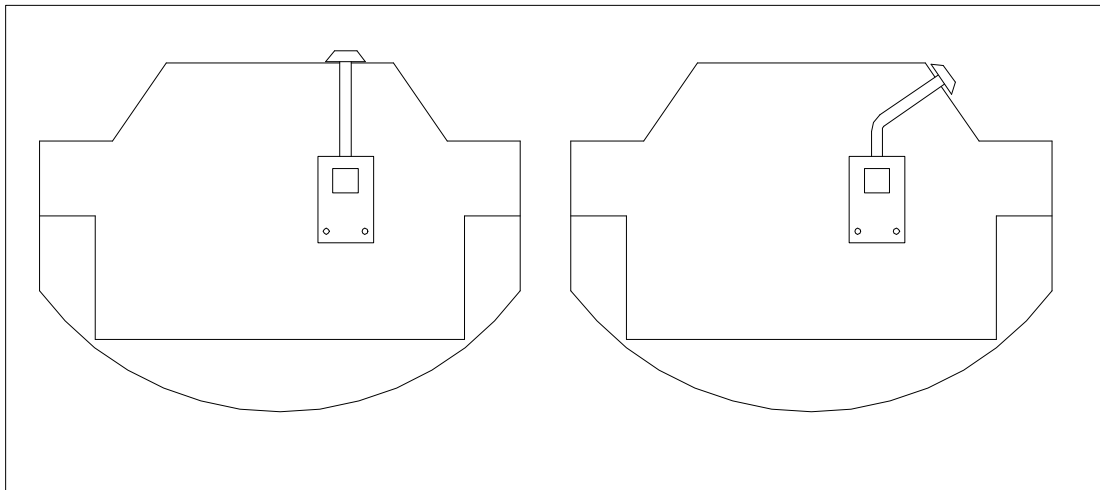

Installing the Flexible Pipe

Four springs are installed between the inside and outside pipe to ensure that an even air space is provided. It is important that two springs be located at any bend in order to prevent the pipes from touching. The length of pipe supplied is approximately 28" (71cm). The pipe can be stretched to provide 1-2 additional inches. Bending the pipe will cause the pipe to stretch.

It is important that the small exhaust pipe is fitted snug on the heater flue collar. Try each end of the pipe and use the end that fits tighter. Once the small pipe is fitted snug then insert the larger pipe (this pipe does not have to fit as tight) Pipes inserted into the cap do not have to fit as snug.

We do not recommend you cut the pipe but the pipe can be cut with a fine hacksaw blade to the required length. Twist the pipe to tighten the pipes flexibility, then tape the end of the pipe and install a hose clamp on the side of the pipe that you are keeping. This is so the clamp is left on the pipe and only removed after or during installing. Cut with fine tooth hack saw blade then use a round file to remove the large burrs in the inside of the pipe.

Caution The flexible pipe can be easily damaged.

Additional 28" (70cm) or 10" (25.4cm) lengths of pipe are sold as an option (Part No. S19-000 and S19-005). A coupling fitting is provided with the optional length.

Installing The Direct Vent Thru-Fitting and Cap

- Step - 1** Measure, and cut or drill a 3" hole through the deck, ceiling or wall where the exhaust cap will be located.
- Step - 2** Make sure the sealing gasket is installed under the above deck-flange before screwing down the fitting. Rotate the fitting to position the pipe seam, inside the boat, so that it is not visible. Holding the deck flange firmly in position secure with the 6 S/S screws supplied.
- Step - 3** Attach the dress ring on the inside, underneath the fitting with the 4 S/S screws supplied. (Make sure that the opening lines up with the underside of the thru-deck or the pipe will not fit correctly).
- Step - 4** Install the flexible pipe on the heater. It is very important that the small pipe fit tightly against the flue collar on the stove, the cap and any other connections.
- Step - 5** Make whatever bends are necessary in the flexible pipe and push into the thru-fitting.
- Step - 6** Secure the heater in position by attaching the back mounting plate.

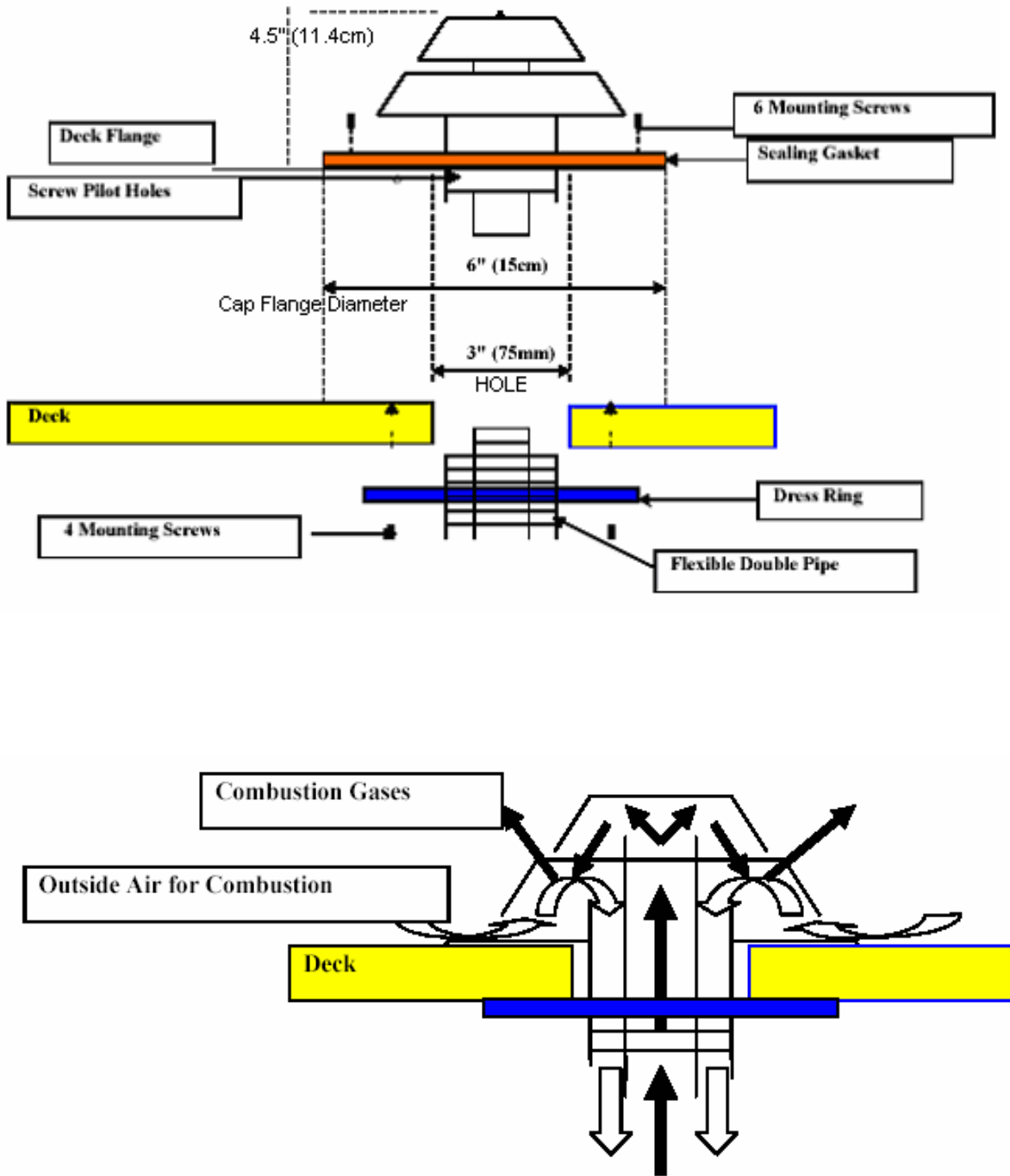

WARNING:

Do not install the external flue cap within 20 inches (500mm) of a refueling fitting or fuel tank vent.

Gas Supply and Connection

The heater operates only on **low pressure** LPG gas (11" w/c / 0.5psi / 27.4 mB).

If there is a propane fuel system installed a separate supply line must be supplied for the heater. This line must be equipped with a low-pressure regulator (Part No. 15203).

Connect to the 3/8" flare connector of the heater with copper or an 3/8 dia. approved hose. During this procedure some particles may get into the fuel line. These could block or restrict the small heater orifice.

Blow out fuel line prior to attaching to the propane supply and the heater.

Disposable Propane Bottle

It is necessary to install a pressure regulator for gas supplied from a propane bottle. For this type of installation we recommend using a Low Pressure Kit (Part No. 15204) This Kit includes a pressure regulator (11 inch W/C) and a mounting kit. The kit must be mounted outside. An AGA/CGA propane hose can be used to connect this Kit to the heater. Hoses are available in 10 ft (3m) (Part No. 15205) or 20 ft (6m) (Part No. 15206)

	<p>ATTENTION , DANGER:</p> <ol style="list-style-type: none">1. Never connect propane/LPG heater directly to the propane/LPG supply. This heater requires an external regulator (not supplied). Install the external regulator between the heater and propane/LPG supply.2. After gas hook-up and before lighting the heater, test all gas lines and connections for leaks with a soap solution.
--	--

Typical LPG on-board system

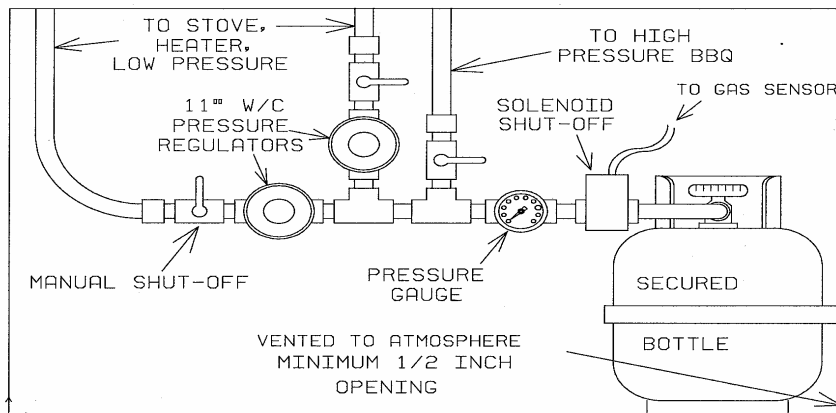

- The diagram is to illustrate a typical installation only and should not be used to illustrate any particular regulatory code, insurance requirement or to override manufacturer's instructions on any fittings or components.
- Install your propane system in accordance to local, national or industry specific regulations.
- Retain the installation and owner's manual for your gas components such as the solenoid and regulator. Installation requirements for some of these components vary by manufacturer. Install components as directed by manufacturer's instructions.

Electrical

- The fan is 12VDC and the power supply must be brought to the wire connectors of the fan ON/OFF switch through the grommet installed. The fan on this heater is CE approved and EM compliant for FCC and CSA regulations. The fan must have an inline fuse rated at 2 amps
- Use of the blower fan is optional but greatly enhances heat output and hot air circulation.
- If applicable, this appliance must be electrically grounded in accordance with local codes or in absence of local codes, with the *National Electrical Code, ANSI/NFPA 70, or the Canadian Electrical Code, CSA C22.21.*

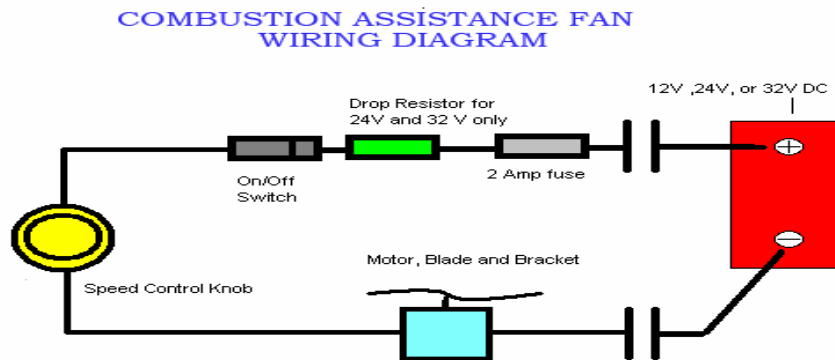

	<p>WARNING: DO NOT touch the heater during operation: the glass window, external surfaces and the vent pipe of the heater get very hot and may cause burns.</p>
	<p>ATTENTION: NOTE: ONLY ON FIRST LIGHTING the lubricating oil on the stainless steel pipe will produce smoke and burn off. THIS IS NORMAL. We suggest that windows and hatches be opened. Smoke from the inside pipe will be emitted outside, through the flue cap.</p>
	<p>WARNING: NOT closing the door of the heater properly may cause</p> <ul style="list-style-type: none">• depletion of oxygen within the cabin• exhaust gas to enter the cabin, possibly including Carbon Monoxide (CO). <p>Carbon Monoxide (CO) is a colorless, tasteless, invisible toxic gas, which can cause serious health problems or death.</p>

- 1) **Open heater door**
- 2) **Turn GAS knob to LOW (only)**
- 3) **Depress knob and light burner manually (It may be necessary to keep clicking the lighter in order to keep the flame going to overcome the strong draft).**
- 4) **Keep knob depressed for 20/25 seconds (once the flames will stay on). Close heater door VERY SLOWLY as it may want to go out when the door is almost closed (slow motion).**
- 5) **Release knob after door is closed and flames should remain lit. (Leaving the heater door open after ignition could cause the flame to go out when the knob is released). Should the flames go out then turn off the gas control valve and wait a few minutes to cool then start over.**
- 6) **The HIGH setting may be selected after a minute or two of warm up.**

Burning Characteristics

On each lighting, the heater flames will create a roaring sound for about 5 minutes until the direct draft system stabilizes and reaches operating temperature. Initially the flame is extremely blue and vibrant. After a short period of time the flames will increase in size and become less vibrant with more yellow tips. This will create more of the fireplace effect. Selecting Low or High settings will only make a small difference to the height of the flame. However, at high the heater is burning 40% more fuel than at low and producing 40% more heat. At the high setting the baffle at the top of the combustion chamber will glow red. This is normal and maximizes the efficiency of the heater.

Cleaning & Maintenance

To keep the heater operating safely and trouble free, it is recommended to periodically perform the following simple inspections:

1. Clean the outside of the heater to maintain the shining appearance of the stainless steel. Use a soft, non-flammable cleaning agent.
2. Refrain from using steel wool or any metal abrasive as this leaves impurities behind.
3. Inspect the propane supply system and tank for age and wear.
4. If the flame is becoming lower and lower over time or suddenly becomes very low, inspect the orifice of the heater. Accumulations of dirt and moisture inside the orifice can build over time and can be removed if they obstruct the orifice.

Troubleshooting

WARNING: WHAT TO DO IF YOU SMELL GAS

- Shut off gas supply.
- Do not try to light any appliance.
- Do not touch any electrical switch; do not use any phone in your vessel.
- Leave the boat and ventilate with the appropriate equipment.
- Locate the cause of the leak and repair.

Observed Problem	Remedy
No gas to burner on lighting	Check gas supply, regulator, solenoid
	Check that knob is exactly at 9 o'clock when depressed
	Orifice is clogged due to dirt build up or material in new hose installation.
Fire does not stay lit when knob released	Depress knob, light burner and almost close door. Release knob and then CLOSE COMBUSTION CHAMBER DOOR
	Check that the door seal is good
	Check that the internal exhaust pipe is installed correctly
	Loosen, clean and tighten brass nut inside door, lower left
Fireplace shuts off during use	No gas supply – check gas pressure
	Blockage of the air intake – check the vent pipe for any object, including water that may block the intake.
Fan does not work	Check power supply (12 V DC)
	Check connection of wires
	Check proper functioning of switch
	Replace fan
Gas odor even when control knob is in OFF position	1. Gas leak. See Warning statement Locate and correct all leaks
	2. Check and, if required, replace the control valve. If operation is attempted with high pressure gas, the valve could fail.
Slight smoke or odor during initial operation	This is a normal event, caused by burning off of residues from the manufacturing process. Smoke and odor should stop after a few hours of operation
If the glass door gets sooty	The small exhaust pipe is not fitting snug on the heater flue collar

Additional Accessories

S19-000	28 inch (70cm) Direct Vent Pipe Extension Kit
S19-005	(approx.)including coupling 10 inch (25.4cm) Direct Vent Pipe Extension Kit (approx.)including coupling
15203	Low pressure regulator only
15204	Low pressure regulator and mounting kit (For use when there is no onboard propane system - for use with propane bottles)
15205	10ft (3 m) CGA/AGA propane hose
15206	20ft (6 m) CGA/AGA propane hose
S01-031	Fan
S01-074	Control for fan
S01-073	On and off switch
S19-030	Stainless steel flue guard
S19-080	Double exhaust cap guard
S02-014	Thermocouple

Thermocouple and Orifice Cleaning Instructions

1. To replace the thermocouple or cleaning the orifice on the heater the front cover must be removed. Remove the brass knobs with a 5/64 Allen wrench along with the nuts holding the black plates.
2. Next remove all the screws on the sides of the heater (careful- hold on to the front cover and remove the top and bottom). Open the door wide and pull back slightly from the front cover to remove the 2 connectors on the rocker switch (use needle nose pliers).
3. Using a 5/16 wrench disconnect the brass nut at one end of the thermocouple, located on the back of the control valve. The other end of the thermocouple is located on the front just below the door opening and a little to the left. Remove the 2 Robertson socket screws and take out the old thermocouple.
4. Connect the new thermocouple to the little bracket and re install it to the front panel making sure the thermocouple is in as deep as it can be mounted to insure the flame will burn close enough to the tip. Install other end into the back of the valve. This is not a part of the propane system so no need to worry about leaks.
5. To clean the orifice, remove the copper fuel line at the front of the heater just below the door opening, then loosen the lock nut and remove the brass fitting from the heater. The orifice is located in the brass fitting. Clean the hole with a wire smaller than a paper clip or try compressed air. Assemble in reverse order. Use loctite or similar on the brass fittings for vibration purposes.

Limited Warranty

- **WARRANTY PROVISIONS:** **Sig Marine** warrants this product to be free of defects in workmanship and materials for a period of one year. This warranty is limited to claims submitted in writing within a one-year period following the date of purchase. If any part of your new product fails because of a manufacturing defect within the warranty period **Sig Marine** offers to replace said parts free of charge provided, however, that such parts have not been improperly repaired, altered or tampered with or subjected to misuse, abuse or exposed to corrosive conditions. This warranty however, is limited to certain exclusions, time limits and exceptions as listed below. Read these limitations and exclusions carefully.

TIME LIMIT: This warranty is given too and covers only the original purchaser. Coverage terminates one year from the date of purchase for parts replacement.

EXCLUSIONS: This warranty does not cover or include: (a) Any normal deterioration of the product and appearance of items due to wear and/or exposure; (b) any guarantees, promises, representations, warranties or service agreements given or made by an authorized distributor or other person selling this product, other than those specifically stated herein; (c) any damage or reasonable and necessary maintenance, misuse or abuse of the equipment, or exposure to corrosive conditions. This warranty is conditional upon normal use, reasonable and necessary maintenance and service of your product, and written notice being given promptly upon Buyer's discovery of a warranty claim, pursuant to paragraph 6 below. Reasonable and necessary maintenance is maintenance which you are expected to do yourself or have done for you. It is maintenance, which is necessary to keep your product performing its intended function and operating at a reasonable level of performance.

DAMAGE LIMITATIONS WARRANTY : IN NO EVENT SHALL **Sig Marine** BE LIABLE FOR ANY INCIDENTAL OR CONSEQUENTIAL DAMAGES, INCLUDING (BUT NOT LIMITED TO) LOSS OF USE OF THE PRODUCT, LOSS OF TIME, INCONVENIENCE, EXPENSES OR TRAVEL, LODGING TRANSPORTATION CHARGES, LOSS BY DAMAGE TO PERSONAL PROPERTY OR LOSS OF INCOME, PROFITS OR REVENUE.

ORAL OR IMPLIED WARRANTY LIMITATIONS: The foregoing warranty is exclusive and in lieu of all other warranties, written or oral, expressed or implied, including but not limited to any warranty or merchantability or fitness for a particular purpose.

TRANSFER LIMITATIONS: This warranty is not assignable or transferable. It covers only the original purchaser.

CLAIM PROCEDURE: In the event of a defect, problem or that a breach of this warranty is discovered, in order to protect any warranty rights you must promptly notify **Sig Marine**. Give name and address, model name, location of unit, description of problem and where you can be reached during business hours.

RESERVED RIGHT TO CHANGE: **Sig Marine** reserves the right to make changes or improvements to products in the future without imposing on itself any obligations to install the same improvements in the products it has previously manufactured.

SECOND OR SUBSEQUENT OWNER: **Sig Marine** does not give any warranty to secondary or subsequent purchasers, and it disclaims all implied warranties to such owners.

INSPECTION: To assist you in avoiding problems with your product and to validate this warranty you are required to do the following: (a) read the warranty; (b) inspect the product. Do not accept delivery until you have examined the product with your supplier; (c) ask questions about anything you do not understand concerning the product.

OWNER REGISTRATION: Fill out the **WARRANTY CARD** within 30 days from the date of delivery.

WARRANTY: RETURN OF THE CARD IS CONDITION PRECEDENT TO WARRANTY, COVERAGE AND PERFORMANCE. IF YOU DO NOT FILL OUT AND MAIL THE CARD AS DIRECTED YOU WILL NOT HAVE A WARRANTY.

LEGAL RIGHTS: This warranty gives you specific legal rights and you may also have other rights, which may vary within different government jurisdictions.

Return to:



#407 – 204 Cayer Street, Coquitlam, B.C. Canada V3K 5B1

WARRANTY FORM

I have read and understand the Limited Warranty and the Instruction Manual and agree to the terms and conditions

(please print)

Date.....

Purchaser's Name.....

Address.....

.....

Model Name.....**SIG...DVP9000...Propane...Fireplace/Heater**.....

Serial Number.....

Date Of Purchase.....

Signature.....

Name of Seller.....

Seller Location.....