

MASTER[®]

IT - Generatore d'aria Calda
GB - Hot air generator
DE - Warmlufterhitzer
ES - Generadores de aire caliente
FR - Générateurs d'air chaud

*Libretto uso e manutenzione - Operation and maintenance manual -
Bedienungsanweisung - Manual del propietario - Manuel de L'utilisateur*



4031.812



GREEN 70
GREEN 115
GREEN 200

QUADRO COMANDI - CONTROL BOARD - KONTROLLTAFEL - TABLEAU DE COMMANDE - TABLERO DE MANDOS

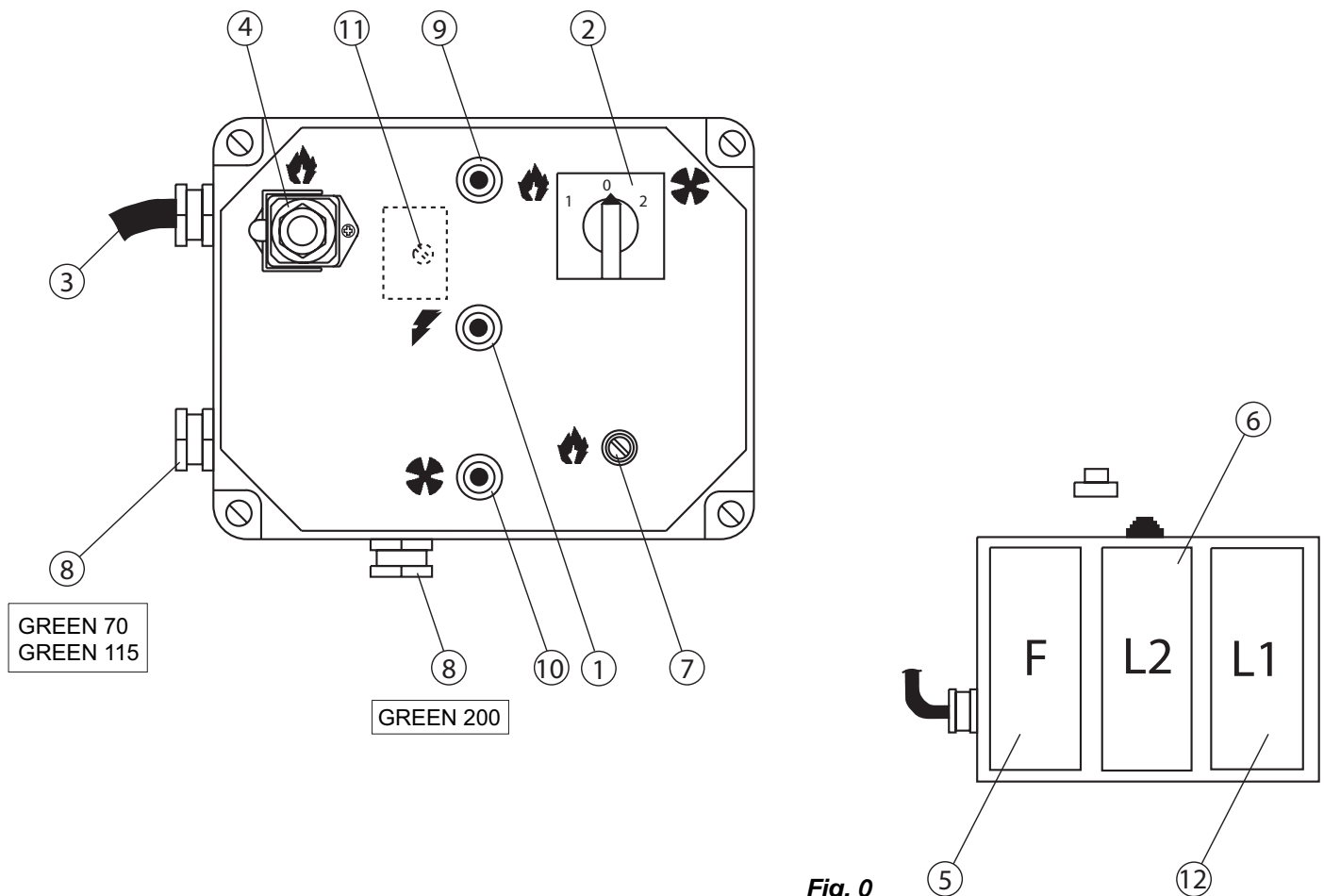

Fig. 0

- | | |
|---|--|
| <p>1. Spia tensione quadro - Control lamp - Kontrollampe - testigo tensión tablero - Lampe témoin mise sous tension</p> <p>2. Interruttore - Control knob only - Schalter - Conmutador - Commutateur</p> <p>3. Cavo alimentazione elettrica - Power cord - Elektro kabel - Cable alimentación - Cable électrique alimentation</p> <p>4. Presa per bruciatore - Burner plug - Sicherungsschalter für Brenner - Enchufe para quemador</p> <p>5. Termostato ventilatore - Fan thermostat - Luftregler - Termostato ventilador - Thermostat ventilateur</p> <p>6. Termostato di sicurezza a riarmo manuale - Limit thermostat with manual restart - Sicherheitsthermostat mit manueller entriegelung - Termostato de seguridad con restablecimiento manual - Thermostat de securite a rearmement manual</p> | <p>7. Porta fusibile per bruciatore - Burner fuse holder - Sicherungsschalter für Brenner - Porta fusible para quemador</p> <p>8. Pressacavo per termostato ambiente - Cable fastener for room thermostat - Raumthermostat kabel führung - Prensa cable para de termostato ambiente - Presse etoupe pour thermostat d'ambiance</p> <p>9. Spia termostato di sicurezza - Overheat thermostat control lamp - Überhitzungsschutz kontrollampe - Testigo termostato de seguridad - Lampe témoin securite de surchauffe</p> <p>10. Spia blocco ventilatore - Fan stop control lamp - Ventilator "aus" kontrollampe - Testigo bloqueo ventilador - Lampe témoin arret ventilateur</p> <p>11. Riarmo ventilatore - Fan reset - Ventilator entriegelungsschalter - Restablecimiento ventilador - Rearmement ventilateur</p> <p>12. Termostato di sovratemperatura - Overheat safety thermostat - Überhitzungsschutz Thermostat - Termostato de sobretemperatura - Thermostat de securité de surchauffe</p> |
|---|--|

DESCRIPTION

Warning: Only the burners which are chosen and supplied by the manufacturer can be used. If another type of burner is used the heater no longer complies with CE regulations.

GREEN space heaters have been designed for use in small to medium-sized rooms and buildings where a fixed or mobile heating system is required.

Heat is produced by combustion and the heat from the smoke is transmitted to the fresh air through the metal walls of the combustion chamber and the heat exchanger. The combustion chamber is of the type where smoke circulates twice.

The air and smoke pass through separated ducts, both of which are welded and sealed. When, after combustion, the waste gases have cooled, they are expelled through a duct which must be connected to a chimney or chimney flue. The chimney or chimney flue must be big enough to guarantee that the smoke is expelled efficiently.

The air which is used in combustion is aspirated directly from the room or building which is being heated. It is therefore of utmost importance that the room or building be properly ventilated so that enough fresh air is circulating at all times.

GREEN heaters can operate with burners that are fuelled by heating oil, methane (G20) or L.P.G. (butane G30 and propane G31) of the ON-OFF type.

There are three safety devices which are activated in case of serious malfunction. The Burner Control Device, which is mounted on the burner and has a restart button, automatically stops the burner if the flame goes out. The Overheat Thermostat, L2, of the manual restart type, is activated if the temperature of the combustion chamber rises above the set maximum limit; the warning light (9) lights up and the heater stops working. The Thermal Relay, RM, is activated if the fan motor starts to use more electrical current than the maximum permitted limit; the warning light (10) lights up and the heater stops working.

If any of these safety devices are activated you should check carefully what the problem actually is before pressing the restart button and starting the heater off again ("OBSERVED FAULTS, CAUSES AND REMEDIES"). Overheat safety thermostat, L1, shuts down the heater if air flow is not sufficient to cool off combustion chamber: the heater will restart automatically as soon as the heater has cooled down enough (the lamp(9) lights up and then it cuts down).

GENERAL ADVICES

The space heater must be installed, set up and used in accordance with existing laws.

Here are a few general guidelines which should be followed:

- Follow the instructions in this booklet very carefully;
- Don't install the heater in places where there may be a risk of fire or explosion;
- Inflammable material should be kept at a safe distance from the heater (Minimum 3 meters);
- All fire prevention regulations must be adhered to;
- The room or building which is being heated must be sufficiently ventilated so that the heater has enough air to function properly;
- The heater must be near a chimney or chimney flue and a suitable electric switchboard;
- Don't let animals or children near the heater;

- After use make sure the disconnecting switch is off. When using any type of space heater it is obligatory;
- not to exceed the maximum level of heat output of the furnace ("TECHNICAL SPECIFICATION TABLE");
- to make sure that there is adequate air circulation and air supply to the heater and that nothing is obstructing the aspiration and expulsion of air; movement of air may be obstructed in various ways including placing covers or other objects on the heater or positioning the heater too near a wall or other large object. If the airflow is not adequate, the combustion chamber will over heat and the overheat safety thermostat L1 will turn the burner off and on continuously ("OBSERVED FAULTS, CAUSES AND REMEDIES").

INSTALLATION

Warning: The following operations must be carried out by qualified personnel only.

ELECTRICAL CONNECTIONS AND SETTINGS

Warning: The mains supply to the heater must be earthed and have a magneto-thermal switch with differential. The power cord must be connected to a switch board which has a disconnecting switch.

Every space heater is supplied along with the safety and control devices which are indispensable to the correct functioning of the unit. The electric switchboard, burner, the fan thermostat, over heat safety thermostat and the overheat thermostat with manual restart have already been connected.

The following operations must now be carried out:

- Plug in the power cord having read the adhesive label which details electricity supply characteristics (Table 1). Table 2 shows the adhesive label on units which have three-phase supply;

	Model M - M/C	Model T - T/C
Number of phases	1	3
Tension [V]	230	230/400
Frequency [Hz]	50	50

Tab. 1

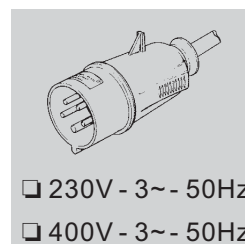

Tab. 2

- The burner must be connected to the fuel supply ("Burner Instruction Manual");
- Connect the burner to the electricity supply with the burner plug;
- Connect accessories such as the room thermostat or clock to the unit's electric switchboard: electric wire must be connected by means of the cable fastener (8) to the terminals (6) and (7). Having completed all these operations check carefully that all electrical connections correspond to the wiring diagram. When the heater is first turned on you must check that the fan does not use more current than the maximum permitted limit. Finally, to

regulate the burner follow the instructions in the Burner Instruction Manual.

CONNECTION TO HOT AIR DUCTS

The space heater provides heat by releasing and dispersing hot air. An air head is supplied with each unit and it can be connected to new air ducts if the user wishes to satisfy specific needs. In this case and in particular if the diameter and length of the ducts have been changed or if the number of bends has been modified, air output may vary. Consequently it is very important to check and regulate air output when any modification is made to air heads or air ducts. In all circumstances you must ensure that:

- The fan motor does not absorb more current than the maximum permitted limit;
 - The volume of air flow corresponds to the recommended level.
- If the heater is equipped with centrifugal fan and if the volume of hot air differs from preset values proceed as follows (Fig.1):
- 1) Remove the aspiration grill which is on fan motor side of the unit;
 - 2) Remove the screws (2) from the motor slide.
 - 3) Remove the belt (1);
 - 4) Loosen the bolts (3);
 - 5) Turn the pulley clockwise and anti-clockwise in order to increase or reduce the volume of air;
 - 6) Tighten the bolts (3);
 - 7) Put back the aspirations grill;
 - 8) Repeat operations (1) -(7) until the correct volume of air flow has been achieved.

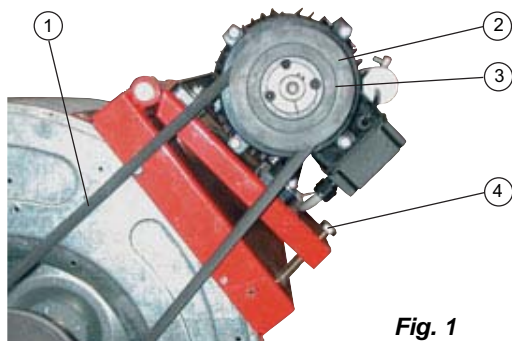

Fig. 1

DRAFT

Efficient combustion and trouble-free working of the burner depend on efficient flue draft. The unit must be connected to the chimney flue in accordance with current legal regulations and in line with the following guidelines:

- The tube which carries the smoke should cover as short a distance as possible and should slant upwards;
- There should be no sharp bends in the tubes and the diameter of the tubes must never be reduced;
- Every heater must have its own chimney;
- Flue draft must at least correspond to the minimum compulsory level in the Technical Specifications.

ANALYSIS OF COMBUSTION WASTE PRODUCTS

The probes which check the composition of combustion waste products and smoke temperature must be positioned as indicated in Fig.2.

When these tests have been completed the hole which was drilled for the probe must be sealed with a material which is resistant to high temperatures and which ensures that the tube remains airtight.

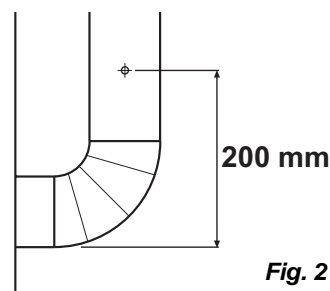

Fig. 2

CONNECTION TO FUEL SUPPLY AND CHANGING FROM ONE TYPE OF GAS TO ANOTHER

To connect the burner to the fuel supply follow the instructions in the Burner Instruction Manual.

The burner can use both methane gas and L.P.G. The gas used to predispose the heater at factory has been declared on data plates applied on the box and on the heater itself (methane, G20, or L.P.G., G30, G31).

To change from methane gas to L.P.G. or vice-versa you must:

- adapt the burner following the instructions manual;
- repeat regulation of combustion while composition of combustion waste products are checked.
- correct data plate on the heater writing which type of gas must be used.

REGULATION OF COMBUSTION - 1° OPERATION

After having checked the hermetic seal of line and of combustion waste products line, heater may be operated for the first time.

To perform regulation of combustion correctly, combustion waste products must be analyzed using appropriate instruments: values recommended by actual standards must be reached.

Adjustments to be carried out are described in the Burner Instruction Manual; final values of CO₂ shall be correspondent to excess air factor of 1,2 (12,5% for gas-oil, 9,7% for G20, 9,6% for G25, 11,7% for G30 and 11,7% for G31) while CO level shall be less than 75 ppm.

INSTRUCTIONS FOR USE

SWITCHING ON

- Set the control knob (2) in position "0";
- Turn on the disconnecting switch on the electric switchboard;
- If the unit is operated manually turn the control knob to 🔥. The burner starts up, the combustion chamber heats up and then the fan starts;
- If the unit operates automatically set the room thermostat at the desired level and turn the control knob (2) to 🔥: the heater will now start and stop automatically.
- If the heater doesn't start after you have completed the above operations consult the Troubleshooting section of this manual.

TURNING OFF

Warning Never stop the heater by simply turning off the disconnecting switch on the electric switchboard. The electrical supply must only be disconnected when the fan has come to a complete stop.

In manual operation turn control knob (2) to "0" or turn off control in automatic operation.

The burner stops while the fan turns itself on and off until the combustion chamber has completely cooled down.

VENTILATION

When the control knob is turned to the symbol  the heater operates in continuous fan mode.

MAINTENANCE

WarningThe following operations must be carried out by qualified personnel only.

Before carrying out any maintenance operation the heater must be disconnected from the mains. Therefore:

- Stop the machine as instructed above
- Turn off the disconnecting switch on the electric switchboard
- Wait until the heater has cooled.

CLEANING THE HEAT EXCHANGER AND THE COMBUSTION CHAMBER

For the heater to operate efficiently the heat exchanger and combustion chamber must be cleaned after a period of prolonged use and more frequently if too much soot builds up. Soot builds up when there is not enough chimney draft, when the fuel is of very poor quality, when the burner is regulated incorrectly or when the heater is switched on and off too frequently. If the heater starts vibrating when it is turned on there is probably too much soot.

To get at the heat exchanger (1) take off the front panel (3) and then remove the smoke box panel (2) and remove baffle plates (7). To get at the combustion chamber (4) remove the burner (5).

CLEANING THE FAN

Remove any dirt or extraneous material from the mesh of the aspiration grill (6) and if necessary clean the propeller with an air-suction tool.

CLEANING THE BURNER

For the heater to work efficiently the burner must be serviced regularly by an Authorized Service Technician. All cleaning, servicing and regulation operations must be carried out as indicated in the Burner Instruction Manual.

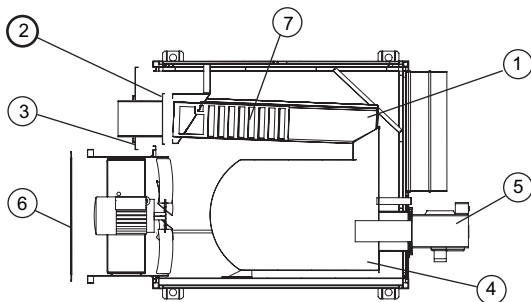

Fig. 3

TRANSPORTING AND MOVING THE HEATER

Warning: Before moving a unit:

- Turn it off as indicated above
- Disconnect electricity by pulling out the plug
- Wait until the heater cools down

The heater has four hooking points at the four top corners. The heater should be moved or lifted by means of ropes or chains connected to the hooking points.

The heater can be:

- suspended with ropes and/or chains or supporting beams
 - mounted on a supporting base.
- In both cases check carefully in the Technical Specifications that all parts of the heater can take the strain of lifting.
Warning: Never try to lift the heater manually. Doing so could result in physical injury.

OBSERVED FAULTS, CAUSES AND REMEDIES

Problem	Cause	Remedy
The heater won't start	<ol style="list-style-type: none"> 1. Faulty electrical supply 2. Wrong positioning of main switch 3. Wrong setting of room thermostat 4. Safety device (burner, thermostat L) not restarted after repairs 	<ol style="list-style-type: none"> 1. Check function and positioning of main switch 1. Check power cord 1. Check electrical connections 1. Check fuses 2. Put main switch in correct position 3. Check setting of room thermostat 3. Check function of room thermo-stat 4. Press the appropriate restart button
Thermostat L cuts in (the lamp (9) light up and then it cuts down)	<ol style="list-style-type: none"> 1. The combustion chamber has overheated 	<ol style="list-style-type: none"> 1. Check fuel flow 1. Check position registers, draw-holes, etc. 1. Remove extraneous material from air ducts and ventilation grills
Thermostat L2 cuts in (Warning lamp (9) lights up)	<ol style="list-style-type: none"> 1. Excessive combustion chamber over heating 	<ol style="list-style-type: none"> 1. Check as indicated above 1. If fault persists contact our Service Center
Thermal relay RM cuts in (warning light (9) lights up)	<ol style="list-style-type: none"> 1. Fan current absorption is excessive 	<ol style="list-style-type: none"> 1. Heater with helicoidal ventilator: remove eventual debris preventing free flow of air on intake and outlet. Check length of air ducts, reduce if excessive. 1. Heater with centrifugal ventilator: check setting of transmission belt as indicated in chapter ("CONNECTION TO HOT AIR DUCTS"). 1. Always check that current absorption remains below value indicated on motor manufacturer plate
The burner starts up, the flame doesn't light up and the restart light comes on	<ol style="list-style-type: none"> 1. Burner not working correctly 	<ol style="list-style-type: none"> 1. Press the restart button to turn on the heater. If the same problem arises again call an Authorized Service Technician
The fan doesn't start up or starts up late.	<ol style="list-style-type: none"> 1. No electrical power 2. F thermostat out of order 3. Winding of motor burnt or interrupted 4. Condenser burnt 5. Motor bearings blocked 	<ol style="list-style-type: none"> 1. Check fuses 1. Check electrical connections 2. Check the thermostat, set it and replace it if necessary 3. Replace the fan motor 4. Replace the condenser 5. Replace the bearings
The fan vibrates or makes unusual noise	<ol style="list-style-type: none"> 1. Extraneous material on fan blades 2. Not enough air circulation 	<ol style="list-style-type: none"> 1. Remove extraneous material 2. Remove obstacles to air circulation
Not enough heat	<ol style="list-style-type: none"> 1. Wrong burner 	<ol style="list-style-type: none"> 1. Call an Authorized Service Technician

IMPIANTO ELETTRICO - ELECTRICAL DIAGRAM - ELEKTRO SKEME
 DIAGRAMA ELÉCTRICO - DIAGRAMME ÉLECTRIQUE

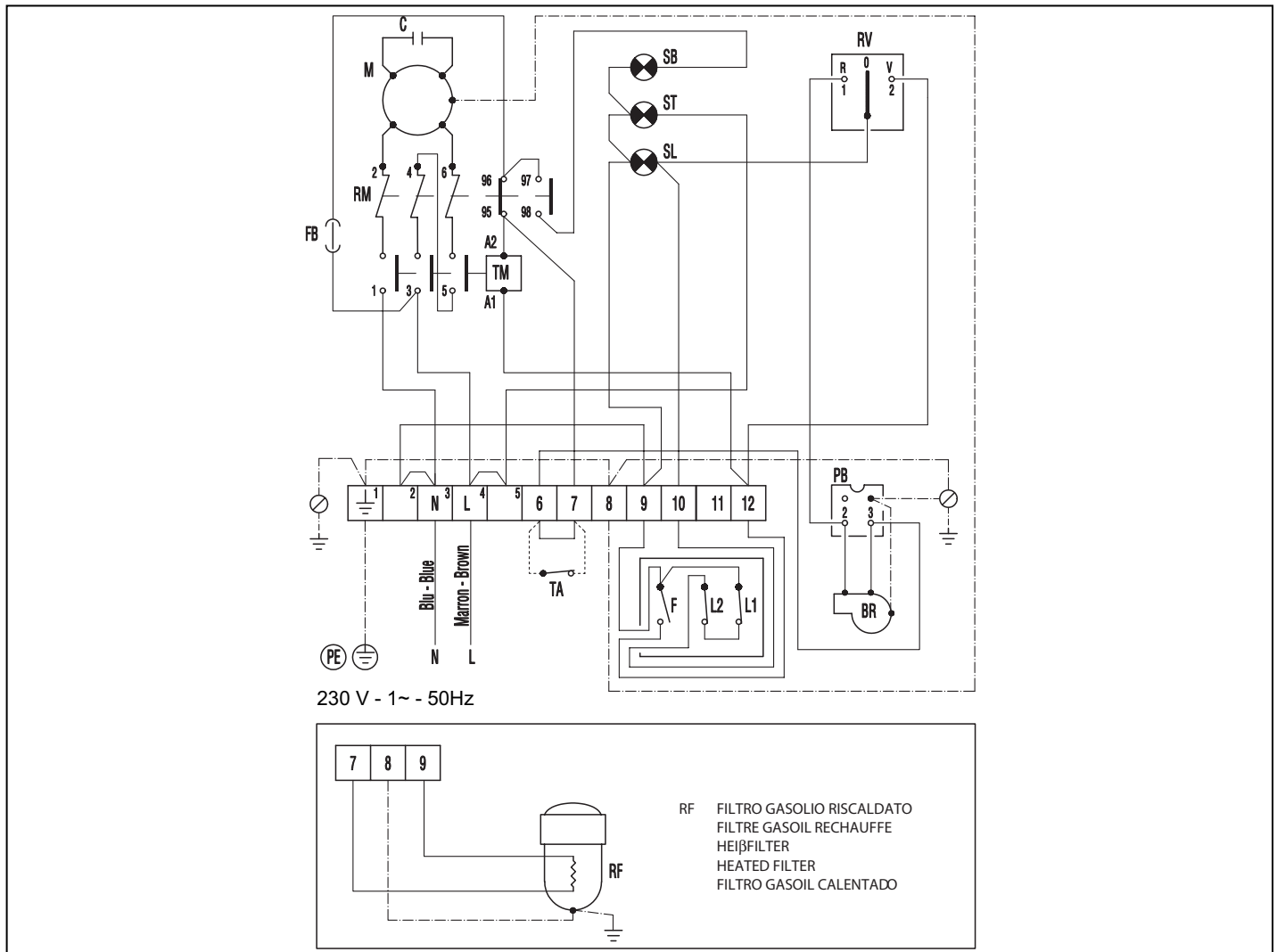

M MOTORE VENTILATORE - FAN MOTOR - VENTILATOR MOTOR - MOTOR VENTILADOR - MOTEUR VENTILATEUR

RM RELÈ TERMICO VENTILATORE - FANS THERMAL RELAY - THERMOLAIS FÜR VENTILADOR - RELÈ TÉRMICO VENTILADOR - RELAIS THERMIQUE DES VENTILATEUR

F TERMOSTATO VENTILATORE - FAN THERMOSTAT - LUFTREGLER - TERMOSTATO VENTILADOR - THERMOSTAT VENTILATEUR

ST SPIA TENSIONE QUADRO - CONTROL LAMP - KONTROLLAMPE - TESTIGO BLOQUEO VENTILADOR - LAMPE TEMOIN MISE SOUS TENSION

FB FUSIBILE BRUCIATORE - BURNER FUSE - SICHERUNG FÜR BENNER - FUSIBLE QUEMADOR - FUSIBLE BRULEUR

SB SPIA BLOCCO VENTILATORE - FAN STOP CONTROL LAMP - VENTILADOR "AUS" KONTROLLAMPE - TESTIGO BLOQUEO VENTILADOR - LAMPE TEMOIN ARRET VENTILATEUR

TM TELERUTTORE VENTILATORE - FANS TELE-CONTACTOR - FERNSCHALTER FÜR VENTILADOR - TELERUPTOR VENTILADOR - TELERUPTEUR VENTILATEUR

BR BRUCIATORE - BURNER - BRENNER - QUEMADOR - BRULEUR

**IMPIANTO ELETTRICO - ELECTRICAL DIAGRAM - ELEKTRO SKEME
DIAGRAMA ELÉCTRICO - DIAGRAMME ÉLECTRIQUE**

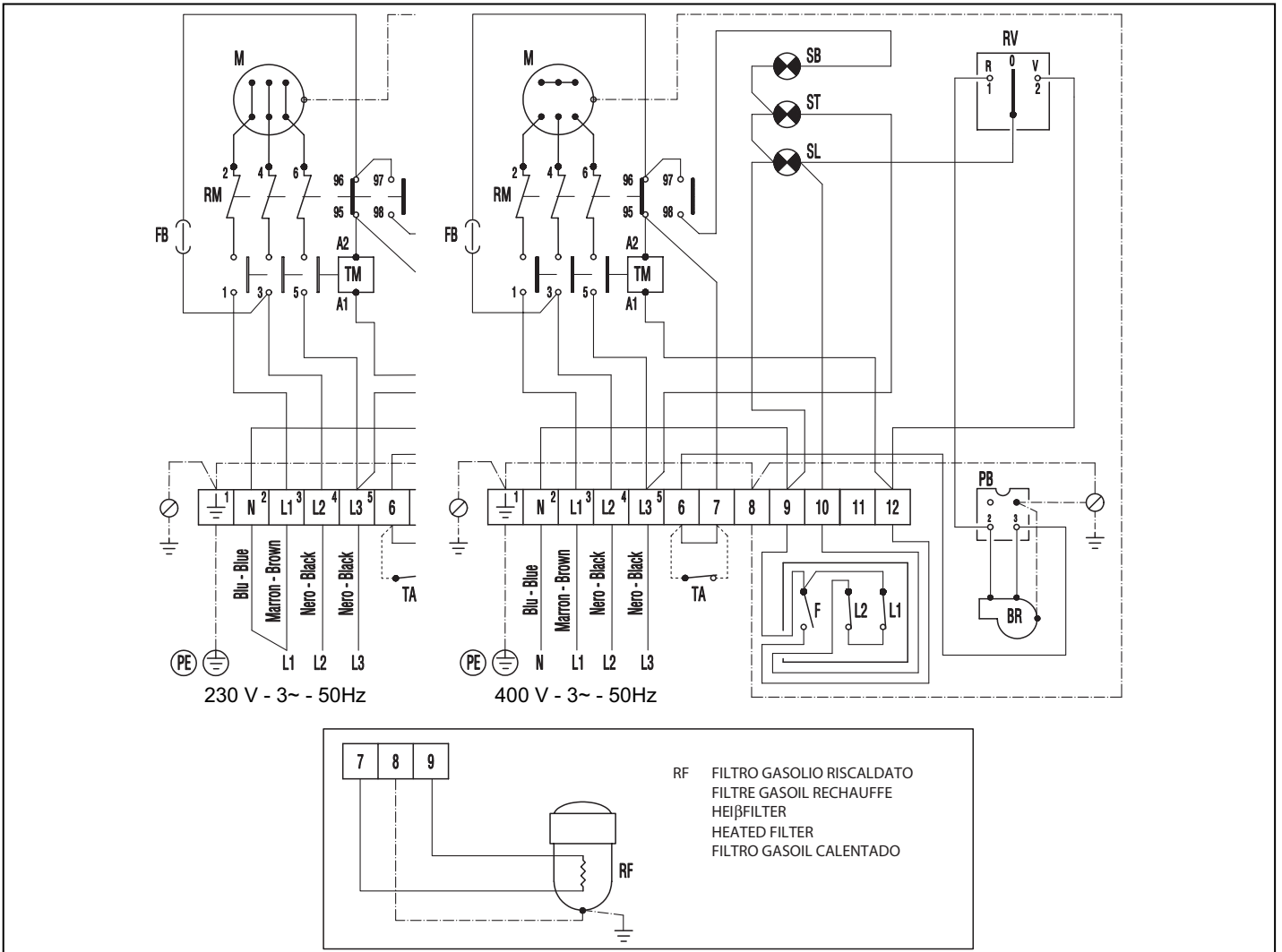

- TA** TERMOSTATO AMBIENTE - ROOM THERMOSTAT
- RAUMTHERMOSTAT - TERMOSTATO AMBIENTE -
THERMOSTAT D'AMBIANCE
- RV** INTERRUTTORE ON / OFF / VENTILAZIONE - CONTROL
KNOB HEAT / STOP / VENTILATION ONLY - SCHALTER
HEIZUNG / STOP / LÜFTUNG - COMMUTADOR CALEFAC-
CIÓN / PARO / VENTILACIÓN - COMMUTATEUR CHAUF-
FAGE / STOP / VENTILATION
- C** CONDENSATORE - CONDENSER - KONDENSATOR
- CONDENSADOR - CONDENSATEUR
- SL** SPIA TERMOSTATI DI SICUR. - OVERHEAT THERMOSA-
TS CONTROL LAMP - ÜBERHITZUNGSSCHUTZEN KON-
TROLLAMPE - TESTIGO TERMOSTATOS DE SEGURIDAD
- LAMPE TEMOIN SECURITE DE SURCHAUFFE
- L1** TERMOSTATO DI SOVRARISCALDAMENTO - OVE-
RHEAT SAFETY THERMOSTAT - ÜBERHITZUNG-
SCHUTZ THERMOSTAT - TERMOSTATO DE SOBRE-
TEMPERATURA - THERMOSTAT DE SECURITE DE
SURCHAUFFE
- L2** TERMOSTATO DI SICUREZZA A RIARMO MANUALE
- LIMIT THERMOSTAT WITH MANUAL RESTART - SI-
CHERHEITSTHERMOSTAT MIT MANUELLER ENTRIE
GELUNG- TERMOSTATO DE SEGURIDAD CON RESTA-
BLECIMIENTO MANUAL - THERMOSTAT DE SECURITE
A RIARMEMENT MANUEL

MODELLO - MODEL - MODELL - MODELO - MODELE	GREEN 70	GREEN 115	GREEN 200
Alimentazione elettrica - Power supply - Stromanschluß - Alimentación eléctrica - Alimentation électrique	230 V 50 Hz	230 V 400 V - 3 50 Hz	230 V 400 V - 3 50 Hz
Portata d'aria - Air output - Nenn-Luftleistung - Capacidad aire - Débit d'air	5.000 m ³	8.000 m ³	12.500 m ³
Consumo - Consumption - Brennstoffverbrauch - Consumo - Consommation	6,8 kg/h	11,3 kg/h	18,6 kg/h
Combustibile - Fuel - Brennstoff - Combustible - Combustible	Gasolio - Oil - Heizöl - Gasoil - Fuel		
Potenza termica max - Max. power - Max. Wärmeleistung - Potencia térmica máx. - Puissance thermique max.	81 kW	134 kW	220 kW
Rendimento - Efficiency - Wärmeleistung - Rendimiento - Rendement	87 %	89%	90 %
Temperatura dei fumi - Temperature of smokes - Rauchtemperatur - Temperature de los humos - Température des fumées	282 °C	220	200 °C
Potenza elettrica - Fan power consumption - Ventilatormotor Leistungsaufnahme - Potencia eléctrica del ventilador - Puissance électrique ventilateur	523 W	1.500 kW	2.820 kW
Potenza elettrica totale* - Total power consumption* - Leistungsaufnahme* - Potencia eléctrica total* - Puissance électrique*	728 W	1.690 W	2.850 W
Portata dei fumi* - Smokes flow* - Rauchdurchsatz* - Capacidad de los humos* - Débit des fumées	165 Nm ³ /h	223 Nm ³ /h	400 Nm ³ /h
Pressione statica disponibile - Available static pressure - Verfügbare Stat. Pressung Max. - Presión estática disponible - Pression statique disponible	10 mm H ₂ O	10 mm H ₂ O	10 mm H ₂ O
Contropressione in camera di combustione* - Burned gases pressure* - Rauchgaswiderstand* - Contrapresión en cámara de combustión* - Contre pression fumées*	1 mbar	1 mbar	1 mbar
Tiraggio minimo al camino* - Compulsory flue draft* - Erforderlicher Kaminzug* - Tiro mínimo a la chimenea* - Tirage minimum nécessaire*	0,1 mbar	0,1 mbar	0,1 mbar
Diametro uscita fumi - Flue diameter - Abgasrohr Durchmesser - Diámetro salida humos - Diamètre sortie fumées	150 mm	200 mm	200 mm
Sezione uscita aria - Air outlet section - Luftauslass querschnitt - Sección salida aire - Section sortie air	450 mm	60 mm	700 mm
Temperatura avviamento ventilatore - Fan starting temperature - Ventilatorthermostat - Temperatura puesta en marcha ventilador - Température démarrage ventilateur	35 °C	35 °C	35 °C
Temperatura limite di sicurezza - Safety limit temperature setting - Temperaturwächter - Temperatura límite de seguridad - Température limite de sécurité	85 °C	85 °C	85 °C
Livello sonoro a 1 m* - Noise level at 1 m* - Geräuschspegel a 1 m* - Nivel sonoro a 1 m* - Niveau sonore à 1 m*	72,5 dBA	79,6 dBA	81,3 dBA
Dimensioni, L x P x A - Dimensions, L x W x H - Masse, H x B x T - Dimensiones, L x P x A - Dimensions, L x P x H	137,5x92x672 cm	169,5x109x77,2 cm	218x140x80,4 cm
Peso - Weight - Gewicht - Peso - Poids	128 kg	195 kg	360 kg

*= Con bruciatore Ecoflam - Avec bruleur Ecoflam - Mit Ecoflam Brenner - With Ecoflam burner - Con quemador Ecoflam

MODELLO - MODEL - MODELL - MODELO - MODELE	GREEN 115			GREEN 200		
Alimentazione elettrica - Power supply - Stromanschluß - Alimentación eléctrica - Alimentation électrique	230 V 400 V - 3 50 Hz			230 V 400 V - 3 50 Hz		
Portata d'aria - Air output - Nenn-Lufleistung - Capacidad aire - Débit d'air	6.000 m ³			12.500 m ³		
Combustibile - Fuel - Brennstoff - Combustible - Combustible	G20	G30	G31	G20	G30	G31
Consumo - Consumption - Brennstoffverbrauch - Consumo - Consommation	10,5 Nm ³ /h	8,25 kg/h	8,13 kg/h	22,2 Nm ³ /h	17,42 kg/h	17,16 kg/h
Pressione gas - Gas pressure - Betriebsdruck - Presión gas - pression gaz	20 mbar	29 mbar	37 mbar	20 mbar	29 mbar	37 mbar
Potenza termica max* - Max. power* - Max. Wärmeleistung* - Potencia térmica máx.* - Puissance thermique max.*	134 kW			220 kW		
Rendimento - Efficiency - Wärmeleistung - Rendimiento - Rendement	88,5 %			89,7 %		
Temperatura dei fumi - Temperature of smokes - Rauchtemperatur - Temperature de los humos - Température des fumées	260			237 °C		
Potenza elettrica - Fan power consumption - Ventilatormotor Leistungsaufnahme - Potencia eléctrica del ventilador - Puissance électrique ventilateur	1.060 kW			2.820 kW		
Potenza elettrica totale* - Total power consumption* - Leistungsaufnahme* - Potencia eléctrica total* - Puissance électrique*	1.240 W			2.850 W		
Portata dei fumi* - Smokes flow* - Rauchdurchsatz* - Capacidad de los humos* - Débit des fumées	213 Nm ³ /h			446 Nm ³ /h		
Pressione statica disponibile - Available static pressure - Verfügbare Stat. Presung Max. - Presión estática disponible - Pression statique disponible	10 mm H ₂ O			10 mm H ₂ O		
Contropressione in camera di combustione* - Burned gases pressure* - Rauchgaswiderstand* - Contrapresión en cámara de combustión* - Contre pression fumées*	1 mbar			1 mbar		
Tiraggio minimo al camino* - Compulsory flue draft* - Erforderlicher Kaminzug* - Tiro mínimo a la chimenea* - Tirage minimum nécessaire*	0,1 mbar			0,1 mbar		
Diametro uscita fumi - Flue diameter - Abgasrohr Durchmesser - Diámetro salida humos - Diamètre sortie fumées	150 mm			200 mm		
Sezione uscita aria - Air outlet section - Luftauslass querschnitt - Sección salida aire - Section sortie air	500 mm			700 mm		
Temperatura avviamento ventilatore - Fan starting temperature - Ventilatorthermostat - Temperatura puesta en marcha ventilador - Température démarrage ventilateur	35 °C			35 °C		
Temperatura limite di sicurezza - Safety limit temperature setting - Temperaturwächter - Temperatura límite de seguridad - Température limite de sécurité	85 °C			85 °C		
Livello sonoro a 1 m* - Noise level at 1 m* - Geräuschspegel a 1 m* - Nivel sonoro a 1 m* - Niveau sonore à 1 m*	78,1 dBA			81,3 dBA		
Dimensioni, L x P x A* - Dimensions, L x W x H* - Masse, H x B x T* - Dimensiones, L x P x A* - Dimensions, L x P x H*	152x96x70,2 cm			218x140x80,4 cm		
Peso - Weight - Gewicht - Peso - Poids	160 kg			360 kg		

*= Con bruciatore Ecoflam - Avec bruleur Ecoflam - Mit Ecoflam Brenner - With Ecoflam burner - Con quemador Ecoflam