

Quick Setup

Before using the projector, make sure you read the safety instructions in the *User's Guide* on your projector CD.

Connect the projector

Choose from the following connections:

Computer Monitor Port

Connect a computer using the VGA cable that came with the projector.

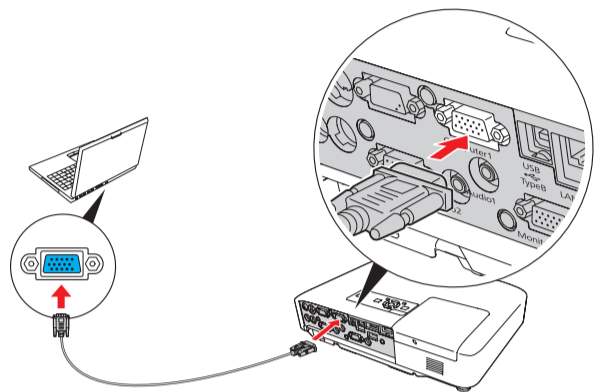

Connect one end to the projector's **Computer1** or **Computer2** port, and the other end to your computer's  monitor port. If you are using a notebook, switch it to external display. You can also connect an audio cable.

Computer USB Port

Connect a computer (Windows® 2000 or later only) using the USB cable that came with the projector.

Connect the square end of the USB cable to the projector's **USB TypeB** (square) port. Connect the flat end of the cable to any USB port on your computer.

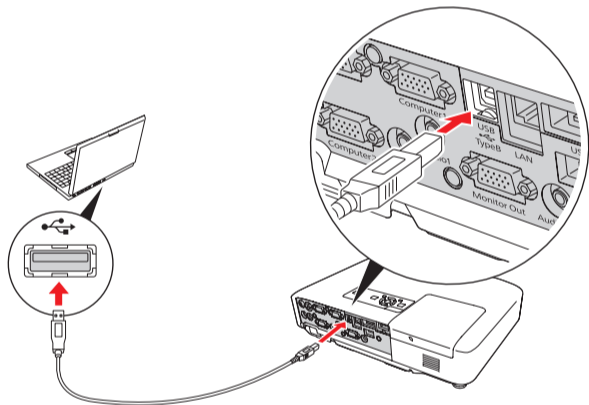

Follow the on-screen instructions to install the Epson USB Display software. (You need to install the software only the first time you connect.) Then press the **USB** button on the remote control.

Network (LAN)

Connect the projector to your network using an Ethernet® cable. See "Network Configuration" on the back of this sheet for more information.

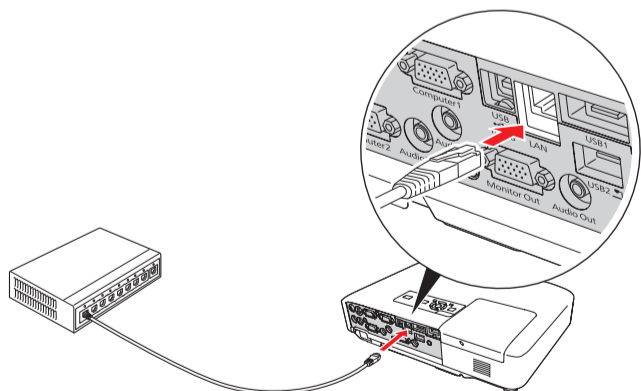

Video Player

Connect up to 4 video devices and use the remote control to switch between them.

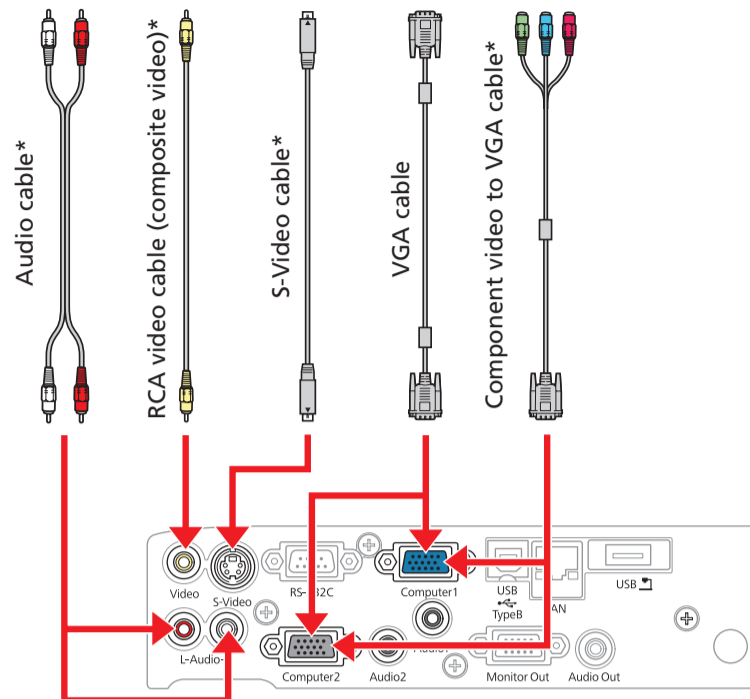

* These cables are optional.

Camera or USB Device

Connect a digital camera, Epson Document Camera, or other USB device to the projector's **USB Type A** (flat) port.

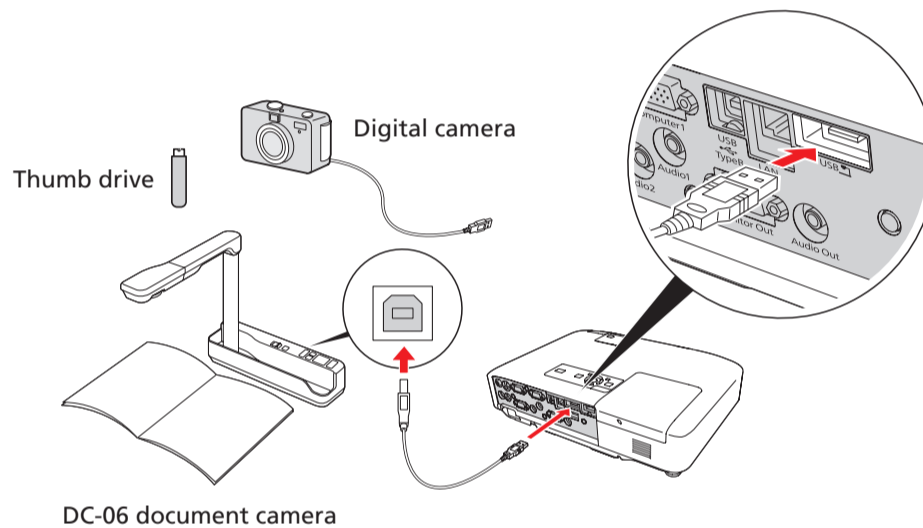

If you connect a digital camera or USB storage device, you can use the projector's Slideshow feature. See the *Network and PC Free Operation Guide* on your projector CD.

For information on connecting an external monitor or external speakers, see the *User's Guide* on your projector CD.

Turn on your equipment

- 1 Turn on your computer or video source.
- 2 Plug in the projector.

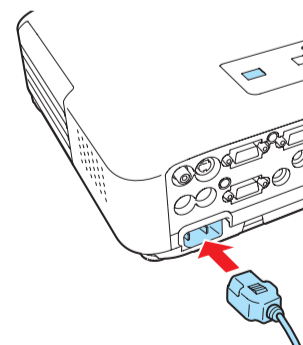

- 3** Open the **AV Mute** slide all the way.

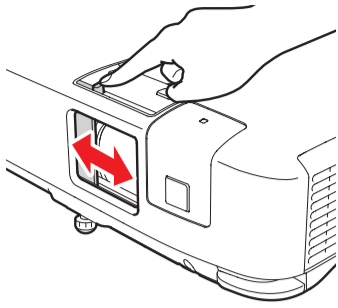

- 4** Press the  power button on the projector or remote control.

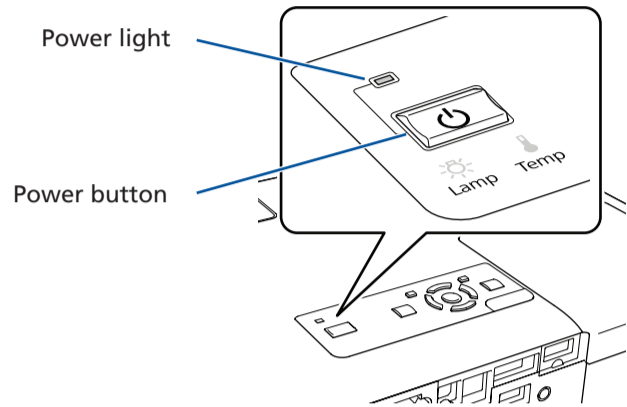

The power light flashes green, then stays on.

NOTE: To shut down the projector, press the  power button twice, then unplug it. You don't have to wait for the projector to cool down.

Adjust the image

- 1** If you don't see an image, press the **Source Search** button on the projector or the remote control to select the image source.

NOTE: If you still see a blank screen or have other display problems, see the troubleshooting tips on the back of this sheet.



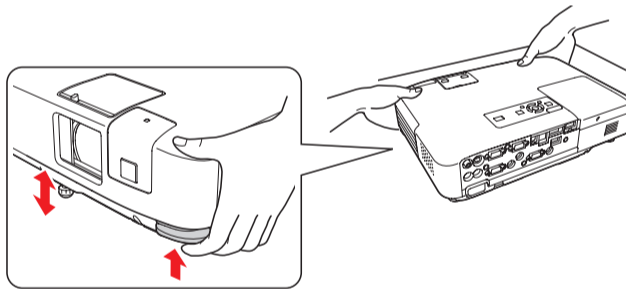



- 2** To raise the image, press the gray foot release lever and lift the front of the projector. Release the lever to lock the foot in position.

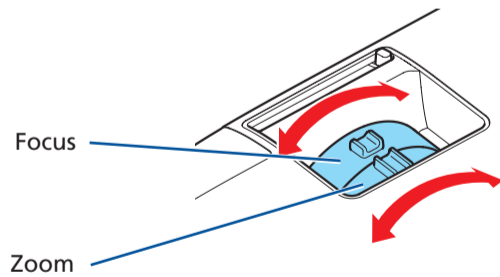

- 3** Turn the focus ring to sharpen the image.

Turn the zoom ring to reduce or enlarge the image.



- 4** If your image looks like  or , you've placed the projector off to one side of the screen at an angle. Place it directly in front of the center of the screen, facing the screen squarely.
- 5** If your image looks like  or , press the  or  buttons on the projector to correct it.

Using the remote control

Make sure the batteries are installed as shown (two AA batteries).

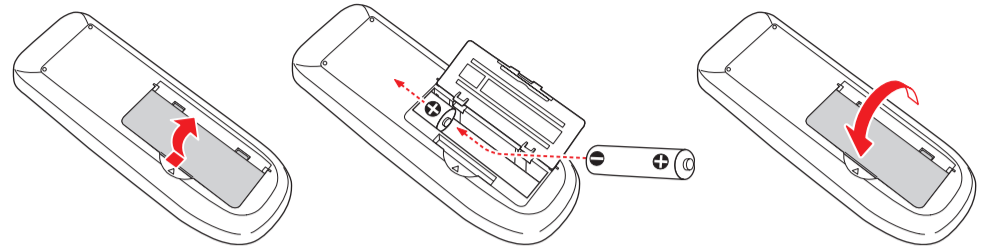

You can use the remote control to operate the projector. With the USB cable, you can use the remote as a wireless mouse. For more information on using the remote control, see your *User's Guide*.

Network configuration

If you need to configure the projector for your network, you can use the projector's menu system.

- 1 Press the **Menu** button on the remote control, select the **Network** menu, then press **Enter**.

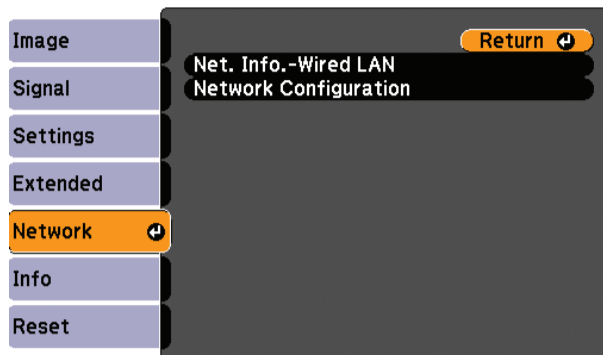

- 2 Choose **Network Configuration** and press **Enter**.
- 3 Select the **Wired LAN** menu and press **Enter**.
- 4 Choose **IP Settings** and press **Enter**. You see a screen like the following:

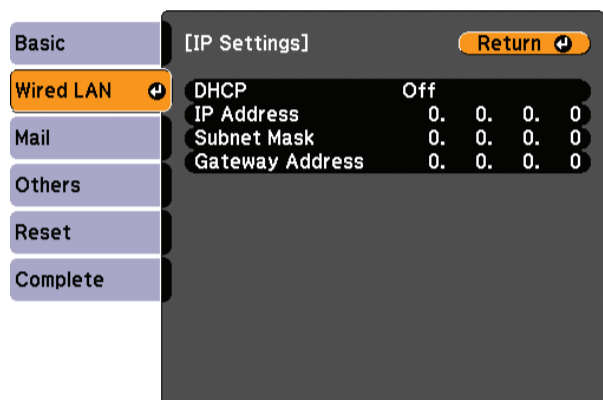

- 5 Do one of the following:
 - If your network assigns addresses automatically, turn on the **DHCP** setting.
 - If your network does not assign addresses automatically, turn off **DHCP** and enter the projector's **IP Address**, **Subnet Mask**, and **Gateway Address**, as needed.

To enter numbers, use the arrow buttons on the remote control to highlight a number, then press the **Enter** button. When you're finished entering an address, highlight **Return**, then press **Enter**.

- 6 To prevent the IP address from appearing on the network standby screen, set the **IP Address Display** setting to **Off**.
- 7 When you're done, select **Complete** and press **Enter** to save your settings. Then press **Enter** again to confirm.
- 8 Press the **Menu** button to exit the menu system.

Project over the network

Install EasyMP® Network Projection and Easy Management® EasyMP Monitor (Windows only) on each computer that will project over the network. Use the CD labeled **Epson Projector Software for Meeting & Monitoring** to install these programs.

- 1 Press the **LAN** button on the remote control.

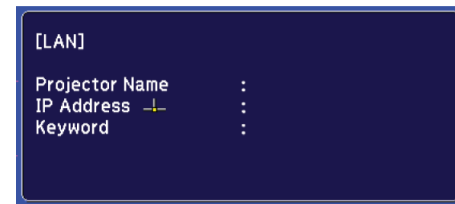

- 2 Start EasyMP Network Projection on your computer.
Windows: Select **Start > Programs** or **All Programs > EPSON Projector > EasyMP Network Projection**.

Mac OS® X: Double-click the **EasyMP Network Projection** icon in your Applications folder.

- 3 Select **Advanced Connection Mode**, then click **OK**.

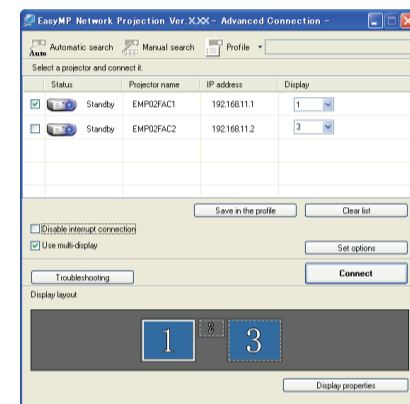

- 4 Select the projector you want to connect to, then click **Connect**.
If you don't see the projector you want, click the **Automatic search** button.
- 5 If you see a message asking for a keyword, enter the four digits that appear on the LAN standby screen and click **OK**.

Your computer image is projected, with a floating toolbar:



When you're done presenting, click **Disconnect** on the toolbar.

NOTE: For more information about using and monitoring the projector on a network, see your Network and PC Free Operation Guide and EasyMP Monitor Operation Guide (Windows only). These guides are installed along with your projector User's Guide and are viewable by clicking the icons for them on your computer desktop.

Troubleshooting

If you see a blank screen...

If you see a blank screen or the **No signal** message after turning on your computer, check the following:

- Make sure the power light on the projector is green and not flashing, and the **A/V Mute** slide is open.
- Press the **Source Search** button on the projector or the remote control to select the computer as the image source.
- If you're using a Windows notebook, press the function key on your keyboard that lets you display on an external monitor. It may be labelled **CRT/LCD** or have an icon such as . You may have to hold down the **Fn** key while pressing it.

If the projector and notebook don't display the same image...

Windows

Try using the CRT/LCD or  key as described above. On most systems, this key lets you toggle between the LCD screen and the projector, or display on both at the same time.

If that doesn't work, check your monitor settings to make sure both the LCD screen and the external monitor port are enabled.

- 1 From the Windows Control Panel, open the **Display** utility. In Windows Vista®, right-click on the desktop and select **Personalize**, then select **Display Settings**.
- 2 Click **Settings**, then click **Advanced** or **Advanced Settings**.

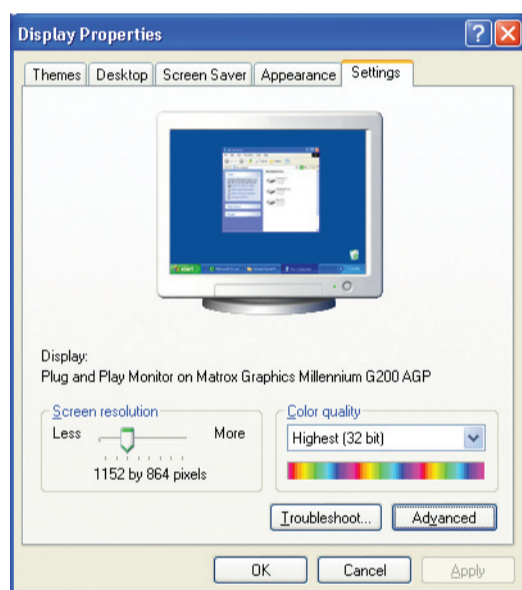

- 3 The method for adjusting the setting varies; you may have to click a **Monitor** tab, then make sure the external Monitor port is set as your primary display and/or enabled.

Mac OS X

- 1 From the Apple® menu, select **System Preferences**, then select **Display** or **Displays**.
- 2 Click **Detect Displays**.
- 3 Make sure the **VGA Display** or **Color LCD** dialog box is selected.
- 4 Click **Arrangement** or **Arrange**, then make sure **Mirror Displays** is selected.

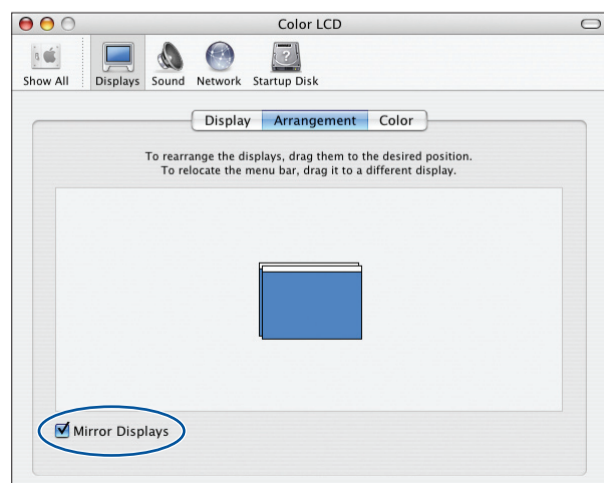

Where to get help

Manuals

For more information about using the projector, install the manuals from your projector CD.

Telephone Support Services

To use the Epson PrivateLine® Support service, call (800) 637-7661 and enter the PIN on the Epson PrivateLine Support card included with your projector. This service is available 6 AM to 6 PM, Pacific Time, Monday through Friday, for the duration of your warranty period. You may also speak with a projector support specialist by dialing:

(562) 276-4394 (U.S.) or (905) 709-3839 (Canada), 6 AM to 6 PM, Pacific Time, Monday through Friday

Days and hours of support are subject to change without notice. Toll or long distance charges may apply.

Internet Support

Visit epson.com/support for solutions to common problems. You can download utilities and documentation, get FAQs and troubleshooting advice, or e-mail Epson with your questions.

Registration

Register today to get product updates, special promotions, and customer-only offers. You can use the CD included with your projector or register online at www.epson.com/webreg.

Optional accessories

For a list of optional accessories, see your projector *User's Guide*.

You can purchase screens, carrying cases, or other accessories from an Epson authorized reseller. To find the nearest reseller, call 800-GO-EPSON (800-463-7766). Or you can purchase online at www.epsonstore.com (U.S. sales) or www.epson.ca (Canadian sales).

EPSON
EXCEED YOUR VISION



Epson, EasyMP, and Easy Management are registered trademarks, and Epson Exceed Your Vision is a registered logomark of Seiko Epson Corporation. PowerLite and PrivateLine are registered trademarks of Epson America, Inc.

General Notice: Other product names used herein are for identification purposes only and may be trademarks of their respective owners. Epson disclaims any and all rights in those marks.

This information is subject to change without notice.

© 2009 Epson America, Inc. 8/09
Printed in XXXXXX

CPD-27666