

## **GAS MONITORS**

**MODELS 2050-00 & 2050-10**  
**MODELS 2060-00 & 2060-10**

## **GAS MONITORS**

**MODELS 2050-00 & 2050-10  
MODELS 2060-00 & 2060-10**

### **APPLICABILITY & EFFECTIVITY**

This manual provides instructions for the following Sierra Monitor products:

<u>Model</u>	<u>Description</u>
2050-00	Ammonia Gas Monitor
2060-00	Halocarbon Gas Monitor

The instructions are effective for the above models as of January 1, 2004

---

## TABLE OF CONTENTS

<b><u>SECTION</u></b>	<b><u>PAGE</u></b>
<b>1. PRODUCT DESCRIPTION</b>	1
1.1 Introduction	1
1.2 Application	1
1.3 Configuration	1
1.4 Temperature Range	2
1.5 Sensor	2
1.6 Remote Alarm	2
<b>2. QUICK START</b>	3
2.1 Overview	3
2.2 Wiring	3
<b>3. OPERATION</b>	4
3.1 Introduction	4
3.2 Alarms	4
3.3 Outputs	4
<b>4. ALARM CALIBRATION</b>	5
4.1 Factory Alarm Calibration	5
4.2 Frequency of Alarm Calibration Check	5
4.3 Alarm Calibration Check Process	5
4.4 Equipment Required	6
4.5 Alarm Calibration Procedure	6
<b>5. SERVICE</b>	
5.1 Sensor Replacement	7
<b>6. INSTALLATION</b>	8
6.1 Gas Sensor Module Locations	8
6.2 Mounting	8
6.3 Wiring	8
6.4 Power Supply	8
6.5 Alarm Devices	8
<b>7. ALARM CONFIGURATION</b>	10
<b>8. SPECIFICATIONS</b>	11
<b>9. ACCESSORIES AND REPLACEMENT PARTS</b>	11
<b>10. LIMITED WARRANTY</b>	11

# Instruction Manual

## 1.0 PRODUCT DESCRIPTION

### 1.1 Introduction

The Model 2050 Ammonia and Model 2060 Refrigerant/Halocarbon Gas Monitors are continuous duty, low cost stationary monitors for detection of high levels (50-500 PPM) of ammonia and halocarbon ("freons") refrigerant gases. See the specifications page for a full list of available applicable halocarbons

This manual provides instructions for both the 2050 and 2060 series Gas Monitors, including the relay versions.

### 1.2 Application

These monitors are primarily used in and around freezers, refrigerators, and compressor rooms to warn of leaks and dangerous levels of these gases.

### 1.3 Configuration

An alarm is activated when the concentration of gas exceeds the user-adjustable level. An alarm condition activates the alarm light on the front of the monitor and generates an output signal. On Models 2050-00 and the 2060-00 the output signal a TTL (Transistor-Transistor-Logic signal) can activate a remote alarm through one of Sierra Monitor's Alarm Panels. (The Model 2102 Dual Channel Alarm Panel can be connected up to 500 feet from the monitors.) The models can be configured with a 0.5 amp, dry contact relay.

The monitors are housed in a polystyrene enclosure that is suitable for installation in freezer, refrigerator or other applications. Test connections and adjustment controls are located on the outside of the enclosure and are easily used, even when the operator is wearing hand protection.

The Model 2050 Ammonia monitor has a factory alarm setpoint of 100 ppm NH<sub>3</sub>. This setpoint is user adjustable in the field over a range of 50 to 500 ppm NH<sub>3</sub>. The Model 2050 calibration can be checked with Hydrogen gas.

The Model 2060 Halocarbon monitor can be calibrated with carbon monoxide and the factory setpoint varies for the specific type of halocarbon present. The

<u>Model</u>	<u>Gas</u>	<u>TTL</u>	<u>Relay</u>
2050-00	Ammonia	X	X
2060-00	Halocarbons	X	X

**Table 1.1 Gas Monitor Configurations**

factory setpoint for R12 is 500 ppm while the setpoint for R134 a is 50 ppm. See the specifications for more details.

The Model 2050 / 2060 is cross sensitive to other combustible gases. If combustible gasses in excess of 50 ppm are expected in the area please contact Sierra Monitor to determine amount of cross-sensitivity expected for the specific combustible gas. It is not recommended to use this unit in areas with combustible gases present.

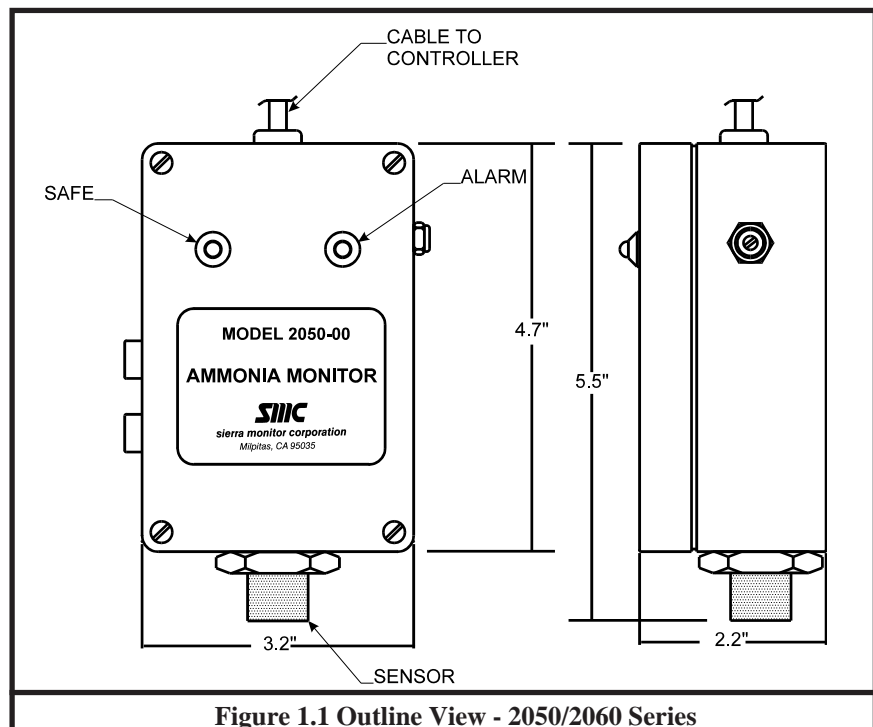

Figure 1.1 Outline View - 2050/2060 Series

#### **1.4 Temperature Range**

The Model 2050 and 2060 have temperature compensated circuitry to provide stabilization in temperatures ranging from -4° to 158°F.

However, for optimum operation the unit should be calibrated at the normal temperature expected for the sensor location.

#### **1.5 Semiconductor-Type Sensor**

A solid-state semiconductor-type sensor and associated electronic circuitry ensure trouble-free, long-term operation. All the electronic circuitry needed to operate the monitor, except the DC input power, is contained in a compact unit. There are no pumps, filters, or chemical cells to replace or maintain. Except for periodic calibration to verify the alarm setting, no attention is required after installation. The user may adjust the alarm level by applying a different calibration gas concentration.

A sensor self-check feature will flash the alarms on and off alternatively should the sensor fail (open circuit). The alarm flash includes LEDs, audible alarm, relay or alarm signal as applicable.

#### **1.6. Remote Alarm Available**

If a remote alarm is desired, Sierra Monitor's Alarm Panels, the Model 2102 Dual Channel Alarm Panels can be connected up to 500 feet away from the monitors.

## 2.0 QUICK START

### 2.1 Overview

The Gas Sensor Module has been supplied factory calibrated and ready for immediate installation and operation. An installer familiar with installation and operation of gas detection products can use this section to begin immediate use of the monitor.

### 2.2 Wiring

Each module requires four-conductor wiring (two wires for power and two wires for the signal).

#### 2.2.1. Model 2050-2060 Series

The Model 2050-2060 series are designed to mount on any indoor vertical surface. Mount the monitor in the desired location.

- **The installation must meet any hazardous environmental codes for AC/DC electrical instrumentation.**

#### 2.2.2 Wiring Connection

Terminal positions on the electronics board are as follows:

Terminal	Function
TB1-1	+ VDC (9 – 24)
TB1-2	GND (0VDC)
TB2-1	Relay NC (Normally Closed) or Output to Model 2102 Safe
TB2-2	Relay Common
TB2-3	Relay NO (Normally Open) or Output to Model 2102 Alarm

**Table 2.1**

#### 2.2.3 Start-up & Operation

To begin operation of the Gas Sensor Module provide 9 - 24 VDC from a regulated power supply such as one of the Sierra Monitor Alarm Panels, 2102-XX. Each time the sensor module is powered up it will perform a warm-up for 2 - 60 minutes.

During warm-up the monitor will, first, cycle through safe/alarm/safe condition at one hertz. This will be followed by a short period of continuous alarm before warm-up is completed.

#### 2.2.4 Configuration

The default configuration for each module is to operate with a buzzer and a normally operating open (NOO) relay. The user can change this configuration using the jumpers provided. Refer to table 6.2.

### 3.0 OPERATION

#### 3.1 Introduction

Under normal conditions the gas sensor module does not require operator or technician intervention. The following are conditions under which the module requires attention:

- **Routine periodic calibration**
- **Sensor replacement on a planned schedule or when a sensor failure occurs.**
- **Periodic cleaning as necessary.**

#### 3.2 Alarms

Three alarm conditions are possible. These can be detected visually at the optional Sierra Monitor controller and at the module.

##### Warm-Up Alarm

Oscillating (On/Off) contact closure and “red/green” visual indication when power is first connected to the module, followed by a continuous closure of approximately 2-60 minutes indicating warm-up.

Buzzer	Relay	Relay Fail Safe
On/Off	Oscilating	Oscilating

##### Gas Alarm

Sustained contact closure and solid red light (once the warm-up time is completed) indicating the presence of gas at, or above, the pre-set alarm limit.

Table 2.1

Buzzer	Relay	Relay Fail Safe
On	Closed	Open

#### Trouble Alarm

Interrupted contact closure and “red/green” visual indication (once the warm-up time is completed) after unit has been in operation, indicating either a failed sensor or calibration problems.

Buzzer	Relay	Relay Fail Safe
On/Off	Oscilating	Oscilating

#### 3.3 Outputs

For the non-relay configurations a 5 volt DC TTL signal is provided to activate remote alarms such as the Sierra Monitor Alarm Panels. Relay configuration alarm conditions described above are transmitted to the annunciator as relay contact closures from the monitor.

The alarm outputs are non-latching closed contacts. As soon as the gas concentration falls below the alarm set-point, the alarm will stop and the alarm output will cause the relay to de-energize and the contacts will open.

During warm-up and failed sensor alarms the relays contact and the display LED's oscillate at approximately one hertz.

**4.0 ALARM CALIBRATION**

**4.1 Factory Alarm Calibration**

The module has been factory calibrated to alarm as indicated in Table 4.1 and as marked on the calibration label shipped with the module.

<u>Model</u>	<u>Time</u>	<u>Gas</u>	<u>cc/min</u>
2050-XX	100 sec.	100 ppm NH <sub>3</sub>	50
2060-XX	60 sec.	500 ppm R11	50
		500 ppm R12	50
		50 ppm R22	50
		100 ppm R113	50
		70 ppm R123	50
		50 ppm R134a	50
		40 ppm R141b	50
		40 ppm R142b	50
		40 ppm R500	50
		70 ppm R502	50

**Table 4.1**

**4.2 Frequency of Alarm Calibration Check**

The manufacturer recommends that the calibration

of each gas sensor module be verified monthly during the first three months of operation and then quarterly. More frequent checks are necessary during periods of extreme humidity and temperature changes. The monitor should have operated continuously (uninterrupted) for at least 24 hours prior to calibration adjustment.

**4.3 Alarm Calibration Check Process**

The output signal of the gas sensor module is calibrated using a calibration gas mixture containing a known concentration of the gas of interest and a balance of air, or using a substitute gas. The concentration of the span gas must be equal to the alarm point desired.

The equivalent substitute gas is 80 ppm Hydrogen (H<sub>2</sub>) for the Model 2050 and 150 ppm Carbon Monoxide (CO) for the Model 2060.

Calibration requires application of the span gas to the sensor and adjustment of the sensitivity adjustment potentiometer.

**Warning:** During calibration the alarm will turn on and remote alarms connected to the alarm relays will be activated. Disable the remote alarm if necessary.

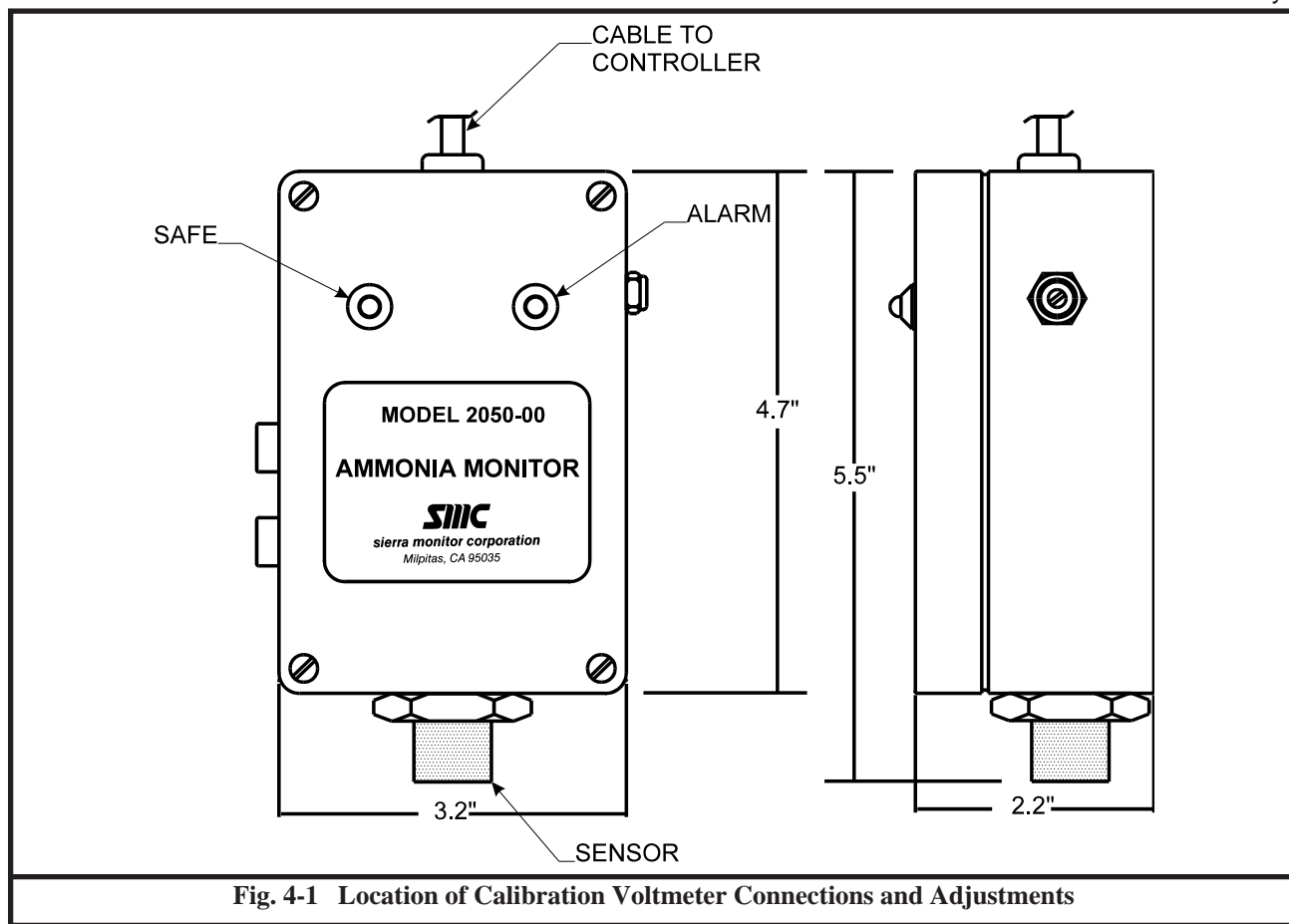

**Fig. 4-1 Location of Calibration Voltmeter Connections and Adjustments**



#### 4.4 Equipment Required

The following tools and equipment will be required for calibration:

- Jewelers Screwdriver
- Calibration Gas
- Calibration gas delivery system

For accurate calibration use a gas mixture at the required concentration mixed in an air balance, rather than with an inert gas like nitrogen. This gas and the required delivery equipment such as the Model 1200-26 Calibrator is available from Sierra Monitor Corporation.

#### 4.5 Alarm Calibration Procedure

1. The monitor should be in the safe condition prior to calibration (green LED "ON").
  - **Be sure that the area is non-hazardous before proceeding.**
2. With the monitor in operation, expose the sensor to a sample of calibration gas. Apply calibration gas directly to the sensor insuring that the delivery cup loosely covers the sensor. Use 80 PPM H<sub>2</sub> for the Model 2050 and 150 PPM CO for the Model 2060.
3. The red LED on the face of the monitor should turn "on". If the alarm occurs within 18-20 seconds and stops within one minute of the removal of the calibration gas, the monitor is in calibration and requires no further adjustment.
4. If the monitor fails to alarm within 90 seconds of the application of the gas adjust the potentiometer counter clockwise until the alarm turns "on".
5. If the monitor fails to stop alarming within one minute of the removal of the gas adjust the potentiometer clockwise until the alarm stops.
6. After adjustment, repeat steps 4 and 5 to verify calibration.
7. When the calibration is complete, reconnect any alarm equipment as necessary.

## 5.0 SERVICE

### 5.1 Sensor Replacement

The gas sensor needs replacement when:

- It is no longer possible to obtain correct calibration
- The failed sensor alarm (oscillating red/green LED) is on
- The sensor output signal is noisy, causing incorrect gas alarms.

To replace the sensor:

1. Confirm that the system power has been removed.

2. Remove the cover from the main enclosure.
3. Unplug the sensor connector on the lower right hand corner of the electronics board.
4. Unscrew the sensor assembly from the end of the enclosure.
5. Reverse the preceding steps to install the new sensor assembly.
6. Restore power and allow a minimum of 24 hours for stabilization before recalibration. The calibration should be re-verified after 6 days of continuous operation.

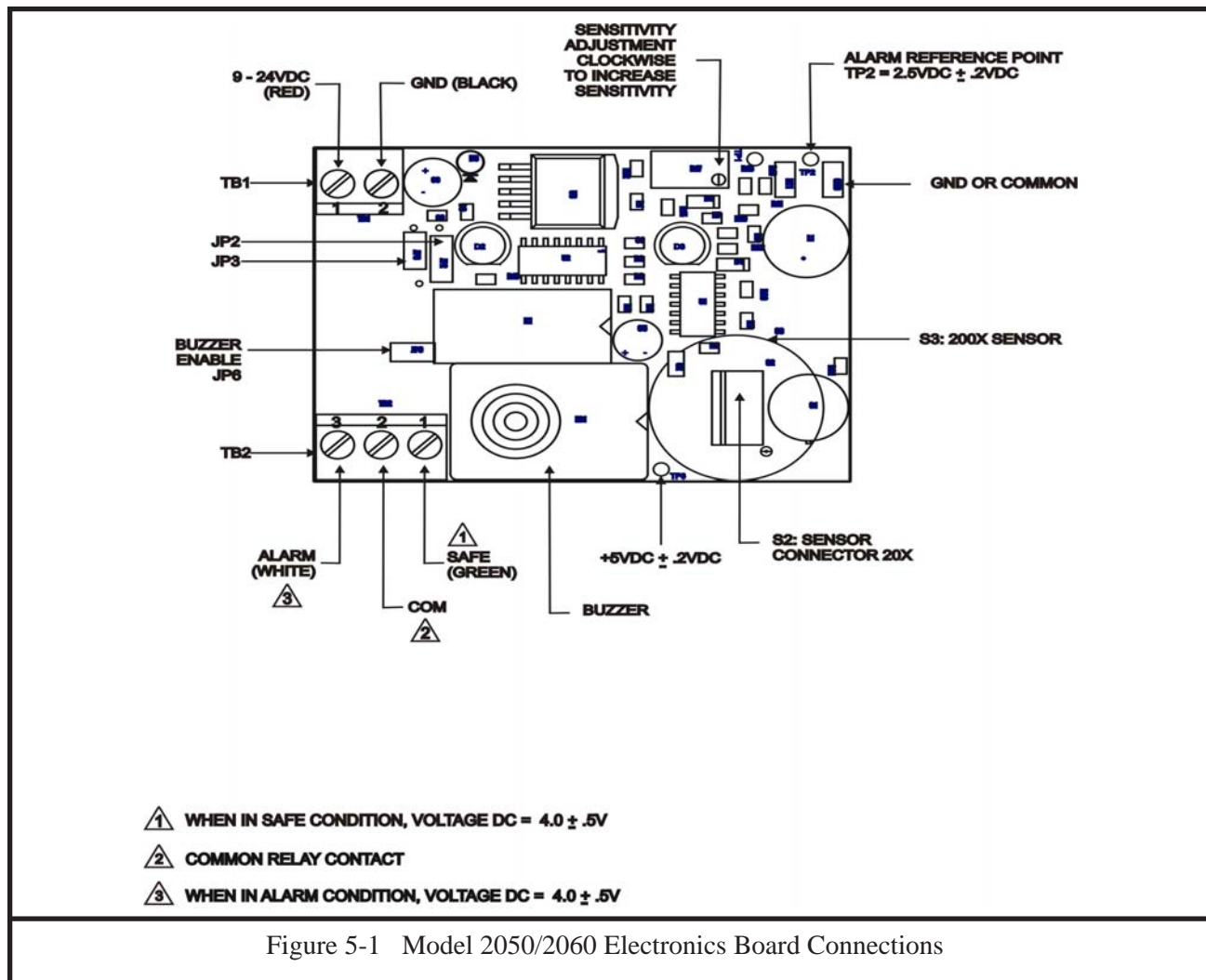

## 6.0 INSTALLATION

### 6.1 Gas Sensor Module Locations

The gas sensor module is a diffusion type sensor that should be located close to the anticipated source or destination of the gas hazard. For heavy gases such as H<sub>2</sub>S install the module within 24 inches of the ground. For lighter gases such as CO and combustible gases use a higher elevation.

After optimum locations are determined based on the above recommendations, consideration should be given to placing the sensors in locations that are accessible for calibration service. Slight adjustments to the location of the sensor may have little impact on effectivity but major effect on accessibility.

### 6.2 Mounting

To mount the monitor, remove the four screws in the cover plate and move the cover plate aside. Use screws through the monitoring holes visible in the four corners of the housing to mount the monitor to a wall.

- The installation must meet any hazardous environmental codes for AC/DC electrical instrumentation.

### 6.3 Wiring

Interconnect wiring from the controller to the module is by 4 conductor 22 AWG (or lower AWG) cable, conduit as necessary. Shielding is not required. For installations where the distance from the controller to the sensor is greater than 500 feet, 18 AWG cable is recommended.

### 6.4 Power Supply

The power supplied by the controlling device or an external power supply must meet the following specifications:

Voltage: 9 - 24 VDC  
Current: 250 mA

### 6.5 Alarm Devices

The internal relay is rated at 0.5 Amp, normally open dry contact rated at 100 VDC/130 VAC.

Terminal	Function
TB1-1	+ VDC (9 – 24)
TB1-2	GND (0VDC)
TB2-1	Relay NC (Normally Closed) or Output to Model 2102 Safe
TB2-2	Relay Common
TB2-3	Relay NO (Normally Open) or Output to Model 2102 Alarm
<b>Table 6.1</b>	

The terminal strip on the electronics board in the module. The wiring must be connected as indicated in Figure 6.1 depending upon the controller or relay configuration being used.

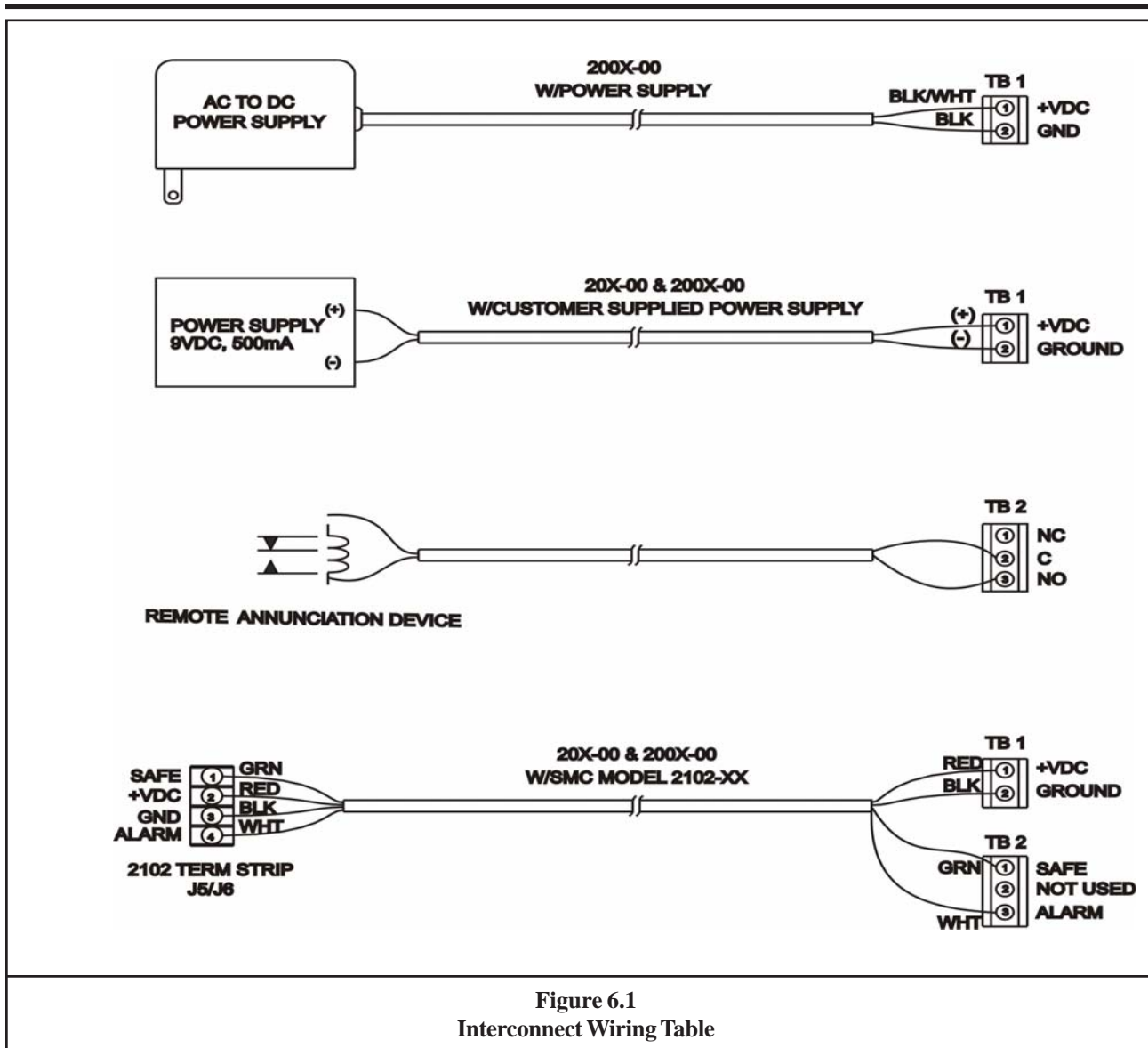

Figure 6.1  
Interconnect Wiring Table

7.0 ALARM CONFIGURATION

Model 20X or 200X Configured with Alarm Relay Output				
Configuration Jumpers				
Buzzer Active		Relay Operation		
Yes	No	Normally Not Energized		Normally Energized
Default		Default		
Install Jumper JP6	Remove Jumper JP6 (Best for 20X)	Install Jumper JP2 pins 1-2		Install Jumper JP2 pins 2-3
Wiring Terminations				
Power Supply		Output Terminals		
TB1-1	TB1-2	TB2-1	TB2-2	TB2-3
+ DCV (9-24 VDC)	0 DC Common	NC	Common	NO
Model 20X or 200X Configured for Interface to Model 2102 Alarm Panel				
Configuration Jumpers				
Buzzer Active		Relay Operation		Interface Selection
Yes	No	Normally Not Energized	Normally Energized	Model 2102
Default		Default		
Install Jumper JP6	Remove Jumper JP6 (Best for 20X)	N/A	N/A	Install Jumpers JP3 pins 1-2 JP2 pins 1-2
Wiring Terminations				
Power Supply		Output Terminals		
TB1-1	TB1-2	TB2-1	TB2-3	TB2-2
+ DCV To Model 2102 Terminal J5 -2 or J6-2	0 DC To Model 2102 Terminal J5 -3 or J6-3	Safe To Model 2102 Terminal J5 -1 or J6-1	Alarm To Model 2102 Terminal J5 -4 or J6-4	Not Used

**Table 6.2**  
**Jumper Configuration and Wiring Terminations**

Relay Operation			
Normally Not Energized			
	TB2-1 NC	TB2-2 Common	TB2-3 NO
No Power	Connected		Open
Sensor Fail	Oscillating		
Safe	Connected		Open
Alarm	Open	Connected	
Normally Energized - Fail Safe			
	TB2-1 NC	TB2-2 Common	TB2-3 NO
No Power	Connected		Open
Sensor Fail	Oscillating		
Safe	Open	Connected	
Alarm	Connected		Open

**Table 6.3**  
**Relay Operating States**

## 8.0 SPECIFICATIONS

Indicators:	Green LED for Monitor "ON"/Safe Red LED for Alarm	Calibration Gas:	2050 Series 80 ppm Hydrogen (H <sub>2</sub> ) 2060 Series 150 ppm Carbon Monoxide (CO)
Sensor Type:	Solid-state metal oxide semiconductor	Power:	9 VDC, 250 mA
Alarm Setpoint::		Signal Output::	
2050 Series	100 ppm NH <sub>3</sub>	2050-00/2060-00	Nominal 5 volt DC, source 25 mA. SAFE and ALARM Signals
2060 Series	R11 500 ppm R12 500 ppm R22 50 ppm R113 100 ppm R123 70 ppm R134a 50 ppm R141b 40 ppm R142b 40 ppm R500 40 ppm R502 70 ppm		0.5 AMP dry contact, 100 VDC, 130 VAC
	User adjustable with calibration over range of 50 to 500 ppm	Response Time:	Less than 90 seconds
		Operating Temperature Range:	-4° to 158°F (-20° to 70°C)
		Enclosure Material:	Polystyrene
		Size:	5.6 x 3.1 x 2.1 in. (14.2 x 7.9 x 5.3 cm)
		Weight:	0.3 lb (0.15 Kg)

---

## 9.0 ACCESSORIES AND REPLACEMENT PARTS

### Alarm Panels

Model 2102-00	Alarm Panel - 2 channel
Model 2102-01	Alarm Panel - 2 channel with audible

### Replacement parts

SPF22073	Sensor for 2050-XX
SPF22074	Sensor for 2060-XX

### Calibration Accessories

1200-26	Gas Sensor Calibrator w/2 gas cylinders (specify gas type/conc)
1290-10	Gas Cylinder - Carbon Monoxide 150 PPM
1290-11	Gas Cylinder - Hydrogen 80 PPM

---

## 10.0 LIMITED WARRANTY

SIERRA MONITOR CORPORATION warrants its products to be free from defects in workmanship or material under normal use and service for two year after date of shipment. SMC will repair or replace without charge any equipment found to be defective during the warranty period. Final determination of the nature and responsibility for defective or damaged equipment will be made by SMC personnel.

All warranties hereunder are contingent upon proper use in the application for which the product was intended and do not cover products which have been modified or repaired without SMC approval or which have been subjected to accident, improper maintenance, installation or application, or on which original identification marks have been removed or altered. This Limited Warranty also will not apply to interconnecting cables or wires, consumables (ie. calibration gases, batteries), nor to any damage resulting from battery leakage.

In all cases SMC's responsibility and liability under this warranty shall be limited to the cost of the equipment. The purchaser must obtain shipping instructions for the prepaid return of any item under this warranty provision and compliance with such instruction shall be a condition of this warranty.

Except for the express warranty stated above, SMC disclaims all warranties with regard to the products sold hereunder including all implied warranties of merchantability and fitness and the express warranties stated herein are in lieu of all obligations or liabilities on the part of SMC for damages including but not limited to consequential damages arising out of/or in connection with the use or performance of the product.