



# MICROWAVE OVEN

G2711N

# SERVICE *Manual*

## MICROWAVE OVEN

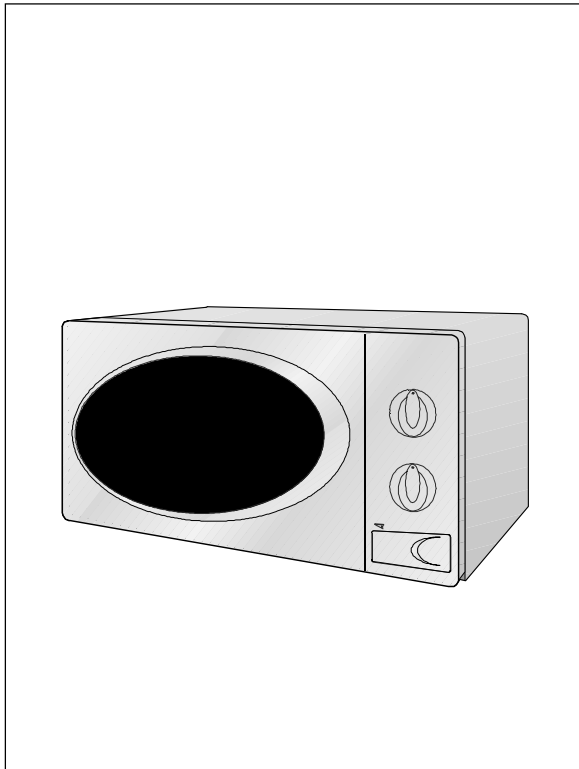

NEC

## CONTENTS

- 1. Precaution
- 2. Specifications
- 3. Operating Instructions
- 4. Disassembly and Reassembly
- 5. Alignment and Adjustments
- 6. Troubleshooting
- 7. Exploded Views and Parts List
- 8. Schematic Diagrams

## **PRECAUTIONS TO BE OBSERVED BEFORE AND DURING SERVICING TO AVOID POSSIBLE EXPOSURE TO EXCESSIVE MICROWAVE ENERGY**

- (a) Do not operate or allow the oven to be operated with the door open.
  - (b) Make the following safety checks on all ovens to be serviced before activating the magnetron or other microwave source, and make repairs as necessary:
    - (1) Interlock operation,
    - (2) proper door closing,
    - (3) seal and sealing surfaces (arcing, wear, and other damage),
    - (4) damage to or loosening of hinges and latches,
    - (5) evidence of dropping or abuse.
  - (c) Before turning on microwave power for any service test or inspection within the microwave generating compartments, check the magnetron, wave guide or transmission line, and cavity for proper alignment, integrity, and connections.
  - (d) Any defective or misadjusted components in the interlock, monitor, door seal, and microwave generation and transmission systems shall be repaired, replaced, or adjusted by procedures described in this manual before the oven is released to the owner.
  - (e) A Microwave leakage check to verify compliance with the Federal performance standard should be performed on each oven prior to release to the owner.
-

---

# 1. Precaution

---

Follow these special safety precautions. Although the microwave oven is completely safe during ordinary use, repair work can be extremely hazardous due to possible exposure to microwave radiation, as well as potentially lethal high voltages and currents.

## 1-1 Safety precautions (⚠)

---

1. All repairs should be done in accordance with the procedures described in this manual. This product complies with Federal Performance Standard 21 CFR. Subchapter J(DHHS).
2. Microwave emission check should be performed to prior to servicing if the oven is operative.
3. If the oven operates with the door open :  
Instruct the user not to operate the oven and contact the manufacturer and the center for devices and radiological health immediately.
4. Notify the Central Service Center if the microwave leakage exceeds 5 mW/cm<sup>2</sup>.
5. Check all grounds.
6. Do not power the MWO from a "2-prong" AC cord. Be sure that all of the built-in protective devices are replaced. Restore any missing protective shields.
7. When reinstalling the chassis and its assemblies, be sure to restore all protective devices, including: nonmetallic control knobs and compartment covers.
8. Make sure that there are no cabinet openings through which people --particularly children --might insert objects and contact dangerous voltages. Examples: Lamp hole, ventilation slots.
9. Inform the manufacturer of any oven found to have emission in excess of 5 mW/cm<sup>2</sup> ,  
Make repairs to bring the unit into compliance at no cost to owner and try to determine cause.  
Instruct owner not to use oven until it has been brought into compliance.
10. Service technicians should remove their watches while repairing an MWO.
11. To avoid any possible radiation hazard, replace parts in accordance with the wiring diagram. Also, use only the exact replacements for the following parts:  
Primary and secondary interlock switches, interlock monitor switch.
12. If the fuse is blown by the Interlock Monitor Switch: Replace all of the following at the same time: Primary, door sensing switch and power relay, as well as the Interlock Monitor Switch. The correct adjustment of these switches is described elsewhere in this manual. Make sure that the fuse has the correct rating for the particular model being repaired.
13. Design Alteration Warning:  
Use exact replacement parts only, i.e., only those that are specified in the drawings and parts lists of this manual. This is especially important for the Interlock switches, described above. Never alter or add to the mechanical or electrical design of the MWO. Any design changes or additions will void the manufacturer's warranty. Always unplug the unit's AC power cord from the AC power source before attempting to remove or reinstall any component or assembly.
14. Never defeat any of the B+ voltage interlocks. Do not apply AC power to the unit (or any of its assemblies) unless all solid-state heat sinks are correctly installed.
15. Some semiconductor ("solid state") devices are easily damaged by static electricity. Such components are called Electrostatically Sensitive Devices (ESDs). Examples include integrated circuits and field-effect transistors.  
Immediately before handling any semiconductor components or assemblies, drain the electrostatic charge from your body by touching a known earth ground.
16. Always connect a test instrument's ground lead to the instrument chassis ground *before* connecting the positive lead; always remove the instrument's ground lead last.

### CENTRAL SERVICE CENTER

10. Service technicians should remove their watches while repairing an MWO.

## 1-2 Special Servicing Precautions (Continued)

- When checking the continuity of the switches or transformer, always make sure that the power is OFF, and one of the lead wires is disconnected.
- Components that are critical for safety are indicated in the circuit diagram by shading, ⚠ or ⚡.
- Use replacement components that have the same ratings, especially for flame resistance and dielectric strength specifications. A replacement part that does not have the same safety characteristics as the original might create shock, fire or other hazards.

## 1-3 Special High Voltage Precautions

- High Voltage Warning**  
Do not attempt to measure any of the high voltages --this includes the filament voltage of the magnetron. High voltage is present during any cook cycle.  
Before touching any components or wiring, always unplug the oven and discharge the high voltage capacitor (See Figure 1-1)
- The high-voltage capacitor remains charged about 30 seconds after disconnection. Short the negative terminal of the high-voltage capacitor to the oven chassis. (Use a screwdriver.)
- High voltage is maintained within specified limits by close-tolerance, safety-related components and adjustments. If the high voltage exceeds the specified limits, check each of the special components.

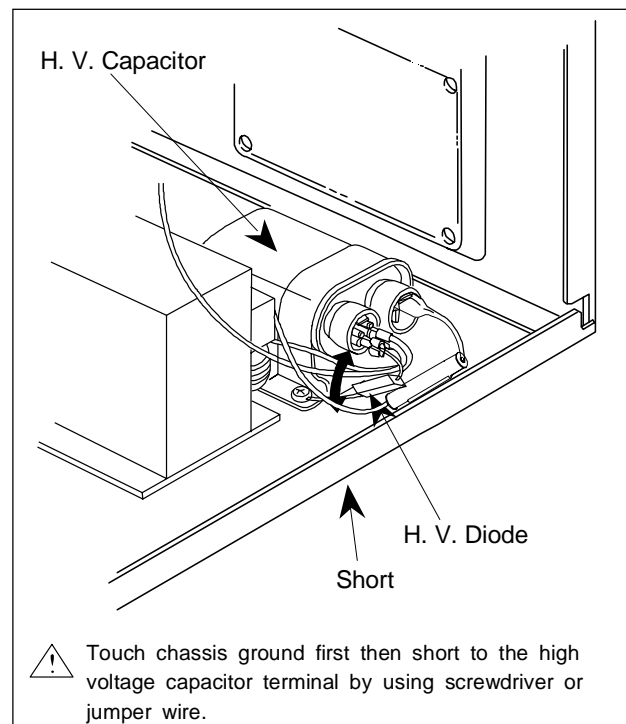

Fig. 1-1 Discharging High Voltage Capacitor

### PRECAUTION

There exists HIGH VOLTAGE ELECTRICITY with high current capabilities in the circuits of the HIGH VOLTAGE TRANSFORMER secondary and filament terminals. It is extremely dangerous to work on or near these circuits with the oven energized.  
DO NOT measure the voltage in the high voltage circuit including filament voltage of magnetron.

### PRECAUTION

Never touch any circuit wiring with your hand nor with uninsulated tool during operation.

### PRECAUTION

Servicemen should remove their watches whenever working close to or replacing the magnetron.

---

## 2. Specifications

---

### 2-1 Table of Specifications

---

TIMER	35 MINUTES
POWER SOURCE	230V ~50Hz
POWER CONSUMPTION	
MICROWAVE	1100W
Grill	1000W
Combined mode	2100W
OUTPUT POWER	100W/750W (IEC-705)
OPERATING FREQUENCY	2,450MHz
MAGNETRON	OM75S(31)
COOLING METHOD	COOLING FAN MOTOR
OUTSIDE DIMENSIONS	489(W) x 275(H) x 392(D)
OVEN DIMENSIONS	330(W) x 187(H) x 320(D)
SHIPPING DIMENSIONS	557(W) x 329(H) x 451(D)
SHIPPING WEIGHT APPROX.	NET      15 kg GROSS    15.0kg

# 3. Operating Instructions

## 3-1 Control Panel

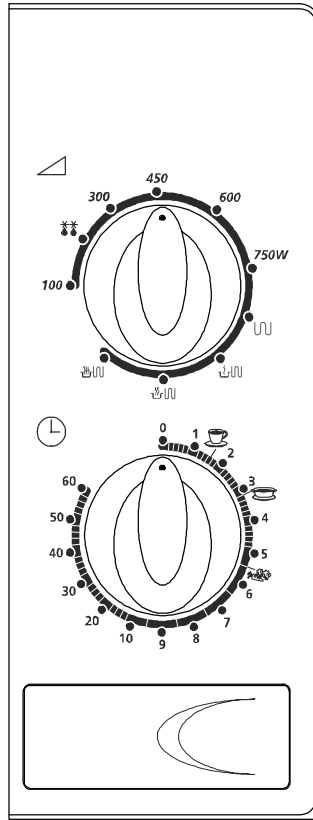

## 3-2 Features & External Views

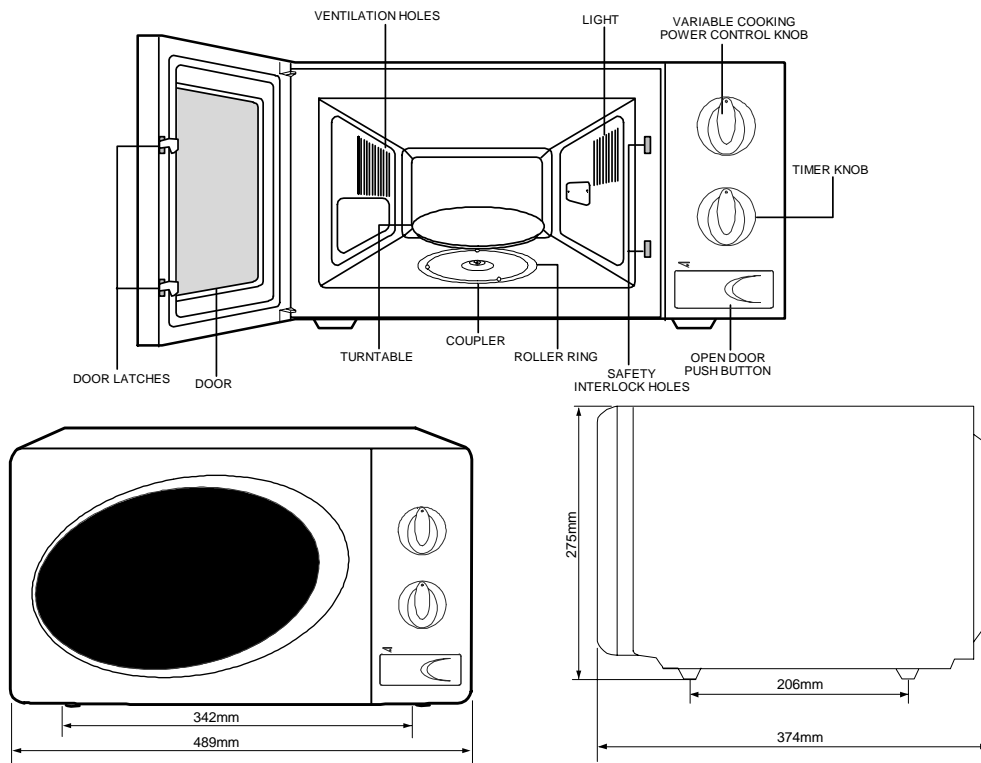

---

## 4. Disassembly and Reassembly

---

### 4-1 Replacement of Magnetron, Motor Assembly and Lamp

---

Remove the magnetron including the shield case, permanent magnet, choke coils and capacitors (all of which are contained in one assembly).

1. Disconnect all lead wires from the magnetron and lamp.
2. Remove a screw securing air cover.
3. Remove the air cover.
4. Remove screws securing the magnetron to the wave guide.
5. Take out the magnetron very carefully.
6. Remove nuts from the back panel.
7. Take out the fan motor.
8. Remove the oven lamp by rotating to pull out from hole of air cover.

NOTE1: When removing the magnetron, make sure that its antenna does not hit any adjacent parts, or it may be damaged.

NOTE2: When replacing the magnetron, be sure to remount the magnetron gasket in the correct position and make sure the gasket is in good condition.

### 4-2 Replacement of High Voltage Transformer

---

1. Discharge the high voltage capacitor.
2. Disconnect all the leads.
3. Remove the mounting bolts.
4. Reconnect the leads correctly and firmly.

**PRECAUTION**

Servicemen should remove their watches whenever working close to or replacing the magnetron.

**PRECAUTION**

There exists HIGH VOLTAGE ELECTRICITY with high current capabilities in the circuits of the HIGH VOLTAGE TRANSFORMER secondary and filament terminals. It is extremely dangerous to work on or near these circuits with the oven energized.  
DO NOT measure the voltage in the high voltage circuit including filament voltage of magnetron.

---

## 4-3 Replacement of Door Assembly

---

### 4-3-1 Removal of Door "C"

Insert flat screwdriver into the gap between Door "A" and Door "C" to remove Door "C". Be careful when handling Door "C" because it is fragile. Then remove the door assembly.

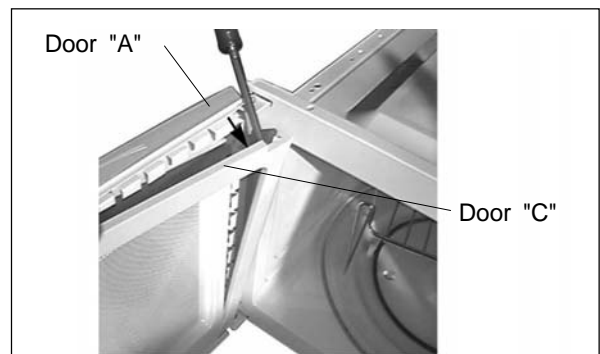

### 4-3-2 Removal of Door "E"

Following the procedure as shown in the figure, insert and bend a thin metal plate between Door "E" and Door "A" until you hear the 'tick' sound.

1. Insertion depth of the thin metal plate should be 0.5mm or less.

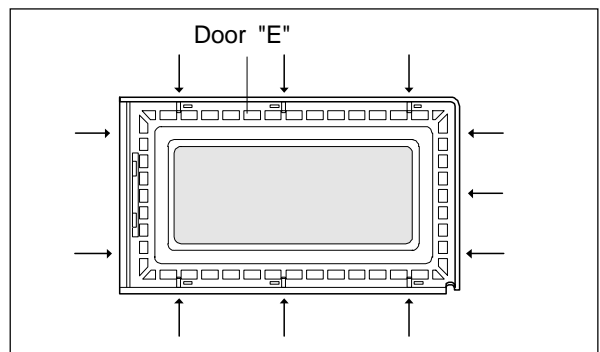

### 4-3-3 Removal of Key Door & Spring

Remove pin hinge from Door "E"  
Detach spring from Door "E" and key door.

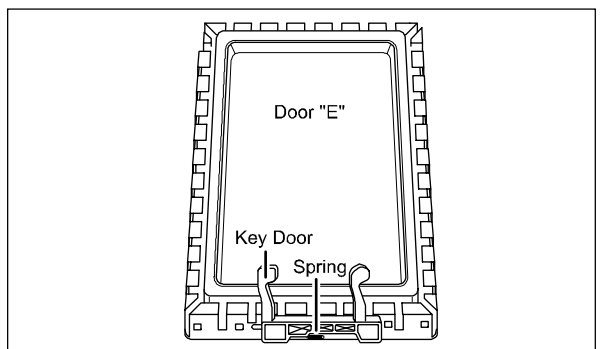



---

## 4-3-4 Reassembly Test

---

After replacement of the defective component parts of the door, reassemble it and follow the instructions below for proper installation and adjustment so as to prevent an excessive microwave leakage.

1. When mounting the door to the oven, be sure to adjust the door parallel to the bottom line of the oven face plate by moving the upper hinge and lower hinge in the direction necessary for proper alignment.
2. Adjust so that the door has no play between the inner door surface and oven front surface. If the door assembly is not mounted properly, microwave energy may leak from the space between the door and oven.
3. Do the microwave leakage test.

---

## 4-4 Replacement of Fuse

---

1. Disconnect the oven from the power source.
2. When 12A fuse blows out by the operation of interlock monitor switch failure, replace the primary interlock switch, door sensing switch, monitor switch and power relay.
3. When the above three switches operate properly, check if any other part such as the control circuit board, blower motor or high voltage transformer is defective.

---

## 4-5 Replacement of Drive Motor

---

1. Take out the glass tray, guide roller and coupler from cavity.
2. Turn the oven upside down to replace the drive motor.
3. Remove a screw securing the drive motor cover.
4. Disconnect all the lead wires from the drive motor.
5. Remove screws securing the drive motor to the cavity.
6. Remove the drive motor.
7. When replacing the drive motor, be sure to remount it in the correct position.
8. Connect all the leads to the drive motor.
9. Screw the drive motor cover to the base plate with a screw driver.
10. Remount the coupler in the correct position.

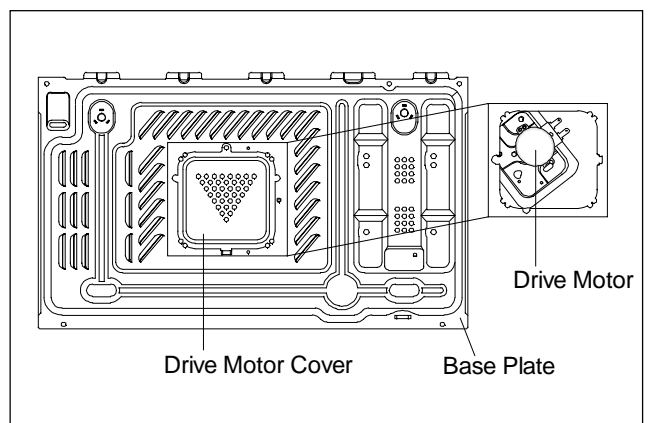

---

## 4-6 Replacement of Control Circuit Board

---

### 4-6-1 Removal of Control Box Assembly

1. Disconnect the connectors from the control box assembly.
2. Remove screws securing the control box assembly.
3. Remove the knobs of the control box A'ssy.
4. Remove the screw securing the timer.

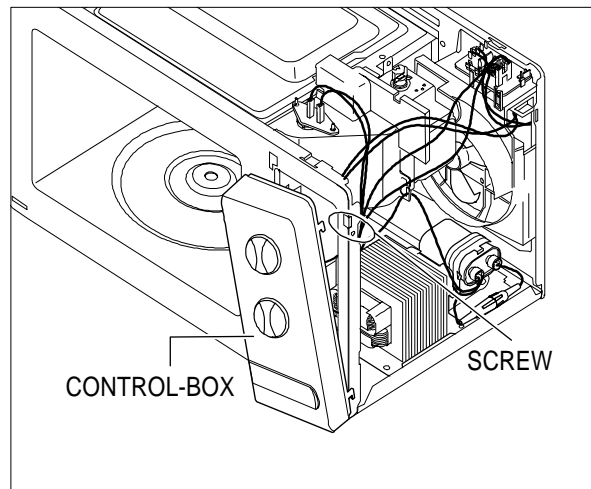

---

## 5. Alignment and Adjustments

---

### PRECAUTION

1. High voltage is present at the high voltage terminals during any cook cycle.
2. It is neither necessary nor advisable to attempt measurement of the high voltage.
3. Before touching any oven components or wiring, always unplug the oven from its power source and discharge the high voltage capacitor.

### 5-1 High Voltage Transformer

---

1. Remove connectors from the transformer terminals and check continuity.
2. Normal resistance readings are as follows:

Secondary	Approx. 151.5 $\Omega$
Filament	Approx. 0 $\Omega$
Primary	Approx. 2.5 $\Omega$

(Room temperature = 20°C)

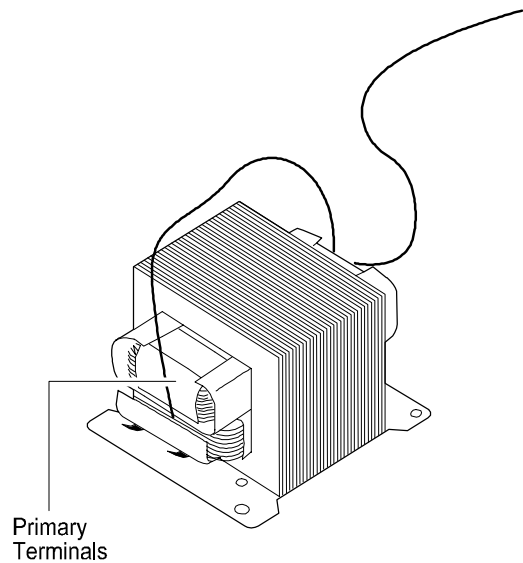

### 5-2 Magnetron

---

1. Continuity checks can indicate only an open filament or a shorted magnetron. To diagnose an open filament or shorted magnetron :
2. Isolate the magnetron from the circuit by disconnecting its leads.
3. A continuity check across the magnetron filament terminals should indicate one ohm or less.
4. A continuity check between each filament terminal and magnetron case should read open.

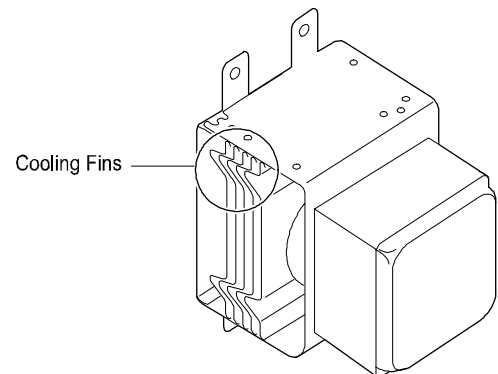

## 5-3 High Voltage Capacitor

1. Check continuity of the capacitor with the meter set at the highest resistance scale.
2. Once the capacitor is charged, a normal capacitor shows continuity for a short time, and then indicates  $9M\Omega$ .
3. A shorted capacitor will show continuous continuity.
4. An open capacitor will show constant  $9M\Omega$ .
5. Resistance between each terminal and chassis should read infinite.

## 5-4 High Voltage Diode

1. Isolate the diode from the circuit by disconnecting its leads.
2. With the ohm-meter set at the highest resistance scale, measure across the diode terminals. Reverse the meter leads and read the resistance. A meter with 6V, 9V or higher voltage batteries should be used to check the front-to back resistance of the diode (otherwise an infinite resistance may be read in both directions). The resistance of a normal diode will be infinite in one direction and several hundred  $K\Omega$  in the other direction.

## 5-5 Adjustment of Primary Switch, Door Sensing Switch and Monitor Switch

### Precaution

For continued protection against radiation hazard, replace parts in accordance with the wiring diagram and be sure to use the correct part number for the following switches: Primary and secondary interlock switches, and the interlock monitor switch (replace all together). Then follow the adjustment procedures below. After repair and adjustment, be sure to check the continuity of all interlock switches and the interlock monitor switch.

1. When mounting Primary switch and Interlock Monitor switch to Latch Body, consult the figure.
2. No specific adjustment during installation of Primary switch and Monitor switch to the latch body is necessary.
3. When mounting the Latch Body to the oven assembly, adjust the Latch Body by moving it so that the oven door will not have any play in it. Check for play in the door by pulling the door assembly. Make sure that the latch keys move smoothly after adjustment is completed. Completely tighten the screws holding the Latch Body to the oven assembly.
4. Reconnect to Monitor switch and check the continuity of the monitor circuit and all latch switches again by following the components test procedures.
5. Confirm that the gap between the switch housing and the switch actuator is no more than 0.5mm when door is closed.
6. **Interlock Switch Replacement** - When replacing faulty switches, be sure switch mounting tabs are not bent, broken or otherwise deficient in their ability to secure the switches in place.

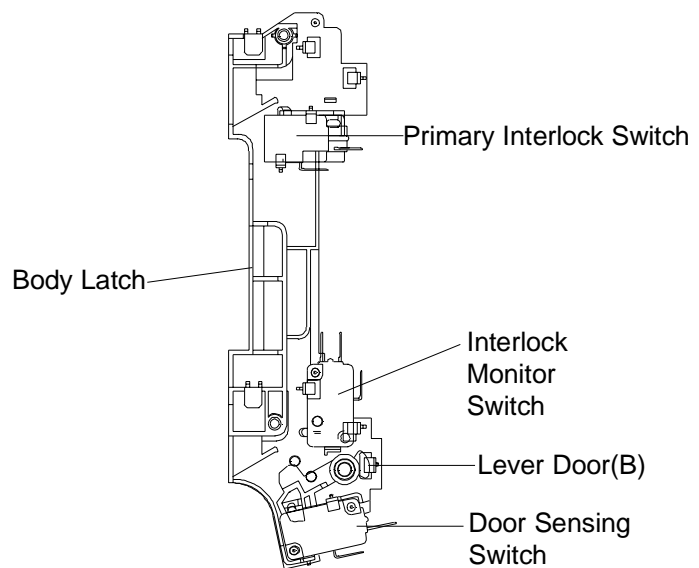

	Door Open	Door Closed
Primary switch	$\infty$	0
Monitor switch (COM-NC)	0	$\infty$
Monitor switch (COM-NO)	$\infty$	0
Door Sensing S/W	$\infty$	0

## 5-6 Output Power of Magnetron

### CAUTION MICROWAVE RADIATION

PERSONNEL SHOULD NOT ALLOW EXPOSURE TO MICROWAVE RADIATION FROM MICROWAVE GENERATOR OR OTHER PARTS CONDUCTING MICROWAVE ENERGY.

The output power of the magnetron can be measured by performing a water temperature rise test.

Equipment needed :

\* Two 1-liter cylindrical borosilicate glass vessel (Outside diameter 190 mm)

\* One glass thermometer with mercury column

NOTE: Check line voltage under load. Low voltage will lower the magnetron output. Make all temperature and time tests with accurate equipment.

1. Fill the one liter glass vessel with water.
2. Stir water in glass vessel with thermometer, and record glass vessel's temperature ("T1", 10±1°C).
3. After moving the water into another glass vessel, place it in the center of the cooking tray. Set the oven to high power and operate for 55seconds exactly. (3 seconds included as a holding time of magnetron oscillation:)
4. When heating is finished, stir the water again with the thermometer and measure the temperature ("T2").
5. Subtract T1 from T2. This will give you the water temperature rise. ( $\Delta T$ )
6. The output power is obtained by the following formula;

$$\text{Output Power} = \frac{4.187 \times 1000 \times \Delta T + 0.55 \times M_c \times (T_2 - T_0)}{52}$$

55 : Heating Time (sec)

52 : Counting Time (sec)

4.187 : Coefficient for Water

1000 : Water (cc)

$\Delta T$  : Temperature Rise (T2-T1)

T<sub>0</sub> : Room Temperature

M<sub>c</sub> : Cylindrical borosilicate glass weight

7. Normal temperature rise for this model is 9°C to 11°C at 'HIGH'.

NOTE 1: Variations or errors in the test procedure will cause a variance in the temperature rise.

Additional power test should be made if temperature rise is marginal.

NOTE 2: Output power in watts is computed by multiplying the temperature rise (step 5) by a factor of 91 times the of centigrade temperature.

## 5-7 Microwave Heat Distribution - Heat Evenness

The microwave heat distribution can be checked indirectly by measuring the water temperature rise at certain positions in the oven:

1. Prepare five beakers made of 'Pyrex', having 100 milliliters capacity each.
2. Measure exactly 100milliliters off water load with a measuring cylinder, and pour into each beaker.
3. Measure the temperature of each water load. (Readings shall be taken to the first place of decimals.)
4. Put each beaker in place on the cooking tray as illustrated in figure below. Start heating.
5. After heating for 2 minutes, measure the water temperature in each beaker.
6. Microwave heat distribution rate can be calculated as follows:

$$\text{Heat Distribution} = \frac{\text{Minimum Temperature Rise}}{\text{Maximum Temperature Rise}} \times 100(\%)$$

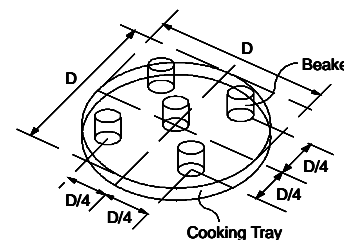

The result should exceed 65%.

---

## 5-8 Procedure for Measurement of Microwave Energy Leakage

---

- 1) Pour 275±15cc of 20±5°C(68±9°F) water in a beaker which is graduated to 600cc, and place the beaker in the center of the oven.
- 2) Start to operate the oven and measure the leakage by using a microwave energy survey meter.
- 3) Set survey meter with dual ranges to 2,450MHz.
- 4) When measuring the leakage, always use the 2 inch spacer cone with the probe. Hold the probe perpendicular to the cabinet door. Place the spacer cone of the probe on the door and/or cabinet door seam and move along the seam, the door viewing window and the exhaust openings moving the probe in a clockwise direction at a rate of 1 inch/sec. If the leakage testing of the cabinet door seam is taken near a corner of the door, keep the probe perpendicular to the areas making sure that the probe end at the base of the cone does not get closer than 5cm to any metal. If it gets closer than 5cm, erroneous readings may result.
- 5) Measured leakage must be less than 4mW/cm<sup>2</sup>, after repair or adjustment.

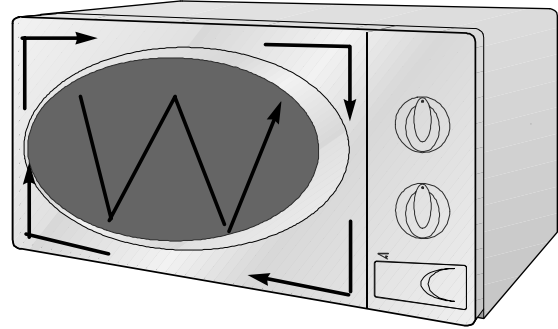

Maximum allowable leakage is 5mW/cm<sup>2</sup>.  
4mW/cm<sup>2</sup> is used to allow for measurement and meter accuracy

---

## 5-9 Check for Microwave Leakage

---

1. Remove the outer panel.
2. Pour 275±15cc of 20±5°C(68±9°F) water in a beaker which is graduated to 600cc, and place the beaker in the center of the oven.
3. Start the oven at the highest power level.
4. Set survey meter dual ranges to 2,450MHz.
5. Using the survey meter and spacer cone as described above, measure near the opening of magnetron, the surface of the air guide and the surface of the wave guide as shown in the following photo. ( but avoid the high voltage components.) The reading should be less than 4mW/cm<sup>2</sup>.

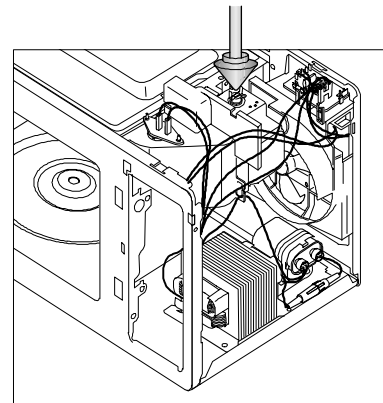

---

## 5-10 Note on Measurement

---

- 1) Do not exceed the limited scale.
- 2) The test probe must be held on the grip of the handle, otherwise a false reading may result when the operator's hand is between the handle and the probe.
- 3) When high leakage is suspected, do not move the probe horizontally along the oven surface; this may cause damage to the probe.
- 4) Follow the recommendation of the manufacturer of the microwave energy survey meter.

---

## 5-11 Leakage Measuring Procedure

---

### 5-11-1 Record keeping and notification after measurement

- 1) After adjustment and repair of a radiation preventing device, make a repair record for the measured values, and keep the data.
- 2) If the radiation leakage is more than 4 mW/cm<sup>2</sup> after determining that all parts are in good condition, functioning properly and the identical parts are replaced as listed in this manual notify that fact to ;

### CENTRAL SERVICE CENTER

- 5-11-2 At least once a year have the microwave energy survey meter checked for accuracy by its manufacturer.

## 6. Troubleshooting

### WARNING FOR HIGH VOLTAGE

4000 VOLTS EXIST AT THE HIGH VOLTAGE AREA. DO NOT OPERATE THE OVEN WITH CABINET PARTS REMOVED. DO NOT REMOVE THE CABINET PARTS IF THE POWER SUPPLY CORD IS PLUGGED IN THE WALL OUTLET. UNPLUG THE POWER CORD BEFORE SERVICING.

### 6-1 Electrical Malfunction

Parts	Cause	Diagnosis	Remedy
Fuse blows out when door is opened.	Defective primary interlock switch any winding.	Check continuity of the primary switch terminals with wire removed using a multimeter. If there is continuity inter between switch terminals when door is opened,the switch is defective.	Replace the primary interlock switch
	Defective interlock monitor switch	Check continuity of the monitor switch terminals with wire removed by using a multimeter. If there is continuity between switch terminals the door is closed, the switch is defective.	Replace the interlock monitor switch
Fuse is Open	Layer short of the secondary coil of H. V. Transformer	The fuse will not blow right away, but if it blows in a few seconds, then there is a layer short If the fuse blows with H. V. Trans secondary open, the transformer may be faulty.	Replace H. V.Transformer
Oven lamp does not light.	1) Fuse blown out	Check fuse.	Replace the fuse.
	2) Poor contact of power cord.	Check continuity of power supply cord. Also check whether the power cord is securely wired.	Adjust or replace the power supply cord
	3) Defective lamp	The fan motor rotates, but lamp does not light.	Replace the lamp.
	4) Defective timer contacts	Check the terminals of timer for continuity,turning the timer knob ON and OFF repeatedly.	Replace the timer.
	5) Thermal cutout S/W open	In this case the oven lamp and fan do not turn on	Replace the thermal cutout S/W
Fan does not operate.	1) Defective fan motor.	If 230V is found at motor terminals, the motor should be replaced.	Replace the motor.
	2) Defective contacts of timer	The oven lamp does not light and fan motor does not operate.	Replace the timer.

NOTE : Interlock monitor switch must be replaced when the fuse is blown out.

## 6-1 Electrical Malfunction(continued)

part	Cause	Diagnosis	Remedy
Microwave turns off during cooking cycle.	1) Too small a load	If a small amount of food is heated for a long time, period of microwave may turn off during operation.	To increase the oven water into water into the oven.
	2) Defective magnetron thermal cutout S/W	Check to see if the magnetron thermal cutout switch is activated at a temperature higher than 150 °C.	Replace thermal cutout switch.
properly shock is felt.	In complete grounding	Make sure that grounding of the power supply cord has been done properly.	Rewire.
Door doe not operate properly	1) Broken door hinges	Remove the cabinet for inspection. Check the door hinge.	Replace door hinges.
	2) Missing or loose screw	Check if the screws are secured well to the door hinge.	Fasten or tighten.
Timer does not operate.	1) Defective timer motor	If the timer does not operate with 21V applied to the terminals, the timer motor amy be faulty.	Replace timer.
	2) Defective contacts of timer S/W	The lamp does not light.	Replace timer
Cooking tray does not rotate.	1) Defective drive motor	Check to see if 21V exists at the motor terminals.If so, motor will be defective.	Replace drive motor.
	1) Blocking of the ventilator	Check if the air inlet or outlet ventilation is blocked by the wall or other objects.	Keep a distance of 100mm from the wall or the objects.
Magnetron thermal cutout switch OFF	2) Defective fan motor	If the fan motor does not operate with 230V applied to the terminal, the motor may be faulty.	Replace fan motor.
	3) Too small a load or no load	If a small amount of food is heated repeatedly over a long period of time, microwave turns off during operation.	To increase the oven load, place a glass of water into the oven.



## 6-2 Unsatisfactory Cooking

Parts	Cause	Diagnosis	Remedy
Food is not heated.	1) Open cathode of magnetron	Check the terminals with a multimeter to see if the heater circuit is open.	Replace magnetron.
	2) Defective H. V. Diode	Check the H. V. Diode for continuity in the reverse and normal directions using megger. If there is continuity in the reverse direction, the H. V. Diode may be faulty. (In this event H. V. Capacitor will be hot)	Replace H. V. Diode.
	3) Shorted magnetron	Connect megger leads to quick-connect terminal & body of the magnetron if there is continuity, the magnetron may be fuse will be blown) faulty. (In this case the main fuse will be blown)	Replace magnetron.
	4) Defective magnetron	If there is a crack in the magnetron antenna (dome), the magnetron is defective.	Replace magnetron.
	5) Poor contact of primary interlock switch	Check if the screws are secured well to the door hinge. and pressing it ON and OFF repeatedly.	Replace or adjust.
	6) Open coil of H. V. Transformer	Check the continuity of primary coil and secondary coil. If there is no continuity, H. V. Transformer is defective.	Replace the H. V. Transformer.
	7) Shorted H. V. capacitor	Check the continuity of capacitor. If the capacitor shorts, the fuse blows	Replace the H. V. Capacitor.
	8) Monitor fuse blown out	Check the monitor fuse (on the noise filter)	Replace the Monitor fuse

## 6-3 Part Check List

Symptom	Related Parts	Check Points	Remedy
Microwave cooking does not work.	H.V.Transformer	1) Check if the primary and secondary coil is open or shorted. * Resistance of primary coil: . 2.5Ω Approx Resistance of secondary coil: Approx. 151.5Ω 2) Check if the MGT Heater Voltage is approx. 3.3V AC. <b>Caution : High voltage !</b>	Replace.
	H.V.Capacitor	Check continuity of capacitor between two terminals with H.V.wire lead removed. The resistance should be approx. 10MΩ, it's failure..	Replace.
	H.V.Diode	1) If there is no continuity in forward, direction the H.V.Diode is open. 2) If there is continuity in reverse direction, it's shorted.	Replace.
Fan motor does not rotate.	Fan motor	Check if the motor coil is open.	Replace.

# 7. Exploded Views and Parts List

## 7-1 Exploded Views

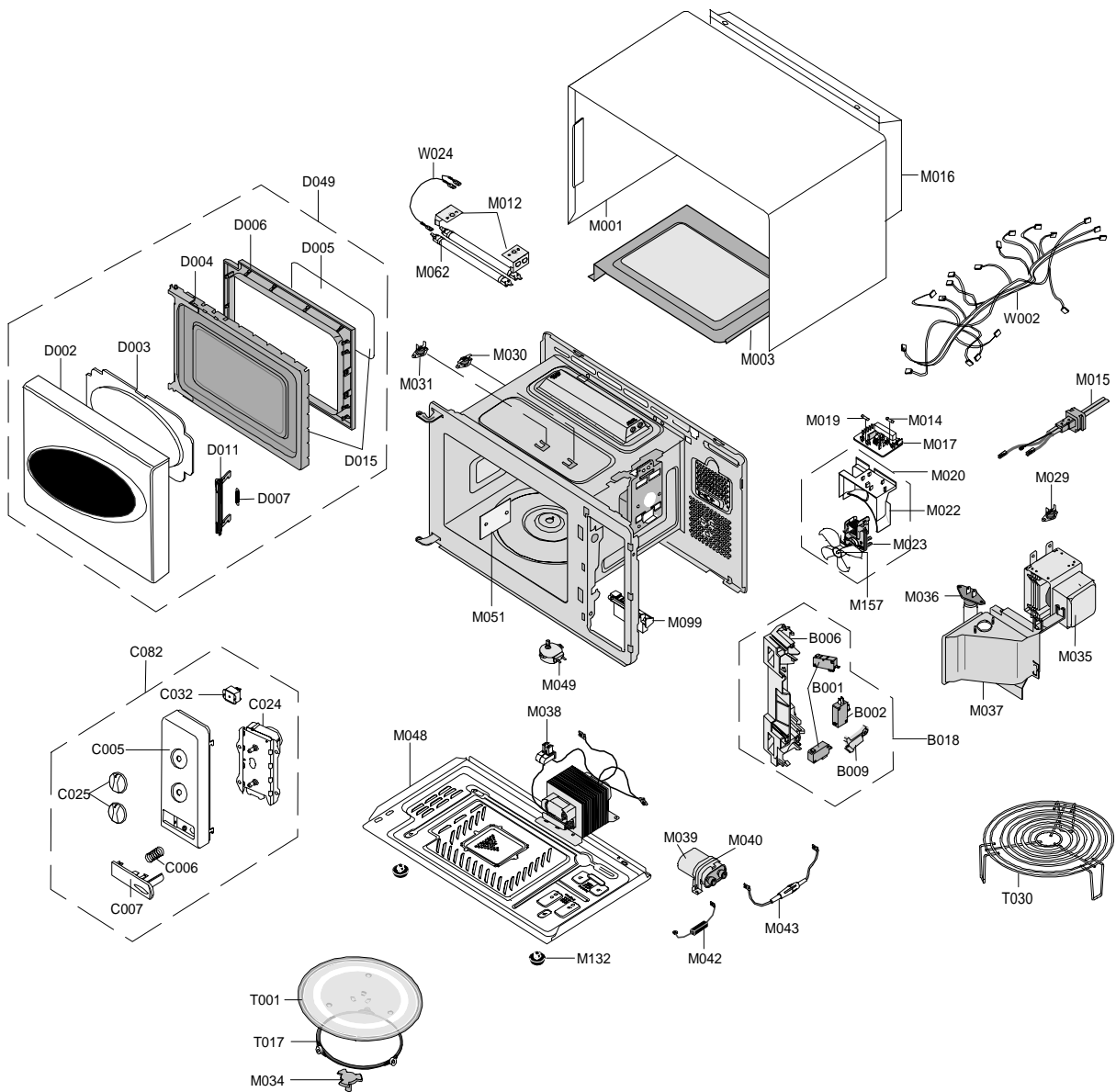

## 7-2 Main Parts List

No.	Code No.	Description	Specification	Q'ty	Remark
B001	3405-001034	SWITCH-MICRO	125/250VAC,16A,200GF,SPST-N	1	PRI
B002	3405-001032	SWITCH-MICRO	125/250VAC,16A,200GF,SPDT	1	
B006	DE72-00138A	BODY-LATCH	NC2000(0.6/0.8/1.2),PP,-,-,-	1	
B009	DE66-00088A	LEVER-SWITCH	NC2000(0.6/0.8/1.2),PP,-,-	1	
B018	DE96-00115C	ASSY BODY LATCH	CE2611N,NC2000(BUTTON)	1	
M001	DE70-00184P	PANEL-OUTER	MW850WA,C/STEEL,T0.5,-,-,-,P	1	
M003	DE61-00263A	BRACKET-UPPER	N7Q88,SECC,T0.5,-,-,-,QUAR	1	
M012	DE61-00265A	BRACKET-HEATER	N7Q88,ALSTAR,T0.5,W49.5,L	2	
M014	3601-001126	FUSE-CARTRIDGE	250V,1.6A,FAST-ACTING,CER	1	
M015	DE39-20058L	ASSY POWER CORD	CE2713/XEF,1.5SQ,230V50H	1	
M016	DE71-60298A	COVER-BACK	-,SECC,T0.6,W273,L633,-,M6Q45	1	
M017	DE96-00008D	ASSY NOISE FILTER	SN-3WEB(12),250V12A,EU	1	
M019	3601-001019	FUSE-CARTRIDGE	250V,12A,SLOW-BLOW,CERAMI	1	
M020	DE96-00031A	ASSY-MOTOR FAN	SMF-3RDEA,230V50HZ,2400RP	1	
M022	DE71-00148A	COVER-BLOWER	MW850WA,PP,T1.5,-,-,-,NTR,N	1	
M023	DE31-10184A	MOTOR FAN	SMF-3RDEA,230V50Hz,2400rpm,3rd	1	
M029	DE47-20009A	THERMOSTAT	PW2N-520PB,160/60,250V/7.5A,H	1	MGT
M030	DE47-00002B	THERMOSTAT	PW2N,-,-,100,110,-,-,-,187H,3	1	CAVITY
M031	DE47-20032A	THERMOSTAT	PW-2N,85/75,-,-,-,-,-	1	GRILL
M034	DE67-00140A	COUPLER	NC2000(0.6~0.8),PPS(ESS840),-,3G	1	
M035	OM75S(31)ERHN	ASSY-MAGNETRON	OM75S(31)ERHN	1	
M036	4713-001046	LAMP-INCANDESCENT	240V,104mA,25W,ORG,-,-	1	CV/AIR
M037	DE71-60457B	COVER-AIR	3RD-0.7(BTM),PP,-,-,-,-,-	1	
M038	DE26-00079A	TRANS H.V	SHV-EURO1,230V,50HZ,2130V/3.6V	1	
M039	2501-001011	C-OIL	910nF,2100V,BK,54x35x75mm,20mm	1	
M040	DE61-00139A	BRACKET-HVC	NC2000,SECC,T0.8,-,-,-,0.6/0	1	
M042	DE59-00002A	DIODE-H.V	ESJC13-12B,12KV,-,-,-,MWO ALL,	1	
M043	DE91-70061J	ASSY-H.V.FUSE	THV060T-0650-H,5KV0.65A,WL	1	
M048	DE80-00023A	BASE-PLATE	MW850WA,SGCC1,T0.6,-,-,-,NC2000	1	
M049	DE31-10154A	MOTOR SYNCHRONOUS	M2HJ49ZR02,ST-16,50/60	1	
M051	DE71-00151A	COVER-MGT	MW850WA,PP,T2,W54,L129,-,GE-WH	1	
M062	DE47-70030D	HEATER-CERAMIC	115V,490W,26OHM,6,-,-,-,-	2	
M099	DE66-90113A	LEVER-DOOR	PP(TB53-GH41),T2.5,-,-,-,12g,NT	1	
M132	DE61-40066A	FOOT	-,PP,-,BLK,-,-,-	2	
M157	DE31-90057A	BLADE-FAN	PP,T1.5,-,3RD-W,-,-,-	1	
T001	DE74-20102B	TRAY-COOKING	GLASS,T5.0,M745,-,-	1	
T017	DE97-00193B	ASSY-GUIDE ROLLER	NC2000 0.6,T2*P1198(14	1	
T030	DE74-70071D	RACK-WIRE	MSWR10,PI3,0.7/NC2000,D230,H85	1	
W002	DE39-00334A	WIRE HARNESS-A	G2712N,230V50HZ,EUROPE QU	1	
W024	DE39-30097B	LEAD WIRE-G	L100,MBQ45,GRILL,-,-,-,-	1	

## 7-3 Control & Door Parts List

No.	Code No.	Description	Specification	Q'ty	Remark
C005	DE72-00176D	CONTROL-PANEL	G2711N/XET,ABS,-,-,-,PUR	1	
C006	DE61-70076A	SPRING-BUTTON	-,HSWR,PI0.6,-,OD19,L23,5T	1	
C007	DE67-00120A	BUTTON-PUSH	N8A77(CHINA),ABS,-,-,P/WHT,-	1	
C024	DE45-00003A	TIMER	TMFK60M1A1,-,-,-,-,310 GRILL	1	
C025	DE64-00276A	KNOB	N8A77,ABS,-,-,-,P/WHT(W9501),-,N8	2	
C032	3501-000309	RELAY-POWER	240V,3750VA,15000MA,-,6MS,20	1	
C082	DE94-00493D	ASSY CONTROL-BOX	230V50HZ,G2711N/XET,PUR	1	S.N.A
D002	DE64-00277B	DOOR-A	M1711N/XET,ABS,PURE-WHT,SEI,TDS,-	1	
D003	DE63-00056B	SCREEN-DOOR	M1711N/G2711N,SAN,SMOG,SILK{	1	
D004	DE92-50133C	ASSY DOOR-E	MW4593G,-,BLK,3RD-0.7	1	
D005	DE01-00112A	FILM-DOOR	-,PET,-,L268,T0.15,W150,NTR,-	1	
D006	DE64-40008B	DOOR-C	-,PP,CE745G,-,-,BLK,-	1	
D007	DE61-00198A	SPRING-KEY	M1877,HSWR,PI0.7,-,D6,23 1/4,	1	
D011	DE64-00210A	KEY-DOOR	NC2000(0.6/0.8/1.2),PP,-,BLK,-,	1	
D015	DE94-00124B	ASSY DOOR-SUB	MW4593G,BLK,3RD-0.7,-,-,-,	1	
D049	DE94-00494B	ASSY DOOR	M1711N/XET,PURE-WHT,SEI,TDS+SA	1	S.N.A

S.N.A : SERVICE NOT AVAILABLE

## 7-4 Standard Parts List

Code No.	Description	Specification	Q'ty	Remark
DE60-10012A	SCREW-TAP TITE	-,SWR10,M4,L10,TH,+,-,3,ZPC2,-	1	N/P EARTH
DE60-10012A	SCREW-TAP TITE	-,SWR10,M4,L10,TH,+,-,3,ZPC2,-	1	P/C EARTH
DE60-10012A	SCREW-TAP TITE	-,SWR10,M4,L10,TH,+,-,3,ZPC2,-	1	PCB EARTH
DE60-10012A	SCREW-TAP TITE	-,SWR10,M4,L10,TH,+,-,3,ZPC2,-	1	TCO-S/W
DE60-10063A	SCREW-TAP TH	-,FEFN,-,TH,M4,-,L12,-,-	1	O/PANEL
DE60-10080B	SCREW-WASHER	-,2S,SWRCH18A,ZP2,PH,PI5,-,L10,-,-	4	HVT
DE60-10080B	SCREW-WASHER	-,2S,SWRCH18A,ZP2,PH,PI5,-,L10,-,-	4	MGT
DE60-10082H	SCREW-A	-,,-,-,2S-4X12,TOOTHED,-,-,-,-	1	AIR/COVER
DE60-10082H	SCREW-A	-,,-,-,2S-4X12,TOOTHED,-,-,-,-	2	B/LATCH
DE60-10082H	SCREW-A	-,,-,-,2S-4X12,TOOTHED,-,-,-,-	3	B/PLATE
DE60-10082H	SCREW-A	-,,-,-,2S-4X12,TOOTHED,-,-,-,-	1	C/BLOWER
DE60-10082H	SCREW-A	-,,-,-,2S-4X12,TOOTHED,-,-,-,-	1	C/BOX
DE60-10082H	SCREW-A	-,,-,-,2S-4X12,TOOTHED,-,-,-,-	4	O/PANEL
DE60-10098A	SCREW-ASSY TAP TITE	-,GLD,SWRCH18A,ZPC2,PH,TC,-,M4X8,WT,-	1	D/MOTOR
DE60-30016A	NUT-FLANGE	M4,MSWR10,-,-,-,-,-,-,-	2	F-MOTOR
DE60-10069A	SCREW-TAP TH	-,FRFZY,-,TH,M4,-,L10,-,-	1	RELAY
DE60-10069A	SCREW-TAP TH	-,FRFZY,-,TH,M4,-,L10,-,-	4	TIMER
DE60-10012A	SCREW-TAP TITE	-,SWR10,M4,L10,TH,+,-,3,ZPC2,-	1	B/COVER
DE60-10098A	SCREW-ASSY TAP TITE	-,GLD,SWRCH18A,ZPC2,PH,TC,-,M4X8,WT,-	1	HVD

# 8. Schematic Diagrams

## 8-1 Schematic Diagrams

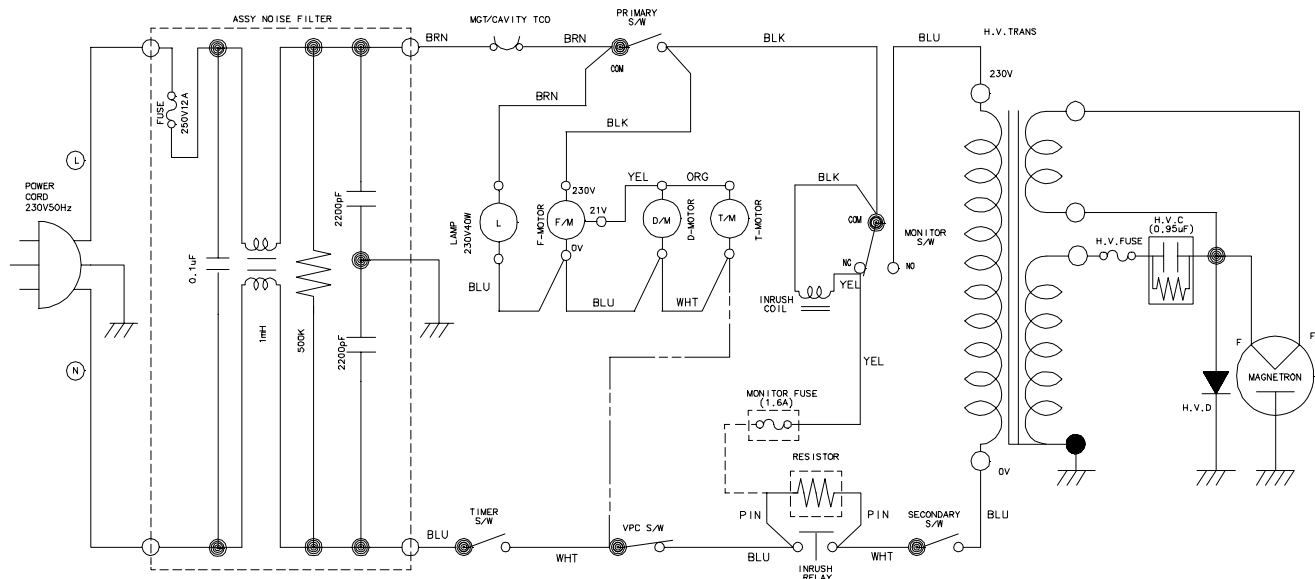

**NOTE**

1. INPUT : 230V
2. DOOR : OPEN
3. LAMP : ON
4. --- : ASSY NOISE FILTER PATTERN
5. — : TIMER SHORT

SYMBOL	COLOR
BRN	BROWN
RED	RED
BLU	BLUE
YEL	YELLOW
PIN	PINK
Y/G	YELLOW/GREEN
ORG	ORANGE
WHT	WHITE
BLK	BLACK
GRN	GREEN

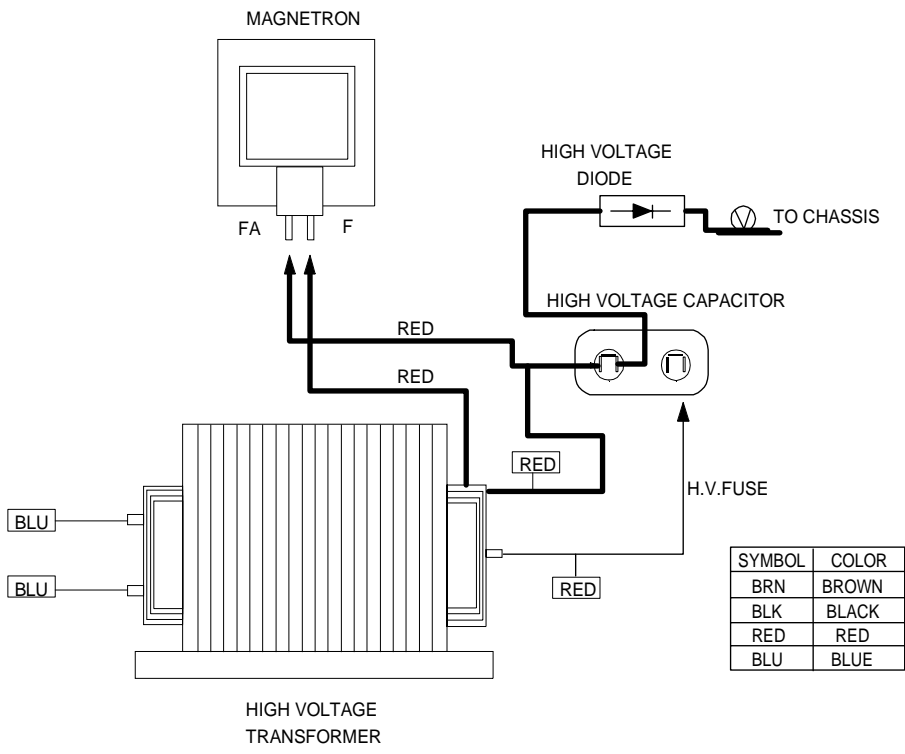



© Samsung Electronics Co., Ltd. May 2003  
Printed in Korea  
Code No. : DE68-03136A