



OM-1500-13

207 494E

May 2004

Processes



MIG (GMAW) Welding
Flux Cored (FCAW) Welding
(Gas-and Self-Shielding)
Submerged (SAW) Welding

Description



Wire Feeder

(Use with CV Power Sources)

DS-74S/D Swingarc™

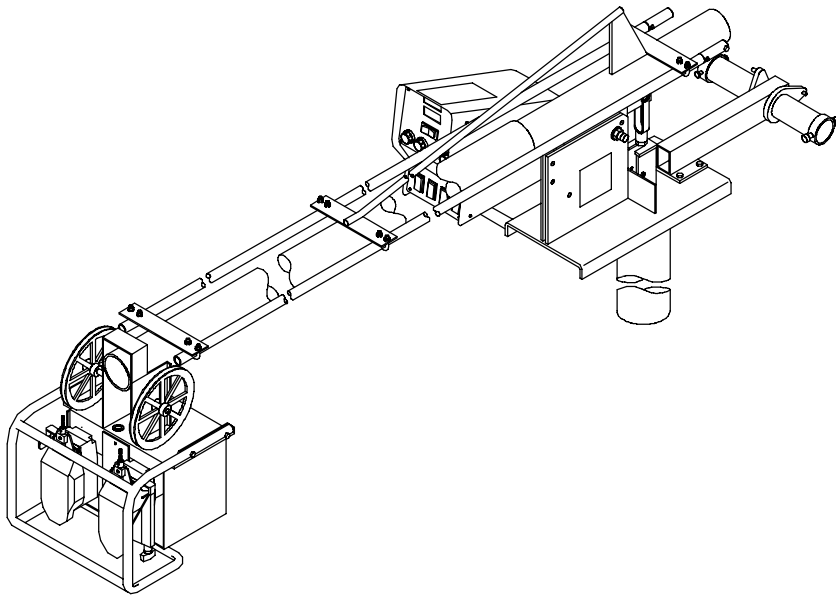

DS-74S12, DS-74S16, DS-74D12, and DS-74D16

OWNER'S MANUAL



Visit our website at
www.MillerWelds.com

From Miller to You

Thank you and congratulations on choosing Miller. Now you can get the job done and get it done right. We know you don't have time to do it any other way.

That's why when Niels Miller first started building arc welders in 1929, he made sure his products offered long-lasting value and superior quality. Like you, his customers couldn't afford anything less. Miller products had to be more than the best they could be. They had to be the best you could buy.

Today, the people that build and sell Miller products continue the tradition. They're just as committed to providing equipment and service that meets the high standards of quality and value established in 1929.

This Owner's Manual is designed to help you get the most out of your Miller products. Please take time to read the Safety precautions. They will help you protect yourself against potential hazards on the worksite.

We've made installation and operation quick and easy. With Miller you can count on years of reliable service with proper maintenance. And if for some reason the unit needs repair, there's a Troubleshooting section that will help you figure out what the problem is. The parts list will then help you to decide the exact part you may need to fix the problem. Warranty and service information for your particular model are also provided.



Miller is the first welding equipment manufacturer in the U.S.A. to be registered to the ISO 9001:2000 Quality System Standard.



Miller Electric manufactures a full line of welders and welding related equipment. For information on other quality Miller products, contact your local Miller distributor to receive the latest full line catalog or individual catalog sheets. **To locate your nearest distributor or service agency call 1-800-4-A-Miller, or visit us at www.MillerWelds.com on the web.**



Working as hard as you do – every power source from Miller is backed by the most hassle-free warranty in the business.



TABLE OF CONTENTS

SECTION 1 – SAFETY PRECAUTIONS - READ BEFORE USING	1
1-1. Symbol Usage	1
1-2. Arc Welding Hazards	1
1-3. Additional Symbols For Installation, Operation, And Maintenance	3
1-4. California Proposition 65 Warnings	3
1-5. Principal Safety Standards	4
1-6. EMF Information	4
SECTION 2 – CONSIGNES DE SÉCURITÉ – À LIRE AVANT UTILISATION	5
2-1. Signification des symboles	5
2-2. Dangers relatifs au soudage à l'arc	5
2-3. Autres symboles relatifs à l'installation, au fonctionnement et à l'entretien de l'appareil.	7
2-4. Principales normes de sécurité	8
2-5. Information sur les champs électromagnétiques	8
SECTION 3 – INTRODUCTION	9
3-1. Specifications	9
SECTION 4 – INSTALLATION	9
4-1. Installing Swivel Into Pipe Post	9
4-2. Installing Control Box And Adjusting Tilt	10
4-3. Installing Boom And Reel Support	10
4-4. Installing Wire Guide Extension	11
4-5. Equipment Connection Diagram	12
4-6. Control Box Connections	13
4-7. 14-Pin Plug Information	13
4-8. Removing Safety Collar And Adjusting Boom	14
4-9. Gun Recommendation Table	14
4-10. Wire Type, Size, And Feed Speed Capability Table	14
4-11. Installing And Threading Welding Wire	15
4-12. Setting Internal DIP Switches	16
4-13. Optional Equipment DIP Switch Settings	17
SECTION 5 – OPERATION	18
5-1. Power Switch	18
5-2. Left/Right Select Switch	18
5-3. Jog/Purge	18
5-4. Trigger Hold Switch	19
5-5. Voltage Control And Digital Meters	19
SECTION 6 – MAINTENANCE & TROUBLESHOOTING	20
6-1. Routine Maintenance	20
6-2. Diagnostics	21
6-3. Troubleshooting	22
SECTION 7 – ELECTRICAL DIAGRAM	24
SECTION 8 – PARTS LIST	26
OPTIONS AND ACCESSORIES	
WARRANTY	

SECTION 1 – SAFETY PRECAUTIONS - READ BEFORE USING

som _8/03

1-1. Symbol Usage



Means Warning! Watch Out! There are possible hazards with this procedure! The possible hazards are shown in the adjoining symbols.

▲ Marks a special safety message.

☞ Means "Note"; not safety related.



This group of symbols means Warning! Watch Out! possible ELECTRIC SHOCK, MOVING PARTS, and HOT PARTS hazards. Consult symbols and related instructions below for necessary actions to avoid the hazards.

1-2. Arc Welding Hazards

▲ The symbols shown below are used throughout this manual to call attention to and identify possible hazards. When you see the symbol, watch out, and follow the related instructions to avoid the hazard. The safety information given below is only a summary of the more complete safety information found in the Safety Standards listed in Section 1-5. Read and follow all Safety Standards.

▲ Only qualified persons should install, operate, maintain, and repair this unit.

▲ During operation, keep everybody, especially children, away.



ELECTRIC SHOCK can kill.

Touching live electrical parts can cause fatal shocks or severe burns. The electrode and work circuit is electrically live whenever the output is on. The input power circuit and machine internal circuits are also

live when power is on. In semiautomatic or automatic wire welding, the wire, wire reel, drive roll housing, and all metal parts touching the welding wire are electrically live. Incorrectly installed or improperly grounded equipment is a hazard.

- Do not touch live electrical parts.
- Wear dry, hole-free insulating gloves and body protection.
- Insulate yourself from work and ground using dry insulating mats or covers big enough to prevent any physical contact with the work or ground.
- Do not use AC output in damp areas, if movement is confined, or if there is a danger of falling.
- Use AC output ONLY if required for the welding process.
- If AC output is required, use remote output control if present on unit.
- Disconnect input power or stop engine before installing or servicing this equipment. Lockout/tagout input power according to OSHA 29 CFR 1910.147 (see Safety Standards).
- Properly install and ground this equipment according to its Owner's Manual and national, state, and local codes.
- Always verify the supply ground – check and be sure that input power cord ground wire is properly connected to ground terminal in disconnect box or that cord plug is connected to a properly grounded receptacle outlet.
- When making input connections, attach proper grounding conductor first – double-check connections.
- Frequently inspect input power cord for damage or bare wiring – replace cord immediately if damaged – bare wiring can kill.
- Turn off all equipment when not in use.
- Do not use worn, damaged, undersized, or poorly spliced cables.
- Do not drape cables over your body.

- If earth grounding of the workpiece is required, ground it directly with a separate cable.
- Do not touch electrode if you are in contact with the work, ground, or another electrode from a different machine.
- Use only well-maintained equipment. Repair or replace damaged parts at once. Maintain unit according to manual.
- Wear a safety harness if working above floor level.
- Keep all panels and covers securely in place.
- Clamp work cable with good metal-to-metal contact to workpiece or worktable as near the weld as practical.
- Insulate work clamp when not connected to workpiece to prevent contact with any metal object.
- Do not connect more than one electrode or work cable to any single weld output terminal.

SIGNIFICANT DC VOLTAGE exists after removal of input power on inverters.

- Turn Off inverter, disconnect input power, and discharge input capacitors according to instructions in Maintenance Section before touching any parts.



FUMES AND GASES can be hazardous.

Welding produces fumes and gases. Breathing these fumes and gases can be hazardous to your health.

- Keep your head out of the fumes. Do not breathe the fumes.
- If inside, ventilate the area and/or use exhaust at the arc to remove welding fumes and gases.
- If ventilation is poor, use an approved air-supplied respirator.
- Read the Material Safety Data Sheets (MSDSs) and the manufacturer's instructions for metals, consumables, coatings, cleaners, and degreasers.
- Work in a confined space only if it is well ventilated, or while wearing an air-supplied respirator. Always have a trained watch-person nearby. Welding fumes and gases can displace air and lower the oxygen level causing injury or death. Be sure the breathing air is safe.
- Do not weld in locations near degreasing, cleaning, or spraying operations. The heat and rays of the arc can react with vapors to form highly toxic and irritating gases.
- Do not weld on coated metals, such as galvanized, lead, or cadmium plated steel, unless the coating is removed from the weld area, the area is well ventilated, and if necessary, while wearing an air-supplied respirator. The coatings and any metals containing these elements can give off toxic fumes if welded.



ARC RAYS can burn eyes and skin.

Arc rays from the welding process produce intense visible and invisible (ultraviolet and infrared) rays that can burn eyes and skin. Sparks fly off from the weld.

- Wear a welding helmet fitted with a proper shade of filter to protect your face and eyes when welding or watching (see ANSI Z49.1 and Z87.1 listed in Safety Standards).
- Wear approved safety glasses with side shields under your helmet.
- Use protective screens or barriers to protect others from flash and glare; warn others not to watch the arc.
- Wear protective clothing made from durable, flame-resistant material (leather and wool) and foot protection.



WELDING can cause fire or explosion.

Welding on closed containers, such as tanks, drums, or pipes, can cause them to blow up. Sparks can fly off from the welding arc. The flying sparks, hot workpiece, and hot equipment can cause fires and burns. Accidental contact of electrode to metal objects can cause sparks, explosion, overheating, or fire. Check and be sure the area is safe before doing any welding.

- Protect yourself and others from flying sparks and hot metal.
- Do not weld where flying sparks can strike flammable material.
- Remove all flammables within 35 ft (10.7 m) of the welding arc. If this is not possible, tightly cover them with approved covers.
- Be alert that welding sparks and hot materials from welding can easily go through small cracks and openings to adjacent areas.
- Watch for fire, and keep a fire extinguisher nearby.
- Be aware that welding on a ceiling, floor, bulkhead, or partition can cause fire on the hidden side.
- Do not weld on closed containers such as tanks, drums, or pipes, unless they are properly prepared according to AWS F4.1 (see Safety Standards).
- Connect work cable to the work as close to the welding area as practical to prevent welding current from traveling long, possibly unknown paths and causing electric shock and fire hazards.
- Do not use welder to thaw frozen pipes.
- Remove stick electrode from holder or cut off welding wire at contact tip when not in use.
- Wear oil-free protective garments such as leather gloves, heavy shirt, cuffless trousers, high shoes, and a cap.
- Remove any combustibles, such as a butane lighter or matches, from your person before doing any welding.

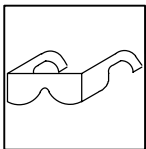

FLYING METAL can injure eyes.

- Welding, chipping, wire brushing, and grinding cause sparks and flying metal. As welds cool, they can throw off slag.
- Wear approved safety glasses with side shields even under your welding helmet.



BUILDUP OF GAS can injure or kill.

- Shut off shielding gas supply when not in use.
- Always ventilate confined spaces or use approved air-supplied respirator.



HOT PARTS can cause severe burns.

- Do not touch hot parts bare handed.
- Allow cooling period before working on gun or torch.

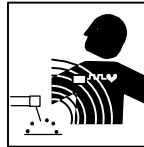

MAGNETIC FIELDS can affect pacemakers.

- Pacemaker wearers keep away.
- Wearers should consult their doctor before going near arc welding, gouging, or spot welding operations.

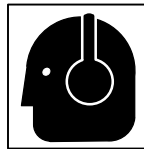

NOISE can damage hearing.

Noise from some processes or equipment can damage hearing.

- Wear approved ear protection if noise level is high.

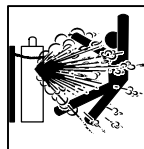

CYLINDERS can explode if damaged.

Shielding gas cylinders contain gas under high pressure. If damaged, a cylinder can explode. Since gas cylinders are normally part of the welding process, be sure to treat them carefully.

- Protect compressed gas cylinders from excessive heat, mechanical shocks, slag, open flames, sparks, and arcs.
- Install cylinders in an upright position by securing to a stationary support or cylinder rack to prevent falling or tipping.
- Keep cylinders away from any welding or other electrical circuits.
- Never drape a welding torch over a gas cylinder.
- Never allow a welding electrode to touch any cylinder.
- Never weld on a pressurized cylinder – explosion will result.
- Use only correct shielding gas cylinders, regulators, hoses, and fittings designed for the specific application; maintain them and associated parts in good condition.
- Turn face away from valve outlet when opening cylinder valve.
- Keep protective cap in place over valve except when cylinder is in use or connected for use.
- Read and follow instructions on compressed gas cylinders, associated equipment, and CGA publication P-1 listed in Safety Standards.

1-3. Additional Symbols For Installation, Operation, And Maintenance



FIRE OR EXPLOSION hazard.

- Do not install or place unit on, over, or near combustible surfaces.
- Do not install unit near flammables.
- Do not overload building wiring – be sure power supply system is properly sized, rated, and protected to handle this unit.



MOVING PARTS can cause injury.

- Keep away from moving parts such as fans.
- Keep all doors, panels, covers, and guards closed and securely in place.



FALLING UNIT can cause injury.

- Use lifting eye to lift unit only, NOT running gear, gas cylinders, or any other accessories.
- Use equipment of adequate capacity to lift and support unit.
- If using lift forks to move unit, be sure forks are long enough to extend beyond opposite side of unit.

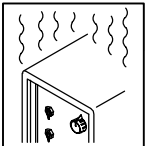

OVERUSE can cause OVERHEATING

- Allow cooling period; follow rated duty cycle.
- Reduce current or reduce duty cycle before starting to weld again.
- Do not block or filter airflow to unit.

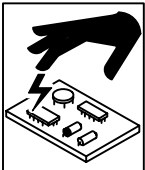

STATIC (ESD) can damage PC boards.

- Put on grounded wrist strap BEFORE handling boards or parts.
- Use proper static-proof bags and boxes to store, move, or ship PC boards.



MOVING PARTS can cause injury.

- Keep away from moving parts.
- Keep away from pinch points such as drive rolls.



WELDING WIRE can cause injury.

- Do not press gun trigger until instructed to do so.
- Do not point gun toward any part of the body, other people, or any metal when threading welding wire.

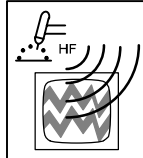

H.F. RADIATION can cause interference.

- High-frequency (H.F.) can interfere with radio navigation, safety services, computers, and communications equipment.
- Have only qualified persons familiar with electronic equipment perform this installation.
- The user is responsible for having a qualified electrician promptly correct any interference problem resulting from the installation.
- If notified by the FCC about interference, stop using the equipment at once.
- Have the installation regularly checked and maintained.
- Keep high-frequency source doors and panels tightly shut, keep spark gaps at correct setting, and use grounding and shielding to minimize the possibility of interference.

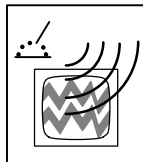

ARC WELDING can cause interference.

- Electromagnetic energy can interfere with sensitive electronic equipment such as computers and computer-driven equipment such as robots.
- Be sure all equipment in the welding area is electromagnetically compatible.
- To reduce possible interference, keep weld cables as short as possible, close together, and down low, such as on the floor.
- Locate welding operation 100 meters from any sensitive electronic equipment.
- Be sure this welding machine is installed and grounded according to this manual.
- If interference still occurs, the user must take extra measures such as moving the welding machine, using shielded cables, using line filters, or shielding the work area.

1-4. California Proposition 65 Warnings

- ▲ Welding or cutting equipment produces fumes or gases which contain chemicals known to the State of California to cause birth defects and, in some cases, cancer. (California Health & Safety Code Section 25249.5 et seq.)
- ▲ Battery posts, terminals and related accessories contain lead and lead compounds, chemicals known to the State of California to cause cancer and birth defects or other reproductive harm. Wash hands after handling.

For Gasoline Engines:

- ▲ Engine exhaust contains chemicals known to the State of California to cause cancer, birth defects, or other reproductive harm.

For Diesel Engines:

- ▲ Diesel engine exhaust and some of its constituents are known to the State of California to cause cancer, birth defects, and other reproductive harm.

1-5. Principal Safety Standards

Safety in Welding, Cutting, and Allied Processes, ANSI Standard Z49.1, from American Welding Society, 550 N.W. LeJeune Rd, Miami FL 33126 (phone: 305-443-9353, website: www.aws.org).

Recommended Safe Practices for the Preparation for Welding and Cutting of Containers and Piping, American Welding Society Standard AWS F4.1, from American Welding Society, 550 N.W. LeJeune Rd, Miami, FL 33126 (phone: 305-443-9353, website: www.aws.org).

National Electrical Code, NFPA Standard 70, from National Fire Protection Association, P.O. Box 9101, 1 Battery March Park, Quincy, MA 02269-9101 (phone: 617-770-3000, website: www.nfpa.org and www.sparky.org).

Safe Handling of Compressed Gases in Cylinders, CGA Pamphlet P-1, from Compressed Gas Association, 1735 Jefferson Davis Highway, Suite 1004, Arlington, VA 22202-4102 (phone: 703-412-0900, website: www.cganet.com).

Code for Safety in Welding and Cutting, CSA Standard W117.2, from Canadian Standards Association, Standards Sales, 178 Rexdale

Boulevard, Rexdale, Ontario, Canada M9W 1R3 (phone: 800-463-6727 or in Toronto 416-747-4044, website: www.csa-international.org).

Practice For Occupational And Educational Eye And Face Protection, ANSI Standard Z87.1, from American National Standards Institute, 11 West 42nd Street, New York, NY 10036-8002 (phone: 212-642-4900, website: www.ansi.org).

Standard for Fire Prevention During Welding, Cutting, and Other Hot Work, NFPA Standard 51B, from National Fire Protection Association, P.O. Box 9101, 1 Battery March Park, Quincy, MA 02269-9101 (phone: 617-770-3000, website: www.nfpa.org and www.sparky.org).

OSHA, Occupational Safety and Health Standards for General Industry, Title 29, Code of Federal Regulations (CFR), Part 1910, Subpart Q, and Part 1926, Subpart J, from U.S. Government Printing Office, Superintendent of Documents, P.O. Box 371954, Pittsburgh, PA 15250 (there are 10 Regional Offices—phone for Region 5, Chicago, is 312-353-2220, website: www.osha.gov).

1-6. EMF Information

Considerations About Welding And The Effects Of Low Frequency Electric And Magnetic Fields

Welding current, as it flows through welding cables, will cause electromagnetic fields. There has been and still is some concern about such fields. However, after examining more than 500 studies spanning 17 years of research, a special blue ribbon committee of the National Research Council concluded that: "The body of evidence, in the committee's judgment, has not demonstrated that exposure to power-frequency electric and magnetic fields is a human-health hazard." However, studies are still going forth and evidence continues to be examined. Until the final conclusions of the research are reached, you may wish to minimize your exposure to electromagnetic fields when welding or cutting.

To reduce magnetic fields in the workplace, use the following procedures:

1. Keep cables close together by twisting or taping them.
2. Arrange cables to one side and away from the operator.
3. Do not coil or drape cables around your body.
4. Keep welding power source and cables as far away from operator as practical.
5. Connect work clamp to workpiece as close to the weld as possible.

About Pacemakers:

Pacemaker wearers consult your doctor first. If cleared by your doctor, then following the above procedures is recommended.

SECTION 2 – CONSIGNES DE SÉCURITÉ – À LIRE AVANT UTILISATION

som_fre 8/03

2-1. Signification des symboles



Signifie « Mise en garde. Faire preuve de vigilance. » Cette procédure présente des risques identifiés par les symboles adjacents aux directives.

▲ Identifie un message de sécurité particulier.

☞ Signifie « NOTA » ; n'est pas relatif à la sécurité.



Ce groupe de symboles signifie « Mise en garde. Faire preuve de vigilance. » Il y a des dangers liés aux CHOCS ÉLECTRIQUES, aux PIÈCES EN MOUVEMENT et aux PIÈCES CHAUDES. Se reporter aux symboles et aux directives ci-dessous afin de connaître les mesures à prendre pour éviter tout danger.

2-2. Dangers relatifs au soudage à l'arc

▲ Les symboles ci-après sont utilisés tout au long du présent manuel pour attirer l'attention sur les dangers potentiels et les identifier. Lorsqu'on voit un symbole, faire preuve de vigilance et suivre les directives mentionnées afin d'éviter tout danger. Les consignes de sécurité énoncées ci-après ne font que résumer le contenu des normes de sécurité mentionnées à la section 2-4. Lire et respecter toutes ces normes.

▲ L'installation, l'utilisation, l'entretien et les réparations ne doivent être confiés qu'à des personnes qualifiées.

▲ Pendant l'utilisation de l'appareil, tenir à l'écart toute personne, en particulier les enfants.



LES DÉCHARGES ÉLECTRIQUES peuvent être mortelles.

Un simple contact avec des pièces sous tension peut causer une électrocution ou des blessures graves. L'électrode et le circuit de soudage sont sous tension dès que l'appareil est en fonctionnement. Le circuit d'entrée et les circuits internes de l'appareil sont également sous tension. En soudage semi-automatique ou automatique, le fil, le dévidoir, le logement des galets d'entraînement et les pièces métalliques en contact avec le fil de soudage sont sous tension. Tout matériel mal installé ou mal mis à la terre présente un danger.

- Ne jamais toucher aux pièces électriques sous tension.
- Porter des gants et des vêtements de protection secs et exempts de trous.
- S'isoler de la pièce et de la terre au moyen de tapis ou autres dispositifs isolants suffisamment grands pour empêcher tout contact physique avec la pièce ou la terre.
- Ne pas se servir d'une source de courant alternatif dans les zones humides, les endroits confinés ou là où on risque de tomber.
- Ne se servir d'une source de courant alternatif QUE si le procédé de soudage l'exige.
- Si l'utilisation d'une source de courant alternatif s'avère nécessaire, se servir de la fonction de télécommande si l'appareil en est équipé.
- Couper l'alimentation ou arrêter le moteur avant de procéder à l'installation, à la réparation ou à l'entretien de l'appareil. Couper/étiqueter l'alimentation selon la norme OSHA 29 CFR 1910.147 (voir les normes de sécurité).
- Installer et mettre à la terre correctement l'appareil conformément à son manuel d'utilisation et aux codes nationaux, provinciaux et municipaux.
- Toujours vérifier la terre du cordon d'alimentation – Vérifier et s'assurer que le fil de terre du cordon d'alimentation est bien raccordé à la borne de terre du sectionneur ou que la fiche du cordon est raccordée à une prise correctement mise à la terre.
- Pour exécuter les branchements d'entrée, fixer d'abord le conducteur de mise à la terre adéquat et contre-vérifier les connexions.
- Vérifier fréquemment le cordon d'alimentation et s'assurer qu'il n'est ni endommagé ni dénudé ; le remplacer immédiatement s'il est endommagé – tout câble dénudé peut causer une électrocution.
- Mettre l'appareil hors tension quand on ne l'utilise pas.
- Ne pas utiliser de câbles usés, endommagés, de calibre insuffisant ou mal épissés.
- Ne pas s'enrouler les câbles autour du corps.
- Si la pièce soudée doit être mise à la terre, le faire directement avec un câble distinct.
- Ne pas toucher l'électrode quand on est en contact avec la pièce, la terre ou une électrode d'une autre machine.

- N'utiliser que du matériel en bon état. Réparer ou remplacer sur-le-champ les pièces endommagées. Entretien l'appareil conformément au présent manuel.
- Porter un harnais de sécurité quand on travaille en hauteur.
- Maintenir solidement en place tous les panneaux et capots.
- Fixer le câble de retour de façon à obtenir un bon contact métal sur métal avec la pièce à souder ou la table de travail, le plus près possible de la soudure.
- Ne pas connecter plus d'une électrode ou plus d'un câble de masse à un même terminal de sortie.

Il subsiste un COURANT CONTINU IMPORTANT dans les convertisseurs après la suppression de l'alimentation électrique.

- Arrêter les convertisseurs, débrancher le courant électrique et décharger les condensateurs d'alimentation selon les instructions énoncées à la section Entretien avant de toucher les pièces.

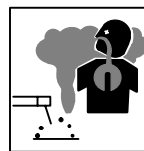

LES FUMÉES ET LES GAZ peuvent être dangereux.

Le soudage génère des fumées et des gaz dont l'inhalation peut être dangereuse pour la santé.

- Se tenir à distance des fumées et ne pas les inhaler.
- À l'intérieur, ventiler la zone et/ou utiliser un dispositif d'aspiration au niveau de l'arc pour l'évacuation des fumées et des gaz de soudage.
- Si la ventilation est insuffisante, utiliser un respirateur à adduction d'air agréé.
- Lire les fiches techniques de santé-sécurité (FTSS) et les instructions du fabricant concernant les métaux, les consommables, les revêtements, les nettoyeurs et les dégraissateurs.
- Ne travailler dans un espace clos que s'il est bien ventilé ou porter un respirateur à adduction d'air. Demander toujours à un surveillant dûment formé de se tenir à proximité. Des fumées et des gaz de soudage peuvent se substituer à l'air, abaisser la teneur en oxygène et causer des lésions ou des accidents mortels. S'assurer que l'air est respirable.
- Ne pas souder à proximité d'opérations de dégraissage, de nettoyage ou de pulvérisation. La chaleur et les rayons de l'arc peuvent réagir en présence de vapeurs et former des gaz hautement toxiques et irritants.
- Ne pas souder de métaux munis d'un revêtement, tels que la tôle d'acier galvanisée, plombée ou cadmiée, à moins que le revêtement n'ait été enlevé dans la zone de soudage, que l'endroit soit bien ventilé, et si nécessaire, porter un respirateur à adduction d'air. Les revêtements et tous les métaux renfermant ces éléments peuvent dégager des fumées toxiques lorsqu'on les soude.



LES RAYONS DE L'ARC peuvent causer des brûlures oculaires et cutanées.

Le rayonnement de l'arc génère des rayons visibles et invisibles intenses (ultraviolets et infrarouges) susceptibles de causer des brûlures oculaires et cutanées. Des étincelles sont projetées pendant le soudage.

- Porter un masque de soudage muni d'un filtre de la nuance adéquate pour se protéger le visage et les yeux pendant le soudage ou pour regarder (voir les normes de sécurité ANSI Z49.1 et Z87.1).
- Porter des lunettes de sécurité à écrans latéraux sous le masque.
- Utiliser des écrans ou des barrières pour protéger les tiers de l'éclat éblouissant ou aveuglant de l'arc ; leur demander de ne pas regarder l'arc.
- Porter des vêtements de protection en matière durable et ignifuge (cuir ou laine) et des chaussures de sécurité.



LE SOUDAGE peut causer un incendie ou une explosion.

Le soudage effectué sur des récipients fermés tels que des réservoirs, des fûts ou des conduites peut causer leur éclatement. Des étincelles peuvent être projetées de l'arc de soudure. La projection d'étincelles, les pièces chaudes et les équipements chauds peuvent causer des incendies et des brûlures. Le contact accidentel de l'électrode avec tout objet métallique peut causer des étincelles, une explosion, un surchauffement ou un incendie. Avant de commencer le soudage, vérifier et s'assurer que l'endroit ne présente pas de danger.

- Se protéger et protéger les tiers de la projection d'étincelles et de métal chaud.
- Ne pas souder à un endroit où des étincelles peuvent tomber sur des substances inflammables.
- Placer toutes les substances inflammables à une distance de 10,7 m de l'arc de soudage. En cas d'impossibilité, les recouvrir soigneusement avec des protections agréées.
- Des étincelles et des matières en fusion peuvent facilement passer même par des fissures et des ouvertures de petites dimensions.
- Surveiller tout déclenchement d'incendie et tenir un extincteur à proximité.
- Le soudage effectué sur un plafond, un plancher, une paroi ou une cloison peut déclencher un incendie de l'autre côté.
- Ne pas souder des récipients fermés tels que des réservoirs, des fûts ou des conduites, à moins qu'ils n'aient été préparés conformément à l'AWS F4.1 (voir les normes de sécurité).
- Brancher le câble sur la pièce le plus près possible de la zone de soudage pour éviter que le courant ne circule sur une longue distance, par des chemins inconnus, et ne cause des risques d'électrocution et d'incendie.
- Ne pas utiliser le poste de soudage pour dégeler des conduites gelées.
- En cas de non utilisation, enlever la baguette d'électrode du porte-électrode ou couper le fil au raz du tube-contact.
- Porter des vêtements de protection exempts d'huile tels que des gants en cuir, une chemise en tissu épais, des pantalons sans revers, des chaussures montantes et un masque.
- Avant de souder, retirer tout produit combustible de ses poches, tel qu'un briquet au butane ou des allumettes.

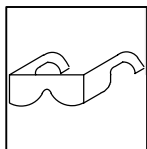

LES PARTICULES PROJETÉES peuvent blesser les yeux.

- Le soudage, le burinage, le passage de la pièce à la brosse métallique et le meulage provoquent l'émission d'étincelles et de particules métalliques. Pendant leur refroidissement, les soudures risquent de projeter du laitier.
 - Porter des lunettes de sécurité à écrans latéraux agréés, même sous le masque de soudage.



LES ACCUMULATIONS DE GAZ peuvent causer des blessures ou même la mort.

- Couper l'alimentation en gaz protecteur en cas de non utilisation.
- Veiller toujours à bien ventiler les espaces confinés ou porter un respirateur à adduction d'air agréé.



LES PIÈCES CHAUDES peuvent causer des brûlures graves.

- Ne pas toucher les pièces chaudes à main nue.
- Prévoir une période de refroidissement avant d'utiliser le pistolet ou la torche.

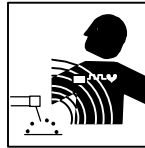

LES CHAMPS MAGNÉTIQUES peuvent perturber le fonctionnement des stimulateurs cardiaques.

- Les personnes qui portent un stimulateur cardiaque doivent se tenir à distance.
- Ils doivent consulter leur médecin avant de s'approcher d'un lieu où on exécute des opérations de soudage à l'arc, de gougeage ou de soudage par points.

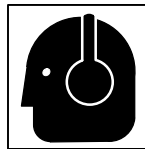

LE BRUIT peut affecter l'ouïe.

Le bruit de certains processus et équipements peut affecter l'ouïe.

- Porter des protecteurs d'oreille agréés si le niveau sonore est trop élevé.

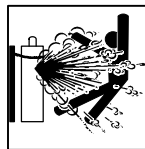

Les BOUTEILLES endommagées peuvent exploser.

Les bouteilles de gaz protecteur contiennent du gaz sous haute pression. Toute bouteille endommagée peut exploser. Comme les bouteilles de gaz font normalement partie du procédé de soudage, les manipuler avec précaution.

- Protéger les bouteilles de gaz comprimé de la chaleur excessive, des chocs mécaniques, du laitier, des flammes nues, des étincelles et des arcs.
- Placer les bouteilles debout en les fixant dans un support stationnaire ou dans un porte-bouteilles pour les empêcher de tomber ou de se renverser.
- Tenir les bouteilles éloignées des circuits de soudage ou autres circuits électriques.
- Ne jamais poser une torche de soudage sur une bouteille de gaz.
- Ne jamais mettre une électrode de soudage en contact avec une bouteille de gaz.
- Ne jamais souder une bouteille contenant du gaz sous pression – elle risquerait d'exploser.
- N'utiliser que les bouteilles de gaz protecteur, régulateurs, tuyaux et raccords adéquats pour l'application envisagée ; les maintenir en bon état, ainsi que les pièces connexes.
- Détourner la tête lorsqu'on ouvre la soupape d'une bouteille.
- Laisser le capuchon protecteur sur la soupape, sauf en cas d'utilisation ou de branchement de la bouteille
- Lire et suivre les instructions concernant les bouteilles de gaz comprimé, les équipements associés et les publications P-1 de la CGA, mentionnées dans les normes de sécurité.

2-3. Autres symboles relatifs à l'installation, au fonctionnement et à l'entretien de l'appareil.



Risque D'INCENDIE OU D'EXPLOSION

- Ne pas placer l'appareil sur une surface inflammable, ni au-dessus ou à proximité d'elle.
- Ne pas installer l'appareil à proximité de produits inflammables.
- Ne pas surcharger l'installation électrique – s'assurer que l'alimentation est correctement dimensionnée et protégée avant de mettre l'appareil en service.



LA CHUTE DE L'APPAREIL peut blesser.

- N'utiliser que l'anneau de levage pour lever l'appareil. NE PAS utiliser le chariot, les bouteilles de gaz ou tout autre accessoire.
- Utiliser un engin de capacité adéquate pour lever l'appareil.
- Si on utilise un chariot élévateur pour déplacer l'unité, s'assurer que les fourches sont suffisamment longues pour dépasser du côté opposé de l'appareil.

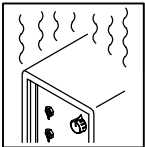

L'EMPLOI EXCESSIF peut FAIRE SURCHAUFFER L'ÉQUIPEMENT.

- Prévoir une période de refroidissement ; respecter le cycle opératoire nominal.
- Réduire le courant ou le cycle opératoire avant de reprendre le soudage.
- Ne pas obstruer les orifices ou filtrer l'alimentation en air du poste.

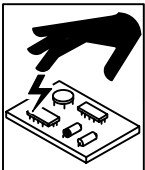

LES CHARGES ÉLECTROSTATIQUES peuvent endommager les circuits imprimés.

- Mettre un bracelet antistatique AVANT de manipuler des cartes ou des pièces.
- Utiliser des pochettes et des boîtes antistatiques pour stocker, déplacer ou expédier des cartes de circuits imprimés.



LES PIÈCES MOBILES peuvent causer des blessures.

- Se tenir à l'écart des pièces mobiles.
- Se tenir à l'écart des points de coincement tels que les dévidoirs.



LES FILS DE SOUDAGE peuvent causer des blessures.

- Ne pas appuyer sur la gâchette avant d'en avoir reçu l'instruction.
- Ne pas diriger le pistolet vers soi, vers d'autres personnes ou vers toute pièce mécanique en engageant le fil de soudage.



LES ORGANES MOBILES peuvent causer des blessures.

- Se tenir à l'écart des organes mobiles comme les ventilateurs.
- Maintenir fermés et bien fixés les portes, panneaux, recouvrements et dispositifs de protection.

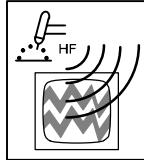

LE RAYONNEMENT HAUTE FRÉQUENCE (H. F.) risque de causer des interférences.

- Le rayonnement haute fréquence peut causer des interférences avec les équipements de radio-navigation et de communication, les services de sécurité et les ordinateurs.
- Ne demander qu'à des personnes qualifiées familiarisées avec les équipements électroniques de faire fonctionner l'installation.
- L'utilisateur est tenu de faire corriger rapidement par un électricien qualifié les interférences causées par l'installation.
- Si la Federal Communications Commission signale des interférences, arrêter immédiatement l'appareil.
- Faire régulièrement contrôler et entretenir l'installation.
- Maintenir soigneusement fermés les panneaux et les portes des sources de haute fréquence, maintenir le jeu d'éclatement au réglage adéquat et utiliser une terre et un blindage pour réduire les interférences éventuelles.

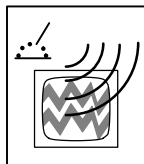

LE SOUDAGE À L'ARC peut causer des interférences.

- L'énergie électromagnétique peut causer des interférences avec l'équipement électronique sensible tel que les ordinateurs et l'équipement commandé par ordinateur tel que les robots.
- Veiller à ce que tout l'équipement de la zone de soudage soit compatible au point de vue électromagnétique.
- Pour réduire la possibilité d'interférence, maintenir les câbles de soudage aussi courts que possible, les grouper, et les poser aussi bas que possible (par ex. : à terre).
- Veiller à souder à une distance de 100 mètres de tout équipement électronique sensible.
- Veiller à ce que le poste de soudage soit posé et mis à la terre conformément au présent manuel.
- En cas d'interférences après exécution des directives précédentes, il incombe à l'utilisateur de prendre des mesures supplémentaires telles que le déplacement du poste, l'utilisation de câbles blindés, l'utilisation de filtres de ligne ou la pose de protecteurs dans la zone de travail.

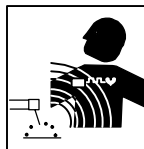

LES CHAMPS MAGNÉTIQUES peuvent affecter les stimulateurs cardiaques.

- Porteurs de stimulateur cardiaque, restez à distance.
- Les porteurs d'un stimulateur cardiaque doivent d'abord consulter leur médecin avant de s'approcher des opérations de soudage à l'arc, de gougeage ou de soudage par points.

2-4. Principales normes de sécurité

Safety in Welding, Cutting, and Allied Processes, norme ANSI Z49.1, de l'American Welding Society, 550 N.W. LeJeune Rd, Miami FL 33126 (téléphone : (305) 443-9353, site Web : www.aws.org).

Recommended Safe Practices for the Preparation for Welding and Cutting of Containers and Piping, norme American Welding Society AWS F4.1, de l'American Welding Society, 550 N.W. LeJeune Rd, Miami, FL 33126 (téléphone : (305) 443-9353, site Web : www.aws.org).

National Electrical Code, norme NFPA 70, de la National Fire Protection Association, P.O. Box 9101, 1 Battery March Park, Quincy, MA 02269-9101 (téléphone : (617) 770-3000, sites Web : www.nfpa.org et www.sparky.org).

Safe Handling of Compressed Gases in Cylinders, brochure CGA P-1, de la Compressed Gas Association, 1735 Jefferson Davis Highway, Suite 1004, Arlington, VA 22202-4102 (téléphone : (703) 412-0900, site Web : www.cganet.com).

Code for Safety in Welding and Cutting, norme CSA W117.2, de la Canadian Standards Association, Standards Sales, 178 boulevard

Rexdale, Rexdale (Ontario) Canada M9W 1R3 (téléphone : (800) 463-6727 ou à Toronto : (416) 747-4044, site Web : www.csa-international.org).

Practice For Occupational And Educational Eye And Face Protection, norme ANSI Z87.1, de l'American National Standards Institute, 11 West 42nd Street, New York, NY 10036-8002 (téléphone : (212) 642-4900, site Web : www.ansi.org).

Standard for Fire Prevention During Welding, Cutting, and Other Hot Work, norme NFPA 51B, de la National Fire Protection Association, P.O. Box 9101, 1 Battery March Park, Quincy, MA 02269-9101 (téléphone : (617) 770-3000, site Web : www.nfpa.org et www.sparky.org).

OSHA, Occupational Safety and Health Standards for General Industry, Title 29, Code of Federal Regulations (CFR), Part 1910, Subpart Q, and Part 1926, Subpart J, de l'U.S. Government Printing Office, Superintendent of Documents, P.O. Box 371954, Pittsburgh, PA 15250 (il y a 10 bureaux régionaux – Téléphone pour la Région 5, Chicago : (312) 353-2220, site Web : www.osha.gov).

2-5. Information sur les champs électromagnétiques

Données sur le soudage électrique et les effets des champs magnétiques basse fréquence sur l'organisme

En parcourant les câbles de soudage, le courant crée des champs électromagnétiques. Les effets potentiels de tels champs restent préoccupants. Cependant, après avoir examiné plus de 500 études qui ont été faites pendant une période de recherche de 17 ans, un comité de spécialistes du National Research Council a conclu : « L'accumulation de preuves n'a pas démontré que l'exposition aux champs magnétiques et aux champs électriques à haute fréquence constitue un risque pour la santé humaine ». Toutefois, les études et l'examen des preuves se poursuivent. En attendant les conclusions finales de la recherche, il serait souhaitable de réduire l'exposition aux champs électromagnétiques pendant le soudage ou le coupage.

Afin de réduire les champs électromagnétiques en milieu de travail, respecter les consignes suivantes :

1. Garder les câbles ensemble en les torsadant ou en les fixant avec du ruban adhésif.
2. Mettre tous les câbles du côté opposé à l'opérateur.
3. Ne pas s'enrouler les câbles autour du corps.
4. Garder le poste de soudage et les câbles le plus loin possible de soi.
5. Placer la pince de masse le plus près possible de la zone de soudage.

Consignes relatives aux stimulateurs cardiaques :

Les personnes qui portent un stimulateur cardiaque doivent avant tout consulter leur médecin. Si ce dernier les déclare aptes, il leur est recommandé de respecter les consignes ci-dessus.

SECTION 3 – INTRODUCTION



3-1. Specifications

Type of Input Power	Welding Power Source Type	Wire Feed Speed Range	Wire Diameter Range	Welding Circuit Rating	Weight
24 Volts AC Single-Phase 10 Amperes 50/60 Hertz	Constant Voltage (CV) DC With 14-Pin And Contactor Control	Standard: 50 To 780 ipm (1.3 To 19.8 mpm) Optional High Speed: 92 To 1435 ipm (2.3 To 36.5 mpm)	.023 To 1/8 in (0.6 To 3.2 mm) Max Spool Weight: 60 lb (27 kg)	100 Volts, 750 Amperes, 100% Duty Cycle	12 ft (3.7 m): 207 lb (94 kg) 16 ft (4.9 m): 280 lb (127 kg)

	12 ft (3.7 m) Boom	16 ft (4.9 m) Boom
Maximum Height With 4 ft (1.2 m) Post	17 ft (5.2 m)	21 ft (6.4 m)
Vertical Lift Of Boom	Horizontal to 60° Above Horizontal	Horizontal to 60° Above Horizontal

SECTION 4 – INSTALLATION

4-1. Installing Swivel Into Pipe Post

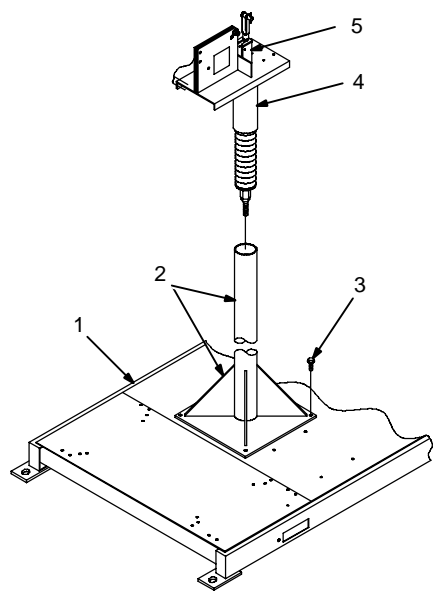

▲ Do not remove Safety Collar until instructed to.

- 1 Swingpak Base or CBC Cart
- 2 Pipe Post With Base
- 3 Steel Bolt

Secure as shown using as a minimum 1/2 in diameter SAE grade 5 steel bolts.

- 4 Swivel Assembly

Insert into pipe post. Lubricate swivel.

- 5 Safety Collar

Tools Needed:

 3/4 in

152 268-B

4-2. Installing Control Box And Adjusting Tilt

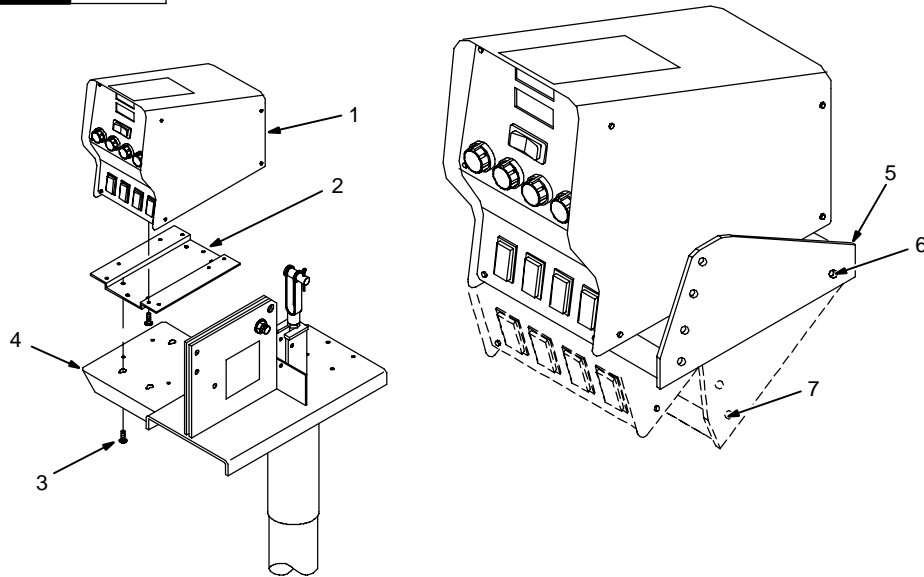

- 1 Weld Control
- 2 Bracket
- 3 Screw

Bracket and screws are installed onto bottom of control at factory.

- 4 Swivel

Loosen screws. Place control on swivel and slide forward. Tighten screws.

- 5 Tilt Bracket
- 6 Rear Pivot Screw
- 7 Front Screw

Loosen rear pivot screw. Remove front screw. Pivot control downward to desired viewing angle. Replace and tighten front screw. Tighten pivot screw.

Tools Needed:

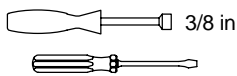

803 182

4-3. Installing Boom And Reel Support

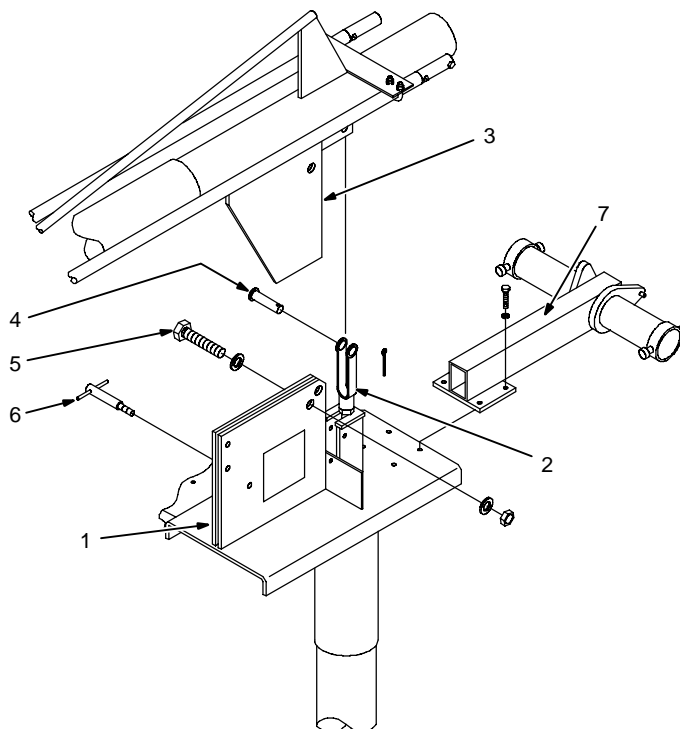

- 1 Swivel Plates
- 2 Yoke

Remove hardware from swivel plates and yoke.

- 3 Boom

Set boom into swivel as shown.

- 4 Yoke Pin

Install pin through yoke. Install cotter pin and spread ends.

- 5 Bolt

Install bolt, washers, and nut. Tighten hardware, and back bolt off one half turn.

- 6 Locking Knob

Install locking knob but do not tighten.

- 7 Reel Support

Install reel support.

Tools Needed:



ST-153 170-A

4-4. Installing Wire Guide Extension

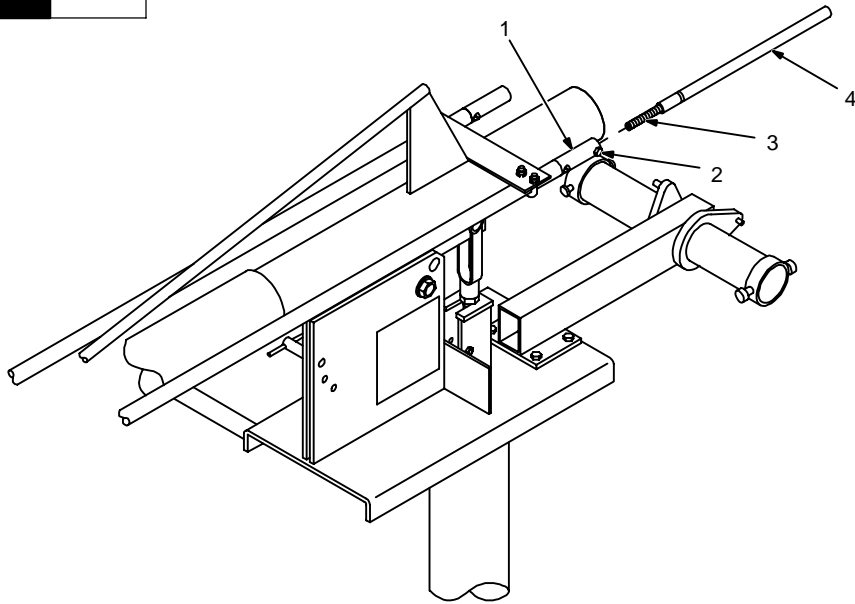

- 1 Wire Guide Fitting
- 2 Bolt
- 3 Monocoil Liner
- 4 Wire Guide Extension

Tighten bolt to secure liner in wire guide fitting. Do not overtighten bolt and crush liner.

Repeat procedure for opposite side.

Tools Needed:

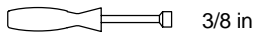

3/8 in

ST-152 383

4-5. Equipment Connection Diagram



- 1 Welding Power Source
- 2 Remote 14 Connection
- 3 Negative (-) Weld Output Cable
- 4 Positive (+) Weld Output Cable
- 5 Workpiece
- 6 Weld Control
- 7 Boom
- 8 Gun
- 9 Swivel
- 10 Pipe Post And Base
- 11 Gas Hose
- 12 Gas Supply

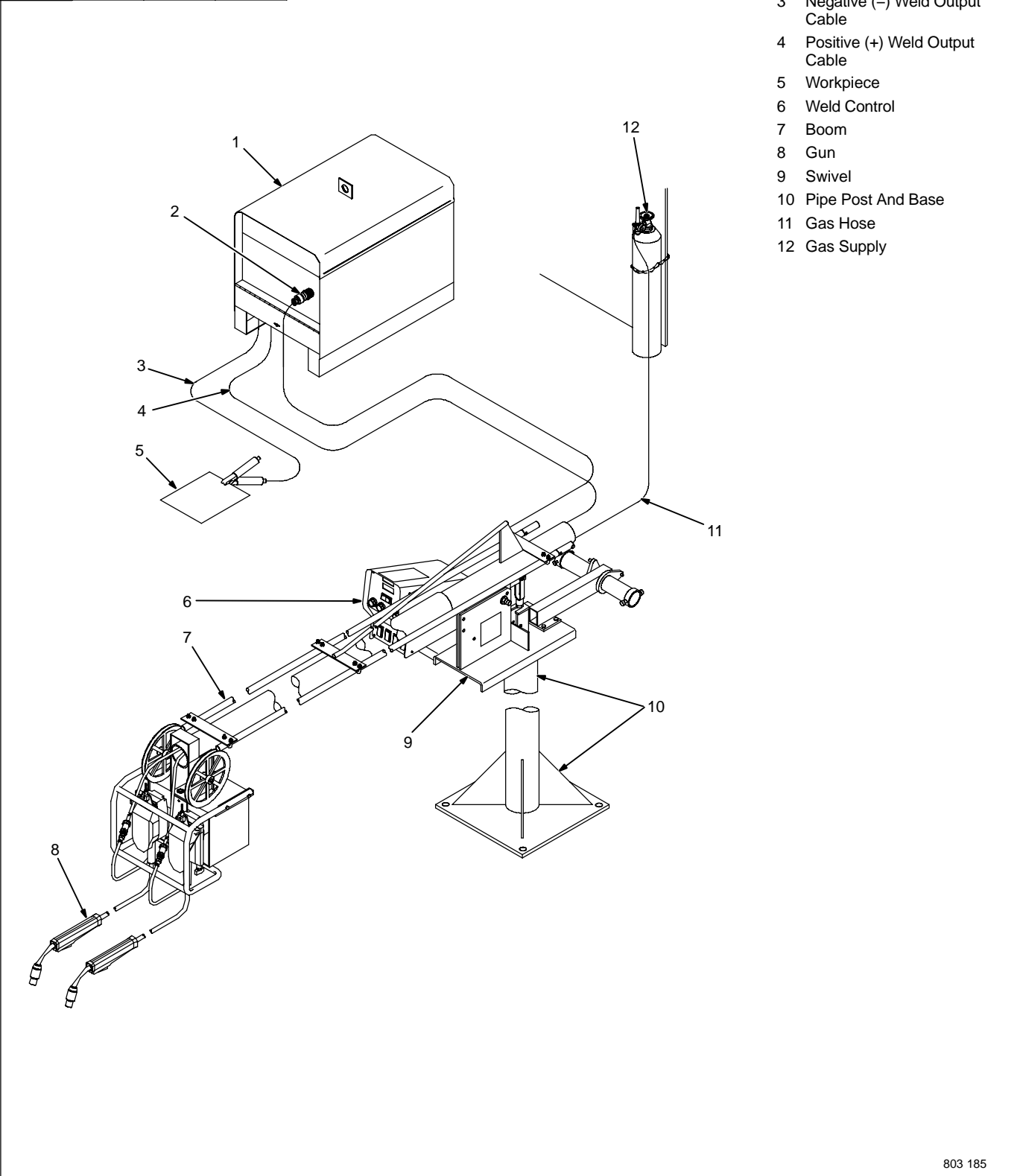

803 185

4-6. Control Box Connections

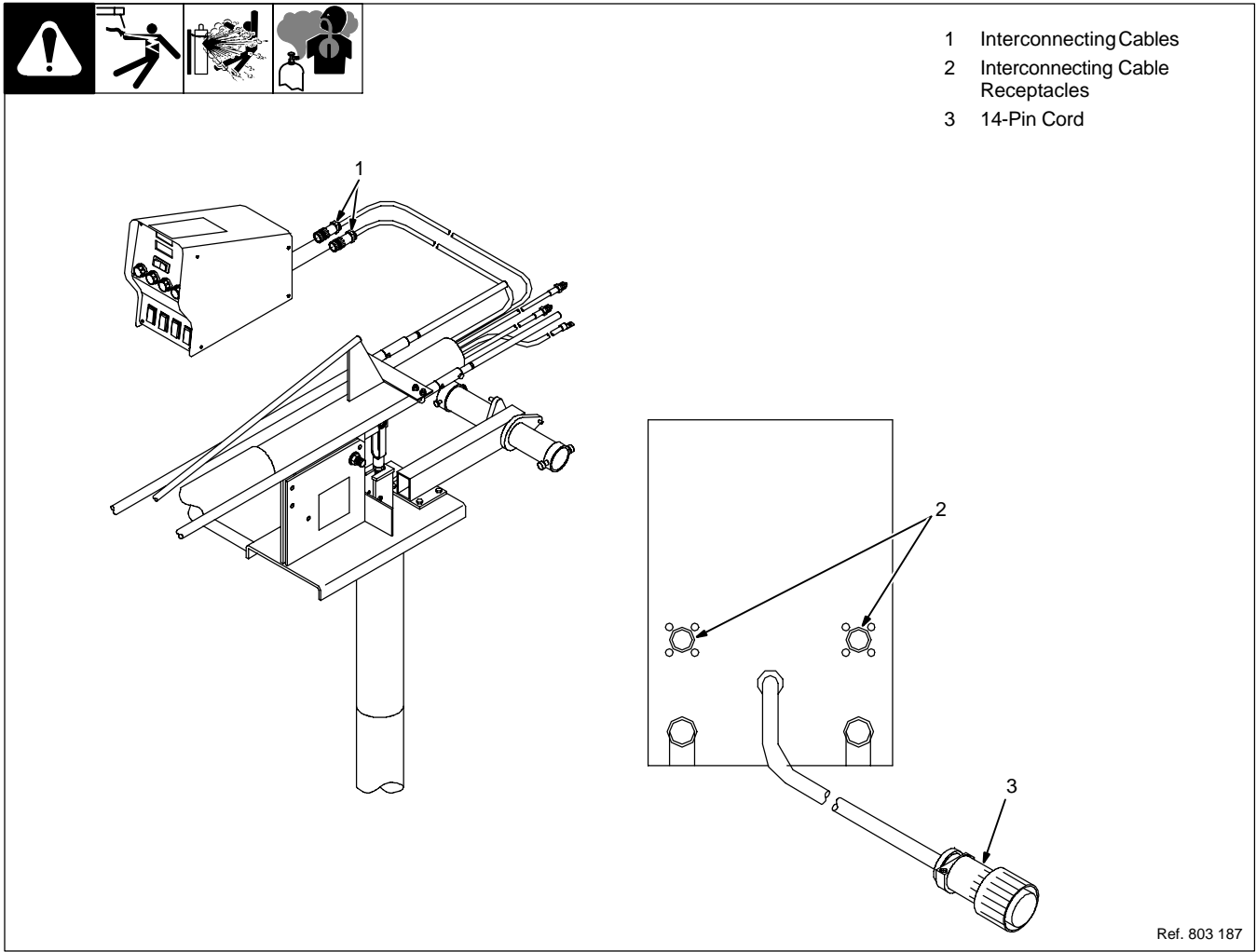

4-7. 14-Pin Plug Information

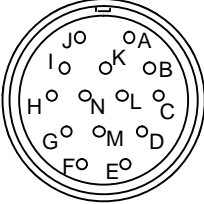
 REMOTE 14	Pin*	Pin Information
	A	24 volts ac with respect to socket G.
	B	Contact closure to A completes 24 volts ac contactor control circuit.
	G	Circuit common for 24 volts ac circuit.
	C	+10 volts dc input from power source to wire feeder with respect to socket D.
	D	Remote control circuit common.
	E	0 to +10 volts dc output signal from wire feeder to power source with respect to socket D.
	H	Voltage feedback; 0 to +10 volts dc, 1 volt per 10 arc volts.
	F	Current feedback; 0 to +10 volts dc, 1 volt per 100 amperes.

*The remaining pins are not used.

4-8. Removing Safety Collar And Adjusting Boom

1 Locking Knob
Tighten knob to prevent boom movement. Loosen knob to allow boom movement. Change knob position to limit upward movement.

Pull boom down slightly and remove safety collar. Boom should balance in any position from horizontal to 60 degrees above horizontal. If necessary, adjust boom as follows:

2 Threaded Rod
3 Jam Nut
Loosen jam nut and turn threaded rod until boom balances. Tighten jam nut. Be sure several full threads are through yoke to prevent boom falling.

4 Yoke
5 Safety Collar
Retain safety collar for use in disassembling or moving boom.

ST-142 599-C

4-9. Gun Recommendation Table

Process	Gun
GMAW – Hard or Cored Wires	Roughneck C-Series Guns: 300, 400, 500, And 600 Amp.
FCAW – Self-Shielding Wires	FC-1260 Or FC-1150

4-10. Wire Type, Size, And Feed Speed Capability Table

Motor Speed	Wire Type	Wire Size	Feed Speed Capability
Standard	All	.023 To 5/64 in (0.6 To 2 mm)	50 To 780 ipm (1.3 To 19.8 mpm)
Standard	All	3/32 To 7/64 in (2.4 To 2.8 mm)	50 To 700 ipm (1.3 To 17.8 mpm)
Standard	All	1/8 in (3.2 mm)	50 To 300 ipm (1.3 To 7.6 mpm)
Optional High Speed	All	.023 To 5/64 in (0.6 To 2 mm)	92 To 1435 ipm (2.3 To 36.4 mpm)

4-11. Installing And Threading Welding Wire

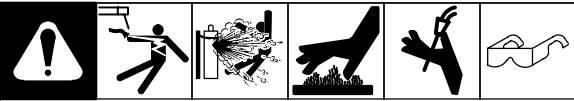

Tools Needed:

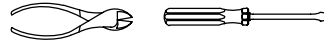

3/16, 5/64 in

3/8, 15/16 in

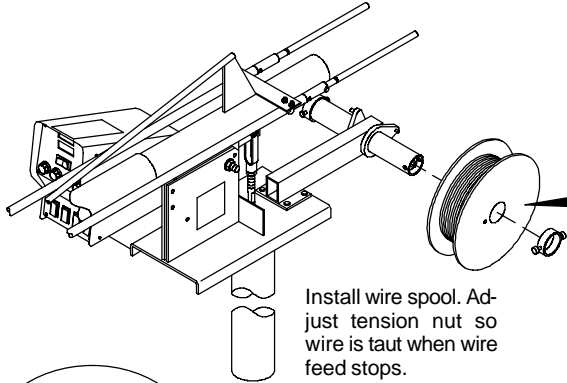

Install wire spool. Adjust tension nut so wire is taut when wire feed stops.

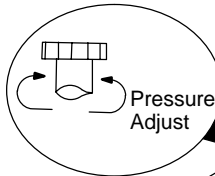
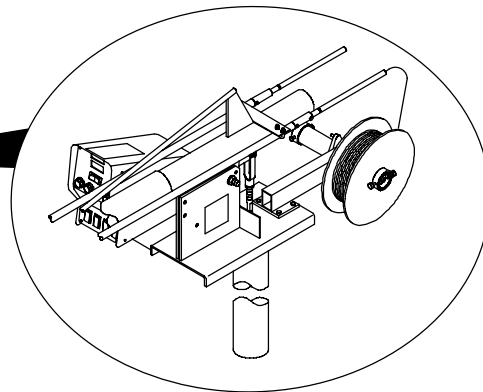

Pressure Adjust

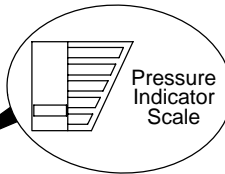

Pressure Indicator Scale

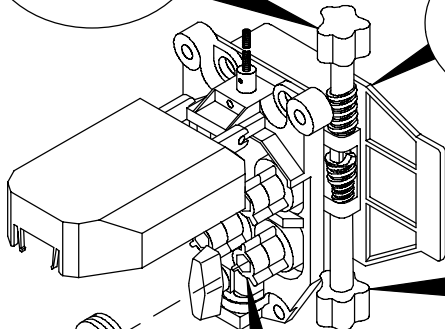

Install drive rolls.

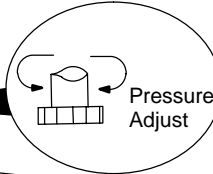

Pressure Adjust

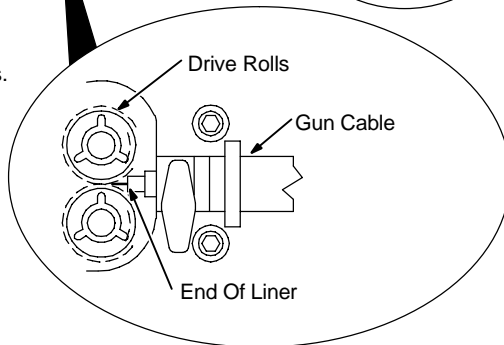

Drive Rolls

Gun Cable

End Of Liner

Install wire guide.

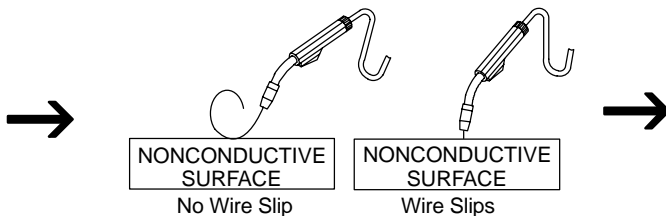
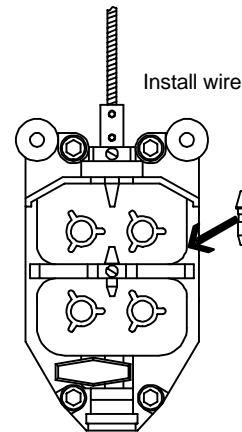

NONCONDUCTIVE SURFACE

No Wire Slip

NONCONDUCTIVE SURFACE

Wire Slips

☞ Be sure that outlet cable has proper size liner for the welding wire size.

When installing gun, position liner extending from outlet wire guide as close as possible to drive rolls without touching.

☞ For soft wire or small diameter stainless steel wire, reduce drive roll pressure on the rear roll to half that of the front rolls.

☞ To adjust drive roll pressure, hold nozzle about 2 in (51 mm) from nonconductive surface and press gun trigger to feed wire against surface. Tighten knob so wire does not slip. Do not overtighten. If contact tip is completely blocked, wire should slip at the feeder (see pressure adjustment above). Cut wire off. Close cover.

Install gun. Lay gun cable out straight. Cut off end of wire. Push wire through guides up to drive rolls; continue to hold wire. Press Jog button to feed wire out gun.

4-12. Setting Internal DIP Switches

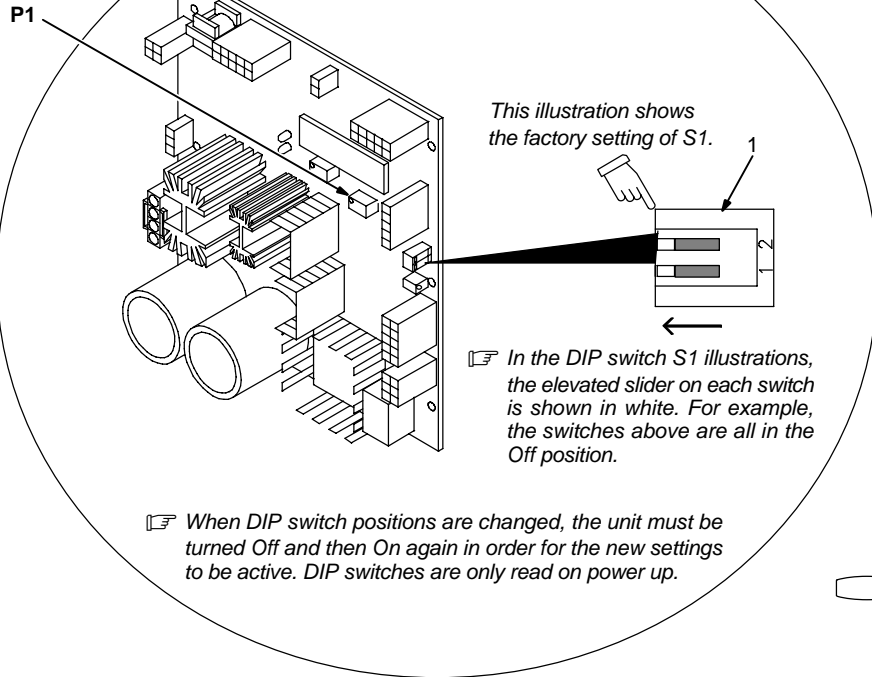
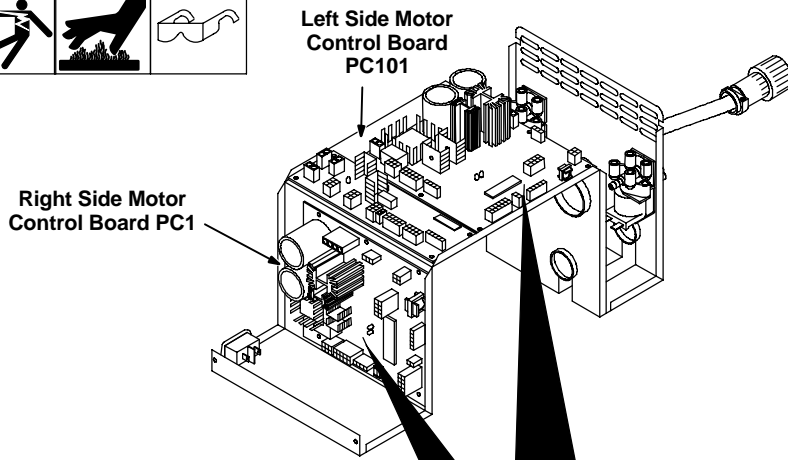

Remove wrapper.

1 DIP Switch S1 On Motor Board PC1

• Setting Current Detect Override (S1-1)

Current detect override is used to disable run-in when a welding power source is used that doesn't provide current feedback through the 14-pin receptacle.

Pins F & H are not present in 14 pin receptacle on machines that don't provide current feedback.

Install wrapper when finished.

Tools Needed:



Position Settings And Results For DIP Switch S1 On PC1 And PC101

Automatic Run-In (ON) (Factory Default)

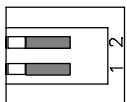

S1-1 And S1-2

On = Run-In speed is approximately 1/2 weld wire feed speed.

Automatic Run-In (OFF)

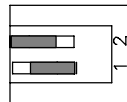

S1-1 And S1-2

Off = Run-In speed is set using potentiometer P1 located on Motor Board PC1.

Current Detect Override (ON)

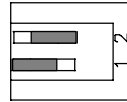

S1-1 And S1-2

On = Current detect override. For welding power sources that don't provide current feedback through the 14-pin receptacle. Run-in is inactive.

Current Detect Override (OFF) (Factory Default)

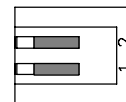

S1-1 And S1-2

Off = Current must be detected from power sources that provide current feedback through the 14-pin receptacle to go from run-in to welding condition. Run-in is active.

4-13. Optional Equipment DIP Switch Settings



Remove wrapper.

- 1 Digital Meter Board PC60
 - 2 Meter Board Switch S2
- Install wrapper when finished.

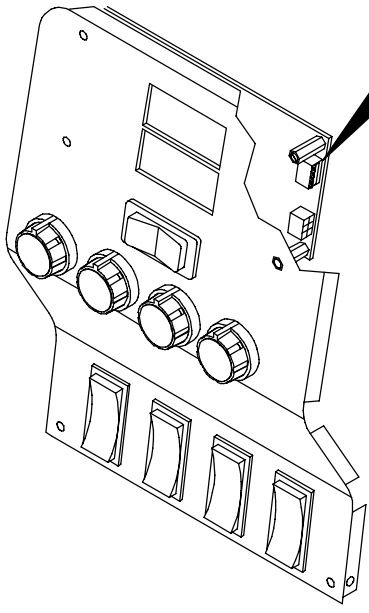
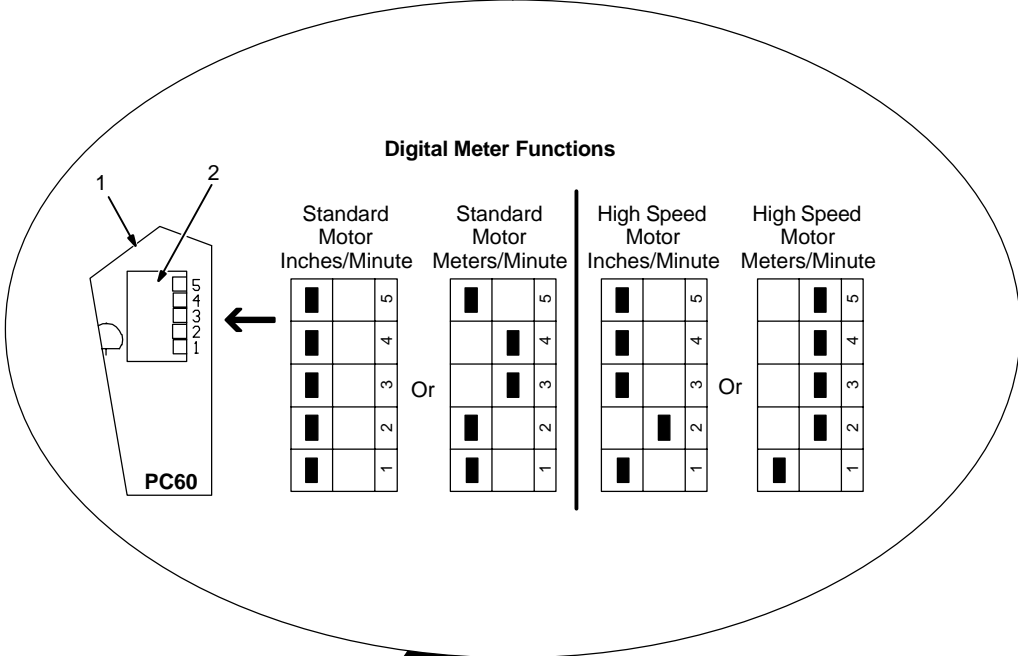

Tools Needed:

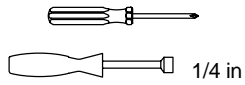

803 188

SECTION 5 – OPERATION

5-1. Power Switch

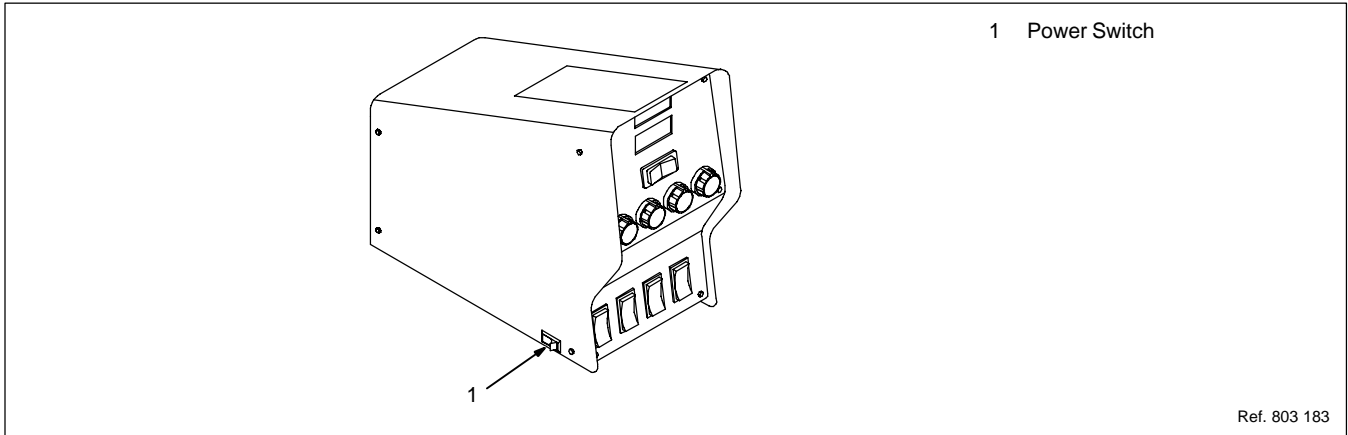

5-2. Left/Right Select Switch

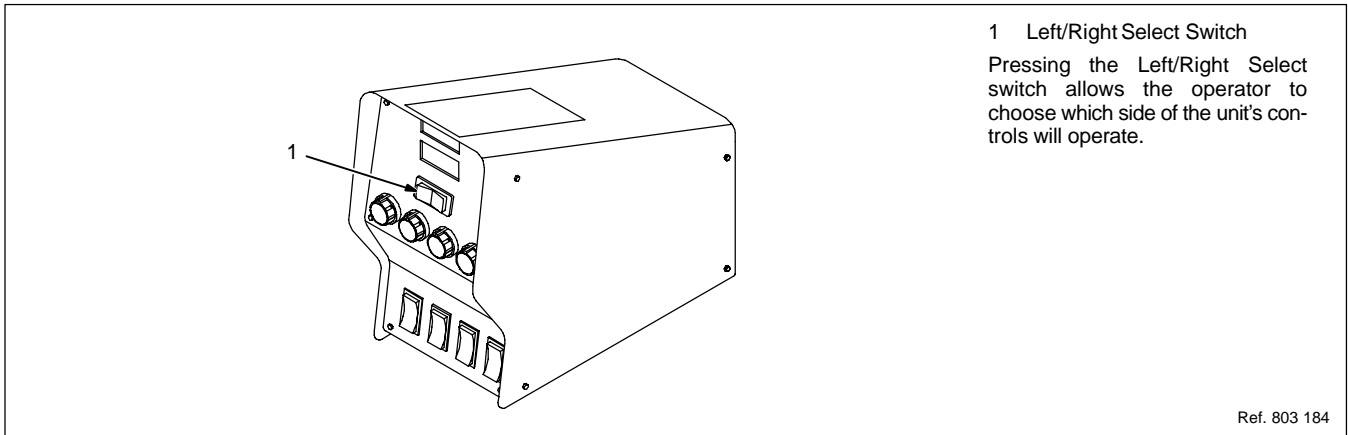

5-3. Jog/Purge

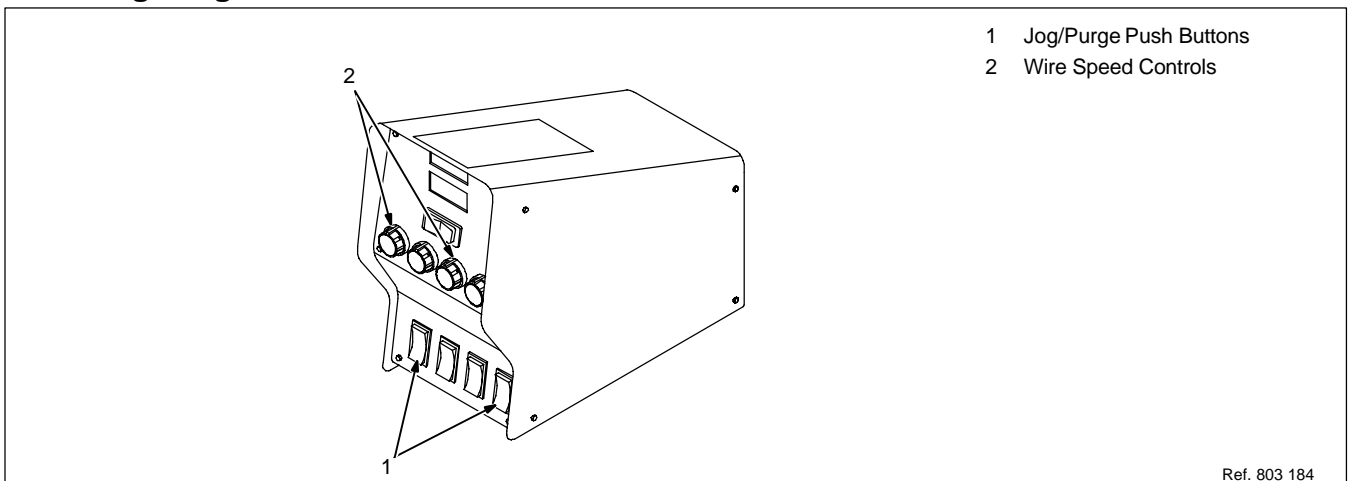

Pressing the Jog/Purge switch allows the operator to jog wire without energizing the weld power or gas valve circuit.

- The unit provides the ability to jog the wire feeder by means of the gun trigger or the Jog/Purge switch. If the welding arc does not initiate in 3 seconds after the gun trigger is activated, the unit will perform a jog operation for a maximum of two minutes. If the gun

trigger is still activated after two minutes, the jog operation is terminated to prevent complete despooling of the wire, in the case of a damaged gun.

- The unit displays the "ERR TRIG" message to inform the operator that the trigger is activated.
- Jog speed can be adjusted by the Adjust control when the unit is jogging wire. The

unit displays jog speed when the unit is being jogged.

- Jogging can also be accomplished by pressing the Jog/Purge button.
- Pressing the Jog/Purge button also allows the operator to purge gas lines before welding and to preset gas pressure at the regulator.

5-4. Trigger Hold Switch

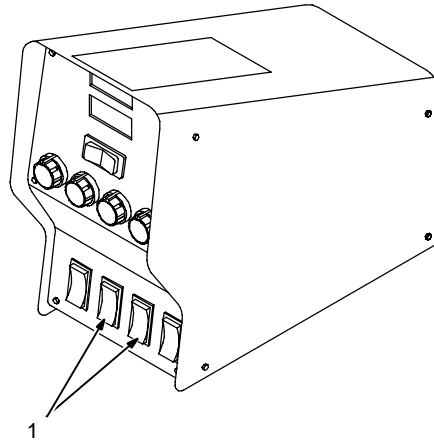

1 Trigger Hold Switches

Trigger hold allows the operator to weld without holding the gun trigger.

- To use the trigger hold function, place the trigger hold switch in the On position.
- The operator must hold the trigger for a minimum of 2 seconds, but not longer than 6 seconds before releasing it. Welding will continue when the trigger is released.
- To stop welding, press the trigger again.

Ref. 803 184

5-5. Voltage Control And Digital Meters

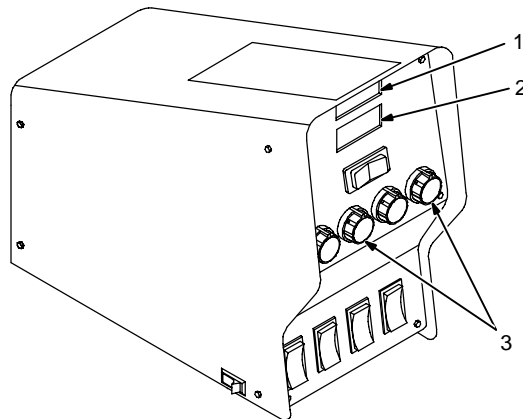

1 Voltmeter

Displays actual or preset voltage from welding power source through the 14-pin control cable.

2 Wire Speed Meter

Displays preset and actual wire feed speed while welding.

Factory set to display inches per minute. If display of meters per minute is desired, see Section 4-13.

3 Voltage Controls

Use controls to adjust voltage output of welding power source.

 You can adjust the preset voltage display on the wire feeder to match your power source's display by adjusting P2 on motor control board PC101 (left side), and/or P2 on motor control board PC1 (right side).

Ref. 803 183

SECTION 6 – MAINTENANCE & TROUBLESHOOTING

6-1. Routine Maintenance

					▲ Disconnect power before maintaining.
--	--	--	--	--	--

<div style="display: flex; justify-content: space-between; align-items: center;"> <div style="width: 15%;"></div> <div>3 Months</div> </div>							
Replace unreadable labels.			Clean and tighten weld terminals.		Repair or replace cracked weld cable.		
Replace cracked parts.		Check 14-pin cord.		Check gas hose and fittings.		Check gun cable.	
<div style="display: flex; justify-content: space-between; align-items: center;"> <div style="width: 15%;"></div> <div>6 Months</div> </div>							
Blow out or vacuum inside. During heavy service, clean monthly.		Or		Clean drive rolls.			

Notes

6-2. Diagnostics



- 1 LED3 On Right Side Motor Control Board PC1
- 2 LED3 On Left Side Motor Control Board PC101
- 3 LED3 On Dual Board PC70

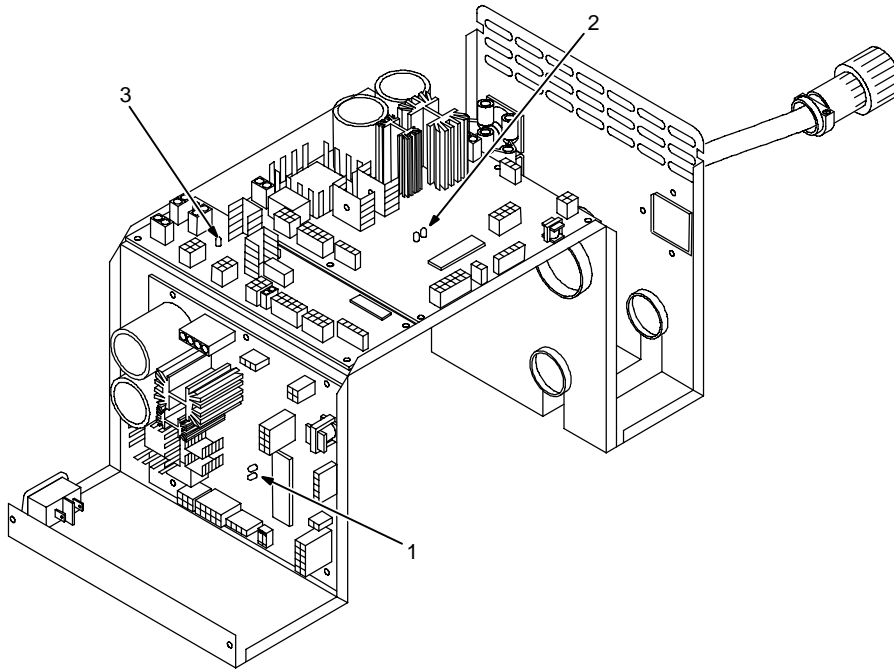

803 063-A

	Display On Optional Meter	LED3 Sequence	Indicated Error
Left Side Motor Control Board PC101	HELP 11	1 Blink	Communication Error
	HELP 12	2 Blinks	Trigger Error
	HELP 13	3 Blinks	Tach Error
	HELP 14	*4 Blinks	Motor Error
Right Side Motor Control Board PC1	HELP 21	1 Blink	Communication Error
	HELP 22	2 Blinks	Trigger Error
	HELP 23	3 Blinks	Tach Error
	HELP 24	*4 Blinks	Motor Error
Dual Board PC70	HELP 31	*4 Blinks	Communication Error
*Since blink On time and blink Off time are equal in a four-blink cycle, the four-blink sequence appears as constant blinking.			

• Error Indications

Error conditions are indicated by LED3 on PC1, PC101, PC70 or on display if meter option is present. To view LED3, turn Off unit, remove wrapper, and turn unit On. LED3 is most easily observed from the left side of the unit.

The LED blinks in a 2.5 second cycle. The number of blinks in this period indicates the type of error.

The priority of the errors is related to the number of blinks indicating the error. The more blinks, the more severe the error (motor error is top priority). A higher priority error overrides

a lower one (if a motor error and a communication error existed, the light would blink four times for the motor error).

- **The communication error** occurs 2.5 seconds after a loss of communication between the motor and the optional meter board or Dual board. The user may continue to weld with this error. The error may be cleared by turning power Off, waiting a minimum of two seconds, and turning power On.
- **The trigger error** occurs if the user has the trigger held for more than two minutes without striking an arc (providing current over-

ride is not enabled), or if the user holds the trigger past the postflow phase in a timed weld. This error also occurs if the trigger is held when the feeder is powered up. The error may be cleared by releasing the trigger.

- **The tach error** occurs 2 seconds after the loss of tachometer feedback. The user may continue to weld with this error. The motor speed is regulated through the monitoring of voltage and current.
- **The motor error** indicates that the motor has been drawing too much current for too long.

6-3. Troubleshooting



Trouble	Remedy
Wire feeds, shielding gas flows, but electrode wire is not energized.	Check cable connections. Check cables for continuity, and repair or replace cables if necessary (see Section 4-5).
Wire feeder is on, display does not light up, motor does not run, gas valve and welding power source contactor do not pull in.	Check and reset circuit breaker at welding power source.
Electrode wire feeding stops or feeds erratically during welding.	Check gun trigger connection. See gun Owner's Manual.
	Check gun trigger. See gun Owner's Manual.
	Readjust hub tension and drive roll pressure (see Section 4-11).
	Change to correct size drive roll (see Table 8-1).
	Clean or replace dirty or worn drive roll.
	Incorrect size or worn wire guides.
	Replace contact tip or liner. See gun Owner's Manual.
	Remove weld spatter or foreign matter from around nozzle opening.
Have Factory Authorized Service Agency check drive motor or motor control board PC1.	
Wire birdnests between feeder and gun.	Gun liner has to large of diameter opening, is clogged, or the end of the gun is not close enough to the front set of drive rolls.
Motor runs slowly.	Check for correct input voltage.
Wire feeder power is on, displays light up, but unit is inoperative.	Check welding gun trigger leads for continuity, and repair leads or replace gun.

SECTION 7 - ELECTRICAL DIAGRAM

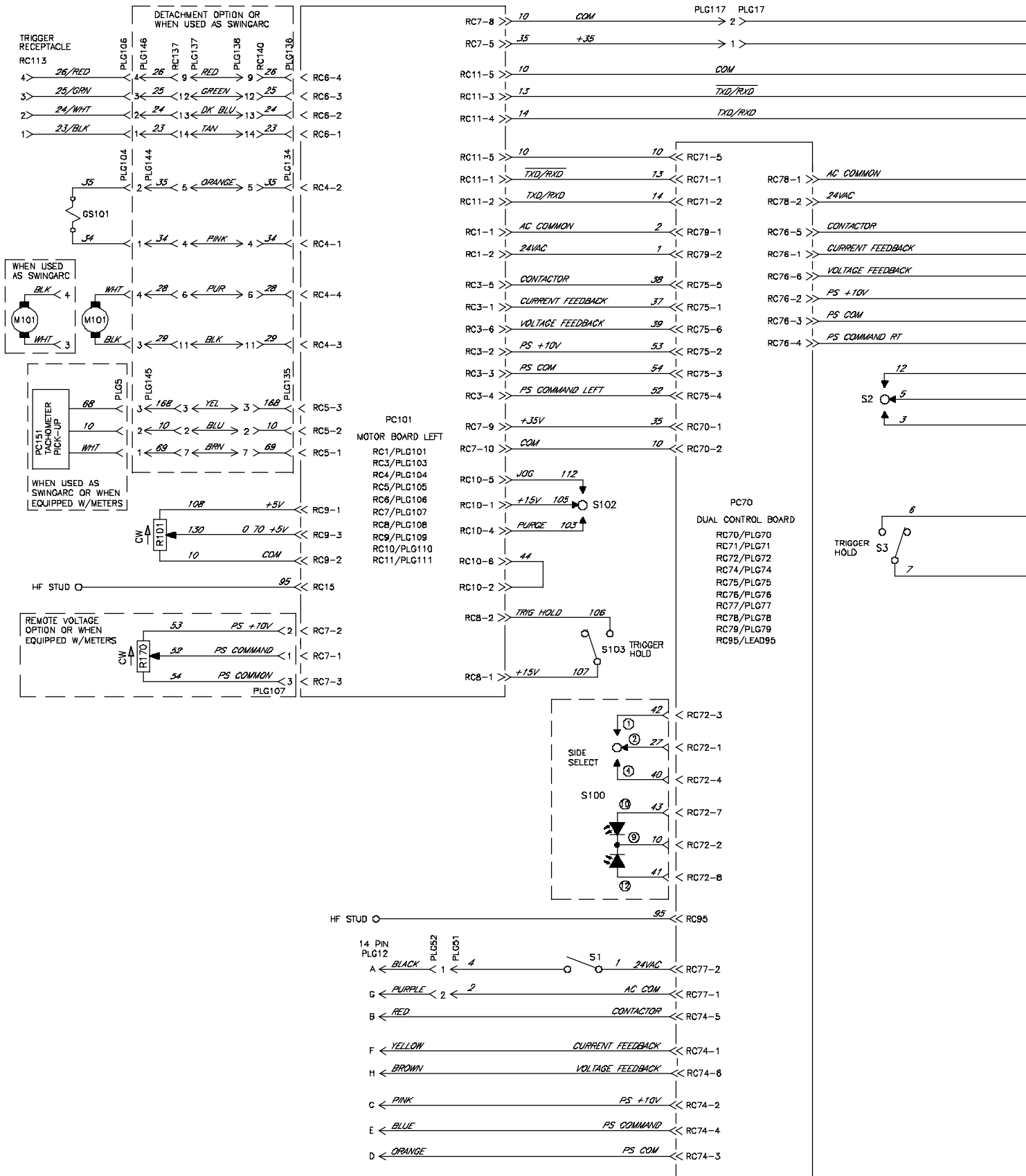
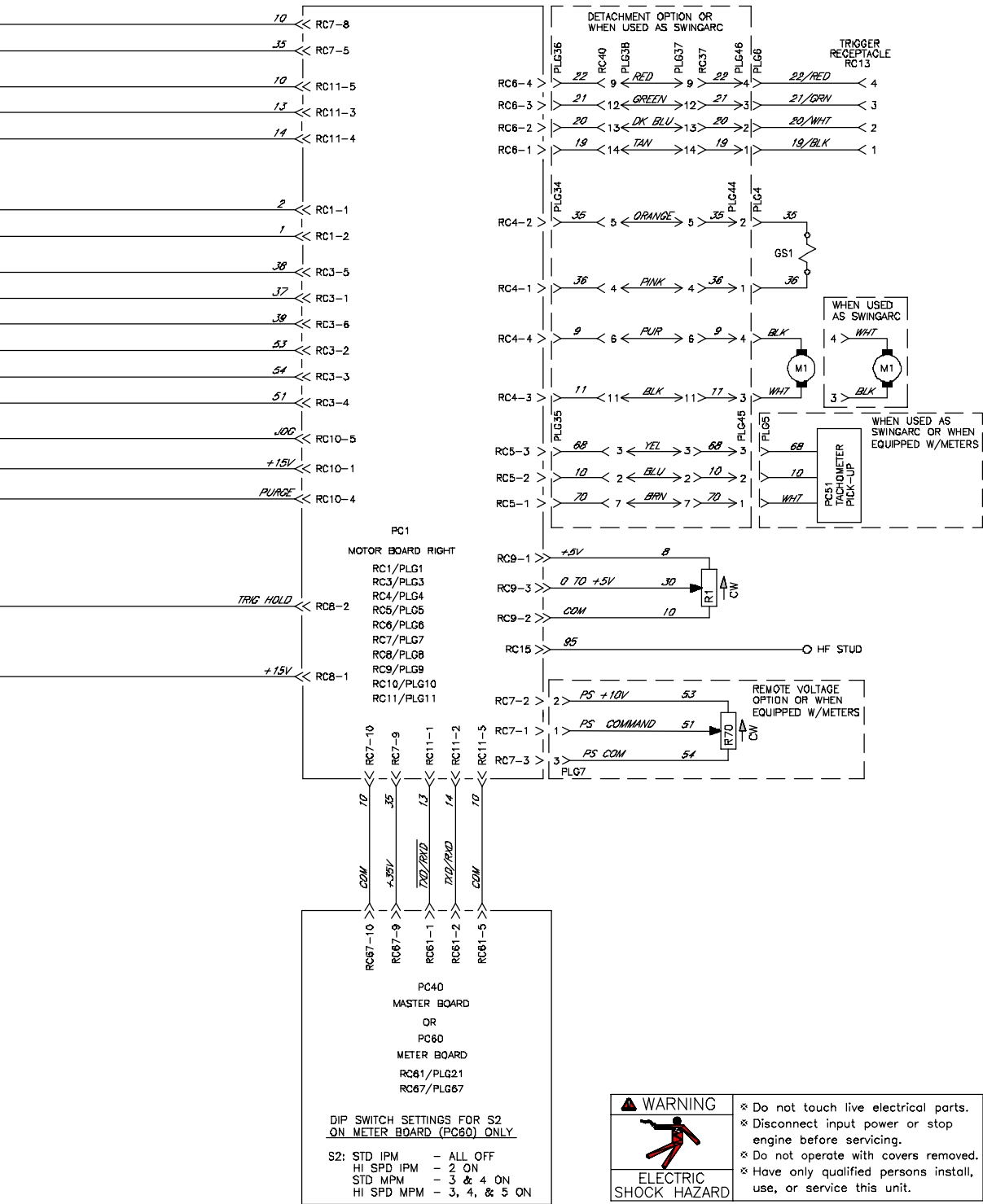



Figure 7-1. Circuit Diagram



 WARNING ELECTRIC SHOCK HAZARD	<ul style="list-style-type: none"> ⊗ Do not touch live electrical parts. ⊗ Disconnect input power or stop engine before servicing. ⊗ Do not operate with covers removed. ⊗ Have only qualified persons install, use, or service this unit.
--	--

SECTION 8 – PARTS LIST

 Hardware is common and not available unless listed.

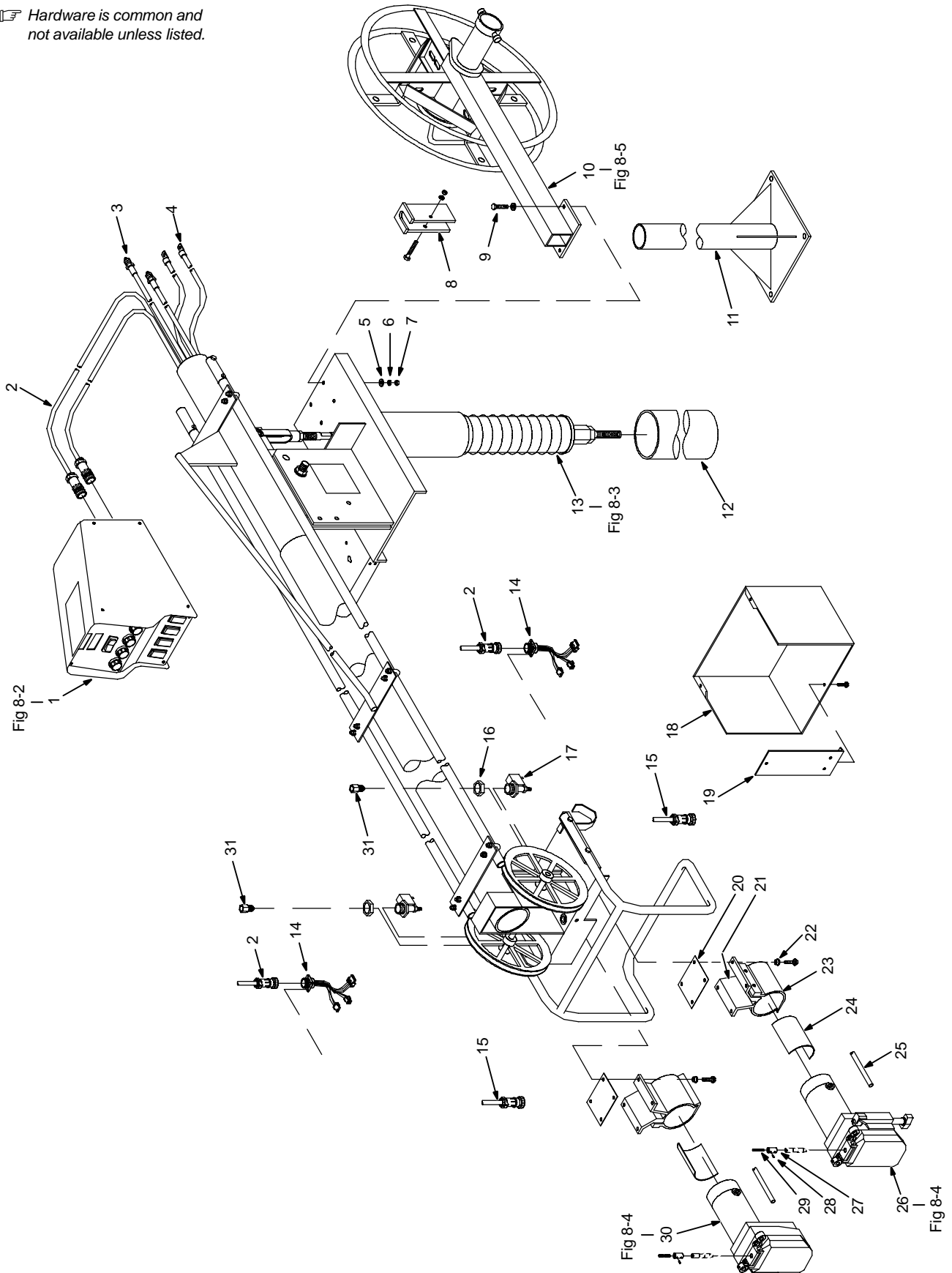

Figure 8-1. Main Assembly

803 189-C

Item No.	Dia. Mkgs.	Part No.	Description	Quantity	
				Model 12	Model 16
Figure 8-1. Main Assembly					
1		See Note	Control Box, (Fig 8-2)	1	1
2		201 319	Cable, Interconnecting (consisting of)	2	0
2		201 320	Cable, Interconnecting (consisting of)	0	2
	PLG37,38,137,138	047 636	Connector & Pins	2	2
		079 739	Connector, Circ Clamp Str Rlf Sz 17-20 Amp 206322-2	2	2
		163 520	Cable, Port No. 18/14 8/C (order by ft)	17Ft	21Ft
3		139 600	Hose, Gas	2	0
3		139 599	Hose, Gas	0	2
4		600 324	Cable, Weld Cop Strd No. 4/0 (order by ft)	26Ft	30Ft
5		602 243	Washer, Flat Stl Std .375	8	8
6		602 213	Washer, Lock Stl Split .375	4	4
7		601 872	Nut, Stl Hex Full .375-16	4	4
8		080 947	Bracket, Spring Retaining	1	0
8		151 626	Bracket, Spring Retaining	0	1
9		132 053	Screw, Cap Stl Hexhd .375-16 X 1.500 Lg	4	4
10		Fig 8-7	Support, Hub & Reel	1	1
11		◆149 838	Pipe Post, 4ft W/Base Or	1	0
11		◆149 839	Pipe Post, 6ft W/Base	1	0
11		◆078 264	Pipe Post, 4ft W/Base Or	0	1
11		◆079 216	Pipe Post, 6ft W/Base	0	1
12		◆075 078	Pipe Post, 4ft W/O Base Or	1	1
12		◆079 217	Pipe Post, 6ft W/O Base	1	1
13		Fig 8-5	Boom Assembly	1	1
14	RC37,137	047 637	Connector & Sockets (consisting of)	2	2
	PLG45,145	131 203	Housing Plug + Pins, (service kit)	2	2
	PLG44,144	167 640	Housing Plug Pins + Skts (service kit)	2	2
	PLG46,146	115 090	Housing Plug + Pins, (service kit)	2	2
15		203 314	Cable, Trigger 20 In Boom/Detach (consisting of)	2	2
		115 094	Housing Plug+Skts,(service kit)	2	2
		080 328	Rcpt W/Skts,Free Hanging	2	2
		079 531	Conn,Circ Cpc Clamp Str Rlf Size 11 .453od	2	2
		604 571	Cable,Port No 18 4/C Type sjo nprn jkt re		2Ft
16		605 227	Nut, Nyl Hex Jam .750npst	2	2
17	GS1,101	219 062	Valve, Gas W/Fittings 34VDC	2	2
	PLG4,104	136 810	Housing Plug + Skts (service kit)	2	2
18		139 813	Cover, Protector Motor	1	1
19		139 816	Panel, Encl Cover	1	1
20		159 647	Insulator, Motor Clamp	2	2
21		159 646	Clamp, Motor Base	2	2
22		159 360	Insulator, Screw Machine	8	8
23		156 243	Clamp, Motor Top	2	2
24		145 639	Strip, Buna N Compressed Sheet .062 X 4.000sq	2	2
25		134 834	Hose, Sae .187 Id X .410 Od (order by ft)	3Ft	3Ft
26		208 944	Drive Assy,Wire Rh Vertical 4 Roll W/Clamp&tach (Fig 8-4)	1	1
26		◆208 945	Drive Assy,Wire Rh Vert 4 Roll Hi-speed W/Cl&tach (Fig 8-4)	1	1
27		157 295	Guide, Monocoil	2	2
28		604 612	Screw, Set Stl Sch 8-32 X .125 Cup Point	4	4
29		082 050	Liner, Monocoil Inlet Wire	2	2
30		201 776	Drive Assy,Wire L Vertical 4 Roll W/Clamp&tach (Fig 8-4)	1	1
30		◆201 777	Drive Assy,Wire L Vert 4 Roll Hi-speed W/Cl&tach (Fig 8-4)	1	1
		149 322	Clamp, Hose .405-.485clp	4	4
31		211 989	Fitting, W/Screen	2	2

Note: When ordering Control Box contact factory service department for proper number.

To maintain the factory original performance of your equipment, use only Manufacturer's Suggested Replacement Parts. Model and serial number required when ordering parts from your local distributor.

Hardware is common and not available unless listed.

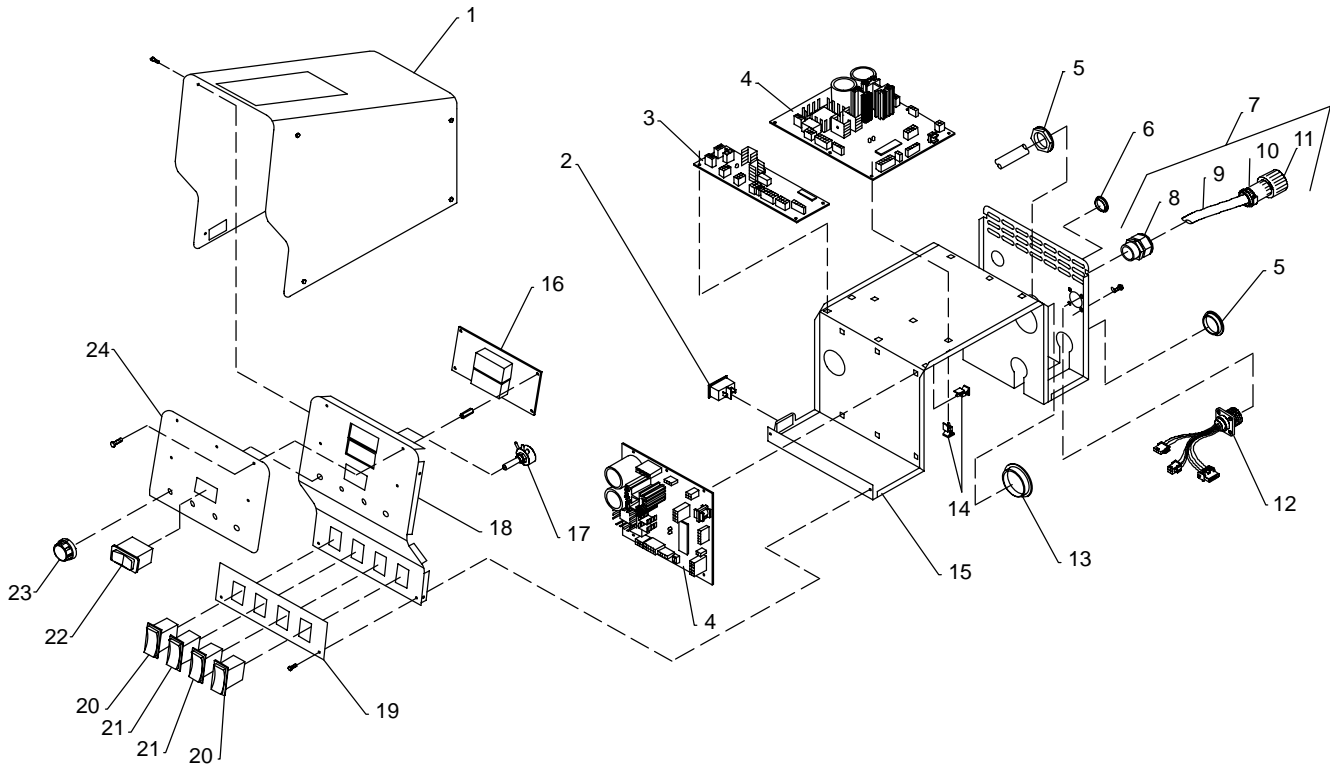

803 190

Figure 8-2. Control Box

Item No.	Dia. Mkgs.	Part No.	Description	Quantity	
				Model	
				D-74S	D-74D

Figure 8-2. Control Box (Figure 8-1 Item 1)

...	1	204 722	.. Wrapper, feeder	1	1
...		134 464	.. Label,Warning General Precautionary Static&Wire Feed	1	1
...	2	S1 111 997	.. Switch, Rocker Spst 10A 250vac On-Off Visi Red Rock	1	1
...	3	PC70 220 903	.. Circuit Card Assy, Dual W/Program	1	1
...	4	PC1,101 217 898	.. Circuit Card Assy, Motor Control W/Program	2	2
...	5	030 170	.. Bushing,Snap-in Nyl .750 Id X 1.000 Mtg Hole	1	1
...	6	047 838	.. Blank,Snap-in Nyl 1.000 Mtg Hole Black	2	2
...	6	000 527	.. Blank, Snap-in Nyl .875 Mtg Hole Black	1	1
...	7	201 228	.. Cable, Power 16.5ft 8/c 2-14ga 6-18ga (consisting of)	1	1
...	8	139 041	.. Strain Relief	1	1
...	9	163 519	.. Cable, Port	16.5	Ft
...	10	079 739	.. Conn, circ cpc clamp str rlf	1	1
...	11	PLG12 141 162	.. Housing Plug+Pins, (service kit)	1	1
...		PLG52 174 823	.. Housing Plug Pins+Skts, (service kit)	1	1
...		PLG74 115 093	.. Housing Plug+Skts, (service kit)	1	1
...	12	RC40,140 047 637	.. Housing Rcpt+Skts,(service kit)	2	2
...		PLG34,134 136 810	.. Housing Plug+Skts, (service kit)	2	2
...		PLG35,135 131 204	.. Housing Plug+Skts, (service kit)	2	2
...		PLG36,136 115 094	.. Housing Plug+Skts, (service kit)	2	2
...	13	010 494	.. Bushing, Snap-in Nyl 1.375 Id X 1.750 Mtg Hole	2	2
...	14	134 201	.. Stand-off Support, Pc Card .312/.375w/Post&lock .43	17	17
...	15	204 721	.. Enclosure, Control	1	1
...	16	PC60 220 801	.. Circuit Card Assy, Meter W/Program	0	1
...	16	PC40 220 797	.. Circuit Card Assy, Master W/Program D-74	1	0

Item No.	Dia. Mkgs.	Part No.	Description	Quantity	
				Model	
				D-74S	D-74D

Figure 8-2. Control Box (Continued)

... 17 ...	R1,101	... 073 562	.. Pot,Cp Std Slot 1t 2. W 10k Linear	2	0
... 17	R1,101,70,170	.. 603 856	.. Pot,Ww Sltd Sft 10/T 2 W 10k Ohm	0	4
... 18		... 204 723	.. Panel, Front	1	1
... 19		... 204 724	.. Nameplate, Miller Lower	1	1
... 20	S2,102	... 200 295	.. Switch, rocker spdt 15A 12V (on)-off-(on)	2	2
... 21	S3, S103	... 201 642	.. Switch, rocker spdt 15A 12V (on)-none-(on)	2	2
... 22	S100	... 201 641	.. Switch, rocker spdt 15A 12V (on)-off-(on) W/leds	1	1
... 23		... 193 919	.. Knob, pointer 1.250 dia x .250 id w/two set screws	2	4
... 24		... 206 513	.. Nameplate, Miller D-74S Upper	1	0
... 24		... 206 511	.. Nameplate, Miller D-74D Upper	0	1

+When ordering a component originally displaying a precautionary label, the label should also be ordered.

To maintain the factory original performance of your equipment, use only Manufacturer's Suggested Replacement Parts. Model and serial number required when ordering parts from your local distributor.

	Dia. Mkgs.	Part No.	Description	Quantity
--	------------	----------	-------------	----------

Harness Connectors/Receptacles

.....	PLG6,106	... 115 094	... Housing Plug+Skts, (service kit)	1
.....	PLG4,104	... 136 810	... Housing Plug+Skts, (service kit)	1
.....	PLG72	... 115 092	... Housing Plug+Skts, (service kit)	1
.....	PLG9,109	... 201 665	... Housing Plug+Skts, (service kit)	1
.....	PLG11, 21,71,111	.. 131 055	... Housing Rcpt+Skts, (service kit)	1
.....	PLG7,67,107	... 115 091	... Housing Plug+Skts, (service kit)	1
.....	PLG17,70	... 158 719	... Housing Plug+Skts, (service kit)	1
.....	PLG117	... 165 404	... Housing Rcpt+Skts, (service kit)	1
.....	PLG1,77,78,79,101	.. 202 592	... Housing Plug+Skts, (service kit)	1
.....	PLG3,75,76,103	.. 115 093	... Housing Plug+Skts, (service kit)	1
.....	PLG51	... 174 824	... Housing Plug Pins+Skts, (service kit)	1
.....	PLG8,108	... 131 054	... Housing Rcpt+Skts, (service kit)	1
.....	PLG10,110	... 130 203	... Housing Plug+Skts, (service kit)	1

 Hardware is common and not available unless listed.

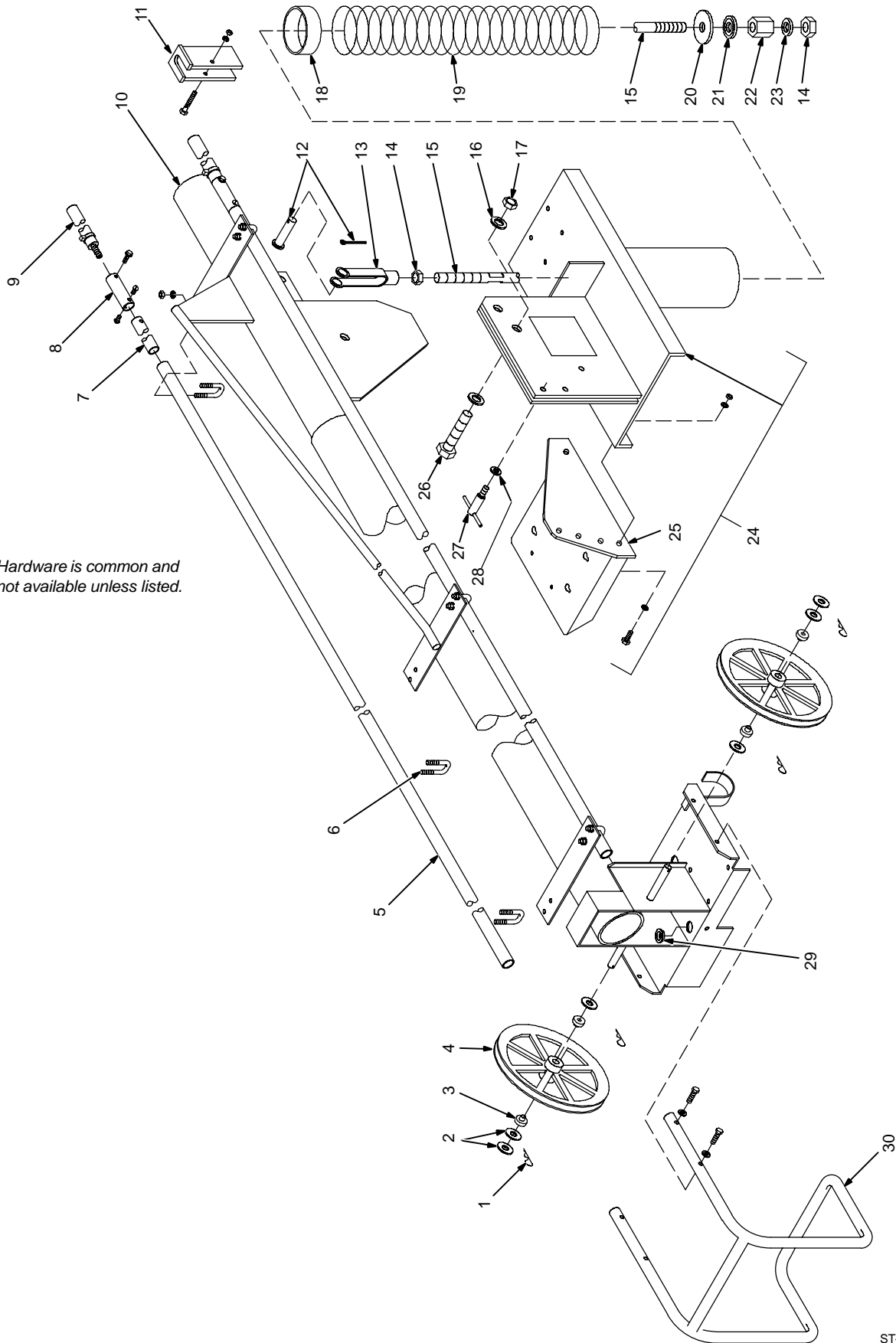

Figure 8-3. Boom Assembly

ST-142 306-H

Item No.	Part No.	Description	Quantity	
			12	16

Figure 8-3. Boom Assembly (Fig 8-1 Item 14)

1	010 313	Pin, Cotter Hair .072 X 1.437	4	4
2	010 910	Washer, Flat Stl Sae .375	6	6
3	079 622	Washer, Shld .381 Id X .750 Od	2	2
4	079 621	Pulley, V Sgl Grv 7.750dia X 8.000p X .625 Bore	2	2
5	079 667	Pipe, Plstc .500 X 133.750	2	0
5	080 812	Pipe, Plstc .500 X 181.750	0	2
6	079 632	Bolt, U Stl .250-20 X .875 Wide X 1.375 Deep	8	10
7	079 665	Guide, Wire	2	0
7	080 811	Guide, Wire	0	2
8	079 664	Guide, Wire Inlet	2	2
9	139 633	Liner, Monocoil 3/32-1/8 Wire X 15.687	2	2
10	159 999	Boom, Dual	1	0
10	160 513	Boom, Dual	0	1
11	080 947	Bracket, Spring Retaining	1	0
11	151 626	Bracket, Spring Retaining	0	1
12	073 742	Pin, Clevis .750 Od X 2.156 Lg	1	1
13	073 741	Clevis, .812 Yoke 6.062 Lg .750-16thd	1	1
14	079 029	Nut, Stl Hex Full Fnsh .750-16	2	2
15	075 462	Shaft, Boom Counterbalance	1	1
16	602 250	Washer, Flat Stl Sae .750	2	2
17	079 020	Nut, Stl Hex Elastic Stop .750-16	1	1
18	155 335	Pipe, Blk 3.000 X .875	0	1
19	149 858	Spring, Cprsn 3.750 Od X .625 Wire X 36.000	1	0
19	151 625	Spring, Cprsn 3.750 Od X .640 Wire X 36.000	0	1
20	150 258	Retainer, Spring	1	1
21	024 605	Bearing, Ball Thr Sgl Row .750 X 1.625 X .625	1	1
22	075 101	Nut, Stl Hex Special .750-16 X 1.250	1	1
23	079 030	Washer, Lock Stl Ext Tooth .750	1	1
24	+174 754	Base, Swivel Boom (consisting of)	1	1
	080 157	Fitting, Grease 1/8npt	1	1
25	174 688	Bracket, Mtg Control Tilt	1	1
	142 804	Label, Swingarc Caution Heavy Spring	1	1
	134 327	Label, Warning General Precautionary	1	1
26	073 666	Bolt, Mach Stl Hexhd .750-16 X 2.750	1	1
27	047 224	Knob, T-bar .500-13thd	1	1
28	602 246	Washer, Flat Stl Std .500	1	1
29	010 493	Bushing, Snap-in Nyl .625 Id X .875mtg Hole	1	1
30	139 818	Guard, Motor Protector	1	1

+When ordering a component originally displaying a precautionary label, the label should also be ordered.

To maintain the factory original performance of your equipment, use only Manufacturer's Suggested Replacement Parts. Model and serial number required when ordering parts from your local distributor.

☐ Hardware is common and not available unless listed.

See Table 8-1 For Drive Roll & Wire Guide Kits

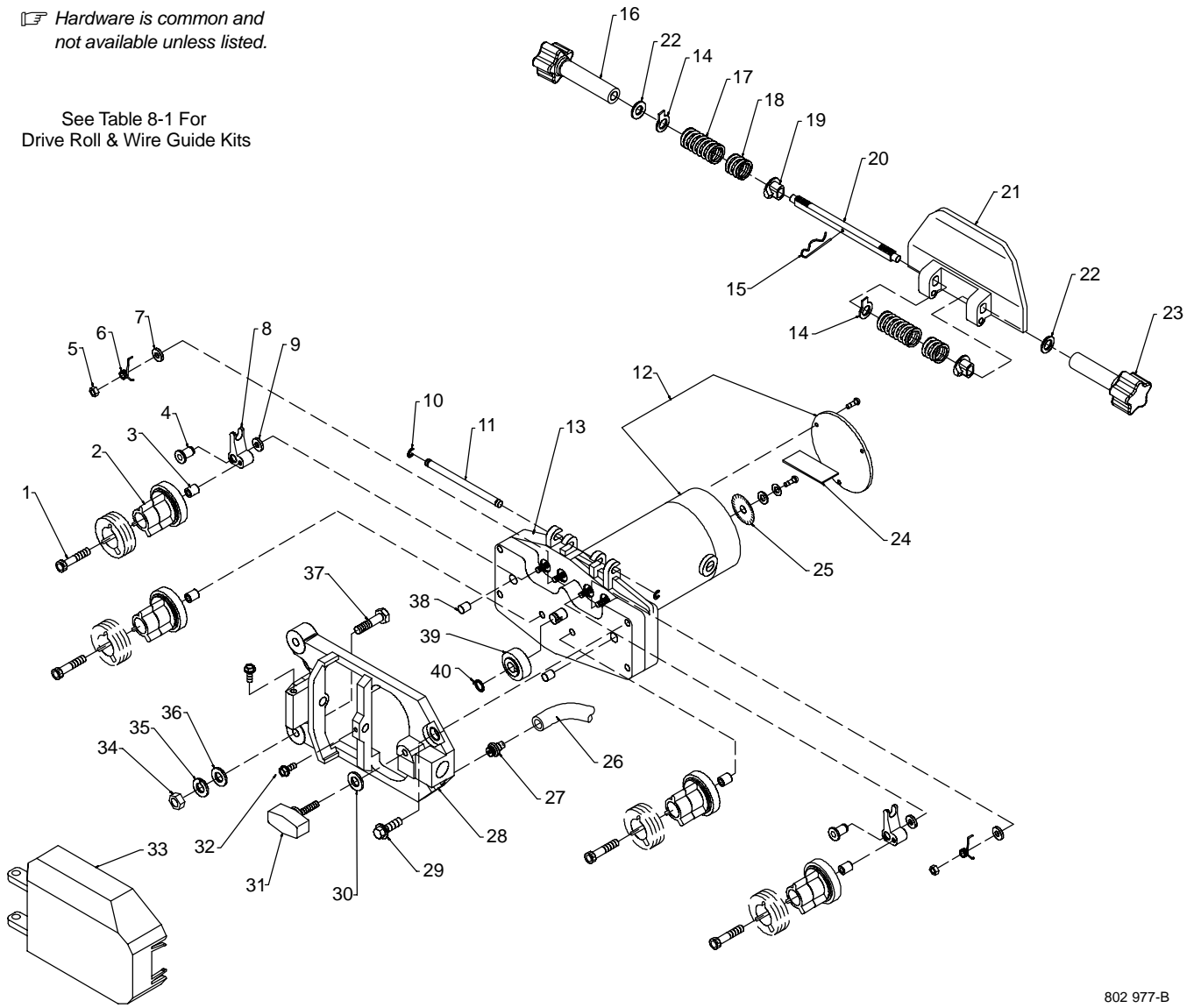

802 977-B

Figure 8-4. Drive Assembly, Wire

Item No.	Dia. Mkgs.	Part No.	Description	Quantity	
				Model	DS-74S DS-74D

Figure 8-4. Drive Assembly, Wire (Figure 8-1 Item 26)

...	1	010 668	.. Screw, Cap Stl Sch .250-20 X 1.500	4	4
...	2	172 075	.. Carrier, Drive Roll W/Components 24 Pitch	4	4
...	3	149 962	.. Spacer, Carrier Drive Roll	4	4
...	4	149 486	.. Pin, Rotation Arm Rocker	2	2
...	5	163 282	.. Nut, .250-28 Stl	2	2
...	6	165 798	.. Spring, Pressure Arm Retaining	2	2
...	7	165 799	.. Washer, Flat .257 Id Stl	2	2
...	8	132 750	.. Arm, Pressure	2	2
...	9	150 520	.. Spacer, Rotation Pin	2	2
...	10	133 493	.. Ring, Retaining Ext .250 Shaft X .025thk	2	2
...	11	133 350	.. Pin, Hinge	1	1
...	12	M1,101 201 230	.. Motor, Gear 1/8hp 24vdc Standard Speed	1	1
...	12	M1,101 201 231	.. Motor, Gear 1/8hp 24vdc High Speed	0	1
...		153 491	... Kit, Brush Replacement (consisting of)	1	1
...		153 492	... Cap, Brush	2	2
...		*153 493	... Brush, Carbon	2	2

Item No.	Dia. Mkgs.	Part No.	Description	Quantity	
				Model DS-12	DS-16

Figure 8-4. Drive Assembly, Wire (continued)

		184 136	Kit, Brush Holder	1	1
13		155 098	Kit, Cover Motor Gearbox (consisting of)	1	1
		153 550	Cover, Motor Gearbox (consisting of)	1	1
		155 099	Gasket, Cover	1	1
		155 100	Screw, Cover	5	5
		154 031	Spacer, Locating	2	2
		133 493	Ring, Rtnng Ext .250 Shaft Grv X .025Thk	1	1
		203 642	Pressure Arm, R & Vert L 4 Roll (consisting of)	1	1
		203 631	Pressure Arm, S/L & Vert S/R 4 Roll (consisting of)	1	1
14		203 641	Washer, Flat Indicator Spring Tension	2	2
15		182 415	Pin, Cotter Hair	1	1
16		203 640	Knob, W/Extension Short Pressure Arm	1	1
17		182 156	Spring, Cprsn	2	2
18		182 155	Spring	2	2
19		132 746	Bushing, Spring	2	2
20		203 633	Shaft, Spring	1	1
21		203 632	Carrier, Shaft	1	1
22		133 739	Washer, Flat Buna .375 Id X .625 Od X .062Thk	2	2
23		203 637	Knob, W/Extension Long Pressure Arm	1	1
24	PC51,151	201 225	Circuit Card, Digital Tach (consisting of)	1	1
	PLG5	131 204	Connector & Sockets	1	1
		604 311	Grommet, Rbr .250 Id X .375Mtg Hole	1	1
25		132 611	Optical Encoder Disc	1	1
		603 115	Weather Stripping, Adh .125 X .375	1	1
26		134 834	Hose, Sae .187 Id X .410 Od (order by ft)	2	Ft
27		149 959	Fitting, Brs Barbed M 3/16Tbg X .312-24	1	1
28		179 265	Adapter, Gun/Feeder Lh	1	1
28		179 264	Adapter, Gun/Feeder Rh	1	1
29		108 940	Screw, Cap Stl Hexwhd .250-20 X .750	4	4
30		604 538	Washer, Flat Stl Sae .312	1	1
31		151 437	Knob, Plstc T 1.125 Lg X .312-18 X 1.500 Bar	1	1
32		151 290	Screw, Hexwhd-Slt Stl Slffmg 10-32 X .500	2	2
33		179 277	Cover, Drive Roll (consisting of)	1	1
		196 956	Label, Warning Electric Shock And Pinch	1	1
34		601 872	Nut, Stl Hex Full .375-16	1	1
35		602 213	Washer, Lock Stl Split .375	1	1
36		602 243	Washer, Flat Stl .375	1	1
37		601 966	Screw, Cap Stl Hexhd .375-16 X 1.250	1	1
38		167 387	Spacer, Locating	2	2
39		168 825	Drive, Pinion 40t 24p .376 Bore	1	1
40		133 308	Ring, Retaining Ext .375 Shaft X .025Thk	1	1

*Recommended Spare Parts.

To maintain the factory original performance of your equipment, use only Manufacturer's Suggested Replacement Parts. Model and serial number required when ordering parts from your local distributor.

☞ Hardware is common and not available unless listed.

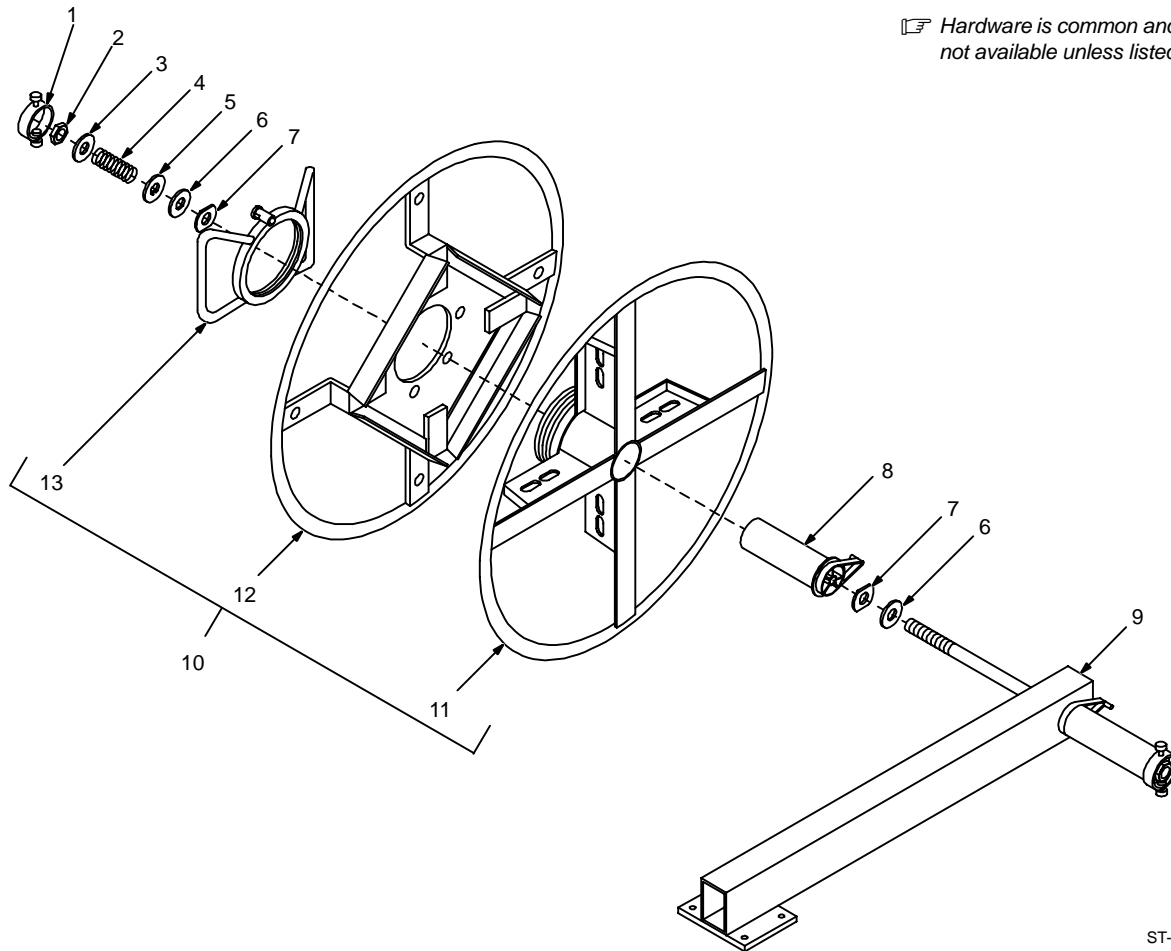

ST-081 760-C

Figure 8-5. Support, Hub & Reel

Item No.	Part No.	Description	Quantity
Figure 8-5. Support, Hub & Reel (Fig 8-1 Item 11)			
... 1	058 427	.. RING, retaining spool	2
... 2	136 684	.. NUT, stl slflkg hex reg .625-11 w/nyl insert	2
... 3	605 941	.. WASHER, flat stl .640 ID x 1.000 OD x 14ga thk	2
... 4	010 233	.. SPRING, cprsn .970 OD x .120 wire x 1.250	2
... 5	057 971	.. WASHER, flat stl keyed 1.500dia x .125thk	2
... 6	010 191	.. WASHER, fbr .656 ID x 1.500 OD x .125thk	4
... 7	058 628	.. WASHER, brake stl	4
... 8	058 428	.. HUB, spool	2
... 9	080 393	.. SUPPORT, reel	1
... 10	◆ 108 008	.. REEL, wire 60 lb (consisting of)	2
... 11	124 900	.. SUPPORT, reel spool	1
... 12	+168 104	.. RETAINER, spool support (consisting of)	1
	166 594	.. LABEL, caution falling wire reel can cause damage	1
... 13	168 103	.. NUT, spanner retaining	1

◆ OPTIONAL

+When ordering a component originally displaying a precautionary label, the label should also be ordered.

To maintain the factory original performance of your equipment, use only Manufacturer's Suggested Replacement Parts. Model and serial number required when ordering parts from your local distributor.

Table 8-1. Drive Roll and Wire Guide Kits

Wire Size		Inlet Guide	Intermediate Guide	V-GROOVE		U-GROOVE		VK-GROOVE		UC-GROOVE	
Fraction	Metric			4 Roll Kit	Drive Roll	4 Roll Kit	Drive Roll	4 Roll Kit	Drive Roll	4 Roll Kit	Drive Roll
.023-.025 in.	0.6 mm	150 993	149 518	151 024	087 130						
.030 in.	0.8 mm	150 993	149 518	151 025	053 695						
.035 in.	0.9 mm	150 993	149 518	151 026	053 700	151 036	072 000	151 052	132 958		
.040 in.	1.0 mm	150 993	149 518	161 189	053 696						
.045 in.	1.1/1.2 mm	150 994	149 519	151 027	053 697	151 037	053 701	151 053	132 957	151 070	083 489
.052 in.	1.3/1.4 mm	150 994	149 519	151 028	053 698	151 038	053 702	151 054	132 956	151 071	083 490
1/16 in. (.062 in.)	1.6 mm	150 995	149 520	151 029	053 699	151 039	053 706	151 055	132 955	151 072	053 708
.068-.072 in.	1.8 mm	150 995	149 520					151 056	132 959		
5/64 in. (.079 in.)	2.0 mm	150 995	149 520			151 040	053 704	151 057	132 960	151 073	053 710
3/32 in. (.094 in.)	2.4 mm	150 996	149 521			151 041	053 703	151 058	132 961	151 074	053 709
7/64 in. (.110 in.)	2.8 mm	150 996	149 521			151 042	053 705	151 059	132 962	151 075	053 711
1/8 in. (.125 in.)	3.2 mm	150 997	149 522			151 043	053 707	151 060	132 963	151 076	053 712

Each Kit Contains An Inlet Guide, Intermediate Guide, And 045 233 Antiwear Guide With 604 612 Setscrew 8-32 x .125, Along With 4 Drive Rolls.
2 Kits Required For Dual Models.

S-0549-D

TRUE BLUE® WARRANTY

Effective January 1, 2004

(Equipment with a serial number preface of "LE" or newer)

This limited warranty supersedes all previous Miller warranties and is exclusive with no other guarantees or warranties expressed or implied.

Warranty Questions?

Call
1-800-4-A-MILLER
for your local
Miller distributor.

Your distributor also gives
you ...

Service

You always get the fast,
reliable response you
need. Most replacement
parts can be in your
hands in 24 hours.

Support

Need fast answers to the
tough welding questions?
Contact your distributor.
The expertise of the
distributor and Miller is
there to help you, every
step of the way.

LIMITED WARRANTY – Subject to the terms and conditions below, Miller Electric Mfg. Co., Appleton, Wisconsin, warrants to its original retail purchaser that new Miller equipment sold after the effective date of this limited warranty is free of defects in material and workmanship at the time it is shipped by Miller. THIS WARRANTY IS EXPRESSLY IN LIEU OF ALL OTHER WARRANTIES, EXPRESS OR IMPLIED, INCLUDING THE WARRANTIES OF MERCHANTABILITY AND FITNESS.

Within the warranty periods listed below, Miller will repair or replace any warranted parts or components that fail due to such defects in material or workmanship. Miller must be notified in writing within thirty (30) days of such defect or failure, at which time Miller will provide instructions on the warranty claim procedures to be followed.

Miller shall honor warranty claims on warranted equipment listed below in the event of such a failure within the warranty time periods. All warranty time periods start on the date that the equipment was delivered to the original retail purchaser, or one year after the equipment is sent to a North American distributor or eighteen months after the equipment is sent to an International distributor.

1. 5 Years Parts — 3 Years Labor
 - * Original main power rectifiers
 - * Inverters (input and output rectifiers only)
2. 3 Years — Parts and Labor
 - * Transformer/Rectifier Power Sources
 - * Plasma Arc Cutting Power Sources
 - * Semi-Automatic and Automatic Wire Feeders
 - * Inverter Power Supplies (Unless Otherwise Stated)
 - * Intelligig
 - * Maxstar 150
 - * Engine Driven Welding Generators
(NOTE: Engines are warranted separately by the engine manufacturer.)
3. 1 Year — Parts and Labor Unless Specified
 - * DS-2 Wire Feeder
 - * Motor Driven Guns (w/exception of Spoolmate Spoolguns)
 - * Process Controllers
 - * Positioners and Controllers
 - * Automatic Motion Devices
 - * RFCS Foot Controls
 - * Induction Heating Power Sources
 - * Water Coolant Systems
 - * Flowgauge and Flowmeter Regulators (No Labor)
 - * HF Units
 - * Grids
 - * Maxstar 85, 140
 - * Spot Welders
 - * Load Banks
 - * Arc Stud Power Sources & Arc Stud Guns
 - * Racks
 - * Running Gear/Trailers
 - * Plasma Cutting Torches (except APT & SAF Models)
 - * Field Options
(NOTE: Field options are covered under True Blue® for the remaining warranty period of the product they are installed in, or for a minimum of one year — whichever is greater.)
4. 6 Months — Batteries
5. 90 Days — Parts
 - * MIG Guns/TIG Torches

- * Induction Heating Coils and Blankets
- * APT & SAF Model Plasma Cutting Torches
- * Remote Controls
- * Accessory Kits
- * Replacement Parts (No labor)
- * Spoolmate Spoolguns
- * Canvas Covers

Miller's True Blue® Limited Warranty shall not apply to:

1. **Consumable components; such as contact tips, cutting nozzles, contactors, brushes, slip rings, relays or parts that fail due to normal wear. (Exception: brushes, slip rings, and relays are covered on Bobcat, Trailblazer, and Legend models.)**
2. Items furnished by Miller, but manufactured by others, such as engines or trade accessories. These items are covered by the manufacturer's warranty, if any.
3. Equipment that has been modified by any party other than Miller, or equipment that has been improperly installed, improperly operated or misused based upon industry standards, or equipment which has not had reasonable and necessary maintenance, or equipment which has been used for operation outside of the specifications for the equipment.

MILLER PRODUCTS ARE INTENDED FOR PURCHASE AND USE BY COMMERCIAL/INDUSTRIAL USERS AND PERSONS TRAINED AND EXPERIENCED IN THE USE AND MAINTENANCE OF WELDING EQUIPMENT.

In the event of a warranty claim covered by this warranty, the exclusive remedies shall be, at Miller's option: (1) repair; or (2) replacement; or, where authorized in writing by Miller in appropriate cases, (3) the reasonable cost of repair or replacement at an authorized Miller service station; or (4) payment of or credit for the purchase price (less reasonable depreciation based upon actual use) upon return of the goods at customer's risk and expense. Miller's option of repair or replacement will be F.O.B., Factory at Appleton, Wisconsin, or F.O.B. at a Miller authorized service facility as determined by Miller. Therefore no compensation or reimbursement for transportation costs of any kind will be allowed.

TO THE EXTENT PERMITTED BY LAW, THE REMEDIES PROVIDED HEREIN ARE THE SOLE AND EXCLUSIVE REMEDIES. IN NO EVENT SHALL MILLER BE LIABLE FOR DIRECT, INDIRECT, SPECIAL, INCIDENTAL OR CONSEQUENTIAL DAMAGES (INCLUDING LOSS OF PROFIT), WHETHER BASED ON CONTRACT, TORT OR ANY OTHER LEGAL THEORY.

ANY EXPRESS WARRANTY NOT PROVIDED HEREIN AND ANY IMPLIED WARRANTY, GUARANTY OR REPRESENTATION AS TO PERFORMANCE, AND ANY REMEDY FOR BREACH OF CONTRACT TORT OR ANY OTHER LEGAL THEORY WHICH, BUT FOR THIS PROVISION, MIGHT ARISE BY IMPLICATION, OPERATION OF LAW, CUSTOM OF TRADE OR COURSE OF DEALING, INCLUDING ANY IMPLIED WARRANTY OF MERCHANTABILITY OR FITNESS FOR PARTICULAR PURPOSE, WITH RESPECT TO ANY AND ALL EQUIPMENT FURNISHED BY MILLER IS EXCLUDED AND DISCLAIMED BY MILLER.

Some states in the U.S.A. do not allow limitations of how long an implied warranty lasts, or the exclusion of incidental, indirect, special or consequential damages, so the above limitation or exclusion may not apply to you. This warranty provides specific legal rights, and other rights may be available, but may vary from state to state.

In Canada, legislation in some provinces provides for certain additional warranties or remedies other than as stated herein, and to the extent that they may not be waived, the limitations and exclusions set out above may not apply. This Limited Warranty provides specific legal rights, and other rights may be available, but may vary from province to province.





Owner's Record

Please complete and retain with your personal records.

Model Name	Serial/Style Number
Purchase Date	(Date which equipment was delivered to original customer.)
Distributor	
Address	
City	
State	Zip



For Service

Call 1-800-4-A-Miller or see our website at www.MillerWelds.com to locate a DISTRIBUTOR or SERVICE AGENCY near you.

Always provide Model Name and Serial/Style Number.

Contact your Distributor for:

- Welding Supplies and Consumables
- Options and Accessories
- Personal Safety Equipment
- Service and Repair
- Replacement Parts
- Training (Schools, Videos, Books)
- Technical Manuals (Servicing Information and Parts)
- Circuit Diagrams
- Welding Process Handbooks

Contact the Delivering Carrier to:

- File a claim for loss or damage during shipment.
- For assistance in filing or settling claims, contact your distributor and/or equipment manufacturer's Transportation Department.

Miller Electric Mfg. Co.

An Illinois Tool Works Company
1635 West Spencer Street
Appleton, WI 54914 USA

International Headquarters—USA

USA Phone: 920-735-4505 Auto-Attended
USA & Canada FAX: 920-735-4134
International FAX: 920-735-4125

European Headquarters – United Kingdom

Phone: 44 (0) 1204-593493
FAX: 44 (0) 1204-598066

www.MillerWelds.com

